

AKD[®], AKD[®] BASIC, AKD[®] PDMM

Installation Manual



Edition: N, December 2013

Valid for AKD, AKD BASIC Hardware Revision D

Valid for AKD BASIC-I/O Hardware Revision DA

Valid for AKD PDMM Hardware Revision DB

Part Number 903-200003-00

Original Document



Keep all manuals as a product component during the life span of the product.
Pass all manuals to future users and owners of the product.

KOLLMORGEN[®]

Because Motion Matters™

Record of Document Revisions

Revision	Remarks
...	Table with lifecycle information of this document see "Record of document revisions" (→ p. 195)
L, 05/2013	Hiperface DSL Feedback new (from FW 1.9), fault tables updated, KCM module added
M, 09/2013	24A AKD-M added, fault tables update, outer dimensions updated
N, 12/2013	sercos [®] III option added, SFD3 feedback added, sincos frequency limit, automatic restart notes

Hardware Revision (HR)

AKD	AKD-M	AKD-T-IC	Firmware	WorkBench	KAS IDE	Remarks
A	-	-	from 1.3	from 1.3	-	AKD Start revision
C	-	-	from 1.5	from 1.5	-	STO certified, PROFINET RT released
D	DB	DA	from 1.6	from 1.6	from 2.5	Control board revision 9, AKD PDMM Start revision, AKD BASIC-IC Start revision

Trademarks

- AKD is a registered trademark of Kollmorgen Corporation
- EnDat is a registered trademark of Dr. Johannes Heidenhain GmbH
- EtherCAT is a registered trademark and patented technology, licensed by Beckhoff Automation GmbH
- Ethernet/IP is a registered trademark of ODVA, Inc.
- Ethernet/IP Communication Stack: copyright (c) 2009, Rockwell Automation
- sercos[®] is a registered trademark of sercos[®] international e.V.
- HIPERFACE is a registered trademark of Max Stegmann GmbH
- PROFINET is a registered trademark of PROFIBUS and PROFINET International (PI)
- SIMATIC is a registered trademark of SIEMENS AG
- Windows is a registered trademark of Microsoft Corporation

Current patents

- US Patent 5,162,798 (used in control card R/D)
- US Patent 5,646,496 (used in control card R/D and 1 Vp-p feedback interface)
- US Patent 6,118,241 (used in control card simple dynamic braking)
- US Patent 8,154,228 (Dynamic Braking For Electric Motors)
- US Patent 8,214,063 (Auto-tune of a Control System Based on Frequency Response)

Technical changes which improve the performance of the device may be made without prior notice!

Printed in the United States of America

This document is the intellectual property of Kollmorgen. All rights reserved. No part of this work may be reproduced in any form (by photocopying, microfilm or any other method) or stored, processed, copied or distributed by electronic means without the written permission of Kollmorgen.

1 Table of Contents

1	Table of Contents	3
2	General	9
2.1	About this Manual	10
2.2	Using the PDF Format	10
2.3	Notes for the printed edition (paper version)	10
2.4	Symbols Used	11
2.5	Abbreviations Used	12
2.6	Standards Used	13
3	Safety	14
3.1	You should pay attention to this	15
3.2	Use as Directed	17
3.3	Prohibited Use	17
3.4	Handling	18
3.4.1	Transport	18
3.4.2	Packaging	18
3.4.3	Storage	18
3.4.4	Maintenance and Cleaning	19
3.4.5	Uninstalling	19
3.4.6	Repair and Disposal	19
4	Approvals	20
4.1	Conformance with UL/cUL	21
4.1.1	UL Markings	21
4.2	CE Conformance	22
4.2.1	European Directives and Standards for the Machine Builder	23
4.2.2	EC Declaration of Conformity	24
4.3	Safe Torque Off (STO)	25
5	Package	26
5.1	Package Supplied	27
5.2	Nameplate	27
5.3	Part Number Scheme	28
6	Technical description and data	29
6.1	The AKD Family of Digital Drives	30
6.2	Ambient Conditions, Ventilation, and Mounting Position	32
6.3	Mechanical Data	32
6.4	Inputs/Outputs	33
6.5	Electrical Data AKD-xzzz06	34
6.6	Electrical Data AKD-xzzz07	35
6.7	Performance Data	36
6.8	Recommended Tightening Torques	36
6.9	Fusing	37
6.9.1	External power supply fusing	37
6.9.2	External 24 V supply fusing	37
6.9.3	External regen resistor fusing	37

6.10	Grounding System	37
6.11	Connectors	38
6.12	Cable and Wire Requirements	39
6.12.1	General	39
6.12.2	Cable cross sections and requirements	39
6.13	Dynamic Braking	40
6.13.1	Regen circuit	40
6.13.1.1	Functional description	40
6.13.1.2	Technical data for AKD-xzzz06	41
6.13.1.3	Technical data for AKD-xzzz07	42
6.14	Switch-On and Switch-Off Behavior	43
6.14.1	Switch-on behavior in standard operation	44
6.14.2	Switch-off behavior	45
6.14.2.1	Switch-off behavior using the DRV.DIS command	45
6.14.2.2	Switch-off behavior using a digital input (controlled stop)	46
6.14.2.3	Switch-off behavior using HW Enable input (uncontrolled stop)	46
6.14.2.4	Switch-off behavior in the event of a fault	47
6.15	Stop / Emergency Stop / Emergency Off	50
6.15.1	Stop	50
6.15.2	Emergency Stop	51
6.15.3	Emergency Off	51
6.16	Safe Torque Off (STO)	52
6.16.1	Safety characteristic data	52
6.16.2	Use as directed	52
6.16.3	Prohibited use	52
6.16.4	Safety instructions	53
6.16.5	Technical data and pinning	54
6.16.6	Enclosure, wiring	54
6.16.7	Functional description	54
6.16.7.1	Signal diagram (sequence)	55
6.16.7.2	Functional test	55
6.16.7.3	Control circuit (example)	56
6.16.7.4	Mains supply circuit (example)	57
6.17	Shock-hazard Protection	58
6.17.1	Leakage current	58
6.17.2	Residual current protective device (RCD)	58
6.17.3	Isolating transformers	58
7	Mechanical Installation	59
7.1	Important Notes	60
7.2	Guide to Mechanical Installation	60
7.3	Mechanical Drawings Standard Width	61
7.3.1	Control cabinet layout AKD-xzzz06, standard width	61
7.3.2	Control cabinet layout AKD-xzzz07, standard width	62
7.3.3	Dimensions AKD-xzzz06, standard width	63
7.3.4	Dimensions AKD-xzzz07, standard width	64
7.4	Mechanical Drawings Extended Width	65

7.4.1 Control cabinet layout, example with AKD-M00306	65
7.4.2 Control cabinet layout, example with AKD-M00307	66
7.4.3 Dimensions AKD-xzzz06, extended width	67
7.4.4 Dimensions AKD-xzzz07, extended width	68
8 Electrical Installation	69
8.1 Important Notes	70
8.2 Guide to electrical installation	71
8.3 Wiring	72
8.4 Components of a servosystem	73
8.5 Connection Overview AKD-B, AKD-P, AKD-T	75
8.5.1 Connector assignment AKD-x00306, AKD-x00606	75
8.5.2 Connector assignment AKD-x01206	75
8.5.3 Connector assignment AKD-x02406 and AKD-xzzz07	76
8.5.4 Connection diagram AKD-x00306, AKD-x00606	77
8.5.5 Connection diagram AKD-x01206	78
8.5.6 Connection diagram AKD-x02406 and AKD-xzzz07	79
8.6 Connection Overview AKD-M	80
8.6.1 Connector assignment AKD-M00306, AKD-M00606	80
8.6.2 Connector assignment AKD-M01206	80
8.6.3 Connector assignment AKD-M02406 and AKD-Mzzz07	81
8.6.4 Connection diagram AKD-M00306, AKD-M00606	82
8.6.5 Connection diagram AKD-M01206	83
8.6.6 Connection diagram AKD-M02406 and AKD-Mzzz07	84
8.7 EMI Noise Reduction	85
8.7.1 Recommendations for EMI noise reduction	85
8.7.2 Shielding with external shielding busbar	86
8.7.2.1 Shielding Concept	86
8.7.2.2 Shielding Busbar	87
8.7.3 Shielding connection to the drive	88
8.7.3.1 Grounding plates	88
8.7.3.2 Shield connection clamps	88
8.7.3.3 Motor connector X2 with shielding connection	88
8.8 Electrical Supply Connection	89
8.8.1 Connection to various mains supply networks AKD-xzzz06 (120V to 240V)	89
8.8.2 Connection to various mains supply networks AKD-xzzz07 (240V to 480V)	90
8.8.3 24 V auxiliary supply (X1)	91
8.8.4 Mains supply connection (X3, X4)	92
8.8.4.1 Three phase connection (all AKD types)	92
8.8.4.2 Single phase connection (AKD-x00306 to AKD-x01206 only)	93
8.9 DC Bus link (X3)	94
8.9.1 External regen resistor (X3)	95
8.9.2 Capacitor Modules (X3)	96
8.9.2.1 Technical Data	96
8.9.2.2 Example installation with KCM-S and KCM-E	97
8.9.2.3 Example installation with KCM-P and KCM-E	98
8.9.2.4 Discharging KCM modules	99

8.10 Motor Connection	100
8.10.1 Motor power (X2)	101
8.10.1.1 Cable length \leq 25 m	101
8.10.1.2 Cable length $>$ 25 m	101
8.10.2 Motor holding brake (X2)	102
8.11 Feedback Connection	103
8.11.1 Feedback connector (X10)	104
8.11.2 Resolver	105
8.11.3 SFD	106
8.11.4 SFD3	107
8.11.5 Hiperface DSL	108
8.11.6 Encoder with BiSS	109
8.11.6.1 BiSS (Mode B) analog	109
8.11.6.2 BiSS (Mode C) digital	110
8.11.7 Sine Encoder with EnDat 2.1	111
8.11.8 Encoder with EnDat 2.2	112
8.11.9 Sine Encoder with Hiperface	113
8.11.10 Sine Encoder	114
8.11.11 Incremental Encoder	115
8.11.12 Tamagawa Smart Abs Encoder	116
8.12 Electronic gearing, Master-slave operation	117
8.12.1 Technical characteristics and pinout	117
8.12.1.1 Connector X7 Input	117
8.12.1.2 Connector X9 Input	118
8.12.1.3 Connector X9 Output	118
8.12.2 Command encoder signal connection	119
8.12.2.1 Incremental encoder input 5 V (X9)	119
8.12.2.2 Incremental encoder input 24 V (X7)	119
8.12.2.3 Encoder with EnDat 2.2 input 5 V (X9)	120
8.12.3 Pulse / Direction signal connection	121
8.12.3.1 Pulse / Direction input 5 V (X9)	121
8.12.3.2 Pulse / Direction Input 5V (X7)	121
8.12.4 Up / Down signal connection	122
8.12.4.1 Up / Down input 5 V (X9)	122
8.12.4.2 Up / Down input 24 V (X7)	122
8.12.5 Emulated Encoder Output (EEO)	123
8.12.6 Master-Slave control	124
8.13 I/O Connection	125
8.13.1 I/O connectors X7 and X8 (all AKD variants)	125
8.13.2 I/O connectors X21, X22, X23 and X24 (AKD-T with I/O option card only)	126
8.13.3 I/O connectors X35 and X36 (AKD-M only)	128
8.13.4 Analog Input (X8, X24)	129
8.13.5 Analog Output (X8, X23)	130
8.13.6 Digital Inputs (X7/X8)	131
8.13.6.1 Digital Inputs 1 and 2	133
8.13.6.2 Digital Inputs 3 to 7	133

8.13.6.3 Digital Input 8 (ENABLE)	133
8.13.7 Digital Outputs (X7/X8)	134
8.13.7.1 Digital Outputs 1 and 2	134
8.13.7.2 FAULT relay contacts	135
8.13.8 Digital Inputs with I/O option (X21, X22)	136
8.13.9 Digital Outputs with I/O option (X23/X24)	138
8.13.9.1 Digital Outputs 21 to 24, 26 to 29	138
8.13.9.2 Digital Relay Outputs 25, 30	139
8.13.10 Digital Inputs (X35/X36) with AKD-M	140
8.13.11 Digital Outputs (X35/X36) with AKD-M	142
8.13.11.1 Digital Outputs 21 and 22	142
8.14 LED display	143
8.15 Rotary Switches (S1, S2, RS1)	144
8.15.1 Rotary switches S1 and S2 with AKD-B, -P, -T	144
8.15.2 Rotary switch RS1 with AKD-M	144
8.16 Pushbuttons (B1, B2, B3)	145
8.16.1 Pushbutton B1 with AKD-B, -P, -T	145
8.16.2 Pushbuttons B1, B2, B3 with AKD-M	146
8.17 SD Card Slot	147
8.17.1 SD Card Slot with I/O option card	147
8.17.2 SD Card Slot with AKD-M	148
8.18 Service Interface (X11, X32)	149
8.18.1 Pinout X11, X32	149
8.18.2 Service Bus Protocols X11, X32	149
8.18.3 Possible Network Configurations	149
8.18.4 Setting the IP Address AKD-B, AKD-P, AKD-T	150
8.18.5 Setting the IP Address AKD-M	152
8.18.6 Modbus TCP	153
8.19 CAN-Bus Interface (X12/X13)	153
8.19.1 CAN-Bus activation with AKD-CC models	154
8.19.2 Baudrate for CAN-Bus	155
8.19.3 Node Address for CAN-Bus	156
8.19.4 CAN-Bus Termination	156
8.19.5 CAN-Bus Cable	156
8.19.6 CAN-Bus Wiring	157
8.20 Motion Bus Interface (X5/X6/X11)	158
8.20.1 Pinout X5, X6, X11	158
8.20.2 Bus Protocols X5, X6, X11	158
8.20.3 EtherCAT	159
8.20.3.1 EtherCAT activation with AKD-CC models	159
8.20.4 SynqNet	160
8.20.5 PROFINET	160
8.20.6 Ethernet/IP	160
8.20.7 sercos® III	161
9 Setup	162
9.1 Important Notes	163

9.2 Setup AKD-B, AKD-P, AKD-T	164
9.2.1 Setup software WorkBench	164
9.2.2 Use as directed	164
9.2.3 Software description	165
9.2.4 Hardware requirements	165
9.2.5 Operating systems	165
9.2.6 Installation under Windows 2000/XP/VISTA/7	166
9.2.7 Initial Drive Test AKD-B, AKD-P, AKD-T	167
9.2.7.1 Unpacking, mounting, and wiring the AKD	167
9.2.7.2 Minimum wiring for drive test without load	167
9.2.7.3 Set IP address	168
9.2.7.4 Confirm connections	168
9.2.7.5 Install and start WorkBench	169
9.2.7.6 Set drive IP address in WorkBench	169
9.2.7.7 Enable the drive using the setup wizard	169
9.3 Setup AKD-M	170
9.3.1 Setup software KAS IDE	170
9.3.2 Use as directed	170
9.3.3 Software description	171
9.3.4 Hardware requirements	171
9.3.5 Operating systems	171
9.3.6 Installation under Windows XP/7	172
9.3.7 Initial Drive Test AKD-M	173
9.3.7.1 Unpacking, mounting, and wiring the AKD PDMM	173
9.3.7.2 Minimum wiring for drive test without load	173
9.3.7.3 Set IP address	174
9.3.7.4 Confirm connections	174
9.3.7.5 Install and start KAS IDE	175
9.3.7.6 Set drive IP address in KAS IDE	176
9.3.7.7 Starting new project	177
9.4 Fault and Warning Messages	180
9.4.1 Fault and warning messages AKD	180
9.4.2 Additional fault messages AKD-T	188
9.4.3 Additional error and alarm messages AKD-M	190
9.4.3.1 Errors	190
9.4.3.2 Alarms	192
9.5 Troubleshooting the AKD	194
10 Record of document revisions	195
11 Index	197

2 General

2.1 About this Manual	10
2.2 Using the PDF Format	10
2.3 Notes for the printed edition (paper version)	10
2.4 Symbols Used	11
2.5 Abbreviations Used	12
2.6 Standards Used	13

2.1 About this Manual

This manual, *AKD Installation Manual* ("Instructions Manual" according to EC Machinery Directive 2006/42/EC), describes the AKD series of digital drives drive and includes information needed to safely install an AKD. A digital version of this manual (pdf format) is available on the DVD included with your drive. Manual updates can be downloaded from the Kollmorgen website (www.kollmorgen.com).

Additional documents include the following:

- *User Guide*: describes how to use your drive in common applications. It also provides tips for maximizing your system performance with the AKD. The *User Guide* includes the *Parameter and Command Reference Guide* which provides documentation for the parameters and commands used to program the AKD.
- *CAN-BUS Communication*: describes how to use your drive in CANopen applications.
- *EtherCAT Communication*: describes how to use your drive in EtherCAT applications.
- *Ethernet/IP Communication*: describes how to use your drive in Ethernet/IP applications.
- *sercos[®] III Communication*: describes how to use your drive in sercos[®] applications.
- *PROFINET RT Communication*: describes how to use your drive in PROFINET RT applications.
- *SynqNet Communication*: describes how to use your drive in SynqNet applications.
- *Accessories Manual*. It provides documentation for accessories like cables and regen resistors used with AKD. Regional variants of this manual exist.

2.2 Using the PDF Format

This document includes several features for ease of navigation

Cross References	Table of contents and index include active cross references.
Table of contents and index	Lines are active cross references. Click on the line and the appropriate page is accessed.
Page/chapter numbers in the text	Page/chapter numbers with cross references are active links.

2.3 Notes for the printed edition (paper version)









A printed version of the manual is enclosed with each product. For environmental reasons, the document was reduced in size and printed on DIN A5.

NOTE











Should you experience difficulties reading the font size of the scaled-down printed version, you can print and use the PDF version in DIN A4 format 1:1. You can find the PDF version on the DVD accompanying the product and on the Kollmorgen website.

2.4 Symbols Used

Warning Symbols

Symbol	Indication
	Indicates a hazardous situation which, if not avoided, will result in death or serious injury.
	Indicates a hazardous situation which, if not avoided, could result in death or serious injury.
	Indicates a hazardous situation which, if not avoided, could result in minor or moderate injury.
	This is not a safety symbol. Indicates situations which, if not avoided, could result in property damage.
	This is not a safety symbol. This symbol indicates important notes.
	Warning of a danger (general). The type of danger is specified by the text next to the symbol.
	Warning of danger from electricity and its effects.
	Warning of hot surfaces
	Warning of suspended loads.

Drawing symbols

Symbol	Description	Symbol	Description
	Signal ground		Diode
	Chassis ground		Relay
	Protective earth		Relay switch off delayed
	Resistor		Normally open contact
	Fuse		Normally closed contact

2.5 Abbreviations Used

Abbreviation	Meaning
AGND	Analog ground
CE	Communauté Européenne
COM	Serial interface for a personal computer
DCOMx	Communication line for digital inputs (with x=7 or 8)
Disk	Magnetic storage (diskette, hard disk)
EEPROM	Electrically erasable programmable memory
EMC	Electromagnetic compatibility
F-SMA	Fiber optic cable connector according to IEC 60874-2
KAS	Kollmorgen Automation Suite
KAS IDE	Setup software (Kollmorgen Automation Suite Integrated Development Environment) used for AKD PDMM drives
LED	Light-emitting diode
LSB	Low significant byte (or bit)
MSB	Main significant byte (or bit)
NI	Zero pulse
PC	Personal computer
PE	Protective earth
PLC	Programmable logic control
PWM	Pulse-width modulation
RAM	Random access memory (volatile memory)
$R_{\text{Brake}}/R_{\text{B}}$	Regen resistor (also called a brake resistor)
RBext	External regen resistor
RBint	Internal regen resistor
RCD	Residual current device
RES	Resolver
ROD	Incremental encoder (A quad B)
S1	Continuous operation
STO	Safe torque off
VAC	Volts, alternating current
VDC	Volts, direct current

2.6 Standards Used

Standard	Content
ISO 4762	Hexagon socket head cap screws
ISO 11898	Road vehicles — Controller area network (CAN)
ISO 12100	Safety of machinery: Basic concepts, general principles for design
ISO 13849	Safety of machinery: Safety-related parts of control systems
IEC 60085	Electrical insulation - Thermal evaluation and designation Maintenance
IEC 60204	Safety of Machinery: Electrical equipment of machinery
IEC 60364	Low-voltage electrical installations
IEC 60439	Low-Voltage Switchgear and Controlgear Assemblies
IEC 60529	International protection rating (IP code)
IEC 60664	Insulation coordination for equipment within low-voltage systems
IEC 60721	Classification of environmental conditions
IEC 61000	Electromagnetic compatibility (EMC)
IEC 61131	Programmable controllers
IEC 61491	Electrical equipment of industrial machines – Serial data link for real-time communications between controls and drives.
IEC 61508	Functional safety of electrical/electronic/programmable electronic safety-related systems
IEC 61800	Adjustable speed electrical power drive systems
IEC 62061	Functional safety of electrical/electronic/programmable electronic safety-related systems
IEC 82079	Preparation of instructions for use - Structuring, content and presentation
ANSI Z535	Product safety (symbols, colors, information)
UL 840	UL Standard for Safety for Insulation Coordination Including Clearances and Creepage Distances for Electrical Equipment
UL 508C	UL Standard for Safety Power Conversion Equipment

ANSI - American National Standard Institute, Inc.
 IEC - International Electrotechnical Commission
 ISO - International Organization for Standardization
 UL - Underwriters Laboratories

3 Safety

3.1 You should pay attention to this	15
3.2 Use as Directed	17
3.3 Prohibited Use	17
3.4 Handling	18

3.1 You should pay attention to this

This section helps you to recognize and avoid dangers to people and objects.

Read the documentation!

Read the available documentation before installation and commissioning. Improper handling of the drive can cause harm to people or damage to property. The operator of systems using the AKD must require that all personnel who work with the drive read and understand the manual before using the drive.

Check Hardware Revision!

Check the Hardware Revision Number of the product (see product label). This number is the link between your product and the manual, it must match the Hardware Revision Number on the cover page of the manual.

Pay attention to the technical data!

Adhere to the technical data and the specifications on connection conditions (rating plate and documentation). If permissible voltage values or current values are exceeded, the drives can be damaged.

Perform a risk assessment!

The manufacturer of the machine must generate a risk assessment for the machine, and take appropriate measures to ensure that unforeseen movements cannot cause injury or damage to any person or property. Additional requirements on specialist staff may also result from the risk assessment.

Automatic Restart!



The drive might restart automatically after power on, depending on the parameter setting. Risk of death or serious injury for humans working in the machine.

If the parameter DRV.ENDEFAULT is set to 1, then place a warning sign to the machine (Warning: Automatic Restart at Power On) and ensure, that power on is not possible, while humans are in a dangerous zone of the machine.

Specialist staff required!

Only properly qualified personnel are permitted to perform such tasks as transport, assembly, setup and maintenance. Qualified specialist staff are persons who are familiar with the transport, installation, assembly, commissioning and operation of drives and who bring their relevant minimum qualifications to bear on their duties:

- Transport: only by personnel with knowledge of handling electrostatically sensitive components.
- Unpacking: only by electrically qualified personnel.
- Installation: only by electrically qualified personnel.
- Basic tests / Setup: only by qualified personnel with knowledge of electrical engineering and drive technology

The qualified personnel must know and observe ISO 12100 / IEC 60364 / IEC 60664 and national accident prevention regulations.

Observe electrostatically sensitive components!

The drives contain electrostatically sensitive components which may be damaged by incorrect handling. Electrostatically discharge your body before touching the drive. Avoid contact with highly insulating materials (artificial fabrics, plastic film etc.). Place the drive on a conductive surface.

**Hot surface!**

Drives may have hot surfaces during operation. The heat sink can reach temperatures above 80°C. Risk of minor burns! Measure the temperature, and wait until the heat sink has cooled down below 40 °C before touching it.

**Earthing!**

It is vital that you ensure that the drive is safely earthed to the PE (protective earth) busbar in the switch cabinet. Risk of electric shock. Without low-resistance earthing no personal protection can be guaranteed.

**High voltages!**

The equipment produces high electric voltages up to 900V. Do not open or touch the equipment during operation. Keep all covers and cabinet doors closed. During operation, drives may have uncovered live sections, according to their level of enclosure protection. Wait at least seven minutes after disconnecting the drive from the main supply power before touching potentially live sections of the equipment (such as contacts) or removing any connections.

Capacitors can have dangerous voltages present up to seven minutes after switching off the supply power. Always measure the voltage in the DC bus link and wait until the voltage is below 60 V before handling components.

Never undo any electrical connections to the drive while it is live. There is a danger of electrical arcing with damage to contacts and personal injury.

Reinforced Insulation

Thermal sensors, motor holding brakes and feedback systems built into the connected motor must have reinforced insulation (according to IEC61800-5-1) against system components with power voltage, according to the required application test voltage. All Kollmorgen components meet these requirements.

Never modify the drive!

It is not allowed to modify the drive without permission by the manufacturer. Opening the housing causes loss of warranty.

3.2 Use as Directed

Drives are components that are built into electrical plants or machines and can only be operated as integral components of these plants or machines. The manufacturer of the machine used with a drive must generate a risk assessment for the machine and take appropriate measures to ensure that unforeseen movements cannot cause personnel injury or property damage.

Cabinet and wiring

Drives must only be operated in a closed control cabinet suitable for the ambient conditions → p. 29. Ventilation or cooling may be necessary to keep the temperature within the cabinet below 40 °C.

Use only copper conductors for wiring. The conductor cross-sections can be derived from the standard IEC 60204 (alternatively for AWG cross-sections: NEC Table 310-16, 75 °C column).

Power supply

The drives can be supplied by 1 or 3 phase industrial supply networks.

Drives in the AKD series can be supplied as follows:

- AKD-xzzz06: 1 or 3 phase industrial supply networks (not more than 200 kA symmetrical rated current at 120 V and 240 V).
- AKD-xzzz07: 3 phase industrial supply networks (not more than 200 kA symmetrical rated current at 240 V, 400 V and 480 V).

Connection to other voltage types of supply networks is possible with an additional isolating transformer (→ p. 89).

Periodic overvoltages between phases (L1, L2, L3) and the housing of the drive must not exceed 1000 V peak. In accordance with IEC 61800, voltage spikes (< 50 µs) between phases must not exceed 1000 V. Voltage spikes (< 50 µs) between a phase and the housing must not exceed 2000 V.

EMC filter measures for AKD-xzzz06 must be implemented by the user.

Motor voltage rating

The AKD family of drives is exclusively intended for driving suitable synchronous servomotors with closed-loop control of torque, speed, and/or position. The rated voltage of the motors must be at least as high as the DC bus link voltage divided by $\sqrt{2}$ produced by the drive ($U_{nMotor} \geq U_{DC} / \sqrt{2}$).

Safe torque off

Review the section "Use as Directed" in the STO chapter (→ p. 52) before using this safety function (according to ISO 13849 category 3).

3.3 Prohibited Use

Other use than that described in chapter "Use as directed" is not intended and can lead to personnel injuries and equipment damage. The drive may not be used with a machine that does not comply with appropriate national directives or standards. The use of the drive in the following environments is also prohibited:

- potentially explosive areas
- environments with corrosive and/or electrically conductive acids, alkaline solutions, oils, vapors, dusts
- ships or offshore applications

3.4 Handling

3.4.1 Transport

Transport the AKD in accordance with IEC 61800-2 as follows:

- Transport only by qualified personnel in the manufacturer's original recyclable packaging. Avoid shocks while transporting.
- Store at or below maximum stacking height:
 - AKD-x0306 to 0606 models: 8 cartons, all other models: 6 cartons
- Transport only within specified temperature ranges: -25 to +70 °C, max. rate of change 20 K/hour, class 2K3.
- Transport only within specified humidity: max. 95% relative humidity, no condensation, class 2K3.

NOTICE

The drives contain electrostatically sensitive components that can be damaged by incorrect handling. Electrostatically discharge yourself before touching the drive. Avoid contact with highly insulating materials, such as artificial fabrics and plastic films. Place the drive on a conductive surface.

If the packaging is damaged, check the unit for visible damage. Inform the shipper and the manufacturer of any damage to the package or product.

3.4.2 Packaging

The AKD packaging consists of recyclable cardboard with inserts and a label on the outside of the box.

Model	Package Dimensions (mm) HxWxL	Total Weight AKD-B, -P, -T (kg)	Total Weight AKD-M (kg)
up to AKD-x00606	113 x 250 x 222	1.7	1.9
AKD-x01206	158 x 394 x 292	3.4	3.6
AKD-x02406	158 x 394 x 292	5	5.2
AKD-x00307 and AKD-x00607	158 x 394 x 292	4.3	4.5
AKD-x01207	158 x 394 x 292	4.3	4.5
AKD-x02407	158 x 394 x 292	6.7	6.9

3.4.3 Storage

Store the AKD in accordance with IEC 61800-2 as follows:

- Store only in the manufacturer's original recyclable packaging.
- Store at or below maximum stacking height:
 - AKD-x0306 to 0606 models: 8 cartons, all other models: 6 cartons
- Store only within specified temperature ranges: -25 to +55 °C, max. rate of change 20 K/hour, class 1K4.
- Storage only within specified humidity: 5 to 95% relative humidity, no condensation, class 1K3.
- Store in accordance with the following duration requirements:
 - Less than 1 year: without restriction.
 - More than 1 year: capacitors must be re-formed before setting up and operating the drive. To re-form the capacitors, remove all electrical connections and apply single-phase 120 VAC for about 30 minutes to the L1/L2 terminals.

3.4.4 Maintenance and Cleaning

The drive does not require maintenance. Opening the drive voids the warranty.

The inside of the unit can only be cleaned by the manufacturer. To clean the drive exterior:

- Casing: Clean with isopropanol or similar cleaning solution.
- Protective grill on fan: Clean with a dry brush.

NOTICE

Do not immerse or spray the drive.

3.4.5 Uninstalling

If a drive must be uninstalled (such as for replacement), remove the drive as follows:

1. Switch off the main switch of the switchgear cabinet and the fuses that supply the system.



WARNING

Contacts can still have dangerous voltage present up to seven minutes after switching off mains voltage. Risk of electrical shock! Wait at least seven minutes after disconnecting the drive from the main supply power before touching potentially live sections of the equipment (e.g. contacts) or undoing any connections. Always measure the voltage in the DC bus link and wait until the voltage is below 60 V before touching or handling the drive.

2. Remove the connectors. Disconnect the potential earth connection last.
3. Check temperature.



CAUTION

During operation, the heat sink of the drive may reach temperatures above 80 °C (176 °F). Risk of minor burns. Before touching the device, check the temperature and wait until it has cooled below 40 °C (104 °F).

4. Uninstall. Remove the drive and power supply from the conductive, grounded mounting plate in the cabinet.

3.4.6 Repair and Disposal

Only the manufacturer can repair the drive. Opening the device voids the warranty. Uninstall the drive as described in "Uninstalling" (→ p. 19)), then send the drive in the original packaging to the manufacturer (see table below).

In accordance with the WEEE-2002/96/EC-Guidelines and similar, the manufacturer accepts returns of old devices and accessories for professional disposal. Transport costs are the responsibility of the sender. Send the devices to the manufacturer addresses shown in the table below.

USA	Europe
Kollmorgen 201 West Rock Road Radford, VA 24141	KOLLMORGEN Europe GmbH Pempelfurtstr. 1 D-40880 Ratingen

4 Approvals

4.1 Conformance with UL/cUL	21
4.2 CE Conformance	22
4.3 Safe Torque Off (STO)	25

4.1 Conformance with UL/cUL

This drive is listed under UL (Underwriters Laboratories Inc.) file number **E141084** Vol.3 Sec.5.

USL, CNL – Power conversion equipment (NMMS, NMMS7) – Models AKD followed by B, P, S, T, M or F, followed by 003, 006, 012, and 024, followed by 06 or 07, followed by additional suffixes.

USL

Indicates Investigated to United States Standard for Power Conversion Equipment, UL 508C, Third Edition, Revised February 15, 2008.

CNL

Indicates investigation to Canadian Standard for Industrial Control Equipment, CAN/CSA - C22.2 No. 14-2005, Second Edition, Revised April 2008.

Note:

CNL = Canadian National Standards - Listed.

USL = United States Standards - Listed.

4.1.1 UL Markings

- Identification of the terminals on the controller are coded so they may be identified in the instructions. The instructions shall identify power connections for power supply, load, control, and ground.
- Integral solid state short circuit protection does not provide branch circuit protection. Branch circuit protection must be provided in accordance with the National Electrical Code and any additional local codes.
- This product is suitable for use on a circuit capable of delivering not more than 200,000 rms symmetrical amperes, 240 V (AKD-xzzz06) / 480 V (AKD-xzzz07) volts maximum, when protected by fuses.
- The following fuse types are recommended:

Model	Fuse class	Rating	Max. Fuse Rating
AKD-x00306	J	600 VAC, 200 kA	10 A
AKD-x00606	J	600 VAC, 200 kA	15 A
AKD-x01206	J	600 VAC, 200 kA	15 A
AKD-x02406	J	600 VAC, 200 kA	30 A
AKD-x00307	J	600 VAC, 200 kA	6 A
AKD-x00607	J	600 VAC, 200 kA	10 A
AKD-x01207	J	600 VAC, 200 kA	15 A
AKD-x02407	J	600 VAC, 200 kA	30 A

- These drives provide solid state motor overload protection at 125% of the rated FLA Current.
- These devices are intended to be used in a pollution degree 2 environment.
- Maximum surrounding air temperature of 40°C.
- Use minimum 75°C copper wire.
- These devices do not provide over temperature sensing.
- Use fuses only.

- The following table illustrates the torque requirements for the field wiring connectors:

Model	Mains Connector	Motor Phase Connector	24 VDC Input Connector
AKD-x00306	5-7 in-lbs	5-7 in-lbs	4 in-lbs
AKD-x00606	5-7 in-lbs	5-7 in-lbs	4 in-lbs
AKD-x01206	5-7 in-lbs	7 in-lbs	4 in-lbs
AKD-x02406	7 in-lbs	7 in-lbs	4 in-lbs
AKD-x00307	7 in-lbs	7 in-lbs	4 in-lbs
AKD-x00607	7 in-lbs	7 in-lbs	4 in-lbs
AKD-x01207	7 in-lbs	7 in-lbs	4 in-lbs
AKD-x02407	7 in-lbs	7 in-lbs	4 in-lbs

4.2 CE Conformance

Conformance with the EC EMC Directive 2004/108/EC and the Low Voltage Directive 2006/95/EC is mandatory for the supply of drives within the European Community.

The drives have been tested by an authorized testing laboratory in a defined configuration, using the system components that are described in this documentation. Any divergence from the configuration and installation described in this documentation means that the user will be responsible for carrying out new measurements to ensure conformance with regulatory requirements.

AKD-xzzz06

NOTICE

AKD-xzzz06 drives do not have integrated EMC filters. These drives can cause high-frequency interferences in non industrial environment and may require measures for interference suppression (such as additional external EMC filters).

With external EMC filters for noise emission the AKD-xzzz06 meet the noise immunity requirements of the second environmental category (industrial environment) to a product of the category C2 (motor cable < 10 m).

With a motor cable length of 10 m or longer and external EMC filters, the AKD-xzzz06 meet the requirement of category C3.

AKD-xzzz07

NOTE

AKD-xzzz07 drives have integrated EMC filters.

The AKD-xzzz07 meet the noise immunity requirements to the 2nd environmental category (industrial environment). For noise emission the AKD-xzzz07 meet the requirement to a product of the Category C2 (motor cable < 10 m).

With a motor cable length of 10 m or longer, the AKD-xzzz07 meet the requirement to the Category C3.

4.2.1 European Directives and Standards for the Machine Builder

Drives are components that are intended to be incorporated into electrical plant and machines for industrial use. When the drives are built into machines or plant, the drive must not be used until it has been established that the machine or equipment fulfills the requirements of the

- EC Machinery Directive (2006/42/EC)
- EC EMC Directive (2004/108/EC)
- EC Low Voltage Directive (2006/95/EC)

Standards to be applied for conformance with the EC Machinery Directive (2006/42/EC)

- IEC 60204-1 (Safety and Electrical Equipment in Machines)
- ISO 12100 (Safety of Machines)

NOTICE

The manufacturer of the machine must generate a risk assessment for the machine, and must implement appropriate measures to ensure that unforeseen movements cannot cause injury or damage to any person or property.

Standards to be applied for conformance with the EC Low Voltage Directive(2006/95/EC)

- IEC 60204-1 (Safety and Electrical Equipment in Machines)
- IEC 60439-1 (Low-voltage switchgear and controlgear assemblies)

Standards to be applied for conformance with the EC EMC Directive (2004/108/EC)

- IEC 61000-6-1/2 (Interference Immunity in Residential & Industrial Areas)
- IEC 61000-6-3/4 (Interference Generation in Residential & Industrial Areas)

The manufacturer of the machine/plant is responsible for ensuring that it meets the limits required by the EMC regulations. Advice on the correct installation for EMC (such as shielding, grounding, treatment of connectors and cable layout) is shown in this manual.

NOTE

The machine/plant manufacturer must check whether other standards or EC Directives must be applied to the machine/plant.

Kollmorgen only guarantees the conformance of the servosystem with the standards cited in this chapter if the components (motor, cables, chokes etc.) are those supplied by Kollmorgen.

4.2.2 EC Declaration of Conformity

EC Declaration of Conformity

KOLLMORGEN

Document No.: GL-11/29/14/13

We, the company

KOLLMORGEN Corp
201 Rock Road
Radford, VA 24141 USA

hereby in sole responsibility declare the conformity of the product series

Servo drive AKD (types AKD-x0030x ... AKD-x0240x)

with the following directives:

- EC Directive 2006/42/EG
Directive for machinery
Used harmonized standards
EN 61800-5-2 (2007)
EN ISO 13849-1 (2008)
EN ISO 13849-2 (2012)
- EC Directive 2004/108/EC
Electromagnetic compatibility
Used harmonized standard EN61800-3 (2004)
- EC Directive 2006/95/EC
Electrical devices for use in special voltage limits
Used harmonized standard EN61800-5-1 (2007)

Year of EC-Declaration 2009

Issued by: Engineering Manager
 Steven McClellan
 Radford, 02.04.2013



Legally valid signature

The above-mentioned company has the following technical documentation for examination:

- Proper operating instructions
- Setup Software
- Diagrams / software source codes (for EU authority only)
- Test certificates (for EU authority only)
- Other technical documentation (for EU authority only)

The special technical product documentation has been created.

Responsible person for documentation:

Lars Lindner, Kollmorgen Europe GmbH, Ratingen, Germany, Phone: +49(0)2102/9394-0

4.3 Safe Torque Off (STO)

An additional digital input (STO) releases the power output stage of the drive as long as a 24 V signal is applied to this input. If the STO input goes open-circuit, then power will no longer be supplied to the motor, and the drive will lose all torque and coast to a stop.

The STO safety implementation on the AKD is certified by the IFA (Institut für Arbeitsschutz der Deutschen Gesetzlichen Unfallversicherung). The safety circuit implementation for realizing the safety function "Safe Torque Off" in the drive is suited for SIL2 according to IEC 61508-2 and PLd, Cat.3 according to ISO 13849-1. The subsystems (AKD drives) are totally described for safety technics with the characteristic data :

Device	Operation Mode	ISO 13849-1	IEC 61508-2	PFH [1/h]	T _M [Years]	SFF [%]
STO	STO single channel	PL d, CAT 3	SIL 2	0	20	100

5 Package

5.1 Package Supplied	27
5.2 Nameplate	27
5.3 Part Number Scheme	28

5.1 Package Supplied

When a drive from the AKD series is ordered, the following items are included in the drive package:

- AKD
- Printed copy of *AKD Installation Manual* (EU only)
- Printed copy of *AKD Quick Start* (not in EU)
- Printed copy of fault and warning card (not in EU)
- DVD containing the setup software, WorkBench, and all product documentation in digital format.
- Mating connectors X1, X2, X3, X4 (if required), X7 and X8, X35 and X36 (if required)
- Grounding plate, with AKD voltage type 07, with voltage type 06 for EU only

NOTE

The mating SubD and RJ45 connectors are not included in the package.

Accessories Sold Separately

Accessories must be ordered separately if required; refer to your regional accessories manual:

- EMC filters for 24 V and mains supply voltage, categories C2 or C3
- External regen resistor
- Motor cable. Assembled motor cables are available for all regions.
- Feedback cable. Assembled feedback cables are available for all regions.
- Motor choke, for motor cables longer than 25 m
- CAN termination connector (with CAN drives only)
- Service cable to the network
- Power cable, control cables, and fieldbus cables (as cutoff lengths)

5.2 Nameplate

The nameplate depicted below is attached to the side of the drive, sample data entries are for a 12 A type.

KOLLMORGEN		Customer Support:	
201 W. Rock Road Radford, VA 24141		North America: +1 (540) 633-3400 Europe: +49 (0) 203-99790 Italy: +39 (0) 362-694260	
Model No:	AKD-B01207-NACN-0000		
Serial No:	R-0912-00001	HW Rev:	A
MAC Address:	00-00-00-00-00-00		
	INPUT	OUTPUT	
Voltage	480 Vac	0-480 Vac	
Frequency	50/60 Hz	0-600 Hz	
Phase	3 Ph	3 Ph	
FL Current	9.2 Arms	12 Arms	
Power @ 480 Vac	7.65 kVA		
Enclosure Protection Rating:	IP20		
Before use, refer to CD for installation and safety information.			
Assembled in USA	Patents Pending	www.kollmorgen.com	

CE

UL LISTED IND. CONT. EQ. 8F2

RoHS

5.3 Part Number Scheme

The part number is identical to the order code.

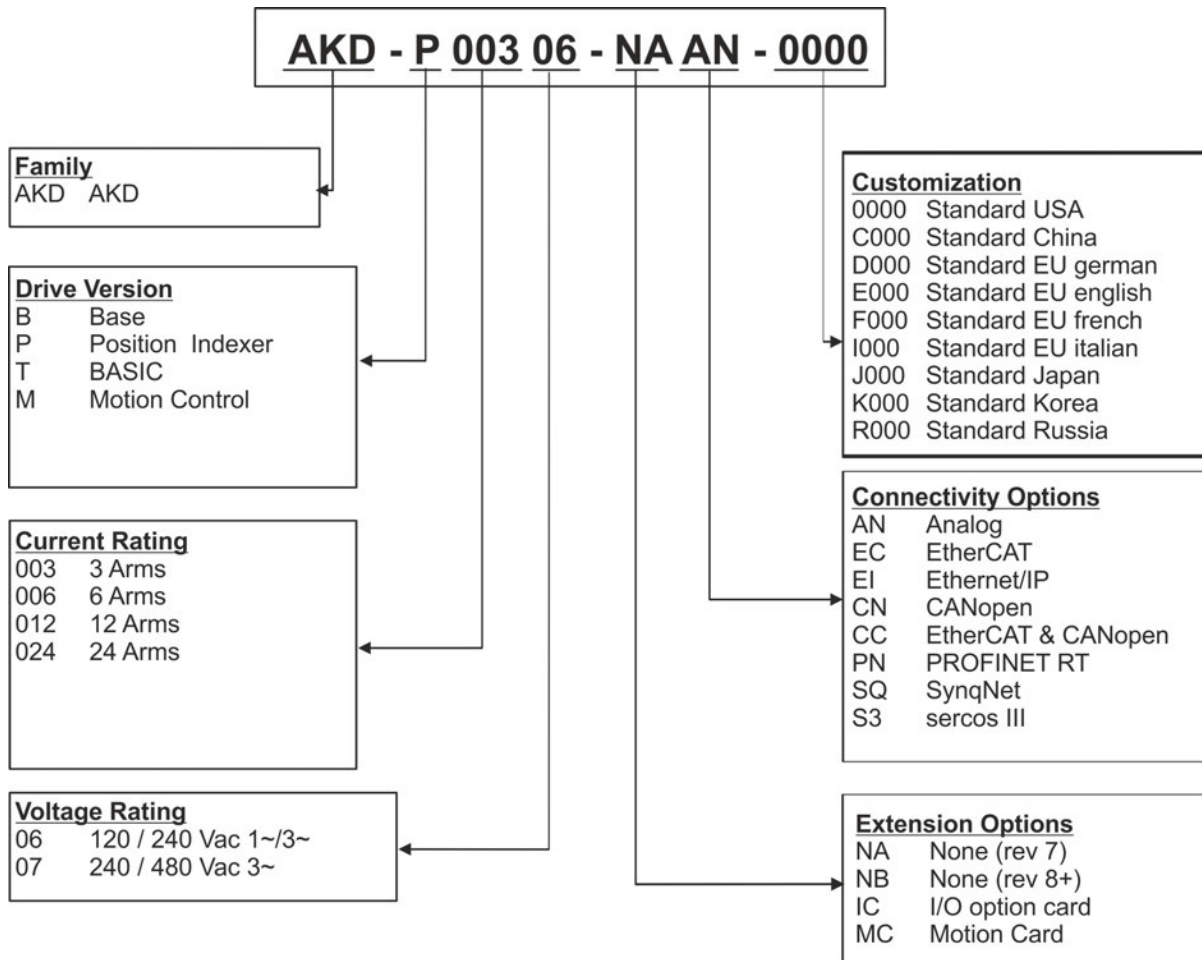

Customization: this code includes language version of printed material and customer specials.

Connectivity Options: The drive models with connectivity option CC are fitted with both the EtherCAT (X5 and X6) and CANopen (X12 and X13) fieldbus connectors. A software parameter (DRV.TYPE) allows you to select what features the drive supports; you cannot use EtherCAT and CANopen at the same time. PROFINET is possible with Position Indexer drives only (P version).

6 Technical description and data

6.1	The AKD Family of Digital Drives	30
6.2	Ambient Conditions, Ventilation, and Mounting Position	32
6.3	Mechanical Data	32
6.4	Inputs/Outputs	33
6.5	Electrical Data AKD-xzzz06	34
6.6	Electrical Data AKD-xzzz07	35
6.7	Performance Data	36
6.8	Recommended Tightening Torques	36
6.9	Fusing	37
6.10	Grounding System	37
6.11	Connectors	38
6.12	Cable and Wire Requirements	39
6.13	Dynamic Braking	40
6.14	Switch-On and Switch-Off Behavior	43
6.15	Stop / Emergency Stop / Emergency Off	50
6.16	Safe Torque Off (STO)	52
6.17	Shock-hazard Protection	58

6.1 The AKD Family of Digital Drives

Available AKD versions

Variant (short)	Description	Current	Housing	Connectivity
AKD-B***	Base drive is controlled by analog torque & velocity commands (electronic gearing).	3 to 24 A	Standard	Analog, Synq-Net
AKD-P**	Position Indexer drive adds the ability to command multiple motions, process I/O, make decisions, add time delays, modify drive process variables to the base drive.	3 to 24 A	Standard	Analog, CAN-open, EtherCAT, PROFINET RT, Ethernet/IP, sercos® III
AKD-M***-MC	Motion Controller PDMM/EtherCAT master drive. Includes all five IEC 61131 languages, PLC Open and Pipes Network. This drive is called AKD PDMM.	3 to 24 A	Extended width	EtherCAT
AKD-T***	Simple BASIC programmability added to the Base drive. This drive is called AKD BASIC.	3 to 24 A	Standard	Analog
AKD-T***-IC	AKD BASIC with I/O expansion.	3 to 24 A	Extended width	Analog, I/O expansion

Standard features

- Supply voltage range 120 V to 480 V $\pm 10\%$
- Several housing dimensions, depending on current and hardware options.
- Motion bus onboard, TCP/IP service channel onboard.
- SFD, Hiperface DSL, Tamagawa Smart Abs, Resolver, Comcoder, 1Vp-p Sin-Cos encoders, incremental encoders support onboard.
- Support for ENDAT 2.1 & 2.2, BiSS or HIPERFACE protocols onboard.
- Encoder emulation onboard and support for second feedback
- Safe Torque Off (STO) according to IEC 61508 SIL 2 onboard.
- Use with Synchronous servomotors, linear motors, and induction machines can be used.

Power section

- One or three phase supply, voltage range 120 to 480 V $\pm 10\%$, 50 to 400 Hz $\pm 5\%$ or DC. Connection to higher voltage mains only via isolating transformer, → p. 90. Single phase supply possible with output power derating.
- B6 bridge rectifier, integral soft-start circuit.
- Fusing to be provided by the user.
- DC bus link voltage range 170 to 680 VDC, can be connected in parallel.
- Output stage IGBT module with floating current measurement.
- Regen circuit with dynamic distribution of the generated power between several drives on the same DC bus link circuit.
- Internal regen resistor for all 240/480 VAC AKD-xzzz07 models (only 120/240 VAC 3 A and 6 A AKD-xzzz06 models lack internal regen resistors), external regen resistors if required.

Integrated safety

- Appropriate insulation/creepage distances and electrical isolation for safe electrical separation, per IEC 61800-5-1, between the power input/motor connections and the signal electronics.
- Soft-start, overvoltage detection, short-circuit protection, phase-failure monitoring.
- Temperature monitoring of the drive and motor.
- Motor overload protection: foldback mechanism
- SIL 2 safe torque off in accordance with IEC 61508, → p. 52.

Auxiliary supply voltage 24V DC

- From an external, safety approved 24 V \pm 10% power supply.

Operation and parameter setting

- Using the setup software WorkBench for setup via TCP/IP or KAS IDE for AKD PDMM setup.

Full digital control

- Digital current controller (670 ns)
- Adjustable digital velocity controller (62.5 μ s)
- Software option position controller (250 μ s)

Inputs/Outputs

- 1 programmable analog input → p. 129
- 1 programmable analog output → p. 130
- 7 programmable digital inputs → p. 131
- 2 programmable digital outputs → p. 134
- 1 Enable input → p. 131
- 1 STO input → p. 52
- additional digital inputs and outputs depending on variants (for example AKD PDMM)

Option Cards

Integrated option cards affect the device width.

- IC: additional digital inputs and outputs.
- MC: Motion Controller card with additional digital inputs and outputs. Extends the AKD to AKD PDMM type (part number scheme: AKD-M), a master drive for multiaxis, synchronized drive systems.

Connectivity

- Inputs/Outputs (→ p. 125)
- Encoder feedback output (→ p. 123)
- Service Interface (→ p. 149)
- CANopen (→ p. 153), optional
- Motion Bus interface (→ p. 158)
 - SynqNet (→ p. 160), optional
 - EtherCAT (→ p. 159), optional
 - PROFINET RT (→ p. 160), optional
 - Ethernet/IP (→ p. 160), optional
 - sercos[®] III (→ p. 161), optional

6.2 Ambient Conditions, Ventilation, and Mounting Position

Storage	→ p. 18
Transport	→ p. 18
Ambient temperature in operation	0 to +40 °C under rated conditions +40 to +55 °C with continuous current derating 4 % per Kelvin
Humidity in operation	Relative humidity 5 to 85%, no condensation, class 3K3
Site altitude	Up to 1000 meters above mean sea level without restriction 1,000 to 2,500 meters above mean sea level with power derating 1.5%/100 m
Pollution level	Pollution level 2 as per IEC 60664-1
Vibrations	Class 3M1 according to IEC 60721-3-3
Enclosure protection	IP 20 according to IEC 60529
Mounting position	Vertical, → p. 61
Ventilation	Built-in fan (except AKD-x00306 type)
NOTICE	The drive shuts down (fault F234, → p. 180, motor has no torque) in case of excessively high temperature in the control cabinet. Make sure sufficient forced ventilation is supplied within the control cabinet.

6.3 Mechanical Data

Mechanical data	Units	AKD -x00306	AKD -x00606	AKD -x01206	AKD -x02406
Weight (standard width)	kg	1.1		2	3.7
Weight (extended width)	kg	1.3		2.2	4
Height, without connectors	mm	168		196	248
Height, with connector	mm	200		225	280
Standard Width front/back	mm	54/59		72/78.4	96/100
Extended Width front/back	mm	84/89		91/96	96/100
Depth, without connectors	mm	156		187	228
Depth, with connectors	mm	185		< 215	<265

Mechanical data	Units	AKD -x00307	AKD -x00607	AKD -x01207	AKD -x02407
Weight (standard width)	kg		2.7		5.3
Weight (extended width)	kg		2.9		5.5
Height, without connectors	mm		256		306
Height, with connector	mm		290		340
Standard Width front/back	mm		65/70		99/105
Extended Width front/back	mm		95/100		99/105
Depth, without connectors	mm		185		228
Depth, with connectors	mm		<225		<265

6.4 Inputs/Outputs

Interface	Electrical Data
Analog inputs	<ul style="list-style-type: none"> • ± 12 VDC • Common Mode Rejection Ratio: > 30 dB at 60 Hz • resolution 16 bit and full monotonic • nonlinearity < 0.1% of full scale • offset drift max. $250\mu\text{V}/^\circ\text{C}$ • input impedance > 13 kOhms
Analog outputs	<ul style="list-style-type: none"> • ± 10 VDC • max 20mA • resolution 16 bit and full monotonic • nonlinearity < 0.1% of full scale • offset drift max. $250\mu\text{V}/^\circ\text{C}$ • short circuit protected to AGND • output impedance 110 Ohms
Digital inputs	<ul style="list-style-type: none"> • ON: 3.5 VDC to 30 VDC, 2 mA to 15 mA • OFF: -2 VDC to 2 VDC, max. 15 mA • galvanic isolation for 250 VDC
Digital outputs	<ul style="list-style-type: none"> • max. 30 VDC, 100 mA • short circuit proof • galvanic isolation for 250 VDC
Relay outputs	<ul style="list-style-type: none"> • max. 30 VDC, 1A • max. 42 VAC, 1 A • time open/close 10ms • isolation 400 VDC contact/coil

6.5 Electrical Data AKD-xzzz06

Electrical Data	Units	AKD-x00306	AKD-x00606	AKD-x01206	AKD-x02406
Rated supply voltage	V	3 x 120 V to 240 V \pm 10% 1 x 120 V to 240 V \pm 10%			3x240 V \pm 10%
Rated supply input frequency	Hz	50 Hz to 400 Hz \pm 5% or DC			
Rated input power for S1 operation	kVA	1.2	2.38	3.82	7.6
Rated input current					
at 1x120 V	A	5.0	9.9	12	N/A
at 1x240 V	A	5.0	9.9	12	N/A
at 3x120 V	A	2.3	4.6	9.2	N/A
at 3x240 V	A	2.3	4.6	9.2	18.3
Permitted switch on/off frequency	1/h	30			
Max. inrush current	A	10	10	10	20
Rated DC bus link voltage (Bus Turn on Delay 3ph 1 sec)	V	170 to 340			
Continuous output current (\pm 3%)					
at 120 V	Arms	3	6	12	N/A
at 240 V	Arms	3	6	12	24
Peak output current (for 5 s, \pm 3%)	Arms	9	18	30	48
Continuous output power					
at 1x120 V	W	312.5	625	1250	N/A
at 1x240 V	W	625	1250	2500	N/A
at 3x120 V	W	312.5	625	1250	N/A
at 3x240 V	W	625	1250	2500	5000
Peak output power (for 1 s)					
at 1x120 V	kVA	0.937	1.875	3.125	N/A
at 1x240 V	kVA	1.875	3.750	6.250	N/A
at 3x120 V	kVA	0.937	1.875	3.125	N/A
at 3x240 V	kVA	1.875	3.750	6.250	10
Technical data for regen circuit	—	→ p. 40			
Motor inductance min.					
at 120 V	mH	1.3	0.6	0.5	0.3
at 240 V	mH	2.5	1.3	1	0.6
Motor inductance max.					
Thermal dissipation, output stage disable	W	max. 20	max. 20	max. 20	max. 25
Thermal dissipation at rated current	W	31	57	137	175
Noise emission (low speed/high speed fan)	dB (A)	N/A	33/39	37/43	41/56
Aux. voltage supply	V	24 V (\pm 10%, check voltage drop)			
-current B, P, T types without/with motor brake	A	0.5 / 1.7	0.6 / 1.8	0.7 / 1.9	1.0 / 2.5
-current M type without/with motor brake	A	0.8 / 2.0	0.9 / 2.1	1.0 / 2.2	1.3 / 2.8

6.6 Electrical Data AKD-xzzz07

Electrical data	Units	AKD-x00307	AKD-x00607	AKD-x01207	AKD-x02407
Rated supply voltage	V	3 x 240 V to 480 V \pm 10%			
Rated supply input frequency	Hz	AC with 50 Hz to 400 Hz \pm 5% or DC			
Rated input power for S1 operation	kVA	2.24	4.49	7.65	15.2
Rated input current					
at 3x240 V	A	2.7	5.4	9.2	18.3
at 3x400 V	A	2.7	5.4	9.2	18.3
at 3x480 V	A	2.7	5.4	9.2	18.3
Permitted switch on/off frequency	1/h	30			
Max. inrush current	A	10	10	10	20
Rated DC bus link voltage (Bus Turn on Delay 3ph 1 sec)	V=	340 to 680			
Continuous output current (\pm 3%)					
at 240 V	Arms	3	6	12	24
at 400 V	Arms	3	6	12	24
at 480 V	Arms	3	6	12	24
Peak output current (for 5 s, \pm 3%)	Arms	9	18	30	48
Continuous output power					
at 3x240 V	kVA	0.6	1.25	2.5	5
at 3x400 V	kVA	1	2	4.2	8.3
at 3x480 V	kVA	1.2	2.5	5	10
Peak output power (for 1 s)					
at 3x240 V	kVA	1.8	3.75	6.25	10
at 3x400 V	kVA	3	6.75	10.4	16.7
at 3x480 V	kVA	3.6	7.5	12.5	20
Technical data for regen circuit	—	→ p. 40			
Motor inductance min.					
at 240 V	mH	3.2	1.6	1.3	0.6
at 400 V	mH	5.3	2.6	2.1	1
at 480 V	mH	6.3	3.2	2.5	1.2
Motor inductance max.	mH	600	300	250	120
Thermal dissipation, output stage disable	W	max. 20	max. 20	max. 20	max. 25
Thermal dissipation at rated current	W	102	129	153	237
Noise emission (low speed/high speed fan)	dB (A)	34/43	34/43	44/52	48/58
Aux. voltage supply	V=	24 V (\pm 10%, check voltage drop)			
-current B, P, T types without/with motor brake	A=	1 / 2.5	1 / 2.5	1 / 2.5	2 / 4
-current M type without/with motor brake	A=	1.3 / 2.8	1.3 / 2.8	1.3 / 2.8	2.3 / 4.3

6.7 Performance Data

AKD-xzzz06

Performance Data	Units	up to AKD-x00606	AKD-x01206	AKD-x02406
Switching frequency of output stage	kHz	10	8	8
Voltage rise speed dU/dt	kV/μs	2.5		4.3
Bandwidth of current controller	kHz	2.5 to 4	2 to 3	
Bandwidth of velocity controller (scalable)	Hz	0 to 1000	0 to 800	0 to 600
Bandwidth of position controller (scalable)	Hz	1 to 250		

AKD-xzzz07

Performance Data	Units	AKD-x00307	AKD-x00607	AKD-x01207	AKD-x02407
Switching frequency of output stage	kHz	8	8	6	8
Voltage rise speed dU/dt	kV/μs	7.2			
Bandwidth of current controller	kHz	2.5 to 4		2 to 3	
Bandwidth of velocity controller (scalable)	Hz	0 to 800	0 to 600		
Bandwidth of position controller (scalable)	Hz	1 to 250			

6.8 Recommended Tightening Torques

Connector	Tightening Torque/Nm		
	up to AKD-x00606	AKD-x01206	AKD-x02406 and AKD-xzzz07
X1	0.22 to 0.25	0.22 to 0.25	0.22 to 0.25
X2	0.5 to 0.6	0.7 to 0.8	0.7 to 0.8
X3	0.5 to 0.6	0.5 to 0.6	0.7 to 0.8
X4	-	-	0.7 to 0.8
X7, X8, X21, X22, X23, X24, X35, X36	0.2 to 0.25	0.2 to 0.25	0.2 to 0.25
PE block	1.7	1.7	1.7

See "Conformance with UL/cUL" (→ p. 21) for in-lbs values.

6.9 Fusing

US fuses: Class J, 600 VAC 200 kA, time-delay. The fuse must be UL and CSA listed, UL recognized is not sufficient.

EU fuses: types gRL or gL, 400 V/500 V, time-delay

Fuse holders: Combined with the standard fuse blocks, finger safe fuse holders must be used according to IEC 60529.

Examples:

Bussmann: CH Series Modular Fuse Holders, fuse size 0 to 30A class J, 3 poles: CH30J3

Ferraz: Ultrasafe Fuse holders, fuse size 0 to 30A class J, 3 poles: US3J3I

6.9.1 External power supply fusing

Drive Model	Max. Ampere rating	Example class J Cooper Bussmann	Example class J Ferraz Shawmut
AKD-x00306	10A (Time-Delay)	LPJ10SP/DFJ10	AJT10/HSJ10
AKD-x00606	15A (Time-Delay)	LPJ15SP/DFJ15	AJT15/HSJ15
AKD-x01206	15A (Time-Delay)	LPJ15SP/DFJ15	AJT15/HSJ15
AKD-x02406	30A (Time-Delay)	LPJ30SP/DFJ30	AJT30/HSJ30
AKD-x00307	6A (Time-Delay)	LPJ6SP/DFJ6	AJT6/HSJ6
AKD-x00607	10A (Time-Delay)	LPJ10SP/DFJ10	AJT10/HSJ10
AKD-x01207	15A (Time-Delay)	LPJ15SP/DFJ15	AJT15/HSJ15
AKD-x02407	30A (Time-Delay)	LPJ30SP/DFJ30	AJT30/HSJ30

6.9.2 External 24 V supply fusing

Drive Model	Max. Ampere rating	Example class J Cooper Bussmann	Example class J Ferraz Shawmut
all AKD	8A (Time-Delay)	LPJ8SP/DFJ8	AJT8

6.9.3 External regen resistor fusing

Drive Model	Ampere rating	UL region	CE Region
AKD-x003 to -x012	10A	example: Cooper Bussmann type FWP-xxA14F	example: Siba 110V to 400V: gRL(gS) 400V to 480V: aR
AKD-x024	15A		

6.10 Grounding System

There are several ground networks in the drive:

AGND	analog ground
DCOM7, DCOM8	common line for digital inputs on I/O connector X7, X8
DCOM21, DCOM22	common line for digital inputs on I/O connector X21, X22 (I/O option card only)
DCOM35, DCOM36	common line for digital inputs on I/O connector X35, X36(AKD-M only)
GND	24 V supply, STO input, holding brake
0 V	internal digital ground, encoder emulation output, service channel

6.11 Connectors

Given voltage and current data are the lowest values allowed by UL and CE.

AKD-xzzz06 Types (120V to 240V Mains Voltage Supply)

Connector	Type	Max. Cross Section ¹	Current ²	Voltage ³
Control signals X7/X8	Terminal Connector, 10 poles	1.5 mm ² , 16 awg	10 A	250 V
Control signals X21/X22*	Terminal Connector, 8 poles	1.5 mm ² , 16 awg	10 A	250 V
Control signals X23/X24*	Terminal Connector, 14 poles	1.5 mm ² , 16 awg	10 A	250 V
Control signals X35/X36**	Terminal Connector, 8 poles	1.5 mm ² , 16 awg	10 A	250 V
Aux. voltage X1	Terminal Connector, 3 poles	1.5 mm ² , 16 awg	8 A	160 V
Motor X2 (3 to 6 A)	Terminal Connector, 6 poles	2.5 mm ² , 14 awg	10 A	300 V
Motor X2 (12 to 24 A)	Terminal Connector, 6 poles	10 mm ² , 8 awg	30 A	600 V
Power X3 (3 to 6A)	Terminal Connector, 7 poles	2.5 mm ² , 14 awg	10 A	300 V
Power X3 (12 A)	Terminal Connector, 8 poles	2,5 mm ² , 14 awg	16 A	300 V
Power X3 (24 A)	Terminal Connector, 4 poles	10 mm ² , 8 awg	30 A	600 V
Power X4 (24 A)	Terminal Connector, 4 poles	10 mm ² , 8 awg	30 A	600 V
Feedback X10	SubD 15pin HD (female)	0,5 mm ² , 21 awg	1 A	<100 V
Service Port X11, X32*	RJ45	0,5 mm ² , 21 awg	1 A	<100 V
Motion Bus X5, X6	RJ45	0,5 mm ² , 21 awg	1 A	<100 V
CAN In/Out X12/13	RJ25	0,5 mm ² , 21 awg	1 A	<100 V
Encoder Emulation X9	SubD 9pin (male)	0,5 mm ² , 21 awg	1 A	<100 V

AKD-xzzz07 Types (240V to 480V Mains Voltage Supply)

Connector	Type	Max. Cross Section ¹	Current ²	Voltage ³
Control signals X7/X8	Terminal Connector, 10 poles	1.5 mm ² , 16 awg	10 A	250 V
Control signals X21/X22*	Terminal Connector, 8 poles	1.5 mm ² , 16 awg	10 A	250 V
Control signals X23/X24*	Terminal Connector, 14 poles	1.5 mm ² , 16 awg	10 A	250 V
Control signals X35/X36**	Terminal Connector, 8 poles	1.5 mm ² , 16 awg	10 A	250 V
Aux. voltage X1	Terminal Connector, 3 poles	1.5 mm ² , 16 awg	8 A	160 V
Motor X2	Terminal Connector, 6 poles	10 mm ² , 8 awg	30 A	600 V
Power X3, X4	Terminal Connector, 4 poles	10 mm ² , 8 awg	30 A	600 V
Feedback X10	SubD 15pin HD (female)	0,5 mm ² , 21 awg	1 A	<100 V
Service Port X11, X32*	RJ45	0,5 mm ² , 21 awg	1 A	<100 V
Motion Bus X5, X6	RJ45	0,5 mm ² , 21 awg	1 A	<100 V
CAN In/Out X12/13	RJ25	0,5 mm ² , 21 awg	1 A	<100 V
Encoder Emulation X9	SubD 9pin (male)	0,5 mm ² , 21 awg	1 A	<100 V

¹single-line connection

²single-line connection with recommended conductor cross section (→ p. 39)

³rated voltage with pollution level 2

* with I/O option card "IC" only

** with AKD-M variant only

6.12 Cable and Wire Requirements

6.12.1 General

For information on the chemical, mechanical, and electrical characteristics of the cables please refer to the accessories manual or contact customer support.

NOTE

To reach the maximum permitted cable length, you must use cable material with the following capacitance (phase to shield) requirements:

- Motor cable: less than 150 pF/m
- Resolver/Encoder cable: less than 120 pF/m

Motor cables longer than 25 m may require the use of a motor choke.

6.12.2 Cable cross sections and requirements

The table below describes the recommended interface cross sections and cable requirements for single-axis systems in accordance with IEC 60204. For multi-axis systems, observe the specific operating conditions for your system.

Interface	Cross Section	Cable Requirements
AC connection	up to AKD-x006: 1.5 mm ² (16 awg) AKD-x012: 2.5 mm ² (14 awg) AKD-x024: 4 mm ² (12 awg)	600 V, minimum 75°C
DC bus link, regen resistor	up to AKD-x006: 1.5 mm ² (16 awg) AKD-x012 to 24: 2.5 mm ² (14 awg)	1000 V, minimum 75°C, shielded for lengths >0.20 m
Motor cables without choke, max. 25 m	up to AKD-x006: 1.5 mm ² (16 awg) AKD-x012: 2.5 mm ² (14 awg) AKD-x024: 4 mm ² (12 awg)	600 V, minimum 75°C, shielded, capacitance <150 pF/m
Motor cables with choke, 25 - 50 m	up to AKD-x006: 1.5 mm ² (16 awg) AKD-x012: 2.5 mm ² (14 awg) AKD-x024: 4 mm ² (12 awg)	600 V, minimum 75°C, shielded, capacitance <150 pF/m
Resolver, max. 100 m	4x2x0.25 mm ² (24 awg)	twisted pairs, shielded, capacitance <120 pF/m
SFD, max. 50 m	1x2x0.25 mm ² (24 awg) 1x2x0.50 mm ² (21 awg)	twisted pairs, shielded
Encoder, max. 50 m	7x2x0.25 mm ² (24 awg)	twisted pairs, shielded
ComCoder, max. 25 m	8x2x0.25 mm ² (24 awg)	twisted pairs, shielded
Analog I/Os, max. 30 m	0.25 mm ² (24 awg)	twisted pairs, shielded
Digital I/Os, max. 30 m	0.5 mm ² (21 awg)	single line
Holding brake (motor)	min. 0.75 mm ² (19 awg)	600 V, minimum 75°C, shielded
+24 V / GND, max 30 m	max. 2.5 mm ² (14 awg)	single line

6.13 Dynamic Braking

Dynamic braking is a method to slow down a servo system by dissipating the mechanical energy driven by the motor back EMF. The AKD has a built in advanced dynamic braking mode which operates fully in hardware. When activated, the drive shorts the motor terminals in phase with the back EMF (q axis) but continues to operate the non-force producing current loop (d-axis) with 0 current. This forces all of the dynamic braking current to be stopping current and insures the fastest stopping/amp of motor terminal current.

- When current is not being limited, the mechanical energy is being dissipated in the motor resistance.
- When current is being limited, energy is returned to the drive bus capacitors.
- The drive also limits the maximum dynamic braking motor terminal current via the *DRV.DBILIMIT* parameter to insure that the drive, motor, and customer load do not see excessive currents/forces.

Whether and how the AKD uses dynamic braking depends on (*DRV.DISMODE*).

6.13.1 Regen circuit

When the amount of returned energy builds the bus capacitor voltage up enough the drive activates the regen circuit to start dumping the returned energy in the regen resistor (also called regenerative or brake resistor). This resistor could be internal or connected external to the drive, depending on drive model and drive wiring.

AKD-x00306 to AKD-x00606

No internal regen resistor. Depending on the application requirements, an external resistor can be connected.

AKD-x01206 to AKD-x02406 and AKD-xzzz07

With internal resistor plus the ability to connect an external resistor depending on the application requirements.

External regen resistors are described in the regional *AKD Accessories Manual*.

6.13.1.1 Functional description

When the amount of returned energy builds the bus capacitor voltage up enough the drive activates the brake chopper to start dumping the returned energy in the regen resistor.

1. Individual drives, not coupled through the DC bus link circuit (+DC, -DC)

When the energy fed back from the motor has an average or peak power that exceeds the preset level for the regen power rating, the drive generates the warning "n521 Regen Over power". If the power increases past the fault level, the regen circuit will switch off.

With the regen circuit switched off, the drive internal DC bus link voltage is supervised. The drive reports an over-voltage fault if the DC bus threshold is exceeded. The drive power stage is disabled and the load coasts to a stop with the fault message "F501 Bus Over voltage" (→ p. 180). The Fault contact (terminals X8/9-10) is opened (→ p. 135) due to this fault.

2. Several drives coupled through the DC bus link (+DC, -DC)

Using the built-in regen circuit, several drives of the same series can be operated from a common DC-bus link (→ p. 94), without any additional measures. 90% of the combined power of all the coupled drives is always available for peak and continuous power. The switch-off on over voltage takes place as described under 1. (above) for the drive that has the lowest switch-off threshold (resulting from tolerances).

6.13.1.2 Technical data for AKD-xzzz06

Technical data for the regen circuit depends on the drive type and the mains voltage. Supply voltages, capacitances, and switch-on voltages are all nominal values.

NOTE

Observe the regeneration time (some minutes) for the dynamic brake circuit after full load with peak regen power.

Brake circuit			Supply voltage
Type	Rated data	Units	120 V / 240 V
AKD-xzzz06 all types	Switch-on threshold of regen circuit	V	380
	Overvoltage limit	V	420
	Maximum regen duty cycle	%	15*
Type	Rated data	Units	120 V / 240 V
AKD-x00106	External regen resistor	Ohm	33
	Maximum continuous regen power, external resistor	kW	0.48
	Peak regen power, external (1s)	kW	5.4
	Absorption energy in capacitors (+/- 20%)	Ws	60 / 20
	DC Bus Capacitance	µF	940
AKD-x00306	External regen resistor	Ohm	33
	Maximum continuous regen power, external resistor	kW	0.77
	Peak regen power, external (1s)	kW	5.4
	Absorption energy in capacitors (+/- 20%)	Ws	60 / 20
	DC Bus Capacitance	µF	940
AKD-x00606	External regen resistor	Ohm	33
	Maximum continuous regen power, external resistor	kW	1.5
	Peak regen power, external resistor (1s)	kW	5.4
	Absorption energy in capacitors (+/- 20%)	Ws	60 / 20
	DC Bus Capacitance	µF	940
AKD-x01206	Internal regen resistor	Ohm	15
	Continuous power, internal resistor	W	100
	Peak regen power, internal resistor (0.5s)	kW	11.7
	External regen resistor	Ohm	33
	Maximum continuous regen power, external resistor	kW	3
	Absorption regen power, external resistor (1s)	kW	5.4
	Storeable energy in capacitors (+/- 20%)	Ws	160 / 55
	DC Bus Capacitance	µF	2460
AKD-x02406	Internal regen resistor	Ohm	8
	Continuous power, internal resistor	W	200
	Peak regen power, internal resistor (0.5s)	kW	22
	External regen resistor	Ohm	15
	Maximum continuous regen power, external resistor	kW	6
	Peak regen power, external resistor (1s)	kW	11.8
	Absorption energy in capacitors (+/- 20%)	Ws	180 / 60
	DC Bus Capacitance	µF	2720

* depends on connected regen resistor power

6.13.1.3 Technical data for AKD-xzzz07

Technical data for the regen circuit depends on the drive type and the mains voltage. Supply voltages, capacitances, and switch-on voltages are all nominal values.

NOTE

Observe the regeneration time (some minutes) after full load with peak regen power.

Brake circuit			Supply voltage	
Type	Rated data	Units	240 V	400 V / 480 V
AKD-xzzz07 all types	Switch-on threshold of regen circuit	V	380	760
	Overvoltage limit	V	420	840
	Maximum regen duty cycle	%	15*	
Type	Rated data	Units	240 V	400 V / 480 V
AKD-x00307	Internal regen resistor	Ohm	33	
	Continuous power, internal resistor	W	80	
	Peak regen power, internal resistor (0.5s)	kW	5.5	22.1
	External regen resistor	Ohm	33	
	Maximum continuous regen power, external resistor	kW	0.77	1.5
	Peak regen power, external (1s)	kW	5,4	21.4
	Absorption energy in capacitors (+/- 20%)	Ws	5	35 / 20
	DC Bus Capacitance	µF	235	
AKD-x00607	Internal regen resistor	Ohm	33	
	Continuous power, internal resistor	W	100	
	Peak regen power, internal resistor (0.5s)	kW	5.4	21.4
	External regen resistor	Ohm	33	
	Maximum continuous regen power, external resistor	kW	1.5	3
	Peak regen power, external resistor (1s)	kW	5.4	21.4
	Absorption energy in capacitors (+/- 20%)	Ws	5	35 / 20
	DC Bus Capacitance	µF	235	
AKD-x01207	Internal regen resistor	Ohm	33	
	Continuous power, internal resistor	W	100	
	Peak regen power, internal resistor (0.5s)	kW	5.4	21.4
	External regen resistor	Ohm	33	
	Maximum continuous regen power, external resistor	kW	3	6
	Peak regen power, external resistor (1s)	kW	5.4	21.4
	Absorption energy in capacitors (+/- 20%)	Ws	10	70 / 40
	DC Bus Capacitance	µF	470	
AKD-x02407	Internal regen resistor	Ohm	23	
	Continuous power, internal resistor	W	200	
	Peak regen power, internal resistor (0.5s)	kW	7.7	30.6
	External regen resistor	Ohm	23	
	Maximum continuous regen power, external resistor	kW	6	12
	Peak regen power, external resistor (1s)	kW	7.7	30.6
	Absorption energy in capacitors (+/- 20%)	Ws	15	110 / 60
	DC Bus Capacitance	µF	680	

* depends on connected regen resistor power

6.14 Switch-On and Switch-Off Behavior

This chapter describes the switch-on and switch-off behavior of the AKD.

Behavior of “holding brake” function

Drives with an enabled holding brake function have a special timing for switching on and off the output stage (→ p. 102). Events that remove the DRV.ACTIVE signal trigger the holding brake to apply. As with all electronic circuits, the general rule applies that there is a possibility of the internal holding brake module failing.

Functional safety, e.g. with hanging load (vertical axes), requires an additional mechanical brake which must be safely operated, for example by a safety control.

If velocity drops below threshold *CS.VTHRESH* or timeout occurs during a stop procedure, the brake is applied. Set parameter MOTOR.BRAKEIMM to 1 with vertical axes, to apply the motor holding brake (→ p. 102) immediately after faults or Hardware Disable.

Behavior when undervoltage condition is present

The behavior in an undervoltage condition depends on the VBUS.UVMODE setting.

VBUS.UVMODE	DC Bus Undervoltage Mode. Consult the <i>AKD User Guide</i> for configuring the parameter.
0	The drive will report a F502 undervoltage fault any time an undervoltage condition occurs.
1 (default)	The drive will report a warning n502 if not enabled. The drive will report a fault if the drive is enabled when the condition occurs, or an attempt is made to enable while an under voltage condition occurs.

Safety function STO

With the functional safe function STO, the drive can be secured on standstill using its internal electronics so that even when power is being supplied, the drive shaft is protected against unintentional restart. The chapter “Safe Torque Off (STO)” describes how to use the STO function (→ p. 52).

6.14.1 Switch-on behavior in standard operation

The diagram below illustrates the correct functional sequence for switching the drive on.

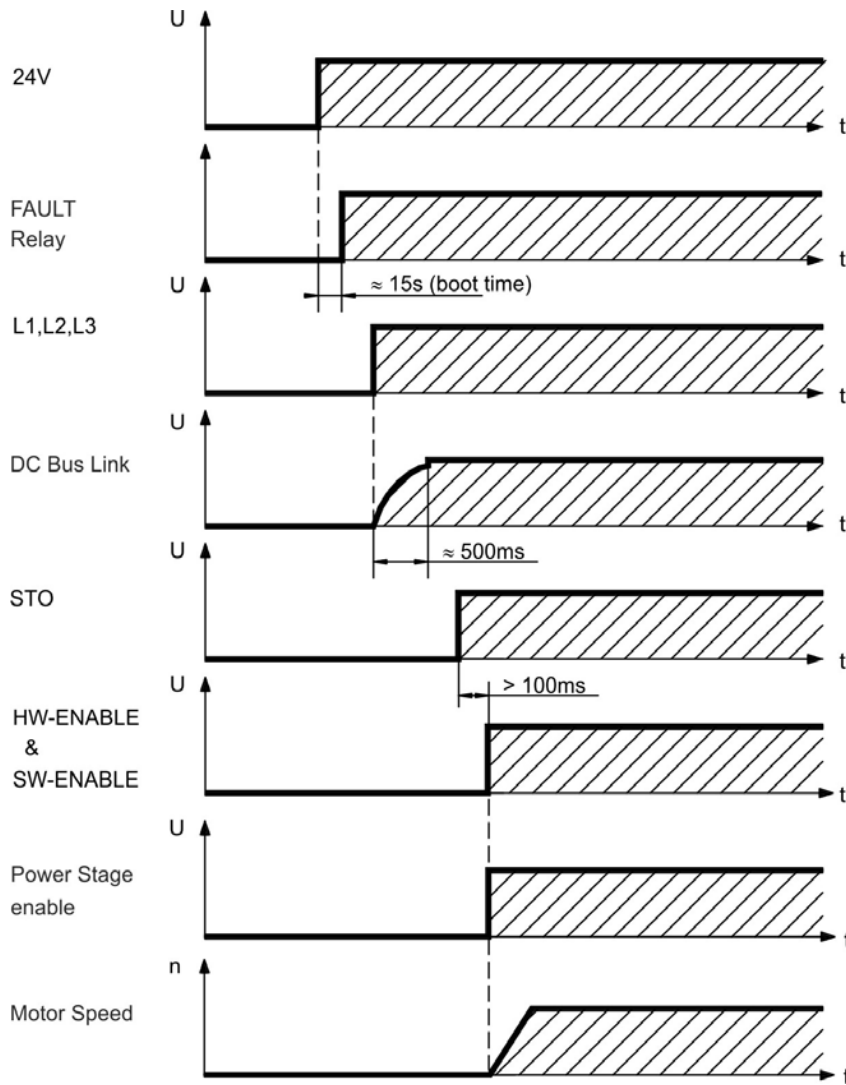

Fault F602 occurs when STO (\rightarrow p. 52) does not have current when HW enable becomes active.

6.14.2 Switch-off behavior

NOTE The drive's 24 V supply must remain constant. Hardware Enable input disables the power stage immediately. Configured Digital Inputs and fieldbus commands can be used to perform controlled stops.

6.14.2.1 Switch-off behavior using the DRV.DIS command

The enable/disable button in WorkBench issues a *drv.dis* command internally to the drive. See *AKD User Guide* for configuring inputs and software commands. Sometimes this enable signal is called "Software Enable" (SW-Enable).

DRV.DISMODE	DRV.DISMODE controls the behavior of the <i>drv.dis</i> command issued through WorkBench, or terminal, or fieldbus. Consult the <i>AKD User Guide</i> for configuring.
0	Disable axis immediately, if velocity drops below threshold <i>CS.VTHRESH</i> or timeout occurs brake is applied. Category 0 stop according to IEC 60204(→ p. 50).
2	Use controlled stop to disable drive, if velocity drops below threshold <i>CS.VTHRESH</i> or timeout occurs brake is applied. Category 1 stop according to IEC 60204(→ p. 50).

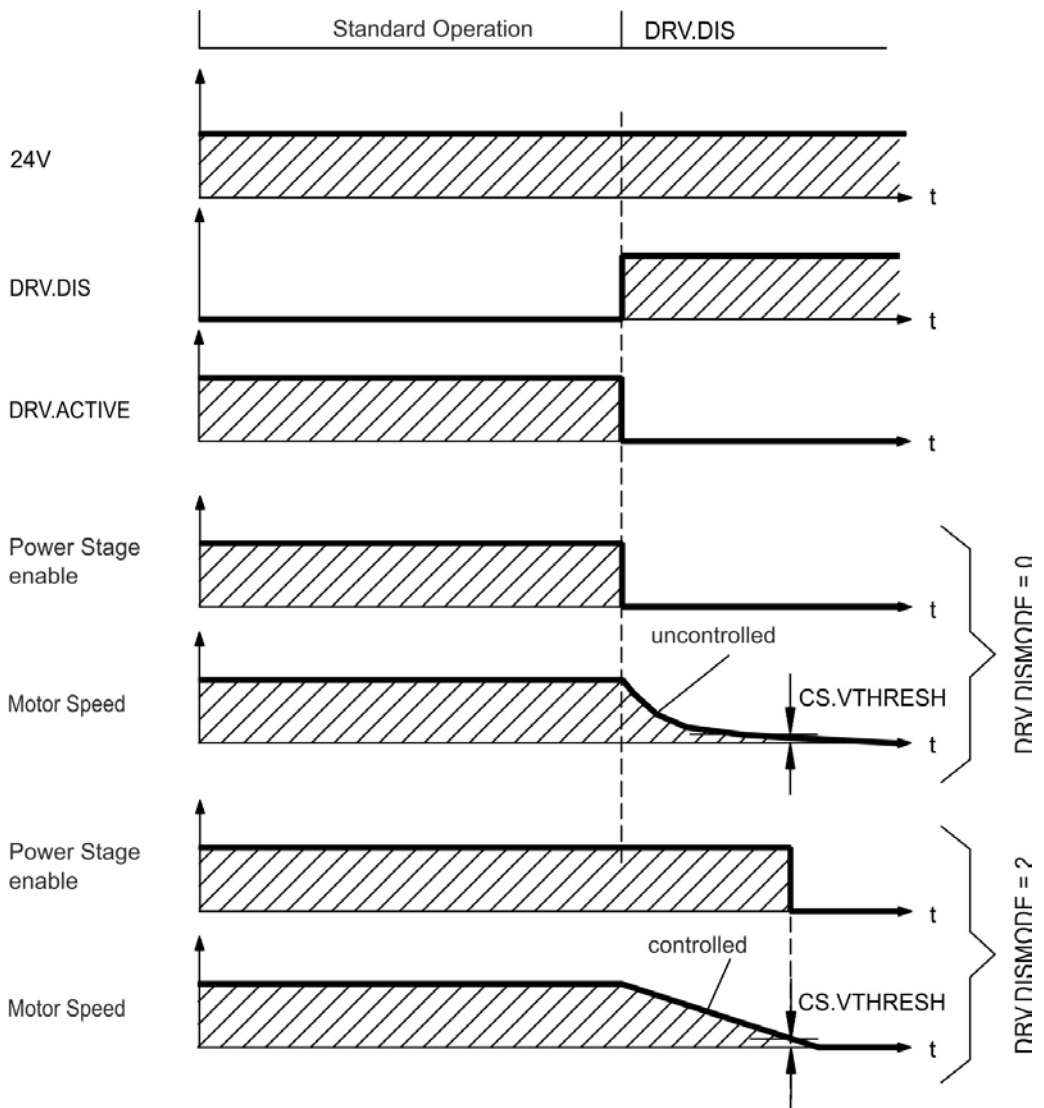

If velocity drops below threshold *CS.VTHRESH* or timeout occurs brake is applied (→ p. 102).

6.14.2.2 Switch-off behavior using a digital input (controlled stop)

This is a category 2 stop according to IEC 60204 (→ p. 50).

A digital input can be configured to bring the motor to a controlled stop and then disable the drive and apply the holding brake.(if present). See the *AKD User Guide* for information on configuring Digital Inputs.

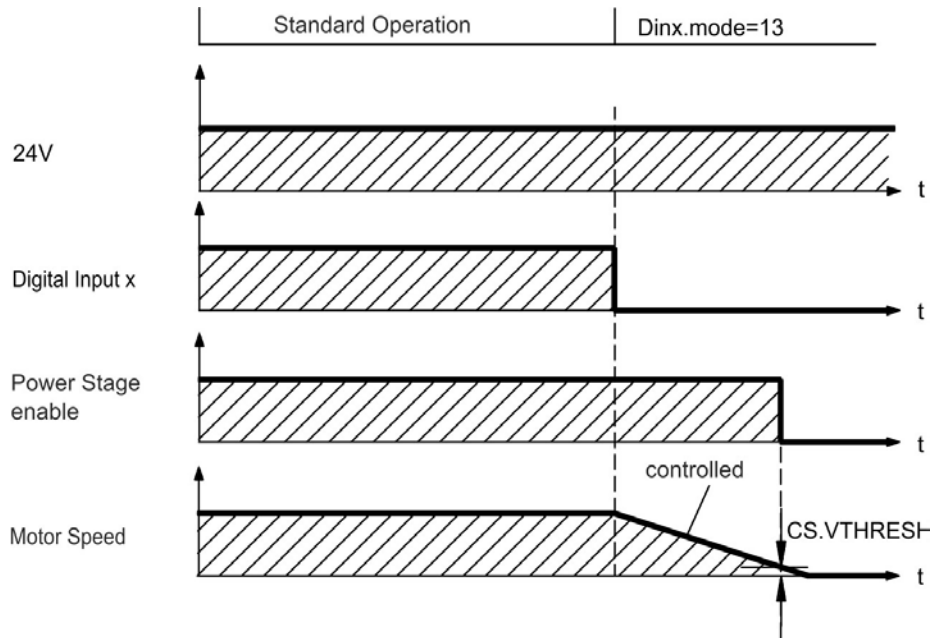

If velocity drops below threshold *CS.VTHRESH* or timeout occurs brake is applied (→ p. 102).

6.14.2.3 Switch-off behavior using HW Enable input (uncontrolled stop)

This is a category 0 stop according to IEC 60204 (→ p. 50).

The hardware enable input disables the power stage immediately.

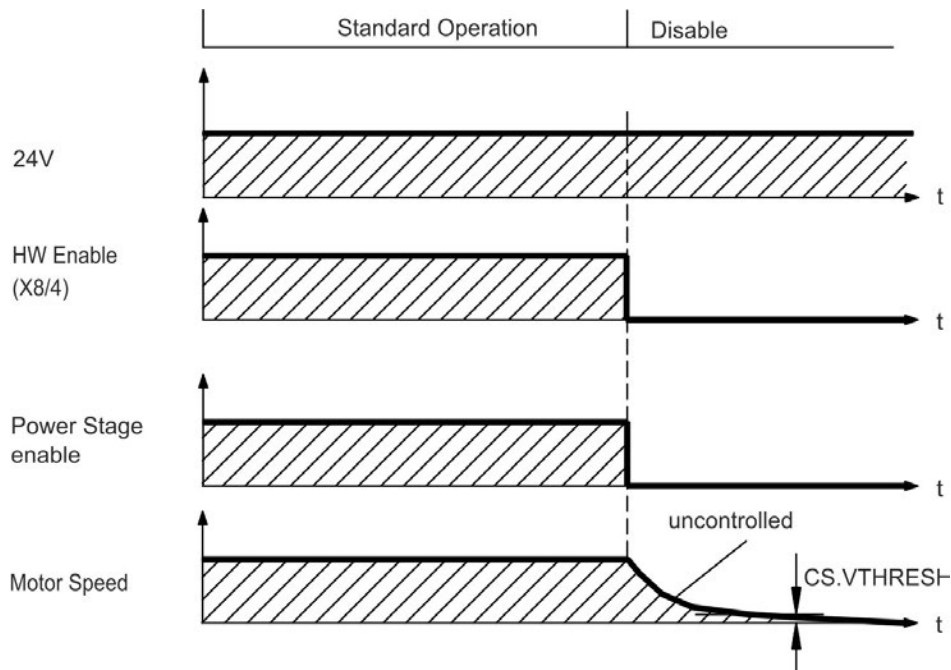

If velocity drops below threshold *CS.VTHRESH* or timeout occurs the motor holding brake is applied (→ p. 102). Set parameter *MOTOR.BRAKEIMM* to 1 with vertical axes, to apply the motor holding brake immediately after Hardware Disable.

6.14.2.4 Switch-off behavior in the event of a fault

The behavior of the drive always depends on the fault type and the setting of a number of different parameters (DRV.DISMODE, VBUS.UVFTHRESH, CS.VTHRESH, and others; see the *AKD User Guide* or WorkBench help for more details). See the *Drive Fault and Warning Messages and Remedies* section of the *AKD User Guide* for a table describing the specific behavior of each fault.

The following pages show examples for the possible fault behaviors.

Switch-off behavior for faults that cause an immediate power stage disable

This is a category 0 stop according to IEC 60204 (→ p. 50).

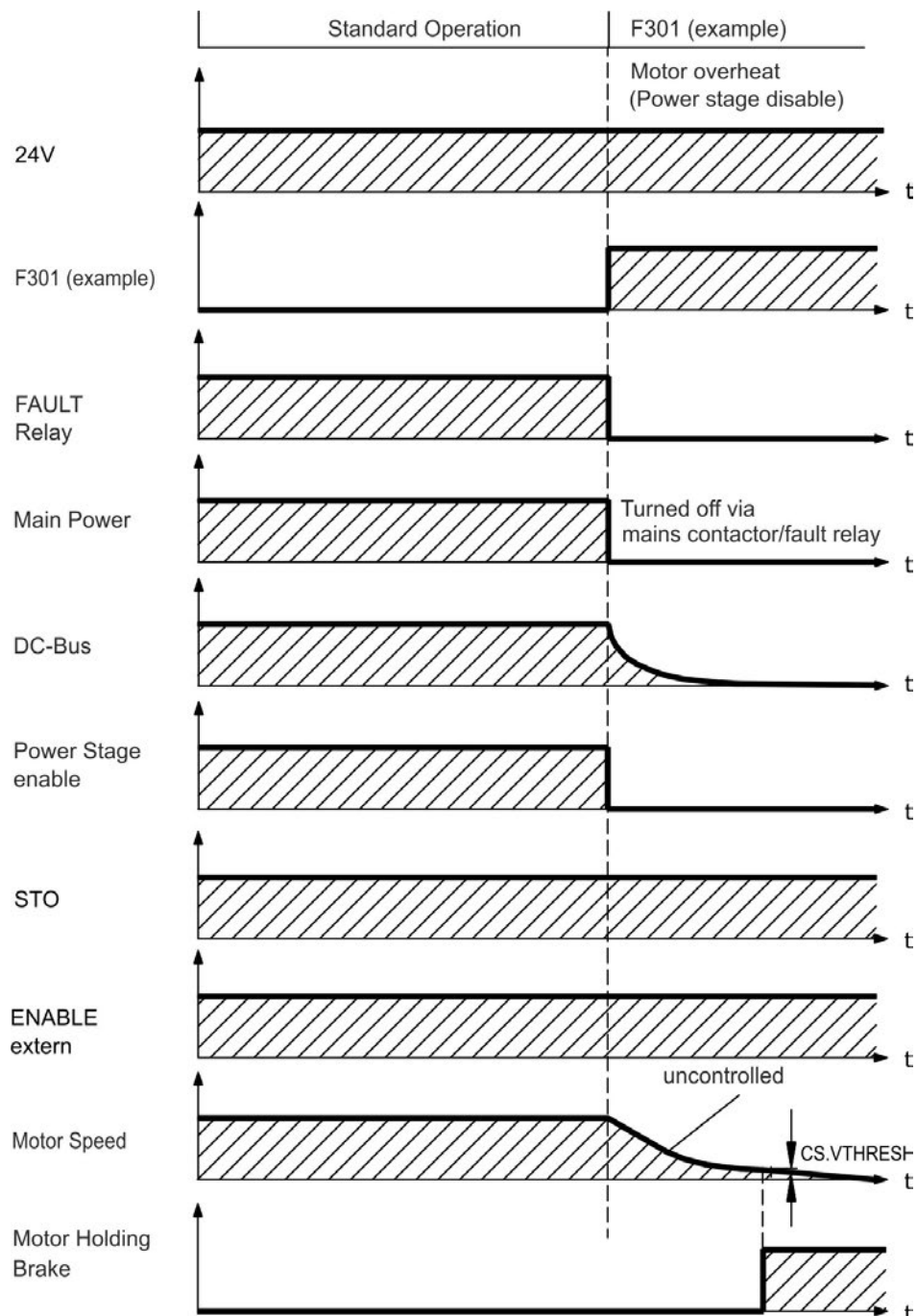

If velocity drops below threshold $CS.VTHRESH$ or timeout occurs the motor holding brake is applied (→ p. 102). Set parameter `MOTOR.BRAKEIMM` to 1 with vertical axes, to apply the motor holding brake immediately after faults.

Switch-off behavior for faults that cause dynamic braking

This is a category 0 stop according to IEC 60204 (→ p. 50).

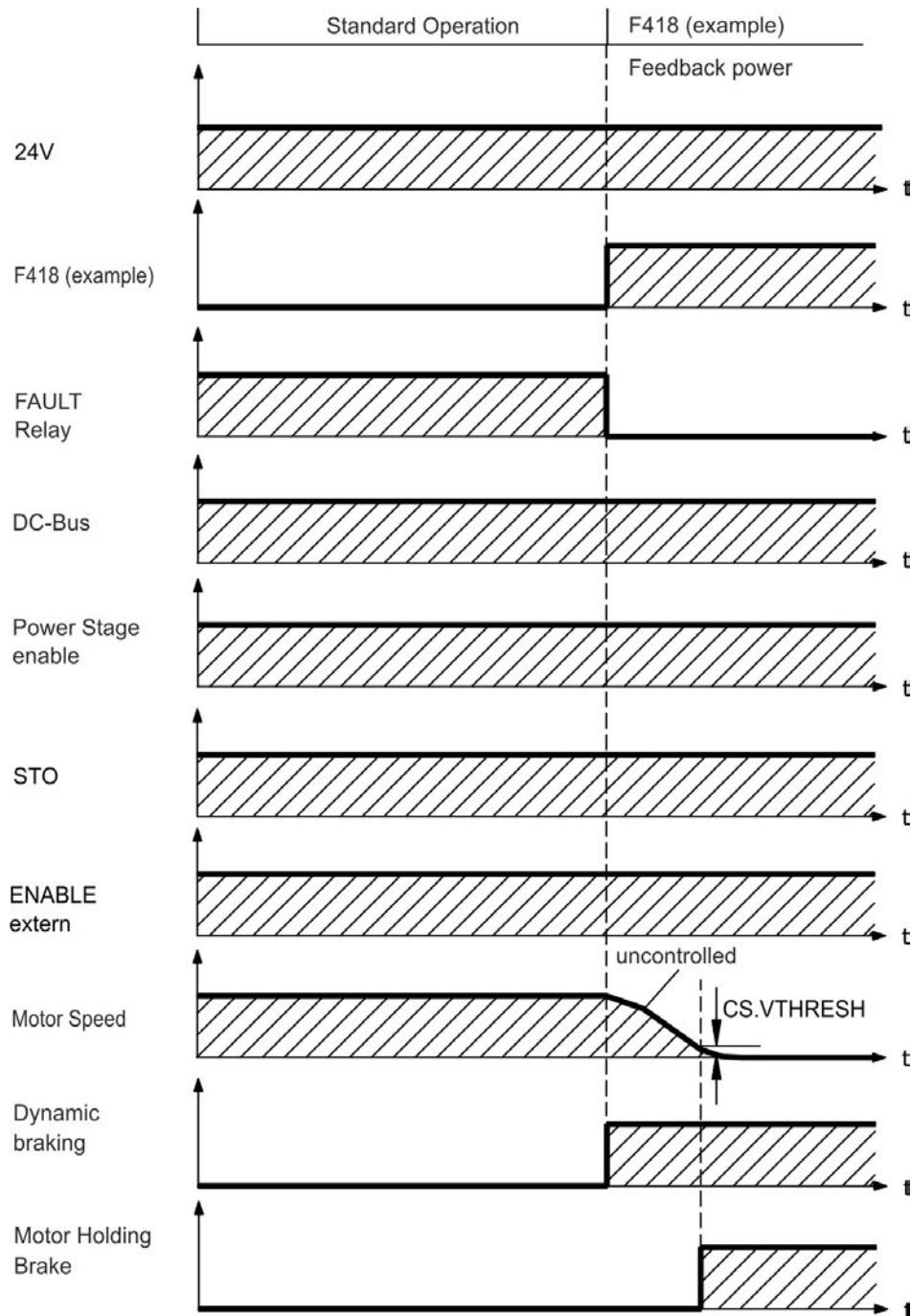

If velocity drops below threshold $CS.VTHRESH$ or timeout occurs brake is applied (→ p. 102).

Switch-off behavior for faults that cause a controlled stop

This is a category 1 stop according to IEC 60204 (→ p. 50).

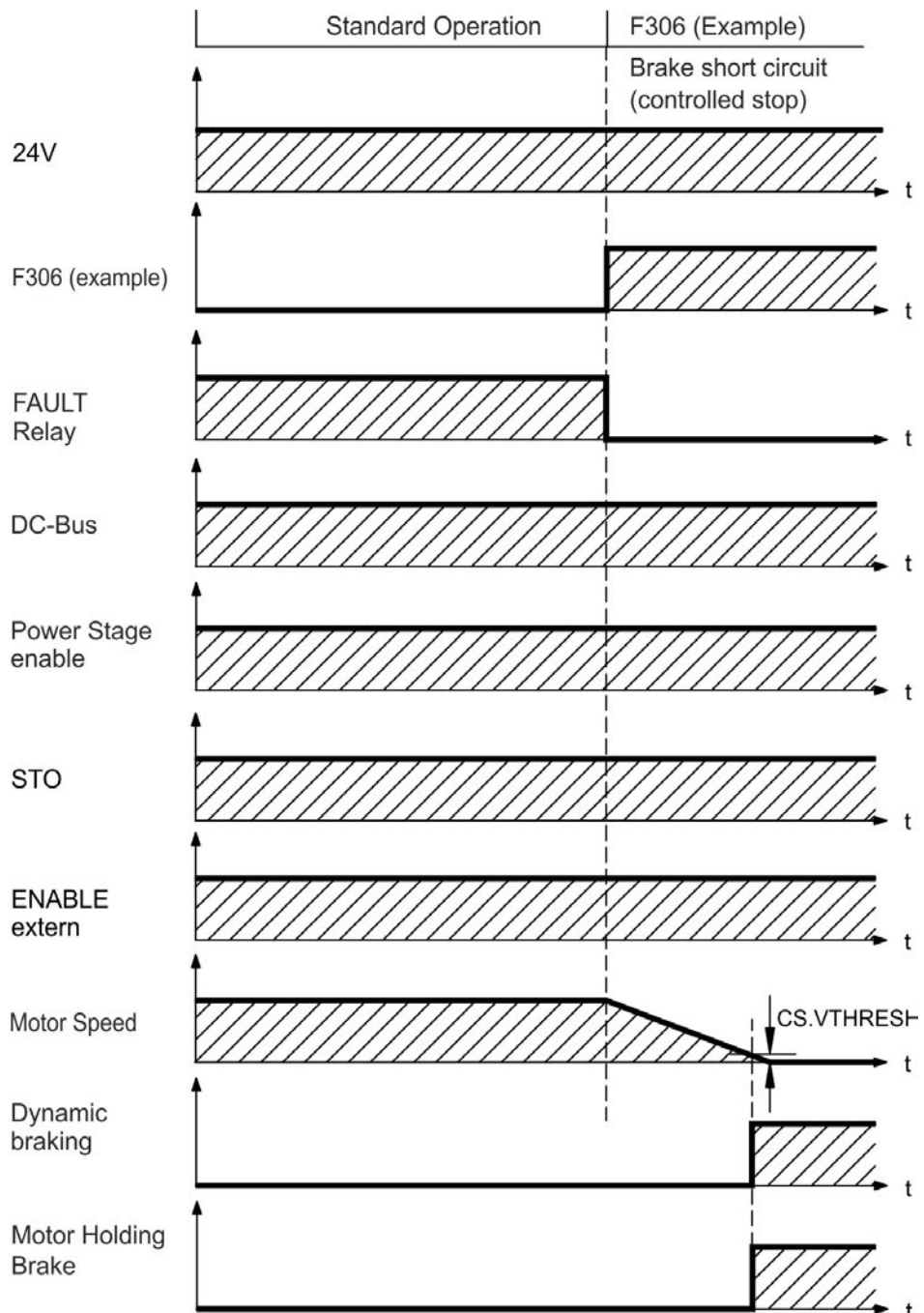

If velocity drops below threshold $CS.VTHRESH$ or timeout occurs brake is applied (→ p. 102).

6.15 Stop / Emergency Stop / Emergency Off

The control functions Stop, Emergency Stop and Emergency Off are defined by IEC 60204. Notes for safety aspects of these functions can be found in ISO 13849 and IEC 62061.

NOTE

The parameter DRV.DISMODE must be set to 2 to implement the different stop categories. Consult the *AKD User Guide* for configuring the parameter.



WARNING

With vertical load the load could fall. Serious injury could result when the load is not properly blocked. Functional safety, e.g. with hanging load (vertical axes), requires an additional mechanical brake which must be safely operated, for example by a safety control.

Set parameter MOTOR.BRAKEIMM to 1 with vertical axes, to apply the motor holding brake (→ p. 102) immediately after faults or Hardware Disable.

6.15.1 Stop

The stop function shuts down the machine in normal operation. The stop function is defined by IEC 60204.

NOTE

The Stop Category must be determined by a risk evaluation of the machine.

Stop function must have priority over assigned start functions. The following stop categories are defined:

Stop Category 0

Shut-down by immediate switching-off the energy supply to the drive machinery (this is an uncontrolled shut-down). With the approved safety function STO (→ p. 52) the drive can be stopped using its internal electronics (IEC 61508 SIL2).

Stop Category 1

A controlled shut-down, whereby the energy supply to the drive machinery is maintained to perform the shut-down, and the energy supply is only interrupted when the shut-down has been completed.

Stop Category 2

A controlled shut-down, whereby the energy supply to the drive machinery is maintained.

Stop Category 0 and Stop Category 1 stops must be operable independently of the operating mode, whereby a Category 0 stop must have priority.

If necessary, provision must be made for the connection of protective devices and lock-outs. If applicable, the stop function must signal its status to the control logic. A reset of the stop function must not create a hazardous situation.

6.15.2 Emergency Stop

The Emergency Stop function is used for the fastest possible shutdown of the machine in a dangerous situation. The Emergency Stop function is defined by IEC 60204. Principles of emergency stop devices and functional aspects are defined in ISO 13850.

The Emergency Stop function will be triggered by the manual actions of a single person. It must be fully functional and available at all times. The user must understand instantly how to operate this mechanism (without consulting references or instructions).

NOTE

The Stop Category for the Emergency Stop must be determined by a risk evaluation of the machine.

In addition to the requirements for stop, the Emergency Stop must fulfil the following requirements:

- Emergency Stop must have priority over all other functions and controls in all operating modes.
- The energy supply to any drive machinery that could cause dangerous situations must be switched off as fast as possible, without causing any further hazards (Stop Category 0) or must be controlled in such a way, that any movement that causes danger, is stopped as fast as possible (Stop Category 1).
- The reset must not initiate a restart.

6.15.3 Emergency Off

The Emergency Off function is used to switch-off the electrical power supply of the machine. This is done to prevent users from any risk from electrical energy (for example electrical impact). Functional aspects for Emergency Off are defined in IEC 60364-5-53.

The Emergency Off function will be triggered by the manual actions of a single person.

NOTE

The result of a risk evaluation of the machine determines the necessity for an Emergency Off function.

Emergency Off is done by switching off the supply energy by electro-mechanical switching devices. This results in a category 0 stop. If this stop category is not possible in the application, then the Emergency Off function must be replaced by other measures (for example by protection against direct touching).

6.16 Safe Torque Off (STO)

An additional digital input (STO) releases the power output stage of the drive as long as a 24 V signal is applied to this input. If the STO input goes open-circuit, then power will no longer be supplied to the motor, and the drive will lose all torque and coast to a stop.

Input STO (X1/3)

- Floating, reference ground is GND
- 24 V \pm 10%, 20 mA

NOTE

This input is not compatible with IEC 61131-2.

You can thus achieve a category 0 stop (\rightarrow p. 50) by using the STO input without switching a mains contactor.

Advantages of the STO function:

- The DC bus link remains charged, since the mains supply line remains active.
- Only low voltages are switched, so there is no contact wear.
- Very little wiring is required.

The STO safety implementation on the AKD is certified. The safety circuit implementation used for the safety function "Safe Torque Off" in the drive is suited for SIL 2 according to IEC 61508-2 and PLd / CAT3 according to ISO 13849-1.

6.16.1 Safety characteristic data

The subsystems (AKD) are described with the following characteristic data:

Device	Operation Mode	ISO 13849-1	IEC 61508-2	PFH [1/h]	T _M [Years]	SFF [%]
STO	STO single channel	PL d, CAT 3	SIL 2	0	20	100

6.16.2 Use as directed

The STO function is exclusively intended to provide a functional safe stop of the motion system. To achieve this functional safety, the wiring of the safety circuits must meet the safety requirements of IEC 60204, ISO 12100 and ISO 13849.

6.16.3 Prohibited use

The STO function must not be used if the drive is to be made inactive for the following reasons:

- Cleaning, maintenance and repair operations, long inoperative periods. In such cases, the entire system should be disconnected from the supply and secured (main switch).
- Emergency-Off situations. In an Emergency-Off situation, the main contactor is switched off (by the Emergency-Off button).

6.16.4 Safety instructions



WARNING

The drive cannot hold a vertical load when STO is active. Serious injury could result when load is not properly blocked. Drives with a suspended load must have an additional safe mechanical blocking (for instance, by a motor-holding brake).



CAUTION

The STO function does not provide an electrical separation from the power output. There is a danger of electrical shock and personnel injury! If access to the motor power terminals is necessary, the drive must be disconnected from mains supply considering the discharging time of the intermediate circuit.

NOTICE

If the safety function STO is automatically activated by a control system, then make sure that the output of the control is monitored for possible malfunction. The monitoring can be used to prevent a faulty output from unintentionally activating the STO function. Since the STO function is a single-channel system, erroneous engaging will not be recognized.

NOTICE

It is not possible to perform a controlled brake if the drive controlled STO-Enable is off. If controlled braking before the use of the STO function is necessary, the drive must be braked and the input STO must be separated time-delayed from +24 V .

NOTICE

Use the following functional sequence when the STO function is used:

1. Brake the drive in a controlled manner (speed setpoint = 0 V).
2. When speed = 0 rpm, disable the drive (enable = 0 V).
3. If a suspended load is present, block the drive mechanically.
4. Activate the STO function.

6.16.5 Technical data and pinning

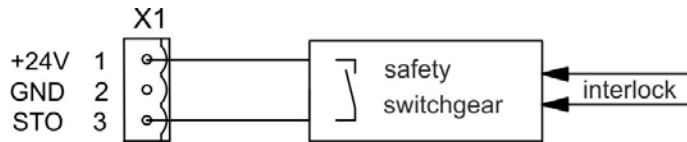

Pin	Signal	Description
1	+24	+24 VDC Auxiliary voltage
2	GND	24V Supply GND
3	STO	STO enable (Safe Torque Off)

6.16.6 Enclosure, wiring

Since the drive meets IP20, you must select an enclosure that permits safe operation of the drive. The enclosure must at least meet IP54 .

If you are wiring leads that are outside the specified enclosure (IP54), the cables must be laid durably (firmly), protected from outside damage (for example, by laying the cable in a duct), placed in different sheathed cables, or protected individually by grounding connection.

Wiring remaining within the specified enclosure must meet the requirements of the standard IEC 60204-1.

6.16.7 Functional description

When STO function (Safe Torque Off) is not needed, then the input STO must be connected directly with +24 V. The function is then bypassed and cannot be used. If the STO function is in use, then the input STO must be connected to the exit of a security control or a safety relay, which at least meets the requirements of PLd, CAT 3 according to ISO 13849 (connection diagram: → p. 56). Possible states of the drive referring to STO function:

STO	ENABLE	Display	Motor has Torque	Safety SIL 2
0 V	0 V	n602	no	yes
0 V	+24 V	F602	no	yes
+24 V	0 V	opmode	no	no
+24 V	+24 V	opmode with 'dot'	yes	no

When STO function is engaged during operation by separating input STO from 24 V, the motor slows down without control and the drive displays the fault F602.

It is not possible to perform a controlled brake if the drive STO-Enable is off.

If controlled braking before the use of the STO function is necessary, the drive must be braked and the input STO must be separated from +24 V time-delayed.

The STO function does not provide an electrical separation from the power output. If access to the motor power terminals is necessary, the drive must be disconnected from mains supply considering the discharging time of the intermediate circuit.

Since the STO function is a single-channel system, erroneous engaging will not be recognized. When wiring the input STO within one enclosure, the cables and the enclosure must meet the requirements of IEC 60204-1. If you are wiring leads outside the specified enclosure, then the cables must be laid durably and protected from outside damage.

6.16.7.1 Signal diagram (sequence)

The diagram below shows how to use STO function for a safe drive stop and fault free operation of the drive.

1. Brake the drive in a controlled manner (speed setpoint = 0 V).
2. When speed = 0 rpm, disable the drive (Enable = 0 V).
3. Activate the STO function (STO = 0 V)

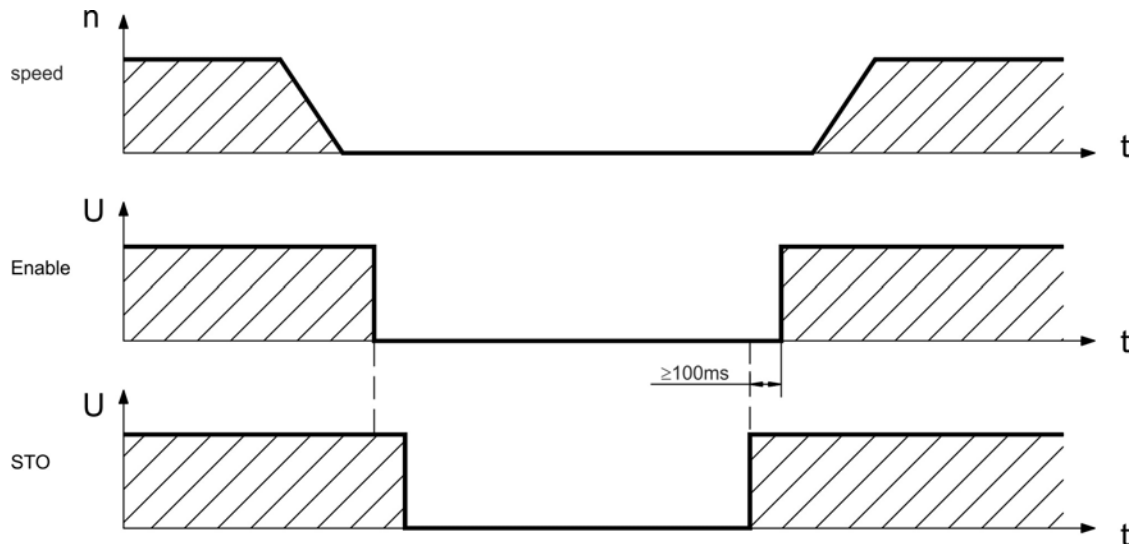

6.16.7.2 Functional test

NOTICE

You must test the STO function after initial start of the drive, after each interference into the wiring of the drive, or after exchange of one or several components of the drive.

First Method:

1. Stop drive, with setpoint 0 V. Keep drive enabled.
DANGER: Do not enter hazardous area!
2. Activate the STO function for example by opening protective screen (voltage at X1/3 0V).
3. The fault contact opens, the net contactor releases, and the drive displays fault F602.

Second Method:

1. Stop all drives, with setpoint 0 V, disable drive.
2. Activate the STO function, for example, by opening protective screen (voltage at X1/3 0V)
3. The drive displays warning n602.

6.16.7.3 Control circuit (example)

The example shows a control circuit with two separated work areas connected to one emergency stop circuit (mains supply circuit: → p. 57). For each work area, "safe stop" of the drives is switched by a protective screen. The safety switchgears used in the example are manufactured by Pilz and fulfill at least the PLd according to ISO 13849-1 or SIL CL2 according to IEC 62061. Safety switchgears from other manufacturers may also be used.

NOTE Review the wiring instructions; → p. 54.

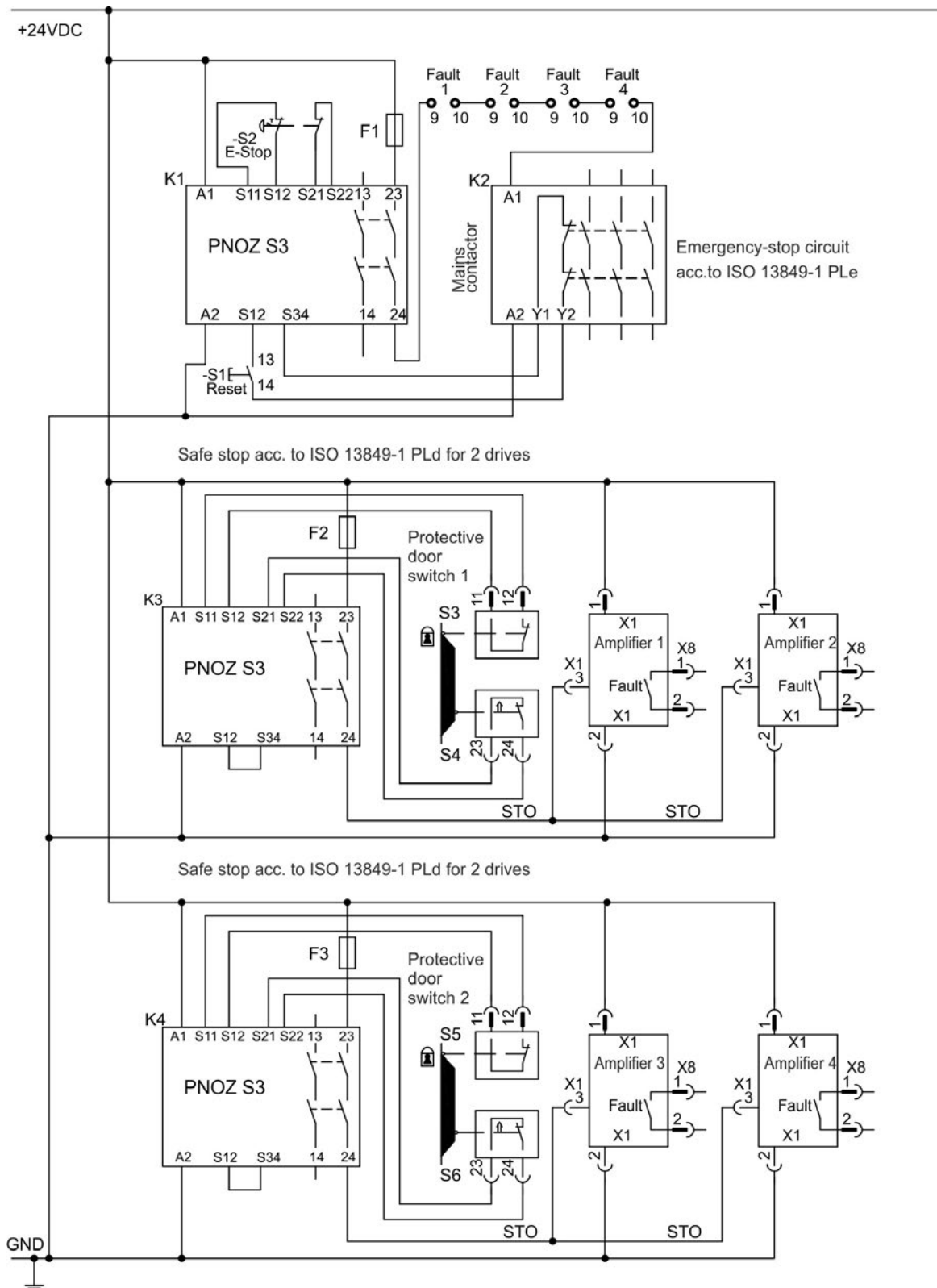

6.16.7.4 Mains supply circuit (example)

Corresponding control circuit → p. 56.

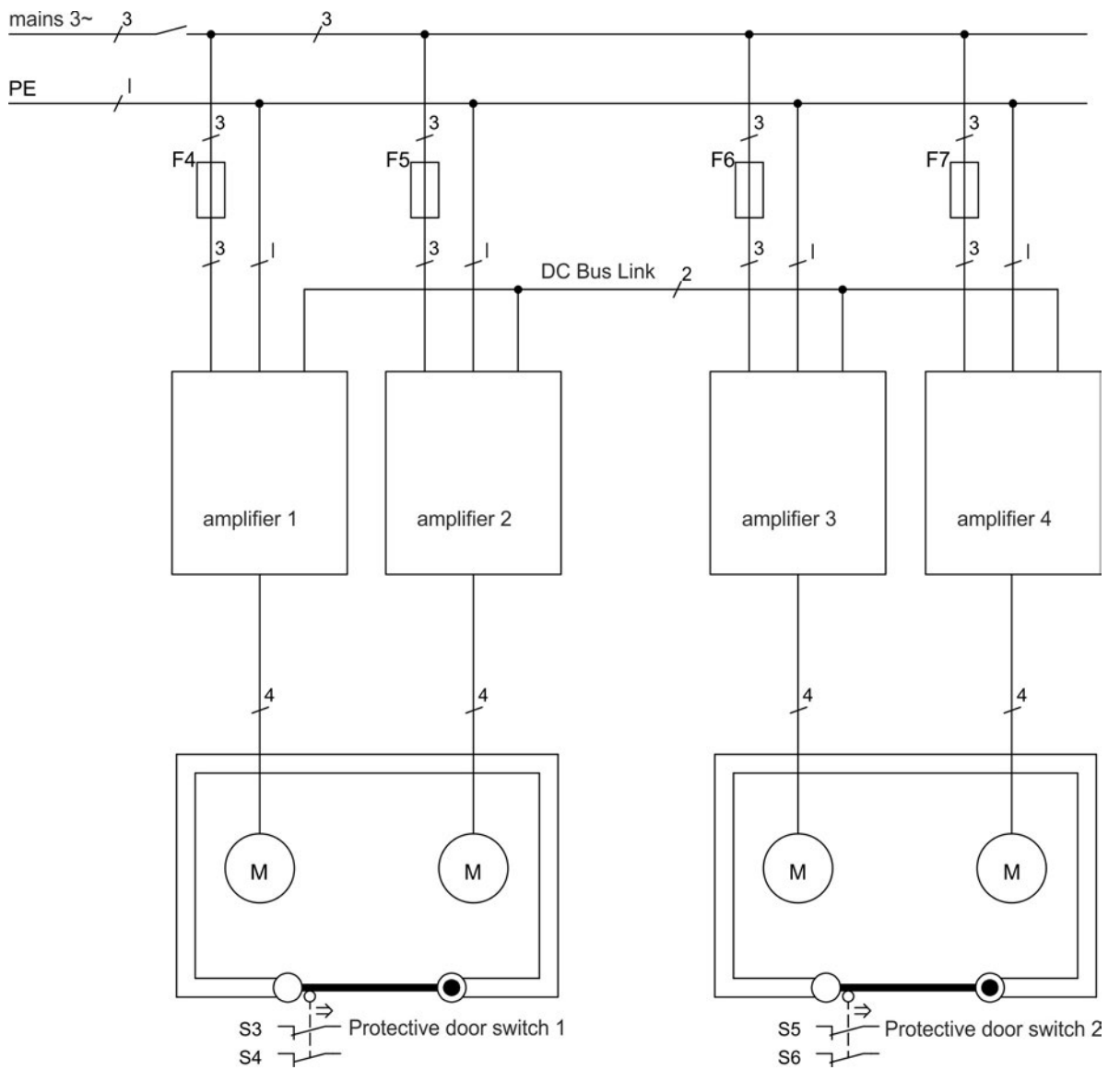

6.17 Shock-hazard Protection

6.17.1 Leakage current

Leakage current via the PE conductor results from the combination of equipment and cable leakage currents. The leakage current frequency pattern includes a number of frequencies, whereby the residual-current circuit breakers definitively evaluate the 50 Hz current. For this reason, the leakage current cannot be measured using a conventional multimeter.

As a rule of thumb, the following assumption can be made for leakage current on our low-capacity cables at a mains voltage of 400 V, depending on the clock frequency of the output stage:

$I_{\text{leak}} = n \times 20 \text{ mA} + L \times 1 \text{ mA/m}$ at 8 kHz clock frequency at the output stage

$I_{\text{leak}} = n \times 20 \text{ mA} + L \times 2 \text{ mA/m}$ at a 16 kHz clock frequency at the output stage

(where I_{leak} =leakage current, n =number of drives, L =length of motor cable)

At other mains voltage ratings, the leakage current varies in proportion to the voltage.

Example: 2 x drives + a 25m motor cable at a clock frequency of 8 kHz:

$2 \times 20 \text{ mA} + 25 \text{ m} \times 1 \text{ mA/m} = 65 \text{ mA}$ leakage current.

NOTE

Since the leakage current to PE is more than 3.5 mA, in compliance with IEC61800-5-1 the PE connection must either be doubled or a connecting cable with a cross-section $> 10 \text{ mm}^2$ must be used. Use the PE terminal and the PE connection screws in order to fulfill this requirement.

The following measures can be used to minimize leakage currents:

- Reduce the length of the engine cable.
- Use low-capacity cables (→ p. 39).

6.17.2 Residual current protective device (RCD)

In conformity with IEC 60364-4-41 – Regulations for installation and IEC 60204 – Electrical equipment of machinery, residual current protective devices (RCDs) can be used provided the requisite regulations are complied with.

The AKD is a 3-phase system with a B6 bridge. Therefore, RCDs which are sensitive to all currents must be used in order to detect any DC fault current. Refer to the chapter above for the rule of thumb for determining the leakage current.

Rated residual currents in the RCDs:

10 to 30 mA	Protection against "indirect contact" (personal fire protection) for stationary and mobile equipment, as well as for "direct contact".
50 to 300 mA	Protection against "indirect contact" (personal fire protection) for stationary equipment

NOTE

Recommendation: In order to protect against direct contact (with motor cables shorter than 5 m) Kollmorgen recommends that each drive be protected individually using a 30 mA RCD which is sensitive to all currents.

If you use a selective RCD, the more intelligent evaluation process will prevent spurious tripping of the RCD.

6.17.3 Isolating transformers

When protection against indirect contact is absolutely essential despite a higher leakage current, or when an alternative form of shock-hazard protection is sought, the AKD can also be operated via an isolating transformer (schematic connection → p. 89).

A ground-leakage monitor can be used to monitor for short circuits.

NOTE

Keep the length of wiring between the transformer and the drive as short as possible.

7 Mechanical Installation

7.1 Important Notes	60
7.2 Guide to Mechanical Installation	60
7.3 Mechanical Drawings Standard Width	61
7.4 Mechanical Drawings Extended Width	65

7.1 Important Notes



CAUTION

There is a danger of electrical shock by high EMC level which could result in injury, if the drive (or the motor) is not properly EMC-grounded. Do not use painted (i.e. non-conductive) mounting plates.

NOTICE

Protect the drive from impermissible stresses. In particular, do not let any components become bent or any insulation distances altered during transport and handling. Avoid contact with electronic components and contacts.

NOTICE

The drive will switch itself off in case of overheating. Ensure that there is an adequate flow of cool, filtered air into the bottom of the control cabinet, or use a heat exchanger ("Ambient Conditions, Ventilation, and Mounting Position" (→ p. 32)).

NOTICE

Do not mount devices that produce magnetic fields directly beside the drive. Strong magnetic fields can directly affect internal components. Install devices which produce magnetic field with distance to the drives and/or shield the magnetic fields.

7.2 Guide to Mechanical Installation

The following tools are required (at a minimum) to install the AKD; your specific installation may require additional tools:

- M4 hexagon socket-cap screws (ISO 4762)
- 3 mm T-handle Allen key
- No. 2 Phillips head screwdriver
- Small slotted screwdriver

Dimensions and mounting hole positions depend on the drive variant:

Drive Variant	Description	Housing
AKD-B, -P, -T	Drives without built-in option card	Standard width, → p. 61
AKD-B-IC, -T-IC, -M-MC	Drives with built-in option card (for example I/O, MC)	Extended width, → p. 65

Install the drive unit as follows:

1. Prepare the site.
Mount the drive in a closed control cabinet (→ p. 32). The site must be free from conductive or corrosive materials. For the mounting position in the cabinet → p. 61ff respectively → p. 65ff.
2. Check ventilation.
Check that the ventilation of the drive is unimpeded, and keep within the permitted ambient temperature → p. 32. Keep the required space clearance above and below the drive → p. 61ff respectively → p. 65ff.
3. Check cooling system.
If cooling systems are used for the control cabinet, position the cooling system so that condensation water cannot drip onto the drive or peripheral devices.
4. Mount the drive.
Assemble the drive and power supply near each other on the conductive, grounded mounting plate in the cabinet.
5. Ground the drive.
For EMC-compliant shielding and grounding, → p. 85. Ground the mounting plate, motor housing and CNC-GND of the control system.

7.3 Mechanical Drawings Standard Width

7.3.1 Control cabinet layout AKD-xzzz06, standard width

Material: M4 hexagon socket screws to ISO 4762, 3 mm T-handle Allen key

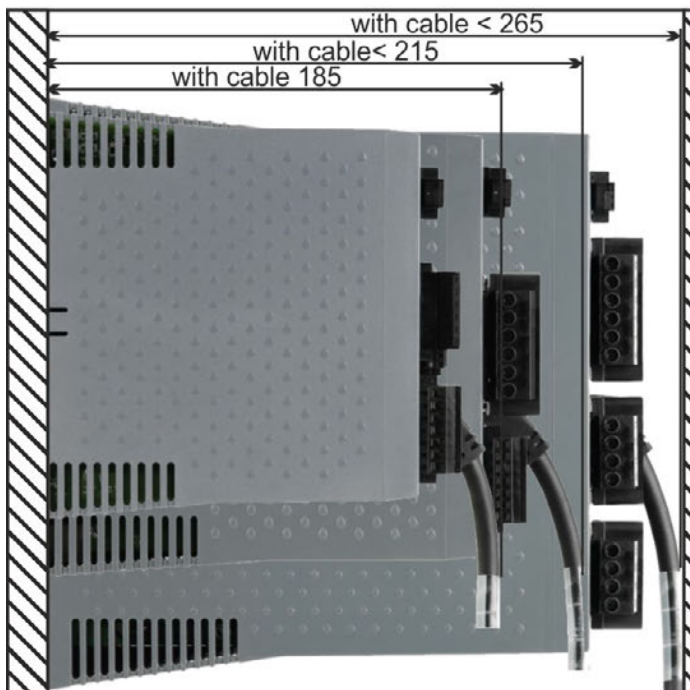
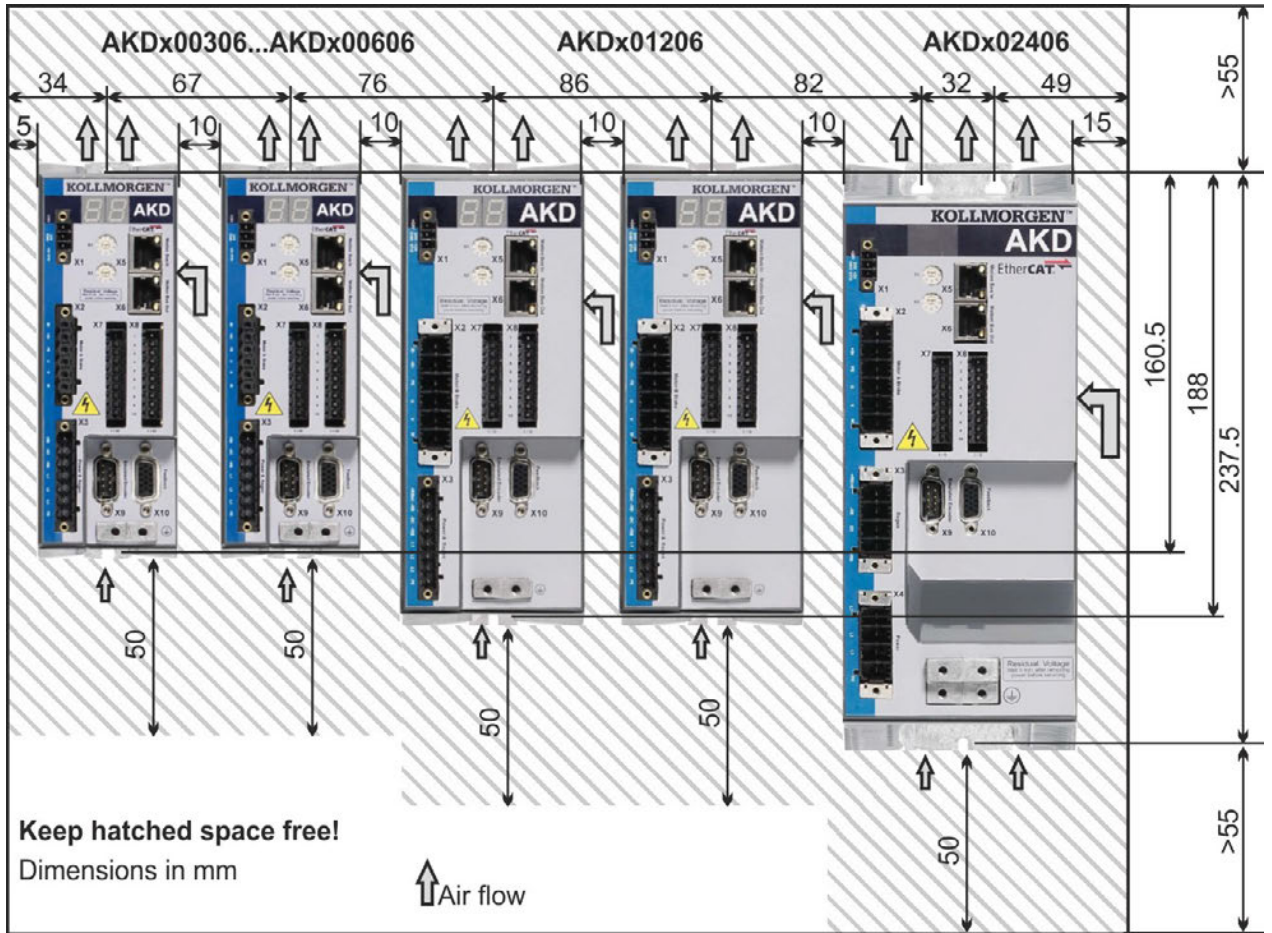

7.3.2 Control cabinet layout AKD-xzzz07, standard width

Material: M4 hexagon socket screws to ISO 4762, 3 mm T-handle Allen key

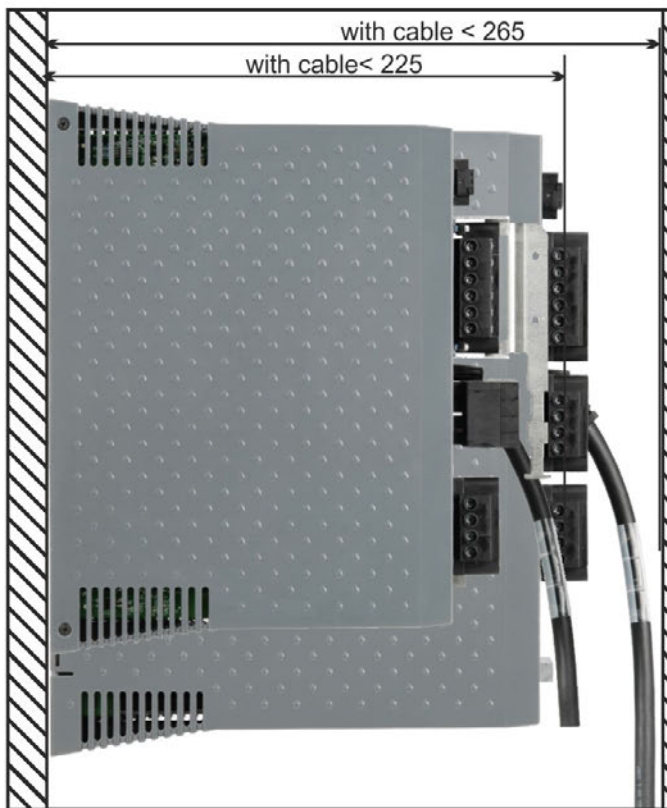
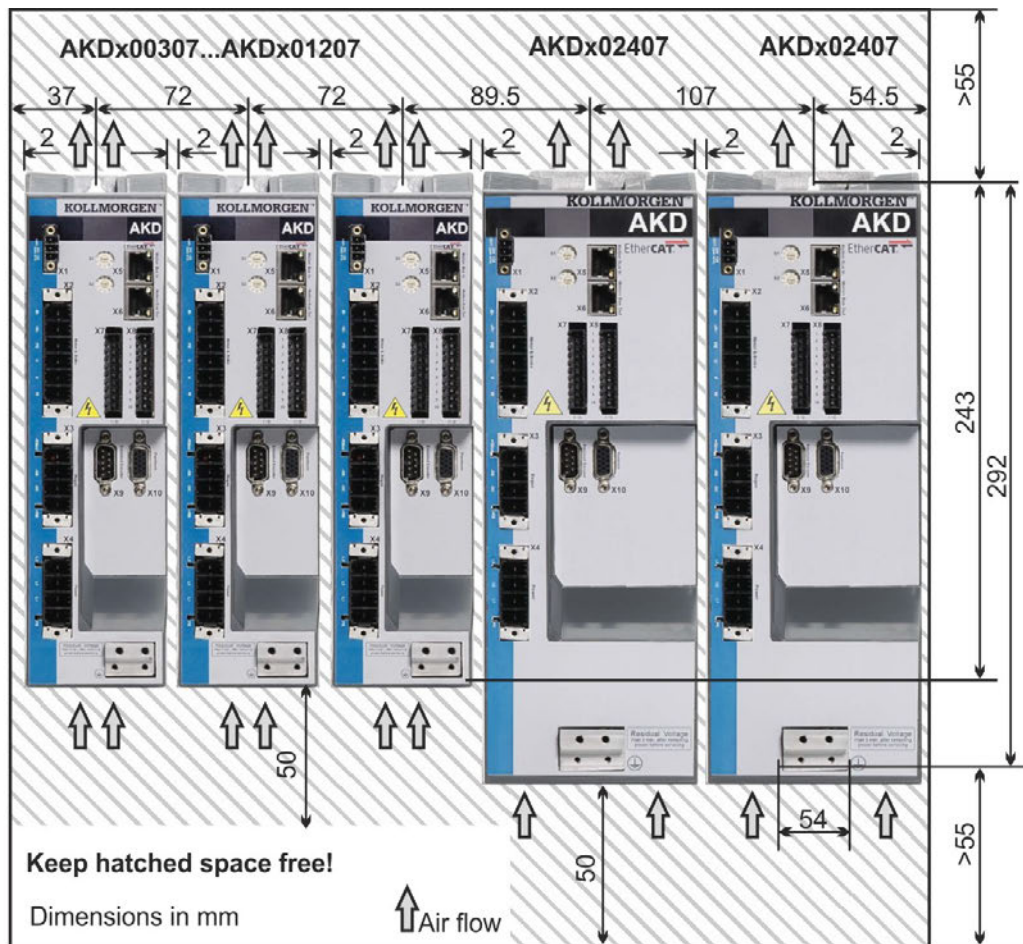

7.3.3 Dimensions AKD-xzzz06, standard width

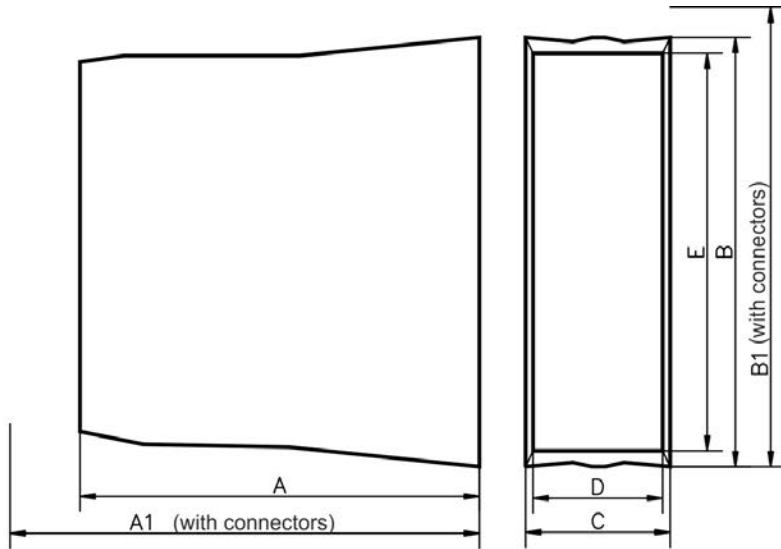

Standard Width 110 - 230V	A	A1	B	B1	C	D	E
	mm	mm	mm	mm	mm	mm	mm
AKD 3A, 6A	156	185	168	200	59	54	150
AKD 12A	187	215	196	225	78.4	72	177
AKD 24A	228	265	248	280	100	96	217

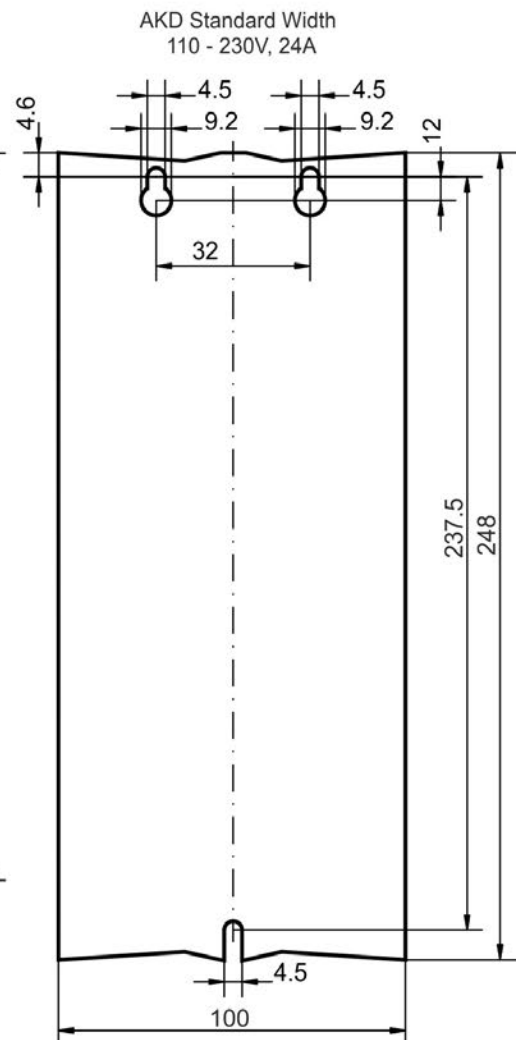
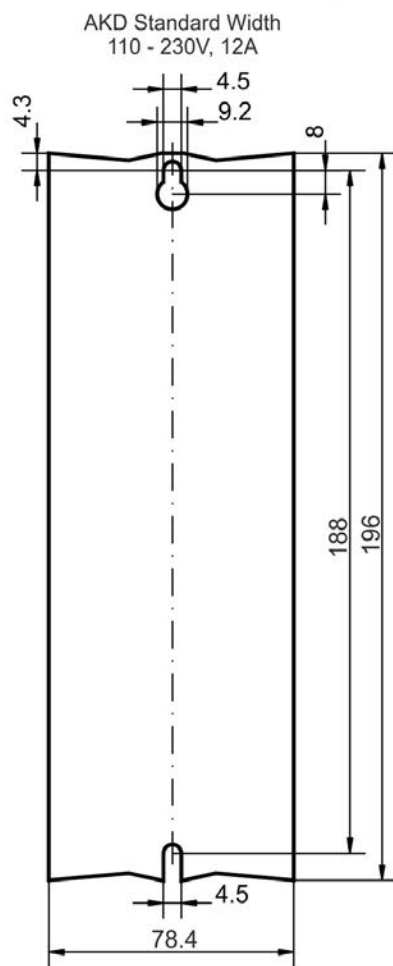
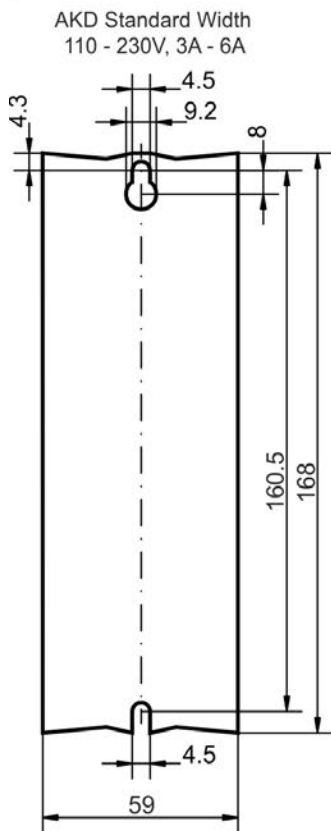

7.3.4 Dimensions AKD-xzzz07, standard width

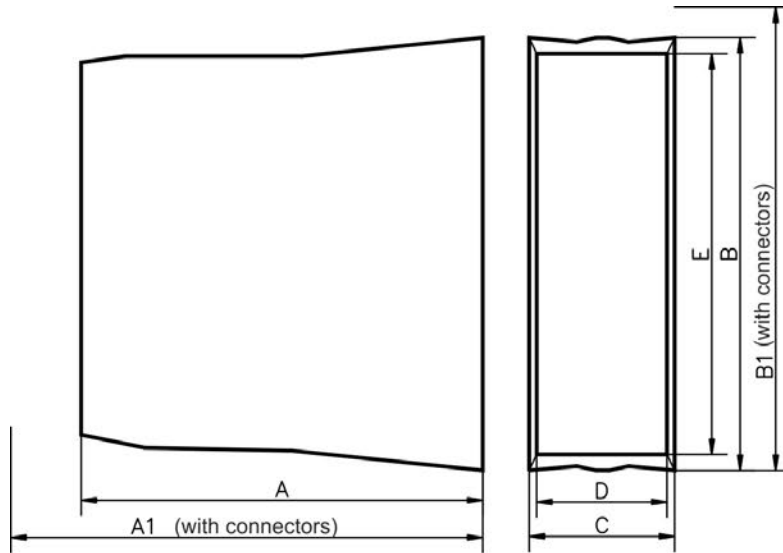

Standard Width 480V	A	A1	B	B1	C	D	E
	mm	mm	mm	mm	mm	mm	mm
AKD 3A, 6A, 12A	185	221	256	290	70	65	232
AKD 24A	228	264	306	340	105	99	273

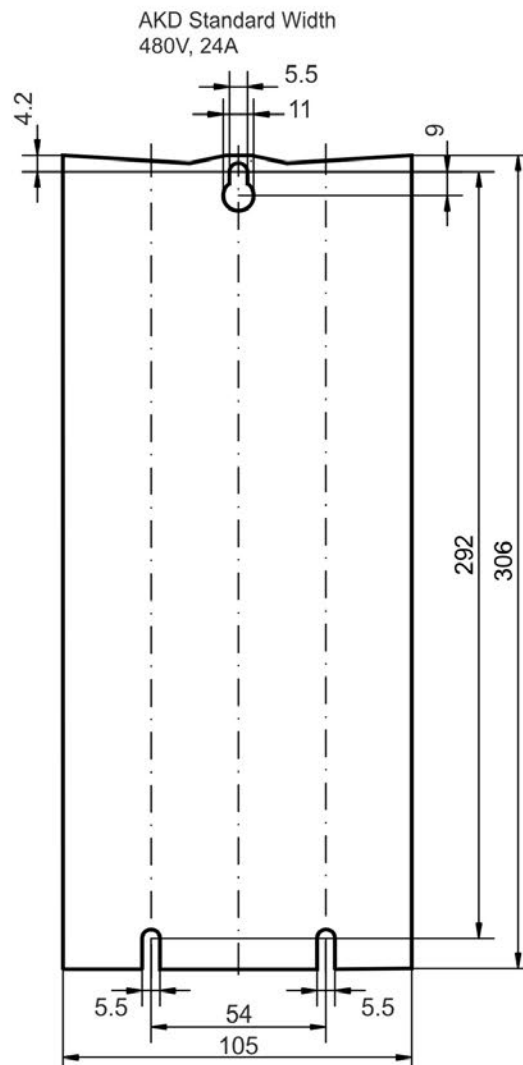
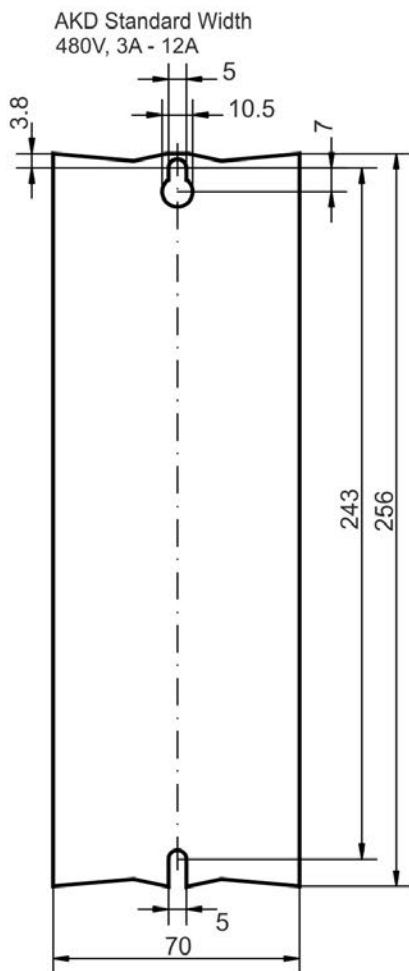

7.4 Mechanical Drawings Extended Width

7.4.1 Control cabinet layout, example with AKD-M00306

Material: M4 hexagon socket screws to ISO 4762, 3 mm T-handle Allen key

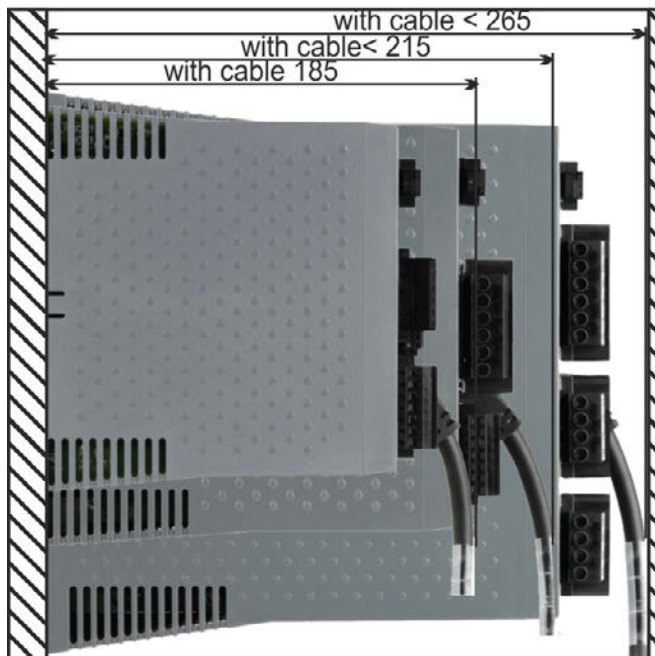
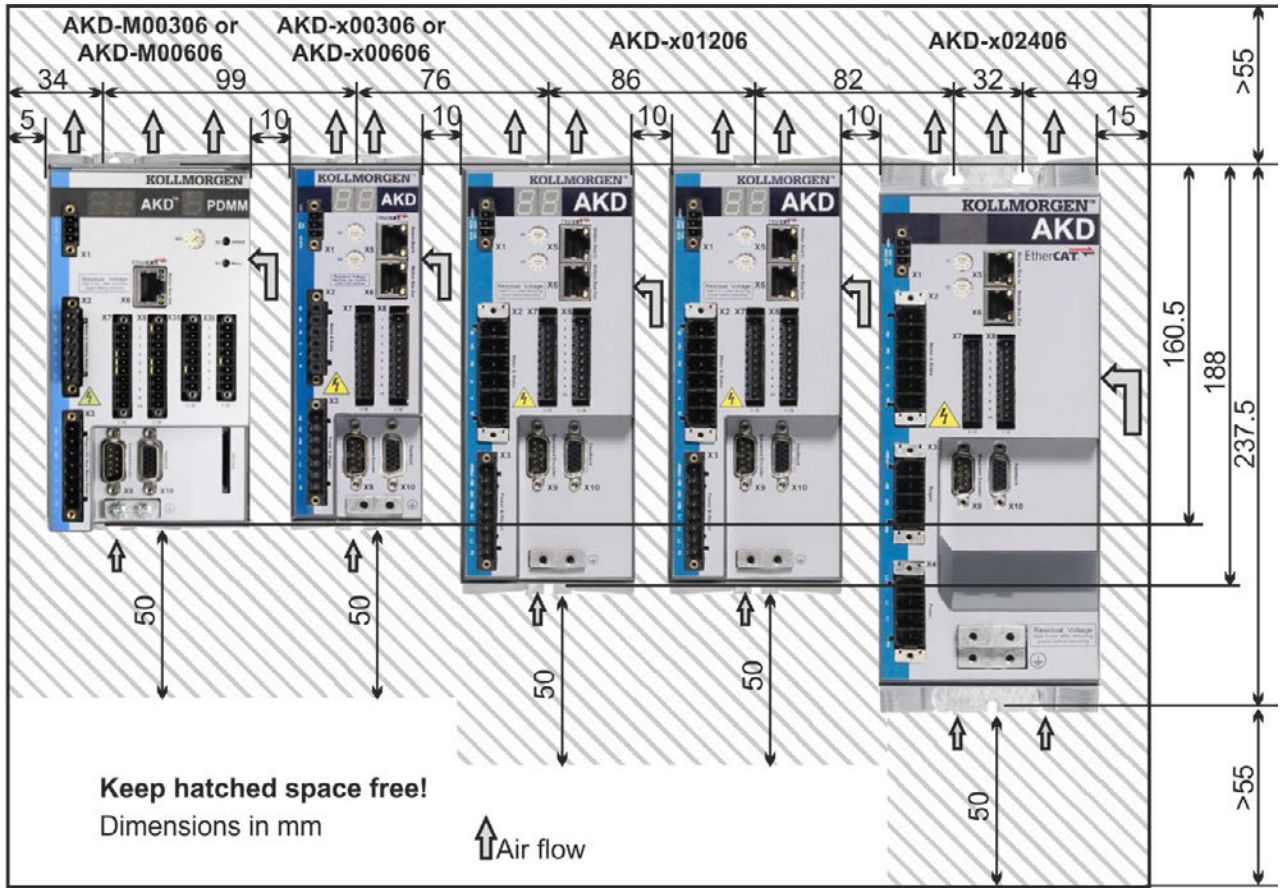

7.4.2 Control cabinet layout, example with AKD-M00307

Material: M4 hexagon socket screws to ISO 4762, 3 mm T-handle Allen key

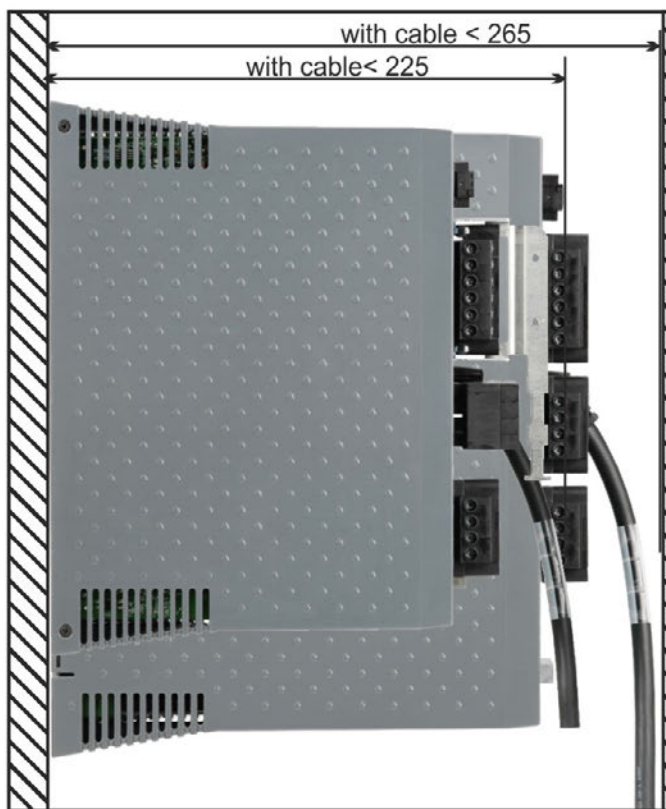
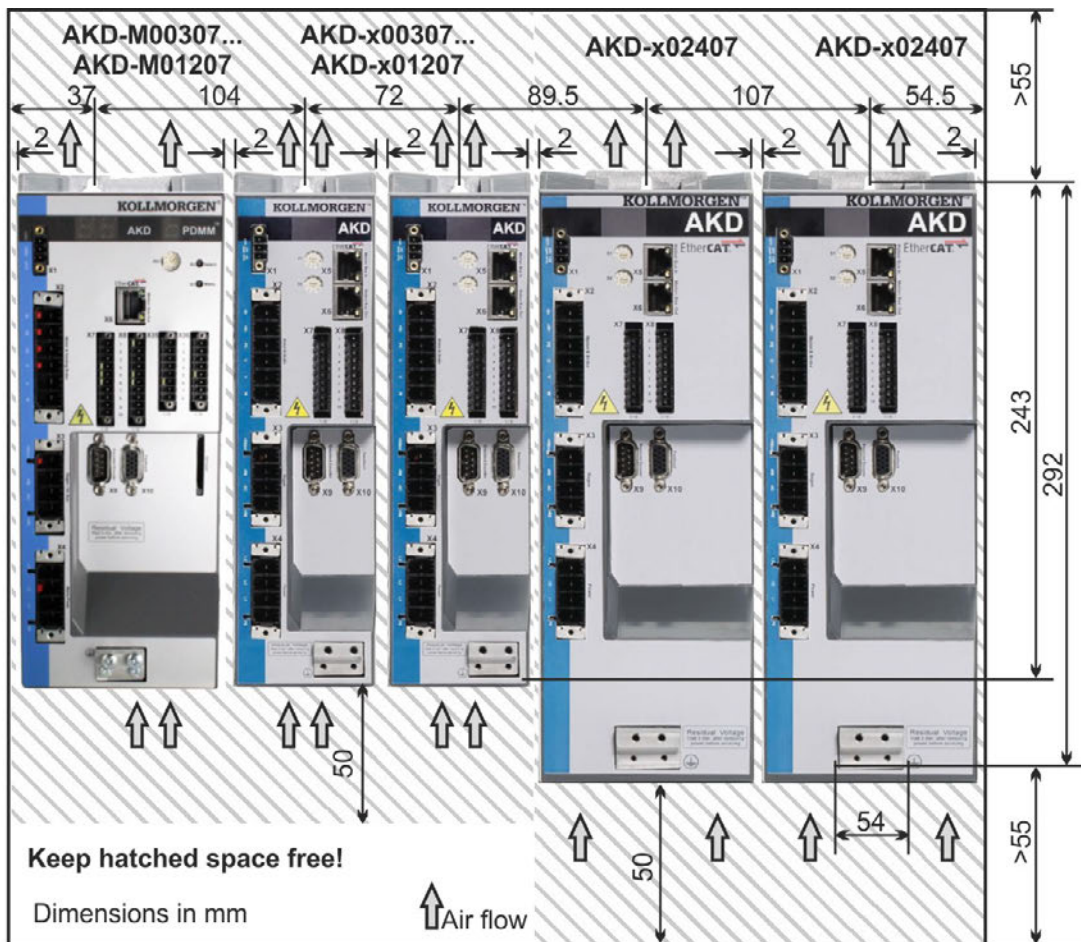

7.4.3 Dimensions AKD-xzzz06, extended width

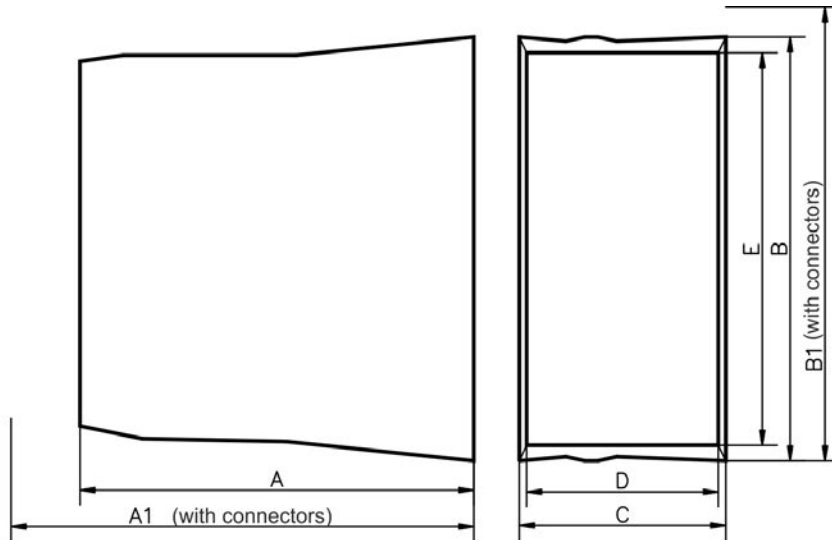

Extended Width 110 to 230V	A	A1	B	B1	C	D	E
	mm	mm	mm	mm	mm	mm	mm
AKD 3A, 6A	156	185	168	200	89	84	150
AKD 12A	187	215	196	225	96	91	177
AKD 24A	228	258	248	278	100	96	217

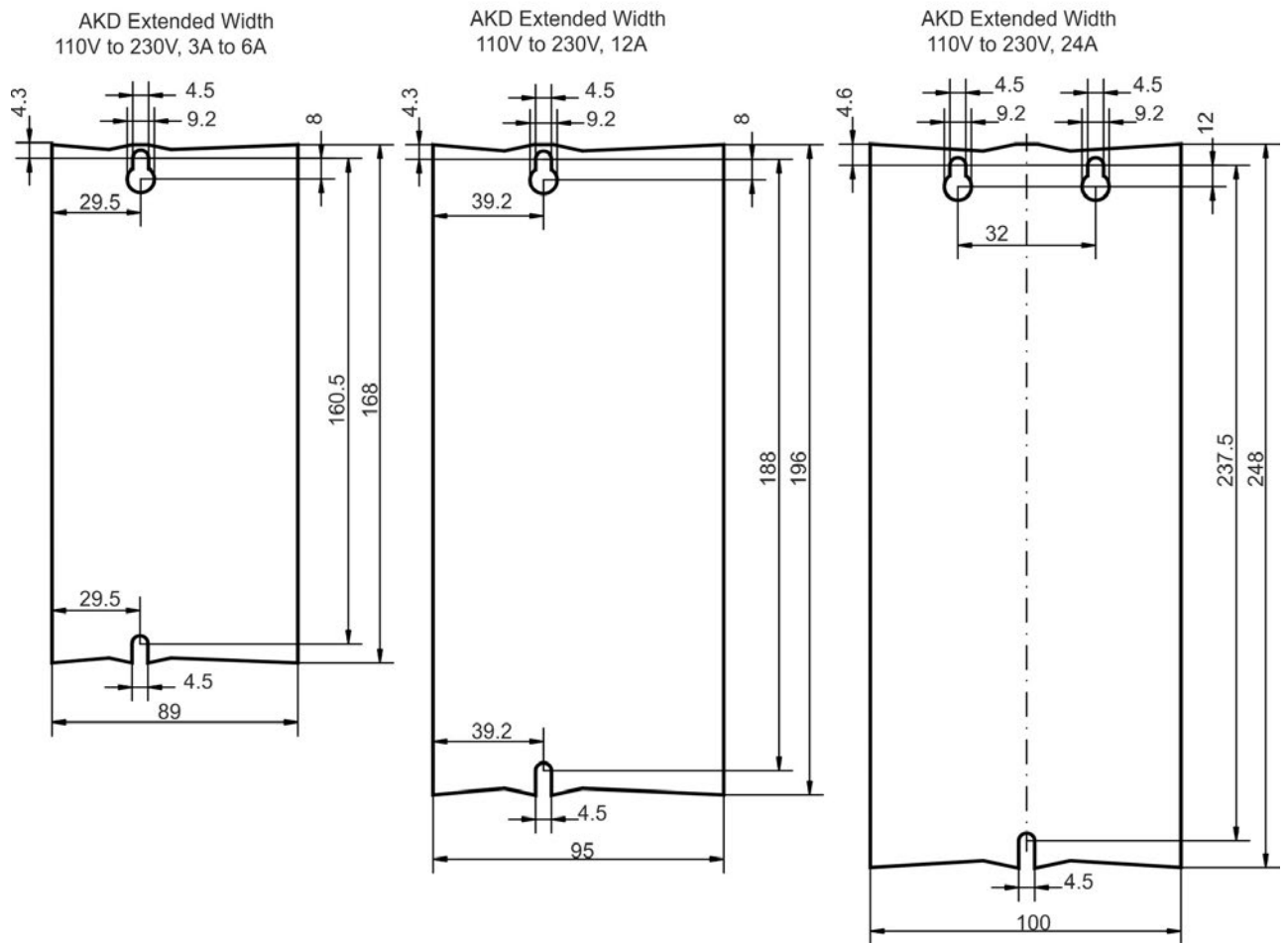

7.4.4 Dimensions AKD-xzzz07, extended width

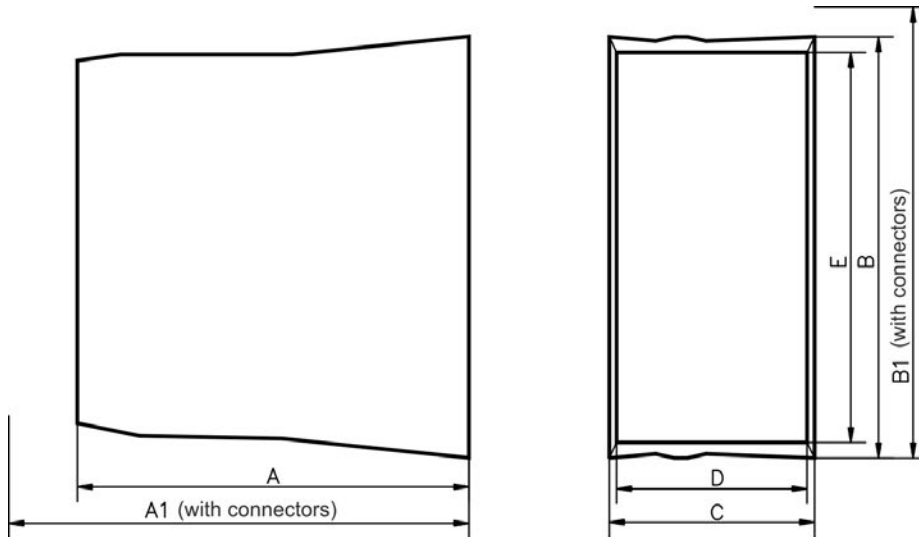

Extended Width 480V	A	A1	B	B1	C	D	E
	mm	mm	mm	mm	mm	mm	mm
AKD 3A, 6A, 12A	185	221	256	290	100	95	232
AKD 24A	228	264	306	340	105	99	273

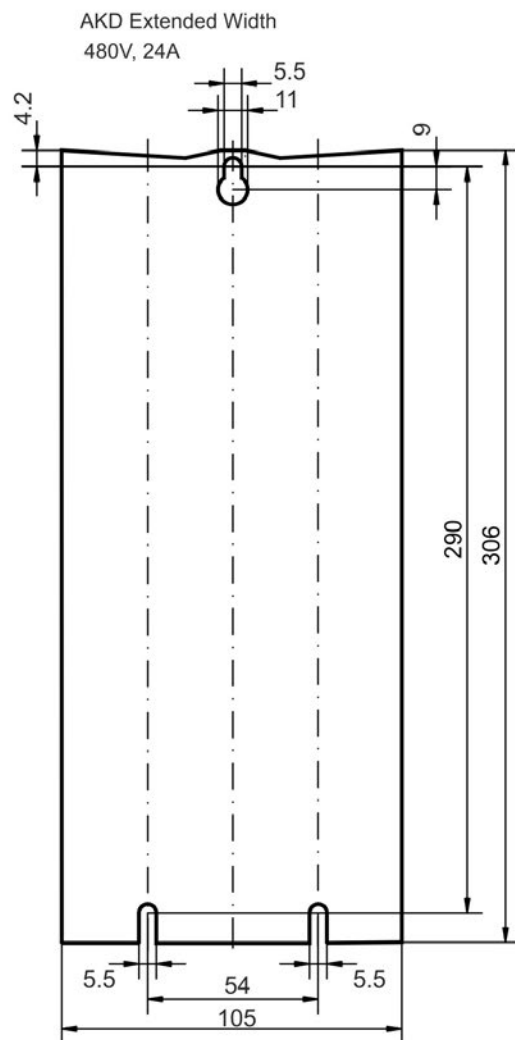
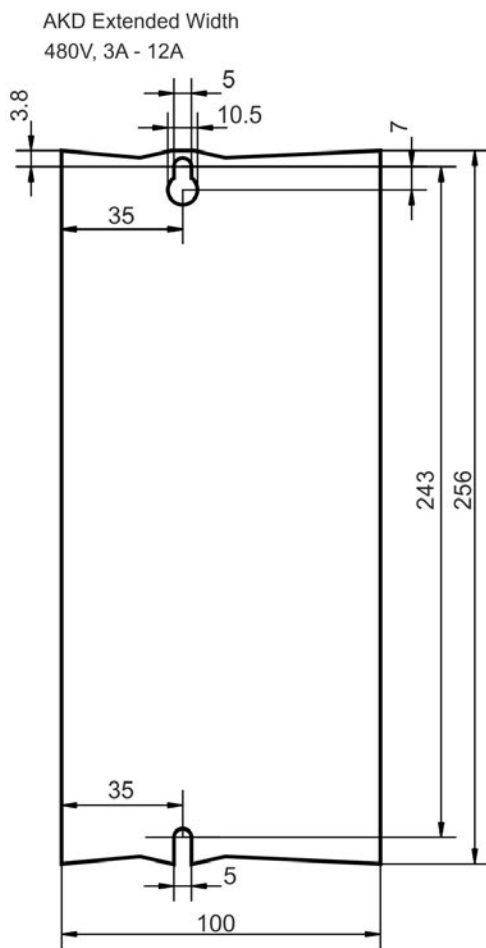

8 Electrical Installation

8.1	Important Notes	70
8.2	Guide to electrical installation	71
8.3	Wiring	72
8.4	Components of a servosystem	73
8.5	Connection Overview AKD-B, AKD-P, AKD-T	75
8.6	Connection Overview AKD-M	80
8.7	EMI Noise Reduction	85
8.8	Electrical Supply Connection	89
8.9	DC Bus link (X3)	94
8.10	Motor Connection	100
8.11	Feedback Connection	103
8.12	Electronic gearing, Master-slave operation	117
8.13	I/O Connection	125
8.14	LED display	143
8.15	Rotary Switches (S1, S2, RS1)	144
8.16	Pushbuttons (B1, B2, B3)	145
8.17	SD Card Slot	147
8.18	Service Interface (X11, X32)	149
8.19	CAN-Bus Interface (X12/X13)	153
8.20	Motion Bus Interface (X5/X6/X11)	158

8.1 Important Notes



DANGER

Never remove electrical connections to the drive while it is live. There is a danger of electrical arcing with damage to contacts and serious personal injury. Wait at least seven minutes after disconnecting the drive from the main supply power before touching potentially live sections of the equipment (e.g. contacts) or undoing any connections.

Capacitors can still have dangerous voltages present up to 7 minutes after switching off the supply power. To be sure, measure the voltage in the DC bus link and wait until it has fallen below 60 V.

Control and power connections can still be live, even if the motor is not rotating.

NOTICE

Wrong mains voltage, unsuitable motor or wrong wiring will damage the drive. Check the combination of drive and motor. Compare the rated voltage and current of the units. Implement the wiring according to the connection diagram : → p. 77.

Make sure that the maximum permissible rated voltage at the terminals L1, L2, L3 or +DC, – DC is not exceeded by more than 10% even in the most unfavorable circumstances (see IEC 60204-1).

NOTICE

Excessively high external fusing will endanger cables and devices. The fusing of the AC supply input and 24 V supply must be installed by the user, best values → p. 37. Hints for use of Residual-current circuit breakers (RCD) → p. 58.

NOTICE

The drive status must be monitored by the PLC to acknowledge critical situations. Wire the FAULT contact in series into the emergency stop circuit of the installation. The emergency stop circuit must operate the supply contactor.

NOTE

It is permissible to use the setup software to alter the settings of the drive. Any other alterations will invalidate the warranty.

8.2 Guide to electrical installation

Install the drive electrical system as follows:

1. Select cables in accordance with IEC 60204 → p. 39.
2. Install shielding and ground the drive.
For EMC-compliant shielding and grounding, see → p. 85 → p. 77 ff.
Ground the mounting plate, motor housing and CNC-GND of the control system.
3. Wire the drive and connectors.
Observe the "Recommendations for EMI noise reduction": → p. 85
 - Wire the FAULT contact in series into the emergency stop circuit of the system.
 - Connect the digital control inputs and outputs.
 - Connect up analog ground (also if fieldbuses are used).
 - Connect the analog input source, if required.
 - Connect the feedback device.
 - Connect the hardware option.
 - Connect the motor cable
 - Connect shielding at both ends. Use a motor choke if cable > 25m.
 - Connect motor-holding brake, connect shielding at both ends.
 - If required, connect the external regen resistor (with fusing).
 - Connect the auxiliary supply (maximum permissible voltage values see electrical data (→ p. 34 or → p. 35).
 - Connect the mains filter with AKD-xzzz06 (shielded lines between filter and drive).
 - Connect the main electrical supply.
Check maximum permitted voltage value (→ p. 34 or → p. 35).
 - Check proper use of residual-current circuit breakers (RCD): → p. 58
 - Connect the PC (→ p. 149) for setting up the drive.
4. Check the wiring against the wiring diagrams.

8.3 Wiring

The installation procedure is described as an example. A different procedure may be appropriate or necessary, depending on the application of the equipment. Kollmorgen can provide training courses for this procedure upon request.



DANGER

There is a danger of electrical arcing which can cause serious personnel injury. Only install and wire the equipment when it is not live, that is, when neither the electrical supply nor the 24 V auxiliary voltage nor the supply voltages of any other connected equipment is switched on.

Make sure that the cabinet is safely disconnected (for instance, with a lock-out and warning signs). The individual voltages are switched on for the first time during setup.

NOTICE

Only professional staff who are qualified in electrical engineering are allowed to install the drive. Wires with color green with one or more yellow stripes must not be used other than for protective earth (PE) wiring.

NOTE

The ground symbol, which you will find in all the wiring diagrams, indicates that you must take care to provide an electrically conductive connection with the largest feasible surface area between the unit indicated and the mounting plate in the control cabinet. This connection is for the effective grounding of HF interference, and must not be confused with the PE-symbol (PE = protective earth, safety measure as per IEC 60204).

Use the following connection diagrams:

Overview (all connections):

- AKD-B/P/T variant	→ p. 77 ff
- AKD-M variant	→ p. 82 ff
Shielding:	→ p. 85
Mains power:	→ p. 92
DC Bus Link:	→ p. 94
Motor:	→ p. 100
Feedback:	→ p. 103
Electronic gearing:	→ p. 117
Encoder emulation:	→ p. 119
Digital and analog inputs and outputs:	→ p. 125
Service interface:	→ p. 149
CAN-Bus interface:	→ p. 153
Motion bus interface	→ p. 158

8.4 Components of a servosystem

With AKD-xzzz06

NOTE

Cables drawn bold are shielded. Electrical ground is drawn with dash-dotted lines. Optional devices are connected with dashed lines to the drive. The required accessories are described in the accessories manual.

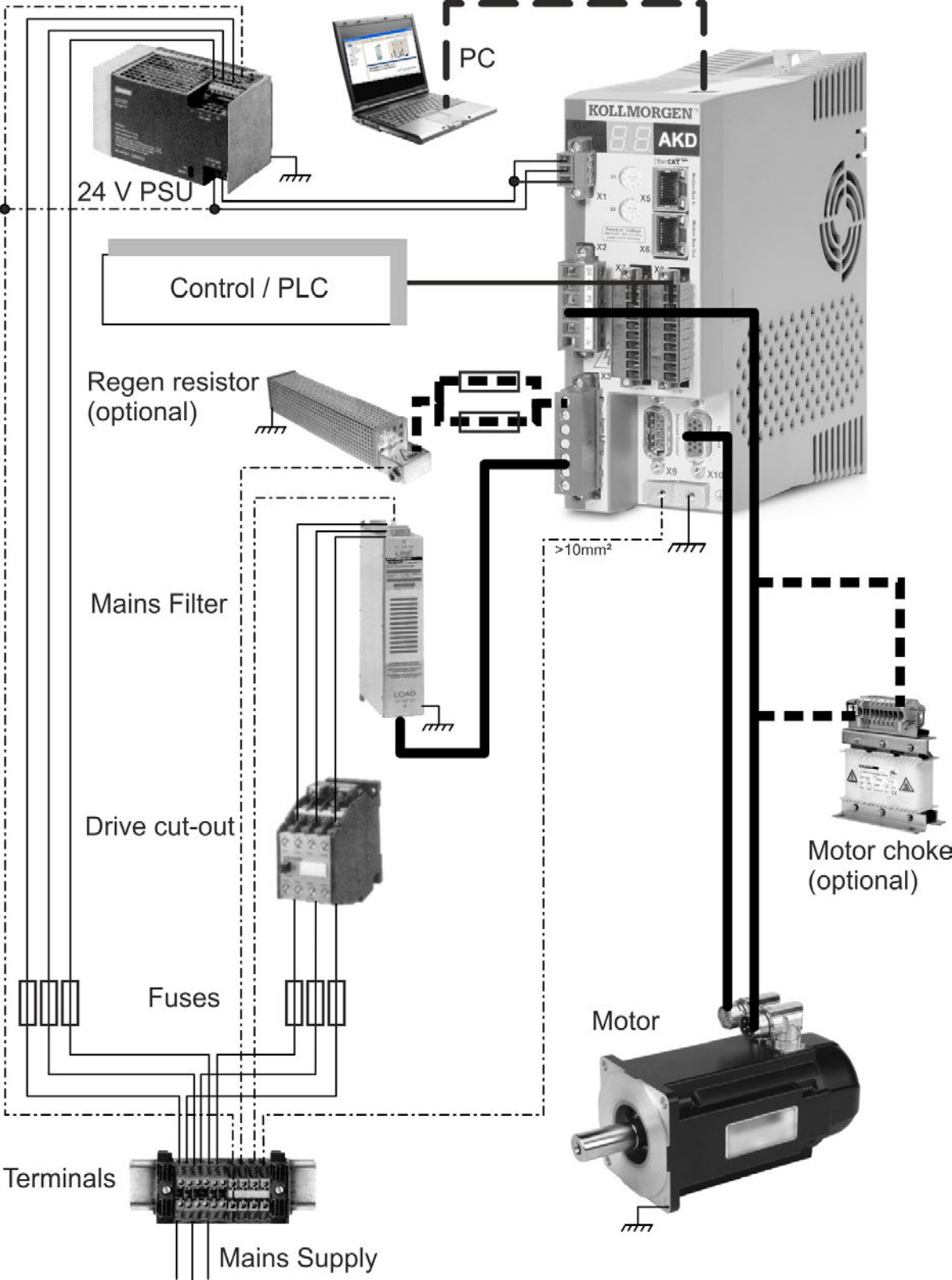

With AKD-xzzz07

NOTE

Cables drawn bold are shielded. Electrical ground is drawn with dash-dotted lines. Optional devices are connected with dashed lines to the drive. The required accessories are described in the accessories manual.

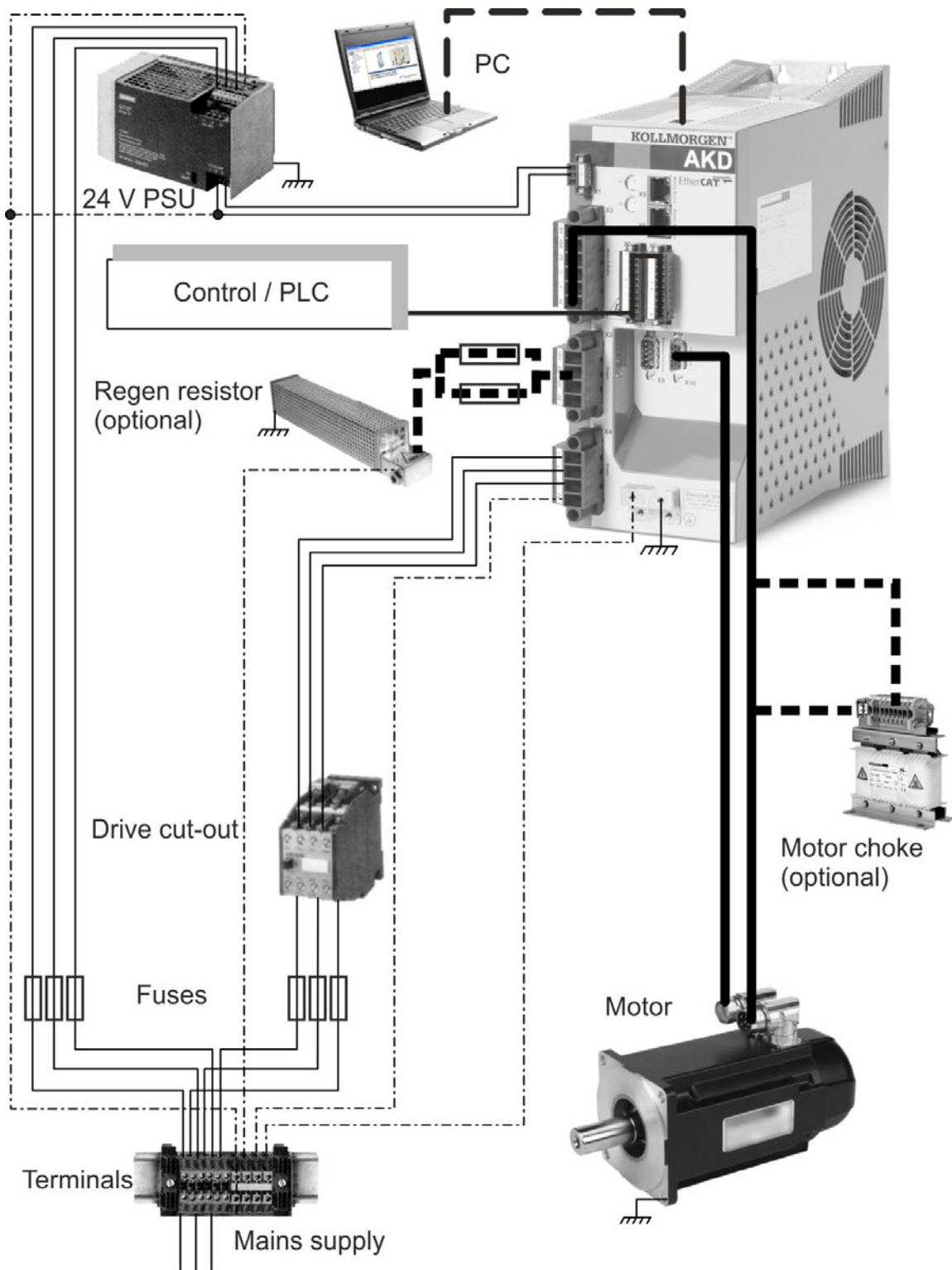

8.5 Connection Overview AKD-B, AKD-P, AKD-T

8.5.1 Connector assignment AKD-x00306, AKD-x00606

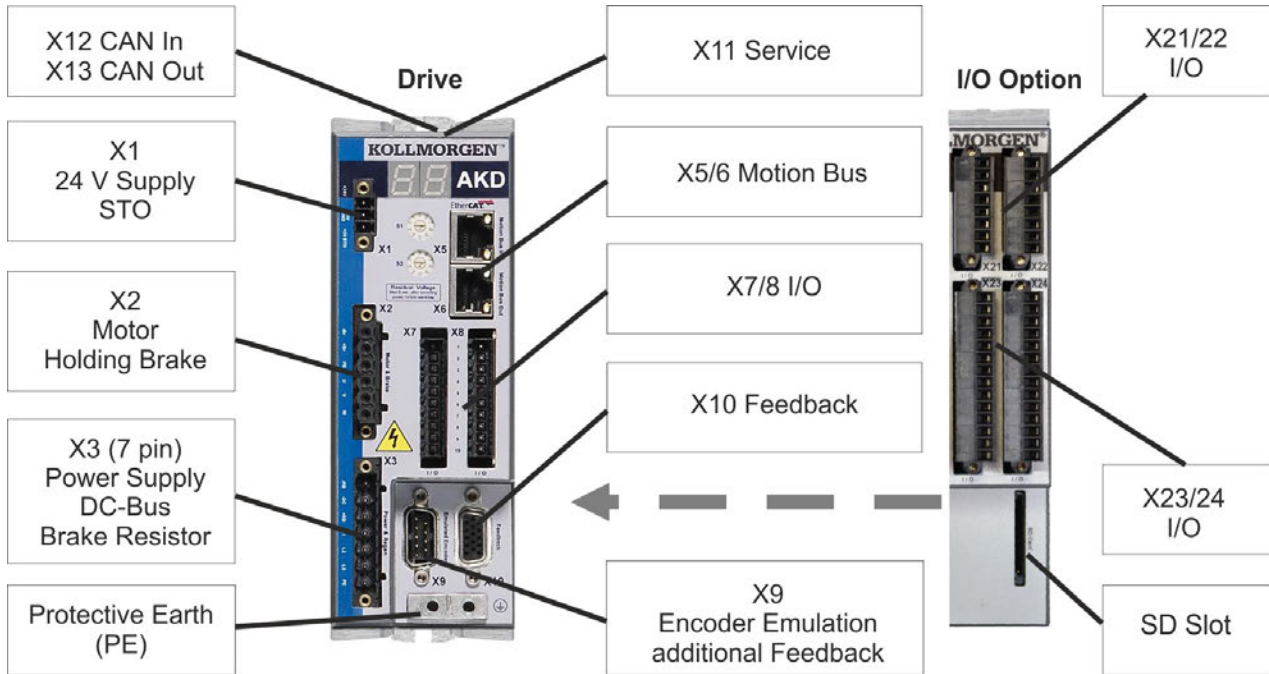

The I/O option is available for AKD-T drives only.

8.5.2 Connector assignment AKD-x01206

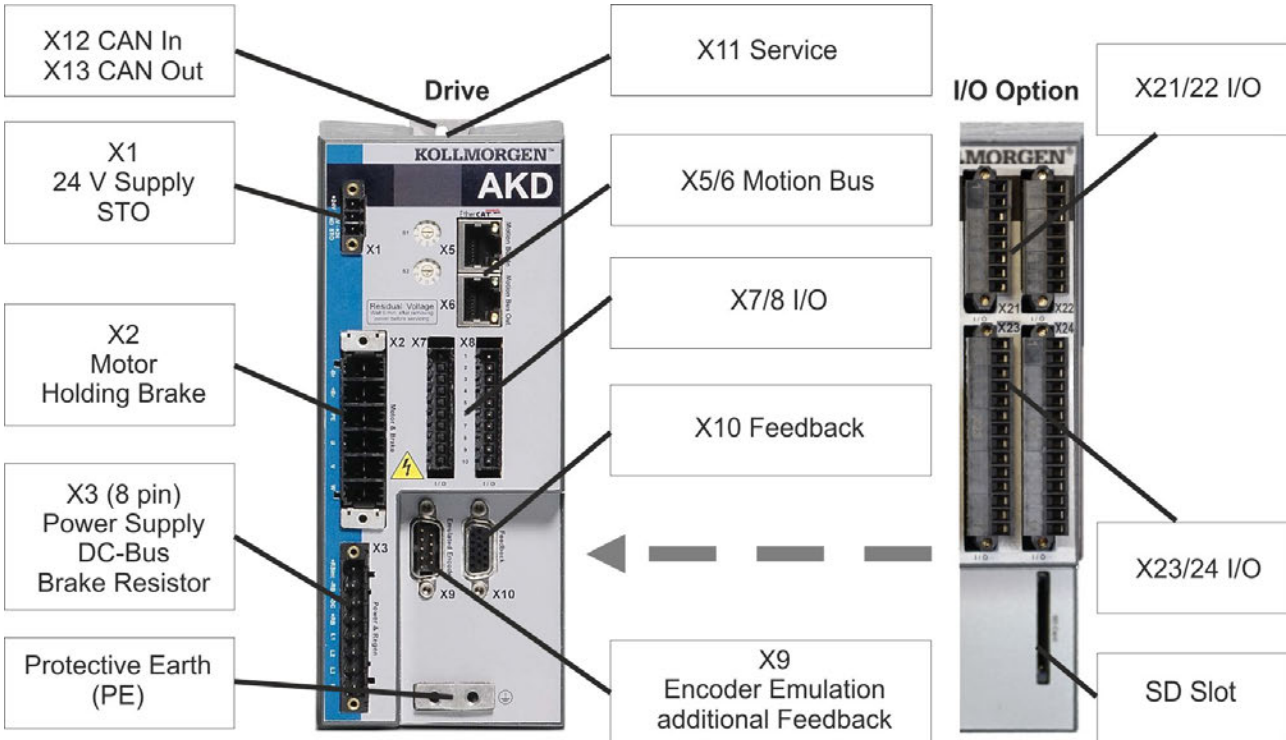

The I/O option is available for AKD-T drives only.

8.5.3 Connector assignment AKD-x02406 and AKD-xzzz07

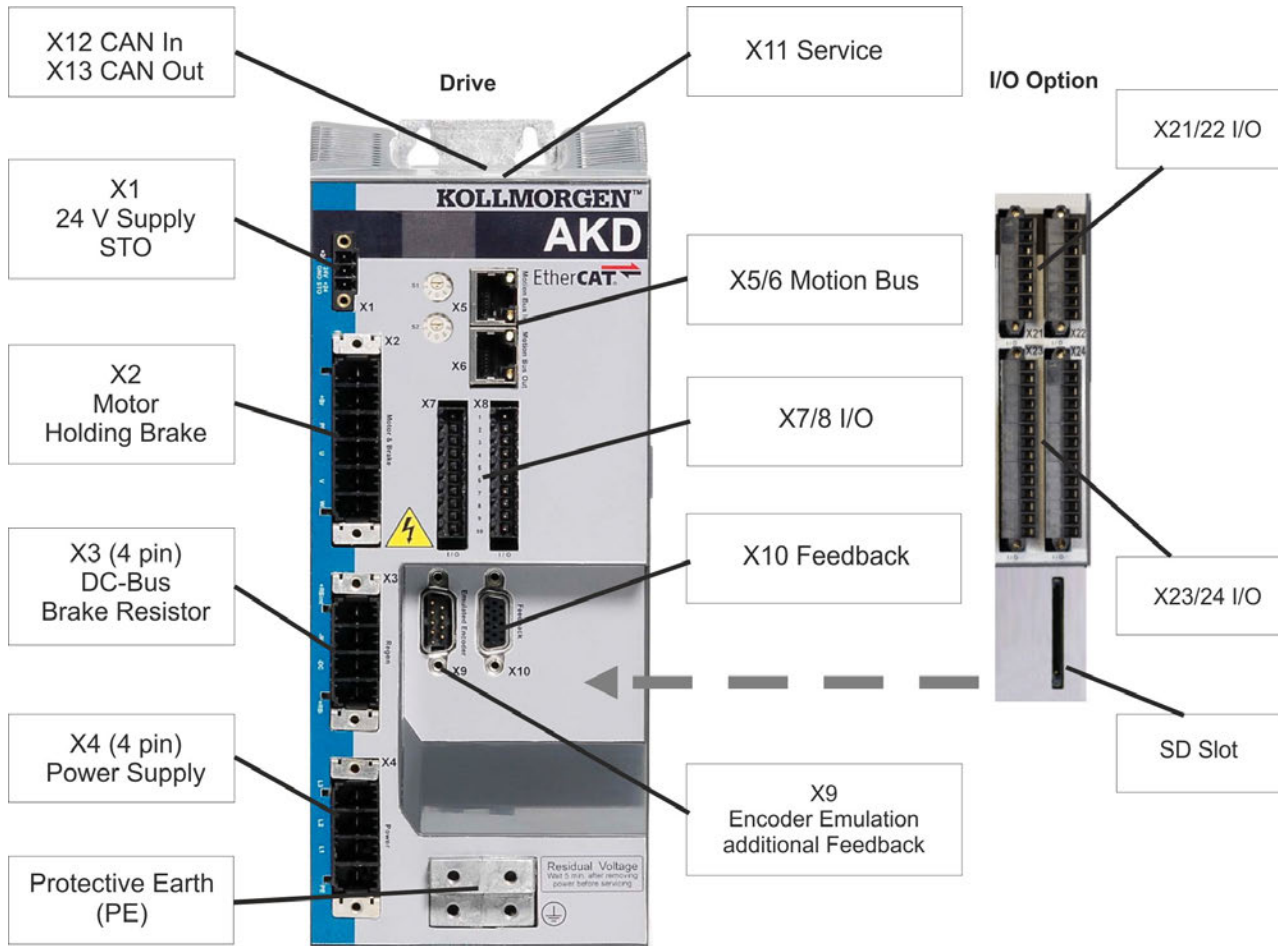

The I/O option is available for AKD-T drives only.

8.5.4 Connection diagram AKD-x00306, AKD-x00606

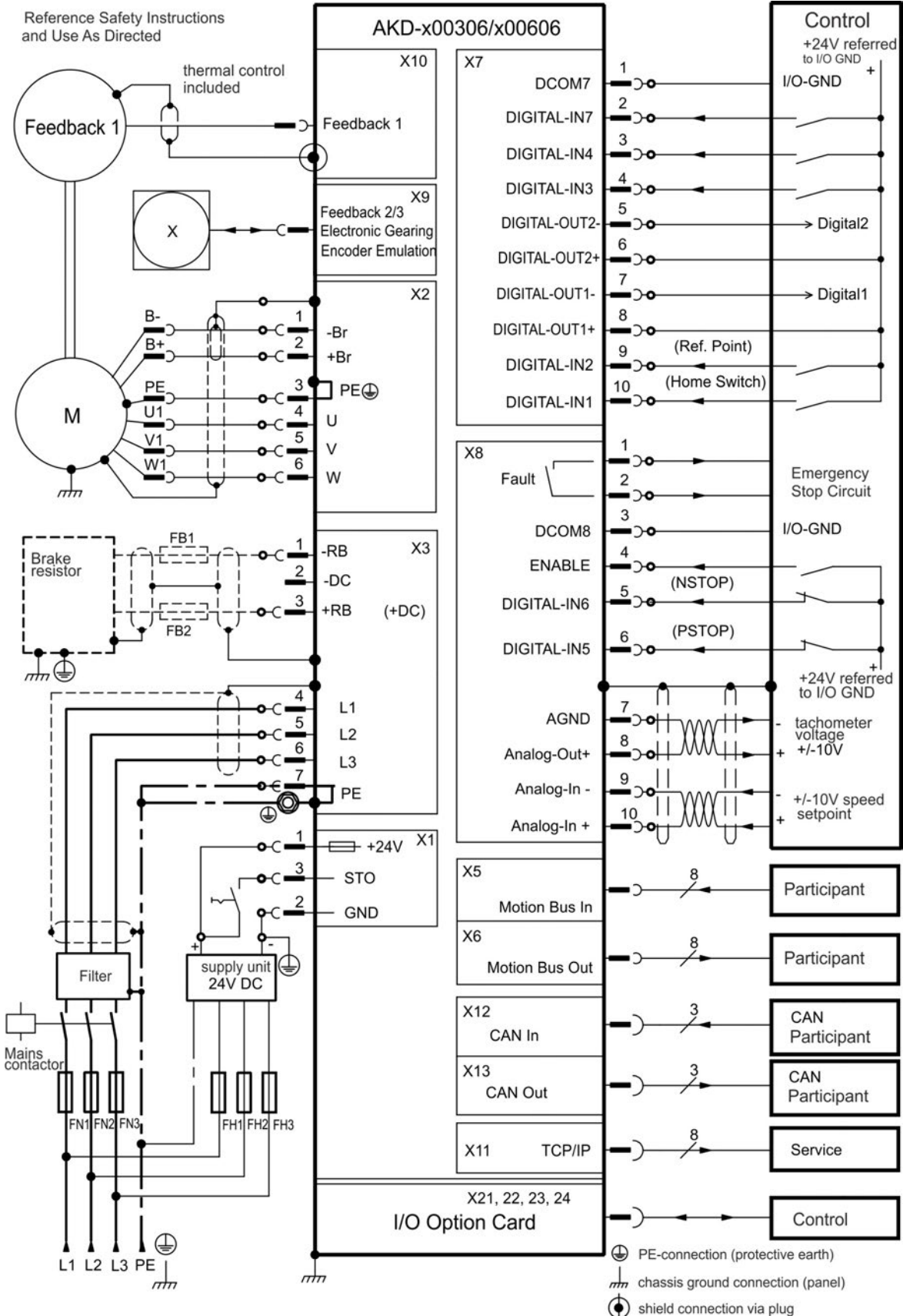

The I/O option is available for AKD-T drives only.

8.5.5 Connection diagram AKD-x01206

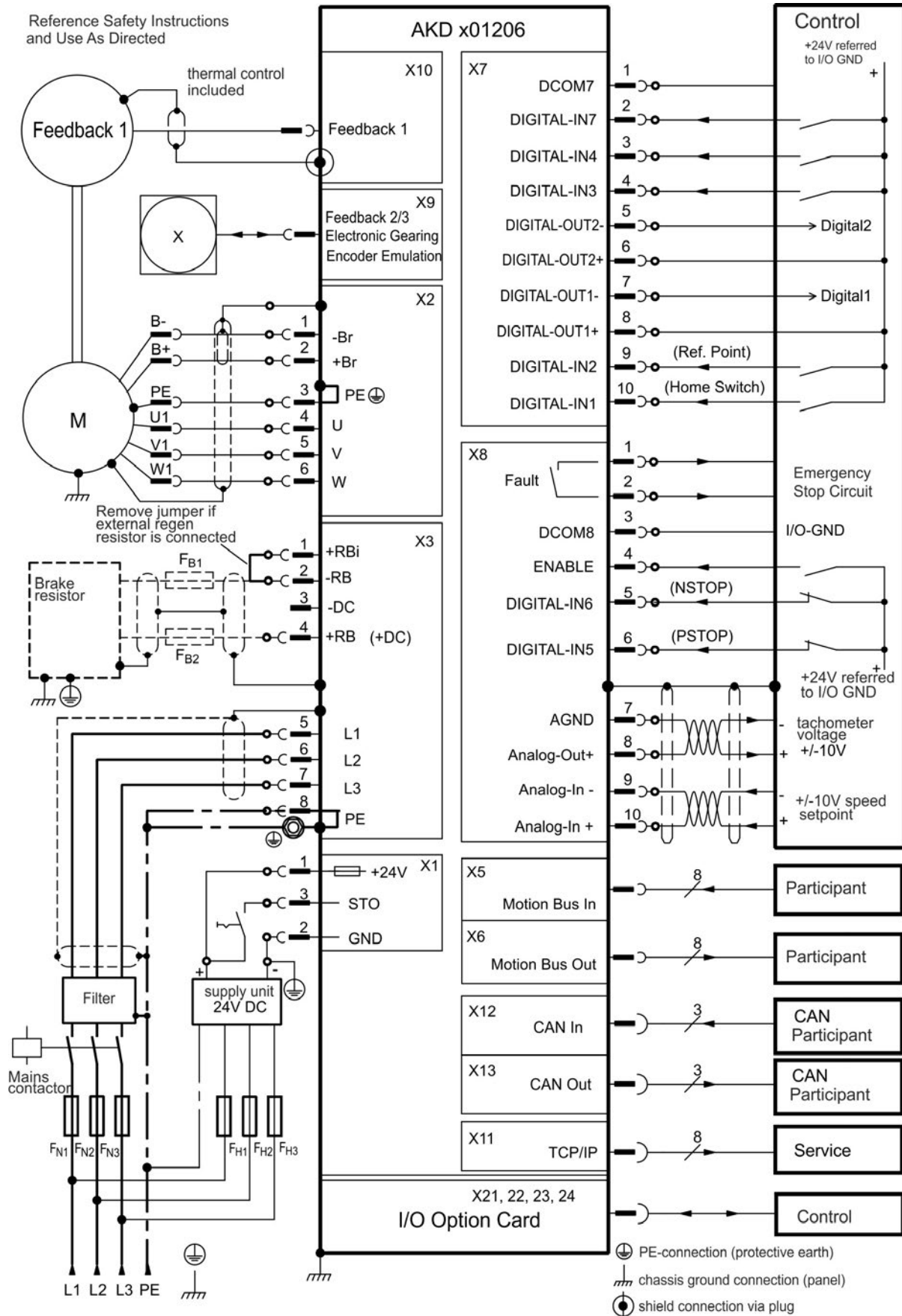

The I/O option is available for AKD-T drives only.

8.5.6 Connection diagram AKD-x02406 and AKD-xzzz07

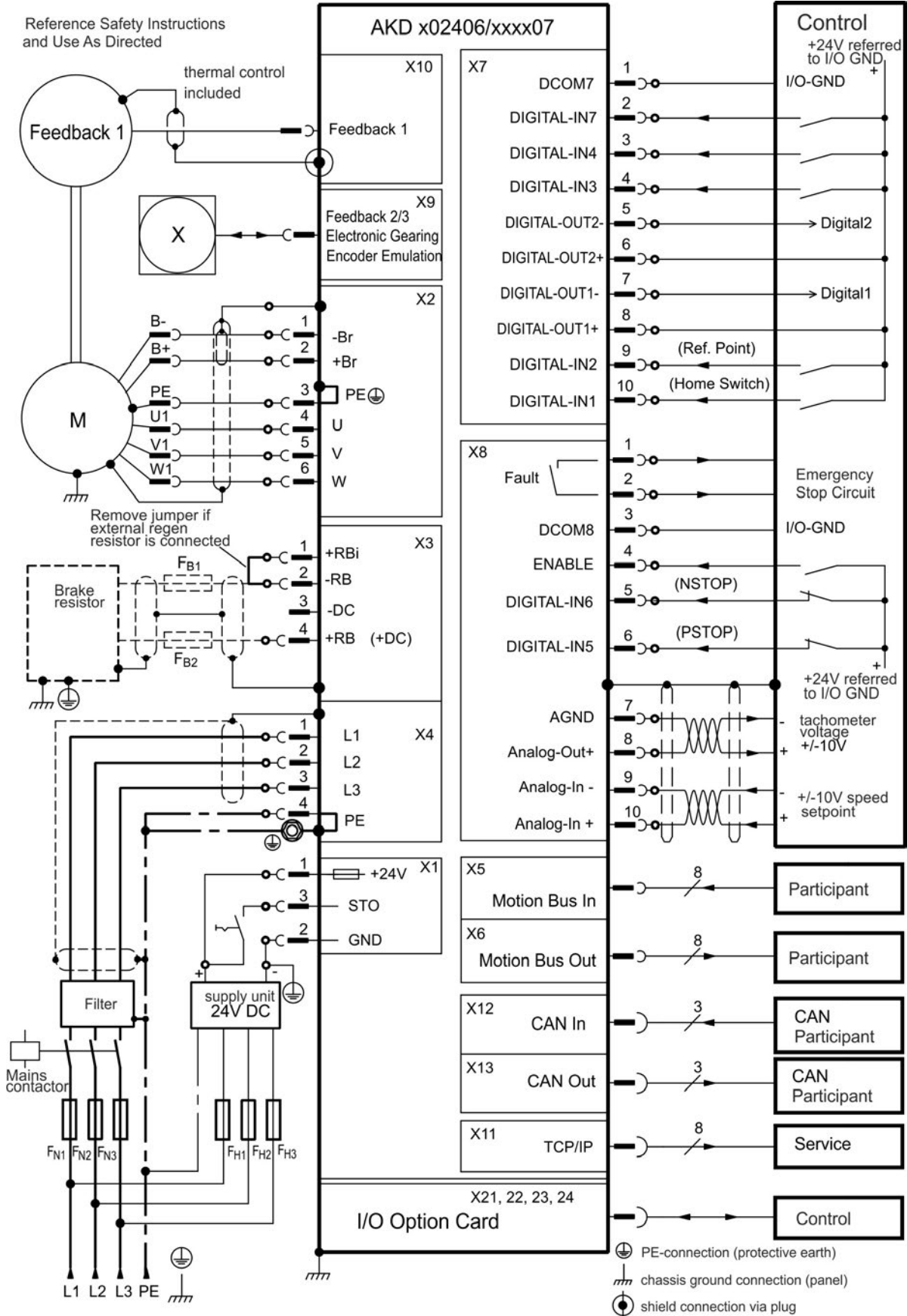

The I/O option is available for AKD-T drives only.

8.6 Connection Overview AKD-M

8.6.1 Connector assignment AKD-M00306, AKD-M00606

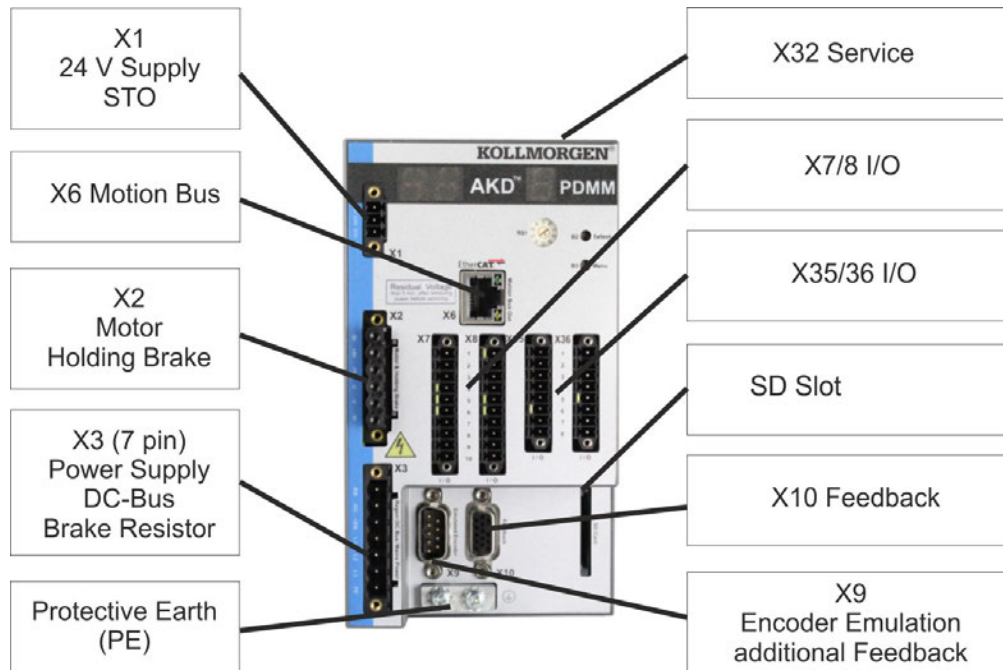

8.6.2 Connector assignment AKD-M01206

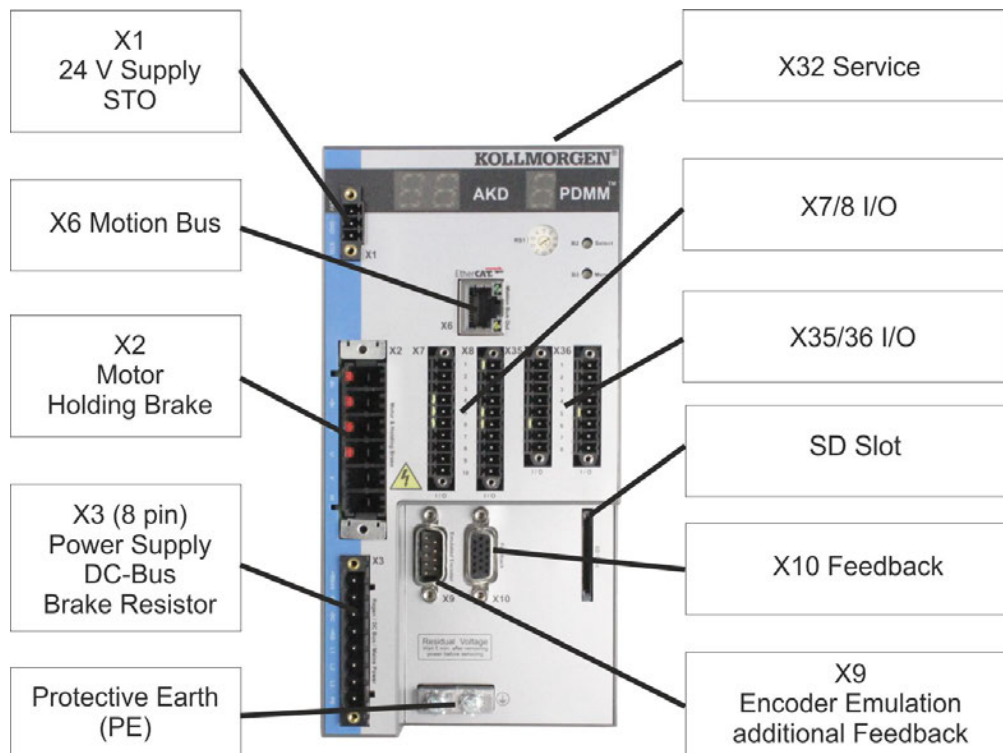

8.6.3 Connector assignment AKD-M02406 and AKD-Mzzz07

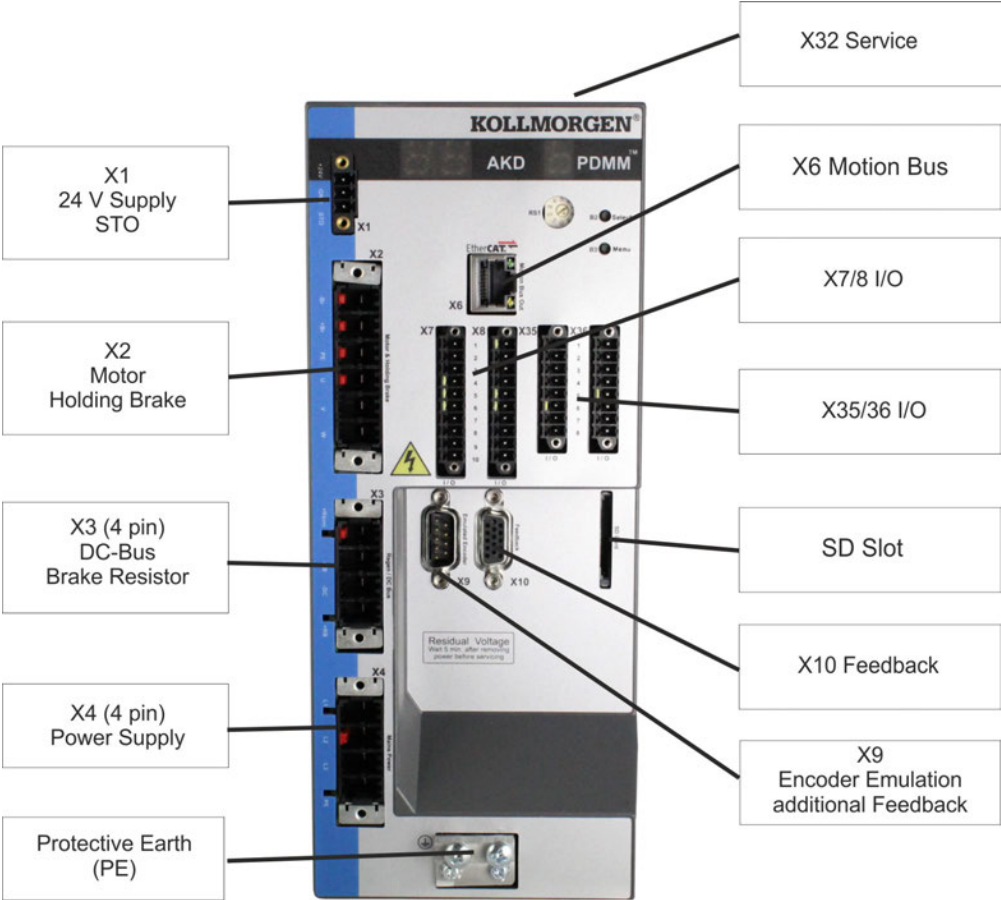

8.6.4 Connection diagram AKD-M00306, AKD-M00606

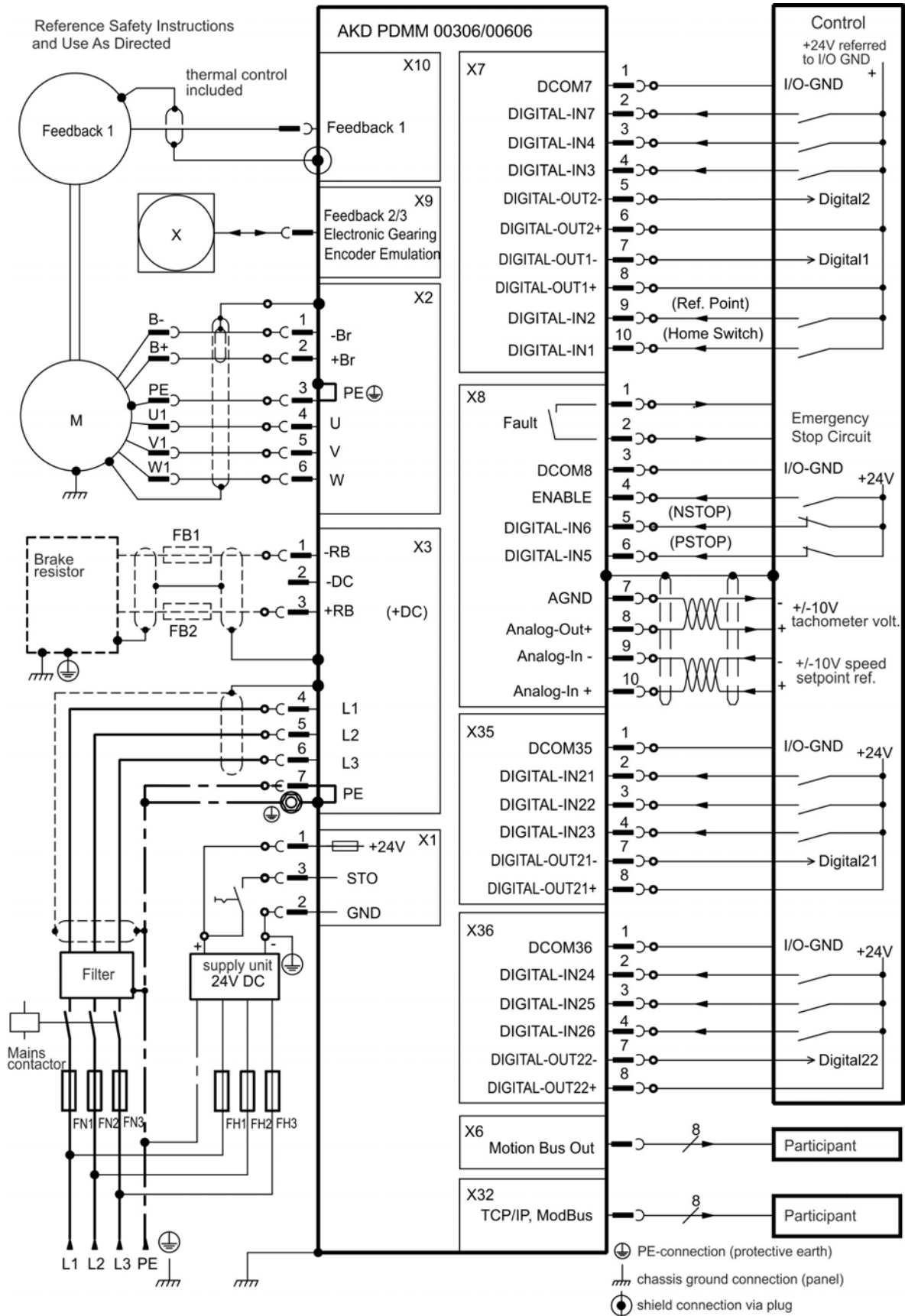

8.6.5 Connection diagram AKD-M01206

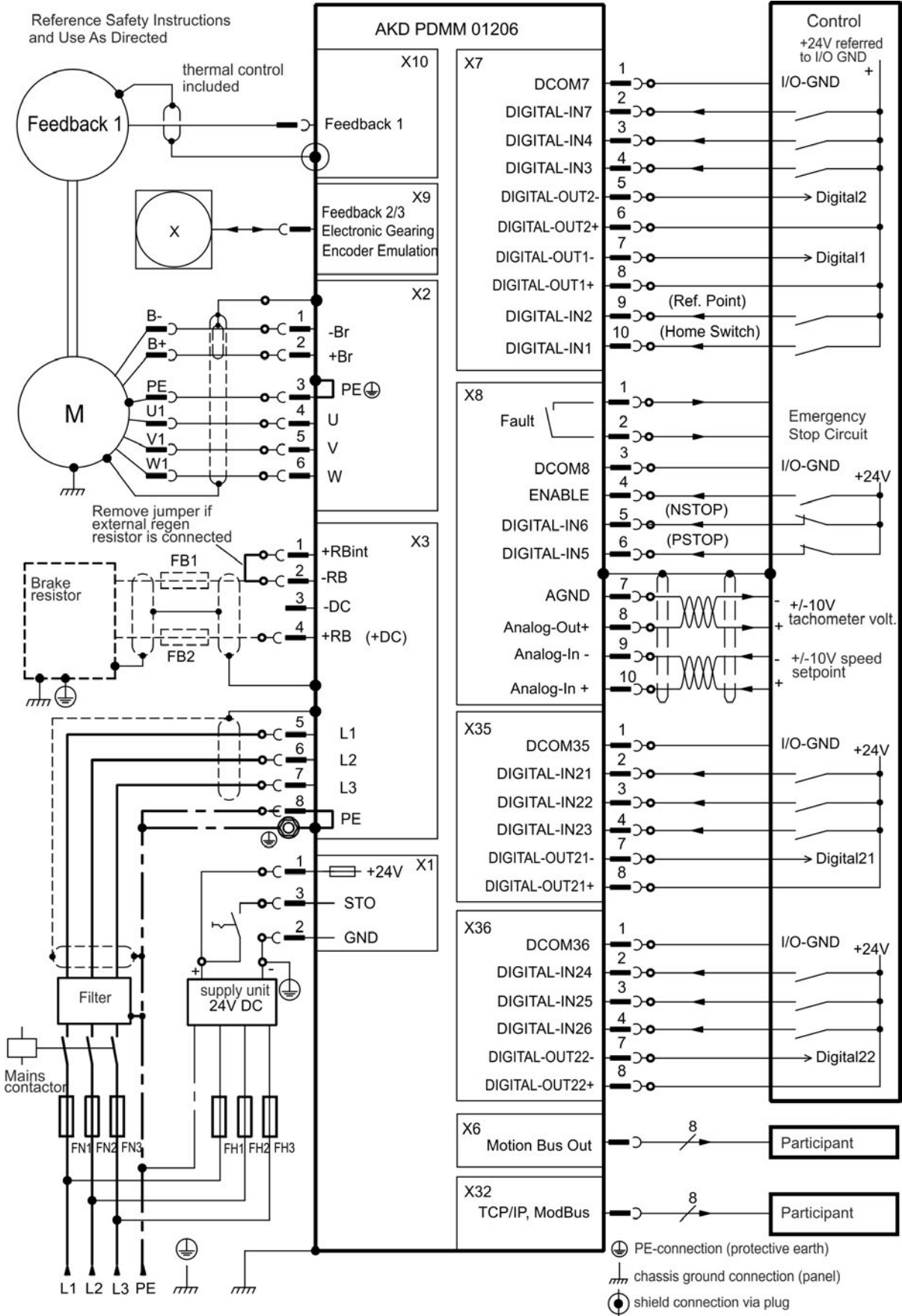

8.6.6 Connection diagram AKD-M02406 and AKD-Mzzz07

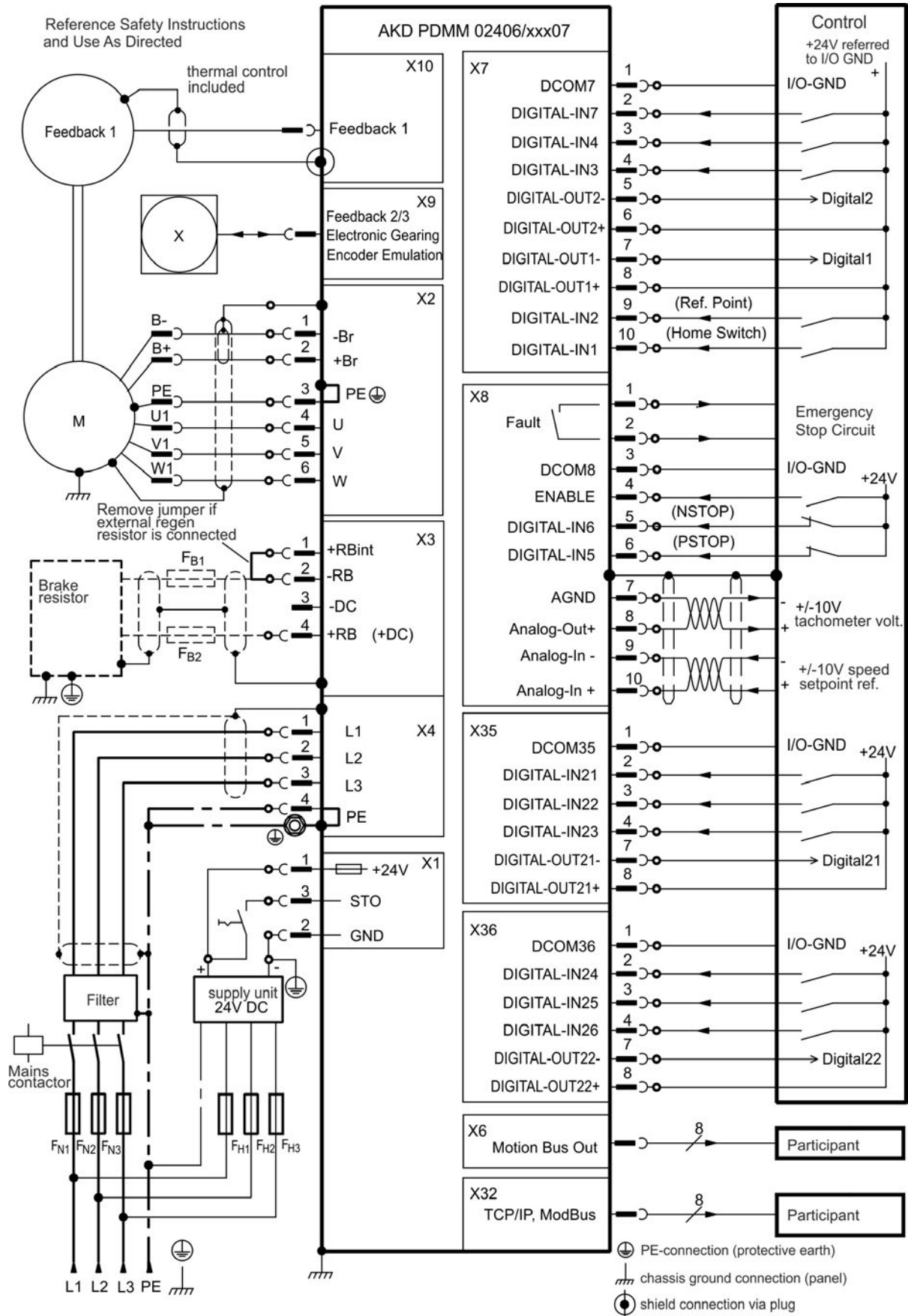

8.7 EMI Noise Reduction

8.7.1 Recommendations for EMI noise reduction

The following guidelines will help you to reduce problems with electrical noise in your application.

- Ensure good connections between the cabinet components.
Connect the back panel and cabinet door to the cabinet body using several conductive braids. Never rely on hinges or mounting bolts for ground connections. Provide an electrical connection across the entire back surface of the drive panel. Electrically-conductive panels such as aluminum or galvanized steel are preferred. For painted and other coated metal panels, remove all coating behind the drive.
- Ensure good ground connection.
Connect from cabinet to proper earth ground. Ground leads should be the same gauge as the leads to main power or one gauge smaller.
- Use Kollmorgen cables.
Experience has shown that customers who use Kollmorgen's power and feedback cables have far fewer problems than customers who build cables.
Route power and control cables separately, Kollmorgen recommends a distance of at least 200 mm to improve interference immunity.
If a motor power cable is used that includes cores for brake control, the brake control cores must be separately shielded.
- Ground the shielding at both ends.
Ground all shielding with large areas (low impedance), with metalized connector housings or shield connection clamps wherever possible. For cables entering a cabinet, connect shields on all 360° of the cable. Never connect a simple "pigtail." For more information on shielding concepts, → p. 86.
- With separate mains filter, maintain separation of leads entering and exiting the mains filter (line power filter).
Locate the filter as close as possible to the point where the incoming power enters the cabinet. If it is necessary for input power and motor leads to cross, cross them at 90°.
- Feedback lines may not be extended, since the shielding would be interrupted and the signal processing may be disturbed. Install all feedback cables with an adequate cross-section, per IEC 60204 (→ p. 39) and use the requested cable material to reach maximum cable length.
- Splice cables properly.
If you need to divide cables, use connectors with metal backshells. Ensure that both shells connect along the full 360° of the shields. No portion of the cabling should be unshielded. Never divide a cable across a terminal stripe
- Use differential inputs for analog signals.
Noise susceptibility in analog signals is greatly reduced by using differential inputs. Use twisted-pair, shielded signal lines, connecting shields on both ends.

8.7.2 Shielding with external shielding busbar

EMC filtering must be done externally by the user if necessary, which requires the use of shielded cables. Kollmorgen recommends a star point shield connection, for example, with a shielding busbar.

8.7.2.1 Shielding Concept

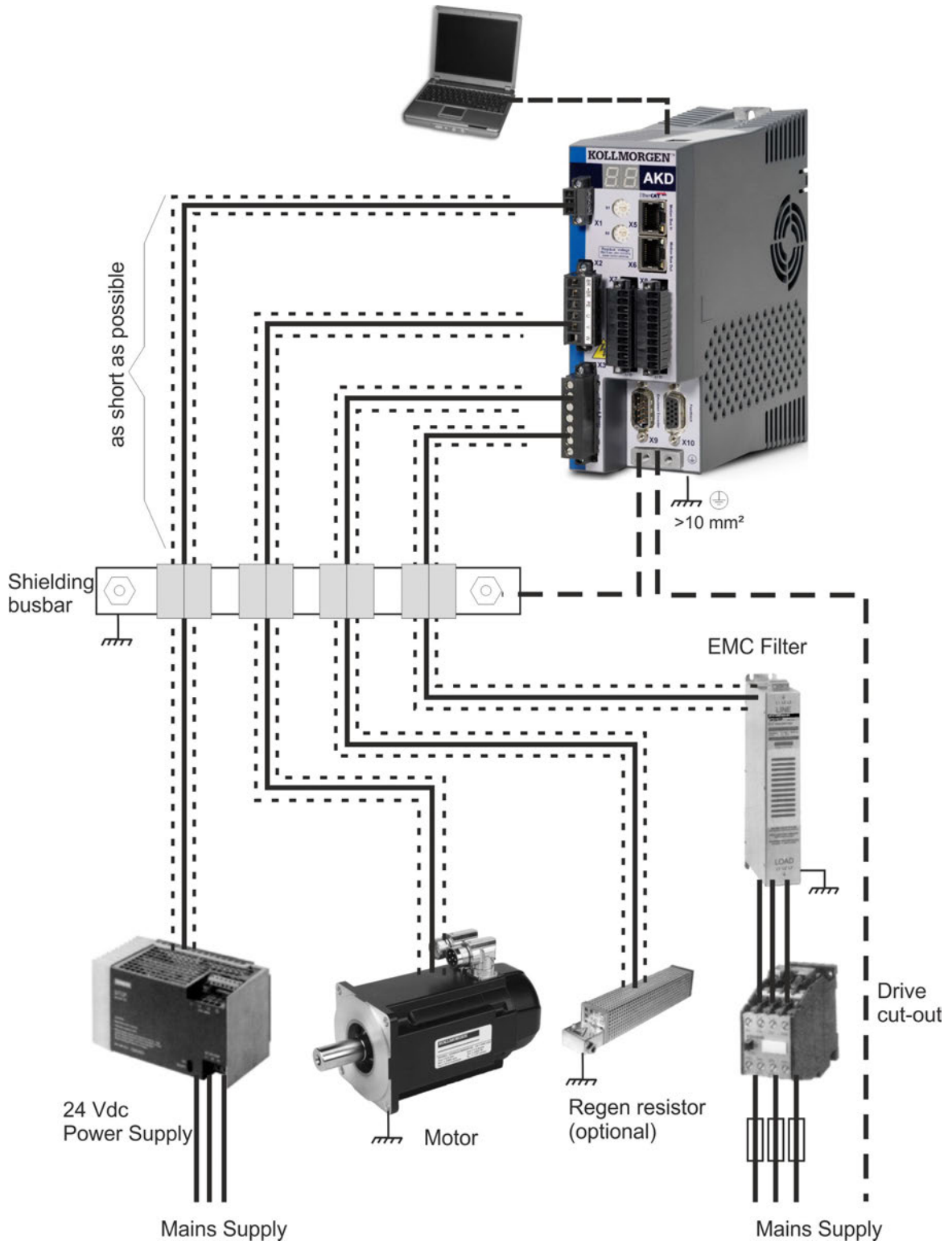

8.7.2.2 Shielding Busbar



The power cable shields (line in, motor cable, external regen resistor) can be routed to an additional busbar via shield clamps.

Kollmorgen recommends using Weidmüller KLBÜ shield clamps.

A possible scenario for setting up a busbar for the above shield clamps is described below.

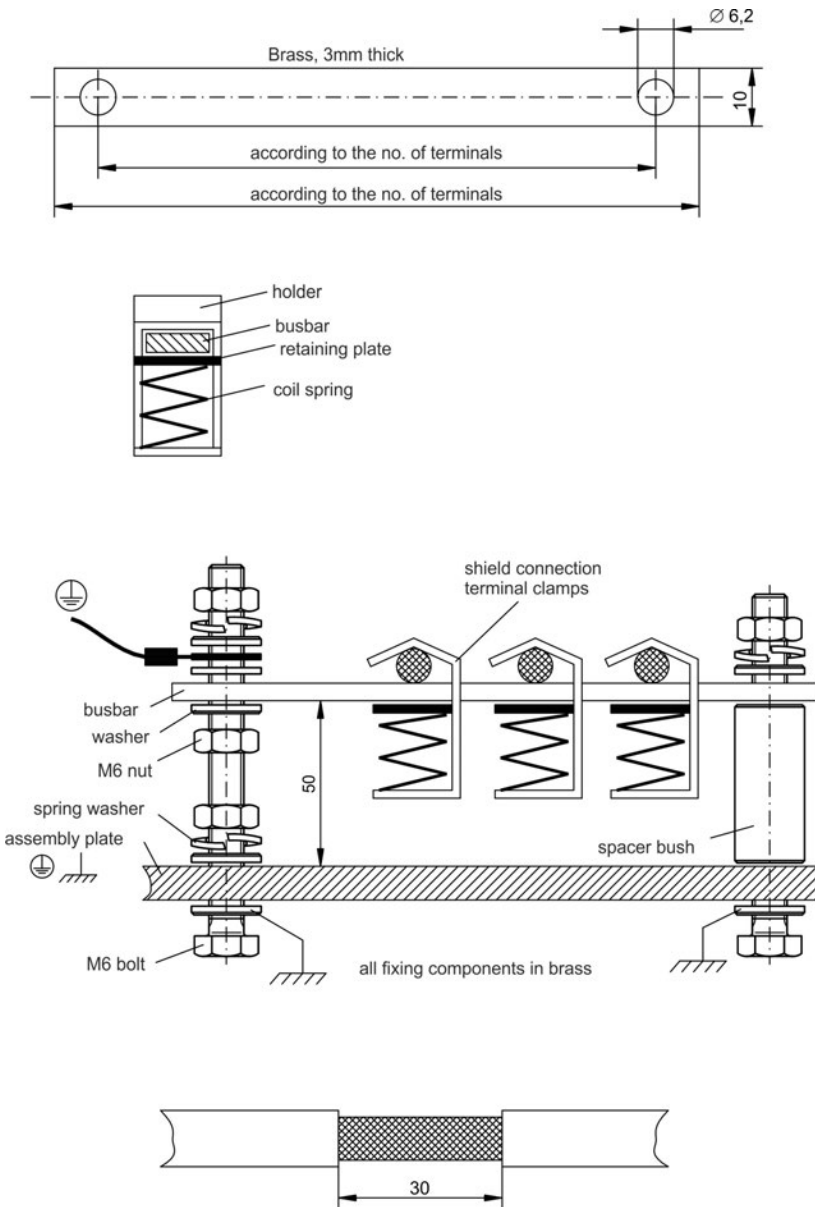

1. Cut a busbar of the required length from a brass rail (cross-section 10 x 3 mm) and drill holes in it as indicated. All shield clamps required must fit between the drill holes.

CAUTION
 Risk of injury due to the spring force of the coil spring. Use pliers.

2. Squeeze together the coil spring and the supporting plate and push the busbar through the opening in the holder.
3. Mount the busbar with the shield clamps fitted on the assembly plate. Use either metal spacer bushes or screws with nuts and accessories to maintain a spacing of 50 mm. Earth the busbar using a single conductor with a cross-section of at least 2.5 mm².
4. Strip the external cable sheath to a length of approx. 30 mm, taking care not to damage the braided shield. Push the shield clamp up and route the cable to it via the busbar.

NOTICE
 Make sure there is good contact between the shield clamp and the braided shield.

8.7.3 Shielding connection to the drive

You can connect cable shielding directly to the drive by using grounding plates, shield connection clamps, and a motor connector with strain relief and grounding plate.

8.7.3.1 Grounding plates

Mount the grounding plates to the drive as shown in the photos below.

AKD-x0306 to x1206 types:
L-shape grounding plate (EU only)

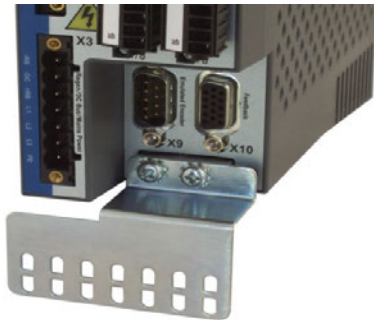

AKD-x02406 & zzz07 types:
flat grounding plate



8.7.3.2 Shield connection clamps



Use shield connection clamps (see accessories manual). These hook into the grounding plate and ensure optimum contact between the shield and the grounding plate.

Kollmorgen recommends using Phoenix Contact SK14 shield clamps with clamp range of 6-13mm.

8.7.3.3 Motor connector X2 with shielding connection

Alternative connection for the motor power connection by mating connector with strain relief.

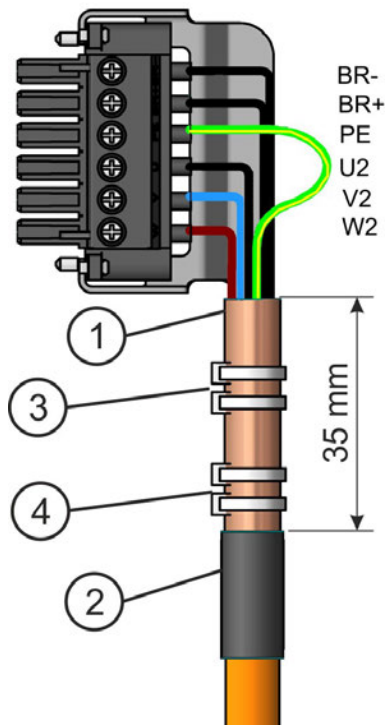

Strip the external cable sheath to a length of approx. 120 mm, taking care not to damage the braided shield. Push the braided shield (1) back over the cable and secure with a rubber sleeve (2) or shrink sleeve.

Shorten all the wires apart from the protective earth (PE) wire (green/yellow) by about 20 mm so that the PE wire is now the longest wire. Strip all wires and fit wire end ferrules.

Secure the braided shield of the cable to the shroud with a cable tie (3) and use a second tie (4) to fasten the cable.

Wire the connector as shown in the connection diagram. Plug in the connector to the socket on the front of the AKD.

Screw the connector in place. This ensures that there is conductive contact over a large surface area between the braided shield and the front panel.

8.8 Electrical Supply Connection

8.8.1 Connection to various mains supply networks AKD-xzzz06 (120V to 240V)

This page illustrates all the possible connection variations for different electrical supply networks.



⚠ WARNING

There is a danger of electrical shock with serious personnel injury if the drive is not properly grounded. An isolating transformer is always required for 400 to 480 V networks to get a maximum voltage of 240 V +10%.

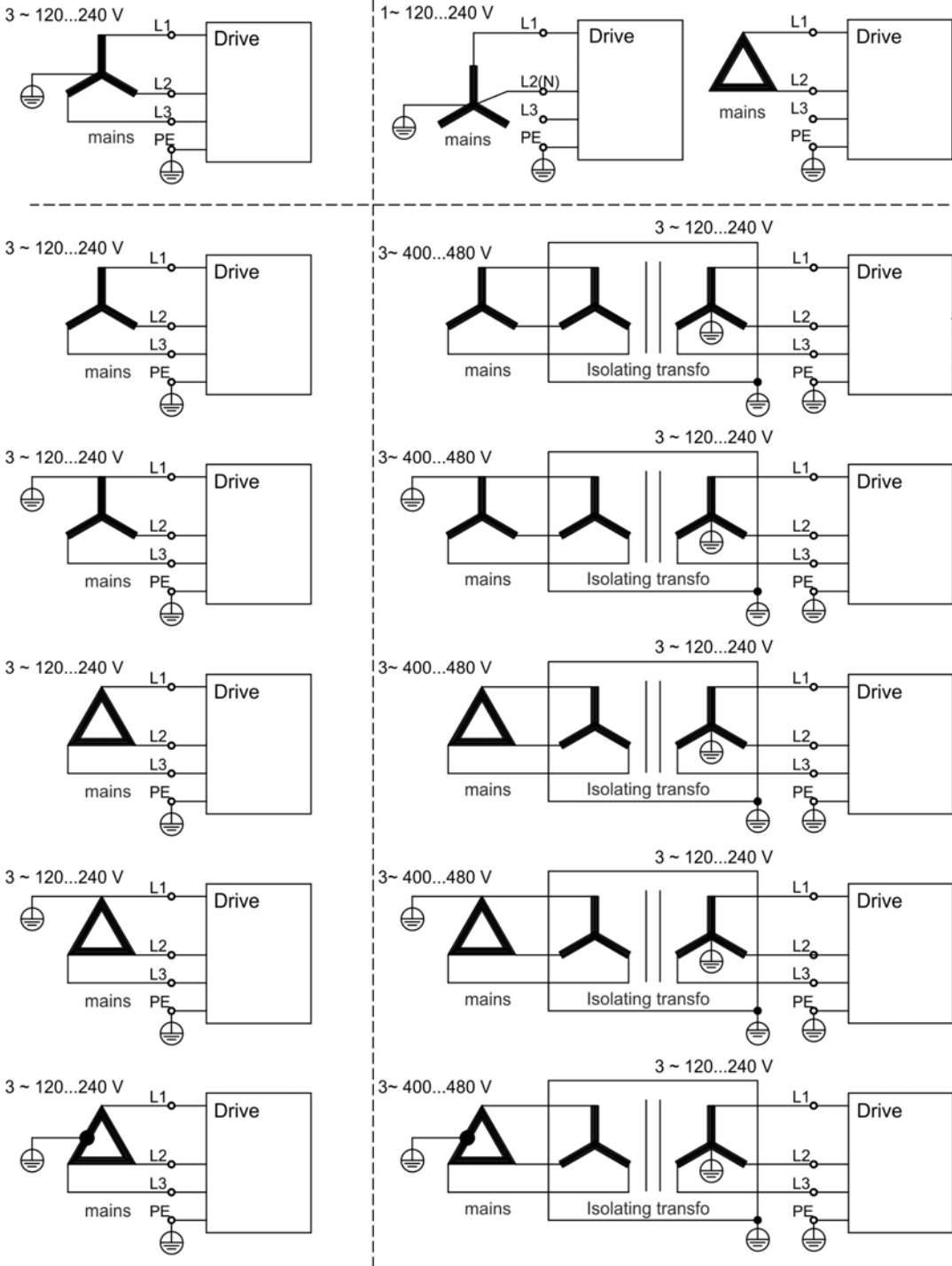

8.8.2 Connection to various mains supply networks AKD-xzzz07 (240V to 480V)

This page illustrates all the possible connection variations for different electrical supply networks.



WARNING

There is a danger of electrical shock with serious personnel injury if the drive is not properly grounded. An isolating transformer is always required for 120V networks to get a minimum voltage of 240 V +10%.

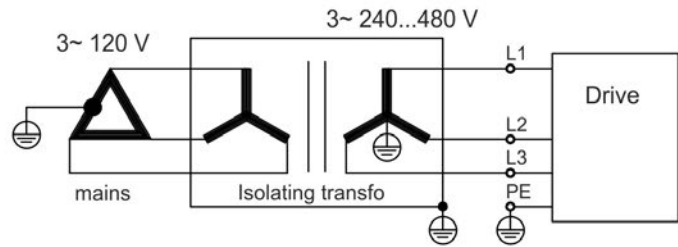
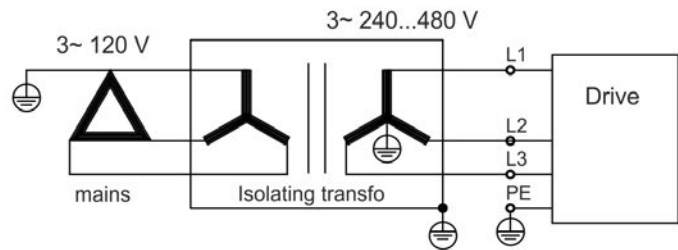
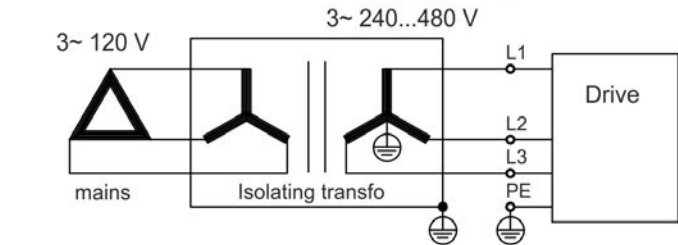
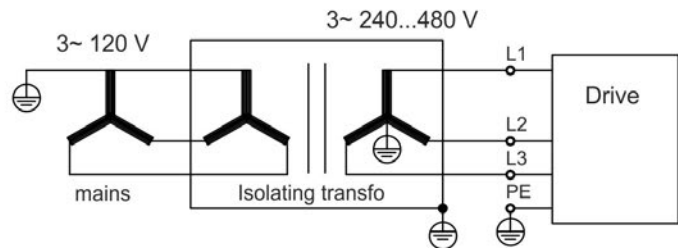
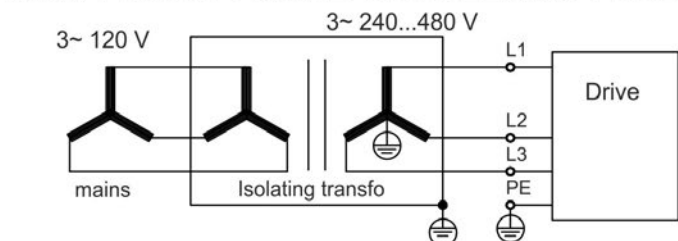
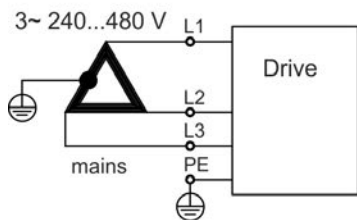
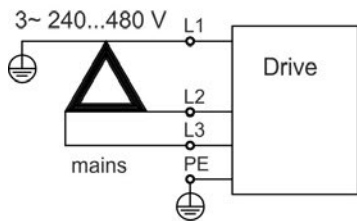
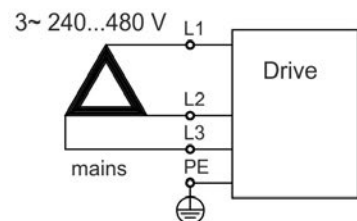
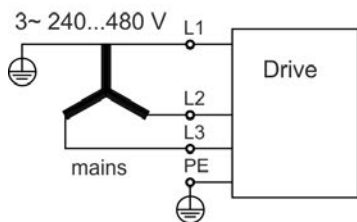
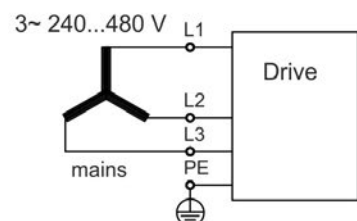
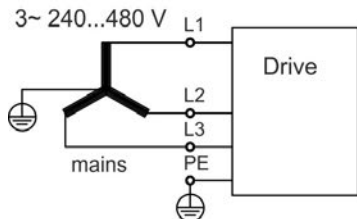

8.8.3 24 V auxiliary supply (X1)

The following diagram describes external 24 VDC power supply, electrically isolated, for example, via an isolating transformer. The required current rating depends on the use of motor brake and option card (→ p. 34 or → p. 35).

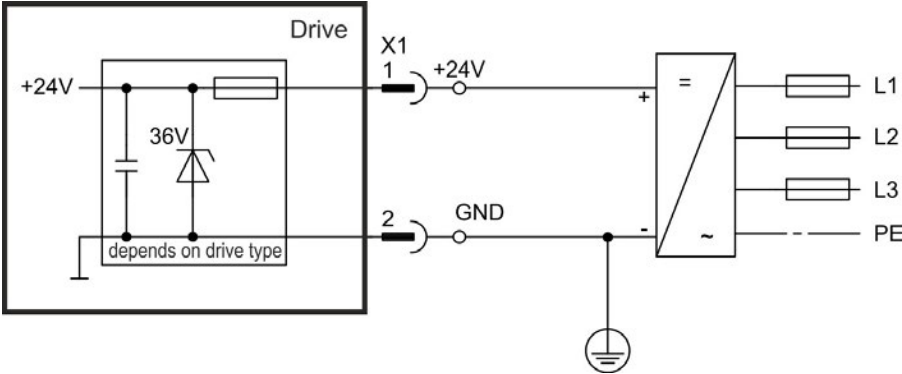

Pin	Signal	Description
1	+24	+24 VDC Auxiliary voltage
2	GND	24V Supply GND
3	STO	STO enable (Safe Torque Off)

8.8.4 Mains supply connection (X3, X4)

8.8.4.1 Three phase connection (all AKD types)

- Directly to 3-phase supply network, supply networks → p. 89
- Filtering for AKD-xzzz06 to be provided by the user.
- Fusing (such as fusible cut-outs) to be provided by the user → p. 37.

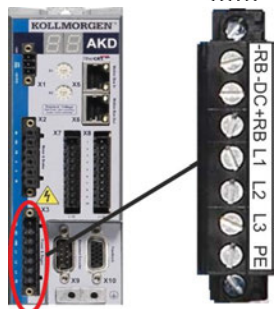
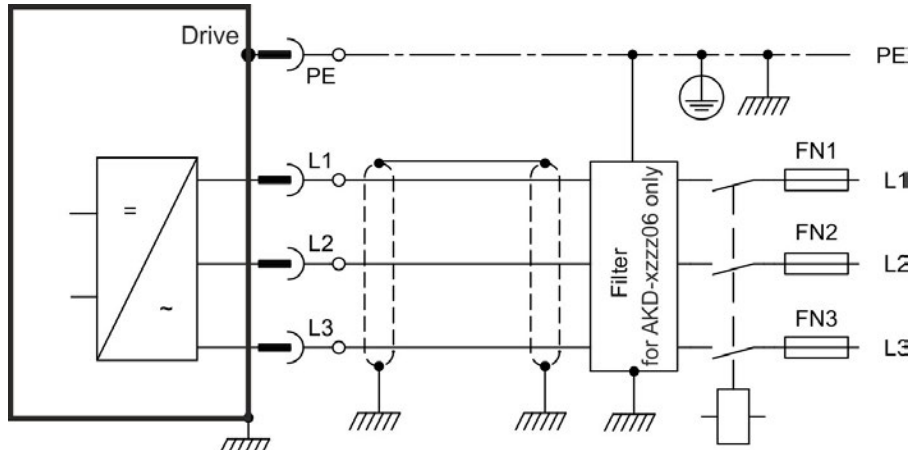

AKD-x00306 to AKD-x00606 (X3)		
Pin	Signal	Description
4	L1	Line 1
5	L2	Line 2
6	L3	Line 3
7	PE	Protective Earth

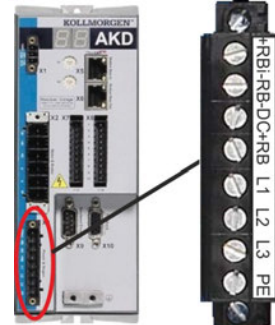

AKD-x01206 (X3)		
Pin	Signal	Description
5	L1	Line 1
6	L2	Line 2
7	L3	Line 3
8	PE	Protective Earth



AKD-x02406 & AKD-xzzz07 (X4)		
Pin	Signal	Description
1	L1	Line 1
2	L2	Line 2
3	L3	Line 3
4	PE	Protective Earth

8.8.4.2 Single phase connection (AKD-x00306 to AKD-x01206 only)

- Directly to single-phase supply network (→ p. 89)
- Supply networks
- Leave L3 open circuit
- Filtering to be provided by the user.
- Fusing (such as fusible cut-outs) to be provided by the user → p. 37

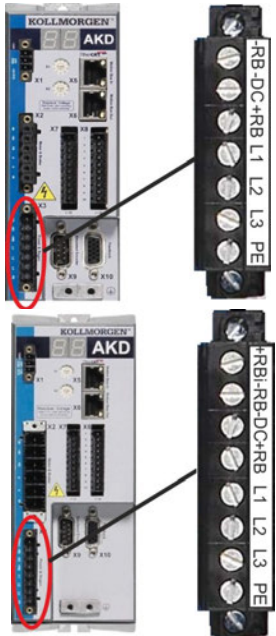
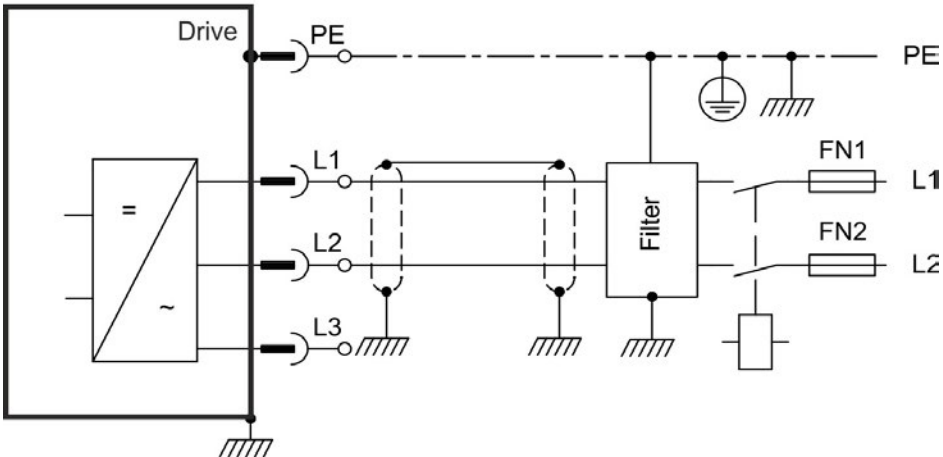
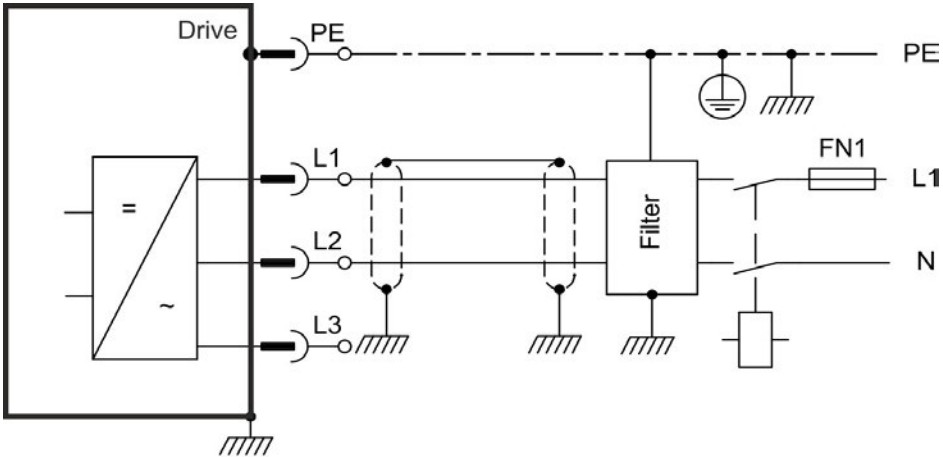

AKD-x00306 to AKD-x00606 (X3)		
Pin	Signal	Description
4	L1	Line 1
5	L2 (N)	Neutral or Line 2
7	PE	Protective Earth

AKD-x01206 (X3)		
Pin	Signal	Description
5	L1	Line 1
6	L2 (N)	Neutral or Line 2
8	PE	Protective Earth

8.9 DC Bus link (X3)

The DC bus link can be connected in parallel so that the regen power is divided between all the drives that are connected to the same DC bus link circuit. Every drive must have it's own power connection to mains voltage, even if the DC bus link is used.

NOTICE

The drive can be destroyed if DC bus link voltages are different. Only drives with mains supply from the same mains (identical mains phases and voltage) may be connected by the DC bus link. Use unshielded single cores with a maximum length of 200 mm. Use shielded cables for longer lengths.

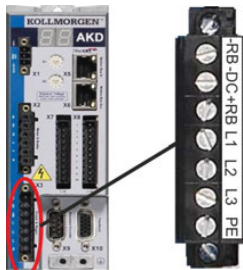
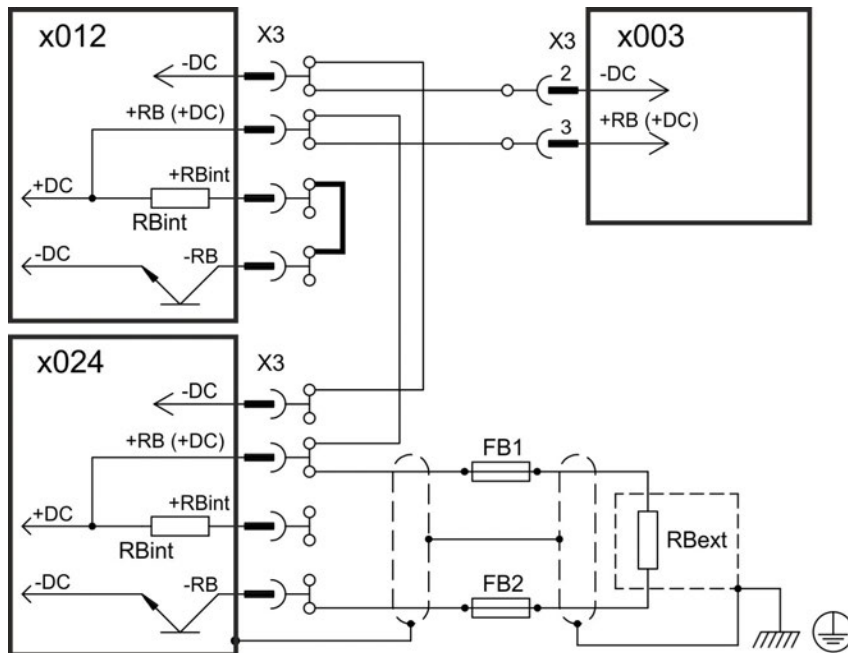

AKD-x00306 to AKD-x00606 (X3)		
Pin	Signal	Description
2	-DC	DC-Link Bus negative
3	+DC (+RB)	DC-Link Bus positive

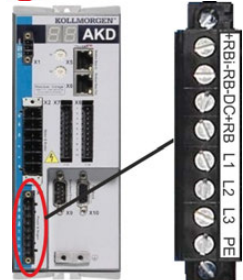

AKD-x01206 (X3)		
Pin	Signal	Description
3	-DC	DC-Link Bus negative
4	+DC (+RB)	DC-Link Bus positive

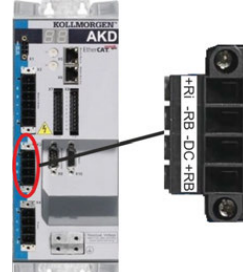

AKD-x02406 & AKD-xzzz07 (X3)		
Pin	Signal	Description
3	-DC	DC-Link Bus negative
4	+DC (+RB)	DC-Link Bus positive

8.9.1 External regen resistor (X3)

For technical data on the brake circuit "Dynamic Braking" (→ p. 40). Fusing (such as fusible cut-outs) to be provided by the user "Fusing" (→ p. 37).

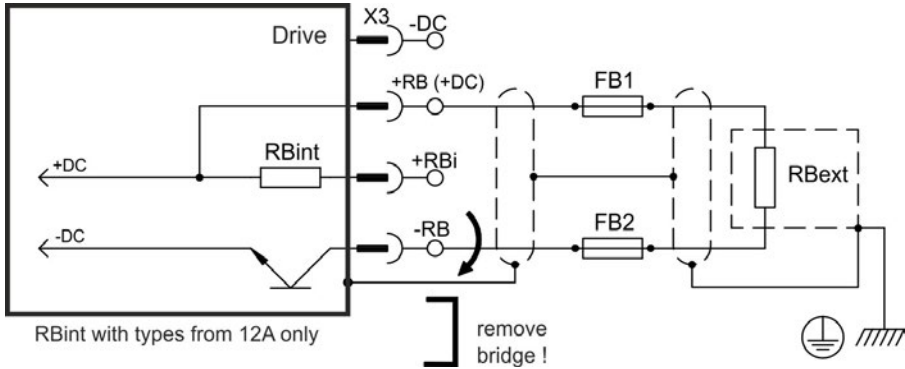

AKD-x00306 to AKD-x00606 (X3)		
Pin	Signal	Description
1	-RB	External Regen Resistor negative
3	+RB	External Regen Resistor positive

AKD-x01206 (X3)		
Pin	Signal	Description
1	+Rbint	Internal RegenResistor positive
2	-RB	External RegenResistor negative
4	+RB	External RegenResistor positive

AKD-x02406 & AKD-xzzz07 (X3)		
Pin	Signal	Description
2	-RB	External RegenResistor negative
4	+RB	External RegenResistor positive

8.9.2 Capacitor Modules (X3)



KCM modules (**K**OLL**M**OR**G**EN **C**apacitor **M**odules) absorb kinetic energy generated by the motor when it is operating in generator mode. Normally, this energy is dissipated as waste via regen resistors. KCM modules, however, feed the energy they have stored back into the DC Bus link as and when it is required.

Assembly information: see regional accessories manual or KCM instruction manual.

Dimensions (HxWxD) : 300x100x201 mm

KCM-S	Saves energy: The energy stored in the capacitor module during generative braking is available the next time acceleration happens. The module's inception voltage is calculated automatically during the first load cycles.
KCM-P	Power in spite of power failure: If the power supply fails, the module provides the servo amplifier with the stored energy that is required to bring the drive to a standstill in a controlled manner (this only applies to the power supply voltage; battery-back the 24 V supply separately).
KCM-E	Expansion module for both applications. Expansion modules are available in two capacitance classes.

NOTE

The KCM modules may only be connected to AKD with 400/480 V rated voltage and a maximum rated current of 24 A. Mounting, installation, and setup instructions can be found in the Instructions Manual of the KCM Modules.



! DANGER

DC Bus link terminals in servo systems carry high DC voltage of up to 900 V. Touching the terminals while they are carrying voltage is extremely dangerous. Switch off (disconnect) the line voltage. You must only work on the connections when the system is disconnected.

It can take over an hour for the modules to self-discharge. Check the state of charge with a measuring device that is suitable for a DC voltage of up to 1,000 V. When measuring a voltage of over 60 V between the DC+/DC- terminals or to ground, discharge the modules (see "Discharging KCM modules" (→ p. 99)).

8.9.2.1 Technical Data

Type	Storage-Capacity [Ws]	Rated Supply Voltage [V DC]	Peak Supply Voltage [V DC]	Power [kW]	Protection Class	Inception Voltage [V DC]	Weight [kg]
KCM-S200	1600	max. 850	max. 950 (30s in 6 min)	18	IP20	evaluated	6.9
KCM-P200	2000					470	6.9
KCM-E200	2000					-	4.1
KCM-E400	4000					-	6.2

8.9.2.2 Example installation with KCM-S and KCM-E

NOTICE

Maximum cable length between AKD and KCM: 500mm. The DC+ and DC- lines should always be twisted, maximum cross section is 6mm². Ensure that the polarity is correct, swapping round DC+/DC- will damage the KCM modules.

Connect the BR connection to the AKD with the most frequent generative braking processes in the system. This AKD must have an active internal or external brake resistor. Create a motion profile that causes the brake chopper to respond.

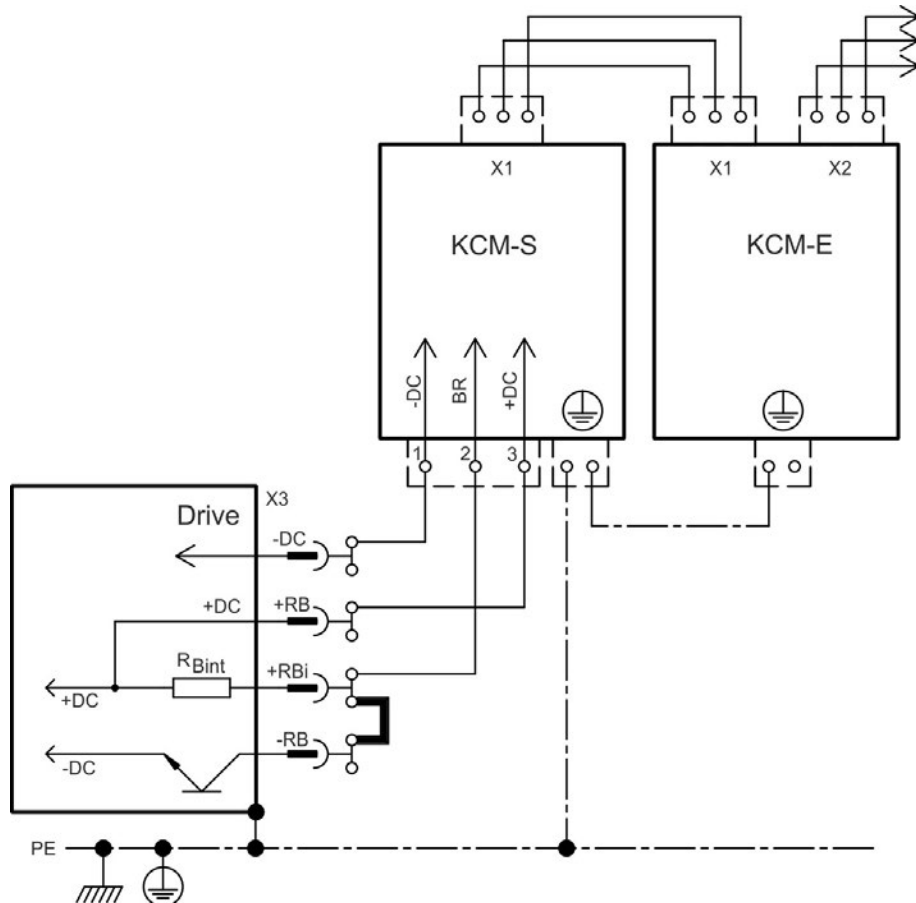

Setup KCM-S and KCM-E

Prerequisite for the following instructions:

- Properly disconnected, grounded system.
- KCM-S: assembled and wired in the switching cabinet. The load that leads to the activation of the brake chopper during braking must be connected.
- KCM-E: assembled and connected to the KCM-S with connection cable (X1) and PE line.
- Discharge aids (plug-in bridge) are removed.

Proceed as instructed below:

1. Switch on the line voltage.
2. Enable the AKD and operate the motion profile that causes the brake chopper to respond.
3. The KCM-S determines the chopper threshold and begins to charge; LED (top view) flashes. The energy stored in the capacitor module during generative braking is available the next time acceleration happens.

8.9.2.3 Example installation with KCM-P and KCM-E

NOTICE

Maximum cable length between AKD and KCM: 500mm. The DC+ and DC- lines should always be twisted, maximum cross section is 6mm². Ensure that the polarity is correct, swapping round DC+/DC- will damage the KCM modules.

The KCM-P starts the charging process at approx. 470 V DC. If the power supply fails, the module provides the DC bus link with the stored energy (this only applies to the power supply voltage; battery-back the 24 V supply separately).

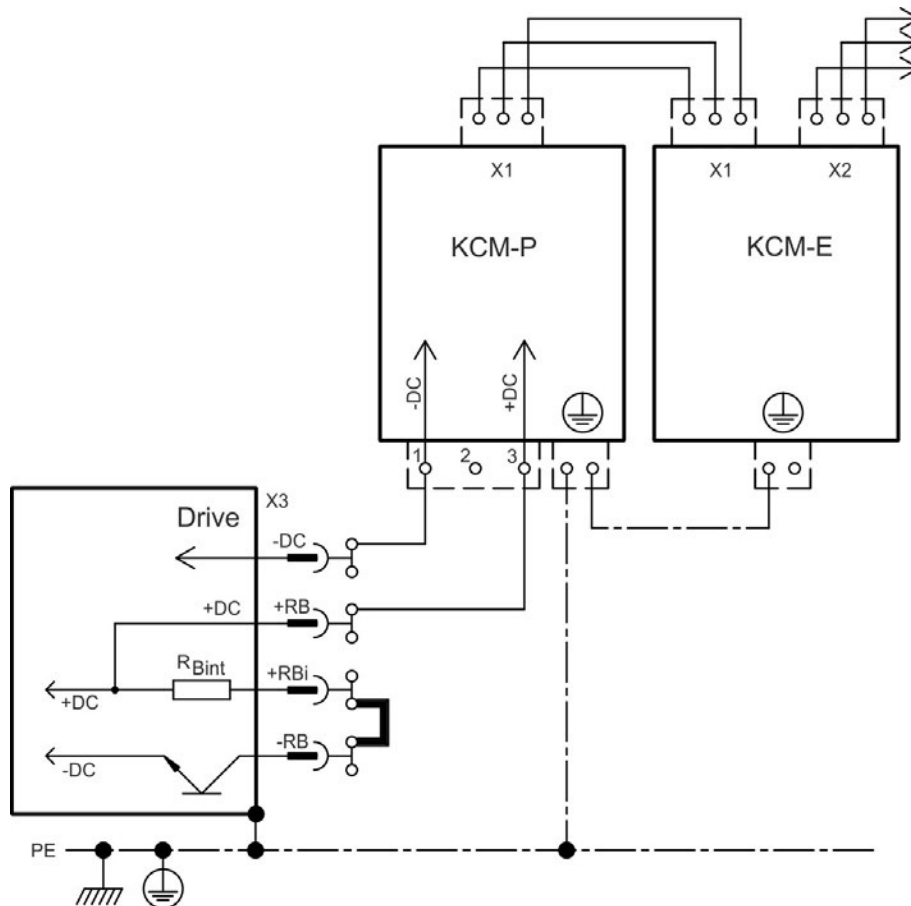

Setup KCM-P and KCM-E

Prerequisite for the following instructions:

- Properly disconnected, grounded system.
- KCM-P: assembled and wired in the switching cabinet. Set AKD undervoltage limit VBUS.UVTHRESH to a value significantly below 470V DC, otherwise AKD will switch-off before KCM-P provides energy to the DC bus link.
- KCM-E: assembled and connected to the KCM-P with connection cable (X1) and PE line.
- Discharge aids (plug-in bridge) are removed.

Proceed as instructed below:

1. Switch on the line voltage.
2. The KCM-P begins the charging process at approx. 470 V DC; the LED flashes.

8.9.2.4 Discharging KCM modules

The aids supplied with each KCM module (plug-in bridge/connecting cables) allows discharging the modules safely.

NOTICE

When the charging LED on top of the modules flashes, the capacitors are charged. Please note, however, that the LED does not allow you to draw a definite conclusion about the state of discharge, as it is not monitored for failures.



DANGER

DC Bus link terminals in servo systems carry high DC voltage of up to 900 V. Touching the terminals while they are carrying voltage is extremely dangerous.

Switch off the line voltage (disconnect the system). You must only work on the connections when the system is disconnected.

Check the state of charge of the capacitors with a measuring device that is suitable for a DC voltage of up to 1,000 V. Wait until the voltage measured between the DC+/DC- terminals or to ground has sunk below 60 V. It can take over an hour for the modules to self-discharge. If you cannot wait for the duration of the self-discharge time, you must force the modules to discharge.

You must follow the procedure described below when forcing the modules to discharge.

For your own safety, proceed as follows when forcing the modules to discharge:

1. Switch off (disconnect) the line voltage.
2. Discharge the modules:
 - KCM-S/-P:** Insert the plug-in bridge in the screw terminals (black-1 to gray-2) on the base of the modules, wait at least 70 s, leave the plug-in bridge in place (as a means of securing for transport). Remove the plug-in bridge again before recommissioning.
 - KCM-E:** Bridge the X2/X3 connector with a connecting cable on the top of the module, wait at least 70 s, leave the connecting cable in place (as a means of securing for transport). Detach the connecting cable and reconnect the KCM-E properly before recommissioning.
3. Perform the scheduled task (e.g., cleaning, maintenance, or uninstallation).

8.10 Motor Connection

Together with the motor supply cable and motor winding, the power output of the drive forms an oscillating circuit. Characteristics such as cable capacity, cable length, motor inductance, and frequency (→ p. 34 or → p. 35) determine the maximum voltage in the system.

The AKD-N drive is able to protect the connected motor from overloading, if the parameters are set correctly and the thermal protection sensor is connected and supervised. With Kollmorgen motors the valid data are automatically set by the internal motor database. With motors from other manufacturers the data from the nameplate must be entered to the referring fields in the motor view of the Kollmorgen setup software WorkBench.

NOTICE

The dynamic voltage rise can lead to a reduction in the motor operating life and, on unsuitable motors, to flashovers in the motor winding.

- Only install motors with insulation class F (acc. to IEC60085) or above.
- Only install cables that meet the requirements → p. 39.

Connector X2 AKD-xzzz06

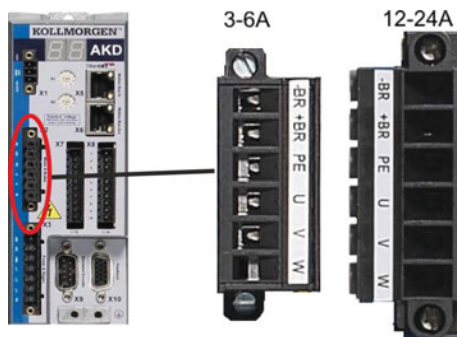

Pin	Signal	Description
1	-BR	Motor holding brake, negative
2	+BR	Motor holding brake, positive
3	PE	Protective earth (motor housing)
4	U	Motor phase U
5	V	Motor phase V
6	W	Motor phase W

Connector X2 AKD-xzzz07

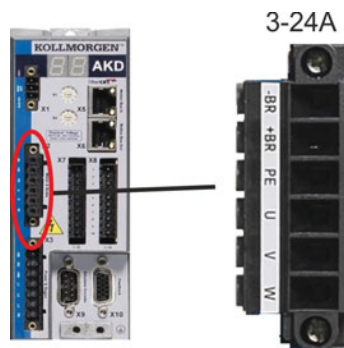

Pin	Signal	Description
1	-BR	Motor holding brake, negative
2	+BR	Motor holding brake, positive
3	PE	Protective earth (motor housing)
4	U	Motor phase U
5	V	Motor phase V
6	W	Motor phase W

8.10.1 Motor power (X2)

8.10.1.1 Cable length ≤ 25 m

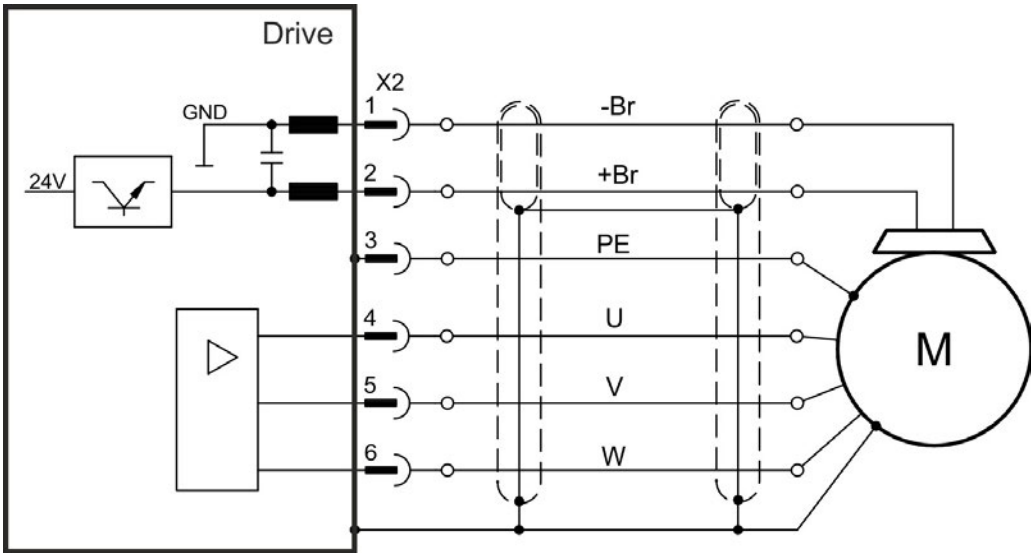

8.10.1.2 Cable length >25 m

NOTICE

With long motor cables leakage currents endanger the output stage of the drive. For cable lengths from 25 m to 50 m, a motor choke must be wired into the motor cable (near the drive).

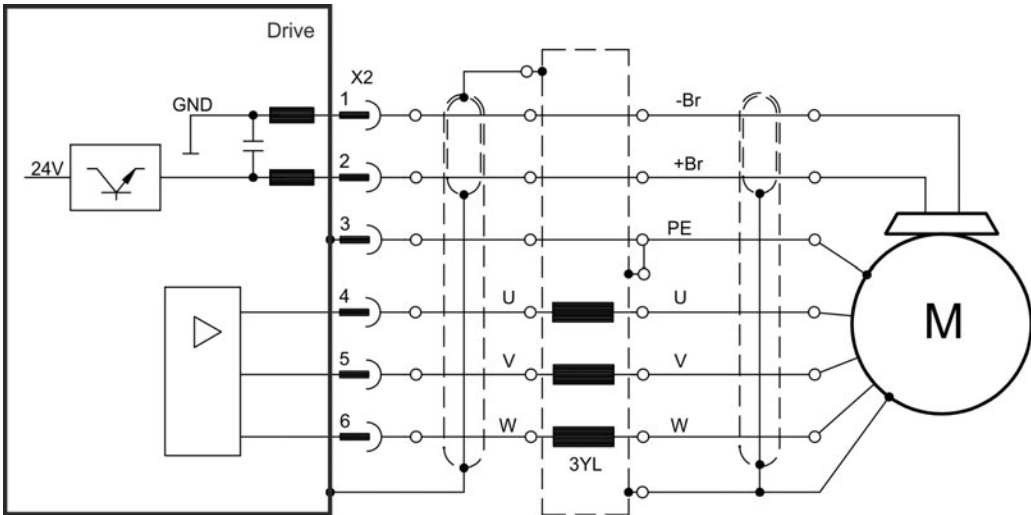

8.10.2 Motor holding brake (X2)

A 24 V holding brake in the motor can be controlled directly by the drive. The brake only works with sufficient 24 V voltage level (→ p. 34 or → p. 35). Check voltage drop, measure the voltage at brake input and check brake function (brake and no brake).



CAUTION

This function does not ensure functional safety. Functional safety requires and additional, external mechanical brake, operated by a safety controller. The Hardware Enable (connector X8 pin4) does not initiate a controlled stop but switches off the power stage immediately. Set parameter MOTOR.BRAKEIMM to 1 with vertical axes, to apply the brake immediately after faults or Hardware Disable.

The brake function must be enabled through a parameter. The diagram below shows the timing and functional relationships between the controlled stop signal, speed setpoint, speed, and braking force. All values can be adjusted with parameters; values in the diagram are default values.

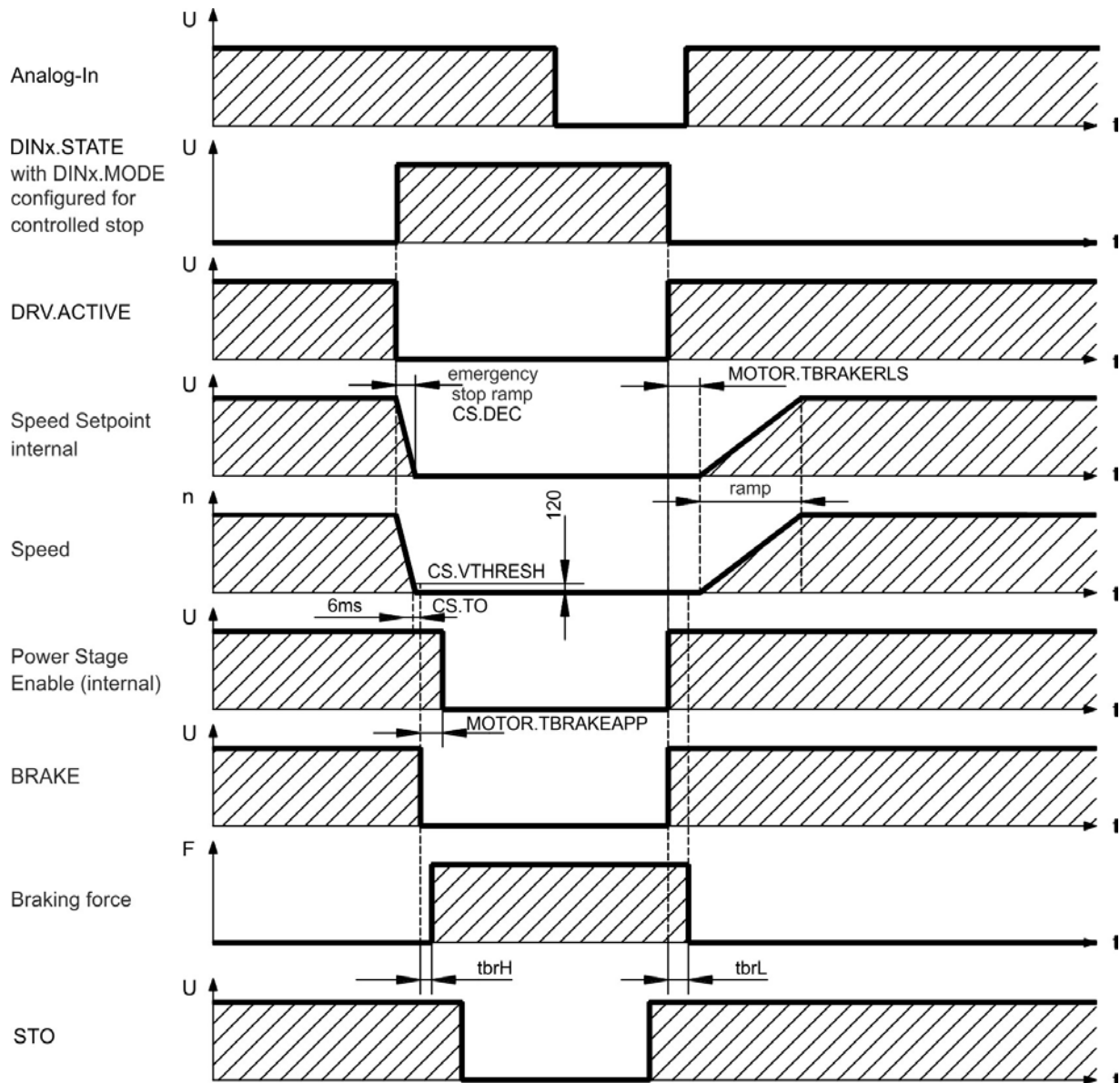

The speed setpoint of the drive is internally driven down an adjustable ramp (CS.DEC) to 0 V. With default values the output for the brake is switched on when the speed has reached 120 rpm (CS.VTHRESH) for at least 6 ms (CS.TO). The rise (t_{brH}) and fall (t_{brL}) times of the holding brake that is built into the motor are different for the various types of motor (see motor manual).

8.11 Feedback Connection

Every closed servo system normally requires at least one feedback device for sending actual values from the motor to the drive. Depending on the type of feedback device used, information will be fed back to the drive using digital or analog means.

AKD supports the most common types of feedback device. Two feedback devices can be used at the same time, and all feedbacks are connected to X10. Feedback functions are assigned with parameters in WorkBench, the setup software. Scaling and other settings are also performed in WorkBench. For a detailed description of the parameters, please refer to the WorkBench online help.

The table below provides an overview of the supported feedback types, their corresponding parameters, and a reference to the relevant connection diagram in each case.

Feedback Types	Wiring	Connector	FBTYPE
Resolver	→ p. 105	X10	40
SFD	→ p. 106	X10	41
SFD3	→ p. 107	X10	45
Encoder Hiperface DSL	→ p. 108	X10	46
SinCos Encoder BiSS B (analog)	→ p. 109	X10	32
Encoder BiSS C (digital)	→ p. 110	X10	34
SinCos Encoder ENDAT 2.1	→ p. 111	X10	30
Encoder ENDAT 2.2	→ p. 112	X10	31
SinCos Encoder Hiperface	→ p. 113	X10	33
Sine Encoder + Hall	→ p. 114	X10	20
Sine Encoder (Wake&Shake)	→ p. 114	X10	21
Incremental Encoder + Hall	→ p. 115	X10	10
Incremental Encoder (Wake&Shake)	→ p. 115	X10	11
Tamagawa Smart Abs	→ p. 116	X10	42

8.11.1 Feedback connector (X10)

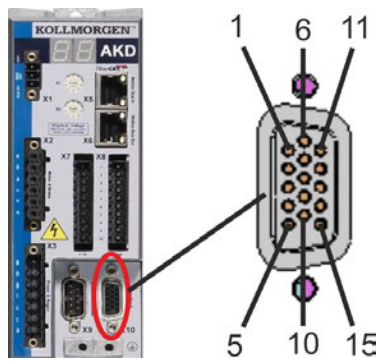

PIN	SFD	SFD3/DSL	Resolver	BiSS B (analog)	BiSS C (digital)	EnDAT 2.1	EnDAT 2.2	Hiper-face	Sine Enc. +Hall	Tamagawa Smart Abs	Incr. Enc. +Hall
1	-	-	-	-	-	-	-	-	Hall U	-	Hall U
2	-	-	-	CLK+	CLK+	CLK+	CLK+	-	Hall V	-	Hall V
3	-	-	-	CLK-	CLK-	CLK-	CLK-	-	Hall W	-	Hall W
4	SEN+	-	-	SEN+	SEN+	SEN+	SEN+	SEN+	SEN+	SEN+	SEN+
5	SEN-	-	-	SEN-	SEN-	SEN-	SEN-	SEN-	SEN-	SEN-	SEN-
6	COM+	COM+	R1 Ref+	DAT+	DAT+	DAT+	DAT+	DAT+	Zero+	SD+	Zero+
7	COM-	COM-	R2 Ref-	DAT-	DAT-	DAT-	DAT-	DAT-	Zero-	SD-	Zero-
8	-	-	Thermal control (PTC)								
9	-	-	Thermal control (PTC, GND)								
10	+5V	+5V	-	+5V	+5V	+5V	+5V	+8 to +9V	+5V	+5V	+5V
11	0V	0V	-	0V	0V	0V	0V	0V	0V	0V	0V
12	-	-	S1 SIN+	A+	-	A+	-	SIN+	A+	-	A+
13	-	-	S3 SIN-	A-	-	A-	-	SIN-	A-	-	A-
14	-	-	S2 COS+	B+	-	B+	-	COS+	B+	-	B+
15	-	-	S4 COS-	B-	-	B-	-	COS-	B-	-	B-

CLK = CLOCK, DAT = DATA, SEN = SENSE

8.11.2 Resolver

The diagram below shows the connection of a resolver (2 to 36-poles) as a feedback system. The thermal control in the motor is connected via the Resolver cable and evaluated in the drive. If no thermal control is in the motor, the cable must short pins 8 and 9.

If cable lengths of more than 100 m are planned, please contact customer support.

Type	FCTYPE	Description
Resolver	40	Accuracy: 14 bit (0.022°), resolution: 16 bit (0.006°)

The pin assignment shown on the resolver side relates to Kollmorgen motors.

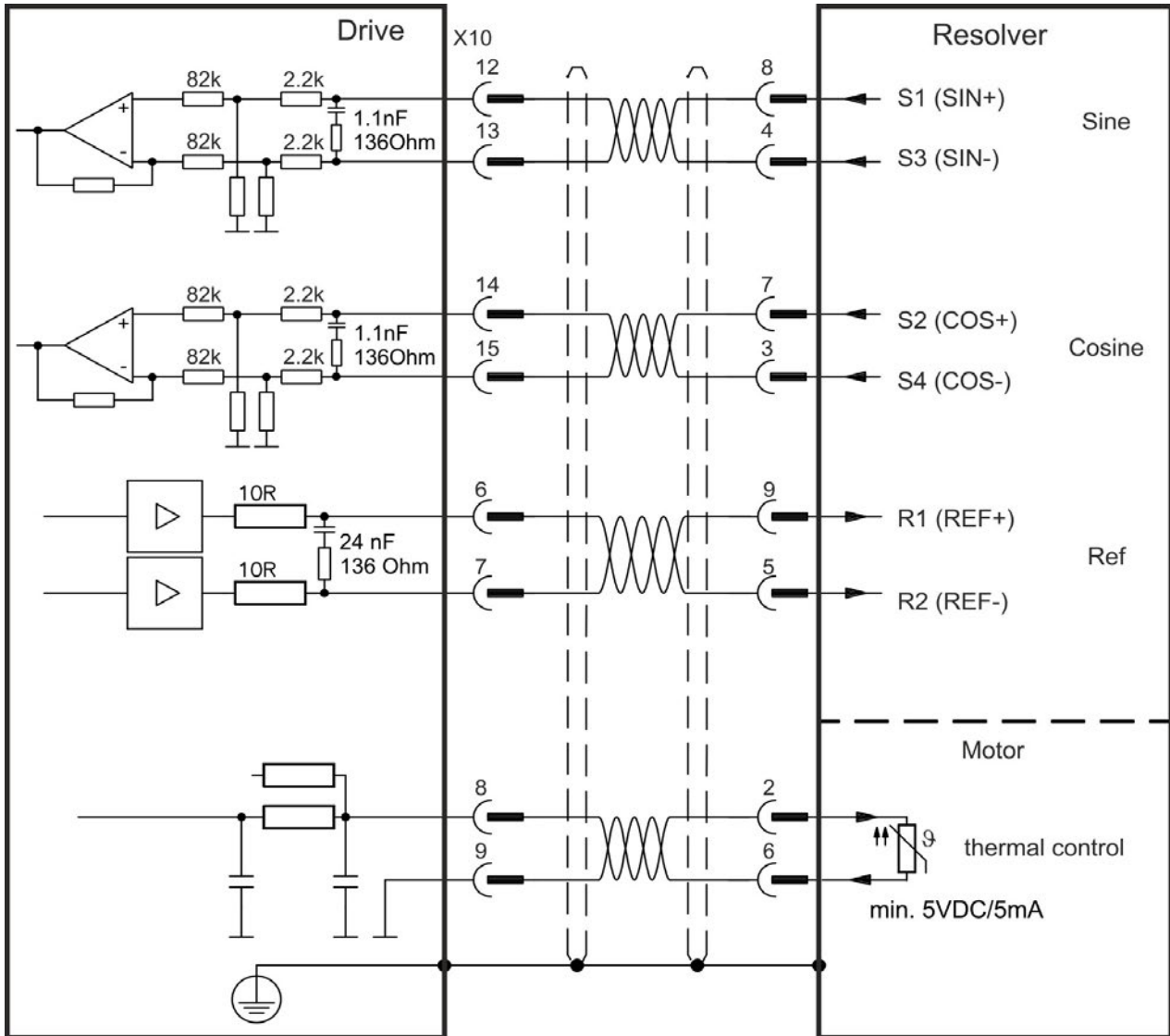

8.11.3 SFD

The diagram below shows the connection of the four wire Kollmorgen SFD feedback system.

NOTE

When SFD cable total resistance for 5V out (Up) and 5V return (0V) is less than 3.3 Ohm, then remote sensing is not needed. For typical cable this means remote sensing is not needed up to 25 m.

Kollmorgencables are rated up to 50 m with no remote sensing.

Type	FBTYPE	Up	Remarks
Smart Feedback Device (SFD)	41	5.1 V +/-5%	accuracy 14 bit (0.022°), resolution 24 bit (2 x 10E-5°)

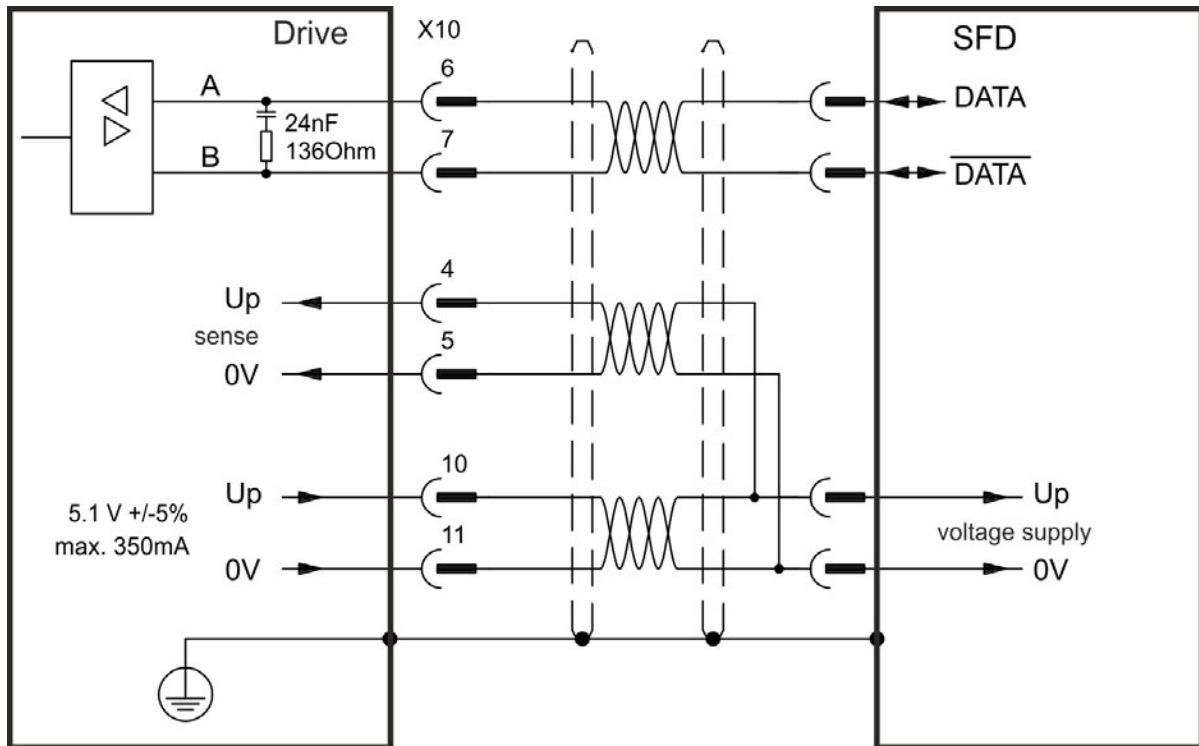

8.11.4 SFD3

The diagram below shows the connection of the two wire Kollmorgen SFD3 feedback system.

NOTE

SFD3 can be used with the special Kollmorgen cable.
Maximum cable length is up to 25 m.

Type	FBTYP	Up	Remarks
SFD3	45	8 to 9 V	from FW 1.11, with Kollmorgen Cables only

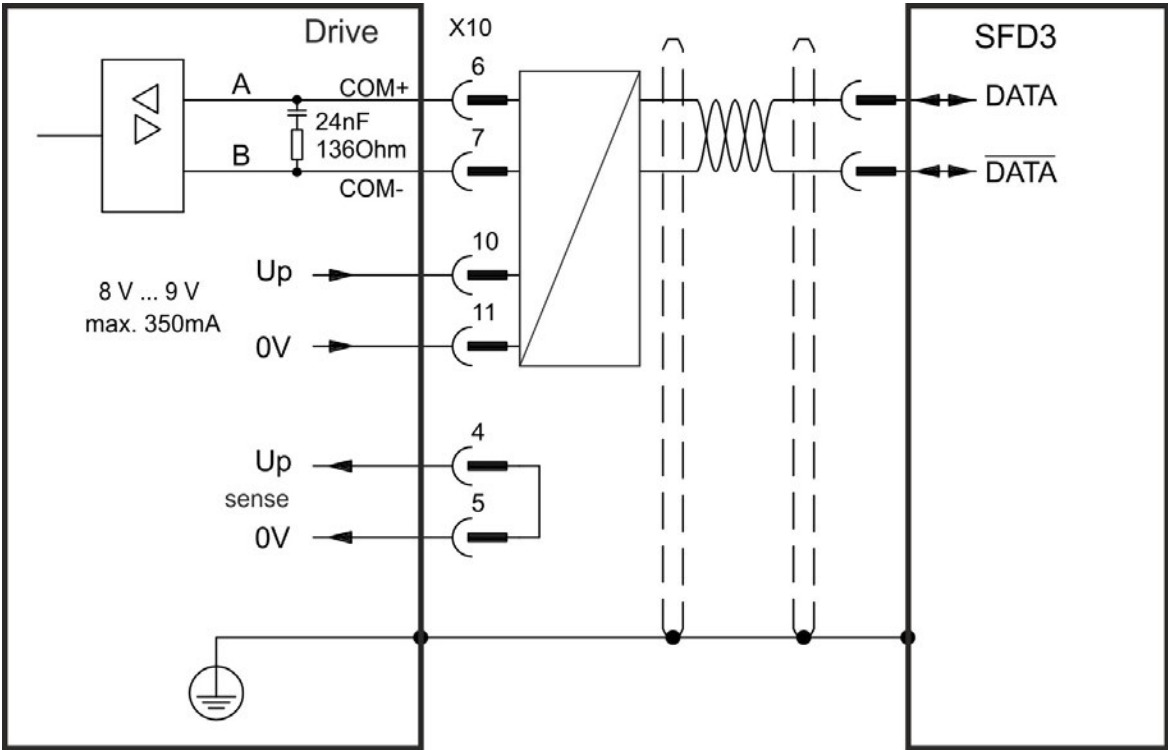

8.11.5 Hiperface DSL

The diagram below shows the connection of the two wire Hiperface DSL feedback system.

NOTE

Hiperface DSL can be used with the special Kollmorgen cable.
Maximum cable length is up to 25 m.

Type	FCTYPE	Up	Remarks
Hiperface DSL	46	8 to 9 V	from FW 1.9, with Kollmorgen Cables only

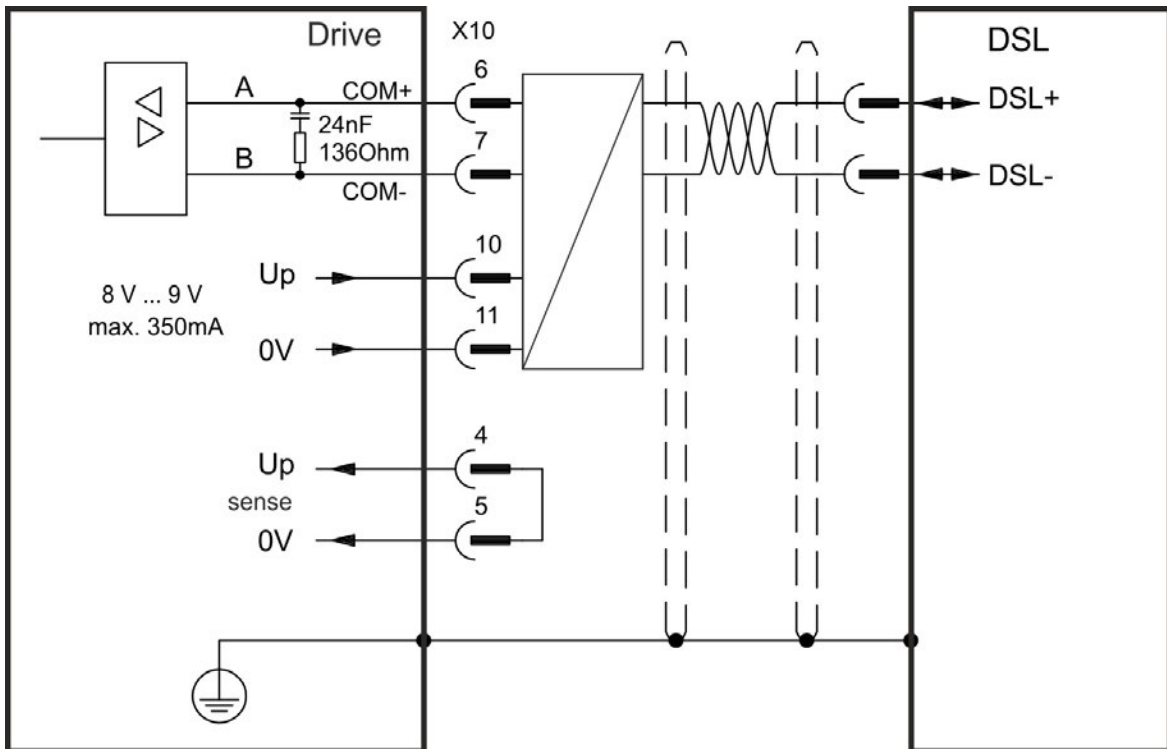

8.11.6 Encoder with BiSS

8.11.6.1 BiSS (Mode B) analog

The diagram below shows the wiring of a single-turn or multi-turn encoder with BiSS Mode B interface as a feedback system. The thermal control in the motor is connected via the encoder cable and evaluated in the drive.

If cable lengths of more than 50 m are planned, please consult customer support.

Type	FBTYP	Up	Frequency Limit
BiSS (Mode B) Analog	32	5.1 V +/-5%	1 MHz, 250 kHz for encoders that require termination resistors

The pin assignment shown on the encoder side relates to Kollmorgen motors.

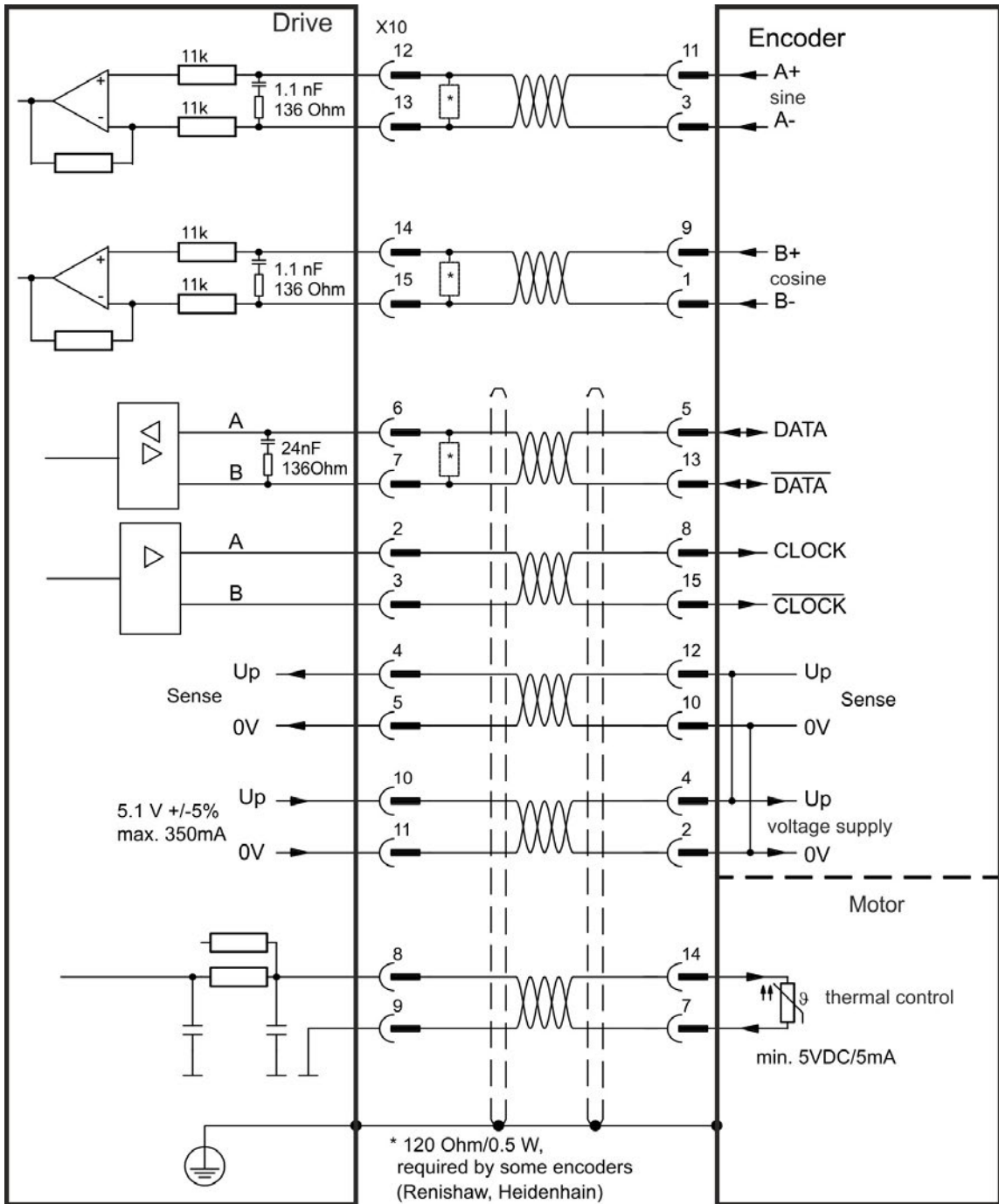

8.11.6.2 BiSS (Mode C) digital

The diagram below shows the wiring of a single-turn or multi-turn encoder with BiSS Mode C interface from Renishaw (specifically model Resolute RA26B) as a feedback system. The thermal control in the motor is connected via the encoder cable and evaluated in the drive.

If cable lengths of more than 25 m are planned, please consult customer support.

Type	FCTYPE	Up	Frequency Limit
BiSS Mode C	34	5.1 V +/-5%	2.5 MHz

The pin assignment shown on the encoder side relates to Kollmorgen motors.

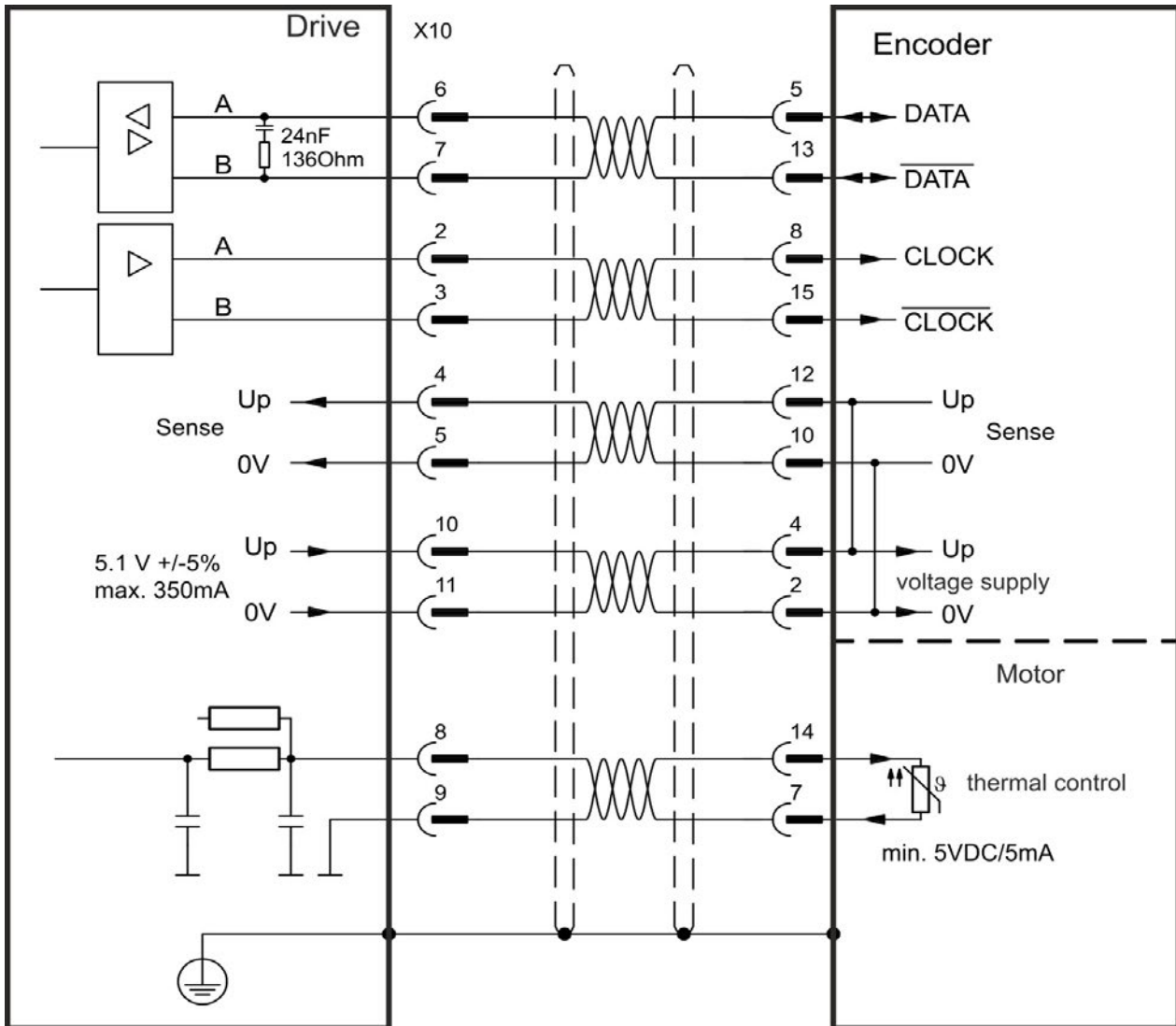

8.11.7 Sine Encoder with EnDat 2.1

The diagram below shows the wiring of a single-turn or multi-turn sine-cosine encoder with EnDat 2.1 interface as a feedback system. Preferred types are the ECN1313 and EQN1325 encoders. The thermal control in the motor is connected via the encoder cable and evaluated in the drive. All signals are connected using our pre-assembled encoder connection cable. If cable lengths of more than 50 m are planned, consult customer support.

Type	FATYPE	Frequency Limit
ENDAT 2.1	30	1 MHz, 250 kHz for encoders that require termination resistors

The pin assignment shown on the encoder side relates to Kollmorgen motors.

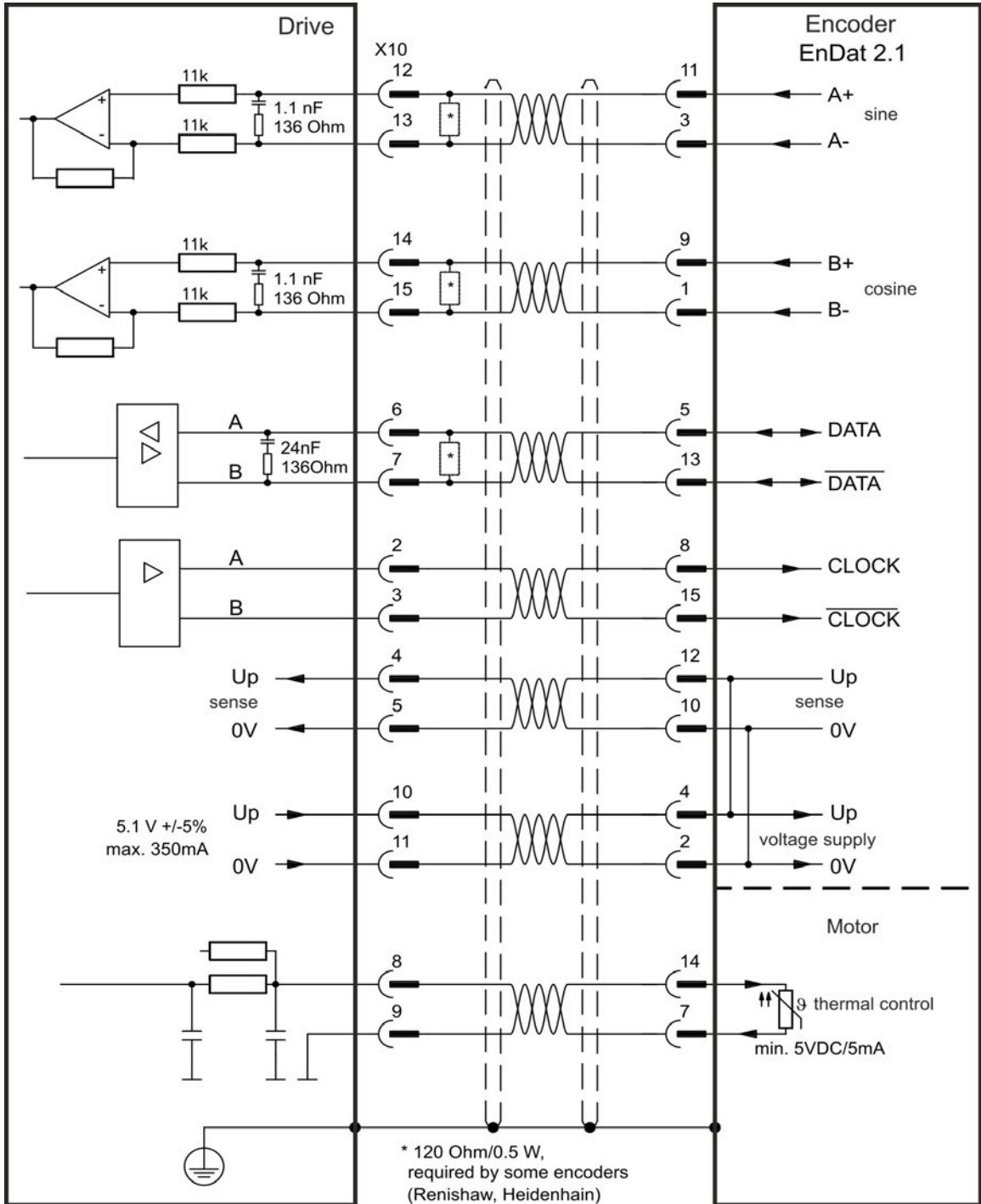

8.11.8 Encoder with EnDat 2.2

The table and figure below describe wiring of a single-turn or multi-turn encoder with EnDat 2.2 interface as a feedback system.

The thermal control in the motor is connected via the encoder cable and evaluated in the drive. All signals are connected using our pre-assembled encoder connection cable. If cable lengths of more than 50 m are planned, please consult customer support.

Type	FATYPE	Frequency Limit	Description
ENDAT 2.2	31	1 MHz	Adjust on screen page FEEDBACK

The pin assignment shown on the encoder side relates to Kollmorgen motors.

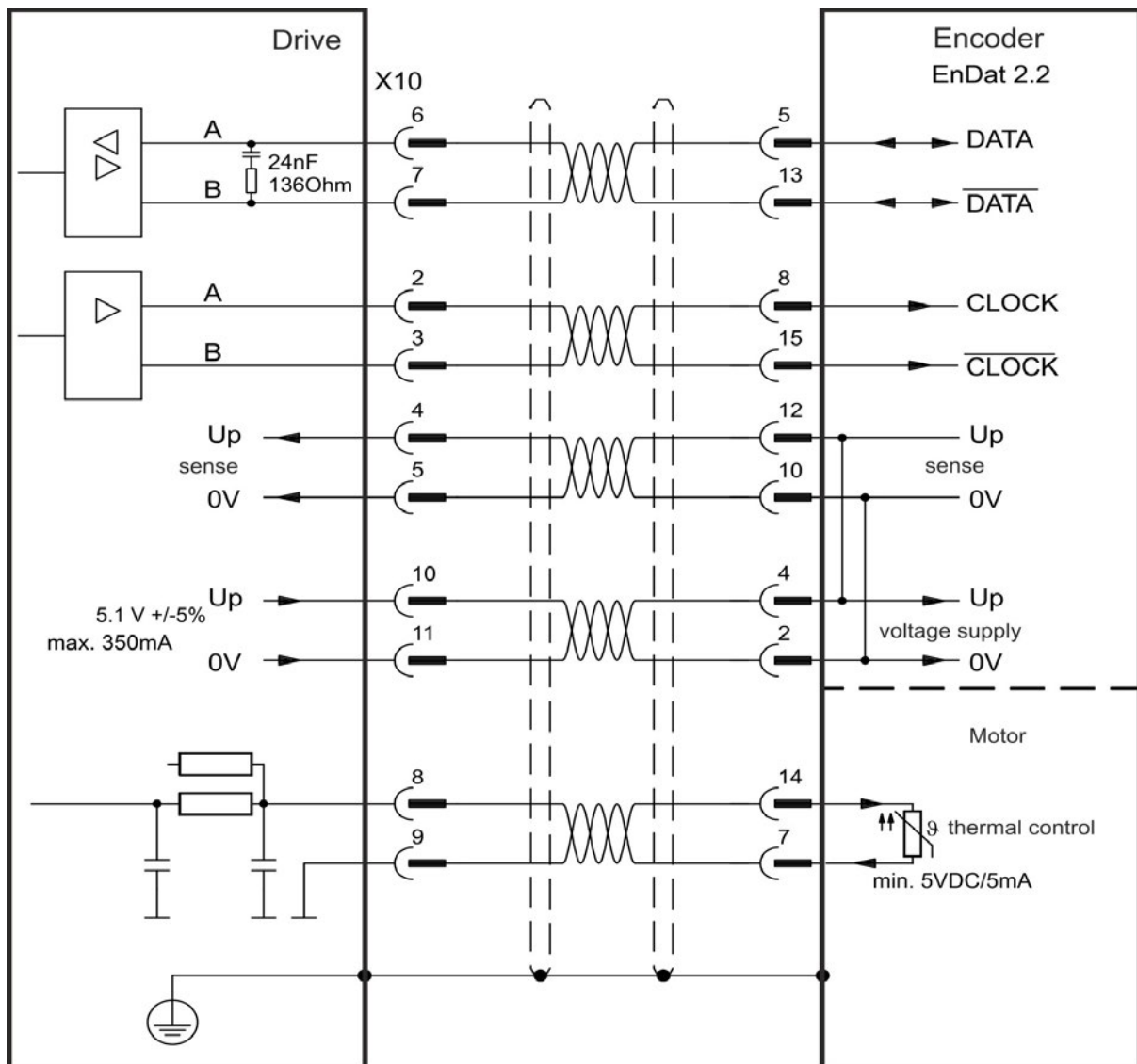

8.11.9 Sine Encoder with Hiperface

The diagram below shows the wiring of a single-turn or multi-turn sine-cosine encoder with Hiperface interface as a feedback system.

The thermal control in the motor is connected via the encoder cable and evaluated in the drive. All signals are connected using our pre-assembled encoder connection cable.

If cable lengths of more than 50 m are planned, please consult customer support.

Type	FBTYP	Frequency Limit	Description
Hiperface	33	1 MHz, 250 kHz for encoders that require termination resistors	Connecting pin 4 and 5 together causes Up to be 8 to 9 V

The pin assignment shown on the encoder side relates to Kollmorgen motors.

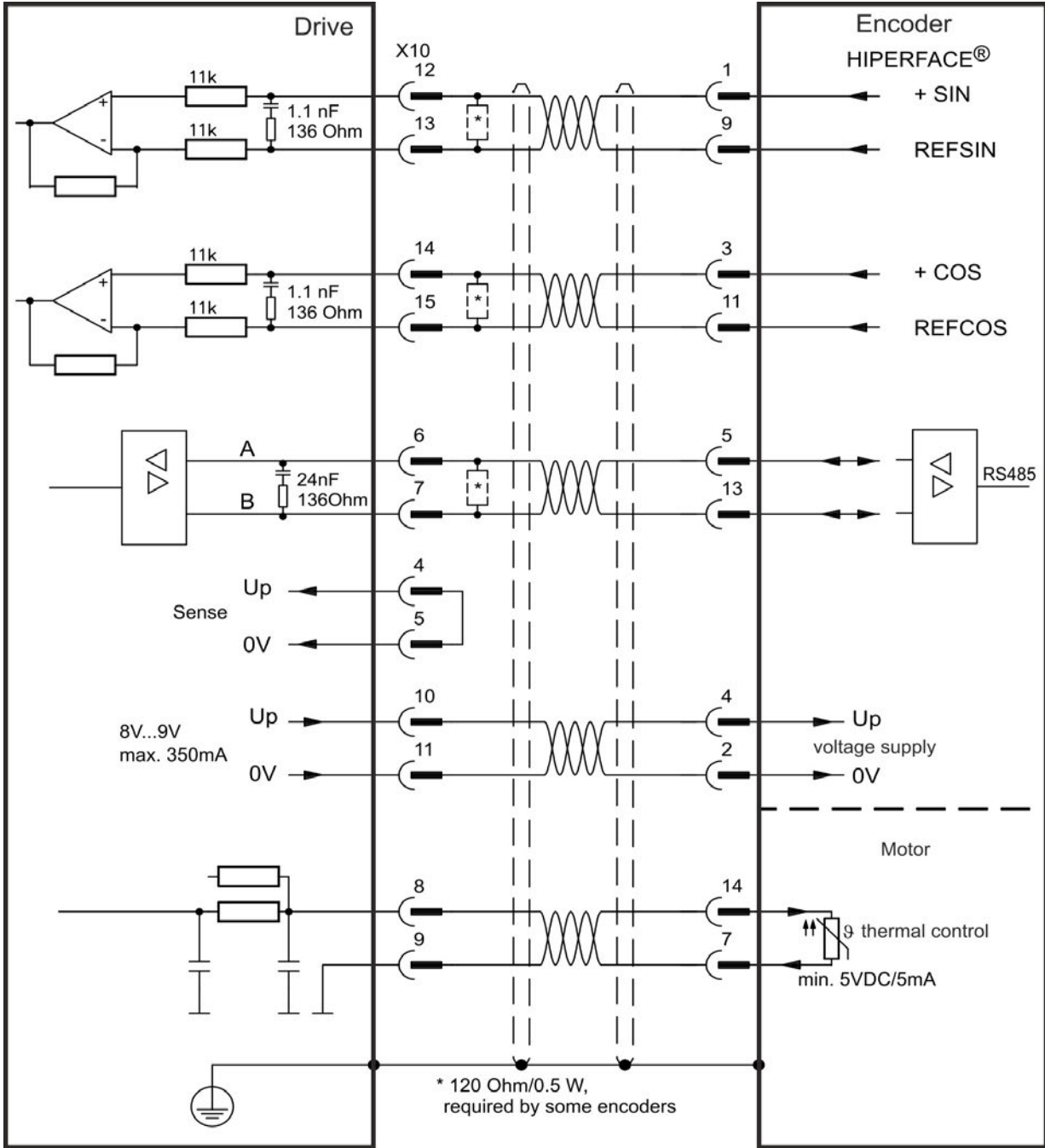

8.11.10 Sine Encoder

Feedback devices, which do not deliver absolute information for commutation, can either work with wake&shake commutation (see *AKD User Guide*) or can be used as a complete feedback system when combined with an additional Hall encoder. All signals are connected to X10 and evaluated there. If cable lengths of more than 25 m are planned, please consult customer support.

Type	FBTYP E	Up	Frequency Limit
SinCos 1 V p-p with Hall	20	5.1 V +/-5%	1 MHz, 250 kHz for encoders that require termination resistors
SinCos 1 V p-p (Wake&Shake)	21	5.1 V +/-5%	

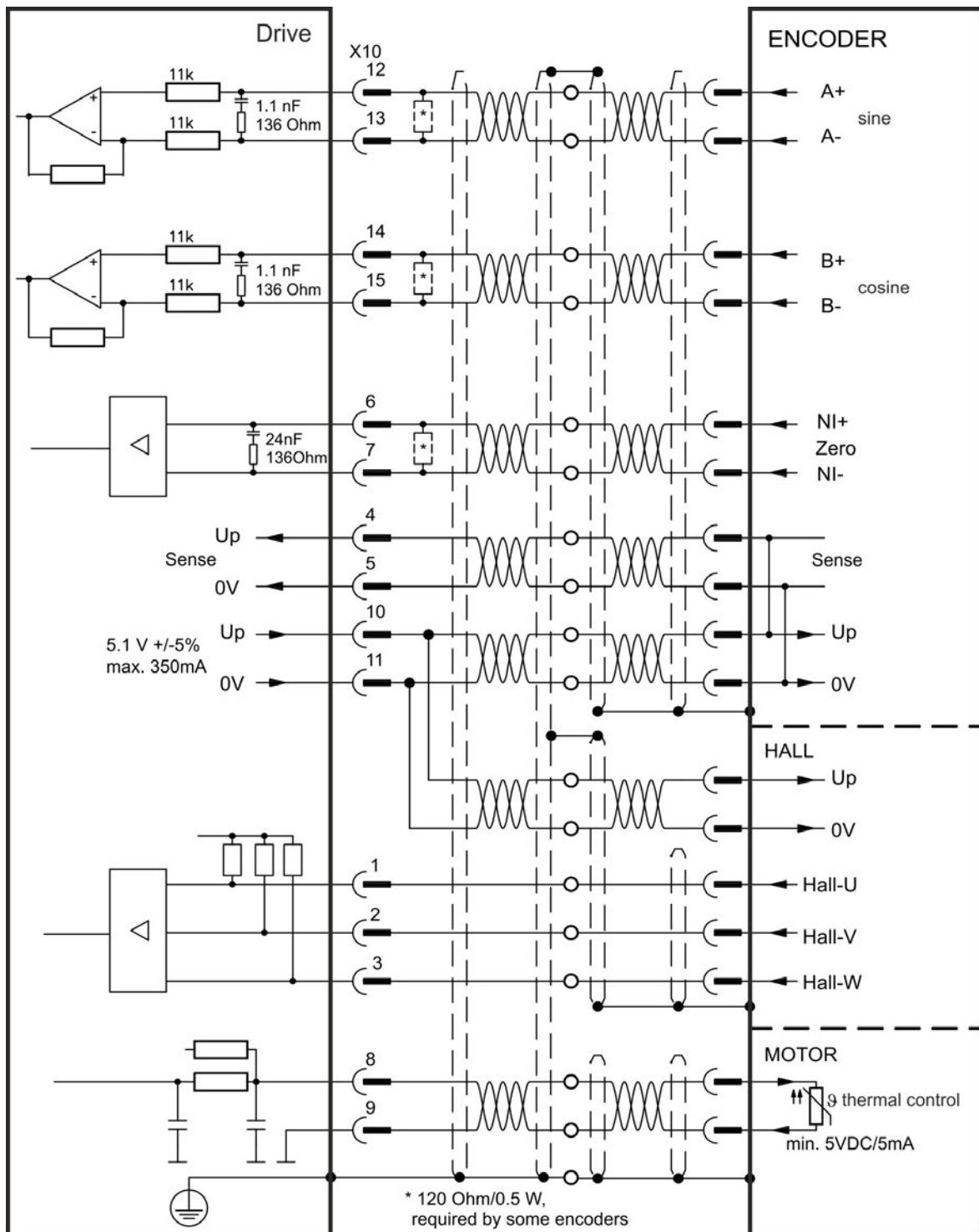

8.11.11 Incremental Encoder

Feedback devices, which do not deliver absolute information for commutation, can either work with wake&shake commutation (see *AKD User Guide*) or can be used as a complete feedback system when combined with an additional Hall encoder. All signals are connected using a pre-assembled comcoder connection cable. The thermal control in the motor is connected via the encoder cable and evaluated in the drive.

If cable lengths of more than 25 m are planned, please consult customer support.

Type	FBTYP	Frequency Limit
Incremental Encoder&Hall Switches (Comcoder)	10	2.5 MHz
Incremental Encoder (Wake&Shake)	11	2.5 MHz

The pin assignment shown on the encoder side relates to Kollmorgen motors.

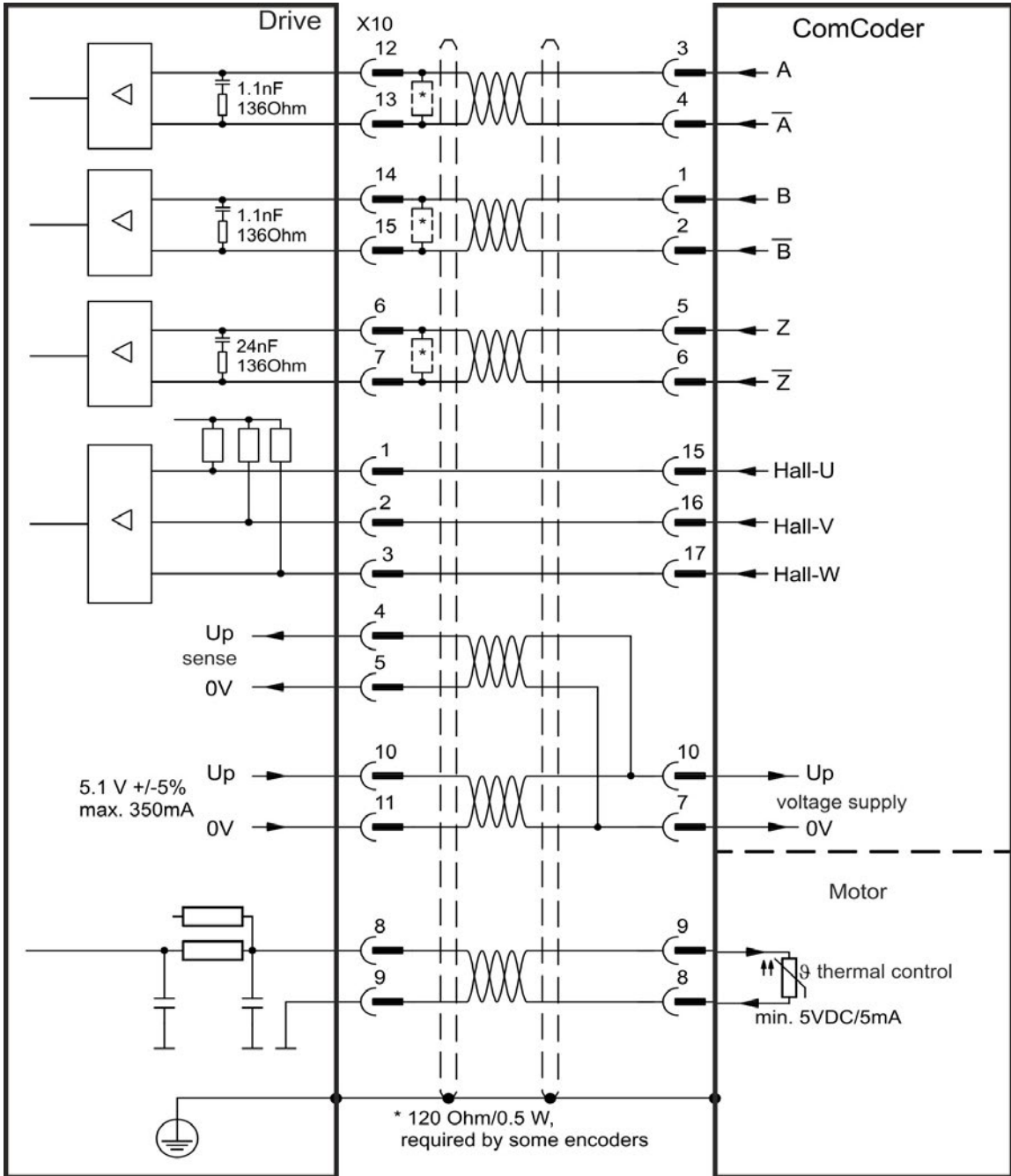

8.11.12 Tamagawa Smart Abs Encoder

The diagram below shows the wiring of Tamagawa "Smart Abs" encoders (Tamagawa Seiki Co. Ltd. S48-17/33bit-LPS-5V or similar) as a primary feedback system. The thermal control in the motor is connected via the encoder cable and evaluated in the drive. If no thermal control is in the motor, the cable must short pins 8 and 9. The "Sense" signal is optional, and can be omitted if the encoder cable is short and no significant voltage drop is on the cable. The voltage drop depends on the cable length and gage and the encoder current consumption.

If cable lengths of more than 25 m are planned, please consult customer support.

Type	FbTYPE	Up	Frequency Limit
S48-17/33bit-LPS-5V	42	5.1 V +/-5%	2.5 MHz

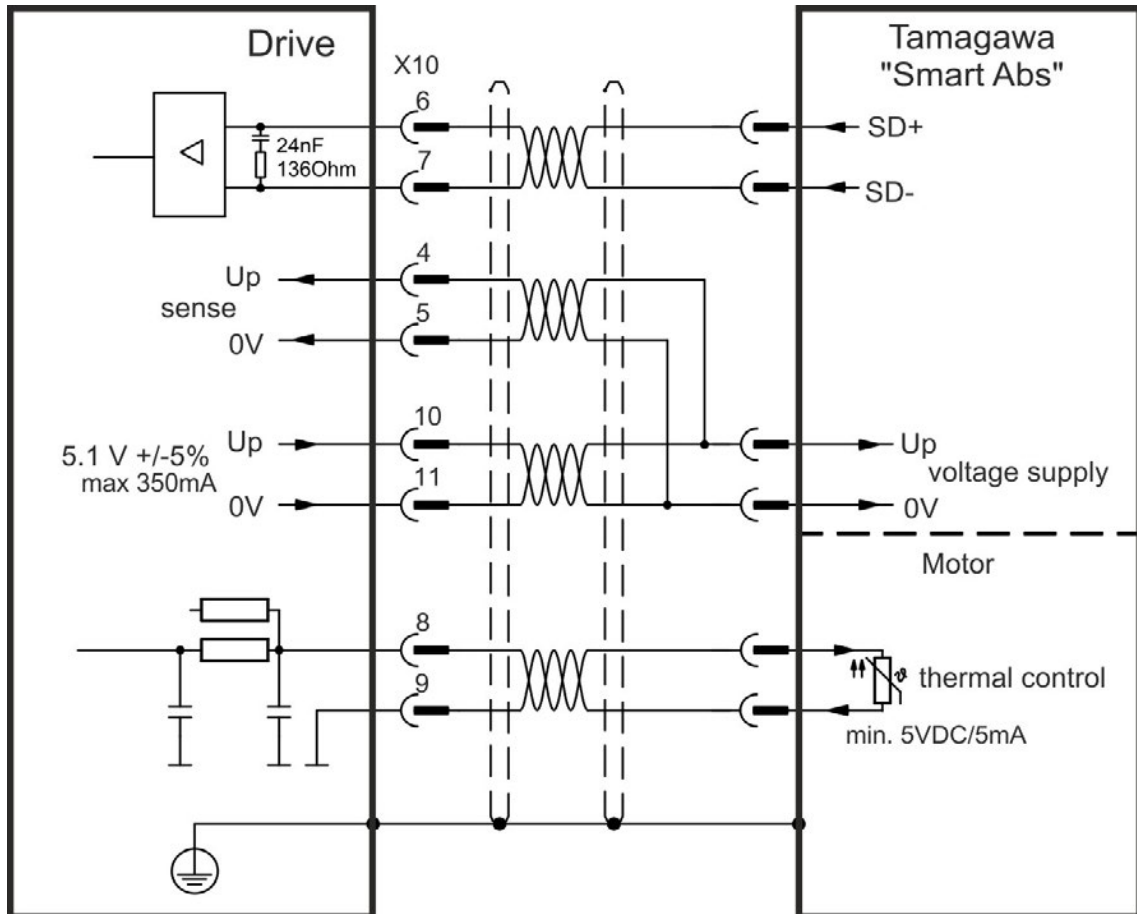

8.12 Electronic gearing, Master-slave operation

It is possible to set up master/slave systems, use an external encoder as a command encoder, secondary feedback device (dual loop control) or connect the amplifier to a third party step controller. Depending on the signal voltage level connector X9 (5 V TTL) or X7 (24 V) must be used.

The WorkBench setup software is used for configuration. See the “Feedback 2” screen in WorkBench for setup. FB2.SOURCE, FB2.MODE, FB2.ENCRE and others are used for setting up an application with these interfaces.

Connector X9 can be configured as an input or as an output for 5 V (TTL level) signals.

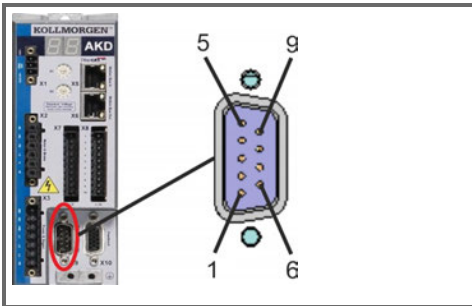
	Input modes X9	Output mode
	Pulse & Direction, 5 V	Emulated Encoder Output (A quad B), 5 V
	Up/Down, 5 V	
	Incremental Encoder (A quad B), 5 V	
	Encoder with EnDat 2.2, 5 V	

Connector X7, DIGITAL-IN 1/2 can be configured as an input for 24 V signals.

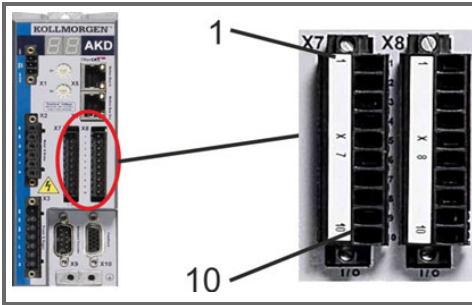
	Input modes X7 DIGITAL-IN 1/2	Output mode
	Pulse & Direction, 24 V	
	Up/Down, 24 V	
	Incremental Encoder (A quad B), 24 V	

8.12.1 Technical characteristics and pinout

8.12.1.1 Connector X7 Input

Technical characteristics

- Floating, reference common line is DCOM7
- Maximum signal input frequency: 500 kHz
- Sink or Source type connection possible
- High: 15 to 30 V/2 to 15 mA , Low: -3 to 5 V/<15 mA
- Update rate: Hardware 2 μs

Pin	Pulse/Direction	Up/Down	Incremental Encoder
9	Pulse	Up (CW)	Channel A
10	Direction	Down (CCW)	Channel B
1	Common	Common	Common

8.12.1.2 Connector X9 Input

Technical characteristics

- Electrical interface: RS-485
- Maximum signal input frequency: 3MHz
- Input signal voltage range: +12 V to -7 V
- Supply voltage (only applicable to Incremental Encoder Input): +5 V \pm 5%
- Maximum supply current: 250 mA

Pin	Pulse/Direction	Up/Down	Incremental Encoder	Encoder with EnDat 2.2
1	Pulse+	Up+	A+	CLOCK+
2	Pulse-	Up-	A-	CLOCK-
3	GND	GND	GND	GND
4	Direction+	Down+	B+	DATA+
5	Direction-	Down-	B-	DATA-
6	Shield	Shield	Shield	Shield
7	-	-	Zero+	-
8	-	-	Zero-	-
9	-	-	+ 5 V (supply, output)	+5V (supply, output)

NOTICE

Maximum cable length of an external incremental encoder using X9 is dependant on cable voltage drop and external encoder power requirements. See the calculation example in the user guide's chapter "Electronic Gearing".

8.12.1.3 Connector X9 Output

Technical characteristics

- Electrical Interface: RS-485
- Max frequency: 3 MHz
- Resolution: Up to 16 bit
- The pulses per revolution value are settable
- Pulse phase shift: $90^{\circ} \pm 20^{\circ}$

Pin	Emulated Encoder Output
1	Channel A+
2	Channel A-
3	GND
4	Channel B+
5	Channel B-
6	Shield
7	Channel Zero+
8	Channel Zero-
9	-

NOTE

The maximum permissible cable length is 100 meters.

8.12.2 Command encoder signal connection

8.12.2.1 Incremental encoder input 5 V (X9)

A 5 V A quad B encoder, or the encoder emulation output of another drive can be connected to this input and used as a commander encoder, dual loop feedback, gearing or camming input. Don't use for primary motor feedback connection!

Connection Diagram

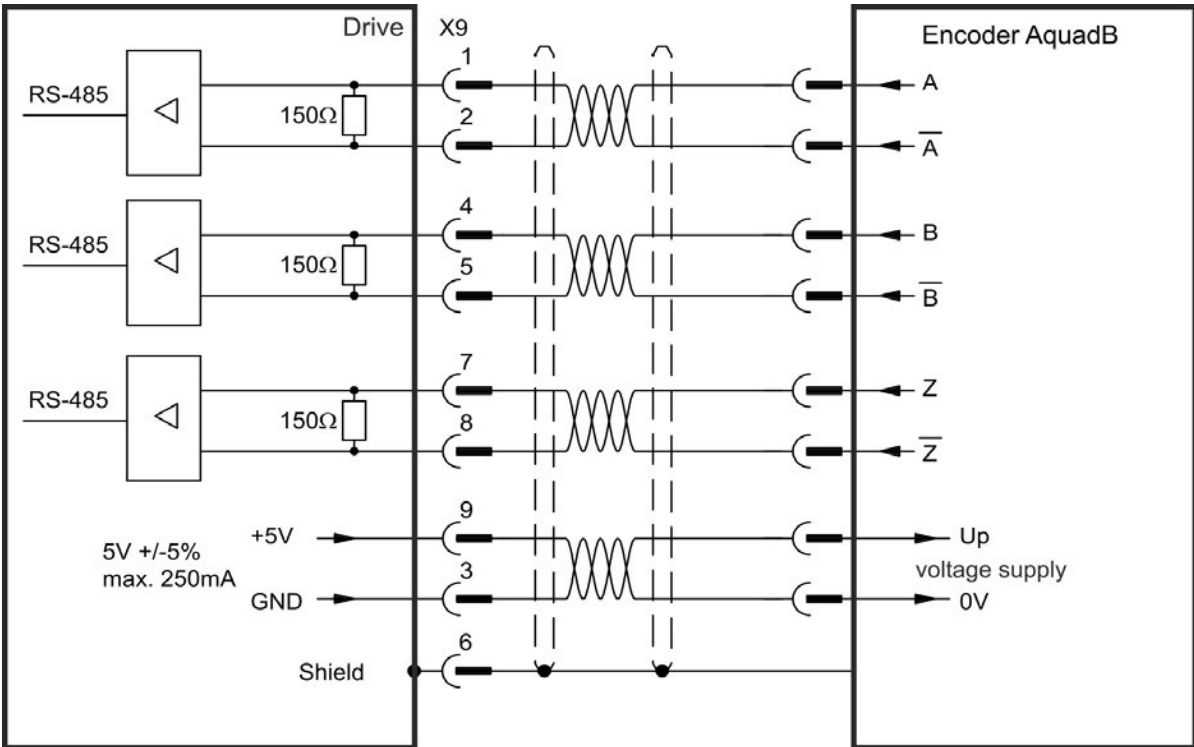

8.12.2.2 Incremental encoder input 24 V (X7)

A 24 V A quad B encoder can be connected to the digital inputs 1 and 2 and used as a commander encoder, dual loop feedback, gearing or camming input. Don't use for primary motor feedback connection!

Connection Diagram

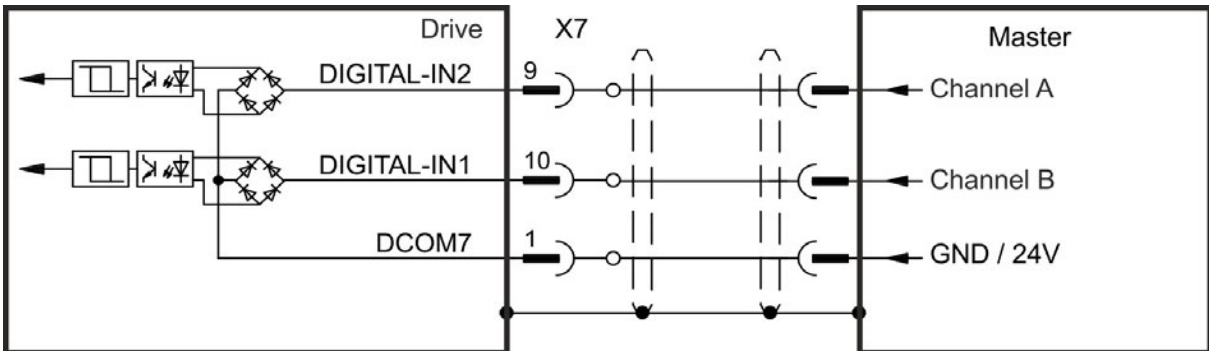

8.12.2.3 Encoder with EnDat 2.2 input 5 V (X9)

A single-turn or multi-turn encoder with EnDat 2.2 can be connected to this input and used as a commander encoder, dual loop feedback, gearing or camming input. Don't use for primary motor feedback connection!

Connection Diagram

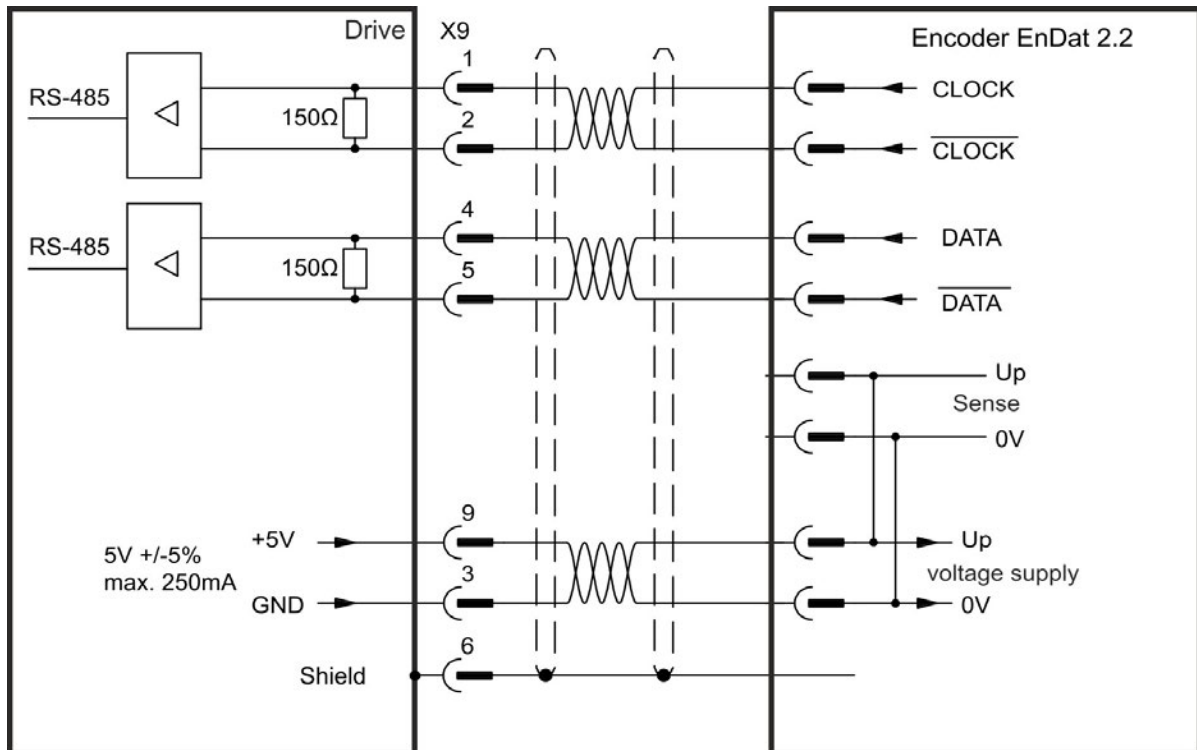

8.12.3 Pulse / Direction signal connection

The drive can be connected to a stepper-motor controller. Set parameters for the drive with WorkBench. The number of pulses can be adjusted, so that the drive can be adapted to match any stepper controller.

Speed profile and signal diagram

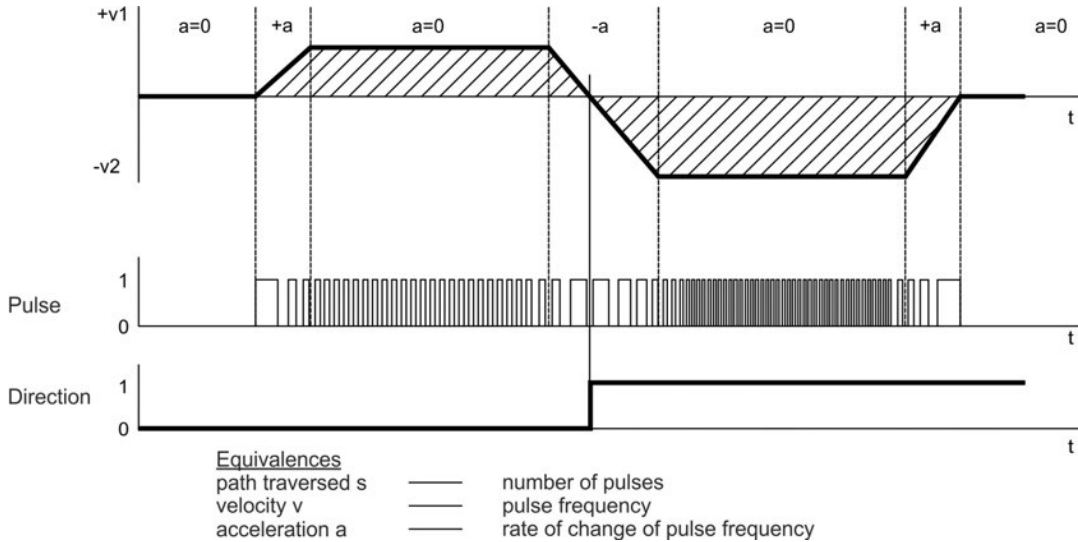

8.12.3.1 Pulse / Direction input 5 V (X9)

Connection to 5 V signal level stepper-motor controllers.

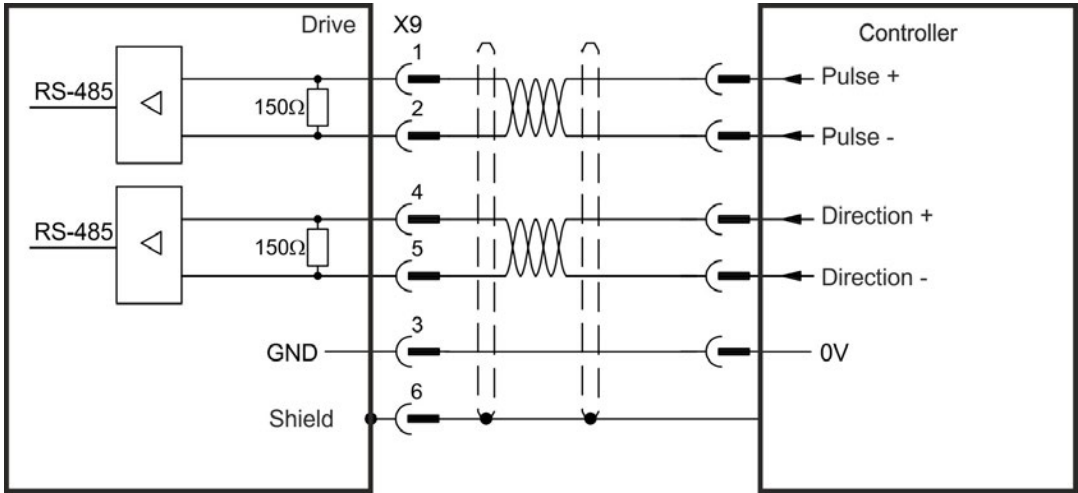

8.12.3.2 Pulse / Direction Input 5V (X7)

Connection industry standard 5V logic stepper-motor controllers with Pulse/Direction or Step/Direction outputs. Note that the X7 opto inputs can work with 5V up to 24V logic and so these inputs can be driven by 24V logic inputs as well.

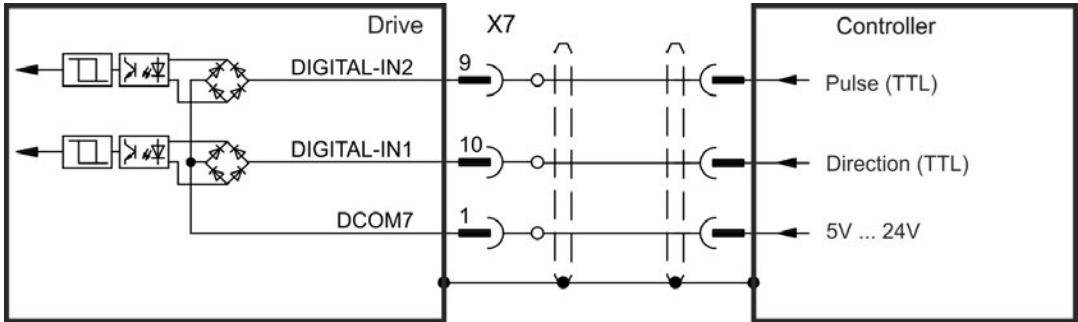

8.12.4 Up / Down signal connection

8.12.4.1 Up / Down input 5 V (X9)

The drive can be connected to a third-party controller which delivers 5 V up-down signals

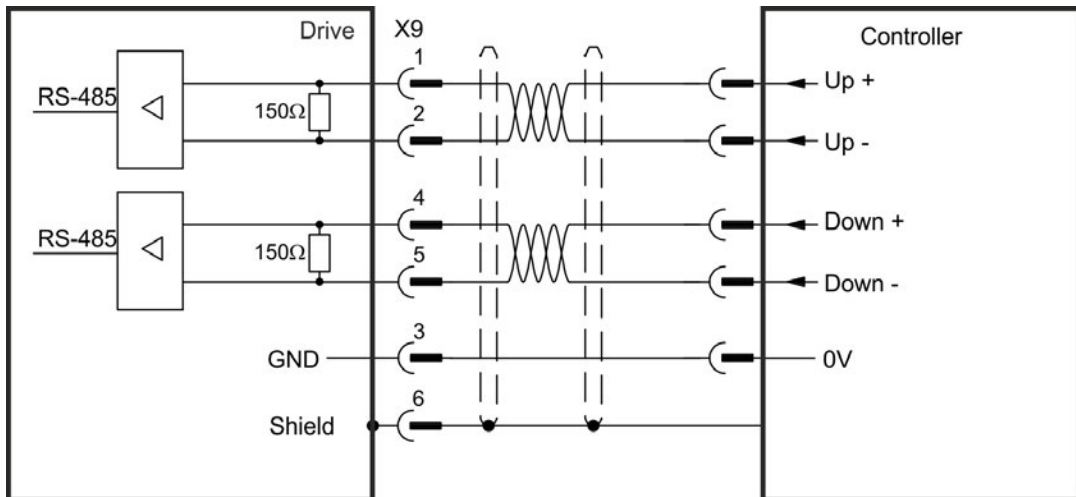

8.12.4.2 Up / Down input 24 V (X7)

The drive can be connected to a third-party controller which delivers 24 V up-down signals.

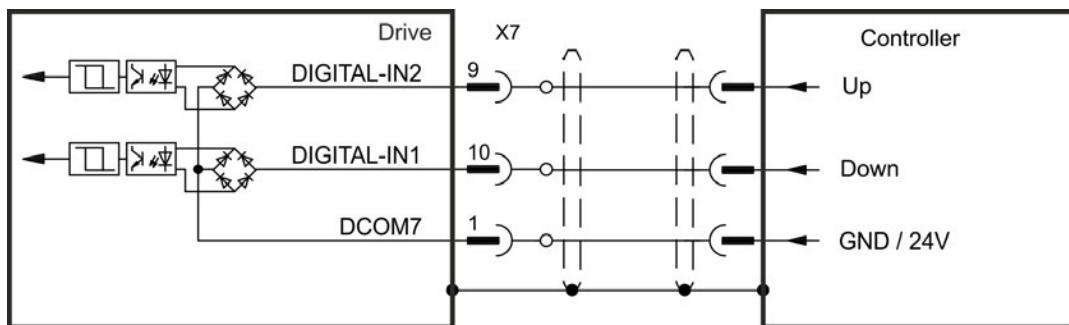

8.12.5 Emulated Encoder Output (EEO)

The drive calculates the motor shaft position from the cyclic- absolute signals of the primary feedback, generating incremental-encoder compatible pulses from this information. Pulse outputs on the SubD connector X9 are 3 signals, A, B and Index, with 90° phase difference (i.e. in quadrature, hence the alternative term "A quad B" output), with a zero pulse. The resolution (before multiplication) can be set by the DRV.EMUERES parameter. Use the DRV.EMUEZOFFSET parameter to adjust + save the zero pulse position within one mechanical turn. The drivers operate from an internal supply voltage.

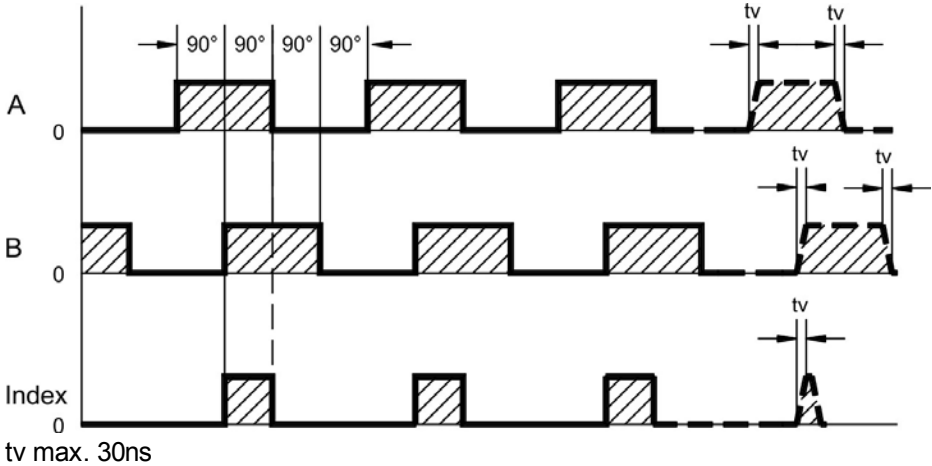

Connection Diagram

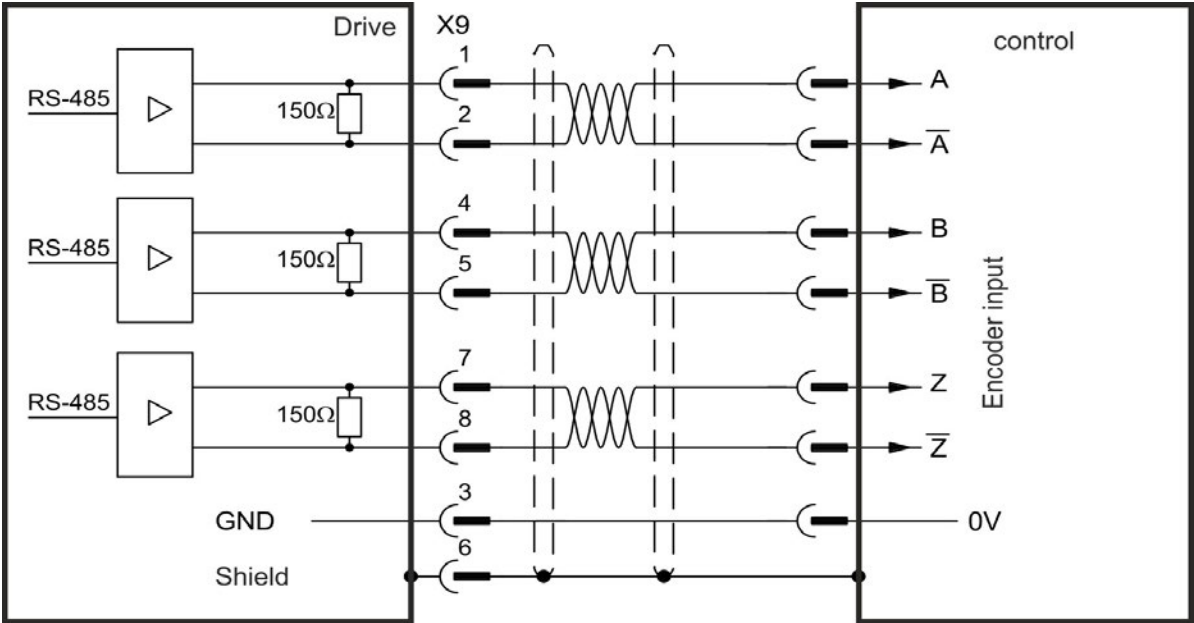

8.12.6 Master-Slave control

Several AKD can be connected as slave drives to an AKD master. The slave drives use the master's encoder output signals as command input and follow these commands (velocity and direction).

Master-Slave Connection Diagram, example for 5V signal level (X9)

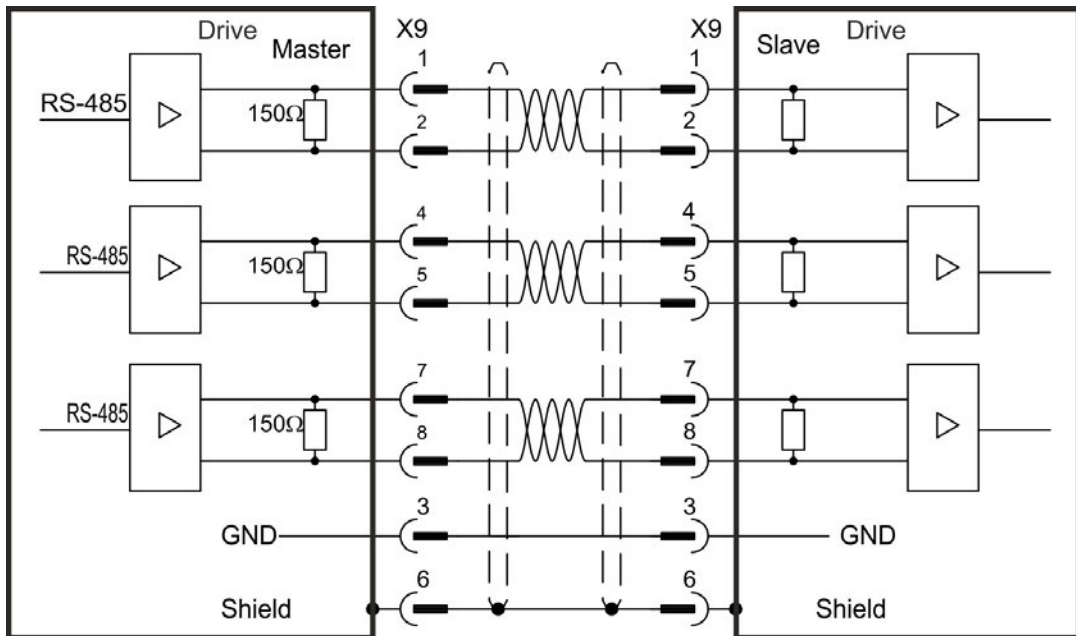

8.13 I/O Connection

8.13.1 I/O connectors X7 and X8 (all AKD variants)

Standard digital and analog I/O signals are connected to X7 and X8.

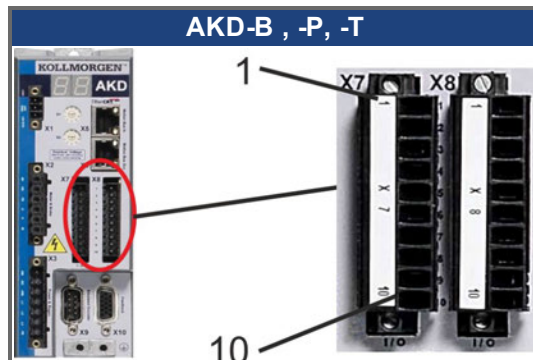

Conn.	Pin	Signal	Abbreviation	Function	Wiring Diagram
X7	1	Digital Common X7	DCOM7	Common line for X7 pins 2, 3, 4, 9, 10	→ p. 131
X7	2	Digital Input 7	DIGITAL-IN 7	Programmable	
X7	3	Digital Input 4	DIGITAL-IN 4	Programmable	
X7	4	Digital Input 3	DIGITAL-IN 3	Programmable	
X7	5	Digital Output 2-	DIGITAL-OUT2-	Programmable	→ p. 134
X7	6	Digital Output 2+	DIGITAL-OUT2+	Programmable	
X7	7	Digital Output 1-	DIGITAL-OUT1-	Programmable	
X7	8	Digital Output 1+	DIGITAL-OUT1+	Programmable	
X7	9	Digital Input 2	DIGITAL-IN 2	Programmable,fast	→ p. 131
X7	10	Digital Input 1	DIGITAL-IN 1	Programmable,fast	
X8	1	Fault Relay Output	Fault Relay Output	Fault Relay Output	→ p. 135
X8	2	Fault Relay Output	Fault Relay Output	Fault Relay Output	
X8	3	Digital Common X8	DCOM8	Common line for X8 pins 4, 5, 6	→ p. 131
X8	4	Digital Input 8	DIGITAL-IN 8	Output stage enable, not programmable	
X8	5	Digital Input 6	DIGITAL-IN 6	Programmable	
X8	6	Digital Input 5	DIGITAL-IN 5	Programmable	
X8	7	Analog Ground	AGND	Analog GND	→ p. 130
X8	8	Analog Output +	Analog-Out	Actual velocity voltage	
X8	9	Analog Input -	Analog-In-	Velocity set point	→ p. 129
X8	10	Analog Input +	Analog-In+		

Digital common lines for X7 and X8 are not common to each other.

The DCOMx line should be connected to the 0V of the I/O supply when using sensors of type "Source" with digital inputs.

The DCOMx line should be connected to the 24V of the I/O supply when using sensors of type "Sink" with digital inputs.

8.13.2 I/O connectors X21, X22, X23 and X24 (AKD-T with I/O option card only)

The I/O option card offers four additional connectors X21, X22, X23, X24 for I/O signals.

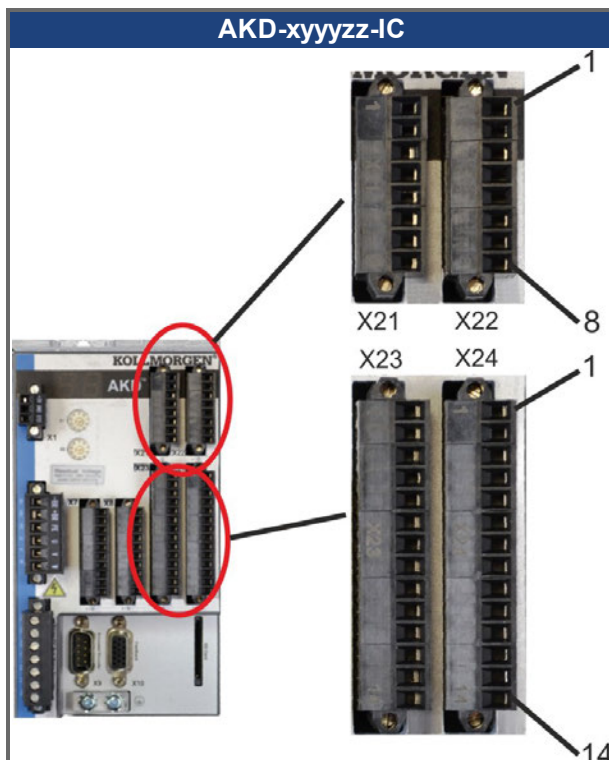

Conn.	Pin	Signal	Abbreviation	Function	Wiring Diagram
X21	1	Digital Input 21	DIGITAL-IN 21	Programmable	→ p. 136
X21	2	Digital Input 22	DIGITAL-IN 22	Programmable	
X21	3	Digital Input 23	DIGITAL-IN 23	Programmable	
X21	4	Digital Common X21/1_3	DCOM21.1_3	Common line for X21 pins 1, 2, 3	
X21	5	Digital Input 24	DIGITAL-IN 24	Programmable	
X21	6	Digital Input 25	DIGITAL-IN 25	Programmable	
X21	7	Digital Input 26	DIGITAL-IN 26	Programmable	
X21	8	Digital Common X21/5_7	DCOM21.5_7	Common line for X21 pins 5, 6, 7	
X22	1	Digital Input 27	DIGITAL-IN 27	Programmable	→ p. 136
X22	2	Digital Input 28	DIGITAL-IN 28	Programmable	
X22	3	Digital Input 29	DIGITAL-IN 29	Programmable	
X22	4	Digital Common X22/1_3	DCOM22.1_3	Common line for X22 pins 1, 2, 3	
X22	5	Digital Input 30	DIGITAL-IN 30	Programmable	
X22	6	Digital Input 31	DIGITAL-IN 31	Programmable	
X22	7	Digital Input 32	DIGITAL-IN 32	Programmable	
X22	8	Digital Common X22/5_7	DCOM22.5_7	Common line for X22 pins 5, 6, 7	

Conn.	Pin	Signal	Abbreviation	Function	Wiring Diagram
X23	1	Analog Output 2 +	Analog-Out2	Programmable	→ p. 130
X23	2	reserved	n.c.	n.c.	
X23	3	Analog Ground	AGND	Programmable	
X23	4	reserved	n.c.	n.c.	
X23	5	Digital Output 21+	DIGITAL-OUT 21+	Programmable	→ p. 138
X23	6	Digital Output 21-	DIGITAL-OUT 21-	Programmable	
X23	7	Digital Output 22+	DIGITAL-OUT 22+	Programmable	
X23	8	Digital Output 22-	DIGITAL-OUT 22-	Programmable	
X23	9	Digital Output 23+	DIGITAL-OUT 23+	Programmable	
X23	10	Digital Output 23-	DIGITAL-OUT 23-	Programmable	
X23	11	Digital Output 24+	DIGITAL-OUT 24+	Programmable	
X23	12	Digital Output 24-	DIGITAL-OUT 24-	Programmable	
X23	13	Relay Output 25	DIGITAL-OUT 25	Programmable, relay	→ p. 139
X23	14	Relay Output 25	DIGITAL-OUT 25	Programmable, relay	
X24	1	Analog Input 2+	Analog-In2+	Programmable	→ p. 129
X24	2	Analog Input 2-	Analog-In2-	Programmable	
X24	3	Analog Ground	AGND	Programmable	
X24	4	reserved	n.c.	n.c.	
X24	5	Digital Output 26+	DIGITAL-OUT 26+	Programmable	→ p. 138
X24	6	Digital Output 26-	DIGITAL-OUT 26-	Programmable	
X24	7	Digital Output 27+	DIGITAL-OUT 27+	Programmable	
X24	8	Digital Output 27-	DIGITAL-OUT 27-	Programmable	
X24	9	Digital Output 28+	DIGITAL-OUT 28+	Programmable	
X24	10	Digital Output 28-	DIGITAL-OUT 28-	Programmable	
X24	11	Digital Output 29+	DIGITAL-OUT 29+	Programmable	
X24	12	Digital Output 29-	DIGITAL-OUT 29-	Programmable	
X24	13	Relay Output 30	DIGITAL-OUT 30	Programmable, relay	→ p. 139
X24	14	Relay Output 30	DIGITAL-OUT 30	Programmable, relay	

8.13.3 I/O connectors X35 and X36 (AKD-M only)

AKD PDMM offers two additional connectors X35 and X36 for digital I/O signals.

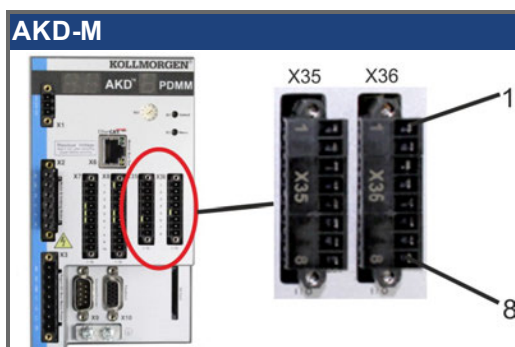

Conn.	Pin	Signal	Abbreviation	Function	Wiring Diagram
X35	1	Digital Common X35	DCOM35	Common line for X35 pins 2, 3, 4	→ p. 140
X35	2	Digital Input 21	DIGITAL-IN 21	Programmable	
X35	3	Digital Input 22	DIGITAL-IN 22	Programmable	
X35	4	Digital Input 23	DIGITAL-IN 23	Programmable	
X35	5	n.c.	n.c.	-	-
X35	6	n.c.	n.c.	-	-
X35	7	Digital Output 21-	DIGITAL-OUT21-	Programmable	→ p. 142
X35	8	Digital Output 21+	DIGITAL-OUT21+	Programmable	
X36	1	Digital Common X36	DCOM36	Common line for X36 pins 2, 3, 4	→ p. 140
X36	2	Digital Input 24	DIGITAL-IN 24	Programmable	
X36	3	Digital Input 25	DIGITAL-IN 25	Programmable	
X36	4	Digital Input 26	DIGITAL-IN 26	Programmable	
X36	5	n.c.	n.c.	-	-
X36	6	n.c.	n.c.	-	-
X36	7	Digital Output 22-	DIGITAL-OUT22-	Programmable	→ p. 142
X36	8	Digital Output 22+	DIGITAL-OUT22+	Programmable	

Digital common lines for X35 and X36 are not common to each other.

The DCOMx line should be connected to the 0V of the I/O supply when using sensors of type "Source" with digital inputs.

The DCOMx line should be connected to the 24V of the I/O supply when using sensors of type "Sink" with digital inputs.

8.13.4 Analog Input (X8, X24)

The drive is fitted with differential inputs for analog torque, velocity, or position control. The standard drive offers one analog input on X8, drives with built-in I/O option card offer a second input on X24.

Technical characteristics

- Differential input voltage range: ± 12.5 V
- Maximum input voltage referring to I/O Return: -12.5, +16.0 V
- Resolution: 16 Bit and fully monotonic
- Unadjusted offset: < 50 mV
- Offset drift typ: $250 \mu\text{V} / ^\circ\text{C}$
- Gain or slope tolerance: $\pm 3\%$
- Nonlinearity: < 0.1% of full scale or 12.5 mV
- Common Mode Rejection Ratio: > 30 dB at 60 Hz
- Input impedance: > 13k Ohms
- Signal to noise ratio referred to full scale:
 - AIN.CUTOFF = 3000 Hz: 14 bit
 - AIN.CUTOFF = 800 Hz: 16 bit

Analog Input Wiring Diagram

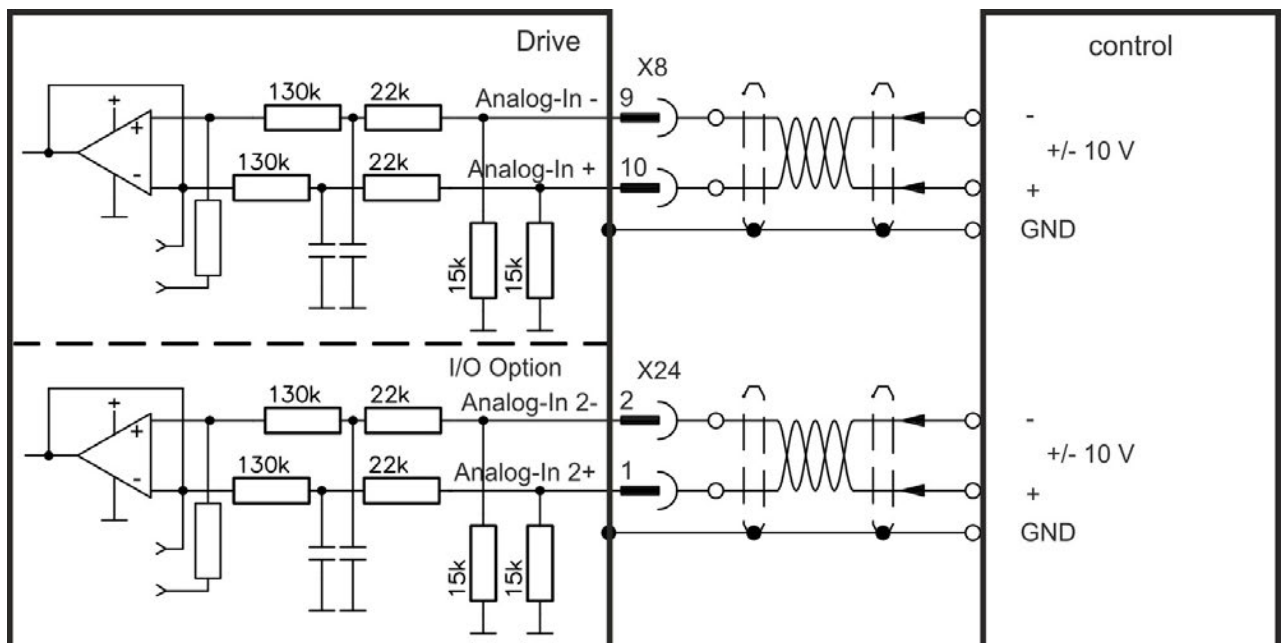

Application examples for set point input Analog-In:

- reduced-sensitivity input for setting-up/jog operation
- pre-control/override

Defining the direction of rotation

Standard setting: clockwise rotation of the motor shaft (looking at the shaft end) affected by positive voltage between terminal (+) and terminal (-)

To reverse the direction of rotation, swap the connections to terminals +/-, or change the DRV.DIR parameter in the "Feedback 1" screen page.

8.13.5 Analog Output (X8, X23)

Analog Outputs can be used to output converted analog values of digital measurements recorded in the drive. The standard drive offers one analog output on X8, drives with built-in I/O option card offer a second output on X23. A list of the pre-programmed functions is included in the WorkBench setup software.

Technical characteristics

- Output voltage range referring to AGND: $\pm 10\text{ V}$
- Resolution: 16 Bit and fully monotonic
- Unadjusted offset: $< 50\text{ mV}$
- Offset drift typ: $250\ \mu\text{V}/^\circ\text{C}$
- Gain or slope tolerance: $\pm 3\%$
- Nonlinearity: $< 0.1\%$ of full scale or 10 mV
- Output impedance: $110\ \text{ohms}$
- Specification complies with IEC 61131-2 Table 11
- -3 dB Bandwidth: $> 8\text{ kHz}$
- Maximum output current: 20 mA
- Capacitive load: any value but response speed limited by max Iout and by Rout
- Protected for short circuit to AGND

Analog Output Wiring Diagram

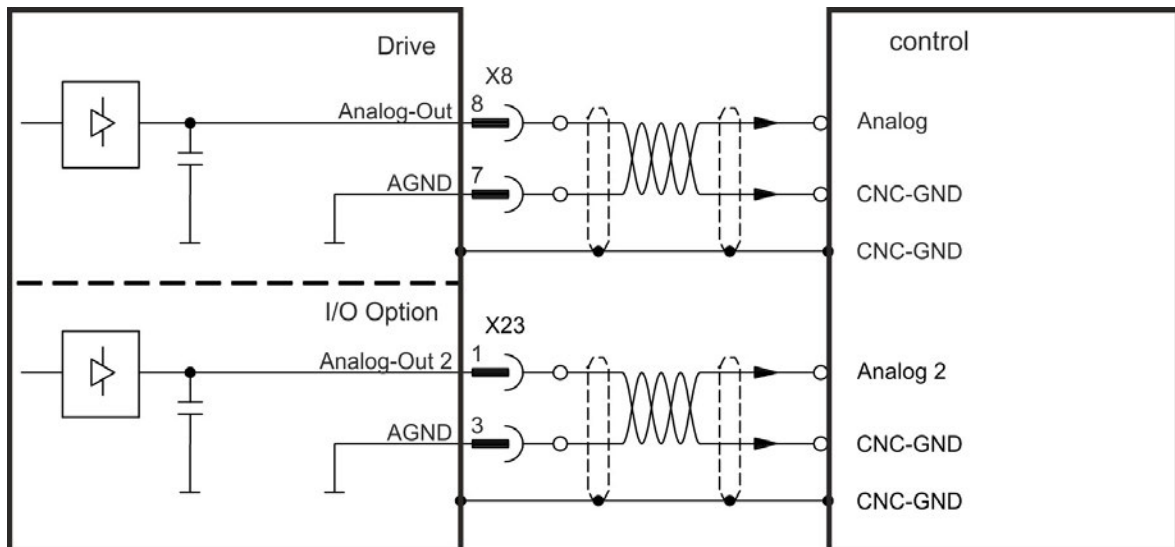

8.13.6 Digital Inputs (X7/X8)

The drive provides 8 digital inputs (→ p. 125). These can be used to initiate pre-programmed functions that are stored in the drive. A list of these pre-programmed functions is included in the WorkBench. Digital Input 8 is not programmable but is fixed to the ENABLE function. If an input is programmed, it must be saved to the drive.

NOTE

Depending on the selected function, the inputs are high or low active.

The inputs can be used with switched +24 V (source type) or switched GND (sink type). See diagrams below for typical examples of digital input wiring.

Digital Input Wiring Diagram (Source type connection, example)

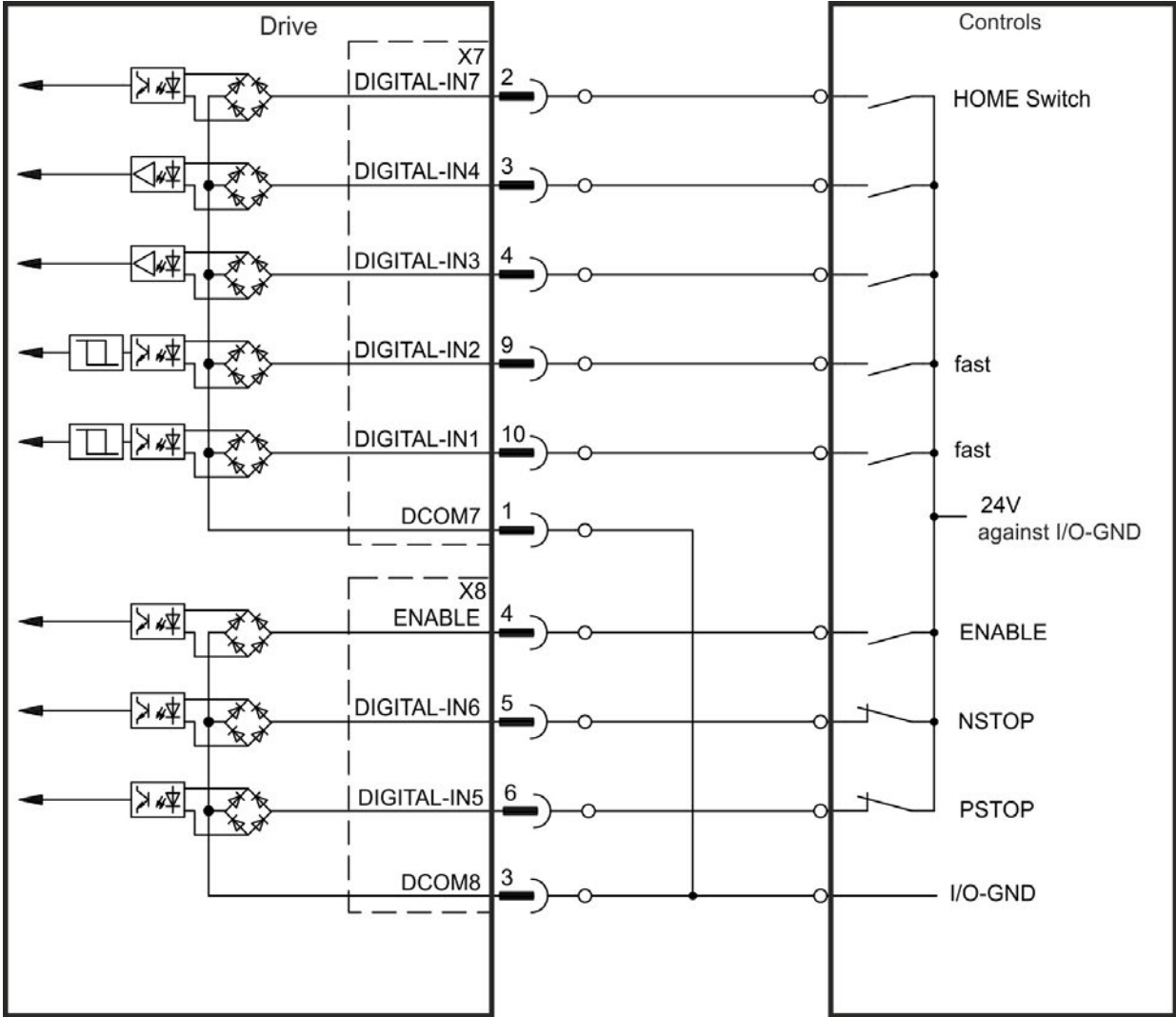

Digital Input Wiring Diagram (Sink type connection, example)

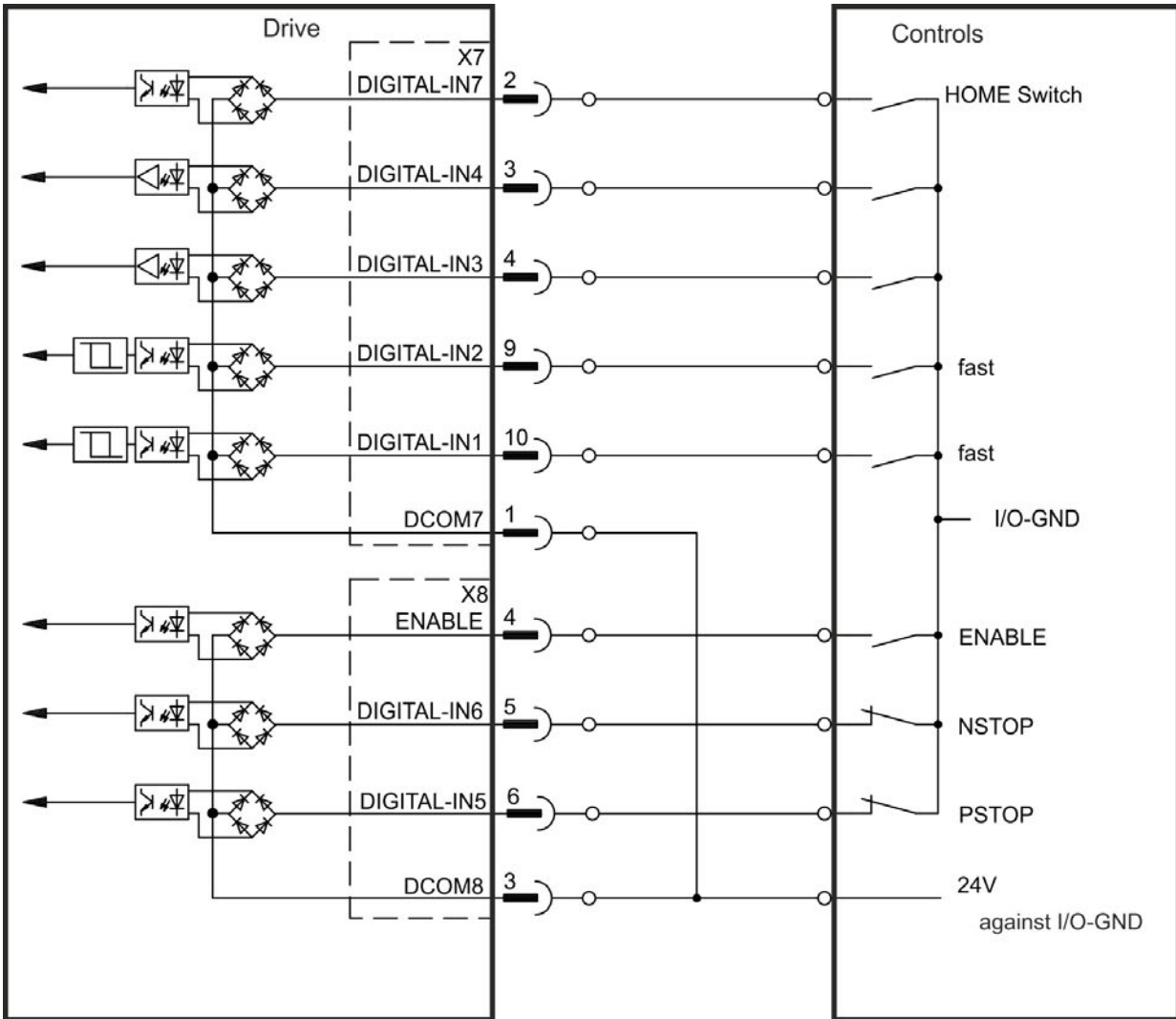

8.13.6.1 Digital Inputs 1 and 2

These inputs (X7/9 and X7/10) are particularly fast and are therefore suitable for latch functions, for example. They can also be used as 24 V inputs for electronic gearing (→ p. 117).

Technical characteristics

- Floating, reference common line is DCOM7
- Sink or Source type sensors possible
- High: 3.5 to 30 V/2 to 15 mA , Low: -2 to +2 V/<15 mA
- Update rate: Hardware 2 µs

8.13.6.2 Digital Inputs 3 to 7

These inputs are programmable with the setup software. By default, all inputs are not programmed (off).

For more information refer to the setup software.

Technical characteristics

Choose the function you require in WorkBench.

- Floating, reference common line is DCOM7 or DCOM8
- Sink or Source type sensors possible
- High: 3.5 to 30 V/2 to 15 mA , Low: -2 to +2 V/<15 mA
- Update rate: Software 250 µs

8.13.6.3 Digital Input 8 (ENABLE)

Digital Input 8 (terminal X8/4) is set to Enable function.

- Floating, reference common line is DCOM8
- Sink or Source type wiring is possible
- High: 3.5 to 30 V/2 to 15 mA , Low: -2 to +2 V/<15 mA
- Update rate: direct connection to hardware (FPGA)

NOTE

The Hardware Enable input and the Software Enable signal (via fieldbus or WorkBench) are serial, that means wiring of Hardware Enable is mandatory.

The output stage of the drive is enabled by applying the ENABLE signal (Terminal X8/4, active high). Enable is possible only if input STO has a 24 V signal (see "Safe Torque Off (STO)" on page 52). In the disabled state (low signal) the connected motor has no torque.

A software enable by means of the setup software is also required (AND link), although this can also be permanently enabled with WorkBench.

8.13.7 Digital Outputs (X7/X8)

8.13.7.1 Digital Outputs 1 and 2

The drive supplies 2 digital outputs (X7/5 to X7/8, → p. 125). Choose the required function in the setup software. Messages from pre-programmed functions stored in the drive can be output here. A list of these pre-programmed functions can be found in the setup software. If an output is to be assigned to a pre-programmed function, then the parameter set must be saved in the drive.

Technical characteristics

- 24 V IO power supply at terminals X7/8 and X7/6, 20 VDC to 30 VDC
- All digital outputs are floating,
DIGITAL OUT 1/2: terminals X7/7-8 and X7/5-6), max. 100 mA
- Can be wired as active low or active high (see examples below)
- Update rate: 250 μs

Wiring diagram

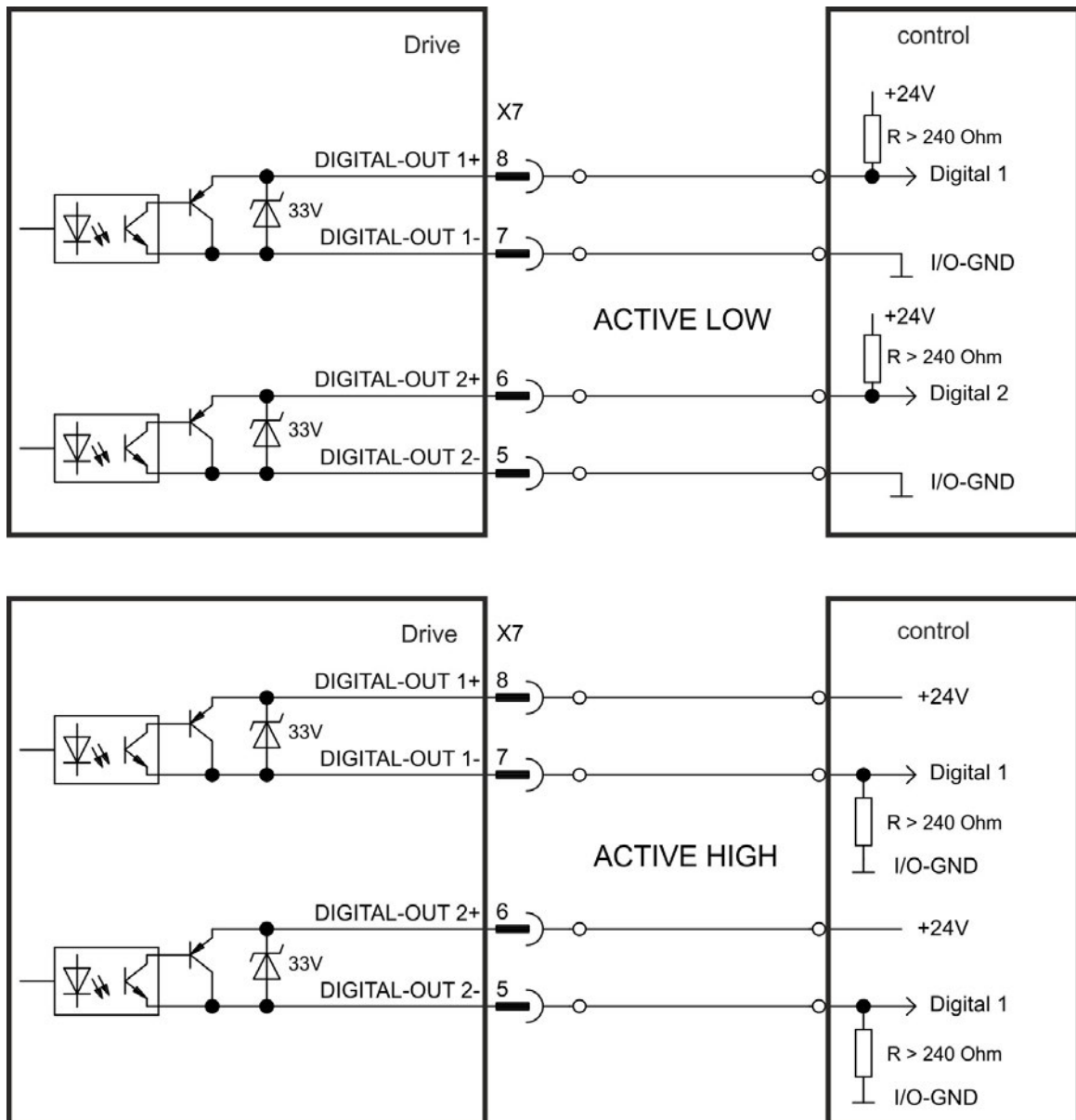

8.13.7.2 FAULT relay contacts

Operational readiness (terminals X8/1 and X8/2) is signaled by a floating relay contact.

The fault relay can be programmed to two modes of operation:

- Contact closed when there is no fault
- Contact closed when there is no fault and the drive is enabled.

The signal is not influenced by the enable signal, the I^2t -limit, or the regen threshold.

Technical characteristics

- FAULT: Relay output, max. 30 VDC or 42 VAC, 1 A
- Time to close: max. 10 ms
- Time to open: max. 10 ms

NOTE

All faults cause the FAULT contact to open and the output stage to be switched off (if the FAULT contact is open, the output stage is inhibited -> no power output). List of the fault messages: → p. 180.

Wiring diagram

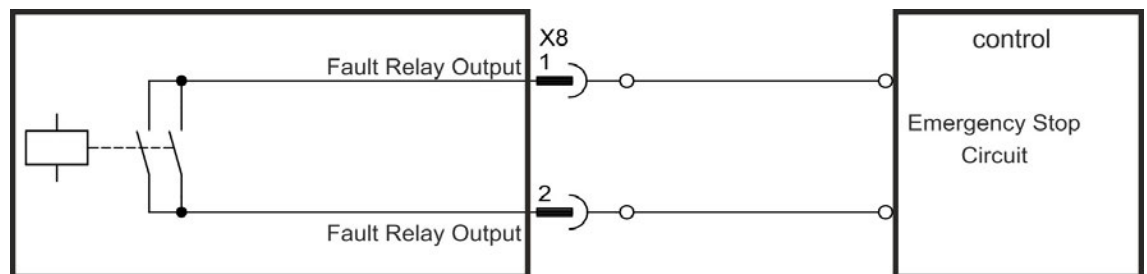

8.13.8 Digital Inputs with I/O option (X21, X22)

The drive option "IC" provides 12 additional digital inputs (→ p. 125). These can be used to initiate pre-programmed functions that are stored in the drive. A list of these pre-programmed functions is included in WorkBench. If an input is programmed, it must be saved to the drive.

NOTE

Depending on the selected function the inputs are high or low active.

The inputs can be used with switched +24 V (source type) or switched GND (sink type).

Technical characteristics

- Floating, sink or source type sensors possible
- High: 3.5 to 30 V/2 to 15 mA , Low: -2 to +2 V/<15 mA, Update rate: Software 250 µs

Digital Input Wiring Diagram (Source type connection, example)

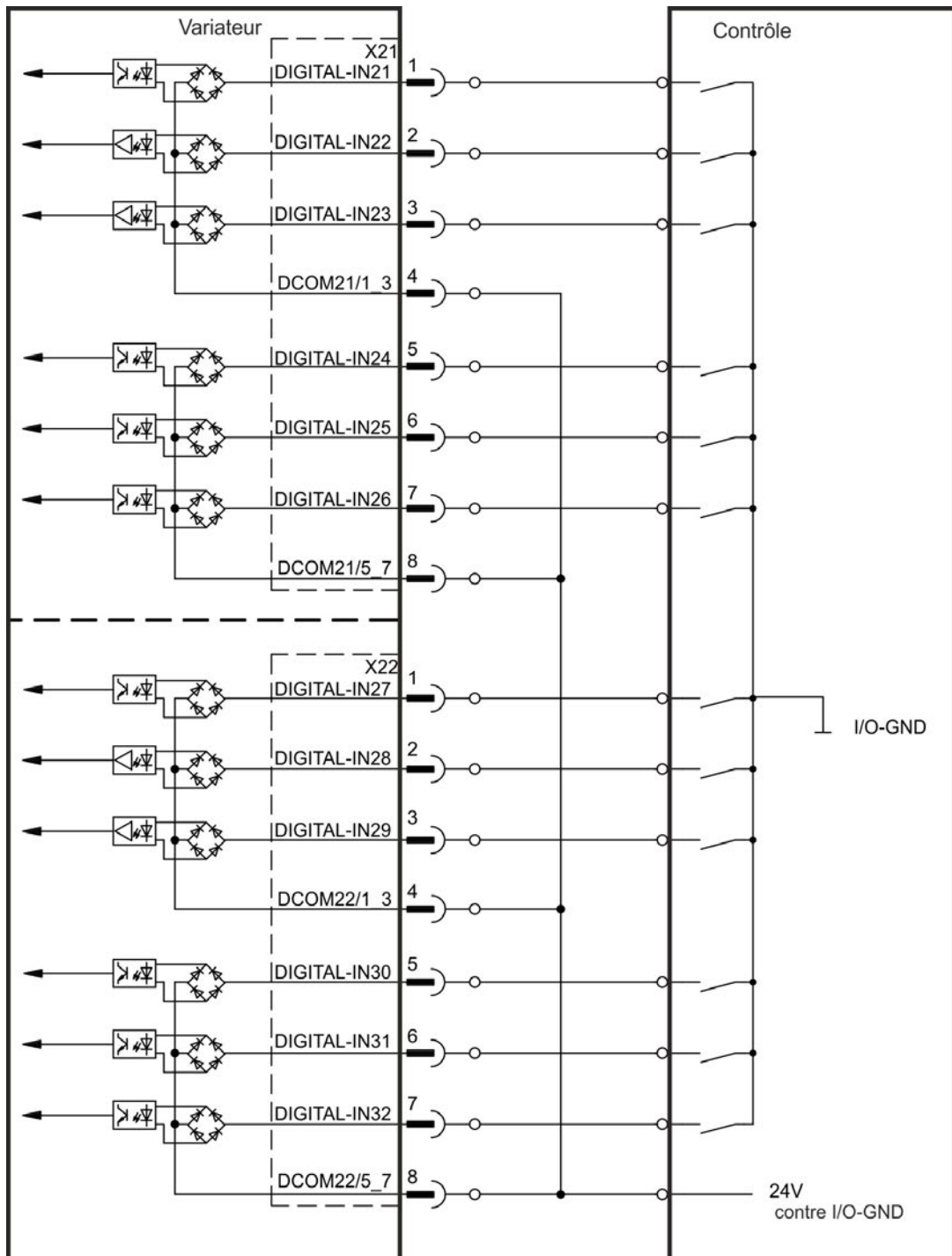

Digital Input Wiring Diagram (Sink type connection, example)

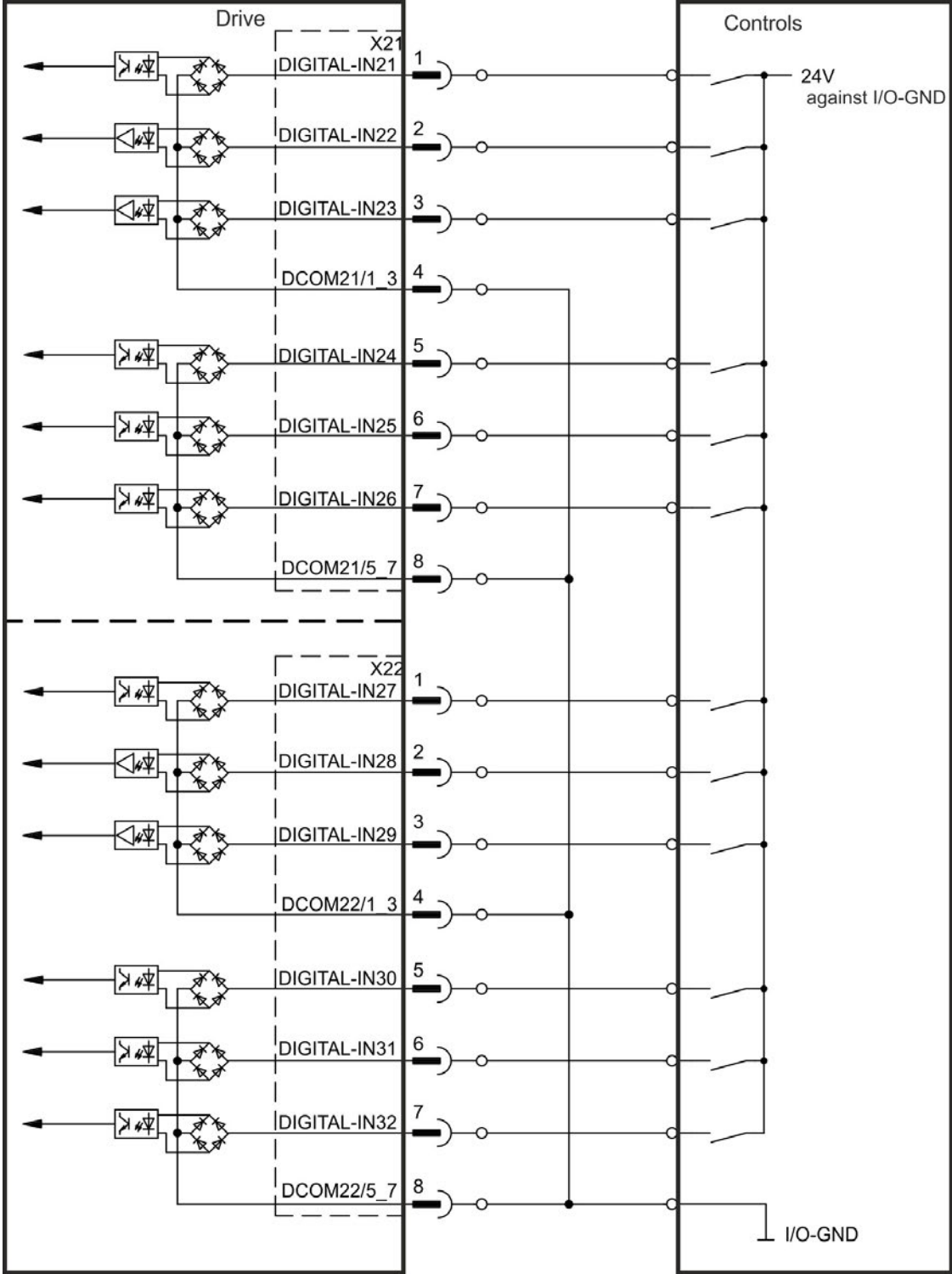

8.13.9 Digital Outputs with I/O option (X23/X24)

8.13.9.1 Digital Outputs 21 to 24, 26 to 29

The drive option "IC" provides 10 digital outputs (→ p. 125). Choose the required function in the setup software. Messages from pre-programmed functions stored in the drive can be output here. A list of these pre-programmed functions can be found in the setup software. If an output is to be assigned to a pre-programmed function, then the parameter set must be saved in the drive.

Technical characteristics

- 24 V IO power supply, 20 VDC to 30 VDC, floating, max. 100 mA
- Can be wired as active low or active high (see examples below)
- Update rate: 250 µs

Wiring diagram

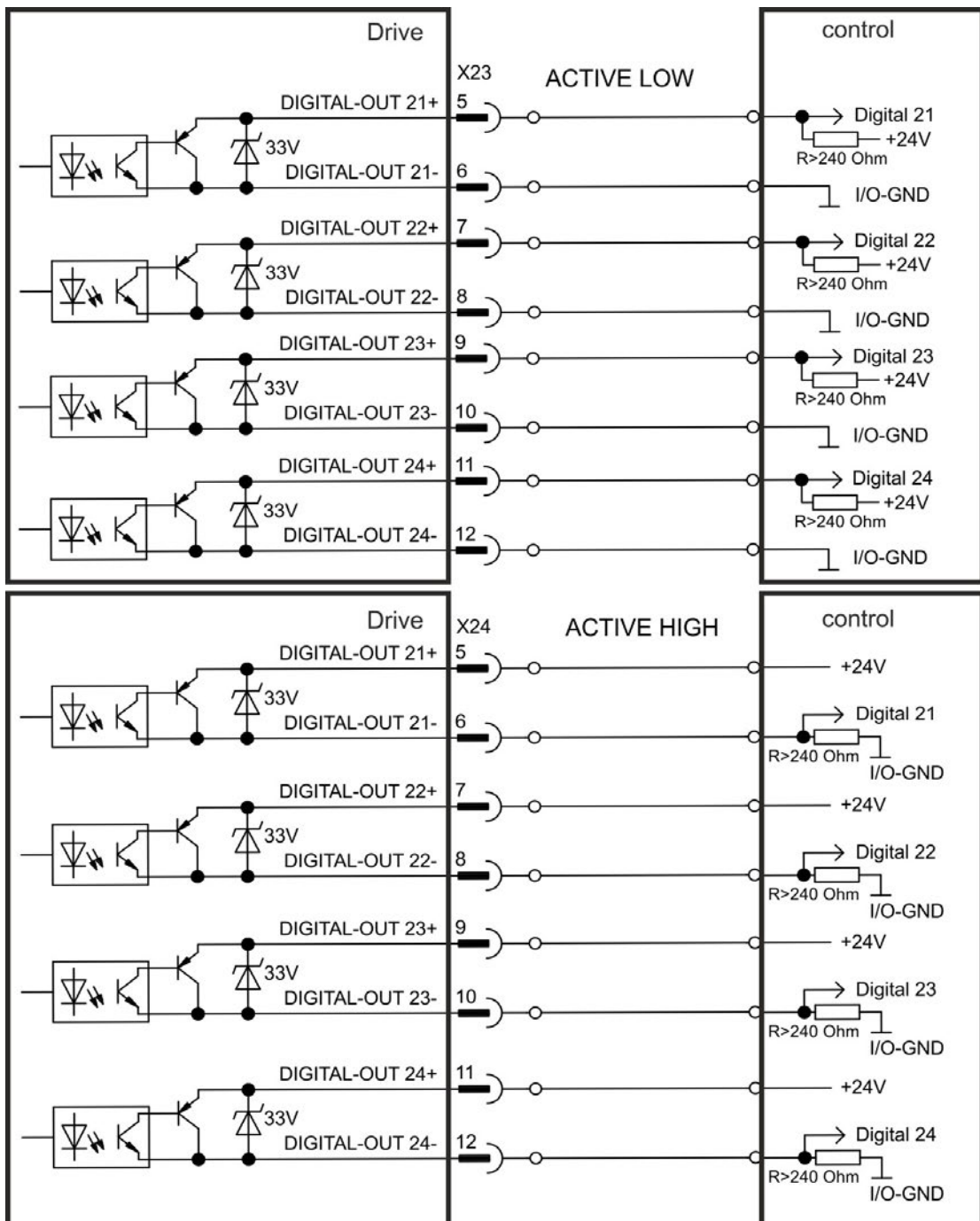

8.13.9.2 Digital Relay Outputs 25, 30

The drive option "IC" provides two digital outputs, which are signaled by floating relay contacts (→ p. 125). Choose the required function in the setup software. Messages from pre-programmed functions stored in the drive can be output here. A list of these pre-programmed functions can be found in the setup software. If an output is to be assigned to a pre-programmed function, then the parameter set must be saved in the drive.

Technical characteristics

- Relay output, max. 30 VDC or 42 VAC, 1 A
- Time to close: max. 10 ms
- Time to open: max. 10 ms

Wiring diagram

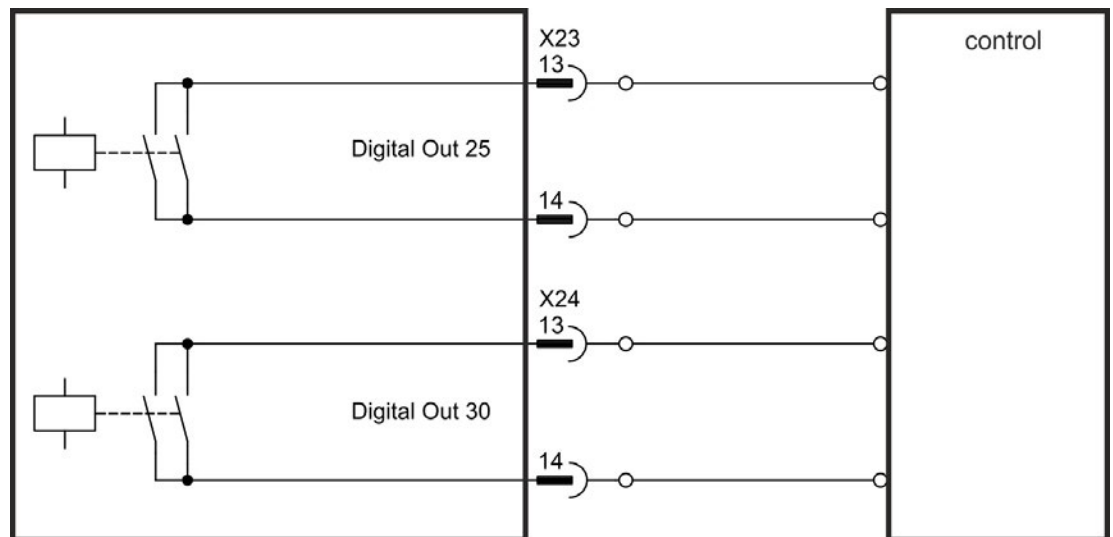

8.13.10 Digital Inputs (X35/X36) with AKD-M

In addition to the 8 digital inputs on X7 and X8 (→ p. 125), the AKD PDMM provides 6 digital inputs on X35 and X36. These can be used to initiate pre-programmed functions that are stored in the drive. A list of these pre-programmed functions is included in the KAS IDE. If an input is programmed, it must be saved to the drive. By default, all inputs are not programmed (off). For more information refer to the setup software.

NOTE Depending on the selected function the inputs are high or low active.

Technical characteristics

Choose the function you require in KAS IDE.

- Floating, reference common line is DCOM35 or DCOM36
- Sink or Source type sensors possible
- High: 3.5 to 30 V/2 to 15 mA , Low: -2 to +2 V/<15 mA
- Update rate: Software 250 µs

The inputs can be used with switched +24 V (source type) or switched GND (sink type). See diagrams below for typical examples of digital input wiring.

Digital Input Wiring Diagram (Source type connection, example)

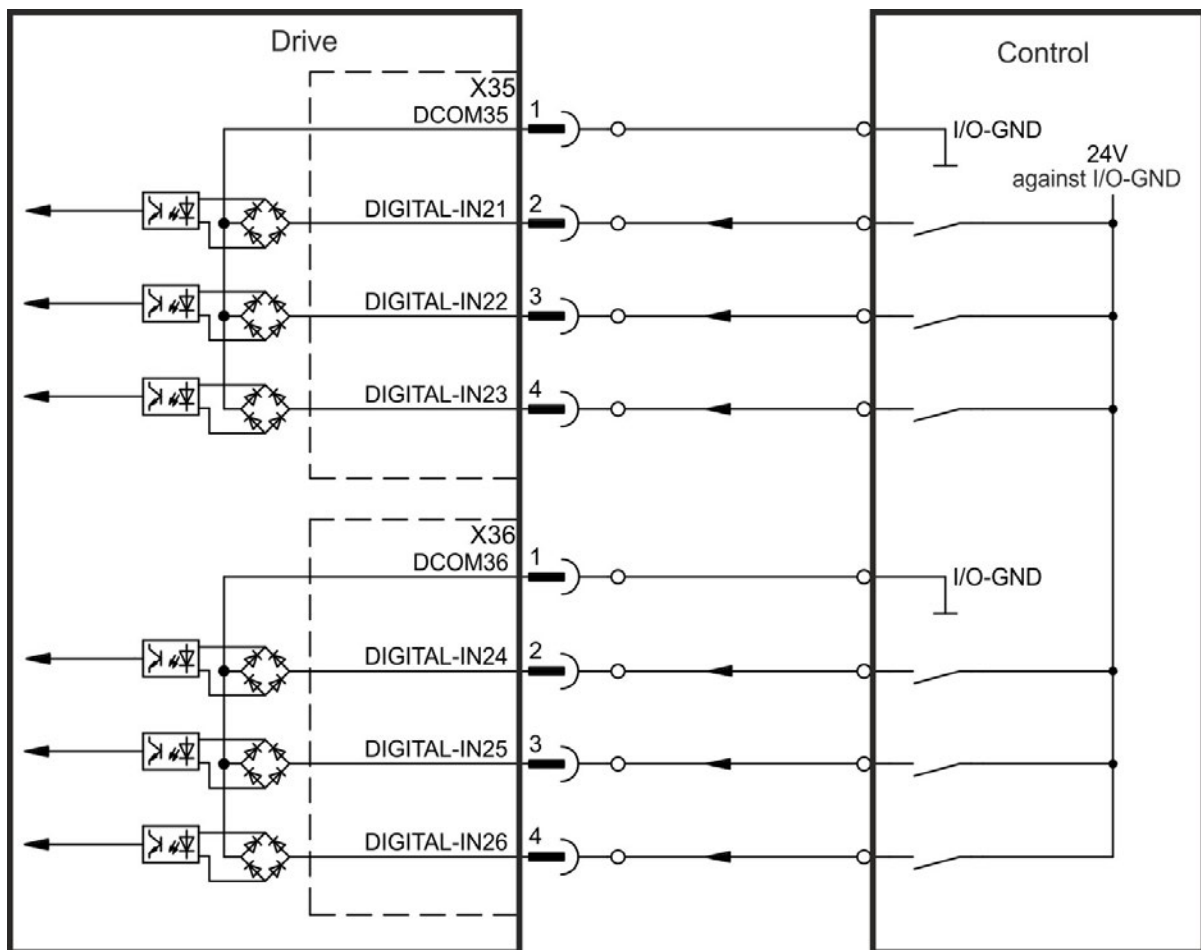

Digital Input Wiring Diagram (Sink type connection, example)

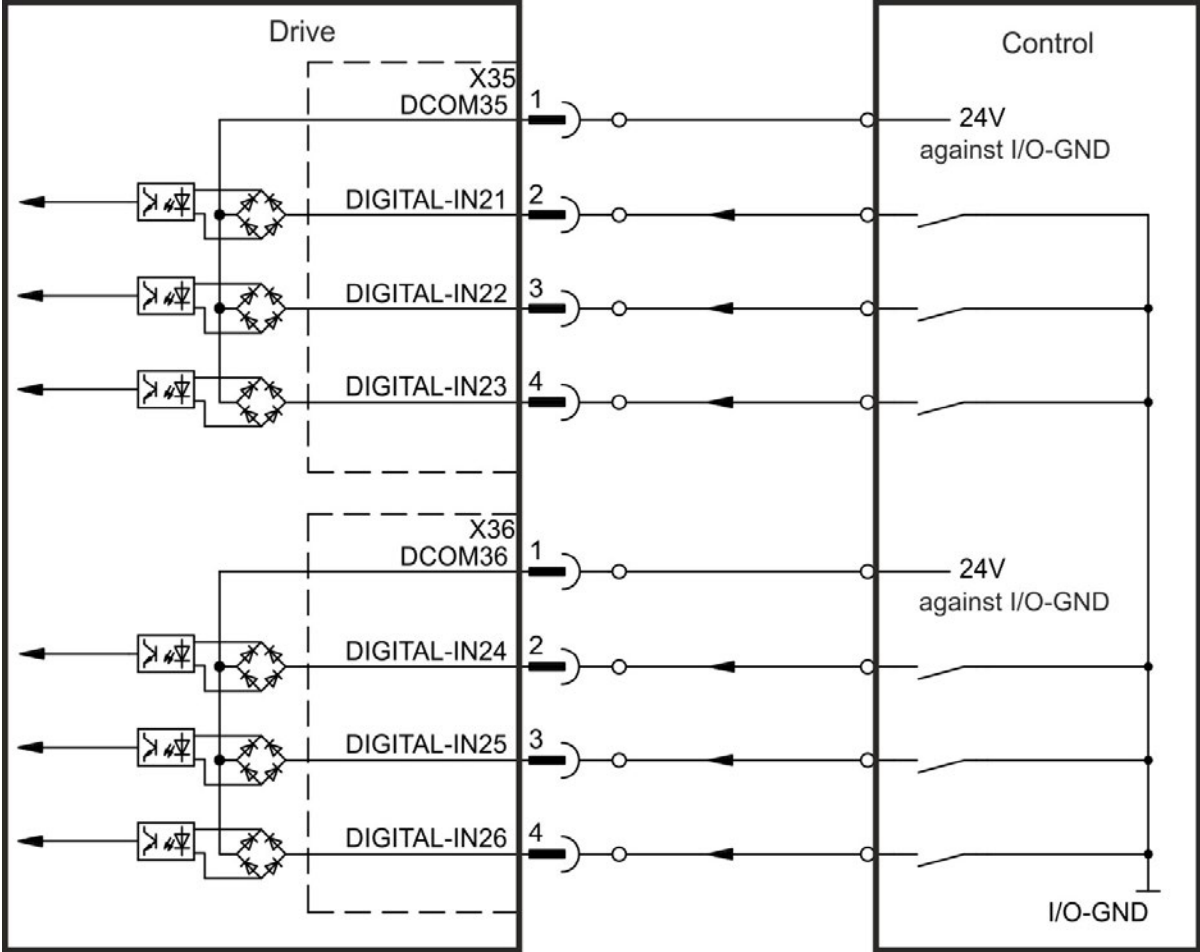

8.13.11 Digital Outputs (X35/X36) with AKD-M

8.13.11.1 Digital Outputs 21 and 22

In addition to the 2 digital outputs on X7 (→ p. 125), the AKD PDMM provides 2 digital outputs on X35 and X36. Choose the required function in the setup software. Messages from pre-programmed functions stored in the drive can be output here. A list of these pre-programmed functions can be found in the setup software. If an output is to be assigned to a pre-programmed function, then the parameter set must be saved in the drive.

Technical characteristics

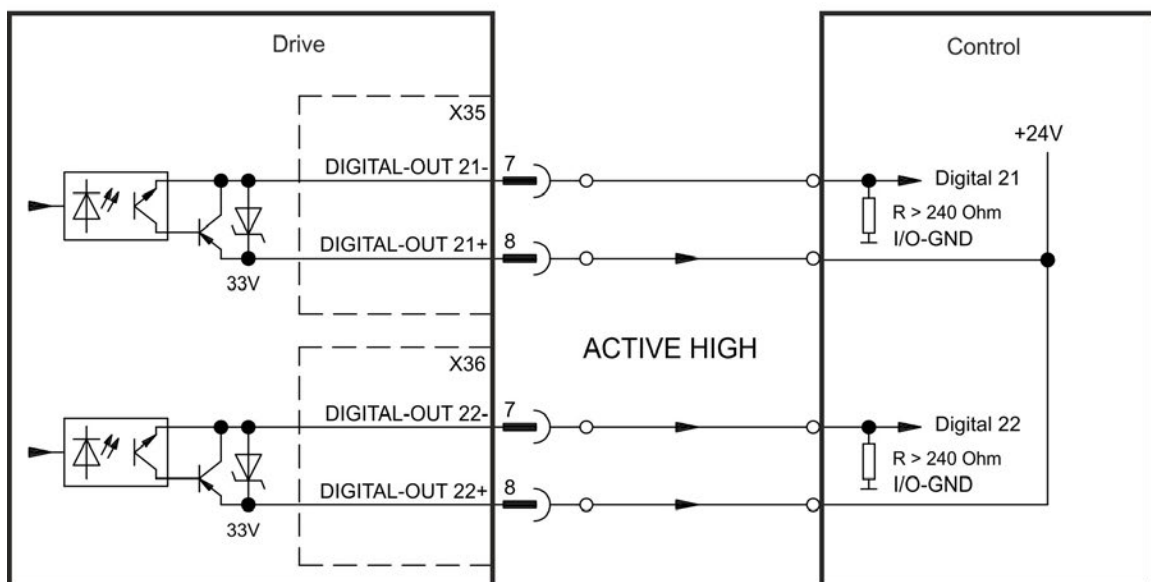
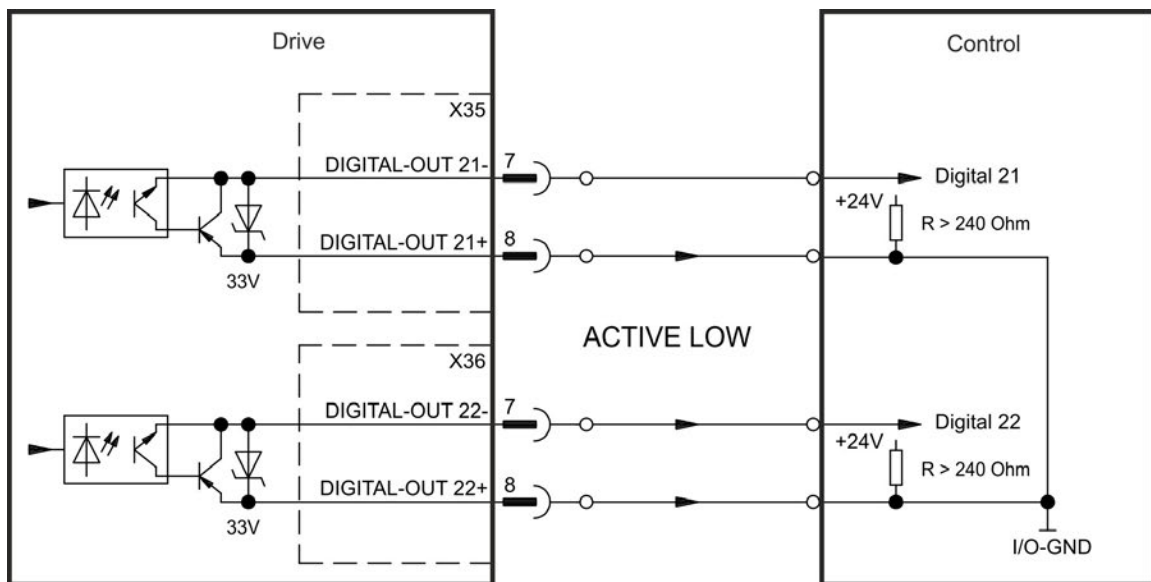

- 24 V IO power supply at terminals X35/8 and X36/8, 20 VDC to 30 VDC
- All digital outputs are floating, max. 100 mA
- Can be wired as active low or active high (see examples below)
- Update rate: 250 µs

Wiring diagram



8.14 LED display

The LED seven-segment display indicates the status of the drive after the 24 V supply is switched on. If the service connection to the PC or to the PAC doesn't work, then the LED display is the only way to get information.

AKD two digits	AKD-M two + one digits
	
<p>AKD fault codes or warning codes are displayed constantly if present. Fault messages are coded with "F" or "E", warnings are coded with "n". The IP address can be flashed across the LED display if the B1 button is pressed.</p>	<p>The two digits LED display indicates the AKD messages. Fault messages are coded with "F", warnings are coded with "n".</p> <p>The one digit LED indicates the PDMM messages of the AKD PDMM. Error messages are coded with "E", warnings (alarms) are coded with "A". Status of application programs are indicated as well. With push-buttons B2 and B3 a menu with several functions can be started (→ p. 146).</p>

SeeWorkBench Onlinehelp for details.

8.15 Rotary Switches (S1, S2, RS1)

Rotary switches can be used to select IP address or predefined functions for executing.

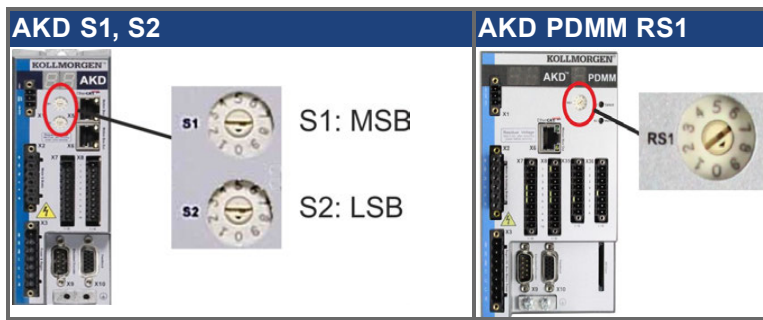

8.15.1 Rotary switches S1 and S2 with AKD-B, -P, -T

S1	S2	Function	Set while	Remarks
0	0	DHCP IP	24 V is OFF	The drive acquires its IP address from an external DHCP server, details see → p. 150.
x	y	Static IP	24 V is OFF	The IP address is 192.168.0.nn, valid values are 01 to 99, details see → p. 150.
AKD-x****-CC only				
8	9	DRV.TYPE toggle	24 V is ON and drive is disabled	Press B1 for 3s to switch over from CAN to EtherCAT fieldbus or vice versa (→ p. 154 and → p. 159). Switch 24V off and on again.
AKD with I/O option card only				
1	0	Load data	24 V is ON and AKD is disabled	Press B1 for 5s for loading data from the SD card to the drive, details see → p. 147.
1	1	Save data	24 V is ON and AKD is disabled	Press B1 for 5s for save data from the drive to the SD card, details see → p. 147.
AKD-T only				
1	2	Stop program	24 V is ON	Press B1 for 5s for stopping the BASIC program
1	3	Restart program	24 V is ON	Press B1 for 5s for restarting the BASIC program

8.15.2 Rotary switch RS1 with AKD-M

RS1	Function	Set while	Remarks
0	DHCP IP	24 V is OFF	The drive will acquire its IP address from an external DHCP server (→ p. 152).
1	Static IP	24 V is OFF	The IP address is software configurable from a web-browser (→ p. 152).
2 to 9	Static IP	24 V is OFF	The IP address is 192.168.0.10n, valid values are 2 to 9 (→ p. 152).

8.16 Pushbuttons (B1, B2, B3)

The pushbuttons can be used to start predefined functions.

8.16.1 Pushbutton B1 with AKD-B, -P, -T

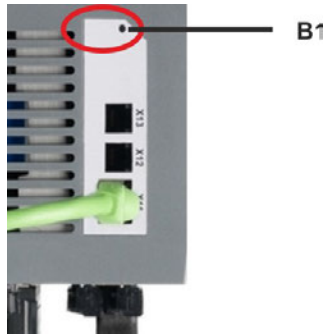

Function	Pushbutton	Remarks
Display IP address	B1	Press short to display the IP address in the two digit display
Switches Drive Type of AKD-x***CC model	B1	Set rotary switches S1 to 8 and S2 to 9. Press B1 for 3 sec to switch over from CAN to EtherCAT or reverse.
Load data from SD card	B1	Drives with I/O option card only. Set rotary switches S1 to 1 and S2 to 0. Press B1 for 5s for loading data from the SD card to the drive.
Save data to SD card	B1	Drives with I/O option card only. Set rotary switches S1 to 1 and S2 to 1. Press B1 for 5s for save data from the drive to the SD card.

8.16.2 Pushbuttons B1, B2, B3 with AKD-M

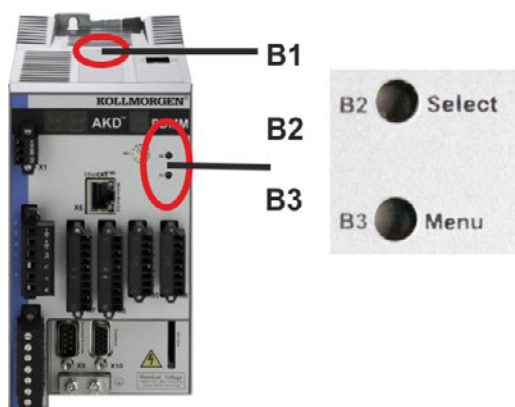

Function	Pushbutton	Remarks
-	B1	Unused
Boot-time functions (press and hold button during power-on boot sequence)		
Recovery Mode	B2	Press and hold to boot into recovery mode.
Menu	B3	Press and hold to block the application auto-start and to start cycling through the menu items.
Operational functions (press button during normal operation mode)		
Menu	B3	Press to cycle through the menu items. The menu items will be displayed on the 7-segment LED repeatedly for 10 s and can be selected by pressing B2.
Select Menu Item	B2	Press while the required menu item is displayed to perform action. Application is running , available menu items: <ul style="list-style-type: none"> • 'IP' address • 'stop' application (confirm) No application is running , available menu items: <ul style="list-style-type: none"> • 'IP' address • 'start' application (confirm) • 'reset' to defaults (confirm) • 'backup' to SD card (confirm) (→ p. 148) • 'restore' from SD card (confirm) (→ p. 148)
Confirm	B2	If the selected menu item selection requires a confirmation, "y" is displayed for 10 s - press B2 to confirm.

8.17 SD Card Slot

8.17.1 SD Card Slot with I/O option card

Drives with I/O option card offer a SD card slot to activate file transfers from/to the AKD and SD Memory Card. These features can be started from the WorkBench software or with push-button B1 (top of the drive) combined with rotary switch setting 10 or 11. Detailed description can be found in the AKD *User's Guide*.

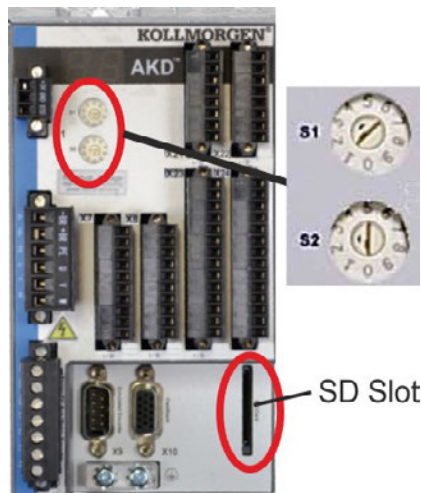

NOTE

The save/load operations (AKD to SD or SD to AKD) are only possible while no program is running and the drive is disabled.

BASIC programs and non volatile parameters can be saved/loaded.

If a fault occurs during save/load operations, the fault number is displayed in the display with E followed by four digits. Error codes → p. 180 .

Supported SD card types

SD cards are preformatted by the manufacturer. The following table outlines the SD card types and AKD support.

SD Type	File System	Capacity	Supported
SD (SDSC)	FAT16	1MB to 2GB	YES
SDHC	FAT32	4GB to 32GB	YES
SDXC	exFAT (Microsoft)	>32GB to 2TB	NO

Features

If an SD card is plugged into the SD slot and the drive is disabled and no programm is running, set rotary switches as described below and press B1 for 5s to start the set function:

Function	S1	S2	Remarks
Save data to SD card	1	1	Press B1 for 5s for save data from the drive to the SD card.
Load data from SD card	1	0	Press B1 for 5s for loading data from the SD card to the drive.

8.17.2 SD Card Slot with AKD-M

AKD PDMM offers a SD card slot and pushbuttons B2 and B3 to activate file transfers from/to the AKD PDMM and SD Memory Card. These features can be started from the KAS IDE software as well. Detailed description can be found in the *AKD PDMM User's Guide*.

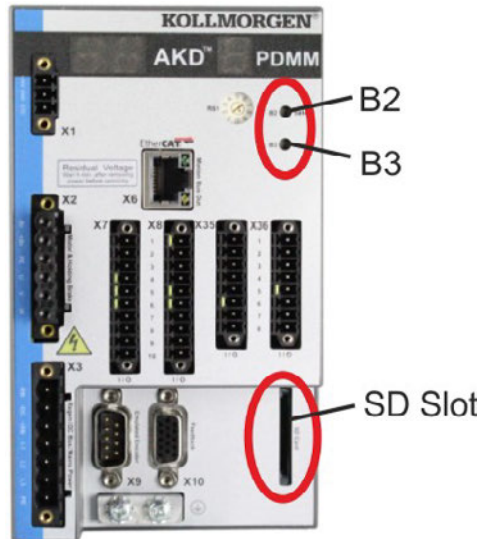

The backup/restore operations (AKD PDMM to SD or SD to AKD PDMM) will not be possible if an application is running.

NOTE

Stop the application from the web-browser or use the B2/B3 “stop” action before initiating any SD card functionality.

If a fault occurs during save/load operations, the fault number is displayed in the one digit display with E followed by two digits. Error codes → p. 190 .

Supported SD card types

SD cards are preformatted by the manufacturer. The following table outlines the SD card types and AKD PDMM support.

SD Type	File System	Capacity	Supported
SD (SDSC)	FAT16	1MB to 2GB	YES
SDHC	FAT32	4GB to 32GB	YES
SDXC	exFAT (Microsoft)	>32GB to 2TB	NO

Features

If an SD card is plugged into the SD slot and no application program is running, the push-button menu (started with B3, → p. 145) shows the possible data transfer functions:

- 'backup' to copy firmware, configurations, user application, and user data files from the AKD PDMM to SD card.
- 'restore' to load firmware, configuration, user application, and user data files from SD card to AKD PDMM.

8.18 Service Interface (X11, X32)

Operating, position control, and motion-block parameters can be set up by using the setup software on an ordinary commercial PC ("Hardware requirements" (→ p. 165)).

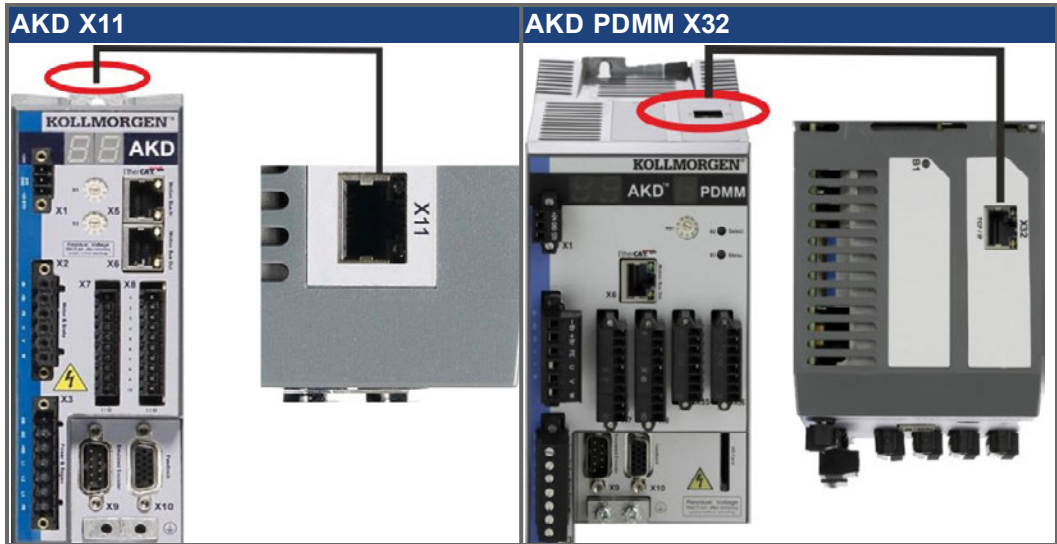

Connect the service interface (X11 or X32) of the drive to an Ethernet interface on the PC directly or via a network hub/switch, **while the supply to the equipment is switched off**. Use standard Cat. 5 Ethernet cables for connection (in some cases crossover cables will also work).

Confirm that the link LED on the AKD (the green LED on the RJ45 connector) and on your PC (or network Hub/Switch) are both illuminated. If both lights are illuminated, then you have a good electrical connection.

8.18.1 Pinout X11, X32

Pin	Signal	Pin	Signal
1	Transmit +	5	n.c.
2	Transmit -	6	Receive-
3	Receive+	7	n.c.
4	n.c.	8	n.c.

8.18.2 Service Bus Protocols X11, X32

Protocol	Type	Connector
Modbus TCP	Service Bus	X11, X32
Ethernet TCP/IP	Service Bus	X11, X32

8.18.3 Possible Network Configurations

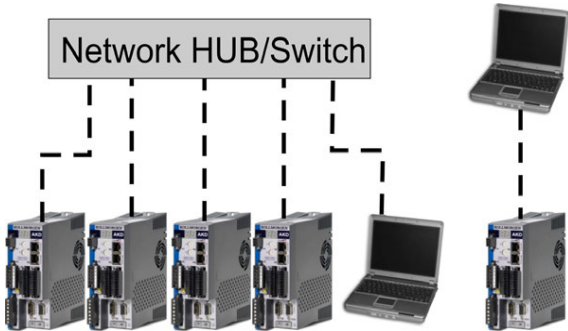

8.18.4 Setting the IP Address AKD-B, AKD-P, AKD-T

The IP address can be flashed across the LED display if the B1 button is pressed.



You can use the rotary switches to set the IP address of the AKD. For CANopen and some other fieldbuses, the rotary switches also set the node address of the drive for that specific network.

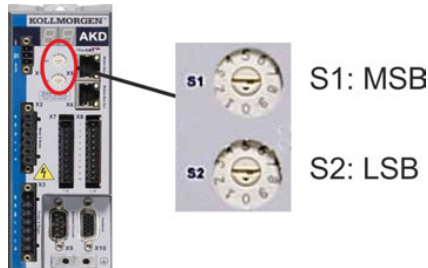

Rotary Switch Setting	Drive IP Address
00	DHCP/AutoIP address. The IP address of the drive is obtained from the DHCP server on your network. If no DHCP server is found the IP addresses is an AutoIP address (it is internally generated following the AutoIP protocol and will be of the form 169.254.xx.xx).
01 to 99	Static IP Address. The IP address is 192.168.0.nn, where nn is the number from the rotary switch. This setting generates addresses in a range from 192.168.0.1 to 192.168.0.99. Example: if S1 is set to 2 and S2 is set to 5 – the IP address is 192.168.0.25

NOTE

The PC subnet mask must be set to 255.255.255.0 or 255.255.255.128
When connecting the AKD directly to a PC, use static IP addressing (not 00).

Static IP addressing

When connecting the drive directly to a PC, static IP addressing must be used. Set rotary switches S1 and S2 to a number different from 00.
This setting generates addresses in a range from 192.168.0.001 to 192.168.0.099.

Dynamic IP addressing (DHCP and Auto-IP)

With S1 and S2 both set to 0, the drive is in DHCP mode. The drive will acquire its IP address from an external DHCP server if present in the network. If a DHCP server is not present, the drive will assume an Automatic Private IP Address of the form 169.254.x.x.
If your PC is directly connected to the drive, and set to obtain an IP address automatically in the TCP/IP settings, a connection will be established with both devices using compatible automatically generated addresses. It can take up to 60 seconds for a PC to configure an Automatic Private IP Address (169.254.x.x).

Changing the IP address

If the switches are altered while 24 V Logic power is supplied to the drive, you must switch off and then switch on again the 24 V supply voltage. This action will reset the address.

IP address mode

By default, the drive utilizes the method described above to acquire its IP address. A method of setting the IP address independent of the Rotary switches is available. More information is available in the AKD User Guide or in the Settings Screen-> Fieldbus-> TCP/IP screen in WorkBench.

Recovering Communications with a Drive on an Un-Reachable IP Address

If IP.MODE has been set to 1 (using software defined static IP), the drive will boot up on an IP Address that may be unreachable with the host computer's settings.

If the IP address prevents communication, the IP settings can be reset to default by the following procedure:

- Set both rotary switches to 0
- Hold down button B1 (top-side of drive) for 5 seconds.

The display will flash 0.0.0.0 and then attempt to discover an address by DHCP.

Without removing logic power from the drive, use WorkBench to connect to the drive, reconfigure the IP address settings as desired, and store the values to non-volatile memory.

8.18.5 Setting the IP Address AKD-M

You can use the rotary switch RS1 to set the IP address of the AKD PDMM. The configured IP address (depending on the current rotary switch RS1 position) will be displayed on the 7 segment at Ethernet cable connection time and at power-on, if an Ethernet cable is connected.. If no Ethernet cable is connected, no IP address will be indicated in the display.

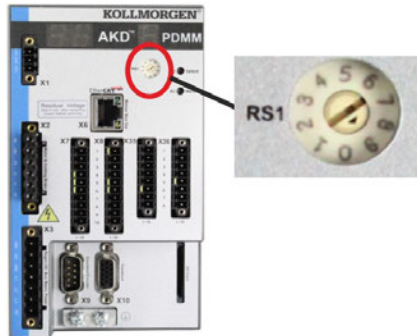

Rotary Switch Setting	Drive IP Address
0	DHCP/AutoIP address. The IP address of the drive is obtained from the DHCP server on your network. If no DHCP server is found the IP addresses is an AutoIP address (it is internally generated following the AutoIP protocol and will be of the form 169.254.xx.xx).
1	Static IP Address. The IP address is software configurable from a web-browser. The default IP address at switch position 1 is 192.168.1.101. To configure the IP address, open a web browser and type the IP address in the URL box. The AKD PDMM web page will appear. Navigate to the Settings tab and then the Network tab to configure the static IP address for the AKD PDMM.
2 to 9	Static IP Address. The IP address is 192.168.0.10n, where n is the number from the rotary switch. This setting generates addresses in a range from 192.168.0.102 to 192.168.0.109. Example:if RS1 is set to 5 – the IP address is 192.168.0.105

NOTE

The PC subnet mask must be set to 255.255.255.0 or 255.255.255.128

Static IP addressing

When connecting the drive directly to a PC, static IP addressing must be used. Set rotary switch RS1 to a number from 2 to 9. This setting generates addresses in a range from 192.168.0.102 to 192.168.0.109.

Example: if RS1 is set to 5 – the IP address is 192.168.0.105

Dynamic IP addressing (DHCP and Auto-IP)

With RS1 set to 0, the drive is in DHCP mode. The drive will acquire its IP address from an external DHCP server if present in the network. If a DHCP server is not present, the drive will assume an Automatic Private IP Address of the form 169.254.x.x.

If your PC or PAC is directly connected to the drive, and set to obtain an IP address automatically in the TCP/IP settings, a connection will be established with both devices using compatible automatic generated addresses. It can take up to 60 seconds for a PC to configure an Automatic Private IP Address (169.254.x.x).

Changing the IP address

If the switch is altered while 24 V Logic power is supplied to the drive, you must switch off and then switch on again the 24 V supply voltage. This action will reset the address.

8.18.6 Modbus TCP

The drive can be connected to Modbus HMI via RJ-45 connector X11 (AKD) or X32 (AKD PDMM, for Kollmorgen touchpanels only). The protocol allows reading and writing of drive parameters.

The communication status is indicated by the built-in LEDs.

Connector	LED#	Name	Function
X11, X32	LED1	IN port Link	ON = active, OFF= not active
	LED2	RUN	ON = running, OFF = not running

Connect the service interface (X11, X32) of the drive to an Ethernet interface on the Modbus HMI directly or via a network switch, **while the supply to the equipment is switched off**. Use standard Cat. 5 Ethernet cables for connection.

The following are required to connect an HMI to the drive:

- The HMI must support Modbus TCP.
- It must have Ethernet hardware and a driver for Modbus TCP, though the driver does not have to be made specifically for the AKD family.

The Kollmorgen AKI HMI's are compatible with a "Kollmorgen Modbus Master" driver.

The subnet mask of the AKD is 255.255.255.0. The first three octets of the drive's IP address must be the same as the first three octets of the HMI's IP address. The last octet must be different.

Confirm that the link LED on the AKD (the green LED on the RJ45 connector) and on your Master or Switch are both illuminated. If both lights are illuminated, then you have a good electrical connection.

Modbus TCP and WorkBench/KAS IDE can operate simultaneously if a switch is used.

8.19 CAN-Bus Interface (X12/X13)

Two 6-pin RJ-25 connectors X12/X13 are used for CAN-Bus connection.



Conn.	Pin	Signal	Conn.	Pin	Signal
X12	1	Internal Termination Resistor	X13	1	Internal Termination Resistor
X12	2	CAN Shield	X13	2	CAN Shield
X12	3	CANH in	X13	3	CANH out
X12	4	CANL in	X13	4	CANL out
X12	5	GND	X13	5	GND
X12	6	Internal Termination Resistor	X13	6	Internal Termination Resistor

8.19.1 CAN-Bus activation with AKD-CC models

AKD-CC drive models are Drives, which support EtherCAT and CAN fieldbus types within one common software. These CC drive models allow selecting a fieldbus support by setting the DRV.TYPE parameter to a certain value. CC drive models are delivered with EtherCAT set active.

To activate CANopen, the DRV.TYPE parameter must be changed

1. by software: connect the PC to the AKD and change the parameter DRV.TYPE in the WorkBench terminal screen (see DRV.TYPE parameter documentation) or
2. by hardware: with the rotary switches S1 & S2 at the front and the button B1 on the top side of the Drive.

The following steps are needed for changing the fieldbus type from EtherCAT to CAN with the rotary switches.

1. Set the rotary switches on the front side of the AKD to the value of 89.

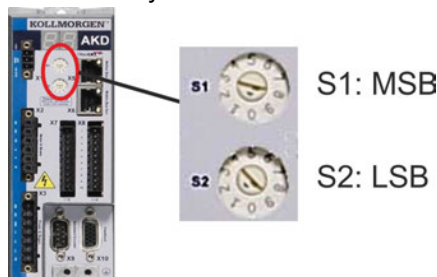

Set S1 to 8 and S2 to 9

2. Press the button B1 for about 3 seconds (starts DRV.NVSAVE).
Press B1 for 3 seconds.



The seven segment display shows **Cn** during the process of changing DRV.TYPE to CAN.

Do not switch off the 24[V] power supply while the seven segment shows Cn!

3. Wait until the seven segment display goes back to the original state, no the drive is prepared for CAN.
4. Power cycle the drive by switching the 24 V power supply **off** and then **on** again.

NOTE

The seven segment display shows Er (Error) in case that the DRV.TYPE instruction failed. In this case please power cycle the drive and contact the Kollmorgen customer support for further help.

8.19.2 Baudrate for CAN-Bus

The user can decide to use a fixed baud rate or an auto baud detection algorithm for the startup behaviour of the drive. The transmission rate can be set via the parameter **FBUS.PARAM01**. The parameter FBUS.PARAM01 can either be set via WorkBench or via a special mechanism with the rotary switches in the AKD front.

Baudrate [kBit/s]	FBUS.PARAM01	Upper rotary switch S1	Lower rotary switch S2
auto	0	9	0
125	125	9	1
250	250	9	2
500	500	9	3
1000	1000	9	4

In case of a fix baud rate, the drive sends the boot up message with the baud rate saved in the drive's non volatile memory after a power cycle. In case of auto baud detection, the drive listens for a valid CAN frame on the bus. When a valid frame is received, the drive sends the boot up message with the measured bit time. Afterwards the baud rate can either be stored to non volatile memory via object 1010 sub 1, or the auto baud mechanism is used always.

NOTE

For reliable auto baud detection, it is recommended to use suitable cabling of the CAN-Bus (two terminators, GND connection etc.). Spikes or other noise effects on the CAN-Bus can disturb the measurement. The drive needs to be disabled, if auto baud is in use.

For setting the baudrate with rotary switches, follow the procedure below (drive state disabled):

1. Disable the drive. Set the rotary switches to one of the addresses 90 to 94 (see above table).

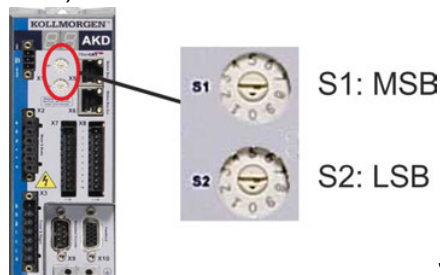

Set S1 to 9 and S2 to either 0 or 4

2. Push the button B1 on the AKD for at least 3 seconds until the rotary switch setting is displayed on the AKD-display.



3. When the display blinks with the set rotary switch setting stop pushing B1 and wait until the blinking stops. During that time the parameter FBUS.PARAM01 is set to the new value and all parameters are stored to the non volatile memory. The new setting will be taken with the next power-up of the drive.

If an error occurred, the following error messages will flash 5 times:

- E1 - Drive is enabled
- E2 - Non-volatile storage of the new setting failed
- E3 - Invalid rotary switch selection

8.19.3 Node Address for CAN-Bus

NOTE

After changing the node address, you must turn off the 24 V auxiliary supply for the drive and then turn it on again.

During setup, use the rotary switches on the AKD front panel to preset the station address for communication.

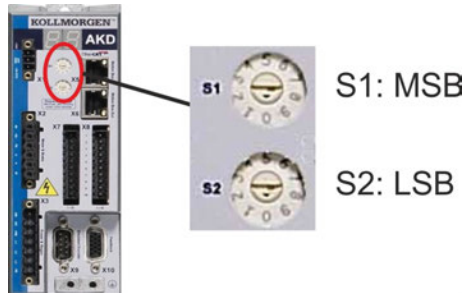

The rotary switches on the front of the AKD (S1&S2) correspond to the CAN node address. The S1&S2 switches also correspond to the IP address setting of the drive. Both CAN and IP network address schemes have to be configured to account for this dependence if both TCP/IP and CAN networks are running at the same time in an application. Example:

S1 (MSB)	S2 (LSB)	CAN address	IP address
4	5	45	192.168.0.45

The IP address setting can be decoupled from the Rotary switches using settings in the drive. Use Settings -> Fieldbus-> TCP/IP to adjust these settings.

8.19.4 CAN-Bus Termination

The last bus device on both ends of the CAN-Bus system must have termination resistors. The AKD has built-in 132 ohms resistors that can be activated by connecting pins 1 and 6. An optional termination plug is available for AKD (*P-AKD-CAN-TERM*). The optional termination plug is an RJ-12 connector with an enclosed wire jumper between pins 1&6. A plug should be inserted into the X13 connector of the last drive in the CAN network.

NOTE

Remove the termination connector if the AKD is not the last CAN-Bus device and use X13 for connecting the next CAN node.

8.19.5 CAN-Bus Cable

To meet ISO 11898, a bus cable with a characteristic impedance of 120 ohms should be used. The maximum usable cable length for reliable communication decreases with increasing transmission speed. As a guide, you can use the following values which Kollmorgen has measured; however, these values are not assured limits:

- Characteristic impedance: 100–120 ohms
- Cable capacitance max.: 60 nF/km
- Lead loop resistance: 159.8 ohms/km

Cable length, depending on the transmission rate:

Transmission Rate (kBaud)	Maximum Cable Length (m)
1,000	10
500	70
250	115

Lower cable capacitance (max. 30 nF/km) and lower lead resistance (loop resistance, 115 ohms/1000m) make it possible to achieve greater distances.

(Characteristic impedance 150 ± 5 ohms requires terminating resistor 150 ± 5 ohms).

8.19.6 CAN-Bus Wiring

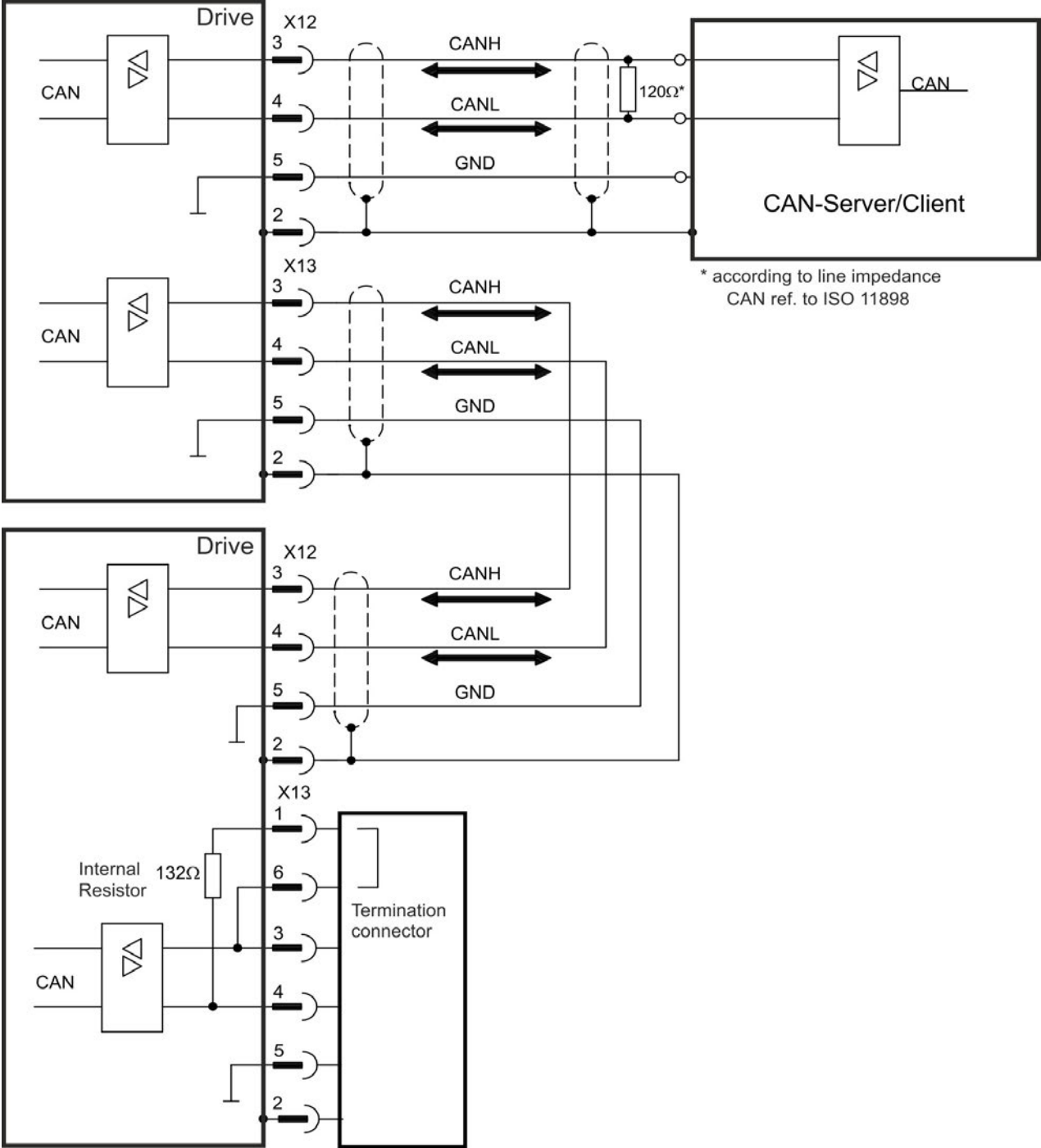

8.20 Motion Bus Interface (X5/X6/X11)

The motion bus interface has RJ-45 connectors and can be used for communicating with various fieldbus devices depending on the used drive version.

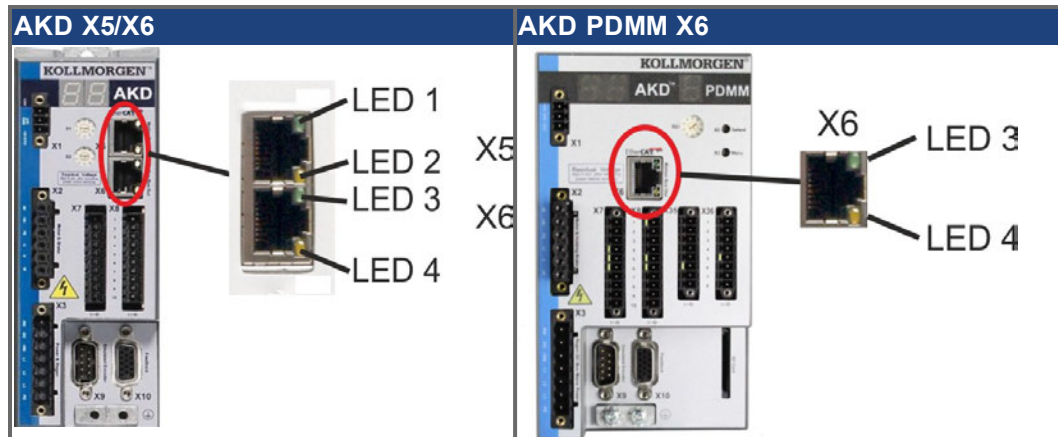

NOTICE

Do not connect the Ethernet line for the PC or PAC with the set up software to the motion bus interface X5/X6.

The set up Ethernet cable must be connected to X11 or X32.

8.20.1 Pinout X5, X6, X11

Pin	Signal X5	Signal X6	Signal X11
1	Transmit +	Receive+	Transmit +
2	Transmit -	Receive-	Transmit -
3	Receive+	Transmit +	Receive+
4, 5	n.c.	n.c.	n.c.
6	Receive-	Transmit -	Receive-
7, 8	n.c.	n.c.	n.c.

8.20.2 Bus Protocols X5, X6, X11

Protocol	Type	Connectivity Option	Connector
EtherCAT	Motion bus	EC or CC	X5, X6
SynqNet	Motion bus	SQ	X5, X6
sercos® III	Motion bus	S3	X5, X6
PROFINET RT	Motion bus	PN	X11
Ethernet/IP	Motion bus	EI	X11

8.20.3 EtherCAT

AKD drives (connection variants EC and CC) can be connected as slaves to the EtherCAT network (CoE) via RJ-45 connectors X5 (in port) and X6 (out port). The communication status is indicated by the built-in connector LEDs.

AKD PDMM drives (AKD-M) acts as an EtherCAT (CoE) master and therefore provides the X6 connector (out) for a string topology with 250 ms cycle time and maximum 8 slaves.

Drive variant	Connector	LED#	Name	Function
AKD	X5	LED1	IN port Link	ON = active, OFF= not active
		LED2	RUN	ON = running, OFF = not running
AKD and AKD PDMM	X6	LED3	OUT port Link	ON = active, OFF = not active
		LED4	-	-

8.20.3.1 EtherCAT activation with AKD-CC models

AKD-CC drive models are Drives, which support EtherCAT and CAN fieldbus types within one common software. CC drive models are delivered with EtherCAT set active. If you must change a drive from CANopen to EtherCAT, the DRV.TYPE parameter must be changed

1. by software: connect the PC to the AKD and change the parameter DRV.TYPE in the WorkBench terminal screen (see DRV.TYPE parameter documentation) or
2. by hardware: with the rotary switches S1 & S2 at the front and the button B1 on the top side of the Drive.

The following steps are needed for changing the fieldbus type from CAN to EtherCAT with the rotary switches.

1. Set the rotary switches on the front side of the AKD to the value of 89.

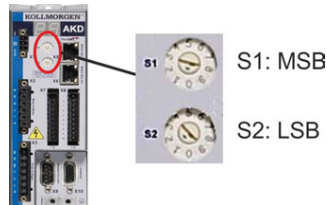

Set S1 to 8 and S2 to 9

2. Press the button B1 for about 3 seconds (starts DRV.NVSAVE).
Press B1 for 3 seconds.



The display shows **En** during the process of changing DRV.TYPE to EtherCAT.

Do not switch off the 24[V] power supply while the seven segment shows En!

3. Wait until the display returns to the original state, now the drive is prepared for EtherCAT.
4. Power cycle the drive by switching the 24 V power supply **off** and then **on** again.

NOTE

The seven segment display shows Er (Error) in case that the DRV.TYPE instruction failed. In this case please power cycle the drive and contact the Kollmorgen customer support for further help.

8.20.4 SynqNet

You can connect to the SynqNet Network via RJ-45 connectors X5 (in port) and X6 (out port). The communication status is indicated by the built-in LEDs.

Connector	LED#	Name	Function
X5	LED1	LINK_IN	ON = receive valid (IN port) OFF = not valid, power off, or reset.
	LED2	CYCLIC	ON = network cyclic BLINK = network not cyclic OFF = power off, or reset
X6	LED3	LINK_OUT	ON = receive valid (OUT port) OFF = not valid, power off, or reset
	LED4	REPEATER	ON = repeater on, network cyclic BLINK = repeater on, network not cyclic OFF = repeater off, power off, or reset

8.20.5 PROFINET

AKD with connectivity option **PN** can be connected to a PROFINET network via RJ-45 connector X11. PROFINET RT protocol is used. The communication status is indicated by the built-in LEDs.

Connector	LED#	Name	Function
X11	LED1	IN port Link	ON = active, OFF = not active
	LED2	RUN	ON = running, OFF = not running

Connect the service interface (X11) of the drive to an Ethernet interface on the PROFINET Master directly or via a network switch, **while the supply to the equipment is switched off**. Use standard Cat. 5 Ethernet cables for connection.

Confirm that the link LED on the AKD (the green LED on the RJ45 connector) and on your Master or Switch are both illuminated. If both lights are illuminated, then you have a good electrical connection.

The subnet mask of the AKD is 255.255.255.0. The first three octets of the drive's IP address must be the same as the first three octets of the HMI's IP address. The last octet must be different.

PROFINET RT and WorkBench can operate simultaneously if a switch is used.

8.20.6 Ethernet/IP

AKD with connectivity option **EI** can be connected to an Ethernet/IP network via RJ-45 connector X11. The communication status is indicated by the built-in LEDs.

Connector	LED#	Name	Function
X11	LED1	IN port Link	ON = active, OFF = not active
	LED2	RUN	ON = running, OFF = not running

Connect the service interface (X11) of the drive to an Ethernet interface on the Ethernet/IP Master directly or via a network switch, **while the supply to the equipment is switched off**. Use standard Cat. 5 Ethernet cables for connection.

Confirm that the link LED on the AKD (the green LED on the RJ45 connector) and on your Master or Switch are both illuminated. If both lights are illuminated, then you have a good electrical connection.

The subnet mask of the AKD is 255.255.255.0. The first three octets of the drive's IP address must be the same as the first three octets of the HMI's IP address. The last octet must be different.

Ethernet/IP and WorkBench can operate simultaneously if a switch is used.

8.20.7 sercos® III

AKD drives (connection variant S3) can be connected as slaves to the sercos® III network via RJ-45 connectors X5 (in port) and X6 (out port). Line and ring topologies are possible. The communication status is indicated by the built-in connector LEDs.

NOTE

Available from firmware revision 1.11, the protocol works with Hypertherm masters only.

Connector	LED#	Name	Function
X5	LED1	IN port Link	ON = active, OFF = not active
	LED2	RUN	ON = running, OFF = not running
X6	LED3	OUT port Link	ON = active, OFF = not active
	LED4	-	-

9 Setup

9.1 Important Notes	163
9.2 Setup AKD-B, AKD-P, AKD-T	164
9.3 Setup AKD-M	170
9.4 Fault and Warning Messages	180
9.5 Troubleshooting the AKD	194

9.1 Important Notes

NOTE

Before testing and setup, the manufacturer of the machine must generate a risk assessment for the machine and take appropriate measures so that unforeseen movements cannot cause injury or damage to any person or property.

Only professional personnel with extensive knowledge in the fields of electrical engineering and drive technology are allowed to test and set up the drive.



DANGER

The equipment produces potentially lethal voltages up to 900 V. Risk of electrical shock. Check that all connection components that are live in operation are safely protected against bodily contact.

Never remove the electrical connections to the drive while it is live.

Capacitors can still have dangerous residual charges up to 7 minutes after switching off the supply voltage.



WARNING

The drive might restart automatically after power on, depending on the parameter setting. Risk of death or serious injury for humans working in the machine. If parameter DRV.ENDEFAULT is set to 1, then place a warning sign to the machine (Warning: Automatic Restart at Power On) and ensure, that power on is not possible, while humans are in a dangerous zone of the machine.



CAUTION

The heat sink of the drive can reach temperatures up to 80°C in operation. Risk of light burns. Check the heat sink temperature before handling the drive. Wait until the heat sink has cooled down to 40 °C before touching it.

NOTICE

If the drive has been stored for more than 1 year, you must re-form the capacitors in the DC bus link circuit. To re-form the capacitors, disconnect all electrical connections and apply single-phase 208 to 240 VAC to terminals L1/L2 of the drive for about 30 minutes.

NOTE

Additional information on setting up the equipment:

- Programming parameters and control loop behavior are described in the online help of the setup software.
- The setup of any expansion card described in the corresponding manual on the DVD.
- Kollmorgen can provide training courses for the drive upon request.

9.2 Setup AKD-B, AKD-P, AKD-T

9.2.1 Setup software WorkBench

This chapter describes the installation of the setup software WorkBench for AKD-B, AKD-P and AKD-T drives. WorkBench is not used for setting up the AKD-M (AKD PDMM), for this drive variant the KAS IDE software must be used (→ p. 170).

Kollmorgen offers training and familiarization courses on request.

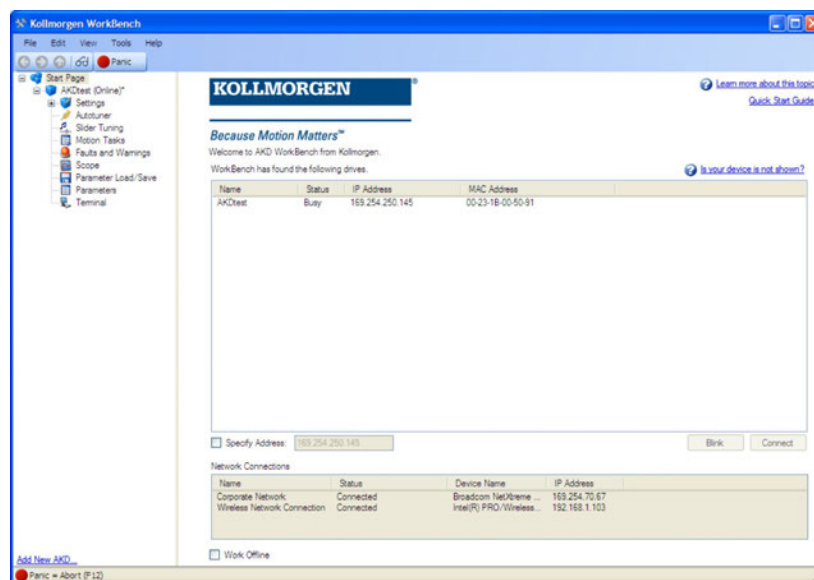

9.2.2 Use as directed

The setup software is intended to be used for altering and saving the operating parameters for the AKD series of drives. The attached drive can be set up with the help of this software, and during this procedure the drive can be controlled directly by the service functions.

Only professional personnel who have the relevant expertise (→ p. 15) are permitted to carry out online parameter setting for a drive that is running. Sets of data that have been stored on data media are not safe against unintended alteration by other persons. Unexpected move could be the result if you use unchecked data. After loading a set of data you must therefore always check all parameters before enabling the drive.

9.2.3 Software description

Each drive must be adapted to the requirements of your machine. For most applications, you can use a PC and WorkBench (the drive setup software) to set up the operating conditions and parameters for your drive. The PC is connected to the drive by an Ethernet cable (→ p. 149). The setup software provides the communication between the PC and AKD. You can find the setup software on the accompanying DVD and in the download area of the Kollmorgen website.

With very little effort you can alter parameters and instantly observe the effect on the drive, since there is a continuous (online) connection to the drive. You can also read important actual values from the drive, which are displayed on the monitor of the PC (oscilloscope functions).

You can save sets of data on data media (archiving) and load them into other drives or use them for backup. You can also print out the data sets.

Most standard feedbacks (SFD, EnDAT 2.2, 2.1, and BiSS) are plug and play compatible. Motor nameplate data is stored in the feedback device and read by the drive automatically at startup. Non-plug and play Kollmorgen motors are stored in WorkBench and can be loaded with one-click using the Motor screen in the WorkBench software.

An extensive online help with integrated description of all variables and functions supports you in each situation.

9.2.4 Hardware requirements

The Service interface (X11, RJ45) of the drive is connected to the Ethernet interface of the PC by an Ethernet cable (→ p. 149).

Minimum requirements for the PC:

Processor: at least Pentium® II or comparable
 Operating system : Windows 2000 or XP or VISTA or 7
 Graphics adapter : Windows compatible, color
 Drives : hard disk with at least 20 MB free space, DVD drive
 Interface : one free Ethernet Interface, or a Hub port or Switch port

9.2.5 Operating systems

Windows 2000/XP/VISTA/7

WorkBench works with Windows 2000, Windows XP, Windows VISTA and Windows 7

Unix, Linux

The functioning of the software has not been tested for Windows running with Unix or Linux.

9.2.6 Installation under Windows 2000/XP/VISTA/7

The DVD includes an installation program for the setup software.

Installation

- Autostart function activated:
Insert the DVD into a free drive. A window with the start screen opens. There you find a link to the setup software WorkBench. Click it and follow the instructions.
- Autostart function deactivated:
Insert the DVD into a free drive. Click **Start** (task bar), then **Run**. Enter the program call: x:\index.htm (x = correct DVD drive letter).
Click **OK** and proceed as described above.

Connection to the Ethernet interface of the PC

- Connect the interface cable to an Ethernet interface on your PC or to a Hub/Switch and to the service interface X11 of the AKD (→ p. 149).

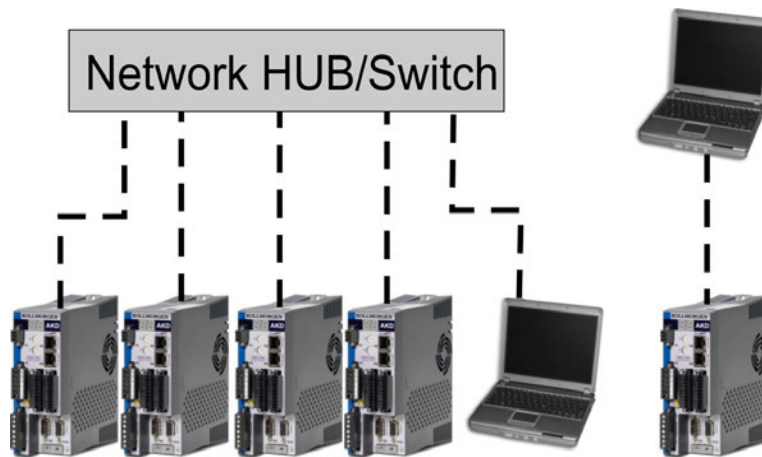

9.2.7 Initial Drive Test AKD-B, AKD-P, AKD-T

9.2.7.1 Unpacking, mounting, and wiring the AKD

- Unpack the drive and accessories. Observe the safety instructions in the documentation.
- Mount the drive.
- Wire the drive or apply the minimum wiring for drive testing as described below.
- Make sure you have on hand the following information about the drive components:
 - rated mains supply voltage
 - motor type (motor data, if the motor type is not listed in the motor database)
 - feedback unit built into the motor (type, poles/lines/protocol)
 - moment of inertia of the load

9.2.7.2 Minimum wiring for drive test without load

NOTICE

This wiring diagram is for general illustration only and does not fulfill any requirements for EMC, safety, or functionality of your application.

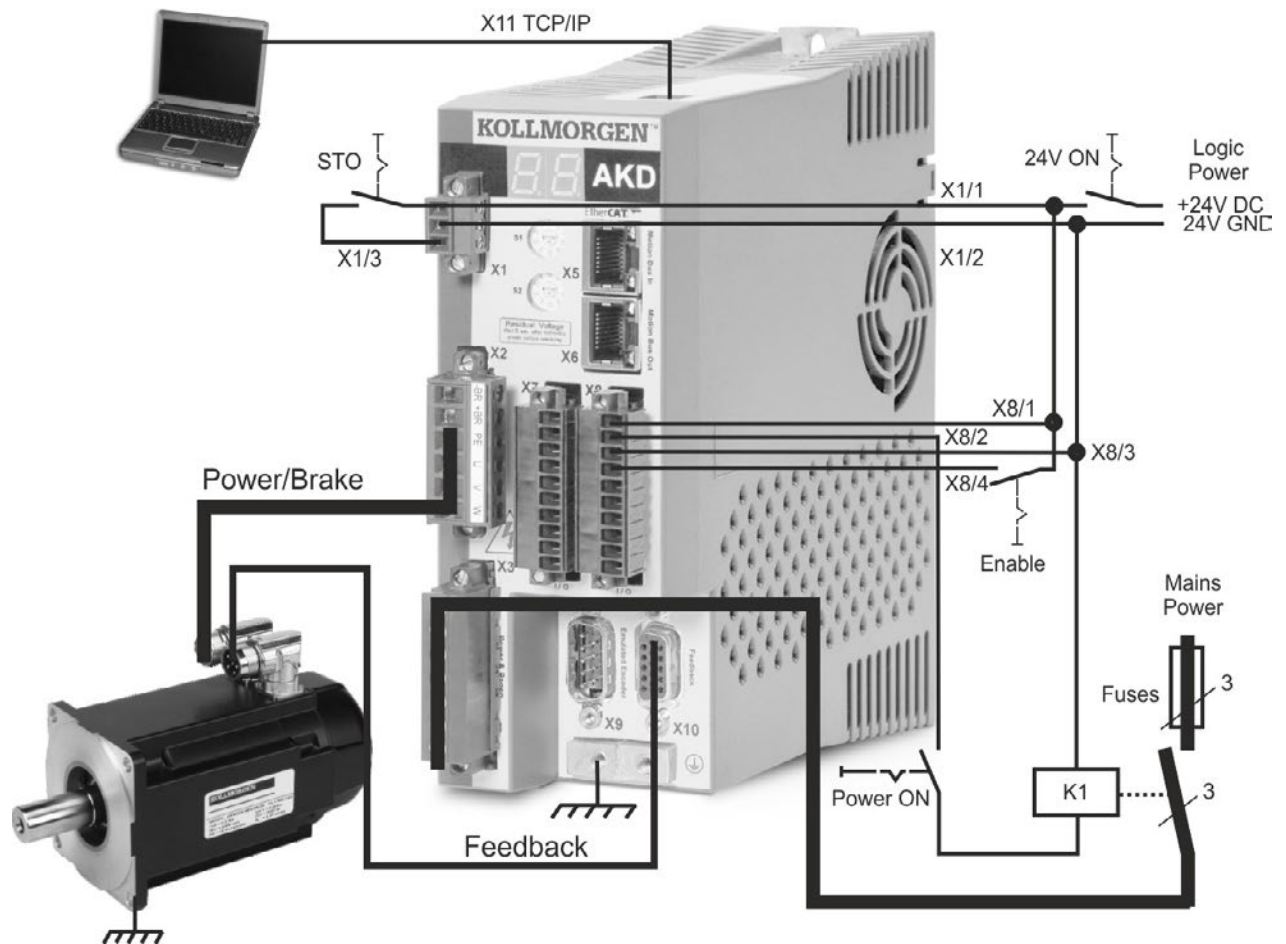

When connecting the AKD directly to a PC, static IP addressing (not 00) is recommended.

9.2.7.3 Set IP address

Set the drive IP address as described in "Setting the IP Address AKD-B, AKD-P, AKD-T" (→ p. 150).

9.2.7.4 Confirm connections

You can turn on logic power to the drive through the X1 connector (bus voltage is not needed for communications).

After power is supplied, the drive displays a sequence of LED flashes (see WorkBench Onlinehelp for details):

1. –
2. []
3.] [
4. I-P
5. Drive IP address, flashed sequentially (for example, 192.168.0.25).
6. Drive status (opmode "o0", "o1", or "o2") or fault code if the drive is in a fault condition.

Confirm that the link LEDs on the drive (green LED on the RJ45 connector) and on your PC are both illuminated. If both LEDs are illuminated, then you have a working electrical connection.



While the PC is connecting, your statusbar will show the following acquiring icon:



Wait for this icon to change to the limited functionality icon (this process can take up to one minute).



Although Windows displays this limited functionality icon for the drive connection, the PC can communicate fully with the drive. Using WorkBench, you can now configure the drive through this connection.

9.2.7.5 Install and start WorkBench

WorkBench installs automatically from the DVD included with the drive. WorkBench is also available on the Kollmorgen Web site: www.kollmorgen.com.

Once installation is complete, click the WorkBench icon to start the program. WorkBench will show a list of all the drives that it can find on your local network. Select the drive you wish to configure and then click **Next**.

If multiple drives are detected, a drive can be uniquely identified using one of the following methods:

1. The MAC address of the drive. This address is printed on the sticker on the side of the drive.
2. The name of the drive. The drive name is set using WorkBench. A new drive defaults to "No_Name."
3. Blinking the display. Select a drive and click **Blink** to force the display on the front of the drive to blink on and off for 20 seconds.

9.2.7.6 Set drive IP address in WorkBench

If WorkBench does not automatically show your drive, then you can set the IP address manually in WorkBench as follows:

1. Display the IP address. You can show the drive IP address on the drive display by pressing button B1. The display shows the digits and dots of the IP address in sequence (for example, 192.168.0.25).



2. Enter the drive IP address. Once the IP address has been determined, manually enter the drive IP address into the **Specify Address** box in WorkBench. Then click **Next** to connect.

9.2.7.7 Enable the drive using the setup wizard

Once a connection to the drive has been established, the AKD Overview screen appears. Your drive appears in the navigation area on the left of the screen. Right click on your drive name and select **Setup Wizard** from the drop-down menu. The Setup Wizard guides you through the initial drive configuration, which includes a simple test motion.

After completing the Setup Wizard, your drive should be enabled. If the drive is not enabled, check the following:

1. The hardware enable (HW) must be in the enabled state (pin 4 on X8 connector).
2. The software enable (SW) must be in the enabled state. Activate using the **Enable/Disable** button on the upper toolbar on WorkBench or in the Overview screen.
3. No faults may be present (click the **Clear Fault** button on the upper tool bar to clear any faults).

The status of HW enable, SW enable, and Faults is displayed in the lower toolbar of the WorkBench software. The drive is connected if the lower right corner shows **Online**.

You can now use the Settings View in WorkBench to complete advanced configuration of your drive.

9.3 Setup AKD-M

9.3.1 Setup software KAS IDE

This chapter describes the installation of the setup software KAS IDE for the AKD-M (AKD PDMM) drives. KAS IDE is not used for setting up the AKD-B, AKD-P and AKD-T drives, for these drive variants the WorkBench software must be used (→ p. 164).

The KAS IDE integrated development environment contains tools for configuring the Ether-CAT Network, setup and tuning the drives, creating a PLC program, and creating an HMI. Kollmorgen offers training and familiarization courses on request.

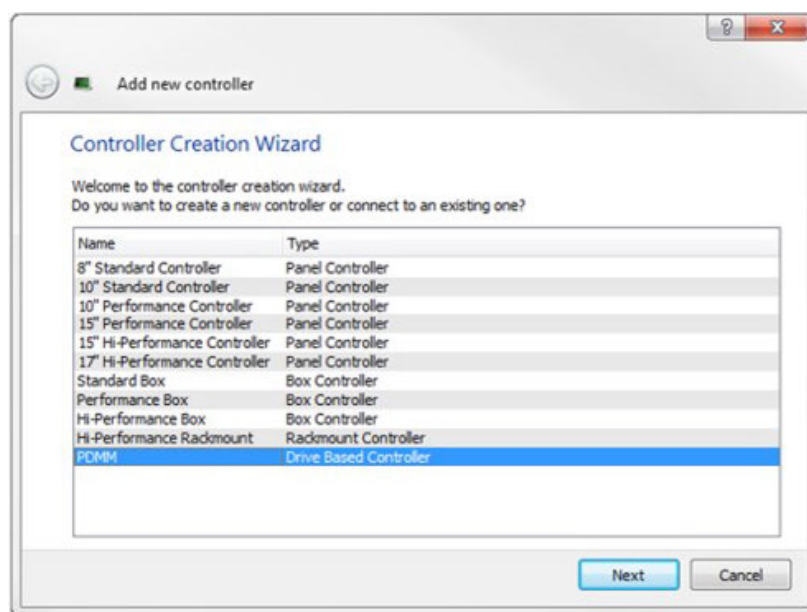

9.3.2 Use as directed

The setup software is intended to be used for altering and saving the operating parameters for the AKD PDMM series of drives. The attached drive can be set up with the help of this software, and during this procedure the drive can be controlled directly by the service functions.

Only professional personnel who have the relevant expertise (→ p. 15) are permitted to carry out online parameter setting for a drive that is running. Sets of data that have been stored on data media are not safe against unintended alteration by other persons. Unexpected move could be the result if you use unchecked data. After loading a set of data you must therefore always check all parameters before enabling the drive.

9.3.3 Software description

Each drive must be adapted to the requirements of your machine. For most applications, you can use a PC and KAS IDE software ("Kollmorgen Automation Suite Integrated development environment) to set up the operating conditions and parameters for your drive. The PC is connected to the drive by an Ethernet cable (→ p. 149). The setup software provides the communication between the PC and AKD PDMM. You can find the KAS IDE setup software on the accompanying DVD and in the download area of the Kollmorgen website.

With very little effort you can alter parameters and instantly observe the effect on the drive, since there is a continuous (online) connection to the drive. You can also read important actual values from the drive, which are displayed on the monitor of the PC (oscilloscope functions).

You can save sets of data on data media (archiving) and load them into other drives or use them for backup. You can also print out the data sets.

Most standard feedbacks (SFD, EnDAT 2.2, 2.1, and BiSS) are plug and play compatible. Motor nameplate data is stored in the feedback device and read by the drive automatically at startup. Non-plug and play Kollmorgen motors are stored in KAS IDE and can be loaded with one-click using the Motor screen in the KAS IDE software.

An extensive online help with integrated description of all variables and functions supports you in each situation.

9.3.4 Hardware requirements

The Service interface (X32, RJ45) of the drive is connected to the Ethernet interface of the PC by an Ethernet cable (→ p. 149).

Minimum requirements for the PC:

Processor: at least Pentium® II or higher

Operating system : Windows XP or 7

Graphics adapter : Windows compatible, color

Drives : hard disk with at least 20 MB free space, DVD drive

Interface : one free Ethernet Interface, or a Hub port or Switch port

9.3.5 Operating systems

Windows XP/7

KAS IDE works with Windows XP and Windows 7

Unix, Linux

The functioning of the software has not been tested for Windows running within Unix or Linux.

9.3.6 Installation under Windows XP/7

The DVD includes an installation program for the setup software.

Installation

- Autostart function activated:
Insert the DVD into a free drive. A window with the start screen opens. There you find a link to the setup software KAS IDE. Click it and follow the instructions.
- Autostart function deactivated:
Insert the DVD into a free drive. Click **Start** (task bar), then **Run**. Enter the program call: x:\index.htm (x = correct DVD drive letter).
Click **OK** and proceed as described above.

Connection to the Ethernet interface of the PC

- Connect the interface cable to an Ethernet interface on your PC or to a Hub/Switch and to the service interface X32 of the AKD PDMM (→ p. 149).

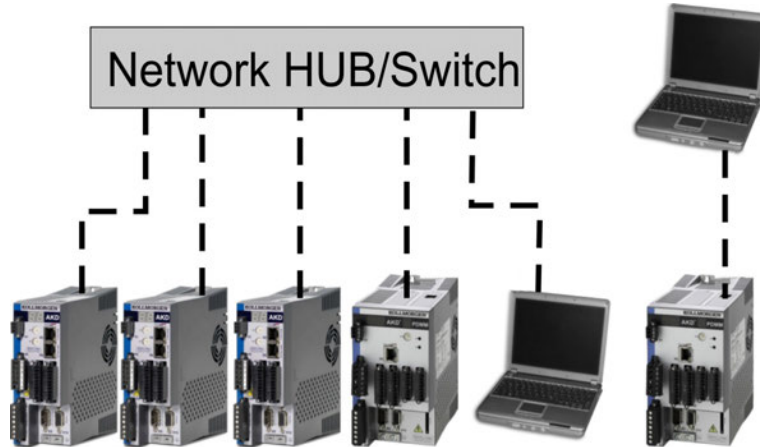

9.3.7 Initial Drive Test AKD-M

9.3.7.1 Unpacking, mounting, and wiring the AKD PDMM

- Unpack the drive and accessories. Observe the safety instructions in the documentation.
- Mount the drive.
- Wire the drive or apply the minimum wiring for drive testing as described below.
- Make sure you have on hand the following information about the drive components:
 - rated mains supply voltage
 - motor type (motor data, if the motor type is not listed in the motor database)
 - feedback unit built into the motor (type, poles/lines/protocol)
 - moment of inertia of the load

9.3.7.2 Minimum wiring for drive test without load

NOTICE

This wiring diagram is for general illustration only and does not fulfill any requirements for EMC, safety, or functionality of your application.

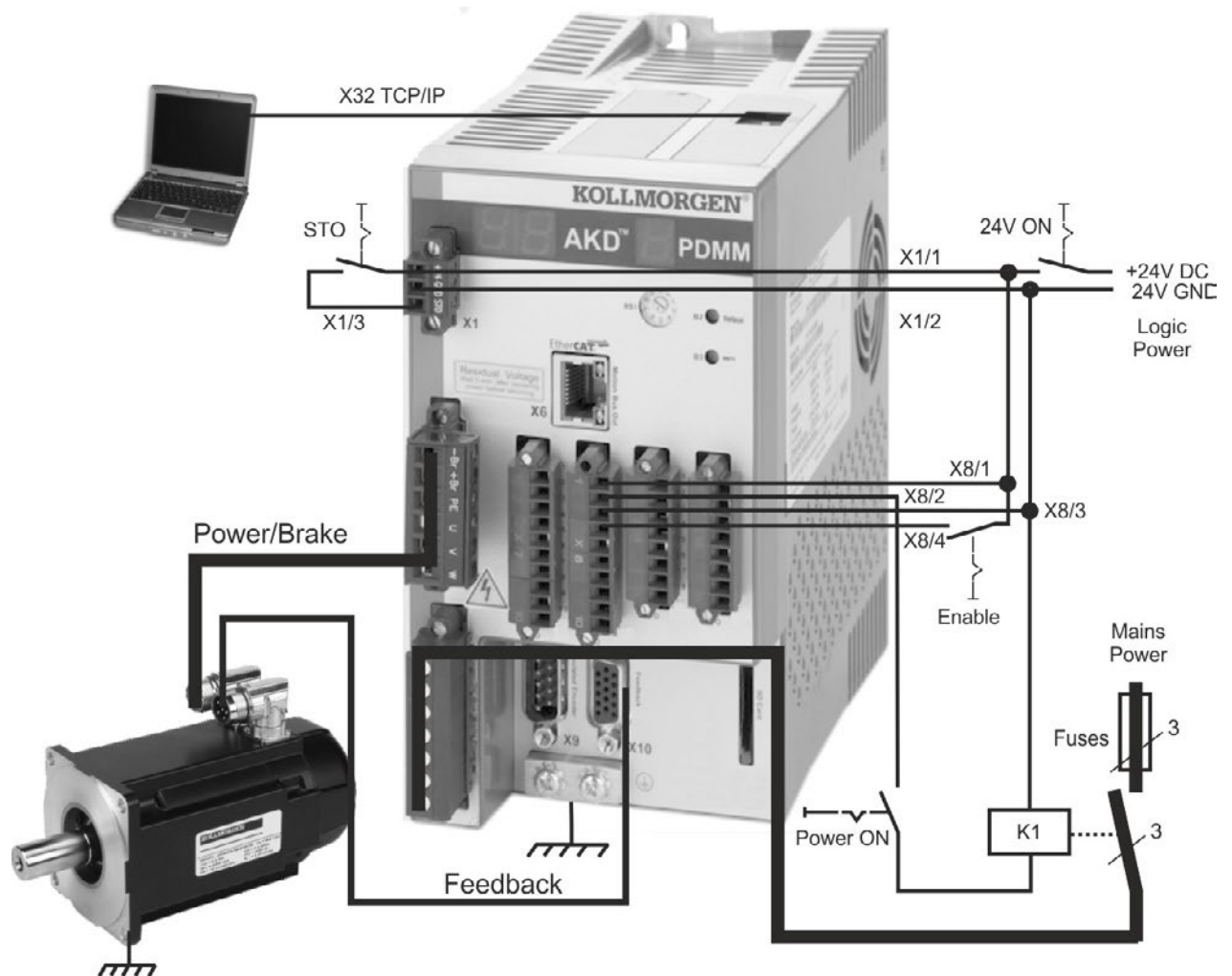

When connecting the AKD PDMM directly to a PC, static IP addressing (not 0) is recommended.

9.3.7.3 Set IP address

Set the drive IP address as described in "Setting the IP Address AKD-M" (→ p. 152).

9.3.7.4 Confirm connections

You can turn on logic power to the drive through the X1 connector (bus voltage is not needed for communications).

After power is supplied, the drive displays a sequence of LED flashes:

AKD-M two + one digits



--	Power on	-	Power on
o#	Drive opmode # not enabled	- to O	Initialization sequence
o#.	Drive opmode # enabled	IP_	IP address
see WorkBench Onlinehelp for details.		o	Operational - program not running
		o.	Operational - program running

Confirm that the link LEDs on the drive (green LED on the RJ45 connector X32) and on your PC are both illuminated. If both LEDs are illuminated, then you have a working electrical connection.

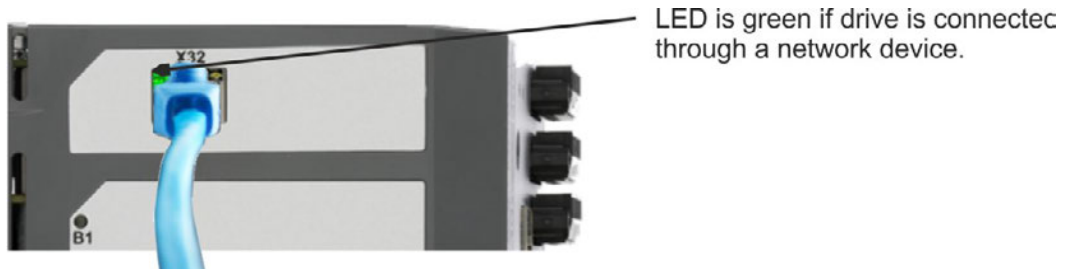

While the PC is connecting, your statusbar will show the following acquiring icon:



Wait for this icon to change to the limited functionality icon (this process can take up to one minute).



Although Windows displays this limited functionality icon for the drive connection, the PC can communicate fully with the drive. Using KAS IDE, you can now configure the drive through this connection.

9.3.7.5 Install and start KAS IDE

The KAS IDE is included on the DVD that came with the AKD PDMM, as well as online at www.kollmorgen.com. Insert the DVD and wait for installer to auto-start. Once installation is complete, click the KAS IDE icon to start the program.

Begin a new project by selecting **File > New**. This will launch the **Add a New Controller** window. Select your AKD PDMM model from the list. The controller will then be added to the project view.

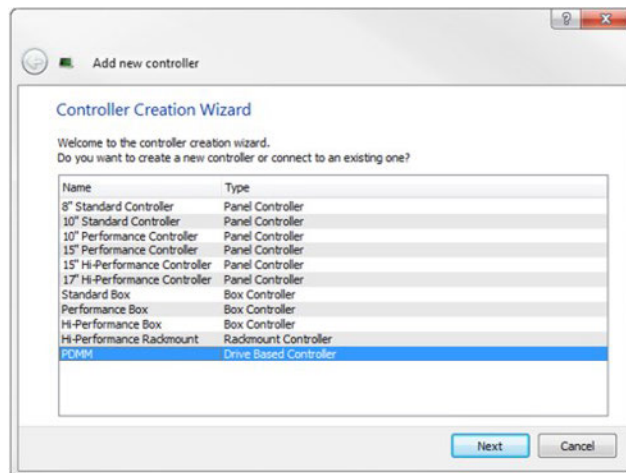

To associate the project with an IP address of the AKD PDMM controller, right click on the Controller option in the Project View. Select **Properties** and the following screen appears:

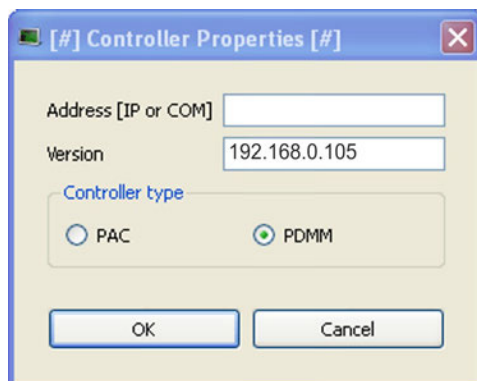

Type in the IP address of the AKD PDMM, set the **Controller Type** to PDMM and click OK. To connect to the PDMM, download, and run the project use the following controls:



Double click on EtherCAT in the project view to open the EtherCAT devices view. Click on scan devices in the upper-right corner, and the KAS IDE will automatically identify and add your drive.

If multiple drives are detected, a drive can be uniquely identified using one of the following methods:

1. The MAC address of the drive. This is printed on the sticker on the side of the drive.
2. The name of the drive. The drive name is set using KAS IDE. A new drive defaults to "No_Name."
3. Blinking the display. Select a drive and click Blink to force the display on the front of the drive to blink on and off for 20 seconds.

9.3.7.6 Set drive IP address in KAS IDE

If KAS IDE does not automatically show your drive, then you can set the IP address manually in KAS IDE as follows:

1. Display the IP address. You can show the drive IP address on the drive display by starting the menu with button B2 and selecting "IP" by pressing B2 again. The display shows the digits and dots of the IP address in sequence (for example, 192.168.0.105).
2. The IP address of the AKD PDMM is setup in the project file inside the KAS IDE. To see the IP address, open a project or create a new project. Right click on the Project Explorer/Project view Controller item and select **Properties**.

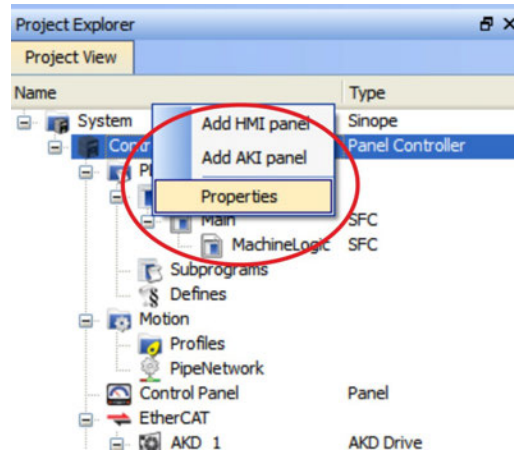

3. Type in the AKD PDMM address as follows:

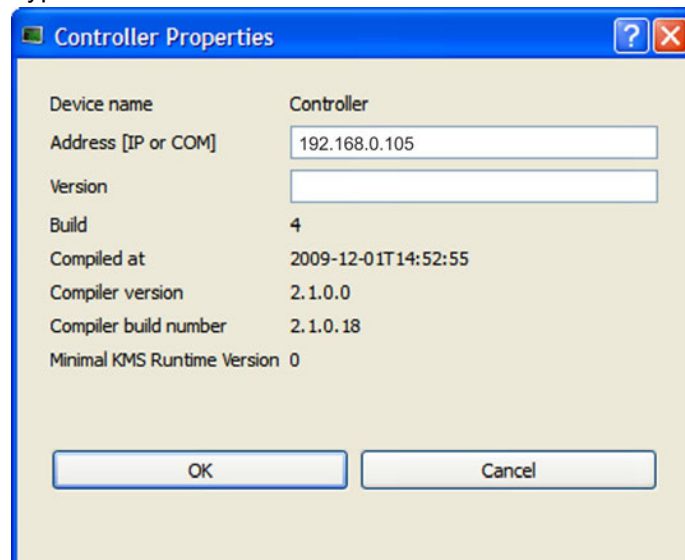

9.3.7.7 Starting new project

Once a project (new or saved) is opened from the Project Explorer, you can open a variety of items to build a project:

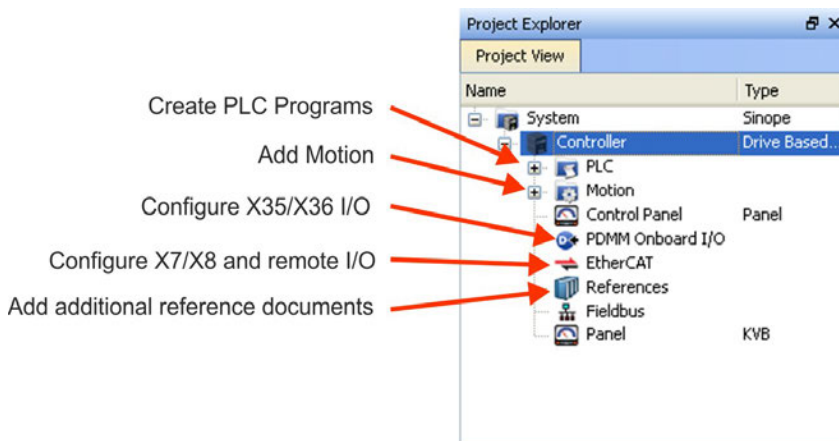

All drives, including the drive in the AKD PDMM itself, and the Remote I/O can be configured by the KAS IDE.

Add the drives to the project: click on the EtherCAT item and scan for devices (1).

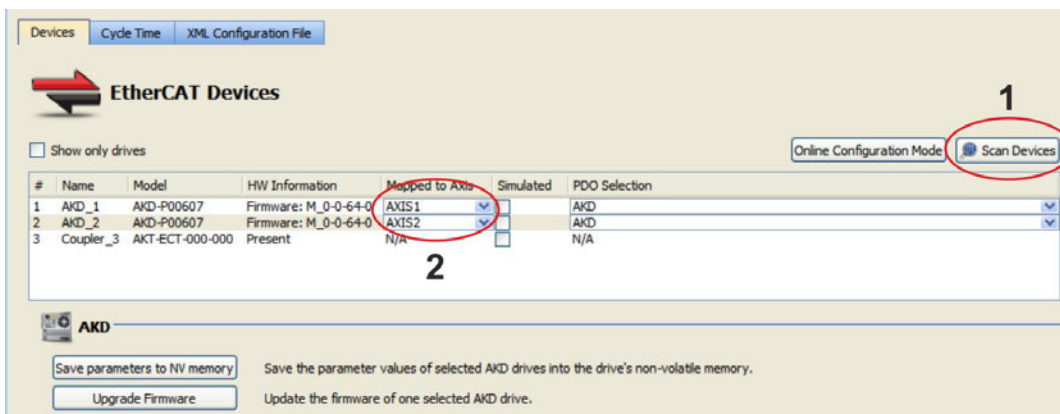

Map the detected drives to axis of your application (2). All detected items are automatically added to your project:

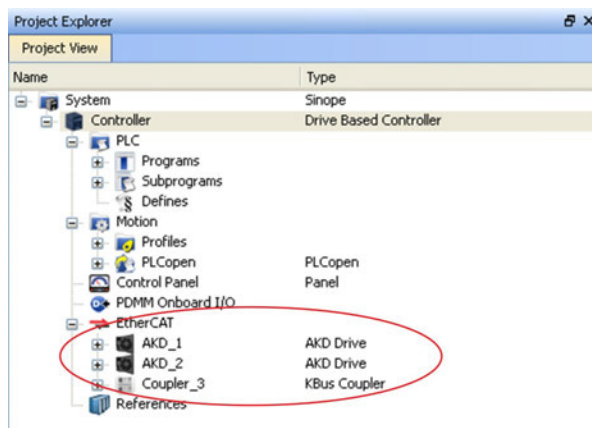

To communicate directly with a drive without running a project click on the EtherCAT item in the project tree. Click on the drive in the project tree to configure (1), then click on the **Online Configuration** button (2):

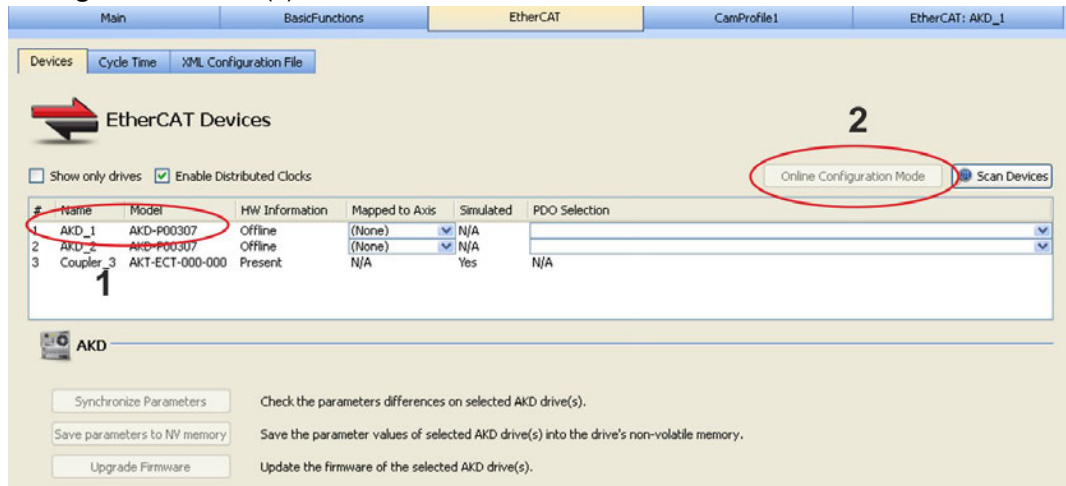

In the work space a set of screens opens up that enable you to completely configure the drive:

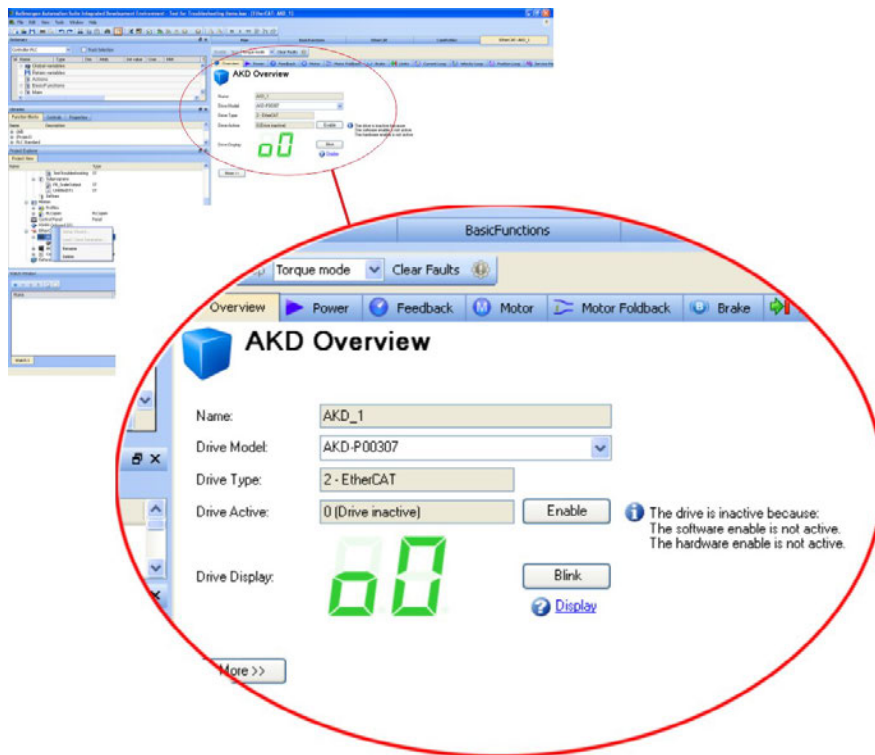

Additionally the setup wizard will take you through a set of steps to perform the configuration:

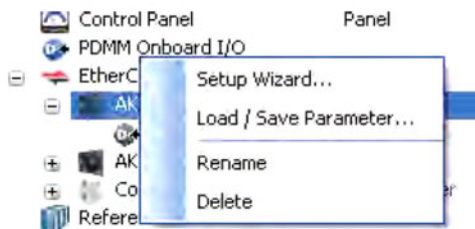

To perform basic motion without running a project the **Service Motion** screen can be used.

Enable Stop **Position mode** Clear Faults

Limits Current Loop Velocity Loop Position Loop **Service Motion**

Service Motion

Service motion allows you to start and stop some test motions.

Service Motion Mode: Pulse Reversing Continuous

Velocity 1: rpm

0

Time 1: ms

Acceleration: rpm/s

Deceleration: rpm/s

Drive is inactive.

Position Feedback: Counts16Bit

Velocity Feedback: rpm

No Faults Drive Inactive SW HW Not Connected

9.4 Fault and Warning Messages

9.4.1 Fault and warning messages AKD

When a fault occurs, the drive fault relay is opened, the output stage is switched off (motor loses all torque), or the load is dynamically braked. The specific drive behavior depends on the type of fault. The LED display on the front panel of the drive shows the number of the fault that occurred. If a warning is issued prior to the fault, the warning is shown on the LED and has the same number as the associated fault. Warnings do not trip the power stage of the drive or fault relay output.



AKD fault codes or warning codes are displayed constantly if present. Fault messages are coded with "F", warnings are coded with "n". With built-in I/O option card, SD card operation errors are displayed with "E" followed by 4 digits.

The left side of the LED displays F (or E) for a fault or n for a warning. The right side displays the fault or warning number as follows: 1-0-1-[break]. The highest priority fault is displayed. Multiple faults may be present when a fault condition is occurring. Check the AKD Work-Bench Fault Screen or read the status of DRV.FAULTS through the controller or HMI for the entire list of faults.

NOTE

More information about fault messages, remedy and clearing faults can be found in the Work-Bench online help.

Fault	Message/Warning	Cause
..		24V Control Power input voltage dip. or Auxiliary encoder 5V (X9-9) shorted.
E0082	SD Card is not inserted.	No SD card inserted or SD card inserted with wrong orientation.
E0083	SD Card is write protected.	SD card protection clip in wrong position.
E0084	SD Card hardware not installed.	No I/O option board installed or SD card device faulty.
E0095	File not found on SD Card.	SD card damaged or filename has been changed manually or deleted.
E0096	File error trying to access the SD Card.	File on SD card can't be read.
E0097	File system error accessing the SD card.	File system on SD card can't be read.
E0098	A parameter could not be set in the drive.	-
E0099	There was an error writing to a file on the SD Card.	General writing error.
E0100	SD Card read/write in progress.	-
E0101	There was an error accessing the BASIC binary file.	Basic program file couldn't be read.
F0		Reserved.
F101	Firmware incompatible.	Installed firmware is not compatible with the drive hardware.
n101	The FPGA is a lab FPGA.	The FPGA is a lab version FPGA.
F102	Resident firmware failed.	Software failure detected.

Fault	Message/Warning	Cause
n102	Operational FPGA is not a default FPGA.	The FPGA minor version is larger than the operational firmware default FPGA minor version
F103	Resident FPGA failed.	Software failure detected. Load resident FPGA failure occurred (several cases according to flowchart, including incompatible image to FPGA type and fieldbus type).
F104	Operational FPGA failed.	Software failure detected. Load operational FPGA failure occurred (several cases according to flowchart).
F105	Non-volatile memory stamp invalid.	Non-volatile memory stamp is corrupted or invalid.
F106	Non-volatile memory data	Non-volatile memory data is corrupted or invalid. When this fault occurs after a firmware download, it is not an indication of a problem (clear the fault and perform a "save" to the drive).
n107	Positive switch limit exceeded.	Positive software position limit is exceeded.
n108	Negative switch limit exceeded.	Negative software position limit is exceeded.
F121	Homing error.	Drive did not finish homing sequence.
F123 n123	Invalid motion task.	Invalid motion task.
F125 n125	Synchronization lost.	The fieldbus lost synchronization.
F126 n126	Too much movement.	Too much movement was created during a Bode plot. Motor is unstable and is not following drive instructions.
F128	MPOLES/FPOLES not an integer.	Ratio of motor poles to feedback poles must be a whole number.
F129	Heartbeat lost.	Heartbeat lost.
F130	Secondary feedback supply over current.	5V power supply was shorted out on X9.
F131	Secondary feedback A/B line break.	Problem in secondary feedback detected.
F132	Secondary feedback Z line break.	Problem in secondary feedback detected.
F133	Fault number changed to F138. See F138 for details.	
F134	Secondary feedback illegal state.	Feedback signals were detected in an illegal combination.
F135 n135	Homing is needed.	Attempt to issue motion task before the axis is homed. Axis must be homed before motion task can start.
F136	Firmware and FPGA versions are not compatible	The FPGA version does not match the firmware FPGA version constants.
n137	Homing and feedback mismatch	The configured homing mode is not supported by the motor feedback type used.
F138	Instability during autotune	Drive current (IL.CMD) or velocity feedback (VL.FB) exceeds allowable limit (BODE.IFLIMIT or BODE.VFLIMIT). Occurs in BODE.MODE 5, when complex mechanics, belts, and compliant loads are present.
F139	Target Position Overshot due to invalid Motion task activation.	The drive cannot decelerate from its current speed to reach the end point of the second motion task without moving past it.

Fault	Message/Warning	Cause
n151	Not enough distance to move; motion exception.	For trapezoidal and customer table motion tasks: The target velocity specified in the motion task cannot be reached via using the selected acceleration and deceleration since the distance to travel is not sufficient. For a 1:1 profile: The selected acceleration and deceleration will be extended since there is too much distance to travel and the motion task would exceed its maximum allowed velocity.
n152	Not enough distance to move; following motion exception.	A new motion task activated, when one motion task is already active and the target position specified in the motion task parameters cannot be reached with specified target velocity, acceleration and deceleration parameters.
n153	Velocity limit violation, exceeding max limit.	A new target velocity calculated internally due to an exception, and is being limited due to user velocity limit.
n154	Following motion failed; check motion parameters.	Activation of the following motion task failed due to incompatible parameters, or motion task does not exist.
n156	Target position crossed due to stop command.	The motion task crosses the target position after triggering a DRV.STOP command. This situation can happen when processing a change-on-the-fly motion task and triggering a DRV.STOP command close to the target position of the currently running motion task.
n157	Homing index pulse not found.	A homing mode with index detection is activated, and index pulse is not detected while moving across the range determined by the hardware limit switches.
n158	Homing reference switch not found.	A homing mode with reference switch detection is activated and the reference switch is not detected while moving across the range determined by the hardware limit switches.
n159	Failed to set motion task parameters	Invalid motion task parameters assignment. This warning can appear upon an MT.SET command.
n160	Motion task activation failed.	Activation of the motion task failed due to incompatible parameters, or motion task does not exist. This warning can appear upon an MT.MOVE command.
n161	Homing procedure failed.	Homing error observed during the operation of homing procedure.
n163	MT.NUM exceeds limit.	Appears with n160, when you try to trigger a motion task > 128 (such as MT.MOVE 130).
n164	Motion task is not initialized.	Appears with n160, when you try to trigger a non-initialized motion task.
n165	Motion task target position is out.	Appears with n160, when you try to trigger a motion task with an absolute target position outside of the selected modulo range (see also MT.CNTL).
n167	SW limit switch traversed	
n168	Invalid bit combination in the motion task control word.	Appears with n160, when you try to trigger a motion task with an invalid bit combination in the motion task control word (see also MT.CNTL).

Fault	Message/Warning	Cause
n169	1:1 profile cannot be triggered on the fly.	Appears with n160, when you try to trigger a 1:1 profile table motion task while another motion task is currently running.
n170	Customer profile table is not initialized.	Appears with n160, when you try to trigger a motion task that uses a customer profile table for generating the velocity profile and when the selected profile table is empty (see MT.CNTL and MT.TNUM).
n171	Motion task activation is currently pending	text in process
n174	Homing maximum distance exceeded	text in process
F201	Internal RAM failed.	Hardware failure detected.
F202	External RAM failed.	Hardware failure detected.
F203	Code integrity failed.	Software failure detected. FPGA register access failure occurred.
F204 to F232	EEPROM failure detected	EEPROM failure detected
F234 to F237 n234 to n237	Temperature sensor high.	High temperature limit reached.
F240 to F243 n240 to n243	Temperature sensor low.	Low temperature limit reached.
F245	External fault.	This fault is user generated and is caused by user settings.
F247	Bus voltage exceed allowed thresholds.	Hardware problem in bus measurement.
F248	Option board EEPROM corrupted.	EEPROM failure detected.
F249	Option board downstream checksum.	Communications with the I/O on the option board failed.
F250	Option board upstream checksum.	Communications with the I/O on the option board failed.
F251	Option board watchdog.	Communications with the I/O on the option board failed.
F252	Firmware and option board FPGA types are not compatible.	The option board FPGA is not compatible with this hardware.
F253	Firmware and option board FPGA versions are not compatible.	The version of the option board FPGA is not compatible with this firmware.
F301 n301	Motor overheated.	Motor overheated.
F302	Over speed.	Motor exceeded VL.THRESH value.
F303	Runaway.	Motor did not follow command values.
F304 n304	Motor foldback.	Maximum motor power has been exceeded; the power has been limited to protect the motor
F305	Brake open circuit.	Motor brake open circuit. Fault threshold is 200 mA.
F306	Brake short circuit.	Motor brake short circuit.
F307	Brake closed during enable state.	Motor brake closed unexpectedly.
F308	Voltage exceeds motor rating.	Drive bus voltage exceeds the motor's defined voltage rating.
n309	Motor I ² t load.	Motor I2t load (IL.MI2T) has exceeded the warning threshold IL.MI2TWITHRESH. Can only be generated if IL.MIMODE has been set to 1.

Fault	Message/Warning	Cause
F312	Brake released when it should be applied.	Brake disengaged unexpectedly.
F401	Failed to set feedback type.	Feedback is not connected or wrong feedback type selected
F402	Analog signal amplitude fault.	Analog signal amplitude is too low. Analog fault (resolver signal or sin/cos amplitude)
F403	EnDat communication fault.	General communication problem with feedback.
F404	Hall error.	Hall sensor returns invalid Hall state (111, 000); either all Hall sensors are on or off. Can be caused by a broken connection in any one of the Hall signals.
F405	BiSS watchdog fault.	Bad communication with the feedback device.
F406	BiSS multicycle fault.	
F407	BiSS sensor fault.	
F408 to F416	SFD feedback fault.	Bad communication with the SFD device.
F417	Broken wire in primary feedback.	In primary feedback, a broken wire was detected (incremental encoder signal amplitude).
F418	Primary feedback power supply.	Power supply fault for primary feedback.
F419	Encoder init procedure failed	Phase find procedure did not complete successfully.
F420	FB3 EnDat Communications Fault.	A communication error was detected with the EnDat 2.2 device connected to the X9 connector.
F421	SFD position sensor fault	Sensor or sensor wiring failure inside motor
F423	NV Failure, Multiturn Overflow.	The position saved in memory is corrupted.
F436	EnDat overheated.	EnDat feedback device is over temperature.
F438 n438	Following error (numeric)	Motor did not follow command values. Motor exceeded maximum allowed position following error (numeric).
F439 n439	Following error (user).	Motor did not follow command values. Motor exceeded maximum allowed position following error (user).
F450	Following error (presentation).	Motor did not follow command values. Motor exceeded maximum allowed position following error (presentation).
F451 n451	Tamagawa encoder: battery.	The external battery voltage is too low. F451 fault is generated if the AKD is not powered. The n451 warning is generated if the AKD is powered. This fault can be inhibited with FAULT451.ACTION.
F452	Multiturn overflow not supported with this feedback.	Non-multiturn feedback is connected while FB1.PMT-SAVEEN is active.
F453 to F459	Tamagawa encoder: communication.	Bad communication with the feedback device.
F460	Tamagawa encoder: over speed.	When the drive was powered off and the feedback was powered by the external battery, this fault is generated if the shaft is rotated above a maximum speed that can be maintained when battery powered.
F461	Tamagawa encoder: counting Error.	When the feedback is powered on the position (within on revolution) was incorrect because of a problem with the feedback device.

Fault	Message/Warning	Cause
F462	Tamagawa encoder: counting overflow.	Multi-turn counter has overflowed.
F463	Tamagawa encoder: overheat.	The temperature of the encoder substrate exceeds overheating detection temperature during main power-on.
F464	Tamagawa encoder: multiturn error.	Any bit-jump occurs in the multi-turn signal during main power-on.
F465	Excessive shock detected by feedback device.	Excessive shock from an impact or vibration has caused an error in the feedback device. Internal error in the feedback device mechanism, resulting in bad position data.
F467	Hiperface DSL fault.	Hiperface DSL feedback malfunction.
F468	FB2.SOURCE not set, Remote Commutation not possible.	Feedback Type 44 is being used, which requires FB2 to be setup with a working encoder input. If FB2 is not configured, then Feedback Type 44 cannot complete remote commutation from an external feedback input.
F469	FB1.ENCRESES is not power of two, Remote Commutation not possible.	Feedback Type 43 requires that the feedback resolution be a power of two. Feedback Type 43 is not supported for all feedback resolutions.
F473	Wake and Shake. Insufficient movement	There was less movement than defined by WS.DISTMIN.
F475	Wake and Shake. Excess movement.	WS.DISTMAX has been exceeded in WS.MODE 0. Or more than 360 degrees was traveled in WS.MODE 2.
F476	Wake and Shake. Fine-coarse delta too large.	The angle difference between the coarse and fine calculation was larger than 72 deg.
F478 n478	Wake and Shake. Overspeed.	WS.VTHRESH was exceeded.
F479	Wake and Shake. Loop angle delta too large.	The angle between complete loops was larger than 72 deg.
F480	Fieldbus command velocity too high.	Fieldbus command velocity exceeds VL.LIMITP.
F481	Fieldbus command velocity too low.	Fieldbus command velocity exceeds VL.LIMITN.
F482	Commutation not initialized.	The motor requires the commutation initialization (there are no encoder commutation tracks, Hall sensors, etc.) and no successful Wake and Shake sequence has been performed
F483	Motor U phase missing.	No current was detected in the motor's U phase during Wake and Shake initialization (Mode 0 only).
F484	Motor V phase missing.	No current was detected in the motor's V phase during Wake and Shake initialization (Mode 0 only).
F485	Motor W phase missing.	No current was detected in the motor's W phase during Wake and Shake initialization (Mode 0 only).
F486	Motor velocity exceeds EMU-speed.	Motor velocity exceeds the maximum speed the emulated encoder output can generate.
F487	Wake and Shake - Validating Positive Movement Failed.	After applying a positive current, motor moved in the wrong direction.
F489	Wake and Shake - Validating Negative Movement Failed.	After applying a negative current, motor moved in the wrong direction.

Fault	Message/Warning	Cause
F490	Wake and Shake - Validating Comm. angle timed out.	During one of the W&S validation stages, the drive stopped responding to commands.
F491	Wake and Shake - Validating Comm. angle moved too far - Bad Comm Angle.	After applying a current, the motor moved too far (>15 electrical degrees).
F492	Wake and Shake - Validating Comm. angle required more than MOTOR.ICONT.	A current larger than MOTOR.ICONT was used to excite the motor.
F493	Invalid commutation detected – motor accelerating in the wrong direction.	A commutation error occurred when current has another sign than acceleration and velocity over a defined time.
F501 n501	Bus over voltage.	Bus voltage too high. Usually, this problem is load related.
F502	Bus under voltage. Warning issued prior to fault.	Bus voltage below threshold value.
F503 n503	Bus capacitor overload.	Single phase AC input on a drive only rated for three-phase input or excessive single-phase power load.
F504 to F518	Internal supply voltage fault	Internal supply voltage fault detected
F519	Regen short circuit.	Regen resistor short circuit.
F521 n521	Regen over power.	Too much power stored in regen resistor.
F523	Bus over voltage FPGA	Bus over voltage hard fault.
F524 n524	Drive foldback.	Maximum drive power has been exceeded. The power has been limited to protect the drive.
F525	Output over current.	Current exceeds drive peak.
F526	Current sensor short circuit.	Current sensor short circuit.
F529	Iu current offset limit exceeded.	Hardware failure detected.
F530	Iv current offset limit exceeded.	Hardware failure detected.
F531	Power stage fault.	Hardware failure detected.
F532	Drive motor parameters setup incomplete.	Before a motor can be enabled, you must configure a minimum set of parameters. These parameters have not been configured.
F534	Failed to read motor parameters from feedback device.	Motor either does not have motor feedback memory, or the motor feedback memory is not programmed properly so the parameters cannot be read.
F535	Power-board over-temperature fail.	The power-board temperature sensor indicates more than 85 °C.
F536	Standby power supply fault.	text in process.
F537	Precharge fault.	text in process.
F560	Regen near capacity, could not prevent over voltage.	When a F501 Bus Over Voltage occurs, while the regen resistor is at or above 75% of its dissipation capacity.
n580	Using derivate of position when using sensorless feedback type in position mode.	text in process
n581	Zero velocity when using induction sensorless feedback type in position mode.	text in process

Fault	Message/Warning	Cause
n601	Modbus data rate is too high.	Modbus controller data rate is too high.
F602	Safe torque off.	Safe torque off function has been triggered.
n603	OPMODE incompatible with CMDSOURCE	This warning is generated when the drive is enabled and the gearing command source is selected at the same time as torque or velocity op-mode.
n604	EMUEMODE incompatible with DRV.HANDWHEELSRC.	Emulated encode mode is incompatible with the selected handwheel source.
F621	Control Board CRC fault.	Communications with the Power Board Failed
F623	Power Board CRC fault.	
F624	Power Board Watchdog fault.	
F625	Power Board Communication fault.	
F626	Power Board FPGA not configured.	
F627	Control Board Watchdog fault.	
F701	Fieldbus runtime.	
F702 n702	Fieldbus communication lost.	All fieldbus communication was lost.
F703	Emergency timeout occurred while axis should disable	Motor did not stop in the timeout defined.
n704	PVT buffer overflow	text in process.
n705	PVT buffer underflow	text in process.

9.4.2 Additional fault messages AKD-T

AKD BASIC runtime faults are displayed in the two-digits 7-segment display of the drive:

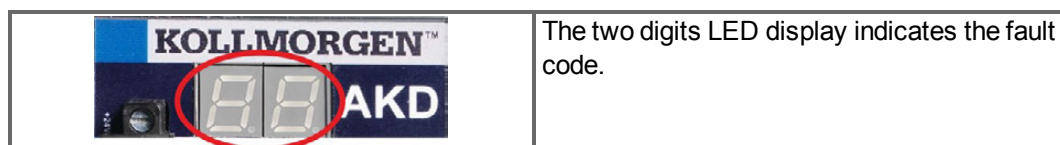

The two digits LED display indicates the fault code.

The additional runtime fault messages for AKD-T are coded with numbers starting from F801. All faults activate the fault relay and can be cleared with DRV.CLRFAULTS.

NOTE

More information about fault messages and clearing faults can be found in the WorkBench online help.

Remedy for all errors: Clear Fault, fix user program, recompile, download and attempt to run the program again.

Error	Description	Cause
F801	Divide by zero.	User Program attempted to divide by zero.
F802	Stack Overflow.	User Program contains an infinite recursion or incorrectly array.
F803	Insufficient Memory.	User program creates an excessive demand for memory.
F804	No interrupt handler defined.	User program is missing an interrupt service routine, but an interrupt is called.
F805	Interrupt error.	User program contains an error in an interrupt routine.
F806	Max string length exceeded.	User program attempted to use a string exceeding 255 characters.
F807	String overflow.	User program has a exception causing excessive string usage.
F808	Array out of bounds.	User program exception caused an array to exceed its bounds.
F809	Feature not supported.	User program contains a feature that the current firmware version does not support.
F810	Internal firmware/hardware error.	User program attempted to perform an action that causes a firmware or hardware error.
F812	Parameter not supported.	User program calls a parameter that is not supported by the firmware.
F813	Parameter access error.	User program contains a parameter access error.
F814	Data not found.	User program attempted writing an invalid recorder parameter.
F815	Data invalid.	User program attempted executing an invalid command.
F816	Data too high.	User program contains a parameter that is above the accepted range.
F817	Data too low.	User program contains a parameter that is below the accepted range.
F818	Param type out of range.	User program attempted to write a value which was out of a range.
F819	Data not divisible by 2.	User program executed a function that requires it to be divisible by two.
F820	Invalid position modulo setting.	User program contains an incorrectly configured modulo setting.
F821	Cannot read from command.	User program attempted to perform a read of parameter that is a command or statement.
F823	Enable Drive first.	User program is attempting to execute motion that requires the drive to be enabled.
F824	DRV.OPMODE must be 2 (position).	User program is attempting to execute motion that requires the drive to be in program mode.

Error	Description	Cause
F825	DRV.CMDSOURCE must be 5 (program).	User program is attempting to execute motion that requires the drive to be in position mode.
F826	Cannot execute during a move.	User program is attempting an invalid execution during a move.
F827	Writing to read-only parameter.	User program attempted writing to a read-only parameter.
F828	Disable Drive first.	User program tries to execute a function that requires a disabled drive.
F829	Opcode not supported - upgrade firmware.	User program contains unsupported Opcode.
F830	No negative values allowed.	User program uses illegal negative value.
F831	BASIC program is invalid. May need firmware upgrade.	User program contains invalid c
F832	BASIC program is missing.	User program is missing.
F901	Too many cams.	User program contains too many cams.

9.4.3 Additional error and alarm messages AKD-M

Faults/Errors and Warnings/Alerts are displayed in the 7 segment displays of the drive:

AKD two digits	AKD-M two + one digits
	
<p>The two digits LED display indicates the AKD messages. AKD fault messages are coded with "F", warnings are coded with "n" and are described in "Fault and Warning Messages" (→ p. 180)</p>	<p>The one digit LED indicates the PDMM messages of the AKD PDMM. Error messages are coded with "E", alarms are coded with "A" and are described in the chapter below.</p>

To simplify handling, the error and alarm handling process is consistent, so you can always apply the same recovery steps. When an error or alarm occurs, it is displayed to the one digit display, you can identify the error in the table below and follow the recommendations to fix the problem, clear the display, and resume machine operation.

Active errors and alarms can be cleared with the controller command **ClearCtrlErrors**, (Note: non-clearable errors will remain).

9.4.3.1 Errors

When an Error or Alarm occurs, always check the controller log messages. The log messages will provide more details about the failure and the history of events leading up to the failure. From the log messages, you can determine the specifics about the cause of the failure to correct the underlying problem.

NOTE

More information about fault messages, remedy and clearing faults can be found in the Work-Bench online help.

Error	Description	Cause	Remedy
E01	Critical temperature exceeded. PDMM operation is stopped, CPU will be put to sleep.	CPU temperature exceeded safe operating temperature limit.	Power-off. Check airflow and operating environment are within hardware specifications. Allow unit to cool before power-on.
E02	Out of memory. KAS runtime is stopping.	Memory leak, memory corrupted, or hardware memory failure.	Power-off/on. If problem is recurrent, check release notes for firmware updates or return hardware for repair.
E03	Fan failure.	CPU cooling fan was not able to operate properly.	Check temperature and monitor for High temp alarm (see A01). Return hardware for fan replacement.
E10	Firmware is corrupted.	Flash memory corrupted during firmware download or flash hardware failure.	Re-download firmware or boot into recovery mode, download. If the problem is recurrent, power-off/on. Check release notes for firmware updates. firmware, and power-off/on. If problem persists, return hardware for repair.
E11	Flash is corrupted, no filesystem is available.	At startup the filesystem could not be mounted on the flash.	Reset to factory defaults. If problem persists, return hardware for repair.

Error	Description	Cause	Remedy
E12	Not enough flash memory available.	Flash memory is full, unable to write to flash.	Clean-up the flash memory by removing log files, application programs, recipes, or other data files.
E13	Out of NVRAM space for retained variables.	NVRAM is full.	Change application to reduce the amount of retained variables.
E14	Reset to Factory Defaults failed.	Flash memory could not be formatted during a Reset to Factory Defaults procedure.	Try reset to factory defaults again from power-on. If problem persists, return hardware for repair.
E15	Cannot read/write files from/to a SD card.	SD card is not plugged-in or the filesystem is corrupt and cannot be mounted.	Insert a valid SD card or re-format the SD card using Settings->SD card->Format button.
E16	Not enough space available on the SD card.	SD card is full, unable to write to the SD card.	Clean-up SD card space by deleting files or re-format the card using Settings->SD card->Format button.
E20	Runtime plug-in, process, thread or application failed to start.	KAS runtime or application code failed to auto-start at boot.	Power-off/on. Reset to factory defaults. If problem is recurrent, check release notes for firmware updates or download firmware.
E21	Runtime plug-in, process, or thread failed to respond during operation.	KAS runtime code failed during normal operation.	Power-off/on. If problem is recurrent, check release notes for firmware updates.
E22	Fatal error in PLC program, application stopped.	Virtual machine failed to execute an instruction.	Re-compile application, download, and re-start.
E23	CPU is overloaded.	Either the motion engine cycle did not complete or the PLC program did not complete within the timeout period due to excessive CPU loading.	Stop the application or power-off/on. Reduce the sample rate, simplify the application, or reduce the application cycles and re-start the application.
E24	PLC application cannot be started	<ol style="list-style-type: none"> 1. Maintenance operation is in progress. 2. Controller is in online config mode. 3. AKD Restore failed. 4. The IDE version of the compiled PLC code and controller runtime version do not match. 	<ol style="list-style-type: none"> 1. Check controller web-server home page for any maintenance operation in-progress. Wait for the operation to finish. 2. Connect to the controller with the IDE and disable online config mode. 3. Check EtherCAT network topology by using the Scan network button in the web-server's Restore tab. Correct the physical topology and re-execute an AKDrestore. 4. IDE version (only major.minor.micro) should match with runtime version. To correct, install the correct version of IDE or Runtime.
E30	EtherCAT communication failure during operational mode.	EtherCAT network operation failed due to a network communication error.	Check the EtherCAT network wiring and devices state. Re-start the application.
E31	EtherCAT communication failure during preop mode.	EtherCAT network operation failed due to a network communication error.	Check the EtherCAT network wiring and devices state. Re-start the application.

Error	Description	Cause	Remedy
E32	EtherCAT communication failure during bootstrap mode.	EtherCAT network operation failed due to a network communication error.	Check the EtherCAT network wiring and devices state. Re-start the application.
E33	EtherCAT failed to initialize into operational mode.	EtherCAT network initialization failed due to a network initialization or communication error.	Check the EtherCAT network wiring and devices state. Re-start the application.
E34	EtherCAT failed to initialize into preop mode.	EtherCAT network initialization failed due to a network communication error.	Check the EtherCAT network wiring and devices state. Re-start the application.
E35	EtherCAT failed to initialize into bootstrap mode.	EtherCAT network initialization failed due to a network communication error.	Check the EtherCAT network wiring and devices state. Re-start the application.
E36	EtherCAT failed to discover the expected devices.	EtherCAT network discovery failed due to a mismatch between the discovered and expected devices.	Check the EtherCAT devices and wiring order. Correct the device order wiring or re-scan the network, re-compile, and download the updated application. Re-start the application.
E37	EtherCAT failed to return to init state.	EtherCAT network initialization failed due to a network communication error.	Check the EtherCAT network wiring and devices state. Re-start the application.
E50	Backup to SD card failed.	An unrecoverable error occurred during the backup operation.	Repeat the backup to SD card operation. If it fails again, replace the SD card.
E51	Restore from SD card failed..	An unrecoverable error occurred during the restore operation.	Do NOT reboot the PDMM! Repeat the restore operation. If it fails again, reset the PDMM to factory defaults. If problem persists, return hardware for repair.
E52	SD Backup files are missing or corrupt.	The restore operation failed due to missing, incomplete, or corrupt files on the SD card.	Perform a backup operation before the restore or use an SD card with valid backup files.
E53	AKD restore operation failed.	The restore operation failed due to improper or incomplete AKD configuration.	Check EtherCAT network topology by using the Scan network button in the web-server's Restore tab. Correct the physical topology and re-execute an AKD restore.

9.4.3.2 Alarms

Alarm	Description	Cause	Remedy
A01	High temperature exceeded	CPU temperature near the safe operating temperature limit.	Check airflow and operating environment are within hardware specifications.
A02	Low on memory.	Memory leak or corruption.	Power-off/on. If problem is recurrent, check release notes for firmware updates or return hardware for repair.
A04	Low input voltage	+24 volt input power is +19 volts or less.	Check power supply voltage and connection to the PDMM.
A12	Flash memory is low on free space.	Flash memory is almost full.	Clean-up the flash memory by removing log files, application programs, recipes, or other data files. Reset to factory defaults.

Alarm	Description	Cause	Remedy
A21	Recoverable process or thread failed to respond during operation.	KAS non-runtime code failed during normal operation and was automatically restarted.	If problem is recurrent, power-off/on. Check release notes for firmware updates.
A23	CPU is overloaded		Reduce the sample rate, simplify the application, or reduce the application cycles.
A30	EtherCAT missed a send frame during operation mode.	EtherCAT master was unable to send a frame for one or more cycles.	Reduce the controller CPU load.
A38	EtherCAT missed a receive frame during operation mode.	EtherCAT master did not receive a frame for one or more cycles.	Check the EtherCAT network wiring and devices.
A40	Local digital IO missed a cyclic update	Local digital IO was not updated during a cycle or the updates are no longer synchronous.	Reduce the sample rate, simplify the application, or reduce the application cycles.

9.5 Troubleshooting the AKD

Drive problems occur for a variety of reasons, depending on the conditions in your installation. The causes of faults in multi-axis systems can be especially complex. If you cannot resolve a fault or other issue using the troubleshooting guidance presented below, customer support can give you further assistance.

NOTE

More details on the removal of faults can be found in the WorkBench online help.

Problem	Possible Causes	Remedy
HMI message: Communication fault	<ul style="list-style-type: none"> wrong cable used, cable plugged into wrong position on drive or PC wrong PC interface selected 	<ul style="list-style-type: none"> plug cable into the correct sockets on the drive and PC select correct interface
Drive does not enable	<ul style="list-style-type: none"> HW Enable not wired HW or SW Enable not set 	<ul style="list-style-type: none"> connect HW Enable (X8 pin 4) Apply 24V to HW Enable and select SW Enable in WorkBench / Fieldbus
Motor does not rotate	<ul style="list-style-type: none"> drive not enabled software enable not set break in setpoint cable motor phases swapped brake not released drive is mechanically blocked motor pole no. set incorrectly feedback set up incorrectly 	<ul style="list-style-type: none"> apply ENABLE signal set software enable check setpoint cable correct motor phase sequence check brake control check mechanism set motor pole no. set up feedback correctly
Motor oscillates	<ul style="list-style-type: none"> gain is too high (speed controller) feedback cable shielding broken AGND not wired up 	<ul style="list-style-type: none"> reduce VL.KP (speed controller) replace feedback cable join AGND to CNC-GND
Drive reports following error	<ul style="list-style-type: none"> I_{rms} or I_{peak} set too low current or velocity limits apply accel/decel ramp is too long 	<ul style="list-style-type: none"> verify motor/drive sizing verify that IL.LIMITN/P, VL.LIMITN/P are not limiting the drive reduce DRV.ACC/DRV.DEC
Motor overheating	<ul style="list-style-type: none"> motor operating above its rating motor current settings incorrect 	<ul style="list-style-type: none"> verify motor/drive sizing verify motor continuous and peak current values are set correctly
Drive too soft	<ul style="list-style-type: none"> K_p (speed controller) too low K_i (speed controller) too low filters set too high 	<ul style="list-style-type: none"> increase VL.KP (speed controller) increase VL.KI (speed controller) refer to documentation regarding reducing filtering (VL.AR*)
Drive runs roughly	<ul style="list-style-type: none"> K_p (speed controller) too high K_i (speed controller) too high filters set too low 	<ul style="list-style-type: none"> reduce VL.KP (speed controller) reduce VL.KI (speed controller) refer to documentation regarding increasing filtering (VL.AR*)
During installation, the message "Please wait while the installer finishes determining your disk space requirements" appears and never disappears.	<ul style="list-style-type: none"> MSI installer issue. Harddisk space not sufficient 	<ul style="list-style-type: none"> Cancel the installation. Relaunch the installer (you may need to try several times, the problem is random). Make sure that you have enough disk space on your hard disk (~500MB to allow Windows .NET update if necessary), if not make some space.

10 Record of document revisions

Revision	Remarks
-, 11/2009	Beta launch version
-, 12/2009	Digital I/O corrections, several updates
A, 03/2010	CAN termination connector "optional", data dynamic brake updated, resolver signals renamed, CE certificate, X9 description updated, technical data completed
B, 06/2010	Several updates, typos, dimensions corrected, switch on/off timing diagrams
C, 07/2010	Switch on/off timing diagrams, typos, cover layout
D, 01/2011	Hardware Revision C, STO certified, voltage level digital inputs changed
E, 04/2011	Analog In/Out specification extended, single-/two phase mains supply updated
F, 10/2011	PROFINET RT, Modbus TCP, several updates, cover layout updated
G, 03/2012	AKD PDMM added, 270 VAC mains supply restriction removed, part number scheme extended, EnDat 2.2 @ X9, STOP chapter updated, dimension drawings
H, 05/2012	AKD-T-IC added, I/O option card signals added, PDMM error codes updated
J, 08/2012	Smart Abs (Tamagawa) new, BiSS C new, X21 & X22 pinout updated
K, 11/2012	Feedback wiring diagrams updated, font size hint, fault tables updated, regen fusing
L, 05/2013	Hiperface DSL Feedback new (from FW 1.9), fault tables updated, KCM module added
M, 09/2013	24A AKD-M added, fault tables update, outer dimensions updated
N, 12/2013	sercos [®] III option added, SFD3 feedback added, sincos frequency limit, automatic restart notes

This page intentionally left blank.

11 Index

A

Abbreviations	12
AKD Family	30
Ambient temperature	32
Analog inputs	129
Analog setpoints	129
Aux. supply 24V, interface	91

B

BISS encoder	109
--------------------	-----

C

Cabinet Assembly	
Extended Width	65
Standard Width	61
Cable and Wire Requirements	39
CANbus	
Baud rate	155
Cable	156
CANopen interface	153
Node address	156
Termination	156
Capacitor Modules	96
CE conformance	22
Comcoder interface	115
Connection Diagrams	
B, P, T Variants	77
M variants	82
Connection Overview	
B, P, T Variants	75
M Variants	80
Connector Assignments	
B, P, T Variants	75
M Variants	80
Connectors	38

D

DC Bus Capacitance	41
DC bus link, interface	94
Dig. Encoder emulation, interface	123
Digital inputs	
all Variants	131
I/O option	136
M Variant	140
Dimensions	
Extended Width	67
Standard Width	63
Disposal	19
Document Revisions	195

DSL	108
Dynamic Braking	40

E

EC Declaration of Conformity	24
Emergency Off	50
Emergency Stop Function	50
Emulated Encoder Connector	117
Emulated Encoder Output	123
ENABLE	133
Enclosure protection	32
EnDat 2.1 encoder interface	111
EnDat 2.2 encoder interface	112
EtherCAT	159
EtherNet	
EtherCAT Protocol	159
Ethernet/IP Protocol	160
Modbus TCP Protocol	153
PROFINET RT Protocol	160
sercos® III Protocol	161
SynqNet Protocol	160
Ethernet/IP	160

F

Fault messages	180
FAULT relay	135
Feedback	103
Feedback Connection	104
Fusing	37

G

Grounding	71
Grounding Plates	88

H

Hardware requirements	
KAS IDE	171
WorkBench	165
Hiperface DSL	108
Hiperface encoder interface	113
Humidity	
in operation	32
Storage	18
Transport	18

I

I/O-Connection	125
Initial Drive Test	
B,P,T Variants	167
M Variants	173
Inputs	
Analog	129

Basic Data	33
Digital all Variants	131
Digital M Variant	140
Digital, I/O option	136
Enable	133
Programmable	133, 136
STO	52
Installation	
Electrical	69
Mechanical	60
Software KAS IDE	172
Software WorkBench	166
IP Address	
B, P, T Variants	150
M Variant	152
K	
KAS IDE	170
KCM	96
L	
Leakage current	58
M	
Mains supply, interface	92
Maintenance	19
Master-Slave	124
Modbus	153
Motor-holding brake	102
Motor interface	100
Motor Power Connection	101
Mounting position	32
N	
Nameplate	27
Noise Emission	32
O	
Operating systems	
KAS IDE	171
WorkBench	165
Outputs	
Analog	130
Basic Data	33
Digital all Variants	134
Digital M Variant	142
Digital, I/O option	138
Fault Relay	135
Relay, I/O option	139
P	
Package supplied	27
Packaging	18
Part number scheme	28
PC connection	149
Pollution level	32
PROFINET	160
Prohibited Use	
General	17
STO	52
Pulse Direction, interface	121
Pushbuttons	145
R	
Re-forming	163
Regen circuit	40
Regen resistor, interface	95
Relay Output, I/O option	139
Repair	19
Resolver interface	105
ROD 5V with Hall interface	115
S	
Safe Torque Off (STO)	52
Safety	14
Safety Instructions	
STO	53
sercos® III	161
Service Interface	149
Setup	163
B, P, T variants	164
M variants	170
Setup Software	
KAS IDE	170
WorkBench	164
SFD	106
SFD3	107
Shield connection	86
Shielding	71
Shock-hazard protection	58
SinCos encoder with Hall	114
Site	60
Site altitude	32
Stacking height	18
Stacking Height, Storage	18
Standards	23
Standards used	13
STO	52
Stop Function	50
Storage	18
Supply networks	89
Switch-on/switch-off behavior	43
Symbols used	11
SynqNet	160
System components, overview	73

T

Temperature	
in operation	32
Storage	18
Transport	18
Tightening torques, connectors	36
Transport	18
Trouble Shooting	194

U

UL Markings	21
Uninstalling	19
Up/Down Input	122
Use as directed	
Drive	17
KAS IDE Setup Software	170
STO	52
WorkBench Setup Software	164

V

Ventilation	
Ambient Conditions	32
Mechanical Installation	60
Vibrations	32

W

Warnings	180
Wiring	72

About KOLLMORGEN

Kollmorgen is a leading provider of motion systems and components for machine builders. Through world-class knowledge in motion, industry-leading quality and deep expertise in linking and integrating standard and custom products, Kollmorgen delivers breakthrough solutions that are unmatched in performance, reliability and ease-of-use, giving machine builders an irrefutable marketplace advantage.

For assistance with your application needs, visit www.kollmorgen.com or contact us at:

North America

KOLLMORGEN

203A West Rock Road
Radford, VA 24141 USA

Web: www.kollmorgen.com

Mail: support@kollmorgen.com

Tel.: +1 - 540 - 633 - 3545

Fax: +1 - 540 - 639 - 4162

Europe

KOLLMORGEN Europe GmbH

Pempelfurtstraße 1
40880 Ratingen, Germany

Web: www.kollmorgen.com

Mail: technik@kollmorgen.com

Tel.: +49 - 2102 - 9394 - 0

Fax: +49 - 2102 - 9394 - 3155

Asia

KOLLMORGEN

Rm 2205, Scitech Tower, China
22 Jianguomen Wai Street

Web: www.kollmorgen.com

Mail: sales.asia@kollmorgen.com

Tel.: +86 - 400 666 1802

Fax: +86 - 10 6515 0263

KOLLMORGEN[®]

Because Motion Matters™