

# POWERMAX II® M and P Series Stepper Motor

## Selection Guide

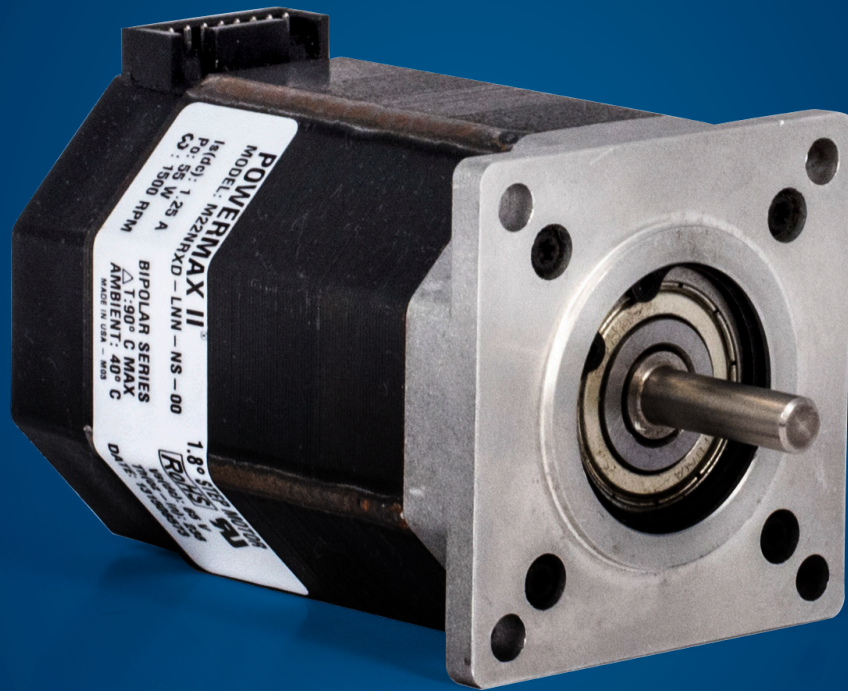

**KOLLMORGEN**

A REGAL REYNORD BRAND

# Kollmorgen: Your Partner, In Motion.

Every solution comes from a real understanding of the challenges facing machine designers and users.

Innovators consistently rate Kollmorgen as one of their best motion systems manufacturing partners. Whether you are looking for classic servo motors, direct-drive servo motors, stepper motors, drives & amplifiers, gearing, actuation, or multi-axis motion controllers, Kollmorgen is one of the few companies in the world that actually designs and manufactures all of these products.

Our customers are leaders in many industries such as Aerospace & Defense, Printing, Packaging & Converting, Food & Beverage Processing, Medical Imaging, In Vitro Diagnostics & Laboratory Automation, Pharmaceutical Manufacturing, Material Forming and Cutting, Oil & Gas, and Robotics. Kollmorgen is also a leader in Warehouse Automation, including complete AGV systems, software, awareness and autonomy.

Our Automation Solutions can be found on Mars and in space, ships and submarines, O&G drilling and metrology, surgical robots and laser eye surgery, even inside artificial hearts. These are just a few applications that demand high-performance and high-quality while satisfying their specific needs.

Because motion matters, it's our focus: Motion can distinctly differentiate a specific machine and deliver a marketplace advantage by increasing its performance and dramatically improving Overall Equipment Effectiveness (OEE).

High-performance motion can make your customer's machine more reliable and energy-efficient, enhance accuracy and improve operator safety. Motion also represents endless possibilities for innovation.

We've always understood this potential, and thus have kept motion at our core and in our Vision, Mission & Values, relentlessly developing products that offer precise control of torque, velocity and position accuracy in machines that rely on complex motion.

### How To Use This Selection Guide:

This guide covers the technical information required to select and order M2 / P2 Series stepper motors. Select the proper motor using one of the following procedures:

- » If you're already familiar with these motors and the available options, refer to the Model Nomenclature on pg. 8 to verify the part number and corresponding motor options prior to order.
- » If you're not familiar with M2 / P2 motors and available options: first refer to the General Specifications, pg. 5. To further evaluate individual winding specifications refer to the Drawings and Performance Data. After all the technical parameters and options are determined, construct a part number using the Model Nomenclature (pg. 8).

### Where To Order:

Kollmorgen utilizes an experienced channel of Authorized High-Tech Distributors (AHTDs) to assist our customers with applications, sizing and selection, ordering, and technical support. Visit our Distributor Locator to find locally available distributors. [www.kollmorgen.com/enus/where-to-buy/](http://www.kollmorgen.com/enus/where-to-buy/)

Kollmorgen Customer Service Representatives are also available by phone or e-mail and can assist in selecting and contacting local distributors.

- » North America: 1-540-633-3545, [support@kollmorgen.com](mailto:support@kollmorgen.com)
- » Europe/Middle East/Africa: +49 (0) 2102 9394 0, [think@kollmorgen.com](mailto:think@kollmorgen.com)
- » Asia: +86-400 661 2802, [sales.china@kollmorgen.com](mailto:sales.china@kollmorgen.com)

# Table of Contents

► <b>M2 / P2 Series Stepper Motors</b>	<b>4</b>
General Specifications	5
M2 / P2 Motor Connection Information	6
M/P Optional Leaded Mating Connectors	7
M2 / P2 Motor Nomenclature	8
M2 / P2 Motor Dimensional Drawings	9
M2 / P2 Motor Performance Data	10
M2 / P2 Motor Performance Curves	14
M2 / P2 Encoder Options	17

### Trademarks

AKD is a registered trademark of Kollmorgen Corporation  
 AKM is a registered trademark of Kollmorgen Corporation  
 Cartridge DDR is a registered trademark of Kollmorgen Corporation  
 EnDat is a registered trademark of Dr. Johannes Heidenhain GmbH  
 EtherCAT is a registered trademark and patented technology, licensed by Beckhoff Automation GmbH  
 Ethernet/IP is a registered trademark of ODVA, Inc.  
 Ethernet/IP Communication Stack: copyright (c) 2009, Rockwell Automation  
 sercos® is a registered trademark of sercos® international e.V.  
 HIPERFACE and HIPERFACE DSL are registered trademarks of Max Stegmann GmbH  
 PROFIBUS is a registered trademark of PROFIBUS and PROFIBUS International (PI)  
 SIMATIC is a registered trademark of SIEMENS AG  
 SpeedTec, ytec, itec and htec are registered trademarks of TE Connectivity Ltd.  
 Windows is a registered trademark of Microsoft Corporation

# ▶ POWERMAX II® M and P Series

Ideally suited for lower loads, the POWERMAX II® M and P Series is designed to provide exceptional value, versatility and ease of use. Among the most powerful stepper motors available, they deliver high torque in a compact package and are available in a wide range of frame sizes, constructions, and optional modifications. POWERMAX II has an extremely competitive market lead time and is backed by UL and CE certifications.

## Features

- » P2 models: NEMA 23 (60 mm) motors available in 3 stack lengths with torque ratings from 0.30 to 1.51 N-m (42 to 214 oz-in) nominal holding torque
- » M2 models: NEMA 23 (60 mm) motors available in 2 stack lengths with torque ratings from 0.67 to 1.79 N-m (95 to 253 oz-in) nominal holding torque
- » Available with affordable co-engineered modifications to suit your application needs, time frame and budget
- » Numerous standard modifications and customer-specified options
- » Speeds up to 3,000 rpm meet the velocity demands of most high-torque applications
- » Oversized 30 mm bearings increase bearing and motor life
- » Complete subassemblies available
- » UL, CE, RoHS and REACH certifications

## Benefits

- » Broad product line with flexible modifications and rapid prototyping for exceptional design flexibility
- » Quality construction for reliability and long service life
- » Designed for quick, easy integration into new and existing applications
- » Global supply footprint with localized support
- » Competitive pricing and lead times



## General Specifications

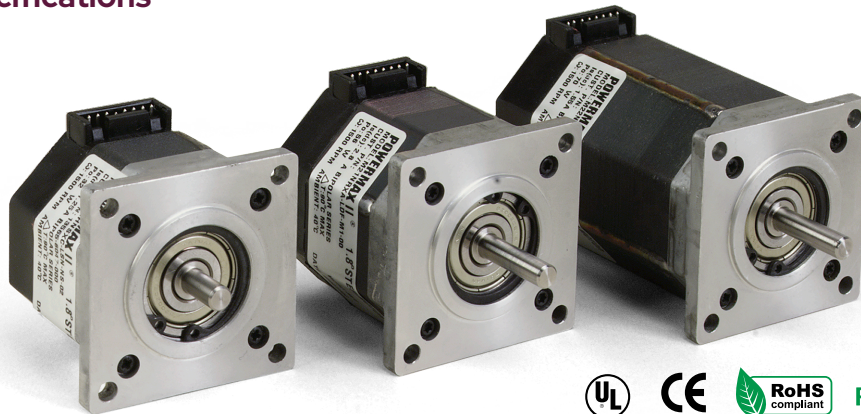

- » NEMA Size 23
- » Standard (P) and enhanced (M) using SIGMAX technology
- » Standard laminated and low inertia “J” rotors for maximum acceleration
- » Standard NEMA mounting
- » Oversized 30 mm bearings
- » UL, CE, RoHS, REACH Compliant
- » Unipolar or Bipolar windings
- » Standard Features: Shaft Flats or Keyways, Rear Shaft, Flying Leads or Motor-Mounted Connectors, Encoder Mounting Provisions, Incremental Encoders
- » Co-Engineered Options: Shaft Modifications, Special Windings, Lead Lengths, Connectors

Parameter	M / P
NEMA frame size	23
Windings	Unipolar and Bipolar
Full Steps per Revolution	200
Step Angle (degrees)	1.8
Step Accuracy % (of one full step, no load)	± 1.5% M / ± 3% P
Operating Temperature	-20° C to +40° C
Insulation Class	Class B, 130° C
Insulation Voltage (Vdc)	340
Insulation Resistance	100 Megohms

### Rotor Inertia Characteristics

Single and double stack motors are available with both standard and low inertia “J” rotors. Choose low inertia to produce the highest acceleration rates possible. Low inertia motors are most effective for operation below 2,000 RPM. Choose standard to generate maximum torque.



Low Inertia Rotor

Standard Rotor

# M2 / P2 Series Stepper Motors

## M2 / P2 Series Stepper Motor F, H, and L Connection Information

### Integrated "X" Connector Option

"X"	Part Number
8 Lead	GW0000F
6 Lead	GW0000E
4 Lead Parallel	GW0000H
4 Lead Series	GW0000L

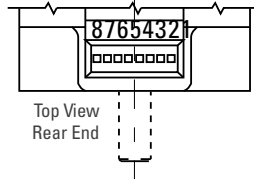

### Typical Leaded Connector

4-lead shown

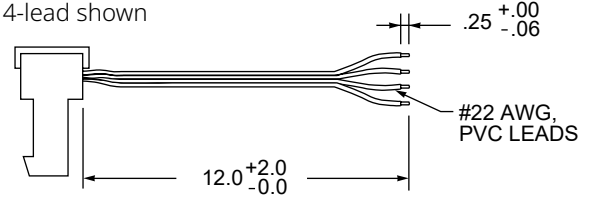

### Optional Mating Connector Only

A separate mating connector or housing and strain relief cover are available from Kollmorgen or AMP. The user attaches leads to the connector.

Item	Kollmorgen	AMP
Standard Housing	GP00012	3-641653-8
Standard Cover	GP00013	643077-8

### F (GW0000F) 8-Lead Configuration

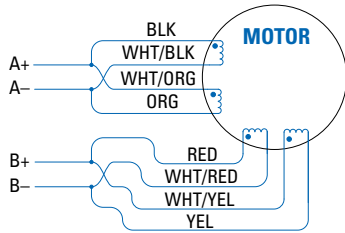

### 4-Lead Bipolar Connection Parallel

Driver Connection	Lead Color	Pin No.
A	Black & Wht/Org	6 & 5
$\bar{A}$	Org & Wht/Blk	1 & 2
B	Red & Wht/Yel	8 & 7
$\bar{B}$	Yel & Wht/Red	3 & 4

### Bipolar Full Step Phase Sequence

STEP	A	$\bar{A}$	B	$\bar{B}$
1	+	-	-	+
2	-	+	-	+
3	-	+	+	-
4	+	-	+	-
1	+	-	-	+

CCW ↓      ↑ CW

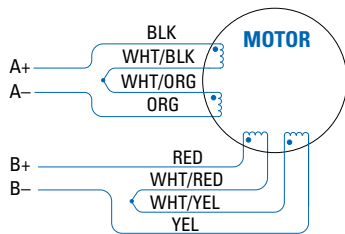

### 4-Lead Bipolar Connection Series

Driver Connection	Lead Color	Pin No.
A	Black (Blk)	6
$\bar{A}$	Orange (Org)	1
B	Red	8
$\bar{B}$	Yellow (Yel)	3
None	Wht/Blk & Wht/Org	2 & 5
None	Wht/Red & Wht/Yel	4 & 7

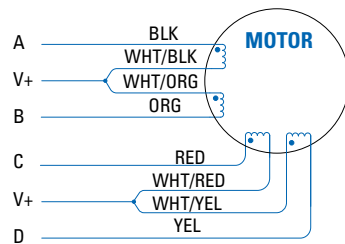

### 6-Lead Unipolar Connection

Driver Connection	Lead Color	Pin No.
A	Black (Blk)	6
B	Orange (Org)	1
C	Red	8
D	Yellow (Yel)	3
V+	Wht/Blk & Wht/Org	2 & 5
V+	Wht/Red & Wht/Yel	4 & 7

### Unipolar Full Step Phase Sequence

STEP	A	B	C	D
1	GND	0	GND	0
2	0	GND	GND	0
3	0	GND	0	GND
4	GND	0	0	GND
1	GND	0	GND	0

CCW ↓      ↑ CW

# M/P Leaded Mating Connectors for "X" Integrated Connector Option

## E (GW0000E) 6-Lead Configuration

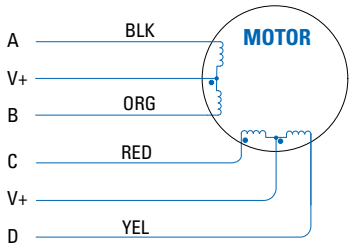

### 6-Lead Unipolar Connection

Driver Connection	Lead Color	Pin No.
A	Black (Blk)	6
B	Orange (Org)	1
C	Red	8
D	Yellow (Yel)	3
V+	Wht/Blk/Org	2 & 5
V+	Wht/Red/Yel	4 & 7

### Unipolar Full Step Phase Sequence

STEP	A	B	C	D
1	GND	0	GND	0
2	0	GND	GND	0
3	0	GND	0	GND
4	GND	0	0	GND
1	GND	0	GND	0

CCW ↓ ↑ CW

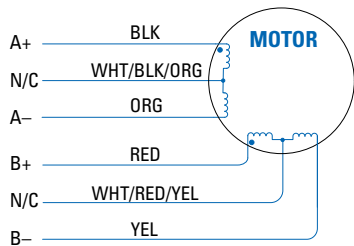

### 4-Lead Bipolar Series Connection

Driver Connection	Lead Color	Terminal Number
A	Black	6
$\bar{A}$	Orange	1
B	Red	8
$\bar{B}$	Yellow	3
N/C	Wht/Blk/Org	2 & 5
N/C	Wht/Red/Yel	4 & 7
Ground	Green/Yellow	n/a

### Bipolar Full Step Phase Sequence

STEP	A	$\bar{A}$	B	$\bar{B}$
1	+	-	-	+
2	-	+	-	+
3	-	+	+	-
4	+	-	+	-
1	+	-	-	+

CCW ↓ ↑ CW

## H (GW0000H) and L (GW0000L) 4-Lead Configuration

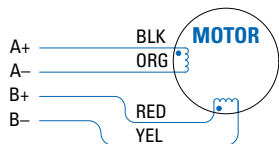

### 4-Lead Bipolar Connection

Driver Connection	Lead Color	Pin No. Series GW0000L	Pin No. Parallel GW0000H
A	Black	6	6 & 5
$\bar{A}$	Orange	1	1 & 2
B	Red	8	8 & 7
$\bar{B}$	Yellow	3	3 & 4
Ground	Green/Yellow	n/a	n/a

### Optional Ground Wire

#### NOTES:

- ⚠️ GROUND LABEL PLACED IN FRONT OF GROUND SCREW.
- ⚠️ GREEN/YELLOW SAFETY EARTH CONDUCTOR (18AWG).

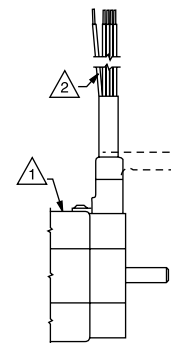

# M2 / P2 Series Stepper Motors

## M2 / P2 Series Stepper Motor Nomenclature

P 2 1 N R X A - L N N - NS - 00

### Series

- P Standard
- M Enhanced (n/a half stack)

### Frame Size

- 2 NEMA 23 (2.25 in. across flat)

### Number of Stacks

- H Half stack
- 1 1 stack
- 2 2 stacks

### Mounting

- N NEMA
- S Special, contact customer support

### Construction

- R Regular
- S Special, contact customer support

### Connections

- E 6 flying leads
  - F 8 flying leads
  - H 4 flying leads, parallel connection
  - L 4 flying leads, series connection
  - X Receptacle
  - S Special, contact customer support
- For X (receptacle) designation, Mating leaded connectors may be ordered separately. Optional GRN/YEL ground wire available.

### Winding Type

- A, B, C, D
- S Special, contact customer support

### Sequence Number

Insert 00 if all parts are standard  
Other numbers will be assigned for special motors.

### Encoder Option

NS No feedback  
To use encoders below, you must specify shaft configuration D (double ended)

**Caution:** An encoder with line driver output may be required for use with some stepper motor controls.

- M1 Encoder mounting provisions
- HD Encoder 500 LPR
- HJ Encoder 512 LPR
- SS Special, contact customer support

### Shaft Modifications

- N Smooth
- F Flat
- S Special, contact customer support

### Shaft Configuration (Diameter & Length)

- N Single (no rear shaft extension)
- D Double (rear shaft extension)
- S Special, contact customer support

### Rotor Type

- L Standard
- J Low inertia (n/a half stack)



## M2 / P2 Series Outline Drawings

### M2 / P2 Regular Construction Hookup

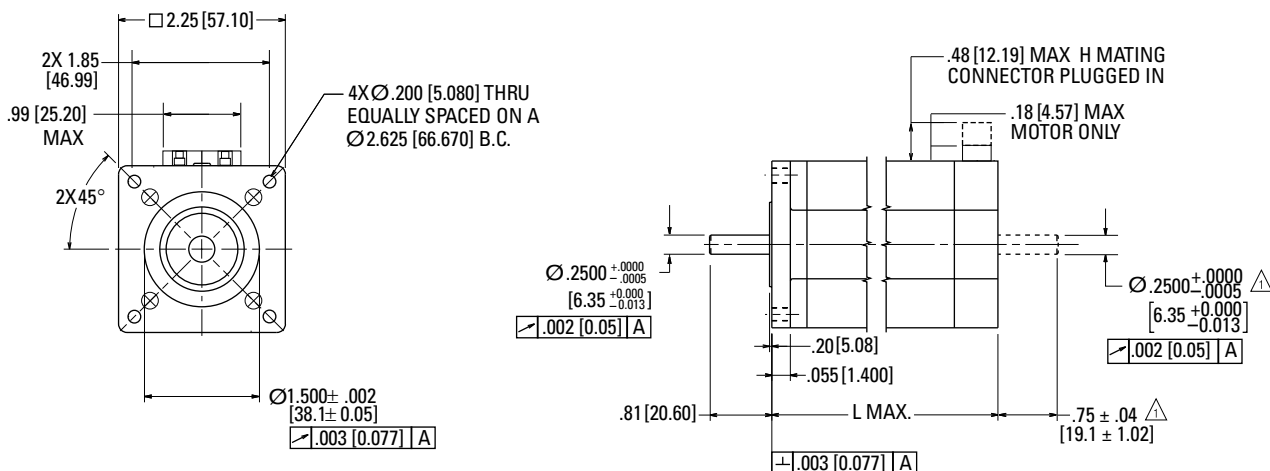

### Integrated "X" Connector Option

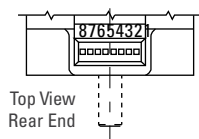

△ Rear shaft extension "D" available as shown. Same diameter as front shaft extension.

Motor Model	L Max.
P2H	1.60 [40.7]
P or M21	2.06 [52.3]
P or M22	3.10 [78.7]

### Standard Shaft Options

1. Shaft modifications also available.
2. Flat shaft "F" available on front shaft as shown.

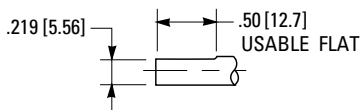

### Encoder Option

See page 15 for more details

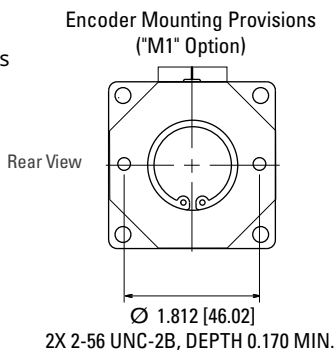

Dimensions in inches [mm]

# M2 / P2 Series Stepper Motors

## P2 Short Stack/ 1 Stack Performance Data

	Motor Model Number	Config.			Holding Torque (2 phases on) oz-in (Nm) +/-10%	Rated Current/Phase Amps DC	Phase Resistance Ohms +/-10%	Phase Inductance mH Typical	Thermal Resistance Mounted °C/Watt	Rotor Inertia oz-in-s <sup>2</sup> (kg-m <sup>2</sup> x 10 <sup>-3</sup> )	Weight lb (kg)	Shaft Loading*	
		Parallel	Series	Unipolar								Radial Force lb (N)	Axial Force lb (N)
Short Stack	P2HxxHH-L	•			59 (0.42)	5.2	0.22	0.50	6.6	0.0010 (0.0071)	1.0 (0.45)	20 (89)	13 (58)
	P2HxxLH-L		•			2.6	0.90						
	P2HxxHB-L	•			59 (0.42)	2.6	0.76	1.9					
	P2HxxLB-L		•			1.3	3.04	7.6					
	P2HxxHC-L	•			61 (0.43)	2.5	0.84	2.3					
	P2HxxLC-L		•			1.25	3.36	9.2					
	P2HxxHF-L	•			60 (0.42)	1.61	1.92	5.1					
	P2HxxLF-L		•			0.8	7.68	20.4					
	P2HxxxH-L			•	42 (0.30)	3.68	0.44	0.50					
	P2HxxxB-L			•		1.84	1.52	1.9					
	P2HxxxC-L			•	43 (0.30)	1.77	1.68	2.3					
	P2HxxxF-L			•	42 (0.30)	1.1	3.84	5.1					
1 Stack	P21xxHA-L	•			114 (0.81)	5.6	0.23	0.80	5.5	0.0017 (0.012)	1.5 (0.68)	20 (89)	13 (58)
	P21xxLA-L		•			2.8	0.92	3.2					
	P21xxHB-L	•			111 (0.78)	4.6	0.32	1.1					
	P21xxLB-L		•			2.3	1.28	4.4					
	P21xxHC-L	•			116 (0.82)	3.5	0.53	2.3					
	P21xxLC-L		•			1.75	2.12	9.2					
	P21xxHD-L	•			109 (0.77)	1.51	2.61	10.3					
	P21xxLD-L		•			0.76	10.4	41.2					
	P21xxxA-L			•	81 (0.57)	4.0	0.46	0.80					
	P21xxxB-L			•	79 (0.56)	3.3	0.64	1.1					
	P21xxxC-L			•	82 (0.58)	2.5	1.06	2.3					
	P21xxxD-L			•	77 (0.54)	1.07	5.22	10.3					
Low Inertia	P21xxHA-J	•			111 (0.78)	5.6	0.23	0.90	5.5	0.0013 (0.0092)	1.5 (0.68)	20 (89)	13 (58)
	P21xxLA-J		•			2.8	0.92	3.6					
	P21xxxA-J			•	79 (0.56)	4.0	0.46	0.90					
	P21xxHB-J	•			108	4.6	0.33	1.2					
	P21xLLB-J		•		108	2.3	1.3	4.8					
	P21xxxB-J			•	76	3.3	0.65	1.2					
	P21xxHC-J	•			112	3.5	0.56	2.4					
	P21xxLC-J		•		112	1.75	2.22	9.6					
	P21xxxC-J			•	79	2.5	1.11	2.4					
	P21xxHD-J	•			106	1.51	2.63	10.4					
	P21xxLD-J		•		106	0.76	10.5	41.6					
	P21xxxD-J			•	75	1.07	5.25	10.4					

Note: \*Maximum shaft loading based on 20,000 hours of operation at 1500 rpm.

### M2 Enhanced 1 Stack Performance Data

	Motor Model Number	Config.			Holding Torque (2 phases on)	Rated Current/Phase	Phase Resistance	Phase Inductance	Thermal Resistance	Rotor Inertia	Weight	Shaft Loading*	
		Parallel	Series	Unipolar								Radial Force	Axial Force
					oz-in (Nm) +/-10%	Amps DC	Ohms +/-10%	mH Typical	Mounted °C/Watt	oz-in-s <sup>2</sup> (kg-m <sup>2</sup> x 10 <sup>-3</sup> )	lb (kg)		
Enhanced 1 Stack	M21xxHA-L	•			142 (1.00)	5.6	0.23	0.70	5.5	0.0017 (0.012)	1.5 (0.68)	20 (89)	13 (58)
	M21xxLA-L		•			2.8	0.92	2.8					
	M21xxHB-L	•			137 (0.97)	4.6	0.32	1.0					
	M21xxLB-L		•			2.3	1.28	4.0					
	M21xxHC-L	•			144 (1.02)	3.5	0.53	2.0					
	M21xxLC-L		•			1.75	2.12	8.0					
	M21xxHD-L	•			135 (0.95)	1.51	2.61	8.7					
	M21xxLD-L		•			0.76	10.4	34.8					
	M21xxxA-L			•	100 (0.71)	4.0	0.46	0.70					
	M21xxxB-L			•	97 (0.68)	3.3	0.64	1.0					
	M21xxxC-L			•	102 (0.72)	2.5	1.06	2.0					
	M21xxxD-L			•	95 (0.67)	1.07	5.22	8.7					
Low Inertia	M21xxHA-J	•			140 (0.99)	5.6	0.23	0.70	0.0013 (0.0092)				
	M21xxLA-J		•			2.8	0.92	2.8					
	M21xxxA-J			•	99 (0.70)	4.0	0.46	0.70					
	M21xxHB-J	•			135	4.6	0.33	1.0					
	M21xxLB-J		•		135	2.3	1.3	4.0					
	M21xxxB-J			•	95	3.3	0.65	1.0					
	M21xxHC-J	•			142	3.5	0.56	2.0					
	M21xxLC-J		•		142	1.75	2.22	8.0					
	M21xxxC-J			•	100	2.5	1.11	2.0					
	M21xxHD-J	•			133	1.51	2.63	8.6					
	M21xxLD-J		•		133	0.76	10.5	34.4					
	M21xxxD-J			•	94	1.07	5.25	8.6					

Note: \*Maximum shaft loading based on 20,000 hours of operation at 1500 rpm.

# M2 / P2 Series Stepper Motors

## P2 2 Stack Performance Data

	Motor Model Number	Config.			Holding Torque (2 phases on)	Rated Current/Phase	Phase Resistance	Phase Inductance	Thermal Resistance	Rotor Inertia	Weight	Shaft Loading*	
		Parallel	Series	Unipolar								oz-in (Nm) +/-10%	Amps DC
2 Stack	P22xxHA-L	•			197 (1.39)	6.5	0.21	0.80	4.5	0.0036 (0.025)	2.5 (1.13)	20 (89)	13 (58)
	P22xxLA-L		•			3.3	0.84	3.2					
	P22xxHB-L	•			214 (1.51)	4.6	0.38	2.1					
	P22xxLB-L		•			2.3	1.52	8.4					
	P22xxHC-L	•			203 (1.43)	3.1	0.78	3.9					
	P22xxLC-L		•			1.55	3.12	15.6					
	P22xxHD-L	•			203 (1.43)	2.5	1.22	6.2					
	P22xxLD-L		•			1.25	4.88	24.8					
	P22xxHE-L	•			195 (1.38)	1.64	2.7	12.6					
	P22xxLE-L		•			0.82	10.8	50.4					
	P22xxxA-L			•	139 (0.98)	4.6	0.42	0.80					
	P22xxxB-L			•	151 (1.07)	3.3	0.76	2.1					
	P22xxxC-L			•	144 (1.01)	2.2	1.56	3.9					
	P22xxxD-L			•	144 (1.01)	1.77	2.44	6.2					
	P22xxxE-L			•	138 (0.97)	1.16	5.4	12.6					
Low Inertia	P22xxHA-J	•			184	6.5	0.21	0.7	0.0026 (0.018)				
	P22xxLA-J		•			184	3.25	0.82					
	P22xxxA-J			•	130	4.6	0.41	0.7					
	P22xxHB-J	•			201	4.6	0.39	1.8					
	P22xxLB-J		•		201	2.3	1.54	7.2					
	P22xxxB-J			•	142	3.3	0.77	1.8					
	P22xxHC-J	•			190	3.1	0.79	3.4					
	P22xxLC-J		•		190	1.55	3.17	13.6					
	P22xxxC-J			•	134	2.2	1.59	3.4					
	P22xxHD-J	•			190	2.5	1.25	5.5					
	P22xxLD-J		•		190	1.25	4.98	22.0					
	P22xxxD-J			•	134	1.77	2.49	5.5					
	P22xxHE-J	•			182	1.64	2.73	11.1					
	P22xxLE-J		•		182	0.82	10.9	44.4					
	P22xxxE-J			•	129	1.16	5.45	11.1					

Note: \*Maximum shaft loading based on 20,000 hours of operation at 1500 rpm.

## M2 Enhanced 2 Stack Performance Data

	Motor Model Number	Config.			Holding Torque (2 phases on)	Rated Current/Phase	Phase Resistance	Phase Inductance	Thermal Resistance	Rotor Inertia	Weight	Shaft Loading*	
		Parallel	Series	Unipolar								oz-in (Nm) +/-10%	Amps DC
Enhanced 2 Stack	M22xxHA-L	•			230 (1.62)	6.5	0.21	0.70	4.5	0.0036 (0.025)	2.5 (1.13)	20 (89)	13 (58)
	M22xxLA-L		•			3.3	0.84	2.8					
	M22xxHB-L	•			253 (1.79)	4.6	0.38	1.7					
	M22xxLB-L		•			2.3	1.52	6.8					
	M22xxHC-L	•			238 (1.68)	3.1	0.78	3.1					
	M22xxLC-L		•			1.55	3.12	12.4					
	M22xxHD-L	•			238 (1.68)	2.5	1.22	5.0					
	M22xxLD-L		•			1.25	4.88	20					
	M22xxHE-L	•			227 (1.60)	1.64	2.71	10.1					
	M22xxLE-L		•			0.82	10.8	40.4					
	M22xxxA-L			•	163 (1.15)	4.6	0.42	0.70					
	M22xxxB-L			•	179 (1.26)	3.3	0.76	1.7					
	M22xxxC-L			•	168 (1.19)	2.2	1.56	3.1					
	M22xxxD-L			•	168 (1.19)	1.77	2.44	5.0					
M22xxxE-L			•	161 (1.14)	1.16	5.42	10.1						
Low Inertia	M22xxHA-J	•			229	6.5	0.21	0.60	0.0026 (0.018)				
	M22xxLA-J		•		229	3.25	0.82	2.40					
	M22xxxA-J			•	162	4.6	0.41	0.60					
	M22xxHB-J	•			252	4.6	0.39	4.0					
	M22xxLB-J		•		252	2.3	1.54	16.0					
	M22xxxB-J			•	178	3.3	0.77	4.0					
	M22xxHC-J	•			237	3.1	0.79	2.8					
	M22xxLC-J		•		237	1.55	3.17	11.2					
	M22xxxC-J			•	166	2.2	1.59	2.8					
	M22xxHD-J	•			237	2.5	1.25	4.6					
	M22xxLD-J		•		237	1.25	4.98	18.4					
	M22xxxD-J			•	166	1.77	2.49	4.6					
	M22xxHE-J	•			226	1.64	2.73	9.3					
	M22xxLE-J		•		226	0.82	10.9	37.2					
M22xxxE-J			•	160	1.16	5.45	9.3						

Note: \*Maximum shaft loading based on 20,000 hours of operation at 1500 rpm.

# M2 / P2 Series Stepper Motors

## M2 / P2 Performance Curves

P2HxxxF-L (S) w/ P5000

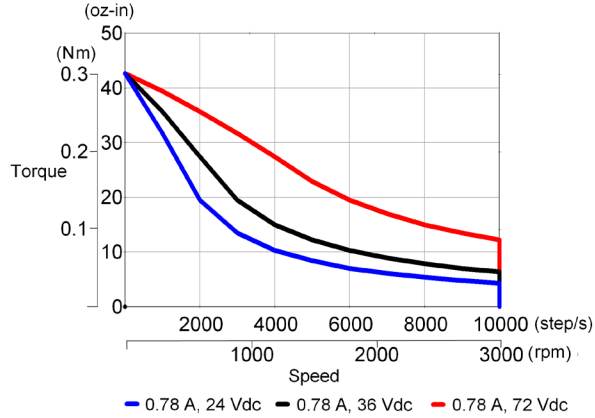

P2HxxxF-L (P) w/ P5000

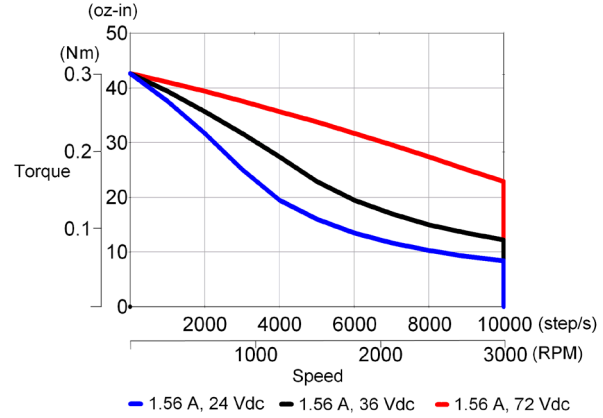

P2HxxxB-L (S) w/ P5000

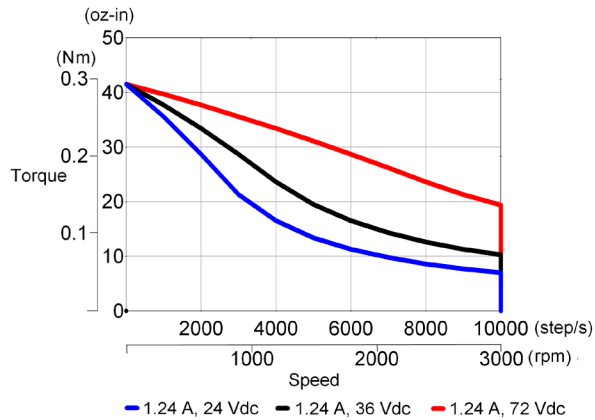

P2HxxxB-L (P) w/ P5000

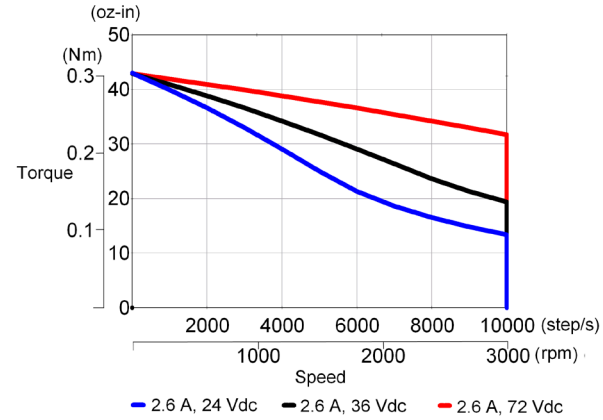

P21xxxD-L (P) w/ P5000

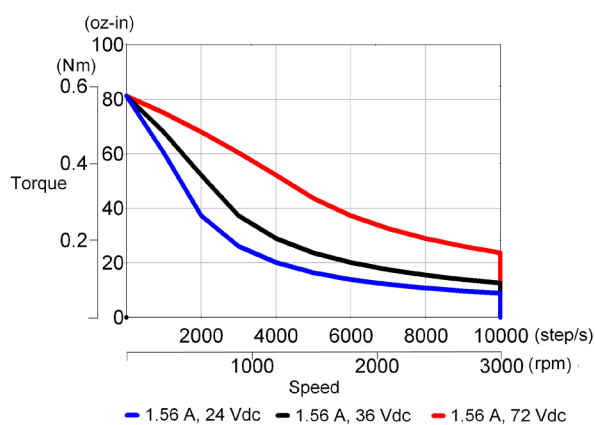

M21xxxD-L (P) w/ P5000

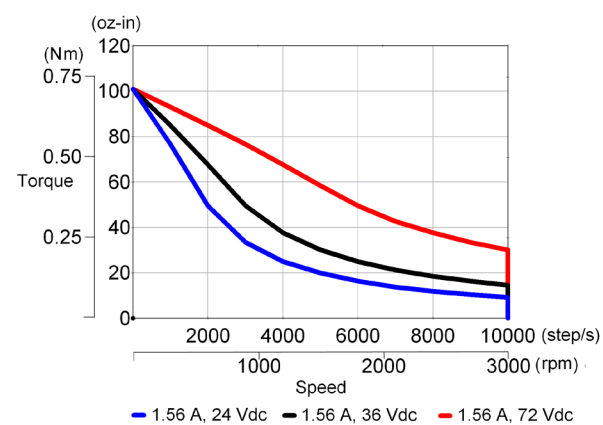



## M2 / P2 Performance Curves

**P21xxxA-L (S) w/ P5000**

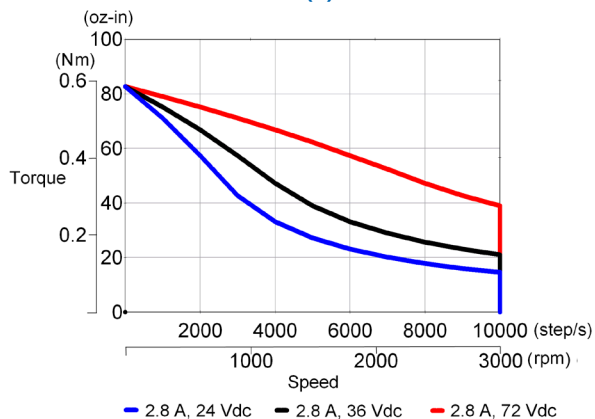

**M21xxxA-L (S) w/ P5000**

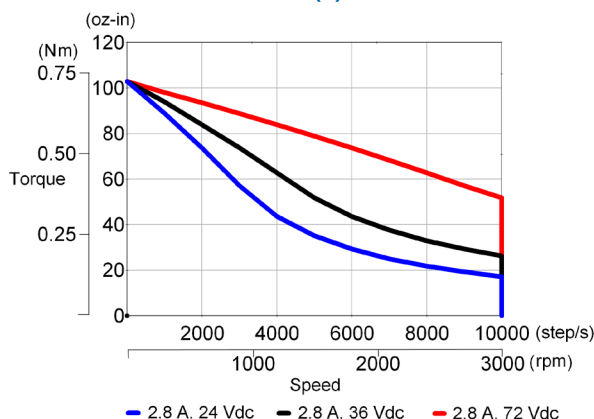

**P22xxxE-L (S) w/ P5000**

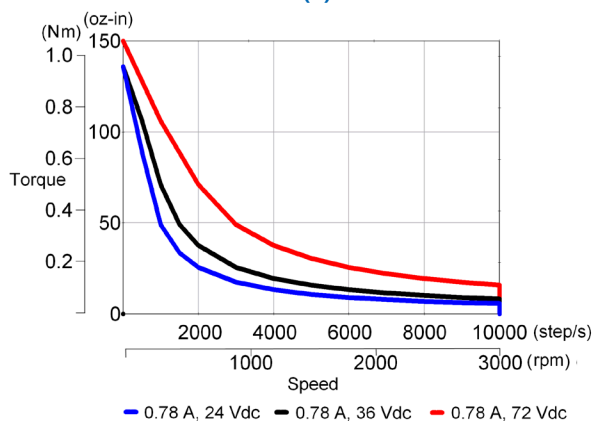

**M22xxxE-L (S) w/ P5000**

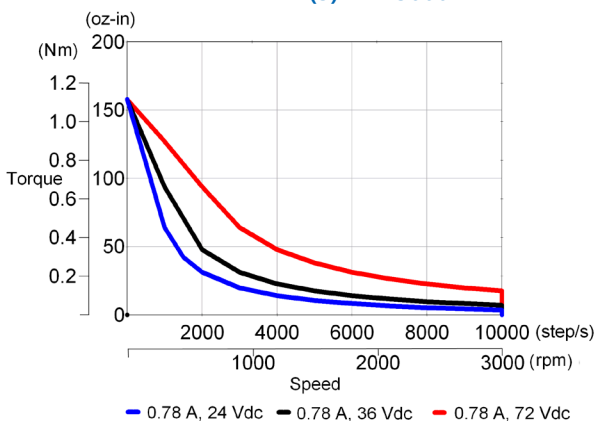

**P22xxxC-L (S) w/ P5000**

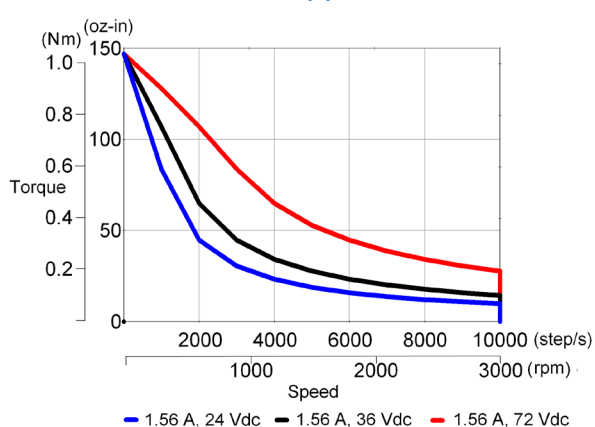

**M22xxxC-L (S) w/ P5000**

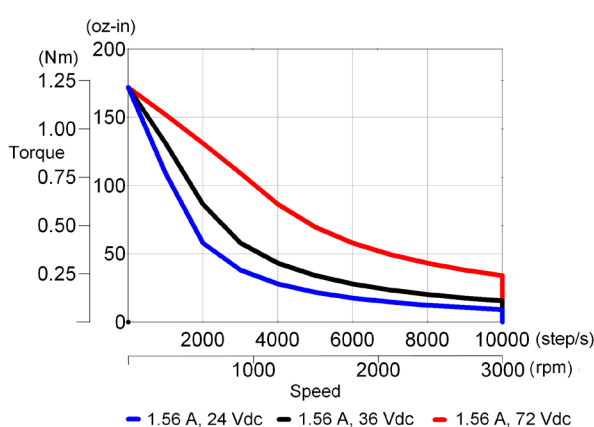

# M2 / P2 Series Stepper Motors

## M2 / P2 Performance Curves

P22xxxD-L (P) w/ P5000

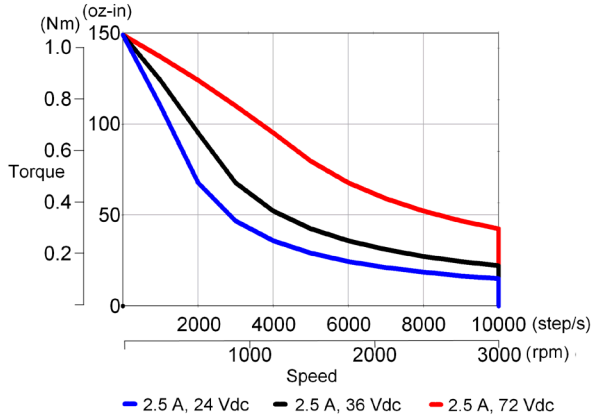

M22xxxD-L (P) w/ P5000

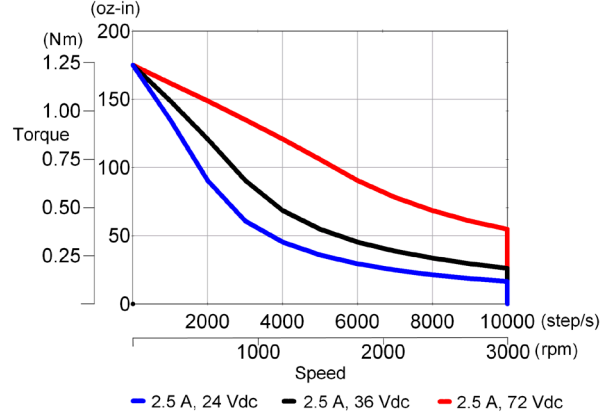

P21xxxD-L (P) w/ P6000

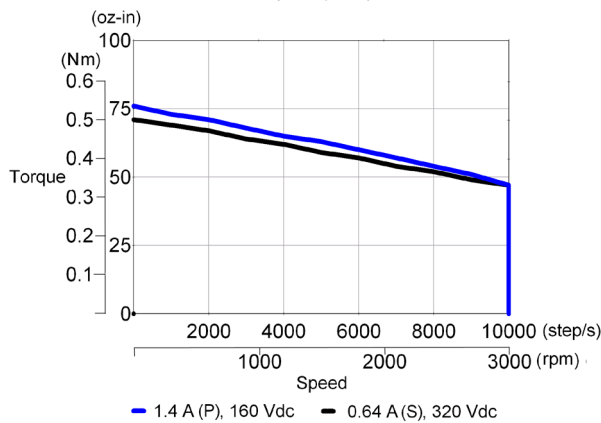

M21xxxD-L (P) w/ P6000

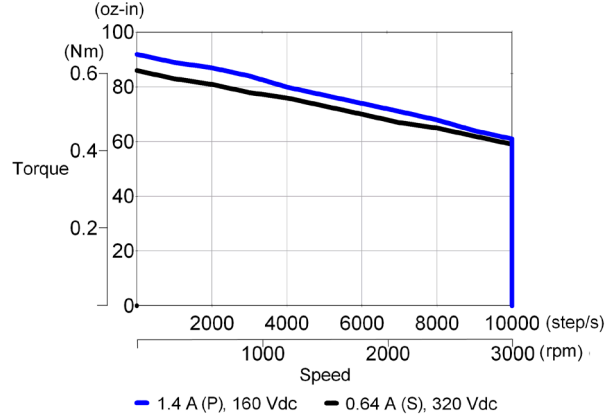

## M2 / P2 Encoder Options

### Encoder Specifications

Parameter	Code	
	HD	HJ
Type	Optical Incremental	
Supply Voltage	5 Vdc ±10%	
Lines per Revolution	500	512
Output Format	Dual Channel Quadrature with Index (Z)	
Output Type	Single-Ended	
Output Frequency (kHz)	100	
Operating Temperature (°C)	-40 to 100	
Storage Temperature (°C)	-40 to 100	

### Encoder Dimensional Drawings

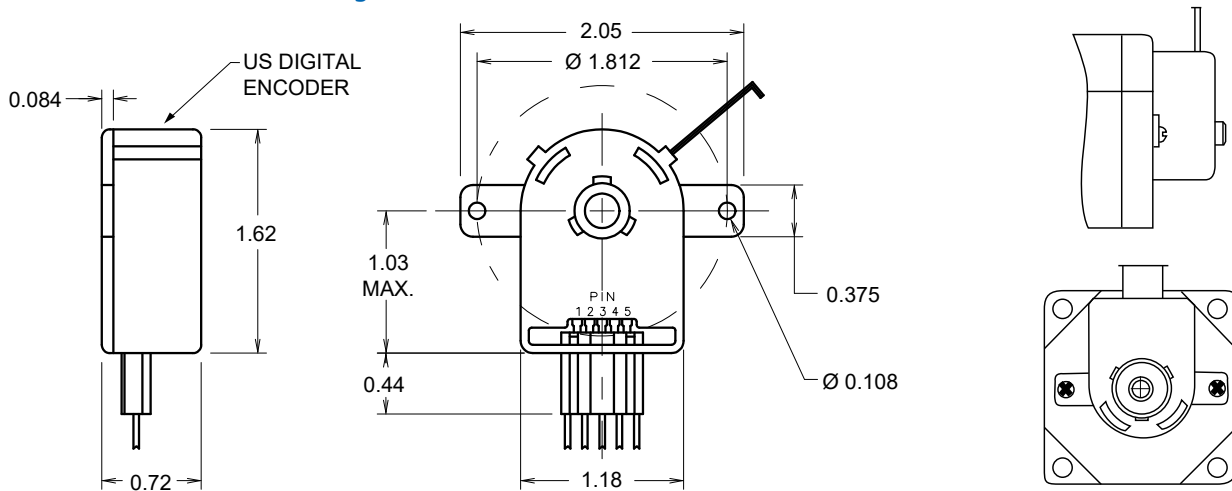

### Encoder Connection

Pin	Function	Color Code
1	GND	Brown
2	Z	Violet
3	A	Blue
4	+5 V	Orange
5	B	Yellow

### HD, HJ Encoder Phase Diagram

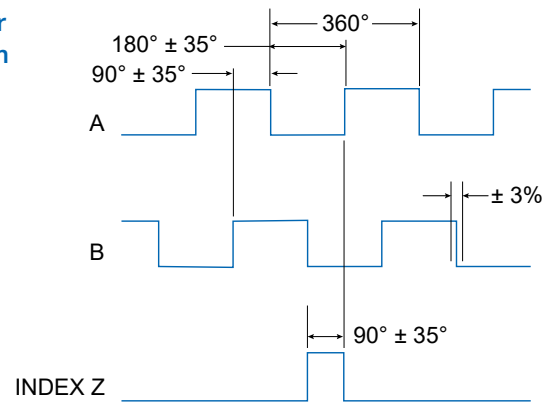

OUTPUT FORMAT FOR CCW ROTATION VIEWED FROM ENCODER END

## More Expertise for a More Successful Machine

Our global engineering, service and support network provides deep knowledge of all the major industries that rely on advanced motion control and automation technology. We offer world-class engineering expertise, self-service design tools, personalized field service, and easy access to our design, application and manufacturing centers in strategic locations across the globe.

## About Kollmorgen

Kollmorgen, a Regal Rexnord brand, has more than 100 years of motion experience, proven in the industry's highest-performing, most reliable motors, drives, linear actuators, AGV (Automated Guided Vehicle) control solutions, and automation control platforms. We deliver breakthrough solutions that combine exceptional performance, reliability and ease of use, giving machine builders an irrefutable marketplace advantage.

# KOLLMORGEN

A REGAL REXNORD BRAND

[www.kollmorgen.com](http://www.kollmorgen.com)

Specifications are subject to change without notice. It is the responsibility of the product user to determine the suitability of this product for a specific application. All trademarks are the property of their respective owners

© 2024 Kollmorgen Corporation. All rights reserved

KM\_SG\_00091-MP\_RevD\_EN