

Kollmorgen Automation Suite

Integrated Development Environment (KAS-IDE) User Manual



Document Edition: Y, June 2024

Valid for KAS Software Revision: 4.02

Valid for AKD Firmware Version: 01-23-00-000

Valid for AKD2G Firmware Version: 02-13-00-000

Part Number: 959715



For safe and proper use, follow these instructions.
Keep for future use.

Copyrights, Licenses, and Trademarks

PCMM2G

The PCMM2G's Operating System (OS) and boot loader ([U-Boot](#)) are based on free and open-source software, distributed under version 3 of the GNU General Public License as published by the Free Software Foundation. For more information about your rights and obligations with GPL-3.0, see the GNU website: [GNU General Public License](#).

The individual copyright notices, license texts, and disclaimers of warranty for the software components are located in the controller, under the directory: `/usr/share/common-licenses/`.

For more information about accessing the PCMM2G's files, see [SSH Login to a Controller](#).

The OS, bootloader, and their software component's source codes including modifications, copyright notices, license texts, disclaimers of warranty, and the compilation scripts to build the OS image are available from the Kollmorgen web-site [Kollmorgen Support Network - Downloads](#).

The OS image and its corresponding sources file is identified by an "OS-Sources" designator, followed by its version number: OS-Sources-x.xx.x.xxxxx.

The compilation scripts and sources file used to build the OS image is identified by the "OS-Build-Sources" designator, followed by its version number: OS-Build-Sources-x.xx.x.xxxxx.

See [PCMM2G - File Naming Conventions](#) in the KAS online help.

Copyrights

Copyright © 2009-2024 Regal Rexnord Corporation, All Rights Reserved.

Information in this document is subject to change without notice.

The software package described in this document is furnished under a license agreement. The software package may be used or copied only in accordance with the terms of the license agreement.

Trademarks

Regal Rexnord and [Kollmorgen](#) are trademarks of [Regal Rexnord Corporation](#) or one of its affiliated companies.

- KAS and AKD are registered trademarks of [Kollmorgen](#).
- Codemeter is a registered trademark of [WIBU-Systems AG](#).
- EnDat is a registered trademark of Dr. Johannes Heidenhain GmbH.
- EtherCAT is a registered trademark and patented technology, licensed by Beckhoff Automation GmbH.
- Ethernet/IP Communication Stack: copyright (c) 2009, Rockwell Automation.
- Ethernet/IP is a registered trademark of ODVA, Inc.
- [Ghostsript](#) is a registered trademark of Artifex Software, Inc. and is distributed under the [AGPL](#) license.
- HIPERFACE is a registered trademark of Max Stegmann GmbH.
- [PLCopen](#) is an independent association providing efficiency in industrial automation.
- PROFINET is a registered trademark of PROFIBUS and PROFINET International (PI).
- SIMATIC is a registered trademark of SIEMENS AG.
- SyCon® is a registered trademark of [Hilscher GmbH](#).
- Windows® is a registered trademark of Microsoft Corporation.

Kollmorgen Automation Suite is based on the work of:

- [7-zip](#) (distributed under the terms of the LGPL and the BSD 3-clause licenses - [see terms](#))
- [curl](#) software library
- [JsonCpp](#) software (distributed under the MIT License – [see terms](#))
- [Mongoose](#) software (distributed under the MIT License - [see terms](#))
- [Qt](#) cross-platform SDK (distributed under the terms of the LGPL3; Qt source is available on KDN)
- [Qwt](#) project (distributed under the terms of the [Qwt License](#))
- The [C++ Mathematical Expression Library](#) (distributed under [the MIT License](#))
- [U-Boot](#), a universal boot loader is used by the AKD PDMM and PCMM (distributed under the [terms](#) of the GNU General Public License). The U-Boot source files, copyright notice, and readme are available on the distribution disk that is included with the AKD PDMM and PCMM.
- [Zlib](#) software library

All other product and brand names listed in this document may be trademarks or registered trademarks of their respective owners.

Disclaimer

Technical changes which improve the performance of the device may be made without prior notice!

This document is the intellectual property of Kollmorgen. All rights reserved. No part of this work may be reproduced in any form (by photocopying, microfilm or any other method) or stored, processed, copied or distributed by electronic means without the written permission of Kollmorgen.

The information in this document is believed to be accurate and reliable at the time of its release. Kollmorgen assumes no responsibility for any damage or loss resulting from the use of this help, and expressly disclaims any liability or damages for loss of data, loss of use, and property damage of any kind, direct, incidental or consequential, in regard to or arising out of the performance or form of the materials presented herein or in any software programs that accompany this document.

All timing diagrams, whether produced by Kollmorgen or included by courtesy of the PLCopen organization, are provided with accuracy on a best-effort basis with no warranty, explicit or implied, by Kollmorgen. The user releases Kollmorgen from any liability arising out of the use of these timing diagrams.

Table of Contents

1 Preface	40
1.1 System Requirements	40
2 Introducing Kollmorgen Automation Suite	41
2.1 Learning Kollmorgen Automation Suite	42
2.1.1 Where to Start	42
2.1.1.1 Beginner	42
2.1.1.2 Advanced User	42
2.1.1.3 Online	42
2.1.2 Read the KAS Manuals	43
2.2 Key Features	45
2.2.1 Kollmorgen Automation Suite-Integrated Development Environment (KAS-IDE)	46
2.2.2 KAS Runtime	47
2.2.3 KAS Simulator	47
2.3 Looking at Kollmorgen Automation Suite	47
2.3.1 Architectural View	47
2.3.1.1 Real-Time	48
2.3.1.2 Non-Real-Time	48
2.3.2 Logical View	49
2.3.3 Physical View	51
2.4 Kollmorgen Automation Suite (KAS) Breakdown	53
2.4.1 Human-Machine Interface	58
2.4.2 Controllers	58
2.4.2.1 AKD PDMM and PCMM Hardware	59
2.4.2.2 Controller Rotary Switch	60
2.4.2.3 Controller Web Server	60
2.4.2.4 Controller Performance	61
2.4.2.4.1 Examples: Performance Graphs	61
2.4.2.4.2.1 Single Core	61
2.4.2.4.3.2 Dual Core	62
2.4.2.4.4.3 PCMM2G Controllers	62
2.4.2.4.5 Application Complexities	63
2.4.2.4.6.1 High Complexity	63
2.4.2.4.7.2 Middle Complexity	64
2.4.2.4.8.3 Low Complexity	64
2.4.2.4.9 Pipe Network and PLCopen Applications	65
2.4.2.4.10 Performance FAQs	65
2.4.3 Communication and Fieldbus	66
2.4.3.1 Fieldbus	66
2.4.3.2 Motion Bus	66
2.4.3.3 Ethernet	66
2.4.3.3.1 EtherCAT	66
2.4.4 Input/Output Bus	66
2.4.5 Drives	67
2.4.6 Kollmorgen Motors	67
2.4.6.1 Servomotors	67
2.4.6.2 Cartridge Motors	68

2.4.6.3	Direct Drives	68
2.5	Different Implementations	68
2.5.1	Single-Axis with AKD PDMM	68
2.5.2	Multi-Axis with AKD PDMM, PCMM, or PCMM2G	69
3	Describing the KAS Graphical User Interface	70
3.1	Windows and Panels Overview	70
3.1.1	Main Window	70
3.1.2	Toolboxes	71
3.1.3	Project Explorer	71
3.1.3.1	System	72
3.1.3.2	Controller	72
3.1.3.3	Controller Node - Context Menu	72
3.1.3.3.1	PLC	74
3.1.3.3.2	Programs	75
3.1.3.3.3	Program Item - Contextual Menu	75
3.1.3.3.4	Subprograms	76
3.1.3.3.5	Subprogram Item - Context Menu	76
3.1.3.3.6	Defines	76
3.1.3.3.7	Motion	76
3.1.3.3.8	Profiles	76
3.1.3.3.9	Pipe Network	77
3.1.3.4	PLCopen	78
3.1.3.4.1	Axes	78
3.1.3.4.2	Axes Groups	78
3.1.3.5	Control Panel	79
3.1.3.5.1	Controller Onboard I/O	79
3.1.3.5.2	EtherCAT	79
3.1.3.5.3	AKD2G Drive	79
3.1.3.5.4	AKD Drive	80
3.1.3.5.5	AKD-C Central Power Supply	80
3.1.3.5.6	AKD-N Drive	80
3.1.3.5.7	AKT (K-Bus) I/O Coupler	80
3.1.3.5.8	AKT2G (EtherCAT) I/O Coupler	81
3.1.3.5.9	I/O Slice	81
3.1.3.5.10.1	Device	81
3.1.3.5.11	Module	81
3.1.3.6	References	81
3.1.3.6.1	Fieldbus	82
3.1.3.7	HMI Device	82
3.1.3.7.1	KVB Project	82
3.1.3.8	SafePLC2 Project	82
3.1.3.8.1	Access the Web server From the KAS-IDE	82
3.1.3.8.2.1	Export a Control Panel	83
3.1.3.8.3.2	Import a Control Panel	84
3.1.4	Libraries	85
3.1.4.1	Function Blocks	85
3.1.4.2	Controls	85
3.1.4.3	Properties	86

3.1.5 Dictionary	86
3.1.5.1 Variables tab	86
3.1.5.1.1 Variables	90
3.1.5.1.2 Structures	91
3.1.5.1.3 Variable Editor	92
3.1.5.1.4.1 Create a New Variable	93
3.1.5.1.5 Variable Table List	93
3.1.5.1.6 Sort Variables	94
3.1.5.1.7 Define Structures	94
3.1.5.1.8 Name a Variable	94
3.1.5.1.9.1 Name Physical I/Os	94
3.1.5.1.10.2 Change the Name of an I/O Variable	95
3.1.5.1.11 Rename Variables	95
3.1.5.1.12 Variable Initial Value	97
3.1.5.1.13 Variable Tag and Description	97
3.1.5.1.14.1 Change the Tag or Description of a Variable	97
3.1.5.1.15 Edit Variables as Text using IEC 61131-3 Syntax	97
3.1.5.1.16.1 Basic Syntax for Declaring a Variable	98
3.1.6 Data Type: STRING	98
3.1.7 Read-only Attribute	98
3.1.8 Declare an Array	98
3.1.9 Single Variable Input Value	98
3.1.9.0.1.1 Additional Information and Description Texts	99
3.1.9.1 Enum tab	99
3.1.9.1.1 Adding Enums	99
3.1.9.1.2 Create Enums	100
3.1.9.1.3 Declaring Enums	100
3.1.9.2 Bit Fields tab	100
3.1.9.2.1 Adding Bit Fields	101
3.1.9.2.2 Using Bit Fields	101
3.1.10 Information and Logs window	102
3.1.10.1 Log Messages tabs	103
3.1.10.2 Log Messages Settings	104
3.1.10.2.1 Configuration Settings	104
3.1.10.2.2 Filtering	107
3.1.10.2.3.1 Filtering Rules	108
3.1.10.2.4.2 Log Scrolling	108
3.1.10.3 Find and Replace tab	108
3.1.10.3.1 Location Details	110
3.1.10.4 Find and Replace Operations	111
3.1.10.4.1 Information and Logs	111
3.1.10.4.2 Dictionary	111
3.1.10.4.3 Editor	111
3.1.10.5 Browse Variable tab	112
3.1.10.5.1 Using the Browse Variable tab	113
3.1.10.5.2 Using the Dictionary's Browse Variable menu item	113
3.1.10.6 Breakpoints tab	114
3.1.10.7 Compiler Output tab	115

3.1.11 Watch Window	117
3.1.11.1 Multiple Watch Windows	117
3.1.11.2 Access Structure and Arrays	118
3.1.11.3 Add Variable	118
3.1.11.4 Add an Expression	119
3.1.11.5 Force a Variable	120
3.1.12 AKD Drive	122
3.1.12.1 WorkBench Toolbar	122
3.1.12.2 WorkBench Status Bar	122
3.1.13 Status Bar	123
3.1.13.1 Local Version	123
3.1.13.2 Controller Version	123
3.1.13.3 Drives State	123
3.1.13.4 Controller State	125
3.1.13.5 Connection State	125
3.1.13.6 Color Codes	125
4 Getting Started	128
4.1 KAS-IDE to Runtime Compatibility	128
4.2 KAS PLC Code to Runtime Compatibility	129
4.3 KAS-IDE to Project File Compatibility	129
4.4 Start the KAS-IDE	130
4.4.1 Find the KAS-IDE Version	130
4.4.2 Access Help System	131
4.4.3 KAS GUI	131
4.4.4 KAS-IDE Log Window	131
4.4.4.1 Log Information	131
4.4.5 Create a Project	132
4.4.6 Add and Configure a Controller	133
4.4.6.1 Add the Controller	133
4.4.6.1.1 Available Application Templates	133
4.4.6.1.2 Coordinated Motion	133
4.4.6.1.3 KAS Runtime	134
4.4.6.1.4 KDN Download	134
4.4.6.1.5 Pipe Network	134
4.4.6.1.6 PLCopen	134
4.4.6.2 Configure the Controller	135
4.4.7 Configure EtherCAT Motion Bus	138
4.4.7.1 Slave Devices	138
4.4.7.2 EtherCAT Scan and Association	138
4.4.7.3 Scan and Associate Network Devices	140
4.4.7.3.1 Unknown – Missing ESI File	141
4.4.7.3.2 Missing ESI File - MDP Device	142
4.4.7.4 Re-Scan and Change Device Associations	143
4.4.7.5 Re-Scan and Change Coupler/Slice Associations	145
4.4.7.5.1 EtherCAT Scan & Association Example 1 - Associating Couplers and I/O Slices	145
4.4.7.5.2 EtherCAT Scan & Association Example 2 - Adding Physical I/O Slices	147
4.4.7.6 Re-Scan and Change Device/Module Associations	149
4.4.7.6.1 EtherCAT Scan & Association Example 3 - Add a Module to a Device	149

4.4.7.6.2 EtherCAT Scan & Association Example 4 - Remove a Module From a Device	151
4.4.8 Create a Program	154
4.4.8.1 Create Variables	155
4.4.8.2 Create and/or Call Functions & Function Blocks	156
4.4.8.3 Using Constants	157
4.4.8.4 Map Input and Output to Variables	157
4.4.9 Adding Motion	158
4.4.9.1 Design Motion with Pipe Network	158
4.4.9.1.1 Create the Pipe Network	158
4.4.9.1.2 Edit Properties of Pipe Blocks	160
4.4.9.1.3 Map the Axis to the Drive	160
4.4.9.1.4 Add Comments to Pipe Network	161
4.4.9.1.5 Set the Axis Block Position Units	161
4.4.9.1.6 Show Pipe Network and Profiles-Generated Code	162
4.4.9.1.7 Pipe Network Functions for the PLC	162
4.4.9.1.8 Initialize and Start a Pipe Network	163
4.4.9.1.9 How the Pipe Network interacts with PLC programs	164
4.4.9.2 Design Motion with PLCopen Axis	166
4.4.9.2.1 Create a PLCopen Axis	166
4.4.9.2.2 Modify PLCopen Axis	166
4.4.9.2.3.1 Axis Name and Number	167
4.4.9.2.4.2 Common Axis Parameters	169
4.4.9.2.5.3 Digitizing Axis Parameters	170
4.4.9.2.6.4 Axis Data Parameters	172
4.4.9.2.7.5 Axis Limits Parameters	173
4.4.9.2.8 Create PLCopen Axes Groups	174
4.4.9.2.9 Initialize and Start PLCopen	175
4.4.9.3 Design Coordinated Motion	175
4.4.9.3.1 Create a Linear or Circular Coordinated Motion Application	176
4.4.10 Groups	176
4.4.10.0.1.1 Function Block Calls	176
4.4.10.0.2.2 What are Axes Groups?	179
4.4.10.0.3.3 Perform a Circular Move	179
4.5 Absolute Circular Move	179
4.6 Relative Circular Move	180
4.6.0.0.1.1 Perform a Linear Move	181
4.7 Absolute Linear Move	181
4.8 Relative Linear Move	182
4.9 Linear Move With More Than Two Axes	183
4.9.0.0.1.1 Circular Moves Diagrams	183
4.10 CircMode = BORDER	183
4.11 CircMode = CENTER	183
4.11.1 Add an HMI Device	185
4.11.1.1 Create a KVB Project	185
4.11.1.2 Map Variables to HMI	186
4.11.1.2.1.1 Variables to Export	187
4.11.1.2.2.2 Structures to Export	187
4.11.1.2.3.3 Structure that Cannot be Exported	187

4.11.1.3 Design KVB Panel with Kollmorgen Visualization Builder	188
4.11.2 SafePLC2 Projects	189
4.11.3 Overview: Compile, Connect, Download, and Run	190
4.11.4 Create Project - Advanced	190
4.11.5 Add and Configure a Servo Drive	190
4.11.5.1 Add the Drive	190
4.11.5.2 Configure the AKD / AKD2G Drive	191
4.11.5.3 Save Parameters to Non-Volatile Memory	193
4.11.5.4 AKD Setup Wizard	193
4.11.5.5 Configure Onboard I/O	194
4.11.5.6 Digital Input Mode	194
4.11.5.6.1 How to configure Digital Input mode setting inside WorkBench	195
4.11.6 Add and Configure a Stepper Drive	195
4.11.6.1 AKT2G-IO-SM-Lxx Stepper Drive I/O Tab	196
4.11.6.2 AKT2G-IO-SM-Lxx Stepper Drive Configuration tab	196
4.11.6.2.1 Properties tab	197
4.11.6.2.2 Mode Section	197
4.11.6.2.3 Drive Section	198
4.11.6.2.4 Motor Section	199
4.11.6.2.5 Encoder Section	199
4.11.6.2.6 Diagnostics tab	200
4.11.7 Add and Configure I/O Slices	201
4.11.7.1 Add an AKT (K-Bus) I/O Coupler	201
4.11.7.2 Add an AKT (K-Bus) I/O Slice	202
4.11.7.3 Add an AKT2G-IO Stepper Drive	202
4.11.7.4 Configure the I/O Slice	203
4.11.8 Add and Configure Third Party Devices	204
4.11.8.1 Add Modules to Third Party EtherCAT Devices	206
4.11.8.1.1 Limitations	206
4.11.8.2 Modules - General Properties Tab	207
4.11.9 Use Pre-defined Libraries	208
4.11.10 Create and Use Custom Libraries	209
4.11.10.1 Create a Custom Library	209
4.11.10.2 Use the Custom Library	210
4.11.11 Adding Cam Profiles	213
4.11.11.1 Create a CAM Profile	213
4.11.11.1.1 CAM Profile Parameters	213
4.11.11.1.2.1 Four Parameters Transforming the CAM Profile	214
4.11.11.2 Use Cam Profiles	216
4.11.11.3 CAM Profile Switching	217
4.11.12 Define Scheduling	218
4.11.12.1 Periodicity	218
4.11.12.2 Order of Execution	218
4.11.12.3 Define the PLC Cycle	219
4.11.12.3.1 Specify the Duration of a Cycle	220
4.11.12.3.2 Ensuring Variables are Exported	220
4.11.12.4 About Parent-Child relationships and execution order	221
4.12 Run the Project	222

4.12.1 Set the Compilation Options	222
4.12.1.1 Code Generation	222
4.12.1.1.1 Normal	222
4.12.1.1.2 Optimized	223
4.12.1.2 Conditional Compiling	223
4.12.2 Compile the Project	225
4.12.3 Start the KAS Simulator	226
4.12.4 Connect to the Controller	226
4.12.4.1 Actions to Prevent Compatibility Issues	227
4.12.4.2 Application Status Bar	227
4.12.4.3 Message Window	228
4.12.5 Download the Project	228
4.12.5.1 Project Name - Same Name	228
4.12.5.1.1 Actions	228
4.12.5.2 Project Name - Different Name	229
4.12.5.2.1 Actions	230
4.12.5.3 Application Status Bar	230
4.12.6 Device Control	230
4.12.6.1 Start / Stop the Device	230
4.12.6.2 Log Window	230
4.13 Testing and Debugging the Project	231
4.13.1 Step-By-Step Debugging	231
4.13.2 Breakpoints	232
4.13.2.0.1 Online Change	233
4.13.3 Setting, Removing, Enabling, and Disabling Breakpoints	234
4.13.3.1 How to Set Breakpoints	234
4.13.3.1.1 About SFC	234
4.13.3.2 How to Enable/Disable a Breakpoint	235
4.13.4 Printf	235
4.13.4.1 Customize Output in the Log Window	235
4.13.5 Soft Oscilloscope Debugging	236
4.13.5.1 Plug Motion Variables	236
4.13.5.1.1 Usage example with the Pipe Network	237
4.13.5.2 Plug PLC Variables	238
4.13.6 Compare PLC Programs	239
4.13.6.1 Limitations of FFLD Diagrams	240
4.13.7 Variable Animation	240
4.13.7.0.1 About Online Change	241
4.13.7.0.2 Limitations	241
4.13.7.1 Variable Monitoring	241
4.13.7.1.1 Monitoring UDFBs	241
4.13.7.1.2 Forcing a Variable	242
4.13.7.2 IEC 61131-3 Editor Debugging	243
4.13.7.3 Pipe Network Editor Debugging	244
4.14 Managing a Project	244
4.14.1 Print	244
4.14.1.1 Printable Elements	244
4.14.1.2 Page Setup	245

4.14.1.3 Print	245
4.14.1.4 Print Preview	245
4.14.1.5 Print Project	245
4.14.2 Use the Reference Folder	246
5 KAS IDE Reference	247
5.1 Choose a Workspace Layout	247
5.1.1 Move Child Windows	247
5.1.2 Move Toolbox	247
5.1.3 Dock Window	247
5.2 Menus and Toolbar Overview	249
5.2.1 Menus	249
5.2.2 Toolbars	249
5.2.3 Debug toolbar	249
5.2.4 Device Toolbar	250
5.2.5 File menu	251
5.2.6 Edit menu	254
5.2.7 EtherCAT Toolbar	255
5.2.8 Help menu	255
5.2.9 Main Toolbar	255
5.2.10 Online Change Toolbar	256
5.2.11 Tools menu	256
5.2.11.1 User Options	257
5.2.11.1.1 AKD GUI Scope Settings	257
5.2.11.1.2 AutoSave Recovery File Settings	257
5.2.11.1.3 Backup File Settings	258
5.2.12 Window menu	258
5.3 Windows Standard Conventions	259
5.3.1 Windows Manipulation	259
5.3.2 Mouse Manipulation	260
5.3.3 Table Manipulation	260
5.3.3.1 Sorting Items	260
5.3.3.2 Selecting a Cell	260
5.3.3.3 Selecting a Row	260
5.3.3.4 Resizing a Column	260
5.4 Keyboard Shortcuts	260
5.4.1 Common Keyboard Shortcuts	261
5.4.2 FBD Editor Keyboard Shortcuts	262
5.4.2.1 FBD Editor (common)	262
5.4.2.2 FBD Editor (when editing)	262
5.4.2.3 FBD Editor (during debug)	262
5.4.3 FFLD Editor Keyboard Shortcuts	263
5.4.3.1 FFLD Editor (when editing)	263
5.4.3.1.1 Insert	263
5.4.3.1.2 Trace	263
5.4.3.1.3 Move	265
5.4.3.1.4 Select	265
5.4.3.1.5 Edit	266
5.4.3.1.6 Find	266

5.4.3.1.7 Delete	266
5.4.3.1.8 Bookmark	266
5.4.3.2 FFLD Editor (during debug)	266
5.4.4 Graphic Editor Keyboard Shortcuts	266
5.4.5 SFC Editor Keyboard Shortcuts	267
5.4.6 ST Editor Keyboard Shortcuts	268
5.4.6.1 ST Editor (common)	268
5.4.6.2 ST Editor (when editing)	268
5.4.6.3 ST Editor (during debug)	268
5.4.7 Table Keyboard Shortcuts	268
5.5 Bookmarks	269
5.6 Programs: Structure and Syntax	269
5.6.1 Project Structure	269
5.6.2 IEC 61131-3 Editors	269
5.6.3 Tips	270
5.6.3.1 Drag-and-Drop	270
5.6.3.2 Auto-completion	270
5.6.3.3 Tooltip on Variable	270
5.6.3.4 Bookmarks	271
5.6.4 Select Function Blocks	271
5.6.5 Select Variables and Instances	271
5.6.6 Drag and Drop Programming	271
5.6.7 Autocompletion When Programming	272
5.6.8 Tooltips on Variables	272
5.6.9 Selecting Function Blocks	272
5.6.10 Selecting Variables and Instances	273
5.6.11 Change Operators and Functions in FBD or FFLD Editors	273
5.6.12 Change Function Blocks in FBD or FFLD Editors	274
5.6.13 Function Block Diagram (FBD) Editor	274
5.6.13.1 Using the FBD Toolbar	276
5.6.13.1.1 FBD Variables	278
5.6.13.1.2 FBD Comments	279
5.6.13.1.3 FBD Corners	279
5.6.13.1.4 FBD Network Breaks	280
5.6.13.1.5 FBD OR Vertical Rail	280
5.6.13.2 Draw FBD Connection Lines	280
5.6.13.3 Select FBD Variables and Instances	281
5.6.13.4 View FBD Diagrams	282
5.6.13.5 Move or Copy FBD Objects	282
5.6.13.5.1 Use the Keyboard	282
5.6.13.5.2.1 Move Objects	282
5.6.13.5.3.2 Extend Object Selection	283
5.6.13.5.4.3 Insert or Delete Space	283
5.6.13.5.5.4 Auto-alignment	283
5.6.13.6 Insert FBD Objects on a Line	283
5.6.13.7 Resize FBD Objects	283
5.6.14 Free Form Ladder Diagram (FFLD) Editor	284
5.6.14.1 Advanced Graphic Features	284

5.6.14.1.1	Change Ladder Diagram Size	284
5.6.14.1.2	Color-coded Functions	284
5.6.14.1.3	Coordinate-based Positions	285
5.6.14.1.4	Select the Entire Ladder Diagram	285
5.6.14.1.5	Split Window Capability	286
5.6.14.2	FFLD Toolbar and Right-click Menu	286
5.6.14.2.1	Toolbar	286
5.6.14.2.2	Right-click Menu	288
5.6.14.3	FFLD Networks	288
5.6.14.3.1	Header Row	288
5.6.14.3.2	New Networks	289
5.6.14.4	FFLD Runtime	289
5.6.14.5	FFLD Power Rail and Lines	289
5.6.14.6	FFLD Contacts and Coils	290
5.6.14.7	FFLD Function Blocks	290
5.6.14.8	FFLD Data In / Data Out	290
5.6.14.9	FFLD Jumps and RETURN	291
5.6.14.10	FFLD Selection Grid	291
5.6.14.11	FFLD Move and Copy Items	292
5.6.14.12	View FFLD Diagrams	293
5.6.15	Sequential Function Chart (SFC) Editor	293
5.6.15.1	Using the SFC Toolbar	294
5.6.15.1.1	Edition window	295
5.6.15.2	Draw SFC Divergences	295
5.6.15.2.1	Simple or Double Divergence Lines	296
5.6.15.3	View SFC Charts	297
5.6.15.4	Move or Copy SFC Charts	297
5.6.15.5	Renumber Steps and Transitions	297
5.6.15.6	Enter Actions of a Step	298
5.6.15.7	Enter the Condition of a Transition	298
5.6.15.8	Enter Notes for Steps and Transitions	298
5.6.16	Structured Text (ST) / Instruction List (IL) Editor	299
5.6.16.1	ST / IL Language Selection	299
5.6.16.2	ST / IL Syntax Coloring	299
5.6.16.3	Intellisense	300
5.6.16.4	Auto-completion of Words	301
5.6.16.4.1	Other Syntax-related Commands	302
5.6.16.5	ST / IL Drag-and-Drop	302
5.6.16.6	Read the Output of a MC Function Block in ST	302
5.6.16.6.1.1	Example 1	302
5.6.16.6.2.2	Example 2	302
5.7	Create Variables	303
5.7.1	Use the Dictionary	303
5.7.2	Create Variables from the Editors	303
5.7.3	Data Types	304
5.7.4	Complex Structures	305
5.7.4.1	Declare the Structure	305
5.7.4.2	Create an Instance of the Structure	306

5.7.5 Variable Editor	306
5.7.6 Edit Variables as Text	307
5.8 Create Functions and Function Blocks	308
5.8.1 Declare Functions or Function Blocks	308
5.8.2 Define Parameters and Private Variables	310
5.8.3 Finalize Functions or Function Blocks	311
5.8.4 Call Functions or Function Blocks	311
5.9 Use the Defines List	311
5.9.1 Internal Defines	312
5.9.1.1 Example: Pre-defined Constants	312
5.9.2 Global Defines	313
5.9.2.0.1 Definition Inside Another Definition	313
5.9.2.1 Local Definitions	313
5.10 Map Input and Output to Variables	314
5.10.1 Map I/O from the Project Explorer	314
5.10.2 PLC Variable Creation Wizard	317
5.10.3 PLC Variable Selector	318
5.10.3.1 Create PLC Variable Button	318
5.10.3.2 Advanced Button	319
5.10.4 Analog I/O Parameters	320
5.10.4.1 AKT2G Input Terminals	320
5.10.4.2 AKT2G Output Terminals	320
5.10.4.3 AKT Input Terminals	320
5.10.4.4 AKT Output Terminals	321
5.11 Configuring EtherCAT	322
5.11.1 EtherCAT Devices tab	322
5.11.1.1 Scan Devices	325
5.11.1.1.1 Scan Limitations	327
5.11.2 EtherCAT Master Settings tab	327
5.11.2.0.1 Bandwidth Calculation Algorithm	328
5.11.3 ENI File tab	329
5.11.3.1 Import or Export an EtherCAT ENI File	329
5.11.3.2 Use an Imported ENI File	329
5.11.4 ESI Files tab	330
5.11.5 FSoE / PDO Connections tab	331
5.11.6 ESI Files with References (MDP)	333
5.11.6.1 EtherCAT Device Configuration - MDP Devices	334
5.11.7 ESI File Management	334
5.12 EtherCAT Devices	335
5.12.1 EtherCAT Device General Properties Tab	335
5.12.1.1 Information	336
5.12.1.2 Topology	336
5.12.2 Map I/O from the Project Explorer	337
5.12.3 Configuration tab	340
5.12.4 PDO Selection/Mapping tab	340
5.12.4.1 Map PLC Variable to PDO Object	341
5.12.4.2 Select Input and Output PDOs	343
5.12.4.3 View the Contents of a PDO	343

5.12.4.4	Set Up a Variable to Monitor Safety Data	344
5.12.5	PDO Editor tab	346
5.12.5.1	Editable PDOs	347
5.12.5.1.1	Add a Flexible PDO	348
5.12.5.1.2	Edit a Flexible PDO	348
5.12.5.1.3	Delete a Flexible PDO	349
5.12.5.2	PDO Content	349
5.12.5.2.1	Add a CoE Object	350
5.12.5.2.2	Rename a CoE Object	350
5.12.5.2.3	Delete a CoE Object	351
5.12.5.3	PDO Restrictions and Compiler Errors	351
5.12.5.3.1	Restrictions for AKD Devices	351
5.12.5.3.2	Restrictions for AKD2G Devices	352
5.12.5.3.3	Restrictions for All Other Devices	352
5.12.5.4	Redundant PDO Entries	352
5.12.5.4.1	Redundant Rx PDO	353
5.12.5.4.2	Redundant Tx PDO	353
5.12.5.5	About Safety, PDOs, and Variables	353
5.12.6	Distributed Clock tab	354
5.12.6.1	Oversampling devices	355
5.12.7	CoE Init Commands tab	356
5.12.7.0.1	Functions	356
5.12.7.1	Adding CoE Commands	357
5.12.8	CoE Object Dictionary Tab	359
6	Using the KAS Simulator	361
6.1	Start the KAS Simulator	361
6.1.1	KAS Runtime Log window	362
6.2	Stop KAS Simulator	363
6.3	KAS Simulator window	364
6.4	KAS Simulator Graphical User Interface	365
6.4.1	Main window	365
6.4.2	Log window	366
6.5	KAS Simulator Menus Description	366
6.5.1	File Menu	366
6.5.2	Help Menu	367
7	Migrate from a PxMM to a PCMM2G Controller	368
7.1	Prepare the User .KAS Project for Migration	368
7.2	PCMM2G Hardware Preparation	368
7.3	PCMM2G Configuration	370
7.4	User .KAS Project Migration	371
8	Using the Controllers	374
8.1	Booting the AKD PDMM or PCMM Controller	374
8.2	Booting the PCMM2G Controller	375
8.2.1	Active Partition	375
8.2.2	Boot Partition	375
8.2.3	Data Partition	375
8.2.4	Inactive Partition	375
8.3	Boot from Inactive Partition Image - PCMM2G	376

8.3.0.1	Operational Image	376
8.3.0.2	Fallback Image	376
8.3.1	Boot Failure	376
8.3.2	Fallback Mode	376
8.3.2.1	Boot into Fallback Mode	376
8.3.3	Limitations	377
8.3.4	Recovery Mode	377
8.4	Boot Sequence	377
8.4.1	AKD PDMM or PCMM Boot Sequence	378
8.4.2	PCMM2G Boot Sequence	378
8.4.2.1	Internal Flash	378
8.4.2.2	Recovery USB Drive	379
8.5	Boot from Recovery Image (B2 Button)	379
8.5.1	AKD PDMM and PCMM Only	380
8.6	Controller Boot Startup Script	380
8.6.1	AKD PDMM and PCMM Flow	380
8.6.2	PCMM2G Flow	382
8.7	Use the Controller Buttons	382
8.7.1	Button Functionality	382
8.7.1.1	Power-up	382
8.7.1.2	Running	383
8.7.2	B3 Menu Button	383
8.7.2.0.1	Access Functions Menu	383
8.7.2.1	Application is Running	383
8.7.2.2	Application is Not Running	383
8.7.3	View the Controller IP Address	384
8.7.4	Boot from Recovery Image (B2 Button)	384
8.7.4.1	AKD PDMM and PCMM Only	384
8.7.5	Reset the Controller to Factory Settings	385
8.7.5.1	Factory Reset Changes	385
8.7.5.2	Reset Controller While the Drive is Running	386
8.7.6	SD Card Support	387
8.7.6.1	Supported SD Card Formats	387
8.7.7	Controller Backup and Restore	387
8.7.7.1	Backup	387
8.7.7.2	Restore	388
8.7.7.3	Data Transfer	388
8.7.7.4	B3 Button Backup	389
8.7.7.5	B3 Button Restore	389
8.7.8	Backup and Restore tab	390
8.7.8.1	EtherCAT Devices Backup	391
8.7.8.1.1	Required Items	391
8.7.8.1.2	Device Connection and Configuration	391
8.7.8.1.3	Modular EtherCAT	391
8.7.8.1.4	Backup Procedure	391
8.7.8.2	EtherCAT Devices Restore	392
8.7.8.2.1.1	Procedure	393
8.7.8.3	AKD or AKD2G Backup / Restore Compatibility	393

8.7.8.4	Controller Import / Export Backup from Web server	395
8.7.8.4.1	Controller Backup Import / Export	395
8.7.8.4.2	EtherCAT Devices Backup Import / Export	395
8.7.8.4.3	Export Procedure	396
8.7.8.4.4	Import Procedure	396
8.7.8.5	EtherCAT Devices Backup / Restore Limitations	396
8.7.8.5.1	Backup Conditions	397
8.7.8.6	EtherCAT Devices Backup / Restore Troubleshooting	397
8.8	Controller Onboard I/O	398
8.9	Using SSH	400
8.9.1	Login	400
8.9.2	SSH Login to a Controller	400
8.9.2.1	Login to AKD PDMM and PCMM	400
8.9.2.2	Login to PCMM2G	400
8.9.2.2.1	List of Common SSH Clients	401
8.9.3	Change Controller's Password using SSH	401
8.9.3.1	AKD PDMM and PCMM: Change Password	401
8.9.3.2	PCMM2G: Change Password	401
8.9.4	Restore Controller Default Password	402
8.9.4.1	Restore to Factory Settings	402
8.9.4.2	Restore AKD PDMM and PCMM	402
8.9.4.2.1	Restore using SSH	402
8.9.4.3	Restore PCMM2G	402
8.9.5	Using the KAS Web server	402
8.9.5.1	Access the Web server	403
8.9.5.1.1	Web Browser Access	403
8.9.5.1.2	Controller B3 Access	403
8.9.5.1.3	Links	403
8.9.5.1.4	Tabs	403
8.9.6	Home tab	404
8.9.6.1	Security	405
8.9.6.1.1	Backup and Restore	405
8.9.6.1.2	Diagnostics tab	405
8.9.6.1.3	KAS Application tab	405
8.9.6.1.4	Settings tab	405
8.9.6.1.5.1	PCMM2G Only	405
8.9.6.1.6	Timeout after Inactivity	406
8.9.6.2	User Authentication	406
8.9.6.2.1	Login In	406
8.9.6.2.2	Logging Out	407
8.9.6.2.3	Changing the Password	407
8.9.7	KAS Application tab	408
8.9.7.1	Axis tab	408
8.9.7.2	Log Configuration tab	409
8.9.7.2.1	Source	410
8.9.7.2.2	Level	410
8.9.7.3	Log Data tab	410
8.9.7.3.1.1	AKD PDMM and PCMM	412

8.9.7.3.2.2 PCMM2G Only	412
8.9.7.3.3 Log Message Content	412
8.9.7.3.4 Controller Log Files	412
8.9.7.3.5.1 Log File Naming Convention	412
8.9.7.3.6.2 Error and Alarm History File (PCMM2G only)	413
8.9.7.4 User Data tab	413
8.9.7.5 Shared Directory tab	414
8.9.7.5.1 Field Descriptions	414
8.9.8 Settings tab	415
8.9.8.1 Date/Time tab	417
8.9.8.1.1 Date/Time and NTP Status	418
8.9.8.1.2 Update Date/Time	419
8.9.8.1.3 Network Time Protocol (NTP)	420
8.9.8.1.4.1 Correct an A05 Alarm	420
8.9.8.1.5 Set Time Zone	421
8.9.8.2 File System tab	421
8.9.8.2.1 Reset the Controller to Factory Settings	421
8.9.8.2.2.1 Factory Reset Changes	421
8.9.8.3 Firmware tab	422
8.9.8.3.1 Upgrade the Controller's Firmware	423
8.9.8.3.2 View Firmware Information	427
8.9.8.3.3.1 File Types	428
8.9.8.3.4 Recover Using the Web server	428
8.9.8.3.5.1 AKD PDMM and PCMM Web server Recovery	428
8.9.8.3.6.2 PCMM2G Web server Recovery	429
8.9.9 Recovery USB Flash Drive	429
8.9.10 Production Image Recovery Procedure	429
8.9.11 Customer Image Recovery	430
8.9.11.1 Network tab	431
8.9.11.1.1 Rotary Switch	431
8.9.11.1.2 Manually Change the IP Address	431
8.9.11.2 SD Card tab	432
8.9.11.2.1 SD Card Actions	432
8.9.11.3 USB Flash Drive tab	432
8.9.11.4 Change the Web server's User Account Password	433
8.9.11.4.1 I Forgot My Password	434
8.9.12 Backup and Restore from the Web server	434
8.9.12.1 All Controllers	434
8.9.12.2 PCMM2G Backup / Restore Only	434
8.9.12.3 Backup tab	435
8.9.12.3.1 AKD PDMM or PCMM Controller Backup	435
8.9.12.3.2 PCMM2G Controller and EtherCAT Devices Backup	436
8.9.12.3.3.1 PCMM2G Backup / Restore Only	436
8.9.12.3.4 EtherCAT Devices Backup	438
8.9.12.3.5.1 Scenario 1 - Archived Firmware Copy = Firmware used on Drives	438
8.9.12.3.6.2 Scenario 2 - Archived Firmware Copy Not = Network Configuration	438
8.9.12.3.7.3 Scenario 3 - Only Unique ID Backed Up	438
8.9.12.4 Restore tab	439

8.9.12.4.1	Restore Controller	439
8.9.12.4.2	PCMM2G Backup / Restore Only	439
8.9.12.4.3	Restore EtherCAT Devices	439
8.9.12.4.4	Advanced	439
8.9.12.5	Import / Export tab	440
8.9.12.5.1	Controller	440
8.9.12.5.2	EtherCAT Devices	440
8.9.13	Diagnostic tab	440
8.9.13.1	Errors and Alarms	441
8.9.13.2	Hardware Status	442
8.9.13.3	Crash Reports	442
8.9.13.4	EtherCAT Diagnostics tab	442
9	Tools	444
9.1	Cam Profile Editor	444
9.1.1	Windows Overview	444
9.1.2	CAM Profile Editor's CAM Table	445
9.1.2.1	Cam Editor - Table Parameters	445
9.1.2.2	Cyclic Cam Element	446
9.1.2.3	Modifying an Element using the Cam Table	446
9.1.2.4	Modifying the Type of a Cam Element	447
9.1.2.5	Cam Table Contextual Menu	447
9.1.2.6	Add a Point to the Cam Table	448
9.1.2.7	Remove a Point from the Cam Table	449
9.1.3	Cam Profile Graph	449
9.1.3.1	Modifying an Element	449
9.1.3.2	Cam Profile Graph Contextual Menu	450
9.1.3.3	Zoom In and Out	450
9.1.3.4	Panning	450
9.1.3.5	Restoring Zoom and Pan	451
9.1.4	Cam Profile Segment Overview	451
9.1.4.1	Line Segment Type	451
9.1.4.2	Parabolic Segment Type	451
9.1.4.3	Point Segment Type	452
9.1.4.4	Spline Segment Type	452
9.1.5	Curve Selection and Color Table	453
9.1.5.1	How to change color	453
9.1.5.2	Curves Graph	454
9.1.6	Reload, Save, Auto Fit, and Properties Buttons	455
9.1.7	Import a CAM Profile	455
9.1.7.1	The Import	456
9.1.7.2	Displaying the Imported CAMProfile	456
9.1.7.3	Invalid Data	457
9.2	Custom Input/Output Editor	457
9.2.1	Add Input/Output	457
9.2.2	Delete Input/Output	457
9.2.3	Modify Input/Output	457
9.3	Human-Machine Interface Editor	458
9.3.1	Using Kollmorgen Visualization Builder	458

9.3.1.1	Create A New KVB Controller	459
9.3.1.2	Import Variables Into The Project	461
9.3.1.3	Design the HMI Panel with KVB	463
9.3.1.3.1	Add Object	463
9.3.1.3.2	Customize Object	463
9.3.1.3.3	Map Variable to the Object	464
9.3.1.4	Download the KVB Panel	464
9.3.2	Design the HMI with the Internal Editor	464
9.3.2.1	Create Control Panel	464
9.3.2.2	Use the Control Panel Control Library	464
9.3.2.3	Edit the Control panel	465
9.3.2.3.1	HMI Grid Settings	465
9.3.2.4	Map Variables to the Control Panel	466
9.3.2.5	Graphic Objects	467
9.3.2.5.1	Basic Shapes	467
9.3.2.5.2	Bitmaps	468
9.3.2.5.3	Scales	468
9.3.2.5.4	Text boxes	469
9.3.2.5.5	Switches and 2-state displays	469
9.3.2.5.6	Analog buttons	470
9.3.2.5.7	Bar Graphs	470
9.3.2.5.8	Charts	471
9.3.2.5.9	Analog meters	471
9.3.2.5.10	Digital meters	472
9.3.2.5.11	Links	473
9.3.2.5.12	Connection status	473
9.3.2.5.13	Gauges	473
9.3.2.6	Graphic Objects Properties	474
9.3.2.7	Operate the Control Panel	479
9.3.2.7.1	KAS Simulator Display	480
9.3.2.7.2	Exiting Simulation Mode	480
9.4	Pipe Network Editor	480
9.4.1	Inserting Pipe Blocks or Comments	481
9.4.2	Inserting Connections	481
9.4.3	Connect a Comment to a Pipe Block	482
9.4.4	Pipe Network Editor Controls	482
9.4.5	Plug/Unplug Channels	484
9.5	Soft Oscilloscope	484
9.5.0.1	Control Panel	484
9.5.0.2	Graphical Area	485
9.5.1	Access the Soft Oscilloscope	485
9.5.2	About OpenGL	485
9.5.3	Oscilloscope Control Panel	486
9.5.4	Oscilloscope Graphical Area	491
9.5.5	Traces	491
9.5.6	Plugging Probes, Mapping Variables	492
9.5.6.1	Mapping a Variable to the Oscilloscope	492
9.5.6.1.1	Un-map Variables from the Scope	493

9.5.6.2	Plug a Probe from the Dictionary	494
9.5.6.3	Plugging a probe from the Pipe Network	495
9.5.7	Setting Scale	496
9.5.7.1	Time Scale	496
9.5.7.2	Variable Scale	496
9.5.8	Trace Zoom Feature	497
9.5.9	How Do I Export the Oscilloscope Data?	497
9.5.10	Practical Application: Using Trace Time To Measure CPU Load	499
9.5.10.0.1	AKD PDMM / PCMM	499
9.5.10.0.2	PCMM2G	500
9.5.10.1	Oscilloscope Trace Times	500
9.5.10.1.1	Press the Start Button to Collect Some Data	501
9.5.10.2	Check the Peak Times	502
9.5.10.2.1	RealTimeMargin or PLCMargin Time	502
9.5.10.2.2	CycleJitter Trace	503
9.5.10.3	Example: AKD PDMM and PCMM Heavily Loaded CPU	504
9.5.10.3.1	1. MotionExec and PLCProgExec Times	504
9.5.10.3.2	2. PLCProgExec Peaks	504
9.5.10.3.3	3. RealTimeMargin	505
9.5.10.3.4	4. Controller Log	505
9.5.10.3.5	5. CPU Load	505
9.5.10.4	Example: AKD PDMM and PCMM Over Loaded CPU	506
9.5.10.4.1	1. MotionExec and PLCProgExec Times	506
9.5.10.4.2	2. RealTimeMargin	507
9.5.10.4.3	3. Controller Log	507
9.5.10.4.4	4. CPU Load	507
9.5.10.5	Example: PCMM2G Heavily Loaded CPU	508
9.5.10.5.1	1. MotionExec and PLCProgExec Times	508
9.5.10.5.2	2. PLCProgExec Peaks	509
9.5.10.5.3	3. PLCMarginTime	509
9.5.10.5.4	4. Controller Log	510
9.5.10.6	Example: PCMM2G Over Loaded CPU	510
9.5.10.6.1	1. MotionExec and PLCProgExec Times	511
9.5.10.6.2	2. RealTimeMargin	511
9.5.10.6.3	3. Controller Log	512
10	Advanced Topics	514
10.1	Coordinated Motion	514
10.1.1	Group State Diagrams	514
10.1.2	Coordinate Systems	514
10.1.3	Design Coordinated Motion	515
10.1.3.1	Blending Between Moves	516
10.1.3.2	Blending with Transitions	517
10.1.3.3	Create a Linear or Circular Coordinated Motion Application	518
10.1.3.3.1.1	Groups	518
10.1.3.3.2	Function Block Calls	518
10.1.3.3.3	What are Axes Groups?	521
10.1.3.3.4	Perform a Circular Move	521
10.1.3.3.5.1	Absolute Circular Move	521

10.1.3.3.6.2	Relative Circular Move	522
10.1.3.3.7.3	Circular Moves Diagrams	523
10.2	CircMode = BORDER	523
10.3	CircMode = CENTER	523
10.3.0.0.1.1	Precision Requirements for Circular Move Input Parameters	524
10.4	Parameter Validation	524
10.5	Default Validation Method	524
10.6	Validation with Custom Tolerance	525
10.6.0.0.1.1	Perform a Complete Circular Move	525
10.6.0.0.2	Perform a Linear Move	525
10.6.0.0.3.1	Absolute Linear Move	526
10.6.0.0.4.2	Relative Linear Move	526
10.6.0.0.5.3	Linear Move With More Than Two Axes	527
10.6.0.1	Differences between MC_GrpHalt and MC_GrpStop	527
10.6.0.1.1	What MC_GrpHalt Does	528
10.6.1	Exceptions	529
10.6.1.0.1	What MC_GrpStop Does	530
10.6.2	Exceptions	532
10.6.2.1	Handling Axis Errors	533
10.6.2.1.1	Optional Behavior	533
10.6.2.1.2	Default and Optional Error Handling Behavior	533
10.6.2.1.3.1	Default Error Handling Behavior	533
10.6.2.1.4.2	Optional Error Handling Behavior	533
10.6.2.1.5	Recovery of the System State After an Axis Error	534
10.6.2.2	Transition Between Moves	535
10.6.2.2.1.1	Transition Mode Parameters	535
10.6.2.2.2	No Transition (TM_NONE)	535
10.6.2.2.3	Corner Distance (TM_CORNER_DISTANCE)	535
10.6.2.2.4.1	Transition Parameter Index	536
10.6.2.2.5	S-Curve Corner (TM_SCURVE_CORNER)	536
10.6.2.2.6.1	Transition Parameter Index	536
10.6.2.2.7	Arc-to-Arc Transitions	537
10.6.2.2.8.1	Intersection Transition	537
10.6.2.2.9.2	Line Segment Transition	538
10.6.2.2.10.3	Same Circle: Opposite Direction Transition	538
10.6.3	n-Degree: Arcs in Opposite Direction	538
10.6.3.0.1.1	Same Circle: Same Direction Transition	539
10.6.4	n-Degree: Arcs in Same Direction	539
10.6.4.0.1.1	Tangent Transition: Opposite Direction	539
10.6.4.0.2.2	Zero-distance Transition	540
10.6.4.0.3	Line-to-Arc and Arc-to-Line Transitions	540
10.6.5	n-Degree Transition	540
10.6.5.0.1.1	Special Case Transitions	540
10.6.6	Intersection Transition	541
10.6.7	Tangent Transition	541
10.6.8	Zero-distance Transition	541
10.6.8.0.1	Line-to-Line Transitions	542
10.6.8.0.2.1	n-Degree: Transition	542

10.6.8.0.3.2 Special Case Transitions	542
10.6.9 180-degree Transition	542
10.6.10 Zero-degree Transition	543
10.6.11 Zero-distance Transition	543
10.6.11.0.1 S-Curve Corner Line-to-Line Transitions	543
10.6.11.0.2.1 n-Degree: Transition	543
10.6.11.0.3.2 Special Case Transitions	544
10.6.12 180-degree Transition	544
10.6.13 Zero-degree Transition	544
10.6.14 Zero-distance Transition	545
10.7 Motion Techniques	545
10.7.1 Create a Digitizing Axis	545
10.7.1.1 Create a Digitizing Axis From Code	546
10.7.1.2 Create a Digitizing Axis When Using an Imported ENI File	546
10.7.1.3 Create a Digitizing Axis When EtherCAT Devices Are Defined	547
10.7.1.4 Create a Digitizing Axis When EtherCAT Devices Are Not Connected	548
10.7.1.5 Digitizing Axis - PLCopen Setup	549
10.7.1.6 Digitizing Axis - Encoders without a Z-Channel	551
10.7.2 Error Management	551
10.7.2.1 Axis Procedures	551
10.7.2.2 Machine Procedures	551
10.7.3 Fast Inputs	552
10.7.3.1 Fast Inputs with Pipe Network Motion	552
10.7.3.2 Fast Inputs with PLCopen Motion	553
10.7.4 Interpret a Timestamp	553
10.7.5 Overtravel Conditions	553
10.7.5.0.1 Configuring Generation 1 AKD Drives	554
10.7.5.1 Coordinated Motion Behavior	554
10.7.5.2 Pipe Network Behavior	554
10.7.5.3 PLCopen Behavior	554
10.7.6 PLC Online Change	555
10.7.6.1 What is Online Change	555
10.7.6.2 Activate an Online Change	557
10.7.6.2.1 Set the Parameters	557
10.7.6.2.2 Switch to Edit Mode	558
10.7.6.2.3 Dictionary Behavior	558
10.7.6.3 The Revert Button	558
10.7.6.4 Difference between Local and Controller Versions	559
10.7.6.5 Pulse Limitations with Online Change	559
10.7.6.6 Using PLC Online Change	560
10.7.6.6.1 Set up an Application	560
10.7.6.6.2 Enable Online Change	560
10.7.6.6.3 Using Online Change	560
10.7.6.6.4 Revert Online Change	561
10.7.7 PLCopen Homing	561
10.7.7.1 PLCopen Homing Description	561
10.7.7.2 PLCopen Homing Methods	562
10.7.7.2.1 Home using Current Position	562

10.7.7.2.2 Find Input	562
10.7.7.2.3 Find Input then find Zero Angle	563
10.7.7.2.4 Find Input then find Index	563
10.7.7.2.5 Find Index	563
10.7.7.3 AKD Capture Engine Configuration	563
10.7.7.3.1 AKD Configuration Parameters	564
10.7.8 Pipe Network Homing	565
10.7.8.1 Fast Homing Example with the Pipe Network Motion Engine Axis Pipe Block	565
10.7.9 PLCopen Registration	566
10.7.9.1 Decide which Function Blocks to Use for Registration	567
10.7.9.2 Master/Slave Registration	569
10.7.9.2.1 Master Registration	569
10.7.9.2.2 Slave Registration	569
10.7.9.3 Single-Axis Registration	570
10.7.9.4 Registration Application Guide	570
10.7.9.4.1 Mark to Mark Registration	571
10.7.9.4.2 Mark to Machine Registration	571
10.7.9.5 Fast Homing Example with the PLCopen Motion Engine	571
10.7.10 Pipe Network Registration and Fast Homing	572
10.7.10.1 Fast Homing Example with the Pipe Network Motion Engine Axis Pipe Block	572
10.7.10.2 Registration Position Capture Example with Pipe Network Trigger Block	574
10.7.11 Practical Applications - Camming	575
10.7.11.1 Cam On The Fly	575
10.7.11.2 Positioning an Axis Before Starting Camming	576
10.7.11.3 Resume Camming After an E-Stop	576
10.7.12 Restarting Motion with Pipe Network	576
10.7.13 Superimposed Axes with PLCopen	577
10.7.14 Torque Feed-forward	577
10.7.15 Tuning Controller Performance for EtherCAT Communication Latency	578
10.8 Motion Bus and Fieldbuses	579
10.8.1 EtherCAT	579
10.8.2 EtherNet/IP	579
10.8.3 Modbus and TCP/IP	579
10.8.4 PROFINET	579
10.8.5 I/O Mapping (for Profibus Fieldbus)	580
10.8.6 Add an Unsupported EtherCAT Device	581
10.8.6.1 Modify the EtherCAT Image in Cyclic Mode	581
10.8.6.2 Configure the EtherCAT Device	581
10.8.6.3 Map PLC Variables	582
10.8.6.3.1 Examples	582
10.8.7 Set Up FSoE Master and an AKD2G with SafeMotion Monitor	582
10.8.7.1 Create Safety Application	583
10.8.7.2 KAS-IDE Project Set Up	583
10.8.8 AKD2G Safety Parametrization Using FSoE with SCU-1-EC and PxMM / PCMM2G	584
10.8.8.1 Requirements	584
10.8.8.2 Procedure	584
10.8.9 Fieldbus Editor	585
10.8.9.1 EtherNet/IP Controller Data Communications	585

10.8.9.2 EtherNet/IP Controller EDS File	585
10.8.9.2.1 Using EDS Files	586
10.8.9.3 EtherNet/IP Adapter (Server)	587
10.8.9.3.1 Data Exchange - Configuration	587
10.8.9.3.2 Configuration	587
10.8.9.4 EtherNet/IP FlexIO / PointIO	588
10.8.9.5 EtherNet/IP IO Scanner (Client)	589
10.8.9.5.1 Data Exchange Configuration	589
10.8.9.5.2 Server Configuration	590
10.8.9.5.3 Edit the Configuration Data Block	590
10.8.9.5.4 Assembly Configuration	591
10.8.9.5.5 Configuring Variables	592
10.8.9.6 EtherNet/IP Tag Client	592
10.8.9.6.1 Data exchange - Configuration	592
10.8.9.6.2 Configuration	592
10.8.9.7 Modbus Slave	594
10.8.9.7.1 Protocol Specification	594
10.8.9.7.2 Data Exchange Configuration	595
10.8.9.7.3 Modbus Slave Configuration	595
10.8.9.7.4 Data Types	597
10.8.9.8 PROFINET Configuration	597
10.8.9.8.1 Configure a PROFINET IO Controller	597
10.8.9.8.2 Configure a PROFINET IO Device	602
10.8.9.8.3 PROFINET - Additional Features	607
10.8.9.8.4.1 All PROFINET Equipment	607
10.8.10 Create IOxS for Slave Modules	607
10.8.10.1 Input Modules or Modules without IO Data	607
10.8.10.2 Output Modules	608
10.8.11 Create Variables	608
10.8.12 Device Diagnosis	608
10.8.12.0.1.1 PROFINET Controllers Only	608
10.8.13 Browse Network for Slaves	608
10.8.14 Device Configuration	609
10.8.15 Read Module Configuration	609
10.8.16 Set Slave Station Name	609
10.8.16.0.1 PROFINET - Data Types	609
10.8.16.0.2 PROFINET - Error and Status Codes	609
10.8.16.0.3.1 Error Codes and Meanings	609
10.8.16.0.4.2 PNIO Status Codes - Negative Responses	610
10.8.16.0.5.3 Error Code - Negative Responses	610
10.8.16.0.6.4 Error Decode - Negative Responses	610
10.8.16.0.7.5 Error Code 1 for Error Decode = 80	610
10.8.16.0.8.6 Error Code 1 for Error Decode = 81	611
10.8.16.0.9.7 Error Code 2 for Error Code 1 = 40	612
10.8.16.0.10.8 Error Code 2 for Error Code 1 <> 40	612
10.8.16.0.11.9 Error Code 2 for Error Code 1 = 01	612
10.8.16.0.12.10 Error Code 2 for Error Code 1 = 02	613
10.8.16.0.13.11 Error Code 2 for Error Code 1 = 03	614

10.8.16.0.14.12	Error Code 2 for Error Code 1 = 04	614
10.8.16.0.15.13	Error Code 2 for Error Code 1 = 8	614
10.8.16.0.16.14	Error Code 2 for Error Code 1 = 16	615
10.8.16.0.17	PROFINET - Resolve Errors	615
10.8.16.0.18.1	Additional Analyses - Controllers Only	615
10.8.16.0.19.2	CL-RPC Lookup - Devices Only	615
10.8.17	Timeout Error	615
10.8.17.0.1.1	Connect Response Error	616
10.8.18	Timeout Error	616
10.8.18.0.1.1	Device is not Found	616
10.8.18.0.2.2	Error Setting the IP Configuration	616
10.8.18.0.3.3	Module Configuration is Different	616
10.8.18.0.4.4	Other Errors	616
10.8.18.0.5.5	Writing Parameterization Error (with status 0xDF80*)	617
10.8.19	Use Wireshark	617
10.8.20	Modular EtherCAT Concept	617
10.8.20.1	Introduction	617
10.8.20.2	Examples of Modular Machine Design Uses	617
10.8.20.2.1	Machine with Multiple Variants	617
10.8.20.2.2	Module Maintenance	618
10.8.20.2.3	Share Modules across Machines in a Factory Line	618
10.8.20.3	Modular Design Guidelines	618
10.8.20.4	Backing up Modular EtherCAT Devices	618
10.8.20.5	Limitations	618
10.8.20.6	Create an Application with Modular EtherCAT	619
10.8.20.6.1	Create a Machine Variant with the Basic Machine	620
10.8.20.6.2	ST Language Example	620
10.8.20.6.3	Add a Module	621
10.8.20.6.4	ST Language Example	621
10.8.20.6.5	Remove a Module	621
10.8.20.6.6	ST Language Example	621
10.8.21	Controller Performance Guidelines	622
10.8.21.1	AKD PDMM and PCMM - 800MHz	623
10.8.21.2	AKD PDMM and PCMM - 1.2GHz	623
10.8.21.3	PCMM2G	623
10.8.21.4	Example: EtherNet/IP Performance	623
10.9	Project Structure Guidelines	623
10.9.1	External Files	624
10.9.2	Application Software Structure - Definitions	624
10.9.2.1	Modules to Build up the Structure	624
10.9.2.1.1	Structure Overview	624
10.9.2.1.2	Main Module	625
10.9.2.1.3.1	Module Controller	626
10.9.2.1.4.2	Functional Part	626
10.9.2.1.5	Axis Module	626
10.9.2.1.6.1	Axis Module Controller	626
10.9.2.2	State and Function Definitions	626
10.9.2.2.1	State, State Transitions and Functions	627

10.9.3 Application Software Structure - Implementation	627
10.9.3.1 SFC Children Building up the Software	627
10.9.3.1.1 Parent SFC	627
10.9.3.1.2 Main Module SFC Children	628
10.9.3.1.3 Axis Module SFC Children	628
10.9.3.2 Functions Linked to States	628
10.9.3.2.1 Functions Treatment	628
10.9.3.2.2.1 Function (Function Step)	628
10.9.3.2.3 Add a New Function	629
10.9.3.3 Main Module Implementation	629
10.9.3.3.1 bErrorReset	630
10.9.3.3.2 M1_AckState	630
10.9.3.3.3 M1_CmdState	630
10.9.3.3.4 M1_ErrorHandling	630
10.9.3.3.5 M1_ModStatus, (Ai_ModStatus)	631
10.9.3.3.6 M1_ModuleController	631
10.9.3.3.7.1 M1_ReqState	632
10.9.3.4 States and Errors	632
10.9.3.4.1 States and Errors Treatment	632
10.9.3.4.2 Add a New State	633
10.9.3.5 Variables for the Interface	633
10.9.3.5.1 List of Variables	633
10.9.3.5.2 List of Output Variables	633
10.10 Project Templates	634
10.10.1 Coordinated Motion	634
10.10.2 KAS Runtime	634
10.10.3 KDN Download	634
10.10.4 Pipe Network	634
10.10.5 PLCopen	635
10.10.6 Template Inclusions	635
10.10.7 Coordinated Motion	636
10.10.7.1 Coordinated Motion - 2-Axis Template	636
10.10.7.1.1 Programs	636
10.10.7.1.2 Motion Procedure	636
10.10.7.1.3 Control Panel	636
10.10.7.2 Coordinated Motion - 3-Axis Template	637
10.10.7.2.1 PLC Programs	637
10.10.7.2.2 Motion Procedure	637
10.10.7.2.3 Control Panel	638
10.10.7.3 Coordinated Motion - 3-Axis (3D) Template	638
10.10.7.3.1 PLC Programs	639
10.10.7.3.2 Motion Pattern Procedure	639
10.10.7.3.3 Control Panel	639
10.10.8 Pipe Network Axis Templates	640
10.10.8.1 Pipe Network 1-Axis Template - FFLD	641
10.10.8.2 Pipe Network 1-Axis Template - ST	641
10.10.8.3 Pipe Network 2-Axes Template - FBD, FFLD, SFC, and ST	642
10.10.8.3.1 Control Panel	642

10.10.8.3.2 HMI	643
10.10.8.3.3 Motion	644
10.10.8.3.4 PLC Programs	644
10.10.8.4 Pipe Network 2-Axes Template - ST	647
10.10.8.4.1 Control Panel	647
10.10.8.4.2 HMI	648
10.10.8.4.3 Motion	649
10.10.8.4.4 PLC Programs	649
10.10.8.5 Pipe Network 2-Axes Template - FFLD	650
10.10.8.5.1 Control Panel	650
10.10.8.5.2 HMI	651
10.10.8.5.3 Motion	652
10.10.8.5.4 PLC Programs	652
10.10.9 PLCopen Axis Templates	653
10.10.9.1 PLCopen 1-Axis Template - FFLD	653
10.10.9.2 PLCopen 1-Axis Template - ST	654
10.10.9.3 PLCopen 2-Axes Template - FFLD and SFC	655
10.10.9.3.1 PLC Programs	655
10.10.9.3.2.1 Control Panel Screens	657
10.10.9.3.3.2 Control Panel Sections	657
10.10.9.4 PLCopen 2-Axes Template - ST	659
10.10.9.4.1 PLC Programs	660
10.10.9.4.2.1 Control Panel Screens	660
10.10.9.4.3.2 Control Panel Sections	660
10.10.9.5 PLCopen 2-Axes Template - FFLD	663
10.10.9.5.1 Control Panel	664
10.10.9.5.2.1 Control Panel Screens	664
10.10.9.5.3.2 Control Panel Sections	664
10.10.9.5.4 HMI	665
10.10.9.5.5 Motion	666
10.10.9.5.6 PLC Programs	667
11 Controller Error and Alarm Descriptions	668
11.1 Errors	668
11.2 Alarms	680
11.3 Actual Position Interpolation	682
11.4 CPU Overload (E23)	682
12 KAS Component Manuals	685
12.1 BBH FSoE Master	685
12.2 Controllers	685
12.2.1 Controller Differences	686
12.2.1.1 Hardware Differences	686
12.2.1.2 Software Differences	687
12.2.2 AKD PDMM Specifications	687
12.2.2.1 AKD PDMM Specifications	687
12.2.2.2 AKD-Mxxx Model Specifications	688
12.2.3 PCMM Specifications	688
12.2.4 PCMM2G Specifications	689
12.2.5 Part Number Scheme	690

12.2.6 NVRAM	691
12.2.6.1 NVRAM Life Expectancy	691
12.2.6.1.1 Verify the NVRAM Space	691
12.3 Drives	692
12.3.1 Related Documents	692
12.3.2 AKD-M Kx PDMM Controller / Drive Variant	693
12.3.2.1 FAQs for the Kx Controller / Drive	693
12.3.3 AKD-N "ES" Drive Variant	694
12.3.3.1 FAQs for the "ES" Drive	694
12.3.4 AKD-P "NC" Drive Variant	694
12.3.4.1 FAQs for the "NC" Drive	694
12.3.5 AKD-P "ND" Drive Variant	695
12.3.5.1 FAQs for the "ND" Drive	695
12.3.6 MKD-C "ND" Central Power Supply Variant	696
12.3.6.1 FAQs for the "ND" Central Power Supply	696
12.4 HMI	696
12.4.1 HMI Accessories	697
12.5 Remote Input/Output Terminals	697
12.6 Safety Solutions	700
12.6.1 KSM-compact Safety Module	700
12.6.2 KSM-modular Safety PLC	700
12.6.3 Safety Functions (PLe & SIL3)	701
12.6.4 Connectivity	701
12.7 Understanding KAS	702
12.7.1 IEC 61131-3	702
12.7.1.1 Data Types	702
12.7.1.1.1 Different Data Types	702
12.7.1.1.2 List of Data Types	702
12.7.1.1.3 Structure	703
12.7.1.1.4.1 Limitation	703
12.7.1.1.5 Arrays	703
12.7.1.2 Variables	704
12.7.1.2.1 Retain Variables	704
12.7.1.2.2 Variables	705
12.7.1.2.3.1 Groups	705
12.7.1.2.4.2 Data Type and Dimension	706
12.7.1.2.5.3 Name a Variable	706
12.7.1.2.6.4 Variable Attributes	706
12.7.1.2.7 Retain Variables	707
12.7.1.2.8.1 What is a retain variable?	707
12.7.1.2.9.2 Copy a Retained Variable Value to Init Value	708
12.7.2 Limitations	709
12.7.2.1 Constant Expressions	710
12.7.2.1.1 Examples	713
12.7.2.1.2.1 Valid Constant Expressions	713
12.7.2.1.3.2 Invalid Constant Expressions	714
12.7.2.2 Program Organization Units	714
12.7.2.2.1 Differences between Functions and Function Blocks	714

12.7.2.2.2.1	Description of FB Operation	714
12.7.2.2.3.2	Examples of Operations Overrunning the Cycle Duration	714
12.7.2.2.4.3	Operation Sequence	714
12.7.2.2.5	Functions	714
12.7.2.2.6	Function Blocks	715
12.7.2.2.7	Programs	716
12.7.2.2.8.1	Sub-programs	716
12.7.2.2.9.2	Program Guidelines	716
12.7.3	Program Name	717
12.7.4	Child SFC Programs	717
12.7.4.0.1.1	Program Limitations	717
12.7.4.0.2	User-Defined Function Blocks	717
12.7.4.1	Programming Languages	718
12.7.4.1.1	Sequential Function Chart	718
12.7.4.1.2.1	Alternative and Parallel Sequences	719
12.7.4.1.3	Structured Text	719
12.7.4.1.4	Function Block Diagram	719
12.7.4.1.5	Free Form Ladder Diagram	719
12.7.4.1.6	Instruction List	719
12.7.4.2	Alias Definitions	719
12.7.4.2.1	Example	720
12.7.4.3	Exception Handling	721
12.7.4.3.1	Division By Zero Exceptions	721
12.7.4.3.2	Shutdown Exceptions	721
12.7.4.3.3	Startup Exceptions	722
12.7.5	Motion Concepts	722
12.7.5.1	Introducing Motion	722
12.7.5.1.1	Motion Control Main Functions	722
12.7.5.1.2.1	Setpoint Generation	722
12.7.5.1.3.2	Regulation	722
12.7.5.1.4	Single and Multi-Axis Motion	723
12.7.5.1.5	Hardware Organization of Motion Functions	723
12.7.5.1.6	Motion Profile	724
12.7.5.1.7	KAS Touch Probe and Fast Input Overview	724
12.7.5.1.8.1	Configuration	724
12.7.6	Drive Configuration	724
12.7.7	Pipe Network Configuration	724
12.7.8	PLCopen Configuration	725
12.7.8.0.1.1	List of Function Blocks and Pipe Blocks	725
12.7.9	PLCopen Function Blocks	725
12.7.10	Pipe Network Blocks	725
12.7.10.1	Pipe Network or PLCopen	725
12.7.10.1.1	Pipe Network	725
12.7.10.1.2	PLCopen	726
12.7.10.1.3	Pipe Network and PLCopen Motion Engine Differences	726
12.7.10.2	Pipe Network Concept	727
12.7.10.2.1	Pipe Network	728
12.7.10.2.2	Pipe Structure	728

12.7.10.2.3	Pipe Block	729
12.7.10.2.4.1	Pipe Network - List of Pipe Blocks	729
12.7.10.2.5.2	Change the Information Flow from Position to Velocity	732
12.7.10.2.6	Axis Pipe Block	733
12.7.10.2.7.1	Associated Data on Positions	733
12.7.10.2.8.2	Axis Block Initialization	734
12.7.10.2.9.3	Axis Connection to a Pipe	735
12.7.10.2.10.4	Change Axis Position Functions	735
12.7.10.2.11.5	Homing	735
12.7.10.2.12.6	Monitor an Axis	735
12.7.10.2.13.7	Multi-Axis Operation	736
12.7.10.2.14.8	Realign Positions	736
12.7.10.2.15.9	Set Zero Axis	736
12.7.10.2.16.10	Single-Axis Operation	736
12.7.10.2.17.11	Units	737
12.7.10.2.18.12	View Axis Block Position Functions	737
12.7.10.2.19	Executing Motion	737
12.7.10.2.20	Pipe Block Lifetime	738
12.7.10.2.21	Motion State Machine	738
12.7.10.2.22	Phase Execution in the Pipe Network	738
12.7.10.2.23.1	Absolute Phase of Execution	738
12.7.10.2.24.2	Relative Phase of Execution	738
12.7.10.2.25	Use Motion Function Block for Pipe Network	739
12.7.10.2.26.1	Buffer Mode	739
12.7.10.2.27.2	Motion Init	739
12.7.10.2.28.3	Motion Start	739
12.7.10.2.29.4	Using the Q Output of ML Function Blocks for the Pipe Network	739
12.7.10.2.30	Pipe Network - General Rules	740
12.7.10.2.31.1	Languages	740
12.7.10.2.32.2	BlockID Inputs	740
12.7.10.2.33.3	Output Status	740
12.7.10.2.34.4	What is the Difference between Q and OK?	740
12.7.10.2.35.5	When Q is Set to TRUE	741
12.7.10.2.36.6	Input Parameters	741
12.7.10.2.37.7	Missing Input Parameters	741
12.7.10.2.38.8	Position versus Distance	741
12.7.10.2.39.9	Default Block Parameters	741
12.7.10.2.40	Using the Generated Pipe Network Function	741
12.7.10.3	PLCopen®	743
12.7.10.3.1	PLCopen Function Blocks	743
12.7.10.3.2.1	PLCopen Function Block ErrorIDs	744
12.7.10.3.3.2	Axes Group Parameters	748
12.8	Boolean Parameters	748
12.9	Non-Boolean Parameters	748
12.9.0.0.1.1	Axis Parameters	749
12.10	Update Rate Types	749
12.10.1	Controller	749
12.10.2	EtherCAT Cyclic	749

12.10.3 EtherCAT Non-Cyclic	749
12.10.4 Static	749
12.11 User Units to Feedback Units Ratio	749
12.11.1 Example 1	749
12.11.2 Example 2	750
12.11.3 Example 3 - Reading the Current to Units of Amps	750
13 Boolean Parameters	751
13.0.1 Parameter Details	751
14 Non-Boolean Parameters	756
14.0.1 Parameter Details	756
14.0.1.0.1.1 Axis Positions Data	766
14.1 Actual Position	766
14.2 CommandPosition	766
14.2.1 CoordinatedMotionCmdPos	766
14.2.2 Group Actual Position	767
14.2.3 NormalCmdPos	767
14.2.4 PhaseCmd Pos	768
14.2.5 SuperimposedCmdPos	768
14.2.5.0.1.1 AXIS_REF Structure	768
14.2.5.0.2.2 Axis Velocity Data	768
14.3 Actual Velocity	768
14.4 Command Velocity	768
14.4.0.0.1.1 Buffer Modes	769
14.4.0.0.2.2 Move Types	770
14.4.0.0.3.3 Profile Generator	771
14.4.0.0.4.4 Queuing	771
14.4.0.0.5.5 S-curve and Trapezoidal Acceleration / Deceleration	771
14.5 S-curve	771
14.6 Small Jerk Acceleration	771
14.7 Large Jerk Acceleration	772
14.8 Trapezoidal	773
14.8.0.0.1.1 Function Block Acceleration and Jerk Parameters	774
14.9 Rules	774
14.10 Methods	774
14.10.1 Example 1	775
14.10.2 Example 2	775
14.10.3 Example 3	775
14.11 Limitations on Acceleration and Jerk	775
14.11.0.0.1.1 Velocity Compensation	776
14.12 Velocity Compensation Factor	776
14.13 Velocity Compensation Filter	777
14.13.0.0.1 Function Blocks - General Rules	777
14.13.0.0.2.1 Active Output	777
14.14 Coordinated Motion	777
14.14.0.0.1.1 Behavior of Busy Output	778
14.14.0.0.2.2 Behavior of CommandAborted Output	778
14.14.0.0.3.3 Behavior of Done Output	778
14.14.0.0.4.4 Error Handling Behavior	778

14.14.0.0.5.5	Input Parameters	778
14.15	PLCopen Function Blocks with Execute	779
14.16	PLCopen Function Blocks with Enable	779
14.17	PLCopen Functions with Input Parameter En	780
14.17.0.0.1.1	Inputs Exceed Application Limits	780
14.17.0.0.2.2	Missing Input Parameters	780
14.17.0.0.3.3	Output Exclusivity	780
14.17.0.0.4.4	Output Status	781
14.17.0.0.5.5	Sign Rules	781
14.17.0.0.6	PLCopen State Machine	781
14.17.1	State Machine for Multi-axes Motion Control	782
14.17.1.0.1.1	Disabled State	783
14.17.1.0.2.2	ErrorStop State	783
14.17.1.0.3.3	From StandStill to Stopping	783
14.17.1.0.4	Program a Multi-Core Controller	784
14.17.1.0.5.1	Cached Data	784
14.17.2	Function Blocks - Return Cached Data	784
14.17.2.0.1.1	Call Function Blocks Multiple Times in the Same Cycle	785
14.17.3	Function Blocks - Start Motion-related Actions	785
14.17.4	EtherCAT Motion Bus Concepts	786
14.17.4.1	EtherCAT Process Image	786
14.17.4.1.1	References	787
14.17.4.2	EtherCAT Functional Principle	787
14.17.4.3	EtherCAT Features	787
14.17.4.3.1	EtherCAT is Versatile	787
14.17.4.3.2	Safety over EtherCAT is Available	788
14.17.4.3.3	Device Profiles	788
14.17.4.3.4.1	CANopen over EtherCAT (CoE)	788
14.17.4.3.5	Distributed Clock (Synchronization)	789
14.17.4.3.6	File Access over EtherCAT (FoE)	790
14.17.4.3.7	Gateways	790
14.17.4.3.8	Performance	790
14.17.4.3.9	Protocol	791
14.17.4.3.10	Safety over EtherCAT	792
14.17.4.3.11	Topology	792
14.17.4.4	EtherCAT Implementation	793
14.17.4.4.1	Master Configuration	793
14.17.4.4.2.1	ESI and ENI Files	794
14.17.4.4.3	Slave Configuration	795
14.17.4.4.4.1	EtherCAT Slave Controller	796
14.17.4.4.5	EtherCAT State Machine	796
14.17.4.4.6.1	Different States	797
14.17.4.4.7	PDOs for AKD, AKD2G, AKD-N, S300, or S700	797
14.17.4.4.8.1	PDO Types	798
14.17.4.4.9.2	Examples	798
14.17.5	Example 1	798
14.17.6	Example 2	798
14.17.7	Example 3	798

14.17.7.0.1.1 From Controller to Drive (RxPDO)	798
15 RxPDO - AKD Drive CANopen Objects	800
16 RxPDO - AKD2G Drive CANopen Objects	801
17 RxPDO - AKD-N Drive CANopen Objects	803
18 RxPDO - S300 and S700 Drive CANopen Objects	804
18.0.0.0.1.1 From Drive to Controller (TxPDO)	804
19 TxPDO - AKD2G Drive CANopen Objects	805
20 TxPDO - AKD Drive CANopen Objects	807
21 TxPDO - AKD-N Drive CANopen Objects	810
22 TxPDO - S300 and S700 Drive CANopen Objects	811
22.0.0.1 CANopen	812
22.0.0.1.1 CANopen Status Machine	812
22.0.0.1.2.1 Status Description	813
22.0.0.1.3.2 Transitions of the Status Machine	813
22.0.1 Transition Events and Actions	813
22.0.1.0.1 CANopen Control Word	815
22.0.1.0.2.1 Bit Assignment in Control Word	815
22.0.1.0.3.2 Coded Commands	815
22.0.1.0.4 CANopen Status Word	816
22.0.1.0.5.1 Bit Assignment in Status Word	816
22.0.1.0.6.2 State Coding	816
22.0.2 AKD Drive	817
22.0.2.1 AKD Drive Configuration	817
22.0.2.1.1 Connection Modes	817
22.0.2.1.2.1 Disconnected	817
22.0.2.1.3.2 Online Configuration Mode	818
22.0.2.1.4.3 Project Running on the Controller	818
22.0.2.1.5 AKD Configuration According to EtherCAT State	818
22.0.3 Tasking Model / Scheduling	819
22.0.3.1 Priority Between Motion and PLC	820
22.0.3.1.1 EtherCAT Processing Time	820
22.0.3.1.2.1 Variation during the EtherCAT Processing	820
22.0.3.1.3 NVRAM Processing Time	821
22.0.3.1.4 Results when a PLC Program is Overrunning the Cycle Duration	821
22.0.3.2 Change the Priority Between PLC Programs	822
23 Troubleshooting	823
23.1 FAQs	823
23.1.1 Basic	823
23.1.2 Computer / Controller	826
23.1.3 EtherCAT	827
23.1.4 Performance	829
23.1.4.1 Resolution	830
23.1.5 Programming	831
23.1.5.1 Primary Feedback	831
23.1.6 Setup	833
23.1.6.1 Description	833
23.1.6.2 Firewall	834

23.1.6.3	Port Numbers	834
23.2	Compiler Errors	834
23.3	Compiler Warnings	838
23.3.0.1	10001 - Macro Redefinition	838
23.3.0.2	10002 - Not IEC Compliant	838
23.3.0.3	10003 - Same Name to a Global Variable and a Local Variable	838
23.3.0.4	10014 - Empty Line Ignored in Signal Resource (No Time Defined)	838
23.3.0.5	10015 - On Line Change may not be Possible: Too Many POUs or Variables	838
23.3.0.6	10019 - Definition of the Block was Changed	839
23.3.0.7	10020 - Backward Jump may Block the Target Cycle	839
23.3.0.8	10021 - FB Instance Missing (Unsafe)	839
23.3.0.9	10022 - Output Used Before it is Set. Execution may be Unsafe	839
23.3.0.10	10023 - Loop Instructions may Block the Target Cycle	839
23.3.0.11	10024 - Implicit Loops may be Unsafe	839
23.3.0.12	10025 - Input Parameters are not Considered as IN/OUT	840
23.3.0.13	10026 - Backward Jumps may Block the Cycle	840
23.3.0.14	10030 - Invalid PRINTF Format	840
23.3.0.15	10033 - LREAL# Prefix is Required to Avoid Loss of Accuracy	840
23.3.0.16	10034 - Loop Instructions may Block the Target Cycle	840
23.3.0.17	10037 - The Same Modbus Address is Used for Several Variables	840
23.4	Connect Remotely	840
23.5	CPU Load Reduction Techniques	841
23.6	EtherCAT Coupler Error Handling And Diagnosis	841
23.6.1	EtherCAT Diagnostic LEDs	841
23.6.2	EtherCAT LED Power Supply Diagnosis	842
23.6.3	EtherCAT LED Off Power Supply Diagnosis	842
23.6.4	LEDs for EtherCAT State Machine/PLC Diagnosis	842
23.6.5	LEDs for EtherCAT Connection Diagnosis	843
23.6.6	LEDs for EtherCAT Data Diagnosis	843
23.7	EtherCAT Diagnostics & Errors	845
23.7.1	EtherCAT Diagnostics	845
23.7.2	EtherCAT Error Messages	846
23.7.2.1	Other Messages Linked to EtherCAT	847
23.7.3	Example: EtherCAT Communication Diagnosis Steps	848
23.7.3.1	Diagnosing EtherCAT Communication Errors	848
23.7.3.1.1	Code Examples for Diagnosing EtherCAT Communication Errors	848
23.8	Re-import Kollmorgen UDFBs	849
23.9	Troubleshooting FSoE Safety Parameters	851
23.10	Troubleshooting KAS-IDE and SafePLC2	853
24	Appendices: Lists of Manuals, Content, and Support Information	857
24.1	AKD PDMM and PCMM - File Naming Conventions	857
24.1.1	File Contents	857
24.1.2	Usage	857
24.1.3	File Format and Examples	857
24.1.3.1	AKD PDMM	857
24.1.3.2	PCMM	857
24.1.4	Model Code	857
24.2	PCMM2G - File Naming Conventions	858

24.2.1 PCMM2G Firmware Files	858
24.2.2 PCMM2G Operating Source (OS) and License Files	858
24.2.3 Operating System (OS) Build Sources - File Naming Convention	858
24.2.3.1 File Contents	858
24.2.3.2 Usage	858
24.2.3.3 File Format and Example	858
24.2.4 Operating System (OS) License Sources - File Naming Convention	859
24.2.4.1 File Contents	859
24.2.4.2 Usage	859
24.2.4.3 File Format and Example	859
24.2.5 Operating System (OS) + KAS Runtime (RT) - File Naming Convention	859
24.2.5.1 File Contents	859
24.2.5.2 Usage	859
24.2.5.3 File Format and Example	859
24.2.5.4 Model Code	860
24.2.6 Recovery Operating System (OS) + KAS Runtime (RT) - File Naming Convention	860
24.2.6.1 File Contents	860
24.2.6.2 Usage	860
24.2.6.2.1 Reset Changes	860
24.2.6.3 File Format and Example	861
24.2.6.4 Model Code	861
24.2.7 Boot Loader - File Naming Convention	861
24.2.7.1 File Contents	861
24.2.7.2 Usage	861
24.2.7.3 File Format and Example	862
24.2.7.4 Model Code	862
24.2.8 KAS Runtime (RT) Only - File Naming Convention	862
24.2.8.1 File Contents	862
24.2.8.2 Usage	862
24.2.8.3 File Format and Example	862
24.2.8.4 Model Code	862
25 List of Documentation	864
25.1 AKD, AKD2G, S300, and S700 Documentation	864
25.2 AKD PDMM and PCMM Documentation	864
25.3 HMI Documentation	865
25.4 IO Documentation	865
25.4.1 AKT (K-Bus) Terminals	865
25.4.2 AKT2G-IO (EtherCAT) Terminals	867
25.5 KAS Documentation	868
25.6 KVB Documentation	869
26 List of How-Tos	870
26.1 Advanced Motion How-Tos	870
26.2 EtherCAT Fieldbus How-Tos	870
26.3 Hardware How-Tos	870
26.4 PLC Code How-Tos	870
26.5 Run the Application How-Tos	870
27 Licenses	871
27.1 AjaxFileUpload — MPL License	871

27.2	Apache log4net — Apache License	871
27.3	bsdtar and libarchive 2 — BSD License	875
27.4	bzip2.dll — BSD License	875
27.5	DockPanel Suite — MIT License	876
27.6	FileHelpers	876
27.7	jQuery Cookies	878
27.8	jQuery File Tree — MIT License	878
27.9	JavaScript Graphics Library — GNU Lesser General Public License	879
27.10	Mongoose — MIT License	892
27.11	MVVM Light Toolkit — MIT License	892
27.12	pugixml — MIT License	893
27.13	Qt — LGPL3 License	893
27.14	Qwt — GNU Lesser General Public License	896
27.15	ZedGraph — LGPL License	910
27.16	Zlib1.dll — BSD License	920
	Support and Services	921

Document History

Edition	Software Version	Date	Description
Y	4.02	June 2024	Release of PCMM2G.
W	4.01	December 2023	Updated documentation to support PCMM2G.
V	4.00	December 2022	Add compatibility for PCMM2G; Remove obsolete File Management functions.
U	3.07	December 2021	Modular EtherCAT topology, AKT2G-IO-BRC-000 Brake Chopper, saving previous versions of KAS files, link to templates on KDN.
T	3.06	June 2021	Integration of stepper I/O slices and support for stepper motors. Added ECATDevReadParam, MCFB_DriveFault, MLFB_DriveFault, MCFB_ECATRstart, and MLFB_ECATRstart. Access to Bits of an Integer increased to 64-bits.
R	3.05	December 2020	Integration of BBH SCU-1-EC with KAS-IDE and BBH SafePLC2 software; Integration of E-bus AKT2G-IO I/O devices; WorkBench connection improvements; MLAxisReadVel.
P	3.04	June 2020	TCP/IP functions, eitadapter, file management functions, SafePLC support, WorkBench improvements, support AKT2G-IO slices, DriveParamStrRead, multi-select PDO objects for mapping.
N	3.03	December 2019	FSoE; T-Bot / H-Bot / Gantry robotics: Axes Groups, MC_KIN_REF structure, MC_SetKinTra; AKD2G Backup and Restore, MDP support.
M	3.02	June 2019	Map a digitizing axis, AKD2G, multiple instances of KAS-IDE, ElasticSearch, reorder programs.
L	3.01	December 2018	Multiple installed versions, updated UDFBs, Backup Import/Export on webserver, UI improvements, Softscope enhancements, security enhancements.
K	3.0	January 2018	AKD 1.17, AKD2G integration, MC_CreatePLCAxis, MLPNAxisCreate.
J	2.12	June 2017	AKD2G support, AKD 1.16, KVB 2.20, AKIX2 panels, EtherCAT Diagnostics (webserver diagnostics tab, A31, ECATWCStatus, ECATMasterStatus, ECATDeviceStatus, ECATCommErrors), MC_MoveContVel, FFLD Editor Comments, PN Editor Improvements, SSH Security.
H	2.11	September 2016	Parabolic cam profile support, send data to/from a controller via UDP, access KDN from the menu, improved EtherCAT diagnostics, Find All command, find variable instances, access shared directories from the webserver, configurable Modbus slave data exchange rate, double-click editing of FBD and FFLD, F_Seek function, configurable circle center point tolerance.
G	2.10	January 2016	PCMM support, Code generation types: Normal and Optimized, MC_TouchProbe: Time or Position-based capture, MCFB_StepLimitSwitchFastInput, HTML5 help.

Edition	Software Version	Date	Description
F	2.9	May 2015	AKD-C/N support, flexible PDOs, multiple E/IP assembly files, export-compliant firmware, new functions and function blocks, GUI improvements including easier EtherCAT device setup, improved IO and variable mapping, improved IO viewing.
E	2.8	May 2014	Coordinated Motion (3D linear w/ blending and transition; nD w/o blending and amp transition), HTTP variable interface, UDP socket interface, EtherCAT MDP management.
D	2.7	October 2013	Coordinated Motion; EtherCAT device configuration; KVB 2, Softscope; generic Modbus configuration; Dictionary improvements; Control panel changes.
C	2.7	June 2013	Initial doc.
B	2.6	December 2012	EtherCAT devices backup and restore; PLCopen Registration; Superimposed Axes; Cam on the fly; EtherNet/IP; PROFINET; Reset to factory settings; Save project on controller; Password protection.
A	2.5	May 2012	Initial release of KAS-IDE and AKD PDMM.
0.2		September 2010	First release for KAS R1.

1 Preface

Welcome to the Kollmorgen Automation Suite help and documentation!

This document covers the use and programming of the KAS-IDE, the AKD PDMM, PCMM, and PCMM2G information about KAS components, and much more.

This section explains how to use the online help provided with Kollmorgen Automation Suite™.

1.1 System Requirements

KAS-IDE and KAS Simulator are compatible with any PC having this minimum hardware:

These are the minimum system requirements for the KAS-IDE.

Element	Description
Connectivity	<ul style="list-style-type: none"> 1 Ethernet port, at either 100MB or 1GB. See Note #2.
Display	<ul style="list-style-type: none"> WXGA+ (1440 x 900) or higher-resolution monitor with 24-bit, 16.7M colors. See Note #1.
Memory	1GB RAM (for 32-bit) or 2GB RAM (for 64-bit) or greater (recommended for complex applications).
.NET Framework	4.8.1
Processor Type	Intel® Pentium® M or equivalent processor at 1.5GHz or greater.
Storage	16GB (for 32-bit) or 20GB (for 64-bit) of free space on hard disk.
Supported Operating Systems	<ul style="list-style-type: none"> Microsoft® Windows® 10 (32-bit or 64-bit). Microsoft® Windows® 11 (64-bit). For optimal performance, verify the operating system is fully updated with the latest patches.
Web Browser	<ul style="list-style-type: none"> A modern web browser is required to access the web server and online help. We recommend Microsoft Edge.

NOTE

- Better results are achieved with OpenGL and 3D cards.
- A 100MB network is required to allow the KAS-IDE to Runtime communication to work in all conditions. The AKD WorkBench AutoTuner and Scope both require 100MB of bandwidth to function properly.

TIP

See [Connect Remotely](#) about the ports used by the KAS-IDE.

The ports may need to be opened to support connecting from an external network.

2 Introducing Kollmorgen Automation Suite

This section introduces Kollmorgen Automation Suite (KAS) with a product overview that lists the features, components, and different implementations.

KAS is intended for engineers to design and build high-performance motion control and automation systems. KAS is designed to quickly and easily compose a motion application. It can be achieved with all of the re-use and flexibility of the KAS libraries in conjunction with the IEC 61131-3 programming languages.

As can be seen, KAS can cover a wide variety of applications:

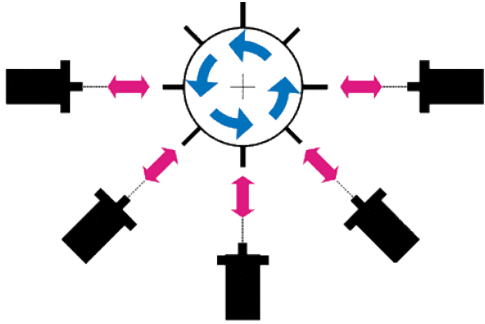

Figure 2-1: Synchronized Feeder

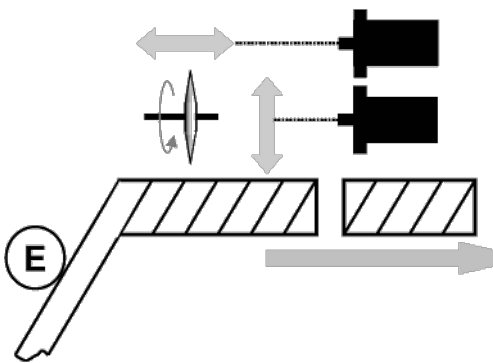

Figure 2-2: Spring Winding

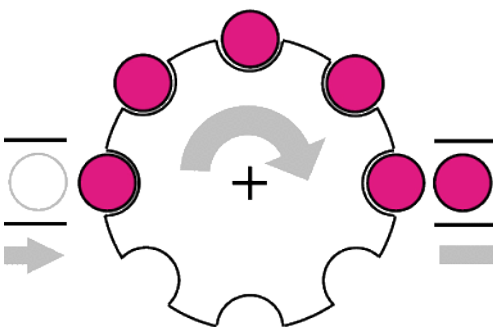

Figure 2-3: Synchronizer

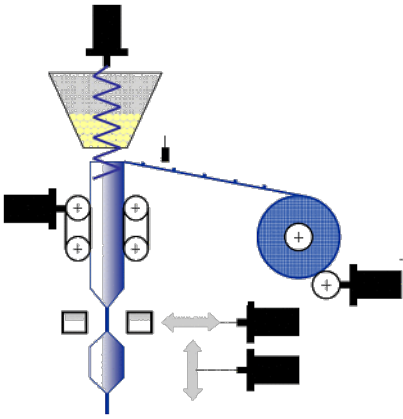

Figure 2-4: Form Fill Seal

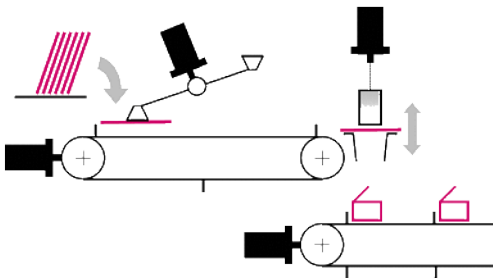

Figure 2-5: Carton Erector

2.1 Learning Kollmorgen Automation Suite

To learn Kollmorgen Automation Suite (KAS), you can:

- Navigate this online help and choose sections depending on your experience.
- Read the KAS Manuals (→ p. 43).

2.1.1 Where to Start

The KAS documentation includes information for readers from a variety of backgrounds.

TIP

To get the most out of the documentation, we recommend you start reading the sections that are most relevant to you. Within each section, read through the topics in sequence.

2.1.1.1 Beginner

- Find basic information about KAS in "Introducing Kollmorgen Automation Suite" (→ p. 41).
- If you are not familiar with the concepts behind KAS, read the "Understanding KAS" (→ p. 702).
- An overview of the KAS-IDE User Interface is in "Describing the KAS Graphical User Interface" (→ p. 70).
- To get information on how to run and debug the project, read "Start the KAS Simulator" (→ p. 226) and "Testing and Debugging the Project" (→ p. 231).

2.1.1.2 Advanced User





- To design and create a project, see "Getting Started" (→ p. 128).
- For explanations about the tools used by the KAS-IDE, see "Tools" (→ p. 444).
- For in-depth information, see "Advanced Topics" (→ p. 514).



2.1.1.3 Online

- KDN: The Kollmorgen Developer Network (KDN) has many articles, resources, and a user community to learn, ask questions, and contribute to our community.
 - See KDN at <https://www.kollmorgen.com/en-us/developer-network/>
- YouTube: Kollmorgen has a channel dedicated to KAS.
 - See the [KAS Online Learning Collection](#).

2.1.2 Read the KAS Manuals

If you prefer to read printed material, these manuals (in PDF format) are available in the C:\Program Files\Kollmorgen\Kollmorgen Automation Suite\Help folder.

Document Title	Description	Download
Release Notes	<p>The KAS Release Notes contain a summary of:</p> <ul style="list-style-type: none"> • New features, fixed and known limitations, workarounds • Information on all hardware and software components that have been updated, changed, or added in the release. 	
Getting Started	<p>Contains these main steps to get the KAS system up and running.</p> <ul style="list-style-type: none"> • Hardware (HW) Installation (Connection and Wiring): Wiring and hardware details, connectors, system diagrams. • HW Configuration: Basic configuration and settings needed to start the HW components (e.g., HMI, Industrial PC, Fieldbus, I/O). • Software (SW) Installation: KAS software setup. 	
30 Minutes to Motion	<p>Contains the main topics to get started quickly with KAS-IDE. The objective is to familiarize you with the basic principles and the way the program works by creating a simple motion application project. This document contains information about:</p> <ul style="list-style-type: none"> • Key Features <ul style="list-style-type: none"> • See the Key Features in KAS. • Explore the Workspace <ul style="list-style-type: none"> • See "Describing the KAS Graphical User Interface" (→ p. 70). • Build a Motion Project <ul style="list-style-type: none"> • Almost every task performed in KAS falls under one of these basic steps (which may not always be completed in this order): <ul style="list-style-type: none"> • Start Projects - Create a project from scratch or modify an existing project. See Create a Project. • Add Components - Add necessary elements to build the project and control the motion part of the system. This includes: "Create Variables" (→ p. 303), "Adding Motion" (→ p. 158), and "Programs: Structure and Syntax" (→ p. 269). • Build Output - Select a device and generate the application to deliver to users. See "Run the Project" (→ p. 222). • Run Output - Make the output accessible to end-users. 	
KAS-IDE User Manual	<p>Contains content to help with KAS-IDE except the topics included in the Reference Manuals.</p>	

Document Title	Description	Download
Reference Manual - PLC Library	Contains Technical References on PLC Programming Languages and Library.	
Reference Manual - Motion Library	Contains Technical References on Motion Library for Pipe Network and PLCopen.	

TIP

The KAS-IDE allows "References" (→ p. 81) to external files (e.g., the PDF files).
See (→ # 246, Use the Reference Folder).

2.2 Key Features

The purpose of KAS is to include, in a single software package, all the tools you need (i.e., a soft PLC, configuration tools, and a motion controller) to create an automation system.

An overview of an investment in Kollmorgen for Motion Control and Automation Systems solution is shown in Figure 2-6:

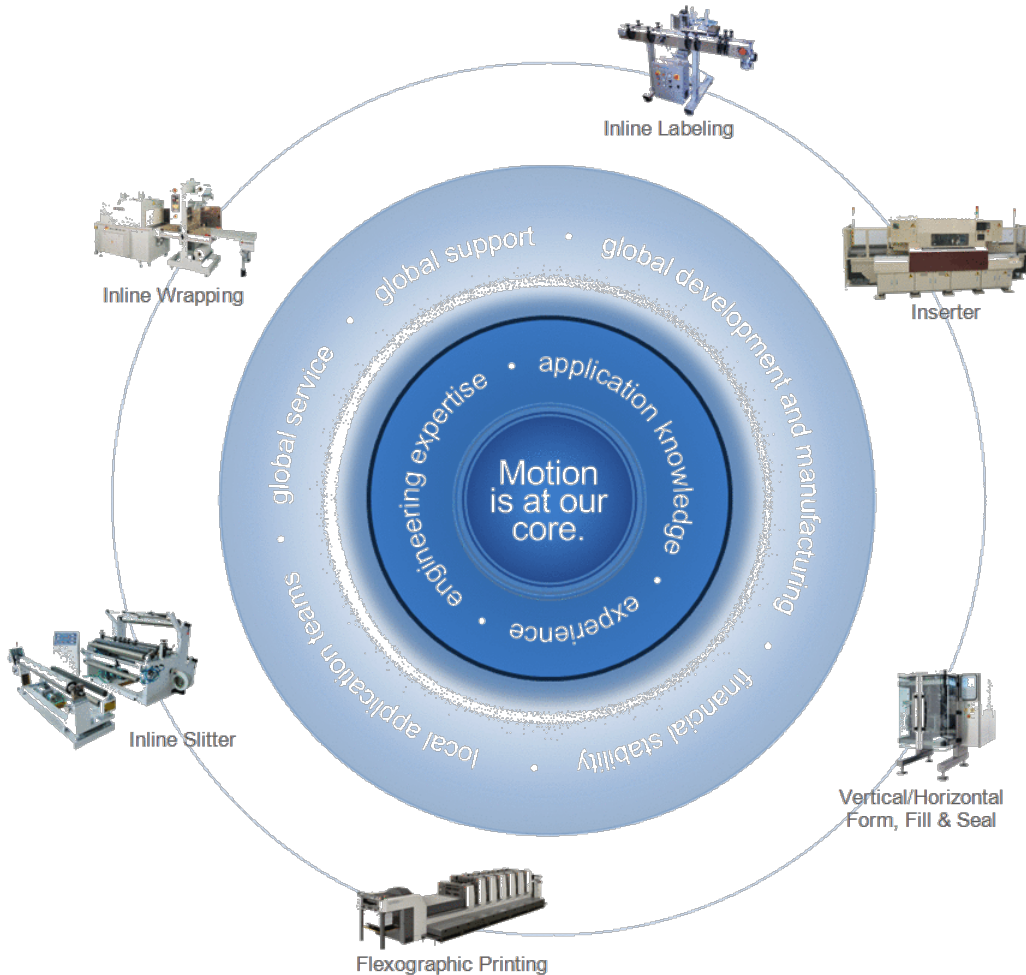

Figure 2-6: Motion at our Core

- KAS is Kollmorgen's all-in-one solution for designing, developing and maintaining automation systems.
 - As a solution offering, it brings many years of Motion Control experience to the market and this is coupled with technical expertise and experience, global delivery capability, and strong financial performance.
- KAS is a set of software packages designed to run and take advantage of Kollmorgen's extended set of these integrated hardware products:
 - Programmable Automation Controllers
 - Programmable Drives
 - AKD drive family
 - AKM motor family, gear boxes, I/O terminals and Human Machine Interaction terminals (or Operator Interfaces.)
- KAS provides machine builders with a high-performance, cost-effective, and easy to use solution for building machines.
- KAS achieves this by integrating in a coherent, intuitive, and flexible way these main functionalities of a machine:

- Precise control of all moving parts (Motion control)
- Interface with machine operators (HMI)
- PLC programming of the machine (IEC 61131-3 Soft PLC)

KAS is made of these software components:

- KAS-IDE - the Integrated Development Environment allowing development and monitoring of complex machine automation systems.
- KAS Runtime - the Runtime engine offers the functionality of both a **High-Performance Motion and a PLC Engine**.

2.2.1 Kollmorgen Automation Suite-Integrated Development Environment (KAS-IDE)

KAS comes with a powerful Integrated Development Environment.

- The KAS-IDE provides machine builders with all the necessary tools for designing, programming, configuring, debugging, and maintaining machine applications.
- KAS uses the same interface, tools, and libraries to create applications for various types of KAS controllers (AKD PDMM, PCMM, and PCMM2G).

With the KAS-IDE, system engineers can:

- Create new application projects using predefined or custom application templates.
- Define the machine hardware architecture ("Fieldbus" (→ p. 66), "Motion Bus" (→ p. 66), "Controllers" (→ p. 58), "Drives" (→ p. 692), and motors) and the machine program (HMI panels, IEC 61131-3 [programs and function blocks](#), motion block, [profiles](#) and axes) from a centralized [Project Explorer](#) which is based on a tree-structure.
- Develop [PLC programs, functions and function blocks](#) using the:
 - IEC 61131-3 programming languages (FBD, FFLD, IL, SFC, and ST).
 - IEC 61131-3 standard library.
 - KASFunction Block libraries dedicated to motion, communication and monitoring.
- Centrally manage all IEC 61131-3 variables with KAS variable dictionary on the "Variables tab" (→ p. 86).
- Create and organize libraries of functions and function blocks.
- Easily set up **HMI panels** using the "Human-Machine Interface Editor" (→ p. 458) that is part of the HMI control library and map graphical objects to IEC 61131-3 variables.
- Graphically design advanced multi-axis relations using **Kollmorgen's graphical motion programming** environment, the Pipe Network, with its [tool](#) generating code automatically.
- Use ultra-fast IEC 61131-3 compiler to validate the syntactical correctness application code.
- Configure hardware devices via an integrated set of configuration tools (e.g., [AKD drives](#), [EtherCAT I/O terminals](#), etc.)
- Access controller devices to [download, start and stop the application, watch log messages and send shell commands](#) to the target device.
- Debug the application by inserting [break points](#) and [stepping](#) into the code or by monitoring internal values (IEC 61131-3 variables, motion positions, drive's internal values) directly in the editors or with KAS advanced [Softscope](#) tool.
- Access the full online documentation.

See Also

Motor Reference Material

2.2.2 KAS Runtime

Kollmorgen Automation Suite Runtime (commonly named **KAS Runtime**) offers, in a single software package, the functionality of both a soft PLC and a motion controller.

KAS Runtime (virtual machine) is a high-performance deterministic environment designed to run on different hardware platforms ranging from low-cost **programmable drives** to **high-end Programmable Automation Controllers**. This gives machine builders all the flexibility when designing their machines.

KAS supports many configurations when integrating machines:

- Ranges from **single-axis** to more than **200 tightly coordinated axes**.
- With a **centralized** (Programmable Automation Controllers), **distributed** (Programmable Drives) or **mixed** (Programmable Automation Controllers + programmable drives) control architecture.
- Runs on a **single or multiple controllers**.
- Communicates via Ethernet, EtherCAT, PROFINET, EtherNet/IP, or Modbus.
- Uses the high-performance Pipe Network or the standard PLCopen function blocks.
- Controls Kollmorgen's drives (AKD, some of the Servostar Sxxx drive family), AKM motors, and AKT terminals for I/Os products).

The KAS Runtime can be used in these contexts:

- Controller implementation (PCMM or PCMM2G)
- A master drive implementation (AKD PDMM)

See (→ # 68, Different Implementations).

2.2.3 KAS Simulator

Thanks to the **KAS Simulator** tool, development of the machine software can start before (or parallel with) bringing in production. Thus developers can already begin to develop and test their application without any hardware available. Once ready, the application can be deployed on the targeted controller.

By allowing developers to run the full application (HMI, soft PLC, motion and I/Os) totally independently from the final targeted machine, KAS helps reducing:

- **Development time**, by limiting down time waiting for other engineers (mechanical, electrical...) to test, fix and tune the real machine
- **Cost**, by limiting broken hardware due to software bugs.

See "Using the KAS Simulator" (→ p. 361) for more information.

2.3 Looking at Kollmorgen Automation Suite

2.3.1 Architectural View

This diagram shows an architectural view of what KAS is from a hardware and software perspective, or Real-time and not Real-time components.

- Hardware is shown in blue shaded boxes and, minimally consists of a computer, a controller, one or more drives, I/O, and optionally an HMI device.
 - Each of these components has a software aspect, many of which communicate with other components.
- Communication may be done over:
 - Ethernet or HTTP (in blue)
 - EtherCAT (in green)
 - Modbus (in red)
 - Several other protocols

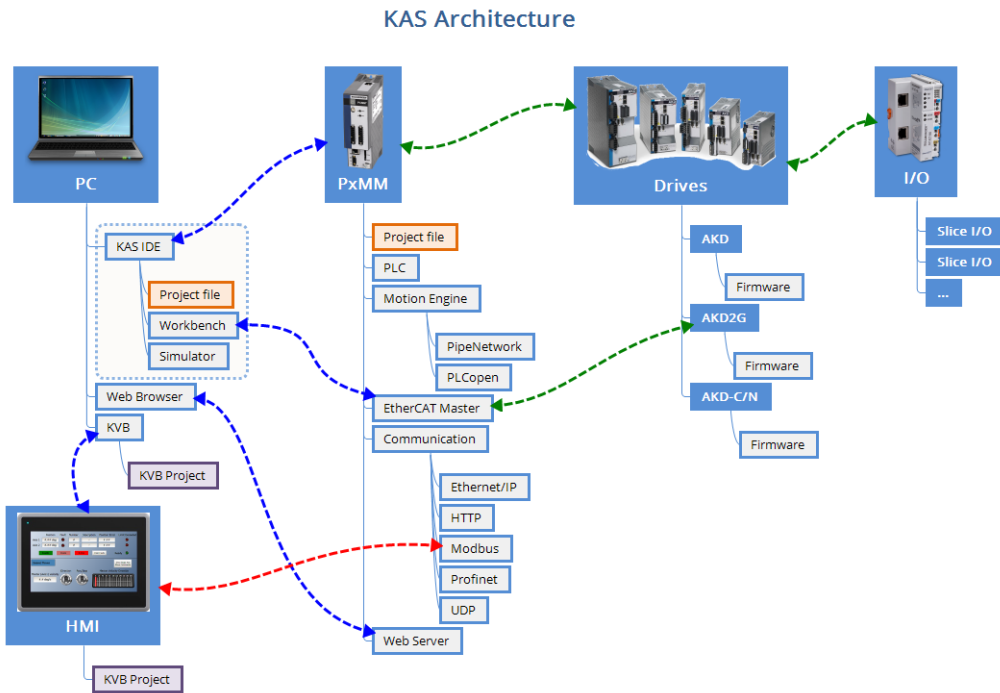

Figure 2-7: Architectural view of KAS components

2.3.1.1 Real-Time

The real-time components, including those running the KAS Runtime engine, consists of:

Item	Description
IEC 61131-3 virtual machine	Responsible for managing an IEC 61131-3 application with its programs and variables.
Motion manager	<p>Manages motion engines, axis objects and motion bus drivers. The KAS Runtime comes with these motion engines: "Pipe Network Concept" (→ p. 727) and "PLCopen®" (→ p. 743).</p> <ul style="list-style-type: none"> The motion engine implements different motion algorithms and functions to create, access, and delete pipes, pipe blocks, and axes (e.g., MLPNAxisCreate, MLGearInit, MLPipeAct). It provides a set of Functions and Function Blocks that IEC 61131-3 applications can use to control the behavior of these algorithms
I/O manager	Manages I/Os and I/O drivers. It works closely with the VM Manager instances to map transparently all IEC 61131-3 variables declared as input or output.
Motion Bus	A plug-in giving access to the EtherCAT network.
custom function blocks	A plug-in implementing to "Create and Use Custom Libraries" (→ p. 209) with function blocks.

2.3.1.2 Non-Real-Time

The non-real-time part is composed of:

Item	Description
KAS-IDE	The development tool used to create the project (i.e., design, create and run virtually).
KAS Runtime	...
KVB	The development tool used to create an HMI interface.
HMI	Available when integrated on a Programmable Automation Controller platform (not present when integrated a programmable drive).

Interface between the real-time and non-real-time systems is done via shared memory buffers.

The Runtime communicates with the KAS-IDE during operation to:

- Receive further instructions from the KAS-IDE such as a direct motion command.
- Provide status information to the KAS-IDE for motion and operation of the application program.
- Provide information displayed on the KAS-IDE scope.
- Provide Log information to the KAS-IDE.

NOTE



When the KAS Runtime is implemented with a programmable drive, the interface between the real-time and non-real-time parts is done via Ethernet based on TCP/IP protocol.

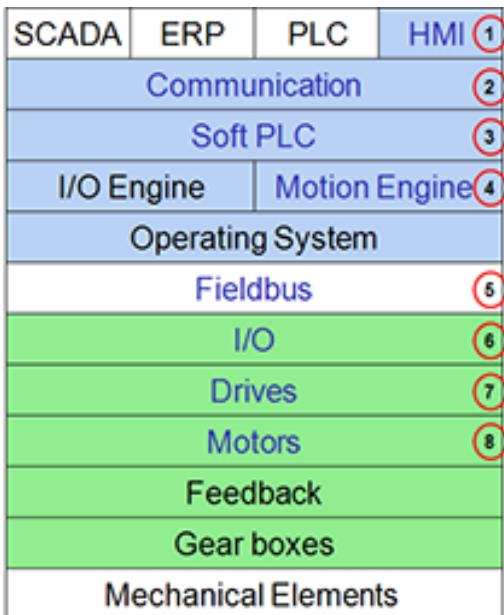

2.3.2 Logical View

An automation system usually needs an organized hierarchy of controller systems to function.

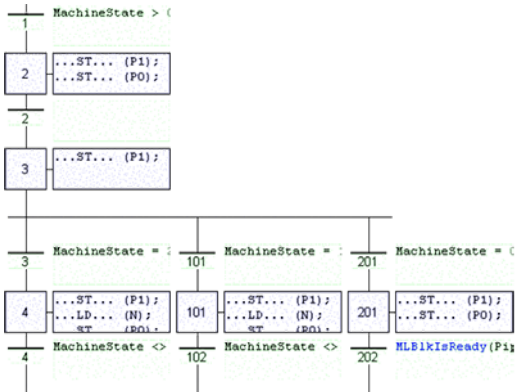
This system usually includes these items:

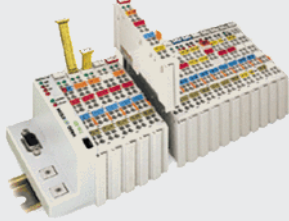

Call out#	Item	Description
1	HMI	<p>At the end-user top level, the Human Machine Interface is where the operator can monitor or operate the system.</p> <ul style="list-style-type: none"> It is usually composed of an AKI panel. An HMI is usually employed to communicate with PLCs for further automated control or emergency response. PLCs usually have built-in communications ports. 
2	Communication	<p>HMI is linked to the middle layer via a non time critical communication system (e.g., Modbus TCP protocol on Ethernet).</p>
3	PLC	<p>A Programmable Logic Controller is a digital computer used for automation of industrial processes (e.g., control of machinery on factory assembly lines). It is used to synchronize the flow of inputs from (physical) sensors and events with the flow of outputs to actuators and events.</p> 
4	Motion Engine	<p>There are two Motion Engines available:</p> <ul style="list-style-type: none"> "Pipe Network Concept" (→ p. 727) "PLCopen®" (→ p. 743) <p>The Motion Engine implements different motion algorithms and functions to create, access and delete pipes, pipe blocks and axes. It provides a set of Functions and Function Blocks that IEC 61131-3 applications can use to control the behavior of these algorithms.</p>
5	Fieldbus	<p>A fieldbus is an industrial network system for real-time distributed control (e.g., CAN).</p> <ul style="list-style-type: none"> It is a way of connecting instruments in a plant design is the industrial network system that controls the motion. Communicating frames requires high performance and reliability to ensure real-time distribution. The fieldbus is the way to connect instruments in a plant design by linking the PLC to the external systems. 

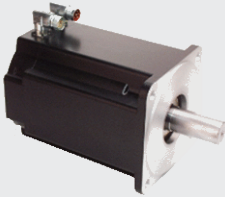
Call out#	Item	Description
6	I/O	<p>Input/Output refers to the communication between an automation system and the outside world.</p> <ul style="list-style-type: none">• Inputs are the signals or data received by the automation system.• Outputs are the signals or data sent from it. 
7	Drive	<p>A Drive is an electronic device that provides power to a motor or servo.</p> 
8	Motor	<p>At the bottom of the control chain is the motor which actually does the work.</p> <ul style="list-style-type: none">• Motors are mostly used when circular motion is needed.• They can also be used for linear applications by transforming circular to linear motion with a bolt and screw transducer.<ul style="list-style-type: none">• Some actuators, however, are intrinsically linear. 

2.3.3 Physical View

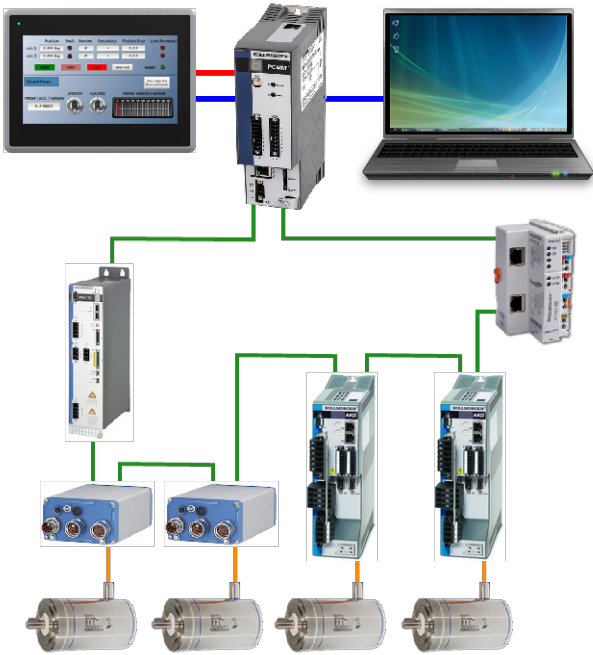



Figure 2-8: Example of Automation System



Color	Method of communication
Blue	Ethernet
Green	EtherCAT
Red	Modbus
Orange	Motor cable

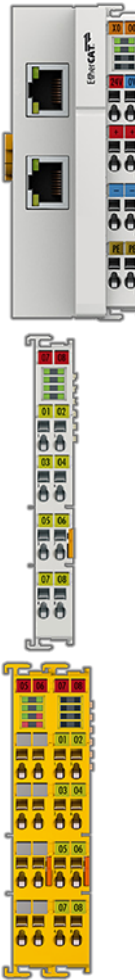

2.4 Kollmorgen Automation Suite (KAS) Breakdown

Domain	Product	Product Example Image	Concept (Technology)	Installation	Tasks (Tools)	Reference
Controller	AKD PDMM PCMM PCMM2G		Programmable Drive Multi-axis Master: "Controllers" (→ p. 58)	<ul style="list-style-type: none"> Install the AKD PDMM, PCMM, or PCMM2G controller. See Install Controllers. 	<ul style="list-style-type: none"> "Add the Controller" (→ p. 133) "Configure the Controller" (→ p. 135) 	"Controllers" (→ p. 685)

Domain	Product	Product Example Image	Concept (Technology)	Installation	Tasks (Tools)	Reference
Drives	AKD AKD-C AKD-N AKD2G S300 S700		<ul style="list-style-type: none"> • AKD • AKD-C • AKD-N • AKD2G • S300 • S700 	<ul style="list-style-type: none"> • Install a AKD or AKD2G Drive. • See either the: <ul style="list-style-type: none"> • AKD Installation Manual • AKD Quick Start • Available from: AKD Downloads. 	<ul style="list-style-type: none"> • "Add and Configure a Servo Drive" (→ p. 190) • "AKD Drive Configuration" (→ p. 817) • Download AKD PDMM Drive Firmware • AKD/AKD2G Firmware Update 	"Drives" (→ p. 692)
Fieldbus	EtherCAT		EtherCAT	<ul style="list-style-type: none"> • Set up EtherCAT Motion Bus Communication. • See AKD@EtherCAT Communication. 	"Configure EtherCAT Motion Bus" (→ p. 138)	"Motion Bus and Fieldbuses" (→ p. 579) Cables
HMI	Human-Machine Interface			<ul style="list-style-type: none"> • Install the graphic operator interface. • See HMI - Graphic Operator Interface. 	<ul style="list-style-type: none"> • "Using Kollmorgen Visualization Builder" (→ p. 458) • "Add an HMI Device" (→ p. 185) 	"HMI" (→ p. 696)

Domain	Product	Product Example Image	Concept (Technology)	Installation	Tasks (Tools)	Reference
I/O Terminal			EtherCAT	<ul style="list-style-type: none"> • Install the remote Input/Output Terminal. • See Remote Input/Output - I/O Terminal. 	<ul style="list-style-type: none"> • "Add and Configure I/O Slices" (→ p. 201) • "Map Input and Output to Variables" (→ p. 314) 	"Remote Input/Output Terminals" (→ p. 697)

Domain	Product	Product Example Image	Concept (Technology)	Installation	Tasks (Tools)	Reference
Mechanical						Linear Actuators Gearheads
Motion Engines			<p>Motion Concept:</p> <ul style="list-style-type: none"> "Pipe Network Concept" (→ p. 727) "PLCopen®" (→ p. 743) 		<ul style="list-style-type: none"> Design Pipe Network Pipe Network Editor Create Cam Profile Cam Profile Editor Softscope 	
Motors	AKM AKM2G		Kollmorgen Servomotor	<ul style="list-style-type: none"> Install the AKM or AKM2G Motor. Mechanical and Electrical installation. Available from: <ul style="list-style-type: none"> AKM Downloads AKM2G Downloads 		<ul style="list-style-type: none"> AKM AKM2G Cartridge DDR Direct Drive Linear Housed DDR KBM TBM

Domain	Product	Product Example Image	Concept (Technology)	Installation	Tasks (Tools)	Reference
PLC			"IEC 61131-3" (→ p. 702)		<ul style="list-style-type: none"> "Free Form Ladder Diagram (FFLD) Editor" (→ p. 284) "Function Block Diagram (FBD) Editor" (→ p. 274) "Sequential Function Chart (SFC) Editor" (→ p. 293) "Soft Oscilloscope" (→ p. 484) (Softscope) "Structured Text (ST) / Instruction List (IL) Editor" (→ p. 299) "Variables tab" (→ p. 86) for Dictionary 	<ul style="list-style-type: none"> FBD Language FFLD Language IL Language SFC Language ST Language
Safety			"Safety over EtherCAT" (→ p. 792)	"SafePLC2 Projects" (→ p. 189)	<ol style="list-style-type: none"> "SafePLC2 Projects" (→ p. 189) "Set Up a Variable to Monitor Safety Data" (→ p. 344) "AKD2G Safety Parametrization Using FSoE with SCU-1-EC and PxMM / PCMM2G" (→ p. 584) "Set Up FSoE Master and an AKD2G with SafeMotion Monitor" (→ p. 582) 	<ul style="list-style-type: none"> "BBH FSoE Master" (→ p. 685) "Related Documents" (→ p. 692) AKT2G-SDI-004-000 AKT2G-SDO-004-000

2.4.1 Human-Machine Interface



Figure 2-9: Hardware to Display the Human-Machine Interface

A Programmable Logic Controllers (PLC) interacts with people for the purpose of configuration, alarm reporting or everyday control. A Human-Machine Interface (HMI) is employed for this purpose.

- A simple system uses buttons and lights to interact with the end-user.
- Text and graphic displays are available on the touch panels.

Most modern PLCs can communicate over a network to some other systems, such as a computer running a SCADA system.

The communication between the HMI and the PLC is based on Modbus over TCP/IP (Modbus TCP is the Ethernet version of Modbus) by means of a standard Ethernet cable that connects the two devices.

This communication is done in the background, asynchronously, at the cycle time (20-1000 milliseconds) specified in the Controller Properties. See "Configure the Controller" (→ p. 135) for more information.

- Variables defined in the HMI to describe the interface are passed to the controller this way.
 - See "Map Variables to HMI" (→ p. 186) for more information.
- This means there is no data coherency in the data exchange because the variables read by the Modbus do not come from the same PLC cycle.
- This data has a rather low priority.
 - It is interpreted by human feedback and should never be noticed by the user.

NOTE

Kollmorgen HMIs are limited to communicating no more frequently than every 100 milliseconds.

2.4.2 Controllers



Figure 2-10: Kollmorgen Controllers

These are the Kollmorgen Automation Suite controllers:

- PCMM2G - Programmable Controller Multi-Axis Master 2nd Generation.
- PCMM - Programmable Controller Multi-Axis Master.
- AKD PDMM - Programmable Drive Multi-Axis Master)

2.4.2.1 AKD PDMM and PCMM Hardware

The AKD PDMM has three printed circuit boards (PCB).

The PCMM has one PCB.

- Power board (AKD PDMM only)
- AKD control card (AKD PDMM only)

AKD PDMM and PCMM option card, available in these variants:

AKD PDMM

- NXP/Freescale QorIQ P1011 processor (800MHz).
- NXP/Freescale QorIQ P2010 processor (1.2GHz).

PCMM

- NXP/Freescale QorIQ P2010 processor (1.2GHz).
- NXP/Freescale QorIQ P2020 processor (Dual Core 1.2GHz).

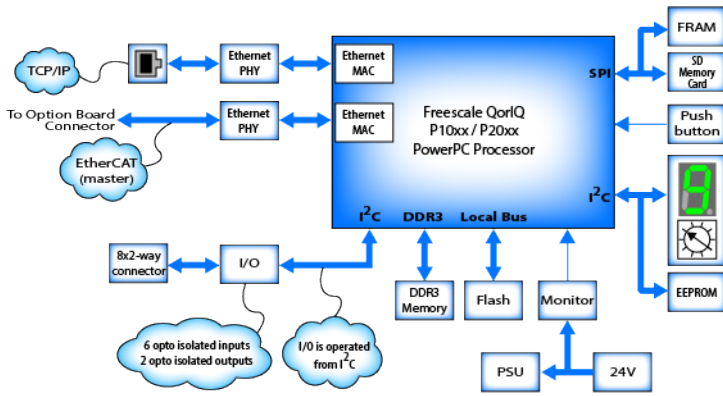

Figure 2-11: AKD PDMM and PCMM card

NOTE

Unless otherwise noted, any reference to AKD PDMM or PCMM refers to both the 800MHz and the single- and dual-core 1.2GHz variants.

2.4.2.2 Controller Rotary Switch



The rotary switch on a Kollmorgen controller is set from a 0 to 9 position.

Switch Position	Description
Position 0	<ul style="list-style-type: none"> The controller tries to get an IP address from a DHCP server. If the DHCP fails, the controller uses AutoIP to get a usable IP address.
Position 1	Either: <ul style="list-style-type: none"> The default static IP address of 192.168.0.101. A custom IP address.
Position 2-9	<ul style="list-style-type: none"> The controller is pre-configured with static IP addresses. The IP addresses range is from: <ul style="list-style-type: none"> 192.168.0.102 (Position 2) to 192.168.0.109 (Position 9)

TIP

If a DHCP server is not present, the drive assumes an Automatic Private IP Address of the form 169.254.x.x.

NOTE

The AKD PDMM and PCMM do not set (or show) an IP address without an attached network cable. On the PCMM2G, if a network cable is not attached or no IP address is assigned, the controller shows an IP address of 0.0.0.0.

2.4.2.3 Controller Web Server

The controllers contain a Web server used to perform these operations:

- Read information about the controller (e.g., model type, firmware version, version of the KAS application).
- Diagnose the system (e.g., CPU speed and usage, total and free storage space, list the EtherCAT devices).
- Configure some parameters (e.g., change the IP address, upgrade the firmware).
- Interact with the application (e.g., Start and Stop the KAS application, see the logs).

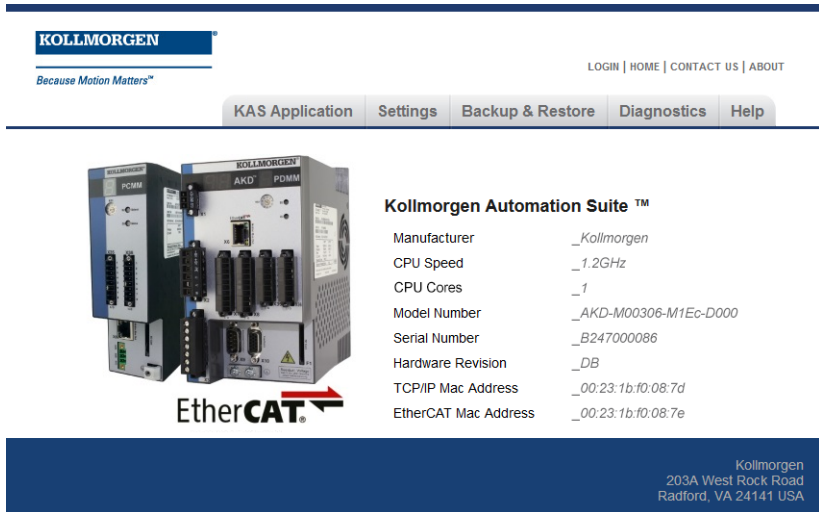

Kollmorgen Automation Suite™

Manufacturer	_Kollmorgen
CPU Speed	_1.2GHz
CPU Cores	_1
Model Number	_AKD-M00306-M1Ec-D000
Serial Number	_B247000086
Hardware Revision	_DB
TCP/IP Mac Address	_00:23:1b:f0:08:7d
EtherCAT Mac Address	_00:23:1b:f0:08:7e

Kollmorgen
203A West Rock Road
Radford, VA 24141 USA

See "Using the KAS Web server" (→ p. 402) for more information.

2.4.2.4 Controller Performance

Kollmorgen offers several controllers with varying performance. This topic compares the relative performance to help you decide what is best for your needs.

This topic has these sections:

- "Examples: Performance Graphs" (→ p. 61)
- "Pipe Network and PLCopen Applications" (→ p. 65)
- "Application Complexities" (→ p. 63)
- "Performance FAQs" (→ p. 65)

2.4.2.4.1 Examples: Performance Graphs

These graphs are for guidance in initial controller selection for development.

- "Single Core" (→ p. 61)
- "Dual Core" (→ p. 62)
- "PCMM2G Controllers" (→ p. 62)

Notes

- During development, the performance of an application should be measured to ensure that the selected controller meets the performance requirements.
- Measurements can be done with either the:
 - KAS's digital oscilloscope using the trace times traces.
 - GetCtrlPerf function block.
 - Observation of the CPU usage on the "Diagnostic tab" (→ p. 440) tab of the KAS controller's web page interface.

2.4.2.4.2.1 Single Core

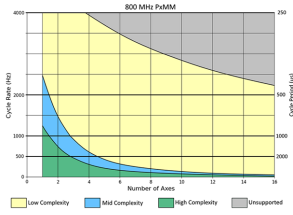

Figure 2-12: 800MHz Single-core

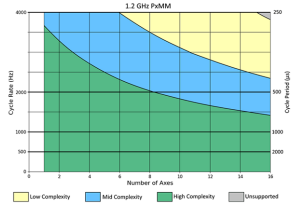

Figure 2-13: 1.2GHz Single-core

2.4.2.4.3.2 Dual Core

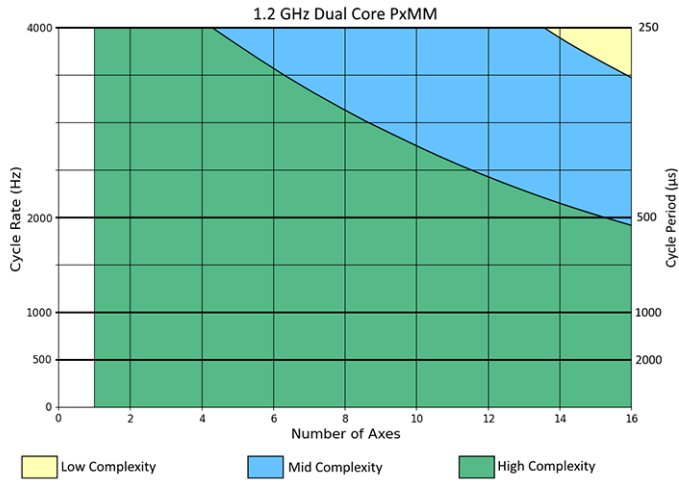

Figure 2-14: 1.2GHz Dual-core

2.4.2.4.4.3 PCMM2G Controllers

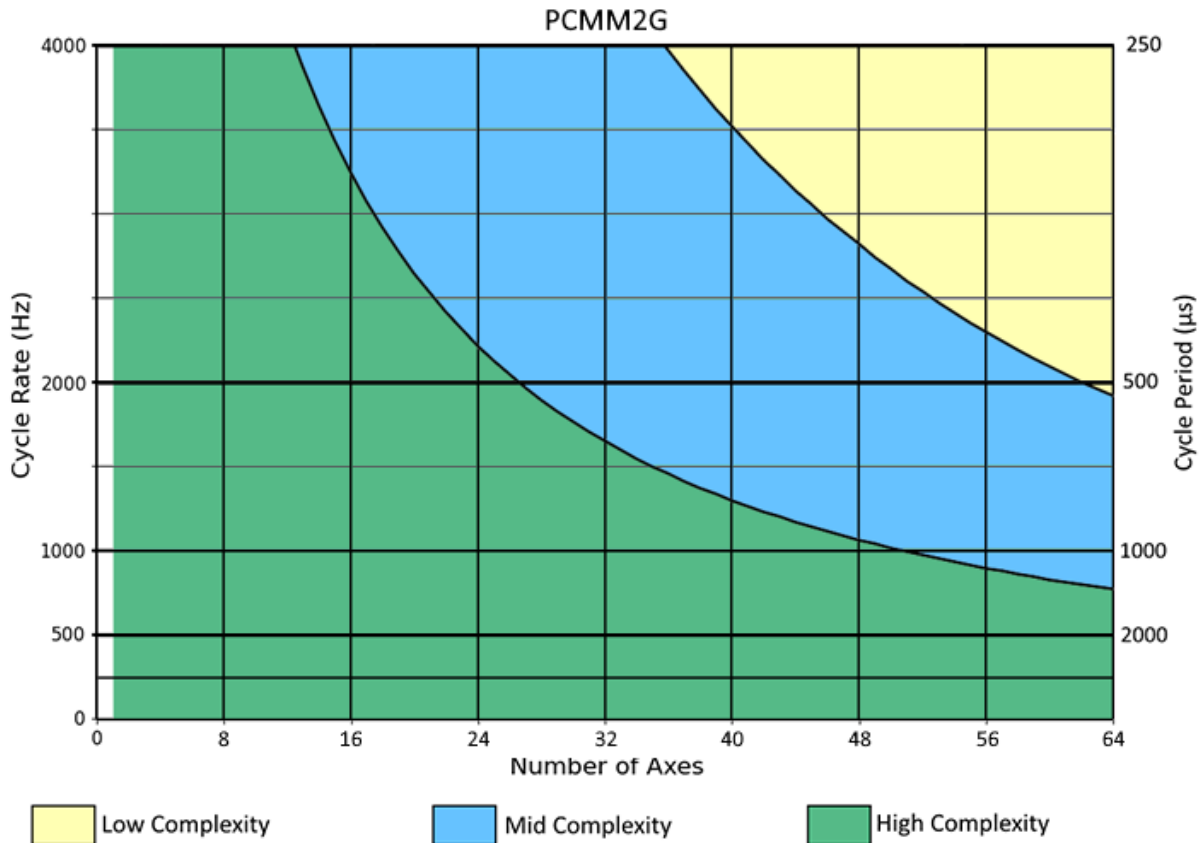

Figure 2-15: PCMM2G Controllers

2.4.2.4.5 Application Complexities

2.4.2.4.6.1 High Complexity

A **high-complexity** application is characterized by:

- Complex setups.
 - Most axes being slave axes.
 - Cammed or geared to a master axis.
- Frequent moves.
- Frequent reading and setting of external I/O points, and complex PLC logic.

[Click for a High Complexity Example](#)

A 4-axis high-complexity application running at 1kHz (1000us) can be handled by a single-core 1.2 GHz PxMM.

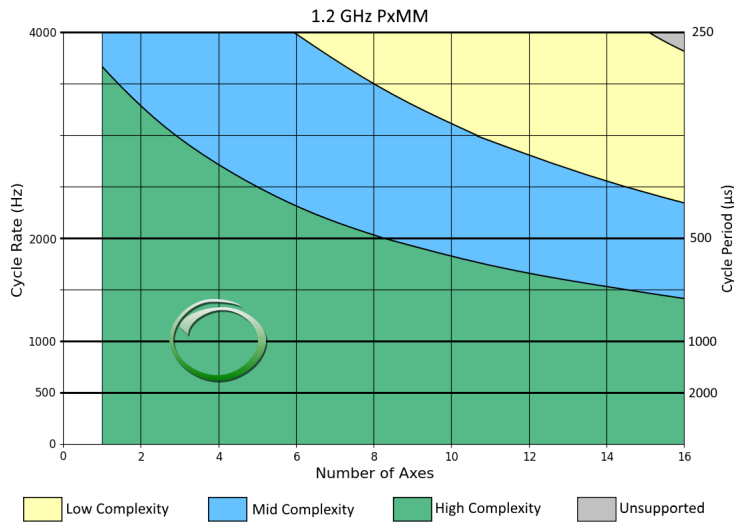

Figure 2-16: Example: High Complexity

2.4.2.4.7.2 Middle Complexity

A **middle-complexity** application is characterized by:

- Being in between High and Low Complexity.
- Most axes are point-to-point or velocity moves.
 - Some axes are cammed or geared to a master.
- PLC logic is split so parts of a complex logic run at given times.

[Click for Middle Complexity Example](#)

A 12-axis middle-complexity application running at 4kHz (250us) requires the dual-core 1.2 GHz PxMM.

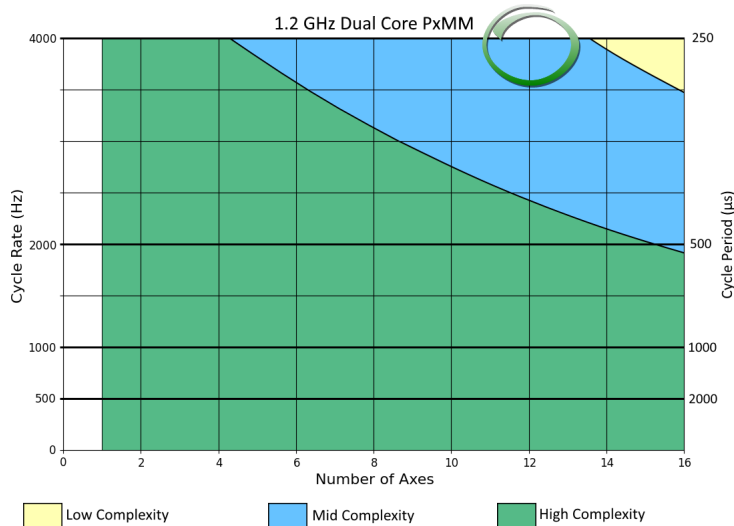

Figure 2-17: Example: Middle Complexity

2.4.2.4.8.3 Low Complexity

A **low-complexity** application is characterized by:

- Point-to-point and velocity moves.
- Occasional reading of external I/O points, and simple PLC logic.

[Click for a Low Complexity Example](#)

A 10-axis low-complexity application running at 2kHz (500us) can be handled by an 800 MHz PxMM.

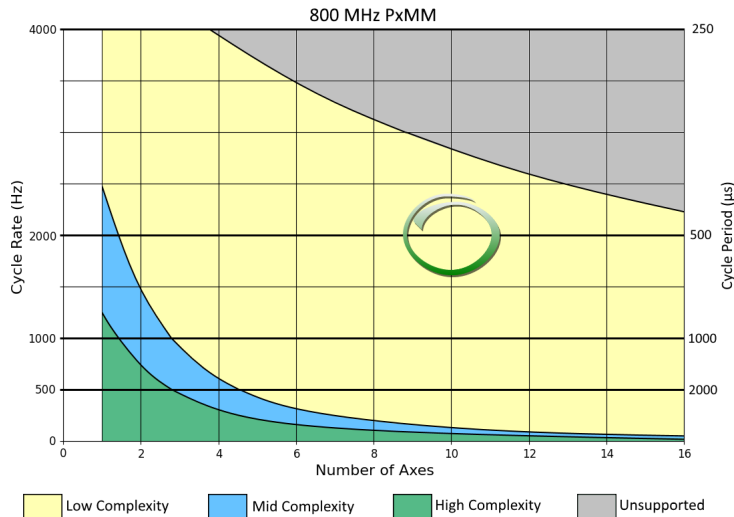

Figure 2-18: Example: Low Complexity

2.4.2.4.9 Pipe Network and PLCopen Applications

Pipe Network applications usually use less of the controller's CPU.

When using the graphs:

- A Pipe Network application acts like a slightly "Low Complexity" (→ p. 64) application.
- A PLCopen application acts like a slightly "High Complexity" (→ p. 63) application.

2.4.2.4.10 Performance FAQs

Should I use a single 800MHz, single-core 1.2GHz, dual-core 1.2GHz, or PCMM2G controller?

To determine which controller model to use for initial development of an application, the axis count and cycle rate of the application can be used to determine what type of application can be run on different controllers.

Example

You are planning a middle-performance application for 6 axes that runs at a 2kHz (500us) cycle rate.

Use these requirements:

- The single-core 1.2GHz PxMM can handle a "High Complexity" (→ p. 63) application.
- The 800MHz PxMM can only handle a "Low Complexity" (→ p. 64) application.
- **Solution:** Since only a "Middle Complexity" (→ p. 64) application is needed, the single-core 1.2GHz PxMM should be sufficient for this application.

TIP

If in doubt, start with a higher-performance controller model and, after optimizing the application code, determine if a lower-performance model will meet the present and future needs for the application.

How much improvement will I get in moving from a single-core 1.2GHz PxMM to a dual-core PxMM?

The dual-core PxMM improves performance by running PLC code and motion code at the same time.

- Typical performance gain varies from 45% to 80%, depending on the type of application being run.
- The greatest performance gain is obtained when PLC code execution time and motion code execution time, measurable using the trace times feature, are roughly the same.
- If one of these two values dominate the execution time, the performance gain is on the smaller side.
- See "Practical Application: Using Trace Time To Measure CPU Load" (→ p. 499).

How much improvement will I get in moving from a single-core 1.2GHz PxMM to a PCMM2G?

The PCMM2G improves performance by running PLC code and motion code at the same time.

- Typical performance gain varies from 130% to 300%, depending on the type of application being run.
 - This is 2.3 to 4 times the performance of the 1.2GHz PxMM.
- The greatest performance gain is obtained when PLC code execution time and motion code execution time, measurable using the trace times feature, are roughly the same.
- If one of these two values dominate the execution time, the performance gain is on the smaller side.
- See "Practical Application: Using Trace Time To Measure CPU Load" (→ p. 499).

Can I downgrade the controller used to run my application?

If using these controllers with the designated peak CPU usage, downgrade to the identified controller.

Active Controller	Peak CPU Usage	Downgrade to this Controller
PCMM2G	Under 35%	Dual-core PxMM
PCMM2G	Under 25%	Single-core 1.2GHz PxMM
Dual-core PxMM	Under 40%	Single-core 1.2GHz PxMM
Dual-core PxMM	Under 25%	800MHz PxMM
Single-core PxMM	Under 50%	800MHz PxMM

See "Diagnostic tab" (→ p. 440) for more information.

[KDN has an article](#) with a tool to help pick a controller which matches your project needs.

2.4.3 Communication and Fieldbus

2.4.3.1 Fieldbus

Fieldbus allows a machine to be connected to other machines in an automation systems network.

Typically, this connection is referred to as a factory automation network connection.

2.4.3.2 Motion Bus

Motion requires the controller to frequently update the drive with new trajectory setpoints.

The bus involved in the motion control requires it to be able to handle rigid jitter and timing demands including high data throughput and low latency.

2.4.3.3 Ethernet

Ethernet is certainly the most popular communications bus today because it is used in most computer networks.

- Motion control devices using Ethernet allow high-speed connections to computers without requiring special hardware.
- This reduces the cost and time required to make high-speed connections.

2.4.3.3.1 EtherCAT

The EtherCAT technology overcomes the system limitations of other Ethernet solutions.

- The Ethernet packet is no longer received, then interpreted and copied as process data at every connection.
 - Instead, the Ethernet frame is processed on the fly.
- Each slave node reads the data addressed to it, while the telegram is forwarded to the next device.
- Similarly, input data is inserted while the telegram passes through.
 - The telegrams are only delayed by a few nanoseconds.

2.4.4 Input/Output Bus

Input/Output refers to the communication and acquisition of data between your automation system and the outside world (possibly a human, or another information processing system).

- Inputs are the signals or data received by the automation system.
- Outputs are the signals or data sent from it.

Automation systems built with KAS are interrupt-driven.

Typical interrupt uses include: system timers, disks I/O, power-off signals, and exceptions handling.



Figure 2-19: I/O Modules

I/O modules provide a convenient modular package which is simple to wire and add or change slice types.

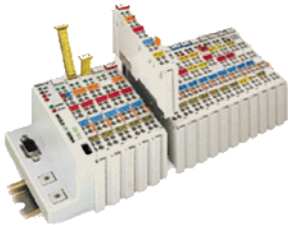

Figure 2-20: Standard I/O Couplers and Slices

2.4.5 Drives



See "Drives" (→ p. 692).

2.4.6 Kollmorgen Motors



Click the product image to open the respective product page on Kollmorgen.com.

2.4.6.1 Servomotors



AKM2G



AKM



AKMH



Goldline

2.4.6.2 Cartridge Motors



Cartridge DDR

2.4.6.3 Direct Drives



Housed DDR



KBM Frameless



TBM Frameless

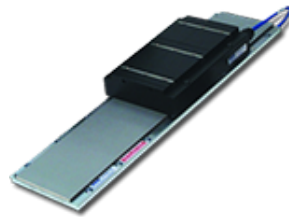

Direct Drive Linear

2.5 Different Implementations

KAS supports these architectures:

- Single-Axis with AKD PDMM (→ p. 68)
- Multi-Axis with AKD PDMM, PCMM, or PCMM2G (→ p. 69)

2.5.1 Single-Axis with AKD PDMM

The scalable system architecture begins with an integrated programmable controller and drive package to control a single axis.

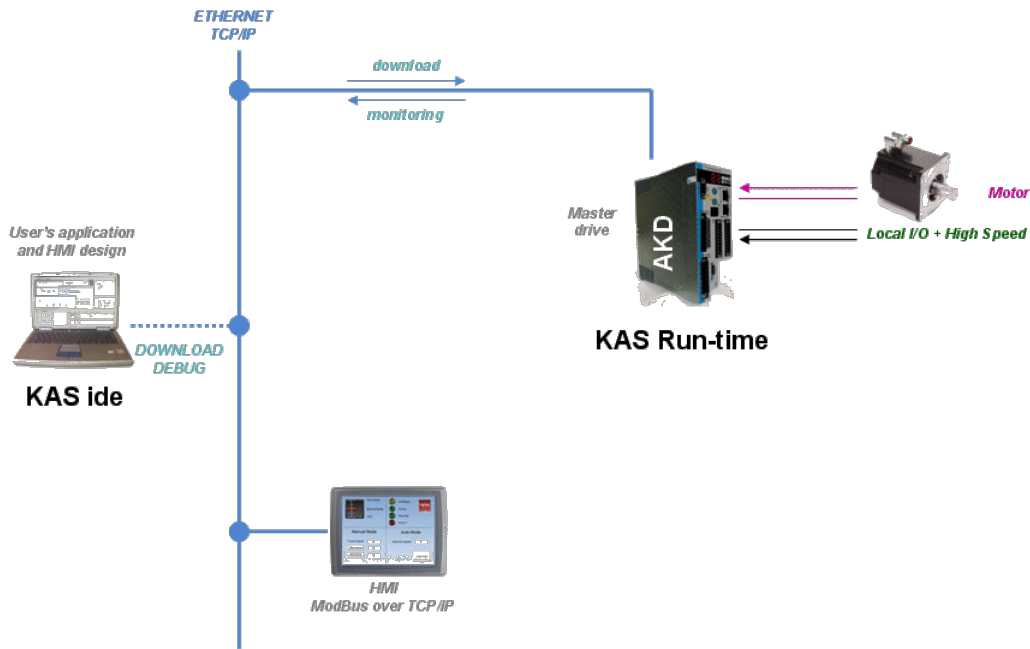

2.5.2 Multi-Axis with AKD PDMM, PCMM, or PCMM2G

The controller can be scaled to control additional drives w/ motors and I/O devices via EtherCAT.

This configuration can manage up to 32 axes.

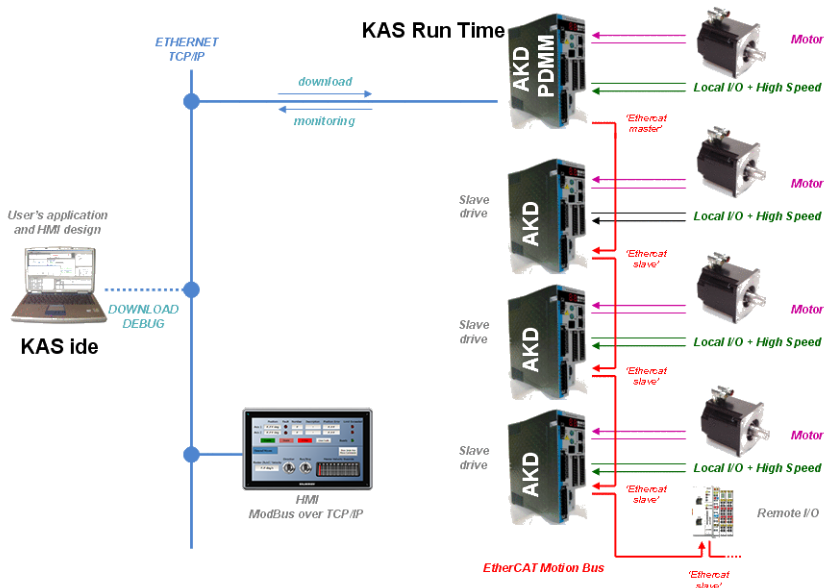

3 Describing the KAS Graphical User Interface

This section provides an overview of the common elements of the KAS-IDE GUI.

See:

- "KAS IDE Reference" (→ p. 247) for in-depth discussion of interface elements.
- "Using the KAS Simulator" (→ p. 361) for KAS Simulator GUI.
- "AKD Drive" (→ p. 122) for AKD drive GUI View.

3.1 Windows and Panels Overview

3.1.1 Main Window

The KAS-IDE interface provides an all-in-one-window integrated workspace.

The main view in the Integrated Development Environment (IDE) is a Multiple Document Interface (MDI) environment. This provides an easy-to-use and customizable view, including the ability to hide, enlarge, or overlap windows in order to optimize visibility.

The main view is saved when you exit KAS-IDE. This ensures that your workspace remains the same each time you open and use the KAS-IDE.

The KAS-IDE main window contains these items:

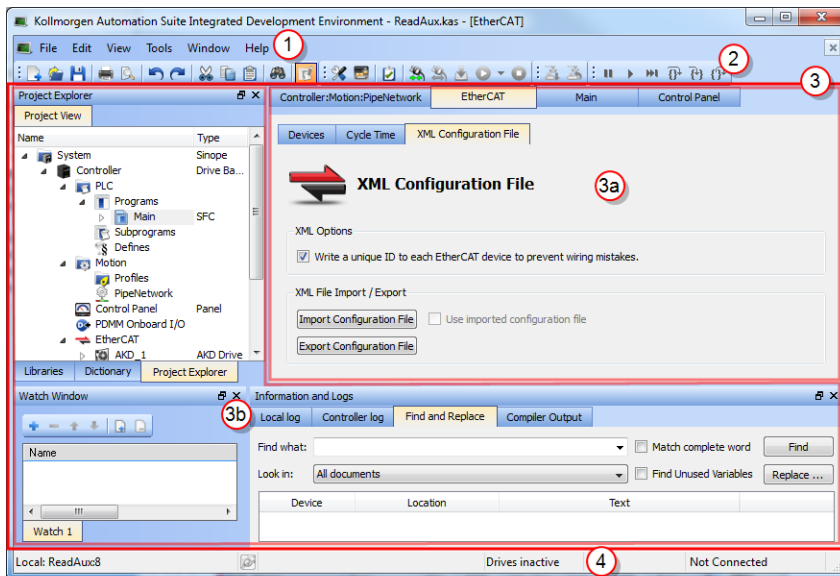

Figure 3-1: KAS Main Window

Item Number	Description
1	Menus
2	Toolbars
3	Workspace
3a	This area is specifically used for the workspace children windows.
3b	Several toolboxes A toolbox is a child window that provides some functions to perform specific tasks.
4	Status Bar - Shows the current state of the target.

3.1.2 Toolboxes

These are the available toolboxes:

- "Project Explorer" (→ p. 71)
- "Libraries" (→ p. 85)
- "Information and Logs window" (→ p. 102)

TIP

Hide or show each toolbox and toolbar directly from the contextual menus in any title bar (e.g., menu, toolbar, or toolboxes).

3.1.3 Project Explorer

The Project Explorer toolbox window displays machine application information in a tree-structure representation.

This window contains all the items used to design, implement, test, and document the application.

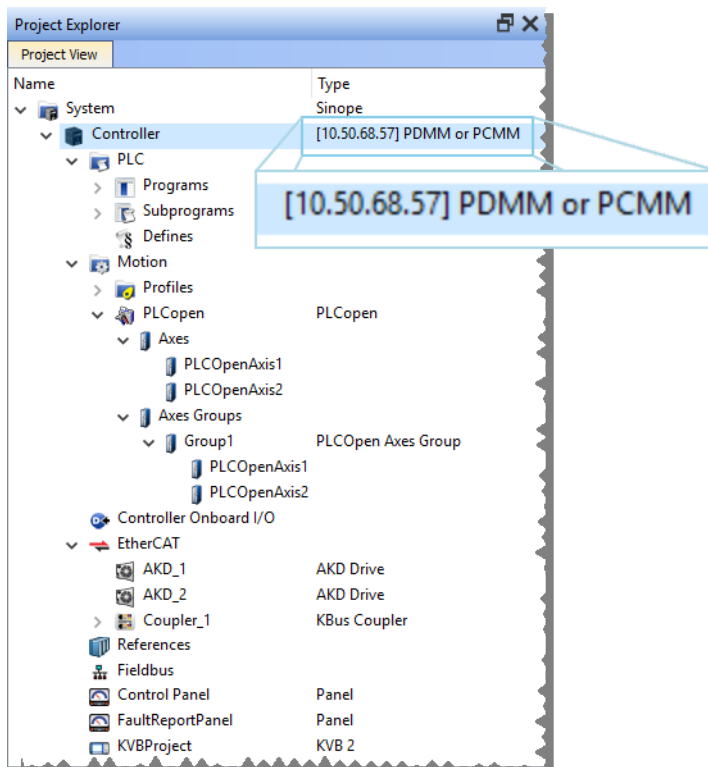

Figure 3-2: KAS Project Explorer

Item	Description
Hardware	Devices that make up the system such as Controllers, EtherCAT Motion Bus, servo and stepper drives, HMI devices, I/O Terminals, etc.
Motion	<ul style="list-style-type: none"> • Pipe Networks or PLCopen • Axis objects • Cam profiles
PLC (IEC 61131-3)	<ul style="list-style-type: none"> • Programs that control the system. • User-defined Functions and Function Blocks.

TIP

Navigate in the project-tree by entering the item's initial letter or using the arrow keys.

A project is made of these items:

- "System" (→ p. 72)
- "Controller" (→ p. 72)
 - "PLC" (→ p. 74)
 - "Programs" (→ p. 75)
 - "Subprograms" (→ p. 76)
 - "Defines" (→ p. 76)
 - "Motion" (→ p. 76)
 - "Profiles" (→ p. 76)
 - "Pipe Network" (→ p. 77) or "PLCopen" (→ p. 78)
 - "Controller Onboard I/O" (→ p. 79)
 - "EtherCAT" (→ p. 79)
 - "AKD Drive" (→ p. 80)
 - "AKT (K-Bus) I/O Coupler" (→ p. 80)
 - "Device" (→ p. 81)
 - "Module" (→ p. 81)
 - "References" (→ p. 81)
 - "Fieldbus" (→ p. 82)
 - "Control Panel" (→ p. 79)
 - "KVB Project" (→ p. 82)
 - "SafePLC2 Project" (→ p. 82)
- "HMI Device" (→ p. 82)
 - "KVB Project" (→ p. 82)

NOTE

Node Names: Allowable characters for node names include A-Z, a-z, 0-9, . (period), - (hyphen), and _ (underscore).

3.1.3.1 System

This item concerns the whole project. A right-click opens its menu that provides these options:

Command	Description
Add HMI Device	Add a new HMI device with a KVB panel. See "HMI Device" (→ p. 82).

3.1.3.2 Controller

A controller is composed of:

- a "PLC" (→ p. 74) item
- a "Motion" (→ p. 76) item
- a "Control Panel" (→ p. 79)
- an "EtherCAT" (→ p. 79) Motion Bus
- some "References" (→ p. 81)

This item displays the controller's IP address and controller hardware type.



- It is used to "Access the Web server From the KAS-IDE" (→ p. 82).
 - The webserver functionality may be used directly in the KAS-IDE.
- See "Using the KAS Web server" (→ p. 402).

NOTE

The IP address is shown as 127.0.0.1 if the system is in simulation mode.

3.1.3.3 Controller Node - Context Menu

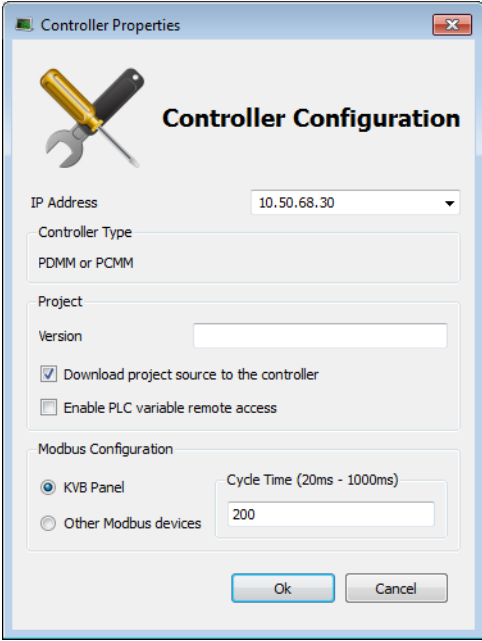
Command	Description
Add Control Panel	Add a new control panel to the controller. See "Control Panel" (→ p. 79).
Import Control Panel	Import a pre-configured control panel for use in the project. See "Import a Control Panel" (→ p. 84).
Add KVB Project	Add a new KVB panel which is embedded into the controller. See "KVB Project" (→ p. 82).
Import KVB Project	<ul style="list-style-type: none"> • Import a compressed ("zipped") KVB project, which may be created in KAS or KVB. • The system validates the compressed KVB project and adds the panel.
Add SafePLC2 Project	Add a node to the tree to access a SafePLC2 project directly from the KAS-IDE. See "SafePLC2 Projects" (→ p. 189).
Import SafePLC2 Project	<p>Select a <code>.SPL2</code> file to import.</p> <ul style="list-style-type: none"> • There may only be a single instance of a SafePLC2 project in the KAS-IDE. <ul style="list-style-type: none"> • If none exists, a SafePLC2 Project is added to the end of the Project tree. • If there is a project, you are prompted to overwrite the project or cancel the import. • The import cannot occur if SafePLC2 is running.
Add Fieldbus	Add a node to access the Fieldbus Editor.
Access Web Server	This command opens the web server interface in the GUI. See "Access the Web server From the KAS-IDE" (→ p. 82) and "Using the KAS Web server" (→ p. 402).

Command	Description
<p>Properties</p>	<p>Open a dialog box to configure the controller. See "Configure the Controller" (→ p. 135).</p>  <p>Figure 3-3: Configure the Device</p> <p>Parameters Description</p> <ul style="list-style-type: none"> • IP Address or COM: Allows for connecting to and downloading your application to the controller. Changing this value modifies the IP address for the Controller. <ul style="list-style-type: none"> • The last 10 IPs entered are accessible and are stored with the project. <ul style="list-style-type: none"> • Selecting an item in the list and pressing the 'Delete' key clears the entry from the list. • When you click  to choose the simulation mode, this address is disabled. <div style="border: 1px solid black; padding: 5px; margin: 10px 0;"> <p>⚠ IMPORTANT</p> <p>Do not use leading zeroes when entering an IP address. The connection to the controller automatically fails if leading zeroes are used. Example: Use 10.2.3.40 instead of 010.002.003.040.</p> </div> <ul style="list-style-type: none"> • The Controller type can be a AKD PDMM or PCMM. <ul style="list-style-type: none"> • See also see "Different Implementations" on page 68. • A version number is used to ensure both versions of your application on the KAS-IDE and the KAS Runtime are the same. • Enabling Download project source to the controller allows for comparing source on the controller to the source on your computer. • The Enable PLC variable remote access is disabled by default. <ul style="list-style-type: none"> • Enabling it allows users to read/write variables using an HTTP connection. • Modbus Configuration sets what the Modbus connects to. • Cycle Time specifies the update rate.

3.1.3.3.1 PLC

This item contains all the PLC (Virtual Machine) part of the controller.

These items can be present in the PLC:

- "Programs" (→ p. 75)
- "Subprograms" (→ p. 76)
- Some "Defines" (→ p. 76)

Command	Description
Libraries	Import new libraries

3.1.3.3.2 Programs

Command	Description
Cycle	Configure the cycle of the virtual machine. See "Define the PLC Cycle" (→ p. 219).
Import	Import a saved program.
New Program	Add new program items: <ul style="list-style-type: none"> • Free Form Ladder Diagram (FFLD) Editor • Function Block Diagram (FBD) • Instruction List (IL) • Sequential Function Chart (SFC) • Structured Text (ST)

TIP

Programs and Subprograms can be reordered by drag-and-drop.
Dragging an item up the list places it above the program you drop it on, while dragging down places it below.

3.1.3.3.3 Program Item - Contextual Menu

Command	Description
Add Child SFC	Add a child program to this program. <div style="border: 1px solid black; padding: 5px; margin-top: 10px;"> <p style="text-align: center;">NOTE</p> <p>This is reserved for only the first SFC program.</p> </div>
Import Child SFC	Import a saved SFC program to the current program. <div style="border: 1px solid black; padding: 5px; margin-top: 10px;"> <p style="text-align: center;">NOTE</p> <p>This is reserved for only the first SFC program.</p> </div> <p style="margin-top: 10px;">How to import all children from one project to another?</p> <ol style="list-style-type: none"> 1. Export each program one at a time from the existing project. 2. Save the program (specify a location and a name, avoiding spaces in the file name). 3. Close the project. 4. Open the project to be updated. 5. Import each saved program in the project tree. 6. Rename the program if needed. <p style="margin-left: 40px;">Only local variables are copied (not the global variables).</p>
Export	Save the selected program to your file server, avoiding spaces in the file name.
Rename	Rename the selected program.
Delete	Delete the selected program.
Print SFC and All Level 2	Print all PLC programs. See "Print" (→ p. 244).

TIP

Double-click the program name to open the program in the workspace.

3.1.3.3.4 Subprograms

Command	Description
New Function (Subprogram)	Add a new subprogram item: <ul style="list-style-type: none"> • Free Form Ladder Diagram (FFLD) Editor • Function Block Diagram (FBD) • Instruction List (IL) • Structured Text (ST)
New UDFB	Add a new UDFB item: <ul style="list-style-type: none"> • Free Form Ladder Diagram (FFLD) Editor • Function Block Diagram (FBD) • Instruction List (IL) • Structured Text (ST)
Import	Import a saved program.

3.1.3.3.5 Subprogram Item - Context Menu

You can create your own functions as well as functional blocks that are called UDFBs (User-Defined Functional Blocks).

For each of them, use these commands:

Command	Description
Export	Save the selected subprogram onto your file server.
Rename	Rename the selected subprogram.
Create Unlocked Copy	Duplicate the selected, locked subprogram. The duplicate is NOT locked.
Delete	Delete the selected subprogram.
In/Out Parameters	Open the Program Properties dialog box to "Declare Functions or Function Blocks" (→ p. 308). This item is disabled for locked UDFBs.

3.1.3.3.6 Defines

This item contains all the global definitions in the scope of the corresponding device.

See also see "Use the Defines List" on page 311.

TIP

Double-click a **Define** item to show these global definitions.

A file of internal defines are found in the installation directory of the KAS-IDE\Astrolabe\Bin\HwDef\lib.eqv.

3.1.3.3.7 Motion

The motion item contains the motion-specific items (e.g., the Profiles and Pipe Network items).

Command	Description
Motion Engines	Choose the motion engine for the application "Pipe Network or PLCopen" (→ p. 725).

3.1.3.3.8 Profiles

This item contains all the cam profiles in the project.

Command	Description
New Profile	Create a new cam profile and add it to this device (*.csv, *.cam). See "Adding Cam Profiles" (→ p. 213).
Import	Import already existing cam profiles to a project.
Show Compiled Code	Show the code corresponding to the selected cam profile.

Right-click a cam profile to use these additional commands:

Command	Description
Rename	Change the cam profile to a different name.
Delete	Remove the cam profile from the list.
Export	Save the cam profile in (.CAM) format.
Properties	Opens a dialog to modify the cam profile's Master/Input Slave/Output Offset and Scale values.

See "Adding Cam Profiles" (→ p. 213) and "Cam Profile Editor" (→ p. 444).

3.1.3.3.9 Pipe Network

This menu applies to the Pipe Network in the project.

Command	Description
Import and Replace	This command replaces the existing Pipe Network with a pre-saved Pipe Network. A dialog box opens to locate the pre-saved file. The Pipe Network Editor is opened when the file is imported.
Export	Export the Pipe Network to a file for reuse.
Show Compiled Code	Show the code corresponding to the Pipe Network.

ⓘ IMPORTANT

The existing EtherCAT axis mapping is lost when using **Import and replace**.
Profiles assigned to Cam blocks are cleared.

1. In the Project View, double-click **EtherCAT** to open the "EtherCAT Devices tab" (→ p. 322).
2. Use the tab to reassign the axes.

3. Double-click any cam of the blocks and set the **Profile_Name** parameter.

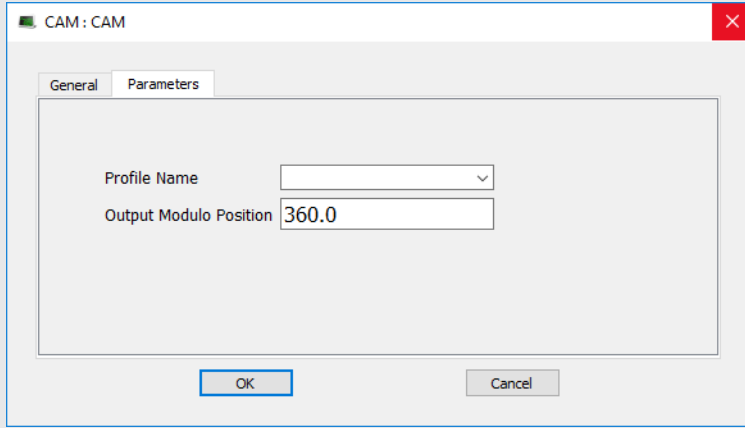

3.1.3.4 PLCopen

Command	Description
New Axis	Add a new axis to your project. See "Create a PLCopen Axis" (→ p. 166).
Show Compiled Code	Show the code corresponding to the PLCopen.

3.1.3.4.1 Axes

- Each axis is listed here, whether it is found via a scan of the EtherCAT network, or added manually.
- To add an axis manually, right-click and select **New Axis**.

For each PLCopen axis, use these commands:

Command	Description
Properties	Open a dialog box to "Modify PLCopen Axis" (→ p. 166).
Delete	Delete the selected axis.

3.1.3.4.2 Axes Groups

Axes Groups are collections of related axes defined by the data type `AXIS_GROUP_REF`.

- They are typically used by coordinated motion and function blocks such as `MC_SetKinTra`.
- Right-click in this section to create a new Axes Group.
- Groups are populated by dragging an existing axis from the above section into the group.

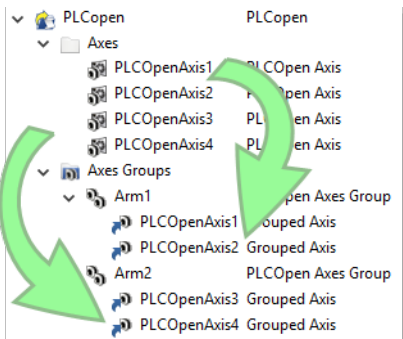

These commands are available by right-clicking on a group.

Command	Description
Delete	Delete the selected Axes Group.
Rename	Change the name of the Axes Group.

3.1.3.5 Control Panel

This holds the Control Panel item used to provide a basic interface between you and the virtual machine.

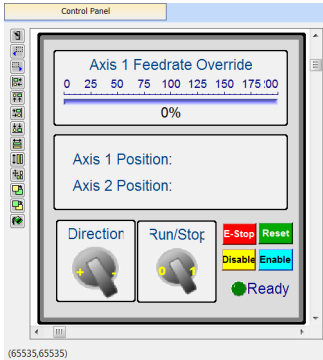

- See "Design the HMI with the Internal Editor" (→ p. 464).
- See "KVB Project" (→ p. 82) for a more advanced tool to build HMI.

Command	Description
Rename	Rename the selected Control panel.
Delete	Delete the selected Control panel.
Export	Export the control panel for use in other projects. See "Export a Control Panel" (→ p. 83).

3.1.3.5.1 Controller Onboard I/O

Command	Description
Properties	Open the Properties dialog box to configure the local I/O for the AKD PDMM or PCMM controller. See "Controller Onboard I/O" (→ p. 398).

3.1.3.5.2 EtherCAT

This item gives access to all the devices linked to the EtherCAT Motion Bus.

Command	Description
Add Device...	In the Project view, add a Kollmorgen drive, power supply, or coupler, per a third-party EtherCAT device to the EtherCAT node.
Scan Devices	TheKAS Runtime sends EtherCAT messages to discover the devices present in the network. See "EtherCAT Devices tab" (→ p. 322).
Enable/Disable Online Configuration Mode	Toggles Online Configuration Mode on and off. See "Online Configuration Mode" (→ p. 255).
Properties	Opens the Properties dialog box. See "Configure EtherCAT Motion Bus" (→ p. 138).

See "Add and Configure Third Party Devices" (→ p. 204).

3.1.3.5.3 AKD2G Drive

Double-click an AKD2G to set its parameters.

See "Configure the AKD / AKD2G Drive" (→ p. 191).

Command	Description
Rename	Rename the selected drive.
Delete	Delete the selected drive.
Configuration	Opens the Configuration tab for the AKD GUI.
Properties	Select the Properties menu to access the EtherCAT device's configuration views.

3.1.3.5.4 AKD Drive

Double-click an AKD to set its parameters.

See "Configure the AKD / AKD2G Drive" (→ p. 191).

Command	Description
Rename	Rename the selected drive.
Delete	Delete the selected drive.
Configuration	Opens the Configuration tab for the AKD GUI.
Properties	Select the Properties menu to access the EtherCAT device's configuration views.

3.1.3.5.5 AKD-C Central Power Supply

Double-click an AKD-C to set its parameters.

See "Configure the AKD / AKD2G Drive" (→ p. 191).

Command	Description
Rename	Rename the selected device.
Delete	Delete the selected device.
Properties	Select the Properties menu to access the EtherCAT device's configuration views.
Configuration	Opens the Configuration tab for the AKD GUI.

3.1.3.5.6 AKD-N Drive

Double-click an AKD-N to set its parameters.

See "Configure the AKD / AKD2G Drive" (→ p. 191).

Command	Description
Rename	Rename the selected drive.
Delete	Delete the selected drive.
Properties	Select the Properties menu to access the EtherCAT device's configuration views.
Configuration	Opens the Configuration tab for the AKD GUI.

3.1.3.5.7 AKT (K-Bus) I/O Coupler

The Standard I/O Coupler node gives access to its I/O slices.

Command	Description
Add I/O Slice	Add a new slice (Digital or Analog Input and Output) to the selected Standard I/O Coupler.
Rename	Rename the selected coupler.
Delete	Delete the selected coupler.
Properties	Select the Properties menu to access the EtherCAT device's configuration views.

NOTE

These commands are disabled when the controller is running.
See "Troubleshooting" (→ p. 823) about diagnosing the coupler LEDs.

3.1.3.5.8 AKT2G (EtherCAT) I/O Coupler

The Coupler node acts as a gateway for E-Bus I/O slices.

Command	Description
Rename	Rename the selected coupler.
Delete	Delete the selected coupler.
Properties	Select the Properties menu to access the EtherCAT device's configuration views.

NOTE

These commands are disabled when the controller is running.
See "Remote Input/Output Terminals" (→ p. 697).

3.1.3.5.9 I/O Slice

- AKT (K-Bus) slices are children of the AKT I/O Coupler.
- AKT2G (E-Bus) slices are children of the EtherCAT node.

Command	Description
Rename	Rename the selected slice.
Delete	Delete the selected slice.
Properties	Open the Properties dialog box to configure the I/O slice. See "Map Input and Output to Variables" (→ p. 314).

3.1.3.5.10.1 Device

Double-click a Device to access its EtherCAT device configuration views.

Command	Description
Rename	Rename the selected device
Delete	Delete the selected device
Add Module...	Add a module to an MDP device. See "Add Modules to Third Party EtherCAT Devices" (→ p. 206).
Properties	Access the EtherCAT device's configuration views.

3.1.3.5.11 Module

Command	Description
Rename	Rename the selected module.
Delete	Delete the selected module.

3.1.3.6 References

Used to **insert references** into a project.

Each reference is a user-defined reference that links any kind of deliverable to your project.

See "Use the Reference Folder" (→ p. 246).

Command	Description
Insert Reference	Link any kind of deliverable to your current project.
Delete	Delete the reference.
Properties	Open the referenced file in the workspace.

3.1.3.6.1 Fieldbus

This item holds the Fieldbus Editor to configure the Ethernet/IP or Profinet fieldbuses.

See "Fieldbus Editor" (→ p. 585).

3.1.3.7 HMI Device

This item holds the HMI (Human Machine Interface) item used to provide an advanced interface between you and the virtual machine.

Command	Description
Add KVB Project	Add a new KVB panel to the controller. See "HMI" (→ p. 696). See "Add an HMI Device" (→ p. 185) for mode details. This command is disabled when a KVB panel already exists.
Import KVB Project	<ul style="list-style-type: none"> Import a compressed ("zipped") KVB project, which may be created in KAS or KVB. The system validates the compressed KVB project and adds the panel.
Rename	Rename the selected HMI device.
Delete	Delete the selected HMI device.

3.1.3.7.1 KVB Project

Command	Description
Open KVB	Opens the associated KVB project.
Rename	Rename the selected KVB panel.
Delete	Delete the selected KVB panel.
Export	Save a copy of the panel in a compressed (.ZIP) file.

3.1.3.8 SafePLC2 Project

Command	Description
Delete	Delete the SafePLC2 project.
Export	Select a location and name to export / create a SafePLC2 file.
Open SafePLC2	Creates or opens a synchronized SafePLC2 project. See "SafePLC2 Projects" (→ p. 189).
Rename	Rename the SafePLC2 project.

3.1.3.8.1 Access the Web server From the KAS-IDE

Double-clicking **Controller** will both expand/collapse the controller's components as well as open the web server and automatically log into the *administrator* account. For more information on using the webserver see "Using the KAS Web server" (→ p. 402).

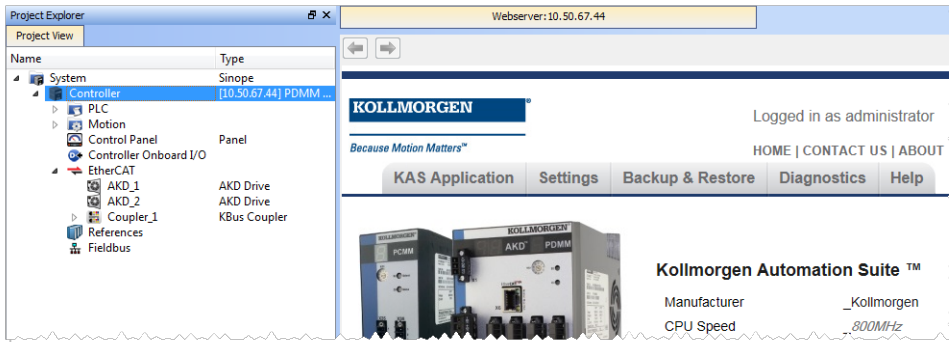

The web server can also be accessed by right-clicking the Controller node and selecting **Access webserver**.

TIP

IDE users are considered administrators and therefore are automatically logged into the webserver. You may change the password but there is no logout function.

By default the localhost (127.0.0.1) will be opened. To set the IP address of the controller, right click and select Properties. Enter the proper **Address** and **Controller type** then click **OK**. The page is automatically refreshed.

If an invalid or wrong IP address is entered, the following error will be displayed.

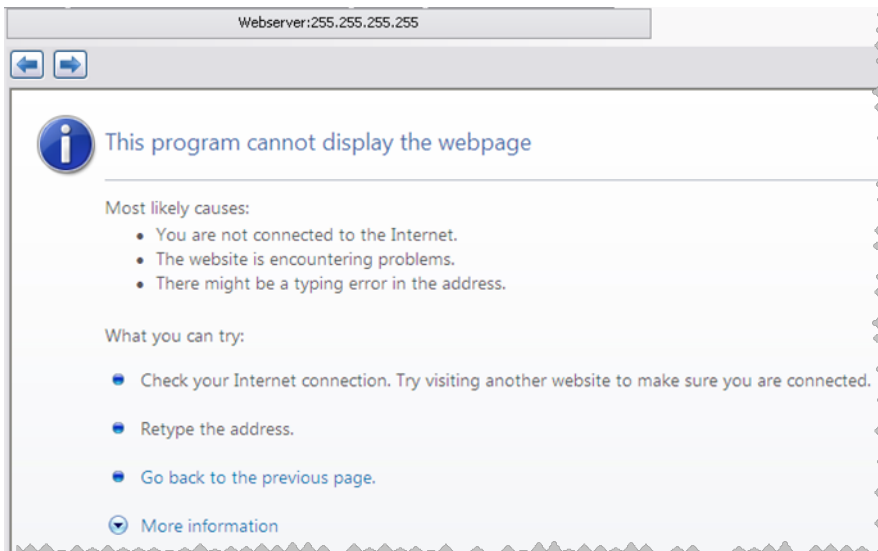

3.1.3.8.2.1 Export a Control Panel

Control Panels may be exported and imported for easy reuse across projects. Any variables associated with the control panel will be preserved across projects.

1. Right-click on the Control Panel in the Project Tree and select **Export**.

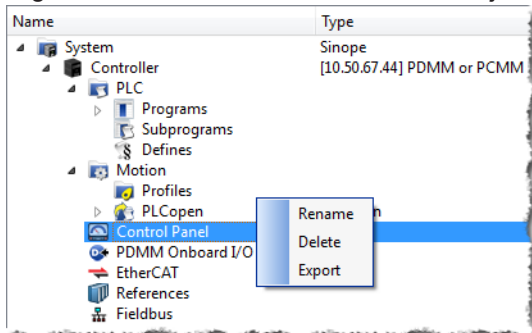

2. Name and save the .GRA file.

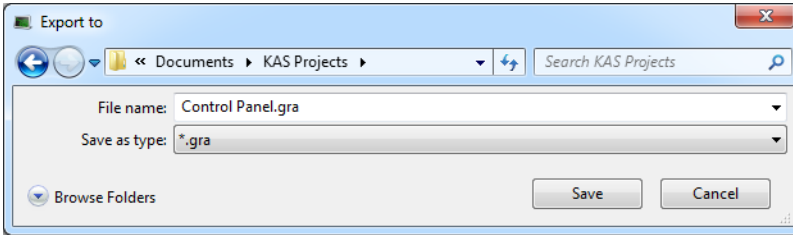

3. Click OK to confirm the export.

See also: "Import a Control Panel" (→ p. 84)

3.1.3.8.3.2 Import a Control Panel

Control Panels may be exported and imported for easy reuse across projects. Any variables associated with the control panel will be preserved across projects.

1. Right-click on **Controller** in the Project View and select **Import Control Panel**.

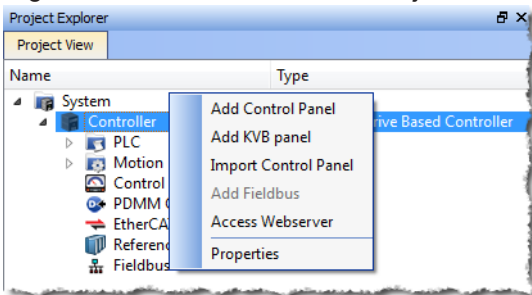

2. Locate a saved .GRA file and click **Open**.

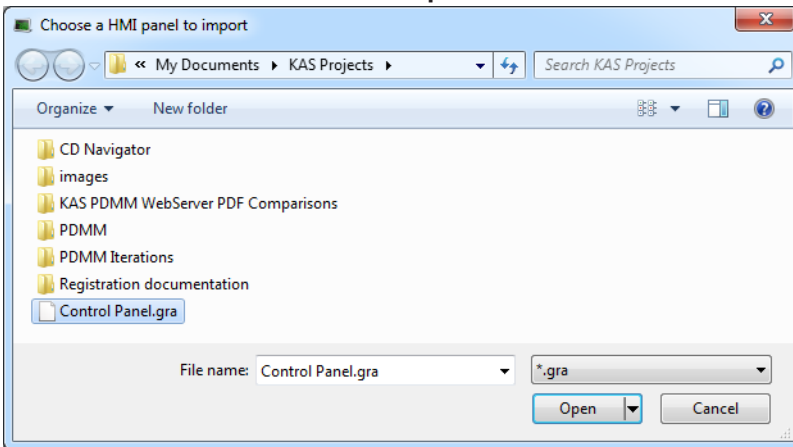

- If the panel you are trying to import has the same name as an existing panel, you will be prompted to change the name or cancel the import.

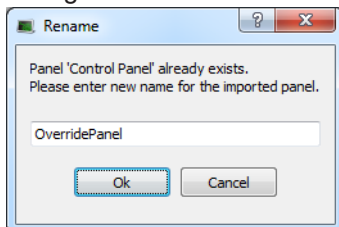

3. Upon clicking **Open** (or **OK**) the panel will be placed in the Project View.

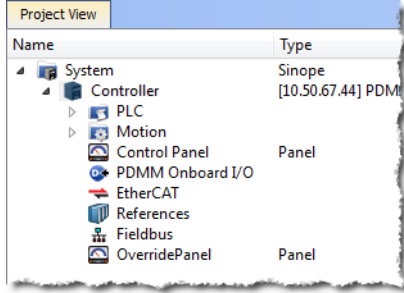

See also: "Export a Control Panel" (→ p. 83)

3.1.4 Libraries

This toolbox contains several tabs to access all the functions of the available libraries.

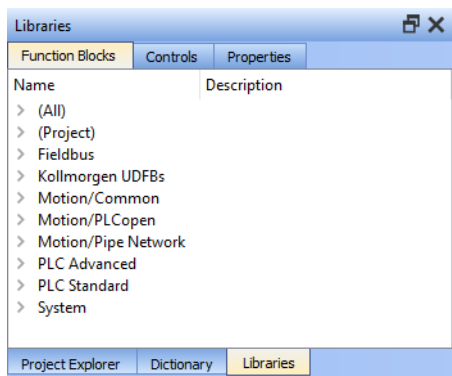

3.1.4.1 Function Blocks

This tab displays all the available libraries shown in a tree-structure representation and grouped by categories. Expand a library to access all its functions. A short description of each function is also available.

The **(All)** category at the top enables you to see the full list of available functions sorted in alphabetical order. The **(Project)** node contains all the UDFB and subprograms associated to the current project.

For more details about these libraries, see these library descriptions:

- Fieldbus Library
- Kollmorgen UDFBs
- Motion Library - Pipe Network
- Motion Library - PLCopen
- PLC Advanced Libraries
- PLC Standard Libraries
- System Library

TIP

It is possible to use the functions, UDFB or subprograms in PLC editors with a simple drag-and-drop operation.

NOTE

Dragging and dropping a Kollmorgen UDFB into the "Defines" editor has no effect. However, if the Kollmorgen UDFB is already imported to the project, then its prototype are seen in the editor.

3.1.4.2 Controls

This tab displays all the controls available for the HMI design. See "Graphic Objects" (→ p. 467).

3.1.4.3 Properties

This tab displays all the properties of an HMI control currently selected in the HMI editor.
See (→ # 474, Graphic Objects Properties) to set the properties of an HMI widget.

3.1.5 Dictionary

The Dictionary toolbox is used to show all the identifiers (i.e., variables, data types, sub-routines, etc.) defined in the project. These are the tabs in the Dictionary:

- "Variables tab" (→ p. 86)
- "Enum tab" (→ p. 99)
- "Bit Fields tab" (→ p. 100)

3.1.5.1 Variables tab

The Variables tab is used to show all the variables defined in the project. All the variable details are displayed in order to show the variable types, dimensions, attributes, etc.

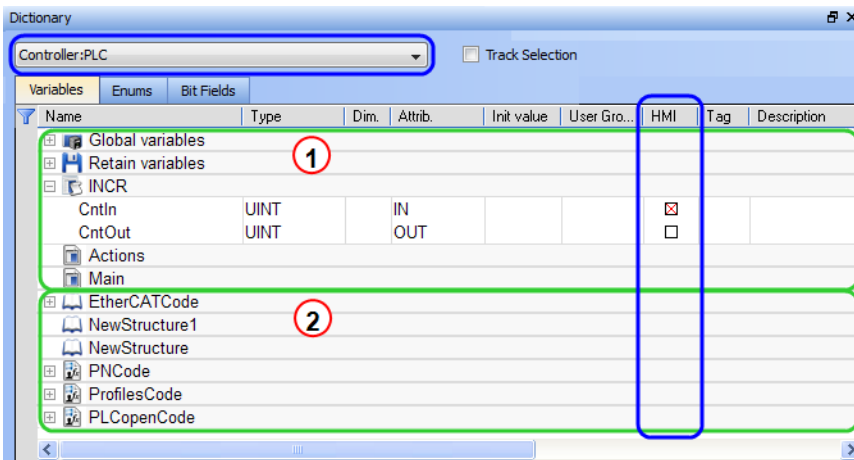

Figure 3-4: Variables tab

The list of variables is split into two parts:

Item Number	Description
1	All the Variables at the top.
2	All the Structures at the bottom.

NOTE

See "Call Functions or Function Blocks" (→ p. 311) about the procedure to create an instance of a structure.

TIP

To show all the variables of all programs, select 'PLC' in the project tree.

The Dictionary's Context Menu

Right-click in the Dictionary window to open the menu:

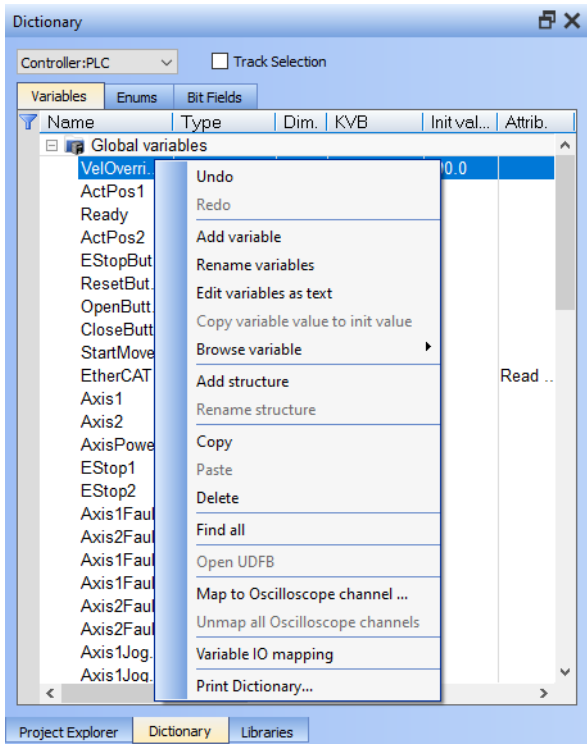

This menu is used to perform these actions:

Command	Description
Undo	Undo the last action performed on the Dictionary.
Redo	Redo the last undone action.
Add Variable	<p>Add a new variable in the selected level (e.g., Global, Retain, program).</p> <ul style="list-style-type: none"> • This automatically creates a new variable called NewVar with type BOOL. • For a Function or UDFB, you can specify input and output parameters. • See "Define Parameters and Private Variables" (→ p. 310).
Rename variables	<p>Used to either replace a section of matching variables or append text to the variable's names.</p> <p>See "Rename Variables" (→ p. 95).</p>
Edit variables as text	<p>Opens a text editing dialog used to edit the variables found in the group as text using IEC 61131-3 syntax.</p> <p>See "Edit Variables as Text" (→ p. 307).</p>
Copy variable value to init value	<p>Copies the current value of a retain variable to the variable's initial value.</p> <p>See "Copy a Retained Variable Value to Init Value" (→ p. 708).</p>
Browse variable	<p>Used to browse all instances of a variable.</p> <p>See "Browse Variable tab" (→ p. 112).</p>
Add Structure	<p>Used to add a new complex type.</p> <p>A structure named NewStructure is created and variables can be dragged into it.</p> <p>See "Complex Structures" (→ p. 305).</p>
Rename Structure	Used to rename the selected structure.

Command	Description
Copy	Used to copy a variable.
Paste	Used to paste the copied variable to the selected level.
Delete	Used to delete the selected variable. Press <Delete> on the keyboard.
Find all	Used to find all instances of the specified variable and opens the results in the Find and Replace tab.
Open UDFB	Used to open the selected UDFB instance. See "Monitoring UDFBs" (→ p. 241).
Map to Oscilloscope channel ...	Used to plug the selected variable on a channel. <ul style="list-style-type: none"> This command opens a dialog used to configure the variable plug operation. This command is enabled when the application is connected and running, and if the "Data Types" (→ p. 702) of variable is eligible for the Softscope as long as they are not in a UDFB instance: <ul style="list-style-type: none"> Data Types: BOOL, BYTE, DINT, DWORD, INT, LINT, LREAL, LWORD, SINT, TIME, UDINT, UINT, ULINT, USINT, WORD.
Unmap all Oscilloscope Channels	Used to unplug all plugged probes from the Softscope.
Variable I/O mapping	Used to connect a variable to an I/O.
Print Dictionary ...	Used to print all the variables displayed in the Dictionary and sorted by programs. The columns show the Name, Type, Dimension, Initial Value, and Attributes.

Name	Type	Dim	InitVal	R	E
(Global)					
TravelSpeed	LREAL	0	LREAL#0		
MasterAbsPos	LREAL	0	LREAL#0		
MasterDeltaPos	LREAL	0	LREAL#90		
MachineSpeed	LREAL	0	LREAL#0		
Axis1Status	DINT	0			
Axis2Status	DINT	0			
MachineState	DINT	0 0			
bMasterAbs	BOOL	0	FALSE		
bMasterRel	BOOL	0	FALSE		
bEStop	BOOL	0	FALSE		
bLedStatus	BOOL	4			
Profiles	ProfilesCode	0			
EtherCAT	EtherCATCode	0			R
PipeNetwork	PNCCode	0			
(Retain)					
LastAxisPos	LREAL	0			
MachineLogic					
lastTravelSpeed	LREAL	0	LREAL#0		
lastMachineSpeed	LREAL	0	LREAL#0		
ProfilesCode					
cmdID	DINT	0			
PNCCode					
cmdID	DINT	0			
MASTER	DINT	0			
GEAR1	DINT	0			
CNV1	DINT	0			
AXIS1	DINT	0			
GEAR2	DINT	0			
CNV2	DINT	0			
AXIS2	DINT	0			
PipeAXIS1	DINT	0			
PipeAXIS2	DINT	0			

What is the purpose of the Track Selection check box?

The **Track Selection** filters the displayed items in the dictionary to show only items linked to the current PLC selected program:

- **Unchecked:** All project variables are displayed. This is the default setting.
- **Selected:** The variables in the Dictionary are filtered to show only those relevant to the PLC item currently selected in the project tree.
 - Along with the Global, retains and variables related to the selected program or UDFB, structure definitions are shown.
 - The dictionary content changes accordingly if another PLC program is selected in the project tree.

The two editing modes for editing a variable.

There are two modes when editing a variable in the Dictionary:

- **Cell:** Only the selected cell is active.

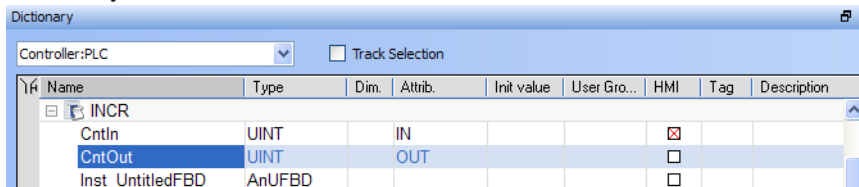

- **Row:** The entire row is active.

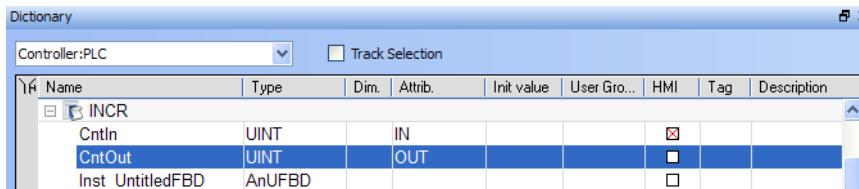

Press the Spacebar to toggle the selection mode from cell to row.

See "Table Keyboard Shortcuts" (→ p. 268).

How can variables be arranged and/or sorted?

- The columns in the Variables tab can be reordered, resized, and hidden by double clicking on the filter icon in top left corner of the table.
 - This opens a dialog box used to modify the table's appearance.
 - These settings persist until you change them.
 - The Visible box for the Value field cannot be changed because the Value column is automatically shown in debug and online modes but hidden in edit mode.

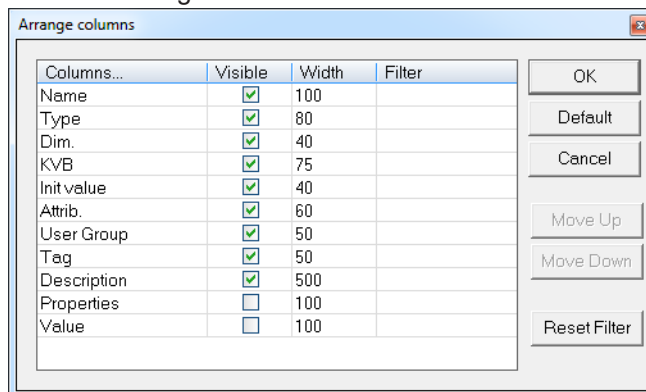

- Sort the list of variables in the table by either:
 - Verify you are in **cell** editing mode (press the **Spacebar** to toggle from one mode to the other).
 - Click the header of the column to use as the key sort order.

Modify Parameters of a Variable

Press the **Spacebar** to toggle to the relevant edition mode.

Mode	Description
One Parameter	In the cell edition mode, double-click on the parameter.
All the parameters are at the same time	In the row edition mode, double-click in any parameter to open the dialog box for variable configuration. See "Variables" (→ p. 90) about parameters.

NOTE
A variable cannot be changed when the KAS-IDE is connected to the controller.

3.1.5.1.1 Variables

All **variables** in the entire project are grouped by:

Variable	Description
Global Variables	List all global variables used and accessible throughout the entire program.
Program Variables	List the variables related to your specific selected program.
"Retain Variables" (→ p. 707)	List all variables to be retained when the system is powered down.

For each variable, the Dictionary toolbox allows you to set these parameters:

Field	Description
Attributes	The variable attributes are Read-only, External, IN, OUT. <ul style="list-style-type: none"> • Read-only: A variable set as Read Only is a constant. <ul style="list-style-type: none"> • It cannot be modified in the PLC code, but it can be manually forced. <ul style="list-style-type: none"> • See "Force a Variable" (→ p. 120) for more information. • Read-only variables can be mapped to Inputs but not to Outputs. <ul style="list-style-type: none"> • Inputs can change state and a Read-only variable cannot change its value to match the input state. • External: this attribute is not used. • IN or OUT: Input or Output parameters of User Defined Function Blocks
Description	The variable description is a long comment text that describes the variable.
Dim.	To declare an array, specify dimensions for an internal variable. See "Arrays" (→ p. 703) for more information.
HMI	Select variables to be used in HMI. See "Map Variables to HMI" (→ p. 186) for more information.
Init value	The variable initial value when you start your application. See "Variable Initial Value" (→ p. 97) for more information.
Name	The variable name.
Syb.	Reserved.

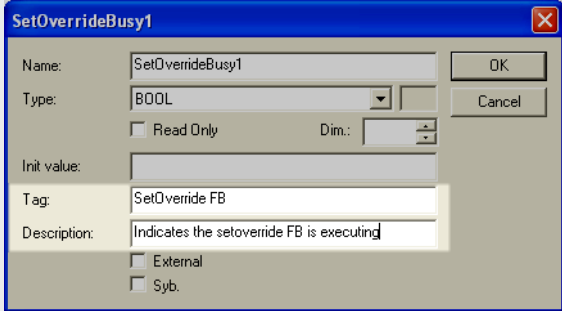
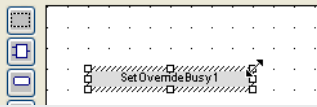
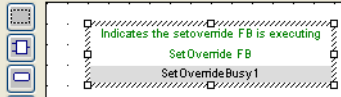
Field	Description
Tag	<p>The variable tag is a short comment, that can be displayed together with the variable name in graphical editors.</p> <p>Edit the variable parameters.</p>  <p>Add the variable to your FBD program.</p> <p><input type="radio"/> ST/IL <input checked="" type="radio"/> FBD <input type="radio"/> FFLD</p>  <p>Resize the rectangle to make the Tag and Description visible.</p> <p><input type="radio"/> ST/IL <input checked="" type="radio"/> FBD <input type="radio"/> FFLD</p> 
Type	The variable type (can also be UDFB or complex structure). See "Data Types" (→ p. 702) for more information.
User Group	The variable user group (used for sorting variables).
Value	<p>All the variables in the Dictionary are animated with real-time values ¹</p> <ul style="list-style-type: none"> • This column is only displayed when your application is running. • See "Variable Monitoring" (→ p. 241) for more information.

3.1.5.1.2 Structures

All the **structures** within the entire system project are grouped as follows:

¹To better track variables in Running mode, the KAS-IDE dynamically computes their value along with the application execution and display the result in this column.

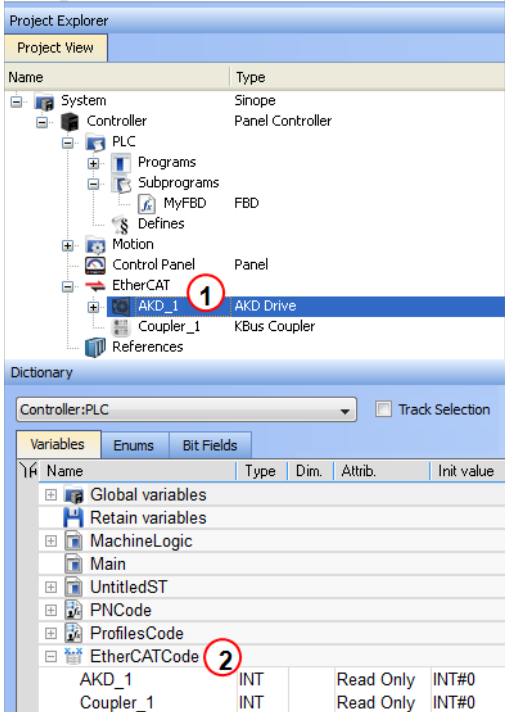
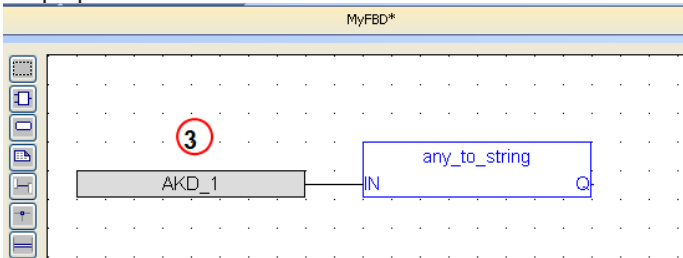
Structure	Description															
EtherCATCode	<p>List all the devices as PLC variables so you can use their names in FBS instance</p> <ul style="list-style-type: none"> The devices are displayed under the EtherCAT node in the Project Explorer (see call out 1) The same devices are also displayed as PLC variables in the Dictionary 2  <p>The screenshot shows the Project Explorer on the left with the 'EtherCAT' node expanded, listing 'AKD_1' (AKD Drive) and 'Coupler_1' (KBus Coupler). The Dictionary on the right shows the 'EtherCATCode' section with a table of variables:</p> <table border="1"> <thead> <tr> <th>Name</th> <th>Type</th> <th>Dim.</th> <th>Attrib.</th> <th>Init value</th> </tr> </thead> <tbody> <tr> <td>AKD_1</td> <td>INT</td> <td></td> <td>Read Only</td> <td>INT#0</td> </tr> <tr> <td>Coupler_1</td> <td>INT</td> <td></td> <td>Read Only</td> <td>INT#0</td> </tr> </tbody> </table> <ul style="list-style-type: none"> You can use them in your PLC programs with a drag-and-drop operation 3  <p>The screenshot shows a ladder logic network with a function block 'any_to_string' receiving 'AKD_1' as input.</p>	Name	Type	Dim.	Attrib.	Init value	AKD_1	INT		Read Only	INT#0	Coupler_1	INT		Read Only	INT#0
Name	Type	Dim.	Attrib.	Init value												
AKD_1	INT		Read Only	INT#0												
Coupler_1	INT		Read Only	INT#0												
PNCCode	List all the variables related to the specific Pipe Network Code															
ProfilesCode	List all the variables related to the specific profiles															
PLCopenCode	List all the variables related to the specific PLCopen Code															
UDFB variables	List the variables related to a specific UDFB															

3.1.5.1.3 Variable Editor

Variables are declared in the Dictionary of the KAS-IDE main window.

The variable editor is a table used to declare all variables of the application.

Variables in the editor are sorted by groups:

- Global variables
- Retain non-volatile global variables
- I/O variables
 - Each I/O device is a group
- Variables local to a program
 - Including in and out parameters in case of a UDFB.
- See the description of "Variables" (→ p. 705) in the language reference for a more detailed overview.

Each group is marked with a gray header in the variable list.

The – or + icon on the left of the group header is used to expand or collapse the group:

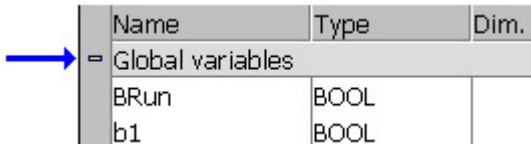

Name	Type	Dim.
- Global variables		
BRun	BOOL	
b1	BOOL	

See how to:

- "Create a New Variable" (→ p. 93).
- Use the "Variable Table List" (→ p. 93).
- "Define Structures" (→ p. 94).
- Set "Bookmarks" (→ p. 269).

3.1.5.1.4.1 Create a New Variable

Click the **INSERT** key in the variable editor to create a new variable in the selected group.

The variable is added at the end of the group. Variables are created with a default name. You can rename a new variable or change its attribute by using the [Variable Editor](#).

NOTE

You cannot insert a new variable in an I/O group.

In case of a group corresponding to local variables of a UDFB, clicking the **INSERT** key gives you the choice between:

- Add an IN (input) parameter.
- Add an OUT (output) parameter.
- Add a private variable.

IN and OUT parameters always appear at the beginning of a UDFB group.

3.1.5.1.5 Variable Table List

There are two modes when editing a variable in the Dictionary:

- **Cell:** Only the selected cell is active.

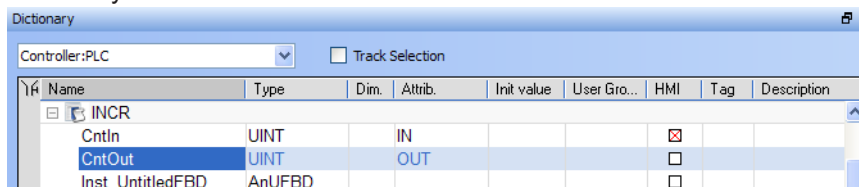

Name	Type	Dim.	Attrib.	Init value	User Gro...	HMI	Tag	Description
[-] INCR								
CntIn	UINT		IN			<input checked="" type="checkbox"/>		
CntOut	UINT		OUT			<input type="checkbox"/>		
Inst_UntitledFBD	AnUFBD					<input type="checkbox"/>		

- **Row:** The entire row is active.

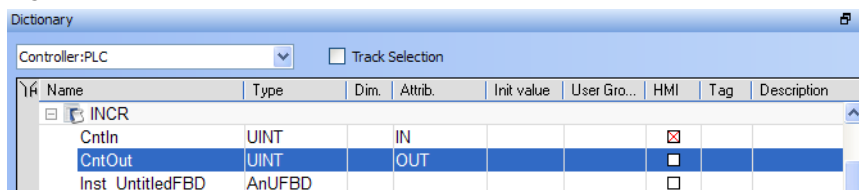

Name	Type	Dim.	Attrib.	Init value	User Gro...	HMI	Tag	Description
[-] INCR								
CntIn	UINT		IN			<input checked="" type="checkbox"/>		
CntOut	UINT		OUT			<input type="checkbox"/>		
Inst_UntitledFBD	AnUFBD					<input type="checkbox"/>		

Press the Spacebar to toggle the selection mode from cell to row.

See "Table Keyboard Shortcuts" (→ p. 268).

When the selection mode is on cell, the variable editor enables you to enter each piece of information directly in the cell.

Double-click or press ENTER to open the dialog box.

Use the mouse to drag the column separators in the main table header to resize the column widths.

Press these keys for browsing groups of variables:

Shortcut	Description
Ctrl + Page Up	Move the selection to the head of the previous group.
Ctrl + Page Down	Move the selection to the head of the following group.

For Table manipulation, see (→ # 259, Windows Standard Conventions).

3.1.5.1.6 Sort Variables

You can sort variables of a group according to their name, type, or dimension.

1. Move the cursor to the header of the group.
2. Click the name of the column to sort.
 - The KAS-IDE always keeps the original order of declared variables.
 - This allows safe online change.
 - Each time a new variable is inserted or expanded / collapsed in a group, the original sorting is re-applied.

3.1.5.1.7 Define Structures

To create a new type of data structure, use the **Add structure** command.

For more details of the full procedure, see (→ # 305, Complex Structures).

- Each structure is represented as a group in the dictionary grid.
 - Enter the members of the structure in its group in the same way variables are entered in another group.
- New data structures are created with default names.
 - Use the **Rename structure** command to change its name.
- If a member of a structure is an instance of another structure, the nested structure must be declared BEFORE in the list.

3.1.5.1.8 Name a Variable

Use this procedure to change the name of the variable:

1. In the **Name** column of the [table](#), select the cell to edit.
2. Press ENTER (or press the first character of the new name).
3. Enter the name in the small box.
4. Press ENTER to validate the name or ESCAPE to cancel the change.

A variable must be identified by a unique name within its parent group.

- The variable name cannot:
 - be a reserved keyword of the programming languages.
 - have the same name as a standard or C function or function block.
- A variable must not have the same name as a program or a user-defined function block.
- The name of a variable must begin by a letter or an underscore (_), followed by letters, digits, or underscore marks.
 - Two consecutive underscores in a variable name is not allowed.
- Naming is case-insensitive.
 - Two names with different cases are considered as the same.

3.1.5.1.9.1 Name Physical I/Os

Each I/O channel has a predefined symbol that reflects its physical location.

- This symbol begins with:
 - %I for an input.
 - %Q for an output.
 - The symbol is followed by a letter identifying the physical size of the data.
 - See "Variables" (→ p. 705) for more information.

3.1.5.1.10.2 Change the Name of an I/O Variable

You cannot change the %... name of an I/O variable.

- This name is directly allocated according to the I/O devices defined in the I/O device list.
- You can give an alias (a readable name) to each I/O channel.
 - In that case, either the % name or the alias can be used in programs.
 - The alias must fit to the same rules as a variable name.
 - When an alias is defined for a variable, both %... name and alias are shown in the **Name** column of the grid.

3.1.5.1.11 Rename Variables

Variables may be renamed from within the Dictionary. The renaming function can either replace a section of the name or append text to variable names. The search will find and replace matches first within the Dictionary and will then continue the search within programs in the current project. You will have the option to propagate the changes to programs or not.

1. Right-click on any variable in the Dictionary and select **Rename Variables**.

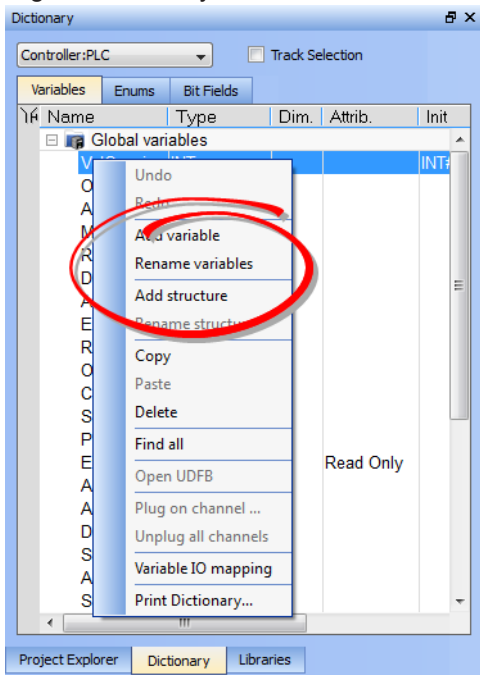

2. Enter the phrase to be replaced in **What**.
3. Enter the new phrase in **Replace**.
4. Set the replacement method using the **Where** menu.
5. Click OK to make the changes shown in the **Results** frame.
6. The **Replace in files** dialog box opens if there are matches within programs. Select which programs to modify.

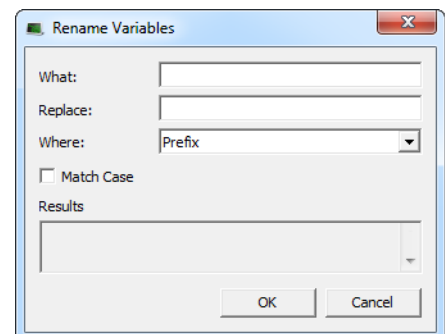

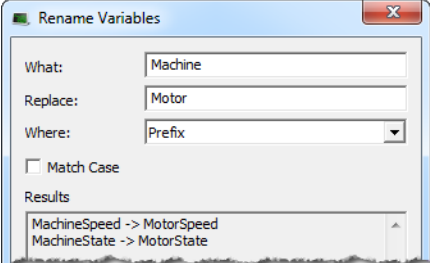
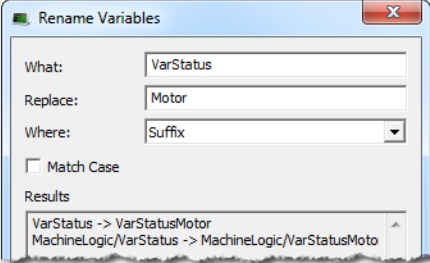
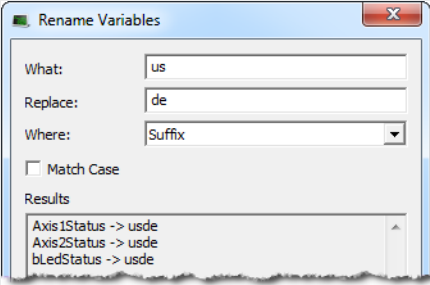
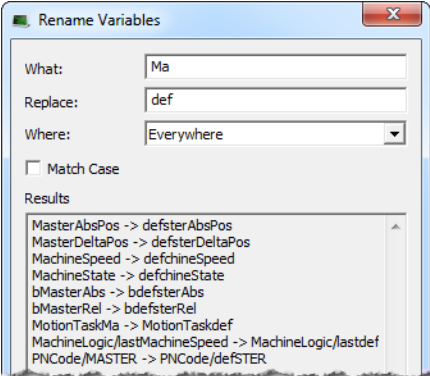
Item	What it means
What	Enter the variable name/text which is to be replaced
Replace	New text which will replace current variable name text
Where	<p>How the replace will occurs</p> <p>Prefix The search/replace starts from the first character in the variable name.</p>  <p>Suffix The "Replace" text will be appended to the "What" text, completely replacing any matches.</p>  <p>Please be aware that this search method completely replaces the search string. Use this method with caution.</p>  <p>Everywhere Searches the entire variable name.</p> 
Match Case	The search will be case sensitive
Results	The search results and proposed changes are displayed.

When matches exist within programs the **Replace in Files** dialog box displays the matches and lets you choose which programs to modify. Once **OK** is clicked, the programs will be modified in the order they appear in the list.



3.1.5.1.12 Variable Initial Value

A variable can have an initial value.

- The value must have valid "Constant Expressions" (→ p. 710) that fits to the "Data Types" (→ p. 702) of the variable.
- The initial value is displayed in **red** if it is not a valid expression for the selected data type.
- There is no initial value for arrays and instances of function blocks.
- Change the initial value of a variable using the "Variables tab" (→ p. 86).

NOTE

A retained variable's value may be assigned to the variable's initial value. See "Copy a Retained Variable Value to Init Value" (→ p. 708) for more information.

3.1.5.1.13 Variable Tag and Description

For each variable, the KAS-IDE enables you to enter in the dictionary two strings that describe the variable:

- The **Tag** is a short comment, that can be displayed together with the variable name in graphic languages.
- The **Description** is a long comment text that describes the variable.

3.1.5.1.14.1 Change the Tag or Description of a Variable

1. Enable the modification mode to **Row**.
See "Variable Table List" (→ p. 93) for more information.
2. Move the cursor to the corresponding cell.
3. Press <Enter> to save the new text.

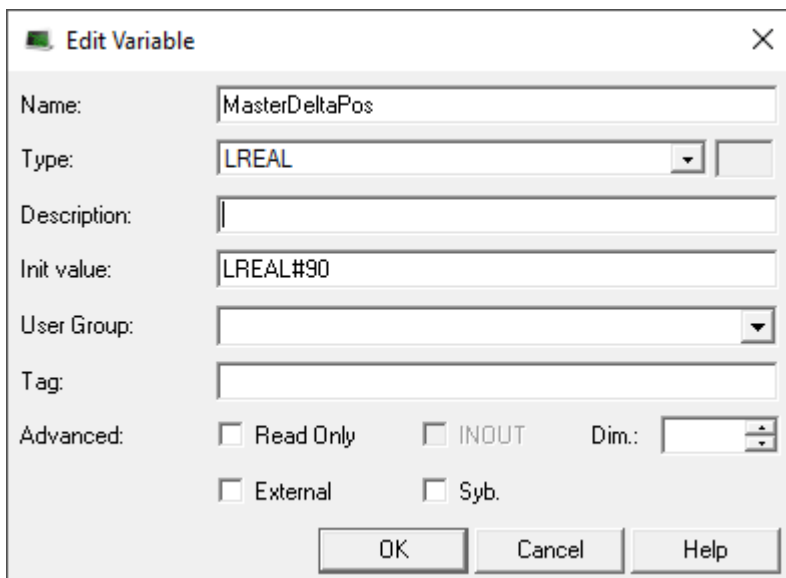

3.1.5.1.15 Edit Variables as Text using IEC 61131-3 Syntax

Using IEC 61131-3 syntax, variables are declared within structured blocks.

Each block begins with `VAR`, `VAR_INPUT`, `VAR_OUTPUT`, or `VAR_EXTERNAL` keyword and ending with `END_VAR` keyword (with no semicolon after).

This table provides the meaning of each keyword:

Keyword	Meaning
<code>VAR</code>	Memory variables. Can be global, local, or retain depending on the edited group.
<code>VAR_EXTERNAL</code>	External variables. Can be global or local depending on the edited group.
<code>VAR_INPUT</code>	Input parameters of a block. Available only when the edited group is a UDFB.
<code>VAR_OUTPUT</code>	Output parameters of a block. Available only when the edited group is a UDFB.

3.1.5.1.16.1 Basic Syntax for Declaring a Variable

To declare a variable, enter its symbol followed by a colon (:) and its data type.

3.1.6 Data Type: STRING

If the data type is `STRING`, it must be followed with the maximum length in parentheses (e.g., `STRING (255)`).

```
MyVar : BOOL;
MyString : STRING(255);
```

3.1.7 Read-only Attribute

To indicate that a variable has the **read-only** attribute, insert the `CONSTANT` keyword at the beginning of the variable declaration:

```
CONSTANT VarName : DataType;
```

3.1.8 Declare an Array

To declare an array, the data type must be preceded by `ARRAY [dimensions] OF`.

- There are at most three dimensions, separated by commas.
- Each dimension is specified as **0 .. MaxBound** (e.g., `0 .. 9`).

```
Array1 : ARRAY [0 .. 99] OF DINT;
Matrix : ARRAY [0 .. 9, 0 .. 9, 0 .. 9] OF REAL;
```

3.1.9 Single Variable Input Value

You can specify an initial value for single variables.

- The initial value is entered after the data type and is preceded by `:=`.
- The initial value must be a valid constant expression that fits the data type.

```
MyBool : BOOL := TRUE;
MyString : STRING(80) := 'Hello';
MyLongReal : LREAL := lreal#1.0E300;
```

3.1.9.0.1.1 Additional Information and Description Texts

Variables may have additional properties and comment texts in the KAS-IDE.

Special directives are entered as IEC comments AFTER the declaration of the variable, to specify additional info.

These directives are available:

Directive	Description
(* \$desc=Text *)	Variable description
(* \$embed=Text *)	Variable embedded properties (the syntax is the one shown in the variable grid, in the "Property" column)
(* \$profile=ProfileName *)	Variable embedded profile
(* \$tag=Text *)	Variable tag (short comment)

Optional: Use // single line comments to enter the directives:

```
// $tag=Text
// $desc=Text
// $profile=ProfileName
// $embed=Text
```

3.1.9.1 Enum tab

This tab allows you to define enums (Enumerated Types). An enumerated type allows you to define a data type and assign a specific set of accepted values.

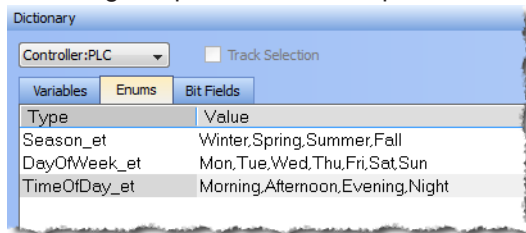

3.1.9.1.1 Adding Enums

An enum may be created in one of two ways:

- Right-click within the Enum tab and select **Insert Enum**.
- Press the **Insert** key while the Enum tab is active.

This creates a default enum labelled as "EnumType_n" with the Value of "V0, V1".

Double click on the Type or Value to make changes.

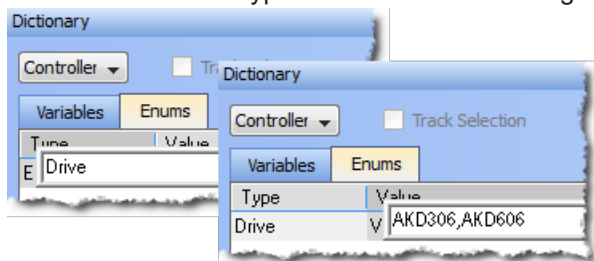

NOTE

- An enum must contain two or more values. If only one value is defined, it will not be considered and the previous value will be retained.
- An enum should not contain special characters such as #, @, etc.. If a special character is defined in the value field, it will not be considered and the previous value will be retained.

3.1.9.1.2 Create Enums

1. Enter the enum type and hash (#), the press Ctrl+Space. This opens a dialog to select the corresponding value.

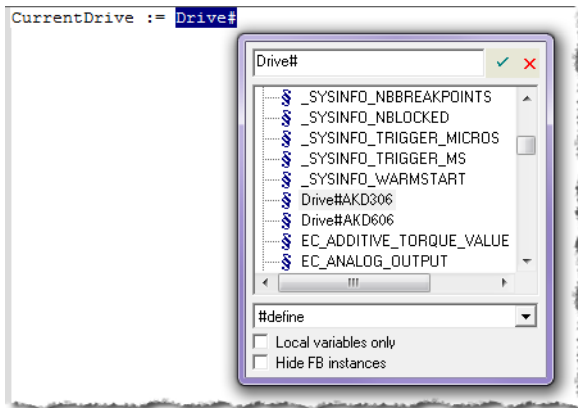

2. Select the value and click the check mark. The value is loaded into your program.

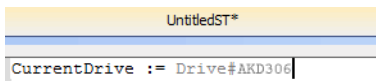

3.1.9.1.3 Declaring Enums

Enums may be declared in the same way as variables; at the end of the line press Enter.

As CurrentDrive is not a part of the dictionary, a dialog is opened to add the variable. Set the Types as the enum name.

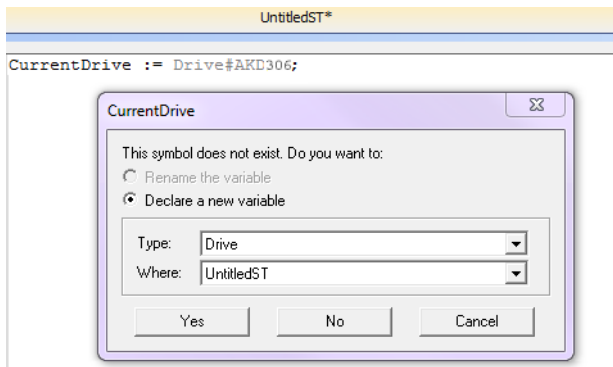

Once this is added, the variable will be displayed with the selected type in the Dictionary.

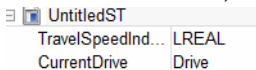

3.1.9.2 Bit Fields tab

A bit field packs multiple pieces of data together in one variable. Each field represents one piece of data. Each piece of data should have no dependency upon other fields. Bit Fields are used to define custom variable types and values.

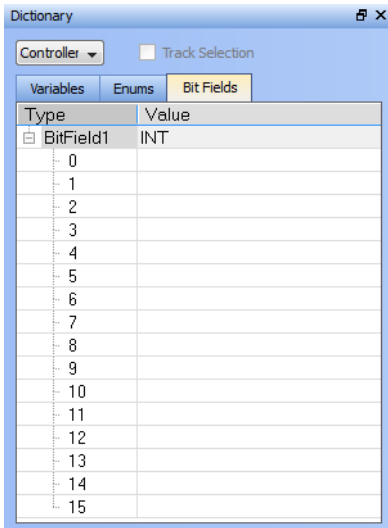

3.1.9.2.1 Adding Bit Fields

A Bit Field may be created in one of three ways:

- Right-click within the Bit Fields tab and select **Insert BitFields**.
- Press the **Insert** key while the Bit Fields tab is active
- Double-click within the Bit Fields tab.

This creates a default Bit Field labelled as "BitFieldn" with a Value type "INT".

- The Bit Field type **Value** may be modified by double-clicking on value, allowing a selection from a list.

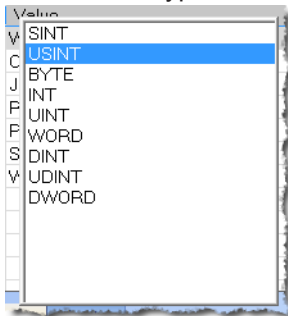

Once the Type is defined you may populate the bits.

- Double click on a bit value to change the text.

ⓘ IMPORTANT

To save your changes you must press **Enter**, **Tab**, the Up, or the Down arrow key.

NOTE

Bit Fields are supported over MODBUS. Below is a variable with a custom Type defined in the Bit Fields list which is flagged for KVB. It will be exported to MODBUS.

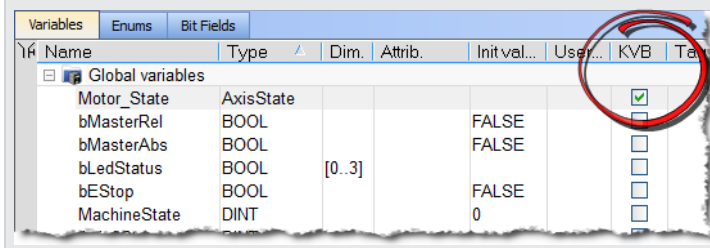

3.1.9.2.2 Using Bit Fields

Following is an example of setting up and testing a Bit Fields entry.

1. Define the Bit Field Type and Values.

Here we have defined a bit called **AxisState** with four values.

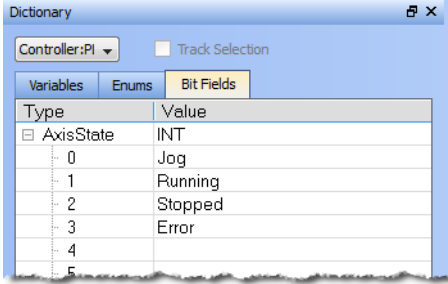

2. Create a variable whose Type that matches the Bit Field.

Here we have defined a variable called **Motor_State**. We selected the **AxisState** type from the dropdown menu.

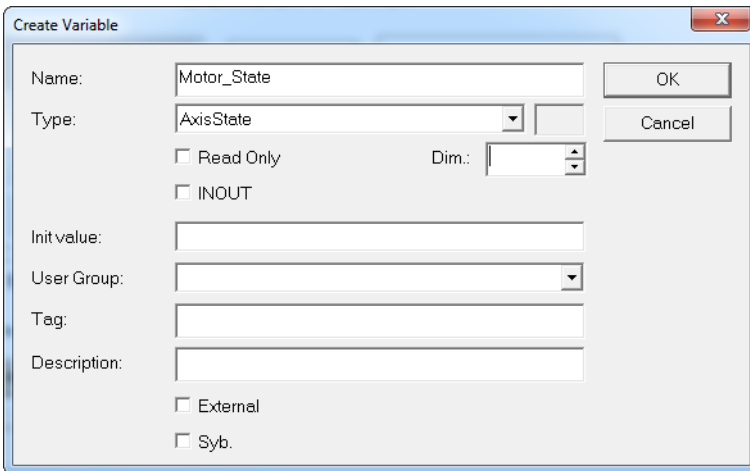

3. To use the bit enter `VariableName.BitName` in any editor.

Here we are using the Structured Text editor and typed "motor_state." When the dot was typed the selector opened, showing us the available bits for the variable.

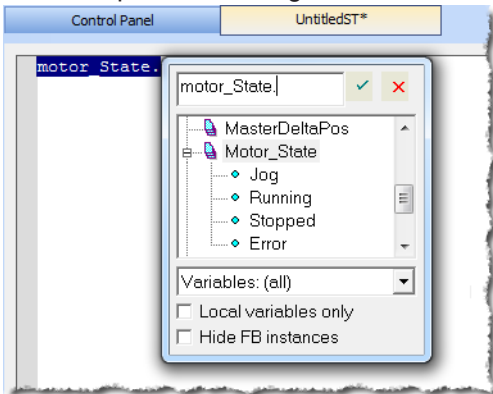

3.1.10 Information and Logs window

The Information and Log window is used to identify current state status and can be used to identify operational errors, compilation errors, and also to quickly assist you in finding areas of the workspace or program variables.

This window contains these tabs:

- "Breakpoints tab" (→ p. 114) with a list of breakpoints.
- "Browse Variable tab" (→ p. 112)
- "Compiler Output tab" (→ p. 115) with state reports.
- "Find and Replace tab" (→ p. 108) for a system search.
- "Log Messages tabs" (→ p. 103) (Local or Controller) including "Log Messages Settings" (→ p. 104).

3.1.10.1 Log Messages tabs

TIP

Log messages are an important source of information when troubleshooting with KAS-IDE. When reporting an issue to Kollmorgen Support, copy/paste the logs in your report.

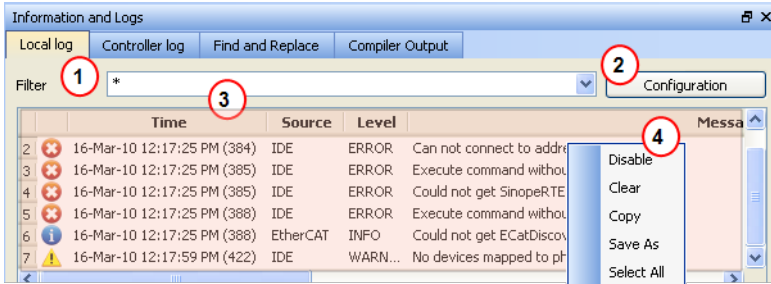

Figure 3-5: Log Messages - Local Log

Log messages are displayed on two tabs, **Local log** and **Controller log**.

- The **Local Log** tab shows all messages managed by the KAS-IDE to explain the current state of the system and to help identify any operation errors encountered when developing your system.
- The **Controller Log** shows all messages managed by the KAS Runtime.

Based on the configuration settings (see call out (2)), only messages that are recorded and that match the filter (1) are displayed.

TIP

The Configuration button is only available on the Controller log tab when the IDE is connected to a controller.

Every log message in the table widget (3) has the following information:

Field	Description
Time	Time when the log was recorded with the format: DD-MMMM-YY hh:mm:ss (millisecond)
Source	Identifies a software or hardware component issuing the messages. Each source is <u>configured</u> with a specific Level.
Level	Each message has one of the following levels with importance in ascending order: DEBUG > INFO > WARNING > ERROR > CRITICAL
Message	Text of the message issued from the source

Table 3-1: Log Messages - List of Fields

The table contains a contextual menu (see call out (4)) with the following commands:

Command	Description
Disable/Enable	You can stop the log recording at any time, so that no more messages are added
Clear	Empty the list by erasing all the messages already recorded
Copy	Copy the text of the selected messages to the clipboard (you can perform multi-selection with the Ctrl or Shift keys)
Save As	Save all the messages in a log file
Select All	Select all the messages that are displayed in the table

Table 3-2: Log Messages - List of Buttons

3.1.10.2 Log Messages Settings

The KAS-IDE manages all messages according to these gates:

- "Configuration Settings" (→ p. 104) define what is recorded in the database.
- "Filtering" (→ p. 107) defines which messages are displayed in the table widget.

3.1.10.2.1 Configuration Settings

Figure 3-6: Configuration of the Local and Controller Log Messages





Call Out#	Description
1	<p>Each log source can be set with its own notification level.</p> <ul style="list-style-type: none"> • It is possible to get a maximum of log details for the selected source without getting a flood of irrelevant messages from the other sources by controlling the level of each source. • See: <ul style="list-style-type: none"> • "Message Sources" (→ p. 104) • "Log Message Levels" (→ p. 105) • "Choose the Appropriate Level for a Log" (→ p. 106)
2	You can set or reset all the sliders with the same level value
3	<p>Logs can be recorded on the local machine as circular files.</p> <ul style="list-style-type: none"> • On the controller, the recording of the logs is enabled by default. <ul style="list-style-type: none"> • See "Local Log File Settings" (→ p. 105).

Message Sources

Source	Apply to...
Controller	<p>For the KAS Runtime items:</p> <ul style="list-style-type: none"> • Drivers • IOEngine • SinopEngine
Drive	Messages from AKD drive

Source	Apply to...
EtherCAT	For all kinds of EtherCAT items: <ul style="list-style-type: none"> • Motion bus • I/Os
IDE	Win32 Applications: <ul style="list-style-type: none"> • KAS-IDE • KAS Runtime Server (aka KAS Runtime Front-end)
Motion	Messages coming from the Motion engines: <ul style="list-style-type: none"> • PLCopen • Pipe Network • VM
PLC	For application engineers to create custom log in the PLC programs. See "Print" (→ p. 235).
System	For common API and libraries. Includes messages issued from the operating system.

Log Message Levels

Level	Icon	Description
CRITICAL		Application crashes or becomes unstable. <ul style="list-style-type: none"> • Data is corrupted. • At that point, the application behavior can be unpredictable.
ERROR		The application does not behave as expected but the processes remain stable.
WARNING		System is stable but the KAS-IDE warns that an unexpected event can occur. <ul style="list-style-type: none"> • This is the default logging level. • You can ignore this log.
INFO		Information status of the current process. You can ignore this log.
DEBUG		Any information logged for development purpose. You can ignore this log.

Each message has one of these levels, with importance in ascending order:
DEBUG > INFO > WARNING > ERROR > CRITICAL

Local Log File Settings

Log files are a group of small files where all the last logs are recorded. Each log is recorded as a separated line.

TIP

You can import the log files into Microsoft Excel using drag-and-drop.

Field	Description
Enabled	The Log File Settings has to be enabled to record all the logs.

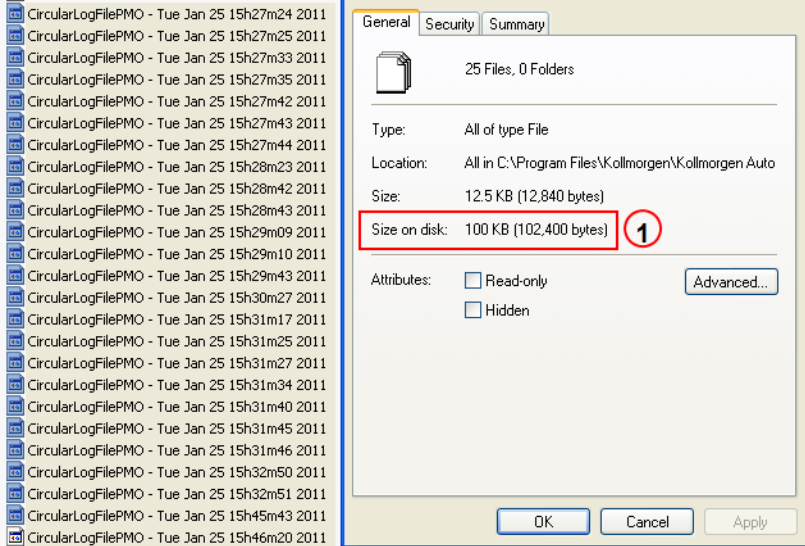
Field	Description
Log size	<p>To prevent any overflow, you can define the maximum size on disk dedicated to the group of local log files.</p> <ul style="list-style-type: none"> • The minimum size is 1MB, the maximum log size is 2MB. • At most, the system stores 20 files. • When a new file is created, an old one is deleted, maintaining the 20 file threshold. • In Figure 3-7, the size on disk is limited to 100 KBytes (see 1). 
Log Directory	<p>The Log Files are stored in this directory.</p> <ul style="list-style-type: none"> • Each KAS-IDE instance has a unique log directory, defined by the process identification number. • You can access the local log files for this specific instance of the KAS-IDE, by clicking this link to open the directory location in the File Explorer. • See "Log File Storage" (→ p. 107).
Log name	<p>You can define the file name prefix to be used on the local machine (on the controller, the file name prefix is: controller logs).</p> <p>The suffix to create the complete filename contains a timestamp with the following format: - day MMM DD HHhMMmSS YYYY nn.</p> <div style="background-color: #333; color: white; padding: 2px; text-align: center;">NOTE</div> <p>The Log name change is applied immediately. The name used by the next IDE instance is determined by the last IDE instance.</p>

Choose the Appropriate Level for a Log

When a level is set for a source, only messages with the same or higher importance are recorded.

- Drag the level control slider **Up to reduce** the verbosity, **Down to increase** it.
- When the configuration leads to lower verbosity, the treatment during the filtering is quicker.
 - Example: If a source is set to WARNING, then all messages with levels WARNING, ERROR and CRITICAL are recorded (DEBUG and INFO messages are discarded).
DEBUG is the most verbose, whereas ERROR is the less verbose.

NOTE
Critical messages are always recorded; as a consequence, the Critical level is not visible on the slider.

Log File Storage

- For the local machine (IDE), the Log files are located in the following location:
C:\Users*(user name)*\AppData\Local\Kollmorgen\KAS\Astrolabe\logs\IDE*(process ID)*
- For the controller, the Log files are located under:
C:\Users*(user name)*\AppData\Local\Kollmorgen\KAS\Sinope Simulator\Application\logs
- The AKD PDMM or PCMM logs are accessed via the web server page by browsing to:
KAS Application > Log Data.

TIP
AKD PDMM/PCMM generated logs may be configured through the webpage. See "Controller Log Files" (→ p. 412).

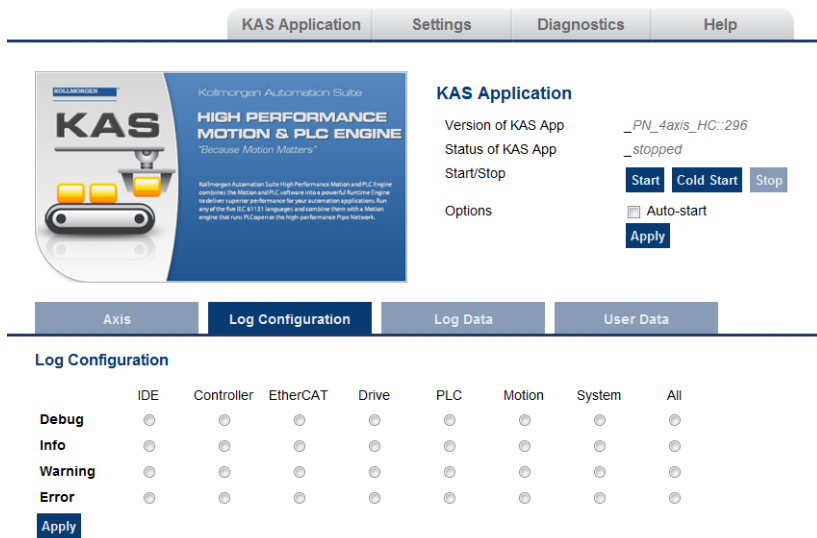

Figure 3-8: Log Configuration tab

NOTE
It is recommended that you use either the KAS-IDE or webpage method, but not both. The communication is unidirectional and the configuration is not read at runtime.

3.1.10.2.2 Filtering

You can narrow the list of recorded messages by specifying a filter.

The filter is applied on all the strings displayed on each row of the table widget (i.e., Time, Source, Level and Message).

The drop-down menu gives access to some predefined filters, which can also be edited.

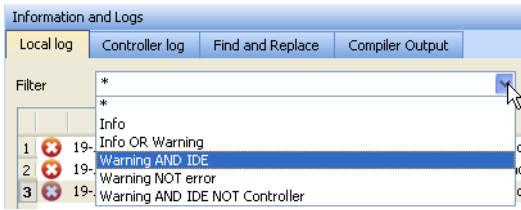

Figure 3-9: Filtering the Messages

Example: Filtering with **Warning NOT error** means that only the lines including the word "warning" but not the word "error" are listed.

3.1.10.2.3.1 Filtering Rules

These are the filter rules:

- You can combine several strings by including one of these Boolean operands:
 - OR
 - AND
 - NOT (or use the exclamation mark "!")
- Several keywords separated with spaces are considered as an exact string.
- Filtering is **not** case sensitive.

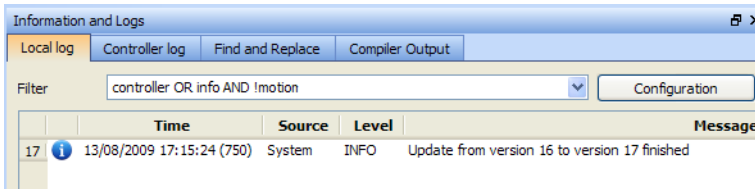

Figure 3-10: Example: Filtering the Messages

⚠ WARNING

When you apply the filter, all the currently recorded messages are parsed and displayed if they match the filter. But all the upcoming recorded messages are added as new rows at the end of the table widget with **no filtering**.

3.1.10.2.4.2 Log Scrolling

If you select a message in the table, the scrolling is **stopped**.

All the upcoming recorded messages are added at the end of the list, but the selected message always remains in the same place (you have to scroll down to make the most recent messages visible).

If you select the last row of the table (shortcut: **Alt+Page Down**), the scrolling is **active**.

The last recorded message is always selected and visible at the bottom of the table.

3.1.10.3 Find and Replace tab

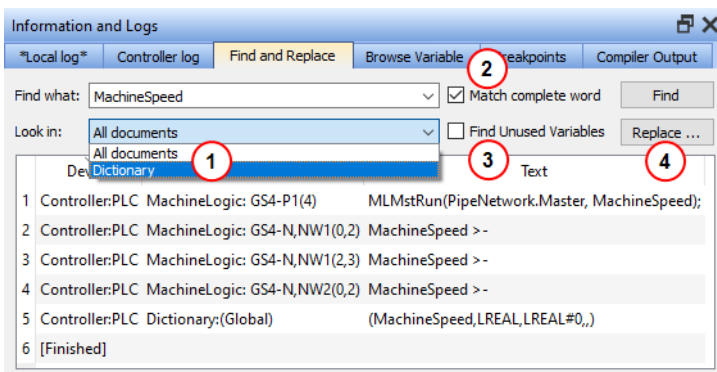

Figure 3-11: Find and Replace tab

This tab is used to search for all the instances of a string of characters (search is **not** case sensitive) in the entire environment and replace it.

You can re-use one of the last ten entries or type a new text string.

Call Out#	Description
1	<p>The operation can be performed across:</p> <ul style="list-style-type: none"> All documents: Search all files of the project and the dictionary. Dictionary: Search the dictionary.
2	<p>The search string can be with a complete word only.</p> <ul style="list-style-type: none"> When this option is selected, the search is case sensitive. When selected, only the instances that match the complete words defined in the Find what field are selected. <ul style="list-style-type: none"> Example: A search for "MyVar" returns "MyVar" but not "MyVariable".
3	<p>To optimize a project, the Find Unused Variables option is used to perform a search in the dictionary to locate variables not used in any program.</p> <ul style="list-style-type: none"> A variable is not used when there is no effective usage of it in your entire project. <ul style="list-style-type: none"> It can still be the case even when a value is assigned to a variable (e.g., <code>MyVar := 100. * Axis1.Velocity;</code>). The variable <code>MyVar</code> becomes used when it is affected as an input argument (e.g., <code>Velocity := MyVar ;</code>). Select this option and click Find to generate a list of the unused variables. You can select one or more variables (by Shift- or Ctrl-clicking) and right-click to open the context menu. The menu includes a Delete option (Figure 3-12). Double-click a variable in the list within the table widget to open it in the Dictionary.

The screenshot shows the 'Find and Replace' tab in the 'Information and Logs' window. The 'Find what:' field is empty, and 'Look in:' is set to 'All documents'. The 'Match complete word' checkbox is unchecked, and the 'Find Unused Variables' checkbox is checked. The 'Find' button is visible. Below the search options is a table with the following data:

	Device	Location	Text
67	Controller:PLC	Dictionary:Main	(VelCheckCounter,DINT,...)
68	Controller:PLC	Dictionary:Main	(BuildCounter,DINT,...)
69	Controller:PLC	Dictionary:Main	(Inst_MLProfileRelease1,MLProfileRelease,...)
70	Controller:PLC	Dictionary:Main	(Inst_MC_CamOut,MC_CamOut,...)
71	Controller:PLC	Dictionary:Main	(EndRange,DINT,...)
72	Controller:PLC	Dictionary:Main	(Inst_TON,TON,...)
73	Controller:PLC	Dictionary:Main	(Inst_MLAxisStop,MLAxisSto...
74	[Finished]		

A context menu is open over row 71, showing options: Clear, Copy, Select All, and Delete (highlighted).

Figure 3-12: Find and Replace tab with Delete menu option Selected

Call Out#	Description
4	<p>Use the Replace... button to replace in all documents a string with another one (or re-use one of the last ten entries).</p> <ul style="list-style-type: none"> The search can be refined by forcing the search to a Whole word, and may be case sensitive or Case Insensitive (Figure 3-13). The replace function is limited. <ul style="list-style-type: none"> It is not supported in the Dictionary, Pipe Network, and HMI. <ul style="list-style-type: none"> For these, the change must be made manually.

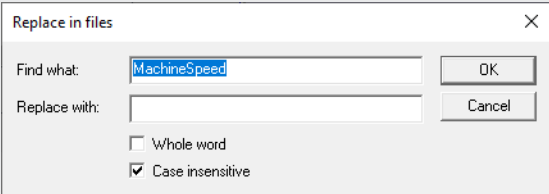

Figure 3-13: Replace in Files dialog box

Once the search is done, the results appear in the table widget at the bottom of this tab.

If a replace has been performed, the Text column provides more information about the replacement.

Double-click the applicable item in the list to open it in its relevant location (it can be a PLC editor or the Dictionary).

3.1.10.3.1 Location Details

Understand the Location Details — SFC Programs

SFC Location details

```
2 controller:PLC MachineLogic: GS101-P1(4) MLMstRun(PipeNetwork.Master, TravelSpeed);
```

- Controller : PLC and MachineLogic refer to the program in the Project Explorer
- GS stands for Graphical and Step (T is for Transition)
- 101 is the reference in the editor

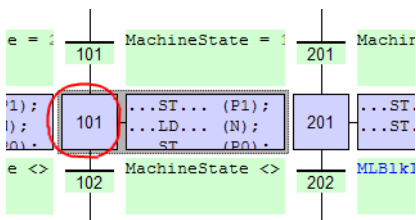

- -P1(4) refers to the P1 tab and the 4th line in the source code:

First Level Actions **P1** N PO Notes

ST/IL FBD LD FFLD

```
Printf('Manual mode', 0, 0, 0, 0);
// Start motion
MLMstRun(PipeNetwork.Master, TravelSpeed);
```

How to Understand the Location Details — FFLD Programs

FFLD Location details

```

Controller:PLC:>> Complex variables stored in a separate segment
Controller:PLC>Loading application symbols...
Controller:PLC:Main
Controller:PLC:Main: G55-N,NW15(4,2): Object not connected on the left
Controller:PLC:Main: G55-N,NW15(4,0): Bad value on box input(s)
Controller:PLC:Error(s) detected
Controller:----- PLC Failed -----
    
```

- **Controller:** PLC and Main refer to the program in the Project Explorer.
 - GS stands for Graphical and Step (T is for Transition)
 - 5 is the reference in the editor.
 - -N refers to the N tab.
 - NW15 stands for Network number **15**.
 - (4,2) correspond to the **X,Y** coordinates of the cell relative to the current network:

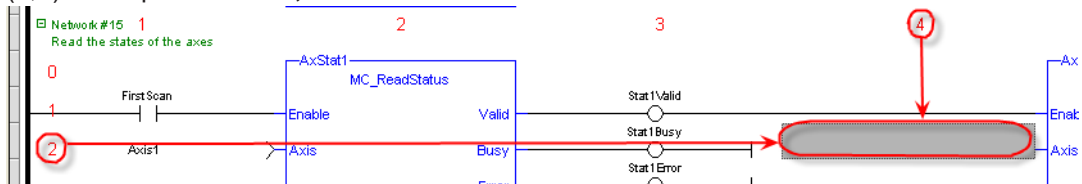

Understand the Location Details — ST Programs

ST Location details

```

Controller:PLC:MyST_function
Controller:PLC:MyST_function: (5): Array index expected - must be a DINT expression
Controller:PLC:Error(s) detected
    
```

- **Controller:** PLC and MyST_function refer to the program in the Project Explorer.
 - (5) refers to the 5th line in the source code.

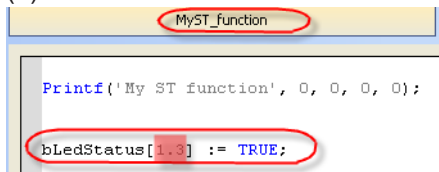

See "Find and Replace Operations" (→ p. 111).

3.1.10.4 Find and Replace Operations

The Find and Replace command enables you to search for a specified string of characters within your project.

You can use any of the following methods to access this functionality:

- From the **Information and Logs** toolbox
- In the **Dictionary** panel
- From an **editor** (FBD, FFLD, IL, ST)

3.1.10.4.1 Information and Logs

See "Information and Logs window" (→ p. 102) for more information.

3.1.10.4.2 Dictionary

Right-click on the variable name and select the **Find all** command in the menu.

This command starts a search of all documents for the selected variable and displays the results in the table widget within the "Information and Logs window" (→ p. 102) toolbox.

NOTE

This operation selects only the instances that match the complete words (for example, a search for "MyVar" returns "MyVar" but not "MyVar1").

3.1.10.4.3 Editor

It is possible to perform a search and replace from a PLC editor (FBD, FFLD, IL, ST) by selecting the **Find**, **Find next**, and **Find All** commands in the contextual menu.

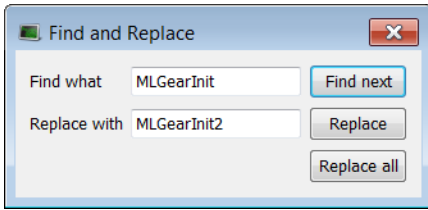

Figure 3-14: Find and Replace from an Editor

Function	Description
Match Whole Word	When selected, only the instances that match the complete words defined in the Find what field are selected. Example: A search for <code>MyVar</code> returns MyVar but not MyVar1 .
Find next	Used to select in the current editor the next instance of the matched string.
Replace next	Used to replace the next instance of the matched string.
Replace all	Used to replace in the current editor all instances of the matched string.

NOTE

The **Find**, **Replace** and **Replace all** operations work only for **variable symbol** property of the **Control**.

TIP

When the Find All command is applied to a variable, the system returns a list of all instances of the variable, not just those in the current program.

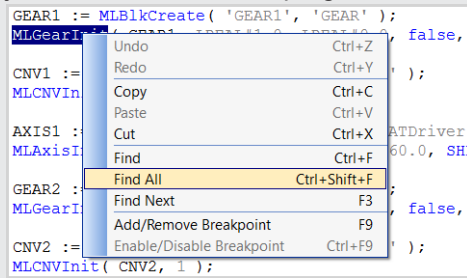

3.1.10.5 Browse Variable tab

This tab is used to browse all instances of a variable. It will show the locations and usage of each instance of a single variable. There are two ways to populate the tab:

- Click the **Select Variable** button.
See "Using the Browse Variable tab" (→ p. 113).

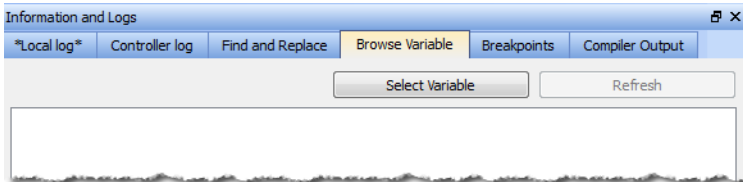

- Right-click on a variable in the Dictionary and select **Browse Variable**. See "Using the Dictionary's Browse Variable menu item" (→ p. 113).

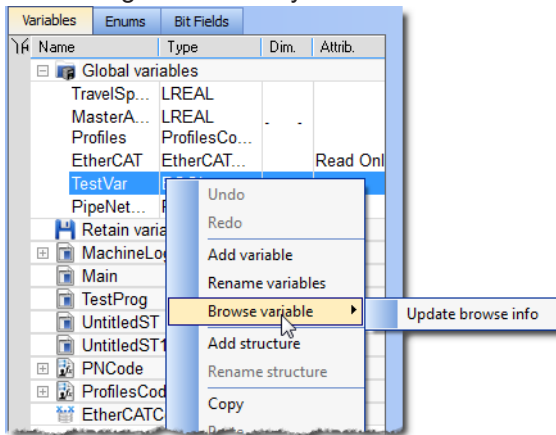

3.1.10.5.1 Using the Browse Variable tab

1. Click the **Select Variable** button to open a variable selection pop-up window.
2. Select a variable from the pop-up list.

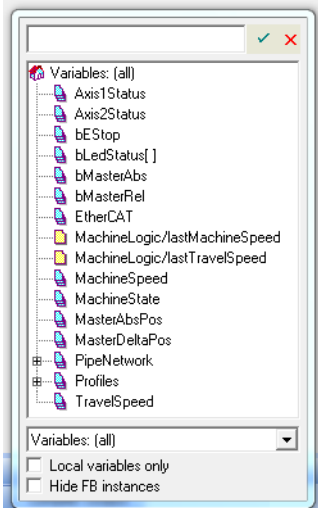

3. The Browse Variable tab is updated with a two-column table detailing the variable's usage
 - **Location** shows the file name and line number where the variable is used.
 - **Usage** shows whether the variable is being read (**use**) or written to (**set**).
4. Double-click on an entry to be taken to the corresponding location in the editor.

NOTE

- The process of generating the Browse Variable content after clicking Select Variable can take a significant amount of time, depending upon the number of files in the project. If there are no modifications to the project, further browse operations will not take any time.
- The browse information may not be current if changes are made to the project.
- The browser information needs to be refreshed after saving and compiling a project. A message is shown in the tab to alert you if the information may not be accurate.

3.1.10.5.2 Using the Dictionary's Browse Variable menu item

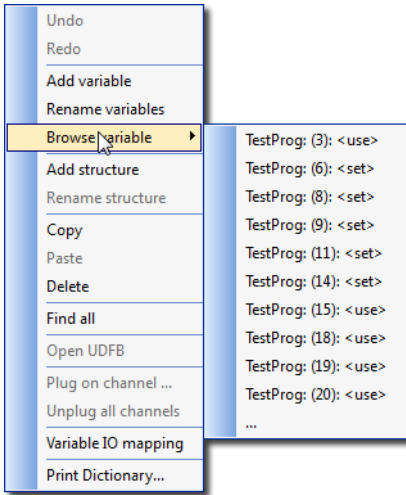

The first time this menu is accessed (per project instance) you are presented with **Update browse info**.

- This updates the browse data.
- Further selections of any variable result in the location and usage being shown directly in the menu.
- Selecting an entry will take you to the corresponding location in the editor.

When the menu has more than ten entries an ellipsis (...) is added to the bottom of the menu.

- Selecting the ellipsis (...) opens the Browse Variable tab.
- This tab is populated with the variable locations and usages.

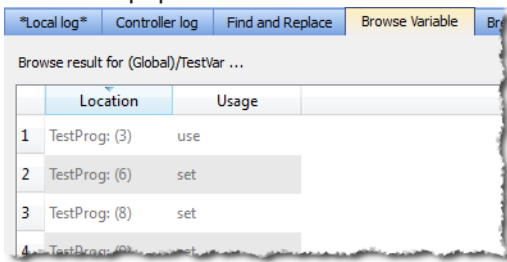

3.1.10.6 Breakpoints tab

The Breakpoints tab lists all of the breakpoints in the PLC program, including their position and status.

- Double-click an entry to move to that location in the editor.
- Breakpoints may be enabled and disabled singly by clicking the **Status** check boxes.
- Buttons on the left of the tab provide the ability to remove single breakpoints, enable and disable all breakpoints, and remove all breakpoints.

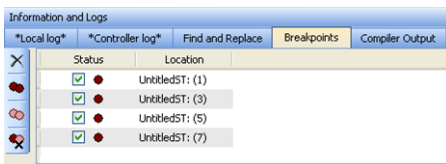





Figure 3-15: Breakpoints tab

Button	Action Performed
	Delete selected breakpoint from the list and editor.

Button	Action Performed
	Enable all breakpoints. This makes all breakpoints active.
	Disable all breakpoints. This makes all breakpoints inactive.
	Remove all breakpoints.

Right-clicking a breakpoint entry in the list provides for enabling, disabling, deleting the entry, and going to that location in the source code.

Breakpoints (both active and inactive) which have been reached in the code are flagged with a yellow triangle.

This provides a quick and easy way to identify the breakpoint.

This can be seen in both the code and the Breakpoints tab.

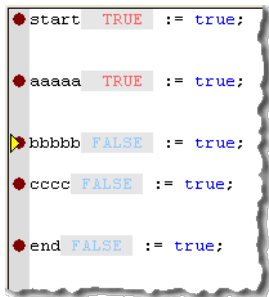

Figure 3-16: Breakpoints code

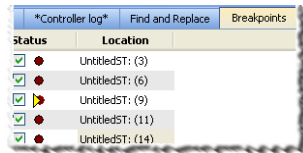

Figure 3-17: Breakpoints tab

TIP

Any program (except for an SFC program) that contains a breakpoint that gets "hit" during debugging will be automatically opened for your convenience.

As breakpoints set in SFC programs cannot be enabled or disabled, entries in the Breakpoints widget do not have a checkbox to perform these actions.

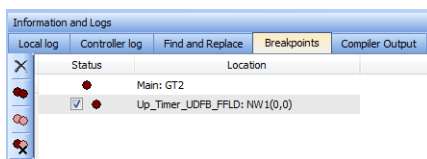

Figure 3-18: Example of a breakpoint (Main: GT2) set in an SFC program.

See Also

- "Breakpoints" (→ p. 232)
- "Setting, Removing, Enabling, and Disabling Breakpoints" (→ p. 234)

3.1.10.7 Compiler Output tab

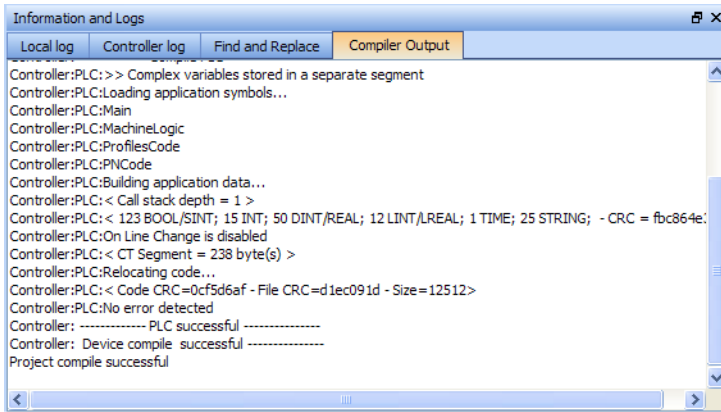

Figure 3-19: Compiler Output tab

This tab shows:

- Information about the last project compilation.
- Information messages as well as Warnings and Errors (highlighted in red).
- Successful and unsuccessful output is reported to help identify and troubleshoot problem areas of the program development.

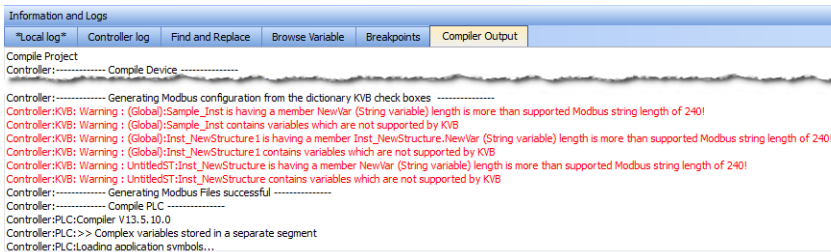

Figure 3-20: Compiler Output tab with Warnings

TIP

Double-click an error to open the program in the workspace and jump directly to the relevant location in the editor.

This lets you rework the program and fix the error.

In Figure 3-20, the first warning is for Sample_Inst.

Double click the item opens that item's location in the Dictionary.

Name	Type	Dim.	Attrib.	Init value	User ...	KVB
Global variables						
TravelSpeed	LREAL			LREAL...		<input type="checkbox"/>
MasterAbsPos	LREAL			LREAL...		<input type="checkbox"/>
MasterDeltaPos	LREAL			LREAL...		<input type="checkbox"/>
PipeNetwork	PNCode					<input type="checkbox"/>
Sample_Inst	NewStructure					<input checked="" type="checkbox"/>
Inst_NewStructure1	NewStructure					<input checked="" type="checkbox"/>

Figure 3-21: Item open in Dictionary

When there is a long list of statements, only the bottom part is displayed. Do not forget to scroll up.

How to Clean-up the Code

1. Scroll up to start from top and locate the first error message.
2. Fix the error.

TIP

Because fixing **one** piece of code can eliminate **multiple** compiler output error, it is recommended to recompile each time you correct an error.

When no more errors exist, these messages are shown:

- PLC successful (the IEC 61131-3 code is correct).
- Device compile successful (is related to the Motion part (e.g. CAM profiles), EtherCAT XML file...).
- Generating Modbus files (related to the variables mapped with the HMI).
- Project compile successful (the complete project is ready to be downloaded to the target).

Text Displayed

Operands of * or / must be numbers and have the same type

Meaning

- This error appears in a ST instruction when a constant expression does not have the expected type in a multiplication or division operation.
- Typically, REAL is the default precision for floating points, so you must explicitly declare the long real constants with the LREAL# prefix when required.
- See "Constant Expressions" (→ p. 710).

3.1.11 Watch Window

This toolbox is used to add variables to a dedicated Watch Window to view its value in real time.

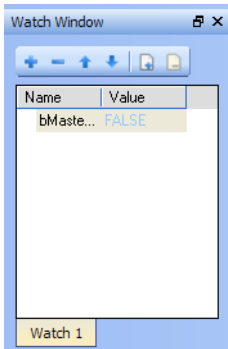

Figure 3-22: Watch Window

NOTE

- PLC variables viewed in the Watch Window are saved as a part of the project.
 - This means that the next time you open the project, those variables are pre-loaded in the Watch Window.
 - This does not apply to AKD variables, which are not saved with the project.
- While variables may be changed, locked, or unlocked, parameters are not.
 - See "Force a Variable" (→ p. 120) for more information.
 - AKD parameters in the Watch Window are read only.



3.1.11.1 Multiple Watch Windows





The KAS-IDE allows you to group several variables in a single Watch Window.

- A maximum of 10 different Watch Windows is allowed.
- Each window is shown as a tab with its own label.

Explanation for each icon:

Watch Window - List of Icons

Icon	Description
	Add a variable with the PLC Variable Selector .
	Remove a variable.

Icon	Description
	Move up the selected variable.
	Move down the selected variable.
	Add a new Watch Window. Each window is shown as a tab with its own label. A maximum of 10 tabs is allowed.
	Remove the selected watch window.

TIP

You can also add an existing variable in the watch window directly by using **drag-and-drop** from the Dictionary or the PLC editors.

Each variable in the table widget has this information:

Field	Description
Name	Lists the variables as well as structure , arrays , and expressions. Double-click a variable (or press the F2 key when the variable is selected) to edit its name (except for structure and array members).
Value	When the application is running, this is the variable or expression's value. Double-click a value to force modification of the selected variable.

The contextual menu allows you to:

- Add a variable.
- Remove a variable.
- Remove all variables.

3.1.11.2 Access Structure and Arrays

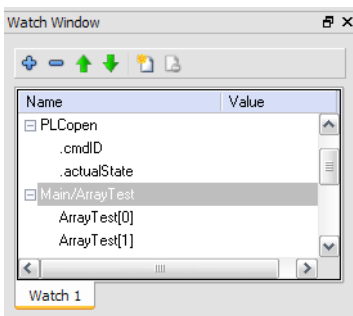

Figure 3-23: Watch Window - Accessing Arrays

When a structure or an array is in the watch window, you can expand its node to display all its members. Note that structure or array members cannot be deleted, edited or moved up/down in the list.

3.1.11.3 Add Variable

1. Double-click the nodes ((**Global**), **Main**, etc.) to expand their related variables.

TIP

Expand AKD node to add AKD parameters to the Watch Window.

2. Select one from the list.
3. Click **OK**.

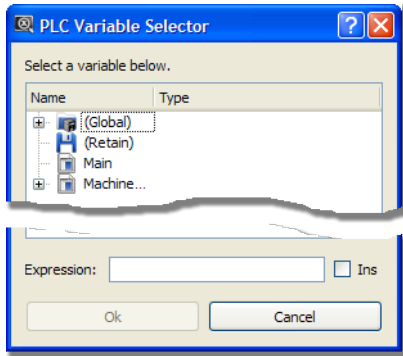

Figure 3-24: Watch Window - Selecting PLC Variable

This variable is added to the current Watch Window tab.

3.1.11.4 Add an Expression

You can enter variable strings as an expression.

Example: Use this procedure to add together two integer variables:

- Click the Add symbol **+** to open the PLC Variable Selector.
- Choose a variable, but do not click OK yet.
(the variable is added to the expression field where you can do any required editing)
- Select the **Ins** option.
(this option allows you to insert the next selected variable at the current cursor position in the expression edit field)

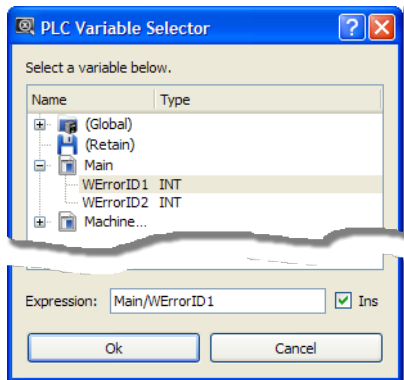
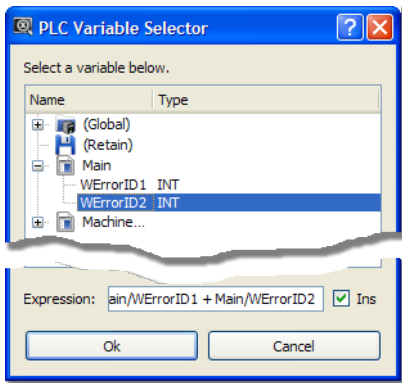

Figure 3-25: Watch Window - Creating Expression

- Press the PLUS SIGN (+) in the expression field.
- Select another variable.

- Click the **OK** button.



- Then the expression is displayed into the watch window

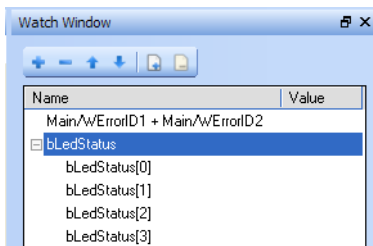

Figure 3-26: Watch Window - Displaying Expression

What you can include in a complex expression:

- Index of array
- Comparison “>”, “<”, “<>”, “=”
- Operator “+”, “*”, “-”, “/”

NOTE

The DIVIDE SIGN (/) is not interpreted as an operator when used with prefixed variables (e.g., MachineLogic/lastTravelSpeed)

3.1.11.5 Force a Variable

At run-time, all variables in the table widget are animated ¹ with real-time values.

You can double-click on the value of a variable (or press the **ENTER** key when it is selected) to open a pop-up window that allows you to:

- **Force:**
change the value of the selected variable. Depending on the variable type, you have the possibility to define its value either in the text field or with the check boxes.

¹To better track variables and expressions of the PLC programs in test mode, the KAS-IDE dynamically computes their value along with the execution and displays the result

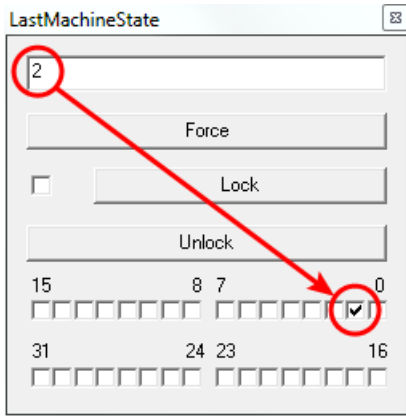

Figure 3-27: Forcing a variable

- Lock:**
 Variables, member variables of a structure and variables in an array may be locked. When a variable is locked, its value is no longer changed by the runtime. You can then force its value from the debugger independently from the runtime operations.

NOTE

The value of a locked variable is displayed with square brackets.

```
ActualMachineState [[ -1 ]] := -1;
```

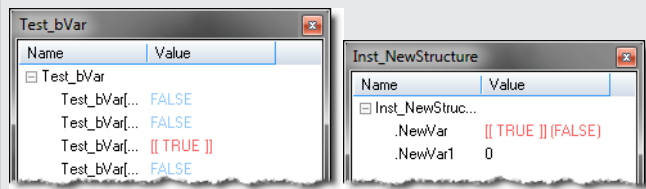

The variable locking feature can be enabled or disabled via the PLC Options device toolbar button. If enabled, the Lock and Unlock buttons are accessible:

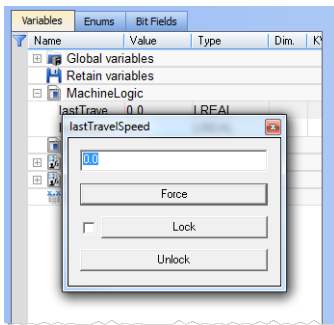

If disabled (default), the Lock and Unlock buttons are not accessible:

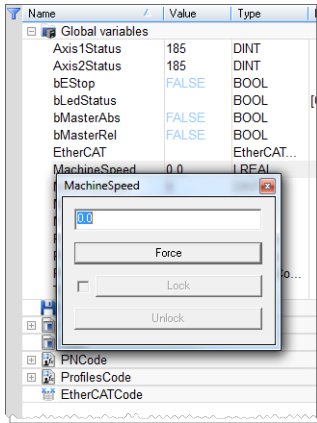

ⓘ IMPORTANT

If PLC variable locking is enabled, the controller Runtime requires an additional 3% to 10% CPU processing power to manage the PLC variable locking. For the best controller performance, disable PLC variable locking.

- **Unlock:**
Remove the lock on a variable so that it can be changed again by the runtime.

3.1.12 AKD Drive

First generation AKD drives support one axis per drive, while AKD2G drives support two axes per drive. When configuring drives in the "EtherCAT Devices tab" (→ p. 322), you need to designate which motion axis applies to each drive axis, which is the actual axis the drive controls.

In addition to different views, WorkBench provides a "WorkBench Toolbar" (→ p. 122) and "WorkBench Status Bar" (→ p. 122) to display some extra information.

3.1.12.1 WorkBench Toolbar

The toolbar provides access to these actions:

- Enable / Disable the drive (software enable).
- Start / Stop the Service Motion.
- Mode: Position / torque / velocity
- Disable and Clear Faults: Click this button to clear the fault, then click the Enable button to enable the drive again.

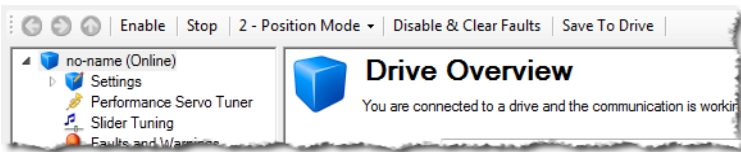



Figure 3-28: AKD Toolbar

👉 TIP

To stop all the AKD drives at the same time, click the Stop button  in the "Device Toolbar" (→ p. 250).

3.1.12.2 WorkBench Status Bar

The status bar provides the following information on the drive:

- A fault indicator (No Faults / x Faults) that becomes red when any AKD gets a fault.
 - Use the "Log Messages Settings" (→ p. 104) to get more details on the drive messages.
- The drive status: active / inactive.

- The software (SW) enable status.
- The hardware (HW) enable status.

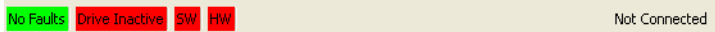

Figure 3-29: AKD Status Bar

For the SW and HW enable status indicators, the color code is:

- **Green** when it is OK (i.e., everything is ready to do motion).
- **Red** in case of errors / faults.
- **Grey** for all other cases (e.g., when SW or HW is not enabled, the status is not green because a motion could not happen, and not red because it is not an error).

3.1.13 Status Bar

A status bar located at the bottom of the KAS-IDE main window displays the five following labels from left to right:

- [Local version](#)
- [Controller version](#) (application version located in the controller)
- [Drives state](#)
- [Controller state](#) (stopped/running)
- [Connection state](#)

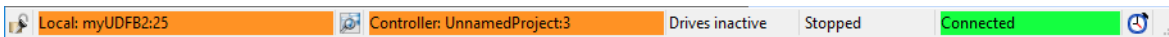



Figure 3-30: Status Bar Labels

An icon  between the Local and Controller versions allows to show any differences (for more details, click here...).

The space on the left of the status bar is reserved for messages.

3.1.13.1 Local Version

This label provides information about the version locally present in the KAS-IDE. There are three different states:

- *Nothing displayed* (for instance when no project is loaded)
- Version information (when available)
- Compilation error (background in **red**)

TIP

Position the mouse over the text field to display a tooltip with the detailed version information.

3.1.13.2 Controller Version

This label provides information about the version present in the controller. There are three different states:

- *Nothing displayed* (when not connected).
- No Application in the controller.
- Version information (when available).
 - Syntax of the version label is: <project_name>:<version>

TIP

When an application is active in the target, you can hold the mouse over the text field to display a tooltip with the detailed version information, including a timestamp of the compilation.

3.1.13.3 Drives State

There are three different states:

- Drives inactive (drives are disabled or your application is not connected to the target)
- Drives active (at least one drive is active)
- Drives error (at least one drive is in error)

3.1.13.4 Controller State

The Controller state label lets you know if the Controller is running or stopped. There are three different states:

- *Nothing displayed* (the label is empty when the KAS-IDE is not connected to the target)
- Controller is stopped
- Controller is running

3.1.13.5 Connection State

The Connection label displays the Connection state between the KAS-IDE and the Controller. There are five different states:

- Not connected
- Connecting
- Connected (background in **green**)
- Connection Error (background in **red**)
- Unexpected Disconnection (background in **red**)

TIP

Hold the mouse over the text field to see a tooltip with some detailed information about the Error and the Controller address when connected.

3.1.13.6 Color Codes

The Local and Controller version labels has an **orange** background if there is a version mismatch between the IDE and the Controller. This warns you that you have to download the new version of the application.

The Local version label has a **red** background if the compilation fails.

[List of use cases for the labels of the status bar](#)

This table summarizes all cases for the labels of the status bar.

Connection Status

Connection State	Local Version	Controller Version	Controller Status	Connection Status
Disconnected				Not Connected
Disconnected	Version A			Not Connected
Connecting	Version A			Connecting...
Connected	Version A	No Application	Stopped	Connected
Connected	Version B	Version B	Stopped or running	Connected
Connected	Version B	Version A	Stopped or running	Connected
Disconnected	Compile error			Not Connected
Connected	Compile error	Version A	Stopped or running	Connected
Comm. error	Version A			Connection Error

Connection State	Local Version	Controller Version	Controller Status	Connection Status
Disconnected	Version A			Unexpected disconnection

4 Getting Started



This section provides explanations and procedures to accomplish common tasks with the KAS-IDE.

4.1 KAS-IDE to Runtime Compatibility

The KAS software includes two main software components, the KAS-IDE and the Runtime .

- The KAS-IDE resides on your PC and the Runtime resides on either the:
 - Programmable automation controller (i.e., PCMM or PCMM2G).
 - Programmable drive (i.e., AKD PDMM).
- For optimum operation, the KAS-IDE installed and run on the PC must be compatible with the Runtime installed on the controller or programmable drive.

The KAS installer and controller Runtime contain the version information in the filename.

Example

NOTE

The version in this text is only an example of the syntax.
The firmware file has a different version number.

```
KAS-Setup-4.02.0.60001.exe
KAS-PCMM-M-M1EC-4.02.0.60001.img
KAS-PCMM-M-MCEC-4.02.0.60001.img
KAS-AKD PDMM-M-M1EC-4.02.0.60001.img
KAS-AKD PDMM-M-MCEC-4.02.0.60001.img
```

The version is determined by:

Version Source	Found From	Example
KAS-IDE, Controller, or Simulator	Help menu > About	<div style="border: 1px solid gray; padding: 5px;"> Product details: General Version: 2. 5 Build 2.5.0.30540 </div>

Version Source	Found From	Example
AKD PDMM	Web server Settings Firmware tab	

The compatibility between the KAS-IDE and the Runtime is defined by matching the digits in the versions.

The KAS-IDE and Runtime use the same version scheme:

```
major . minor . micro . revision
```

- If the KAS-IDE to Runtime major.minor is:
 - NOT equal, they are NOT compatible.
 - Is equal, but the micro is NOT equal, they are not 100% compatible.
- If the KAS-IDE to Runtime major.minor.micro is equal, they are compatible.

Examples

IDE	Runtime	Compatible?	IDE to Runtime Connection
4.02 .xx.xxxx	1.2.xx.xxxx	NO, No connection.	The IDE displays an error message.
4.02 .0.xxxx	4.02.1.xxxx	YES*	Connection possible. The IDE displays warning and requires user to press “ok” to continue.
4.02 .0.xxxx	4.02.0.xxxx	YES	Normal connection.
4.02 .0.30540	4.02 .0.30540	YES	Normal connection.

*Not a recommended configuration.

The IDE will operate, but there can be different features available between the IDE and the Runtime. It is recommended to upgrade either the IDE or the Runtime to matching versions.

4.2 KAS PLC Code to Runtime Compatibility

It is possible that after a Controller Runtime upgrade that the Runtime and the compiled project versions `major.minor.micro` may be different. The Runtime will not start if there is an incompatibility between the versions.

AKD PDMM or PCMM	An E24 error will be displayed and an error will be logged if compiled project version is incompatible with the Runtime version.
PAC	An error will be logged if the compiled project version is incompatible with the Runtime version.

To correct the incompatible versions, either re-compile and download the KAS project file using the same IDE version as the Runtime version OR change the Controller's Runtime version to match the compiled project's version.

4.3 KAS-IDE to Project File Compatibility

This section helps describe forwards and backward compatibility between the KAS-IDE and project files.

About Backward Compatibility

The KAS-IDE is backward compatible, meaning the KAS-IDE can open project files made with older versions of the software. There are a few things to note.

- An "older" project file will be converted to take advantage of features in the newer version.
- As there may be multiple conversions needed to update the file, if any step is not backward compatible you will be warned with a pop-up message and the process will continue with the next conversion step.
- You can exit without saving the project conversion.
- You may use the "Save As" function to make a copy of the newly converted project file, preserving the original.

About Forward Compatibility

The KAS-IDE strives to be forward compatible, meaning it can open project files made with newer versions of the software. If there are no compatibility issues, the KAS-IDE will simply open the file.

4.4 Start the KAS-IDE

There are multiple ways to start the KAS-IDE.

- Double-click a desktop shortcut.
- Double-click a project file to open it with the most recently installed version of the KAS-IDE.
- **Windows 10 and 11:** From the Start menu, under "K".
 - All installed versions are found here, including one legacy version (in the Kollmorgen folder), and all installed versions of v3.01 and later.
 - See "Can I install more than one version of the KAS-IDE?" (→ p. 823) for more information.

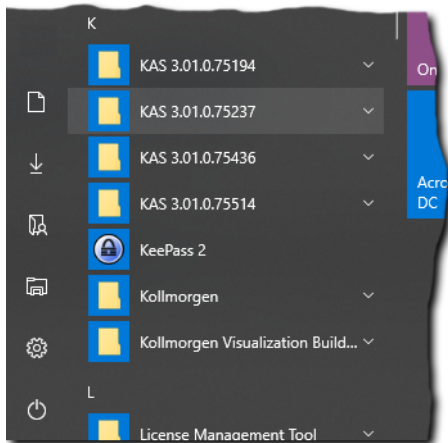

TIP

The KAS-IDE supports simultaneously running multiple instances. Double-click a shortcut or project file, or selecting the application from the Start menu opens another instance. Double-click a project file more than once opens a copy of the project in another instance of the KAS-IDE.

See the these FAQs for more options:

- "How do I launch my project with a particular version of the KAS-IDE?" (→ p. 824)
- "How do I choose the default version of the KAS-IDE to use?" (→ p. 824)

4.4.1 Find the KAS-IDE Version

The version of the KAS-IDE or KAS Simulator being used is visible in the title bar of the application.

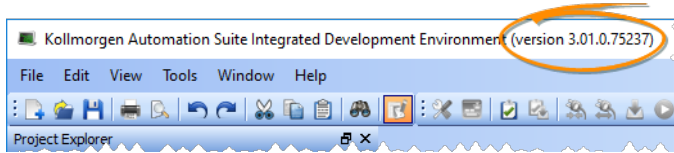

Click the **About** command in the **Help** menu to view this information.

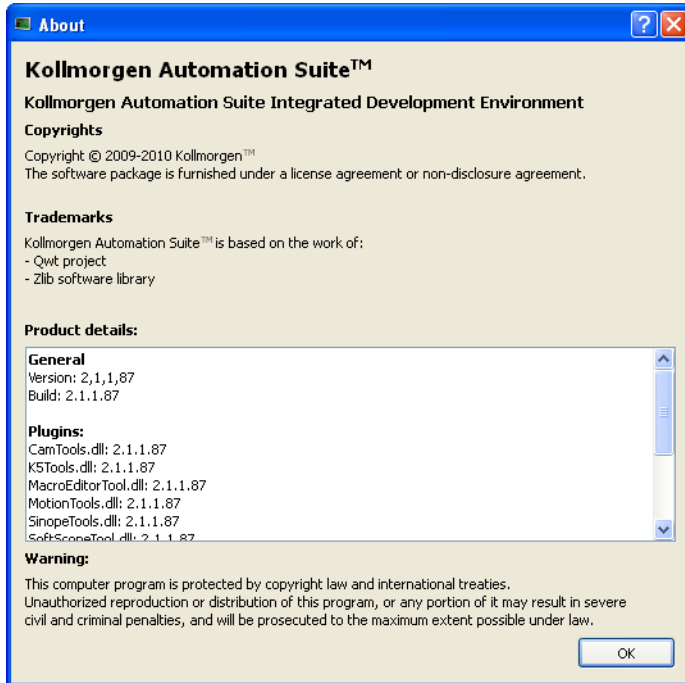

Figure 4-1: About Window

This window displays the application versions as well as all the plug-in versions included in the KAS-IDE and loaded during start up.

4.4.2 Access Help System

Access the online help using the **Documentation** command in the **Help** menu.

See Use the Context-Sensitive Help for more information.

4.4.3 KAS GUI

For a better understanding of **KAS** menus, toolbar and workspace items (description and manipulation), see "Describing the KAS Graphical User Interface" (→ p. 70).

4.4.4 KAS-IDE Log Window

4.4.4.1 Log Information

The KAS log window (see Figure: "**Log Messages**") provides a running display of activity related to the execution of the application. Items displayed include application startup and initialization information.

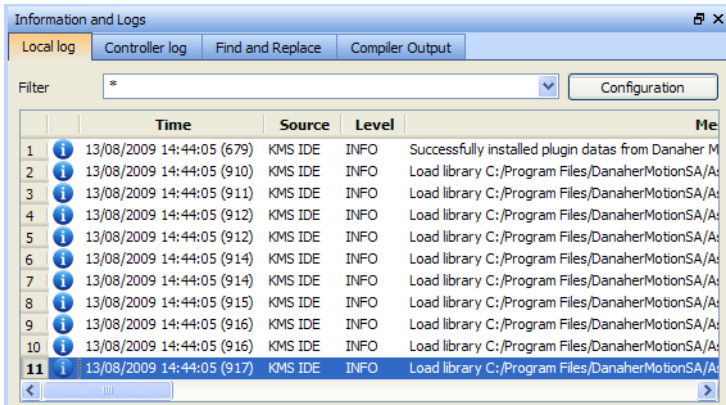

Figure 4-2: Log Messages

also see "Information and Logs window" on page 102

4.4.5 Create a Project

There are six basic aspects of setting up a KAS project.

1. Setting up the controller
2. Setting up the drives.
3. Defining the remote I/O.
4. Setting up the EtherCAT Motion Bus
5. Creating the program in the KAS-IDE.
6. Setting up the HMI panel.

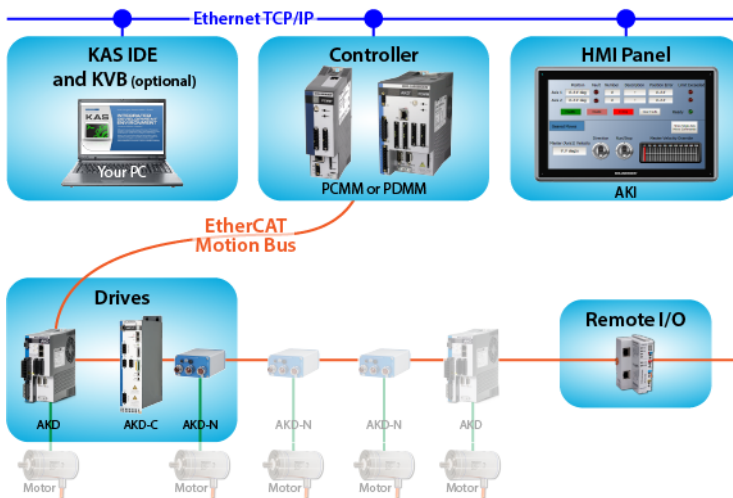

4.4.6 Add and Configure a Controller

4.4.6.1 Add the Controller

1. In the **File** menu, click **New** to start the Controller Creation Wizard.
2. Select the type of controller in the project.

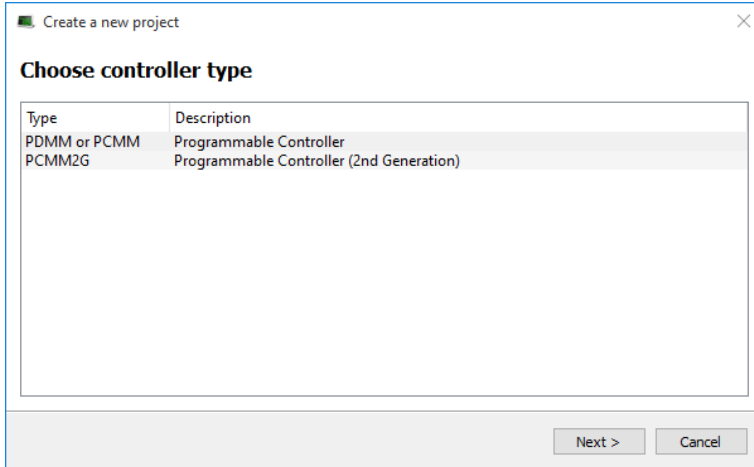

3. Choose the motion engine option and select the application template. See the "Available Application Templates" (→ p. 133) list.

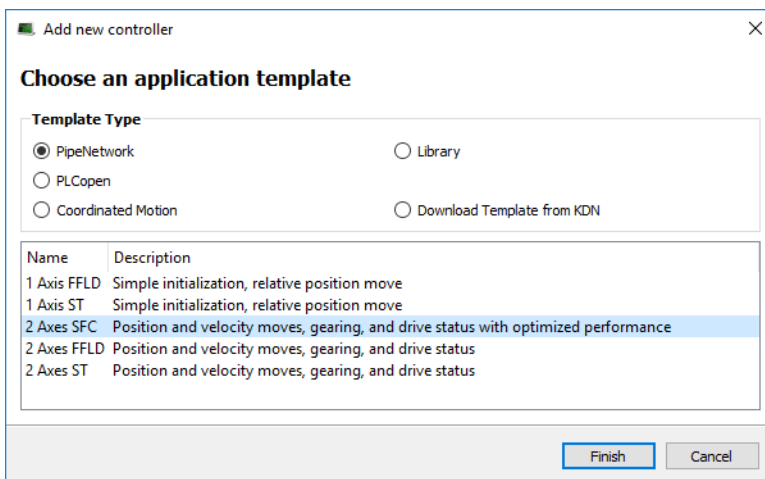

4. Click **Finish**.
5. In the **File** menu, click **Save As**.
6. Define the Project Name and its location.
7. Click **OK**.

4.4.6.1.1 Available Application Templates

List of available application templates

- "Coordinated Motion" (→ p. 133)
- "KAS Runtime" (→ p. 134)
- "KDN Download" (→ p. 134)
- "Pipe Network" (→ p. 134)
- "PLCopen" (→ p. 134)

4.4.6.1.2 Coordinated Motion

Template Name	Description
"Coordinated Motion - 2-Axis Template" (→ p. 636)	<ul style="list-style-type: none"> • Linear / Circular • Raster Scan Motion Path • 2 PLCopen axes
"Coordinated Motion - 3-Axis Template" (→ p. 637)	<ul style="list-style-type: none"> • Linear / Circular • Raster Scan Motion Path • 1 Pipe Network axis • 2 PLCopen axes
"Coordinated Motion - 3-Axis (3D) Template" (→ p. 638)	<ul style="list-style-type: none"> • Linear 3D • Diamond / Square Motion Path • 3 PLCopen axes

4.4.6.1.3 KAS Runtime

Template Name	Description
Library	Used to create a custom library. See also see "Create and Use Custom Libraries" on page 209.

4.4.6.1.4 KDN Download

Template Name	Description
KDN	<ol style="list-style-type: none"> 1. Click Finish to close the dialog. A web browser page opens on KDN with custom-built template files. The template files may have enhanced or specific functionality. 2. Download and save a template file. 3. Open it from KAS-IDE.

4.4.6.1.5 Pipe Network

Template Name	Description
"Pipe Network 1-Axis Template - FFLD" (→ p. 641)	Simple initialization, relative position move.
"Pipe Network 1-Axis Template - ST" (→ p. 641)	Simple initialization, relative position move.
"Pipe Network 2-Axes Template - FFLD" (→ p. 650)	Position and velocity moves, gearing, camming, and drive status.
"Pipe Network 2-Axes Template - ST" (→ p. 647)	Position and velocity moves, gearing, camming, and drive status.
"Pipe Network 2-Axes Template - FBD, FFLD, SFC, and ST" (→ p. 642)	Position and velocity moves, gearing, camming, and drive status with optimized performance.

4.4.6.1.6 PLCopen

Template Name	Description
"PLCopen 1-Axis Template - FFLD" (→ p. 653)	Simple initialization, relative position move.
"PLCopen 1-Axis Template - ST" (→ p. 654)	Simple initialization, relative position move.

Template Name	Description
"PLCopen 2-Axes Template - FFLD" (→ p. 663)	Position and velocity moves, gearing, camming, and drive status.
"PLCopen 2-Axes Template - ST" (→ p. 659)	Position and velocity moves, gearing, camming, and drive status.
"PLCopen 2-Axes Template - FFLD and SFC" (→ p. 655)	Position and velocity moves, gearing, camming, and drive status with optimized performance.

4.4.6.2 Configure the Controller

The controller is configured using the **Controller Properties** dialog box.

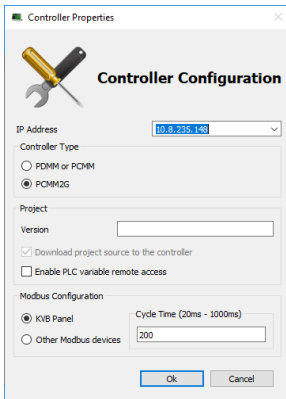

Procedure

1. In the Project Explorer, right-click the new controller to open the menu and click **Properties**.
2. Choose the Controller Type.

ⓘ IMPORTANT

The correct Controller Type must be selected before compiling the application. This is because the PLC code generated for the AKD PDMM or PCMM controls and the PCMM2G have different endianness. AKD PDMM / PCMM files are [big endian](#). PCMM2G files are [little endian](#). A warning opens if the application is started with an incompatible controller type.

3. Define the IP Address.

IP Addresses

- For the KAS Runtime Simulator, enter the local host IP address: 127.0.0.1.
- For the AKD PDMM or PCMM enter the IP address of the controller (e.g., 10.155.100.150).
 - The default IP address is 192.168.0.1.
 - This is the same default IP address on the PCMM or AKD PDMM controllers.

NOTE

Verify that controller is accessible by the KAS-IDE machine. See FAQ "Setup" (→ p. 833) for IT issues.

ⓘ IMPORTANT

Do not use leading zeroes when entering an IP address. The connection to the controller automatically fails if leading zeroes are used. **Example:** Use **10.2.3.40** instead of **010.002.003.040**.

4. Optional: Specify a version number (the string can be composed of any character).

🔧 TIP

Versioning is useful to make improvements to the application and if a version control system is needed. The version is saved in your project file.

5. Optional: Choose whether the project's source code should be downloaded to the controller.
This is enabled by default and your preference is saved with the project.
Disabling this option means a comparison of source on the controller and in the IDE is not available.
6. Optional: Choose whether PLC variables are read/written via an HTTP connection.
This requires that the source be downloaded to the controller.
By default this option is disabled so unauthorized changes may not be made.

 **TIP**

Recompile the project before downloading it to the controller.

7. Select whether Modbus goes to a KVB Panel or is handled by another Modbus device.
8. Set the **Cycle Time** (i.e., the communication update frequency).
See "Modbus Slave" (→ p. 594) for more information.

NOTE

- If KVB Panel is selected there will be no node to add a Modbus configuration in the Fieldbus Editor.

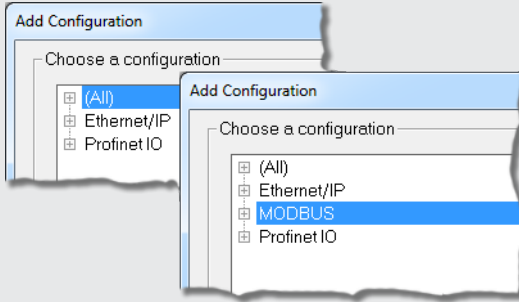

- If Other Modbus devices is selected then the KVB checkbox for Dictionary items will be hidden. Motion configuration will need to be added from the Fieldbus Editor.

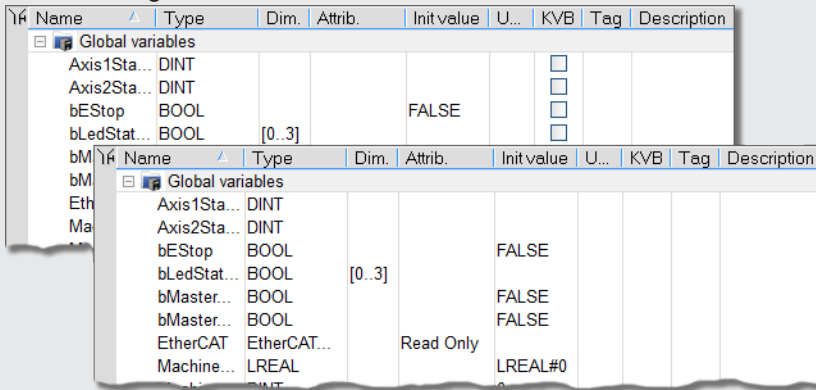

9. Click **OK**.

4.4.7 Configure EtherCAT Motion Bus

TIP

Before configuring the EtherCAT settings, you may want to add third party EtherCAT devices. See "Add and Configure Third Party Devices" (→ p. 204) for more information.

Double-click the **EtherCAT** node in the Project Explorer to open the EtherCAT properties dialog in the workspace.

This window has these tabs:

Tab	Description
"EtherCAT Devices tab" (→ p. 322)	Displays all the E-Bus devices present in the project tree.
"EtherCAT Master Settings tab" (→ p. 327)	Used to configure the EtherCAT bus master.
"ENI File tab" (→ p. 329)	Used for an external configuration file.
"ESI Files tab" (→ p. 330)	Display, add, and remove available ESI files.

KAS includes an integrated tool to configure the EtherCAT [master](#) and start up the fieldbus operation.

Use the configuration tool to:

- Describe your motion "Topology" (→ p. 792) as a configuration tree.
 - See the procedure in "EtherCAT Devices tab" (→ p. 322).
- Associate variables to the I/O channels of devices.
 - See the procedure in "Map Input and Output to Variables" (→ p. 314).

4.4.7.1 Slave Devices

Slave devices can support several PDOs.

NOTE

PDOs contain real-time cyclic data which is deterministic.
Non-cyclic data is not deterministic and is defined by Service Data Objects (ScDO).

In "EtherCAT Motion Bus Concepts" (→ p. 786), input and output parameters are grouped in predefined blocks called PDOs.

- Some PDOs are mandatory; others are optional.
 - See [click here...](#) for the list.
- One of the main tasks of the EtherCAT configuration is to select the PDOs used by each slave and group them all in the EtherCAT image.
 - See "EtherCAT Devices Summary Form" (→ p. 323) for more information.

4.4.7.2 EtherCAT Scan and Association

Physical EtherCAT devices, modules, couplers, and slices are discovered during the **Scan Devices** routine and are automatically set as project devices in the Project Tree.

- These device associations persist through subsequent scans unless you change them.
- The **Scan Devices** is accessed by double-clicking the EtherCAT node in the Project Explorer, then pressing the **Scan Devices** button in the **Devices** tab.

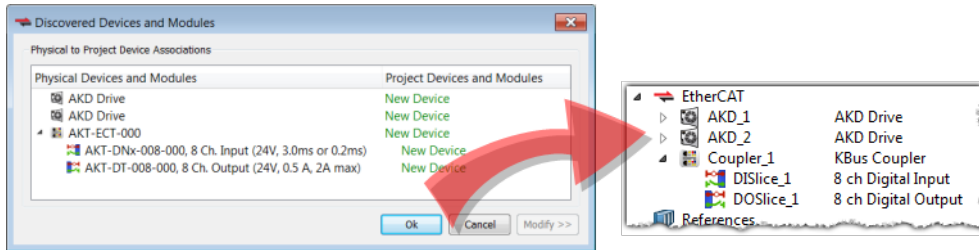

Changing the network's physical topology (by adding moving, or removing devices) or changing the associations between physical devices and project devices will require that **Scan Devices** be run again. The **Discovered Devices and Modules** window will display any changes and the **Modify** button will be enabled. When **Modify** is clicked the dialog box expands to show Available Project Devices and Modules. Click on a device and drag it to the corresponding **New Device** to create an association. Repeat as necessary for slices and modules.

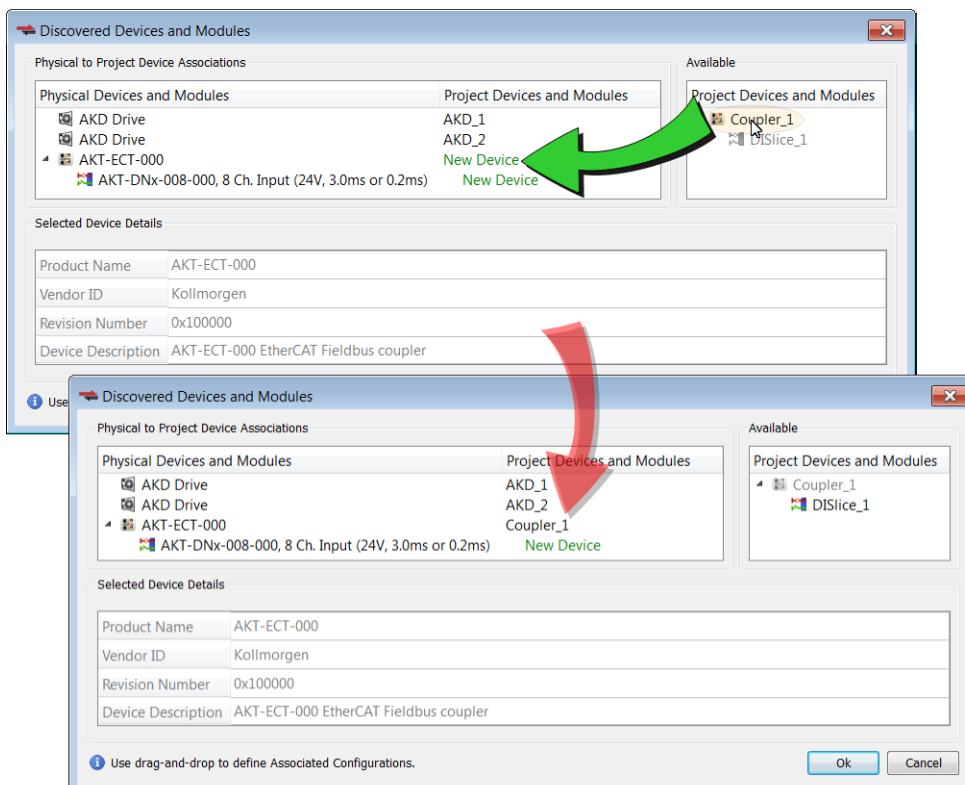

Once the associations are complete, click **Ok**. See the following procedures for more details.

- New projects with no project devices: "Scan and Associate Network Devices" (→ p. 140). This creates default configurations for the discovered physical devices/modules and couplers/slices.
- Adding, removing, or moving devices: "Re-Scan and Change Device Associations" (→ p. 143).
- Adding, removing, or moving couplers with slices: "Re-Scan and Change Coupler/Slice Associations" (→ p. 145).
- Adding, removing, or moving devices with modules: "Re-Scan and Change Device/Module Associations" (→ p. 149).

The physical network topology will be compared to the project's expected network topology after the EtherCAT devices are associated and the PLC application is started. An error will be reported if the topologies do not match and the PLC program will not run.

NOTE

The physical topology must match the project's expected topology for the PLC application to operate the devices properly.

4.4.7.3 Scan and Associate Network Devices

To discover the physical EtherCAT devices, follow these steps:

1. In the Project Explorer, double-click the **EtherCAT** node to open the **Devices** tab. If there are no devices, the EtherCAT network topology has not yet been scanned and discovered.
2. In the **Devices** tab, click the **Scan Devices** button.

NOTE

The topology discovery is only enabled when the controller is not running an application.

- If the scan process fails, refer to the "EtherCAT Error Messages" (→ p. 846).

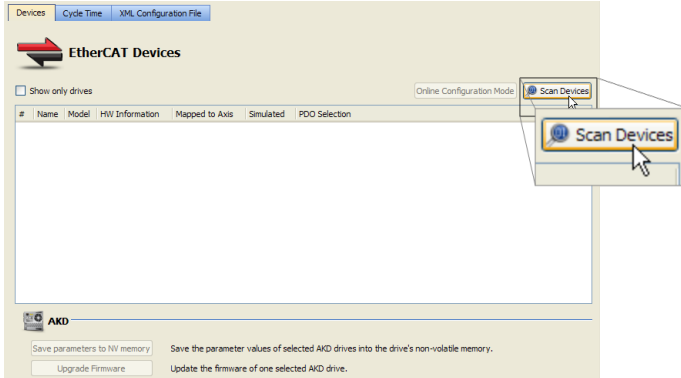

- If physical devices are discovered during the scan, they will appear under the Physical Devices column.

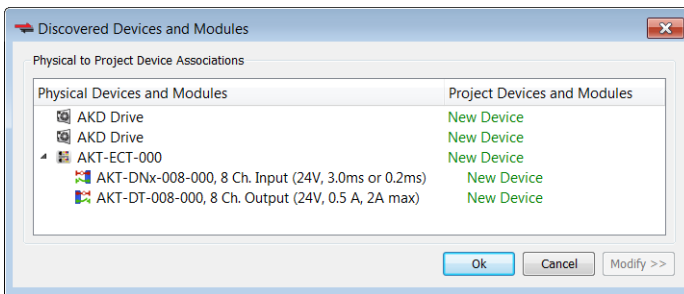

3. Press **OK**. The devices will appear in the **Devices** tab and in the **Project Explorer**. Their associated project devices are set to the defaults.
4. If you have previously compiled your project, you will be asked if you wish to recompile the project.

TIP

If you click **Scan Devices** again, the existing project devices will be automatically matched to the same physical devices. The association will not be lost from rescanning.

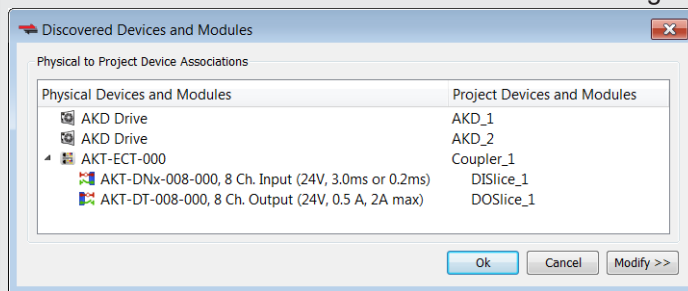

To change the device associations see "Re-Scan and Change Device Associations" (→ p. 143).

To troubleshoot an error due to a missing ESI file, please see "Unknown – Missing ESI File" (→ p. 141).

4.4.7.3.1 Unknown – Missing ESI File

The **Discovered Devices and Modules** view will identify a device as "Unknown" if a corresponding ESI file is not found during the Scan for physical EtherCAT devices. For example, the last three devices are missing ESI files:

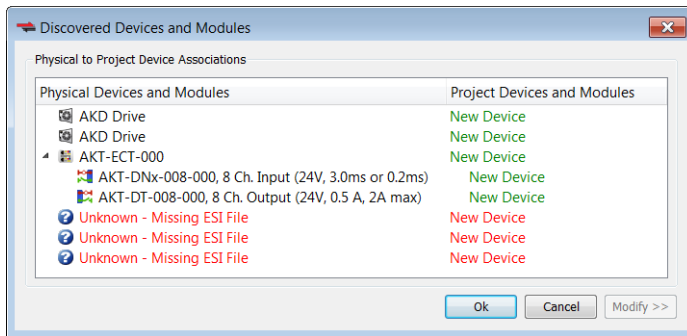

Click on the **Ok** button and the Unknown devices will be added to the Project View:

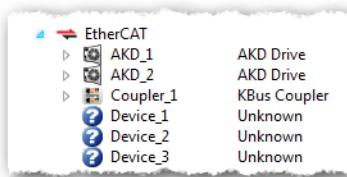

To correct the problem:

1. Double-click on the "Unknown" device in the Project View or right-click and select **Properties**.
2. From the General Properties view, identify the **Vendor**, **Product Code**, and **Revision Number**.

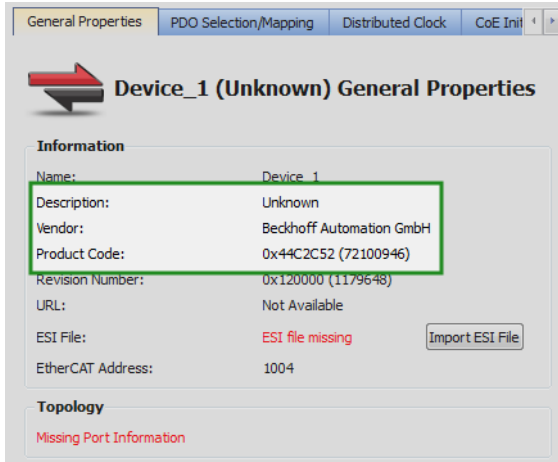

3. Contact the vendor for the EtherCAT ESI file for this device.

The vendor may provide an ESI file that supports multiple devices or they may provide a separate ESI file for each device.

4. Import the ESI file using the **Import ESI File** button and the device specific information will be automatically updated in the Project View and General Properties.

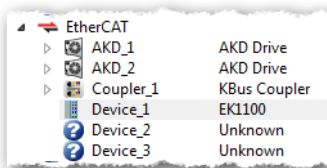

4.4.7.3.2 Missing ESI File - MDP Device

During the Scan for physical EtherCAT devices, if a MDP device is discovered that does not have a corresponding ESI file, then the **Discovered Devices and Modules** view will identify the device as “Unknown” and will not be able to discover any modules under the device. For example, the last device is missing an ESI file:

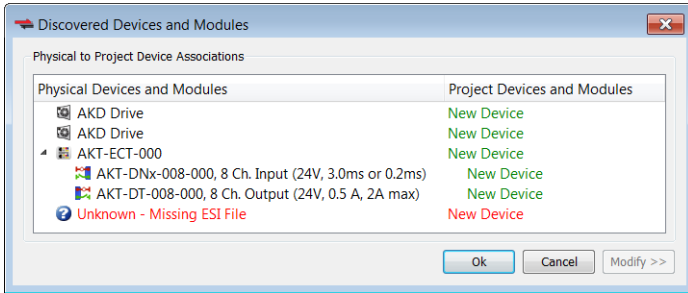

Click on the **Ok** button and the **Unknown** device will be added to the Project View.

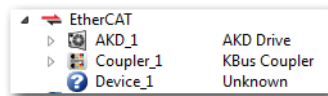

To correct the problem:

1. Double-click on the “Unknown” device in the Project View or right-click and select **Properties**.
2. From the General Properties view, identify the **Vendor**, **Product Code**, and **Revision Number**.

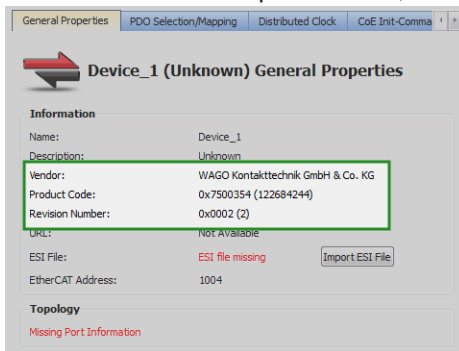

3. Contact the vendor for the EtherCAT ESI file for this device. The vendor may provide an ESI file that supports multiple devices or they may provide a separate ESI file for each device.
4. Import the ESI file using the **Import ESI File** button. A pop-up message will indicate that this a MDP device and the EtherCAT network must be scanned to re-discover the modules:

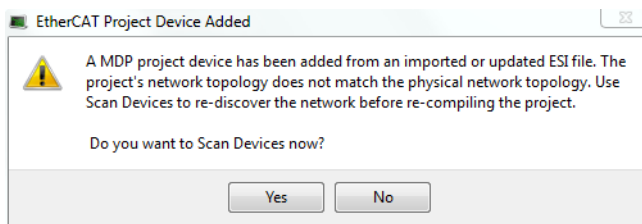

After the scan and association of devices/modules, the MDP device and its modules will be added to the Project View:

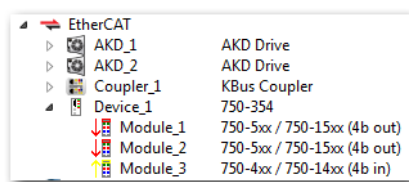

4.4.7.4 Re-Scan and Change Device Associations

Device Association must be updated after the following actions.

- Changing the physical network topology by adding, moving, or removing EtherCAT devices.

⚠ CAUTION

Changing the EtherCAT network topology (plugging and unplugging EtherCAT cables) is supported while power is supplied. Personal injury or damage to devices may occur if EtherCAT devices are installed, wiring is changed, or the terminal configuration is changed while power is supplied ("hot swapping").

- If you want to change the associations between devices and configurations.
- Changing the FSoE address via physical switch settings (DIP switches, rotary switches, etc.) for Safety devices.

To update the associations:

1. Re-scan and re-discover the physical network topology.
2. Click the **Modify** button to expand the Discovered Devices and Modules view.
3. Drag-and-drop the project coupler and/or slice(s) to associate them with the physical couplers/slices.

For example, a project has the following configuration:

- The first AKD Drive and a I/O Coupler were created during a previous scan
- The second AKD was added to the project manually, and is not yet associated with any physical drive

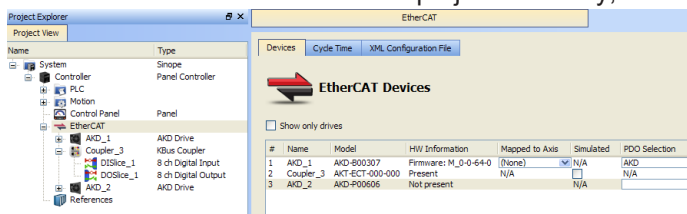

To update the network topology:

1. In the Project Explorer, double-click the EtherCAT node to open its **Properties** and click the **Scan Devices** button in the Devices tab.
Alternatively, right-click on the EtherCAT node in the Project Explorer and select **Scan Devices**.

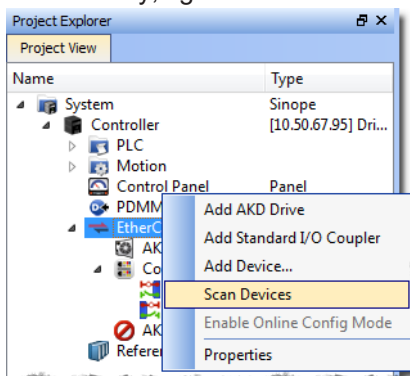

2. The Discovered Devices and Modules dialog box appears after a successful scan.

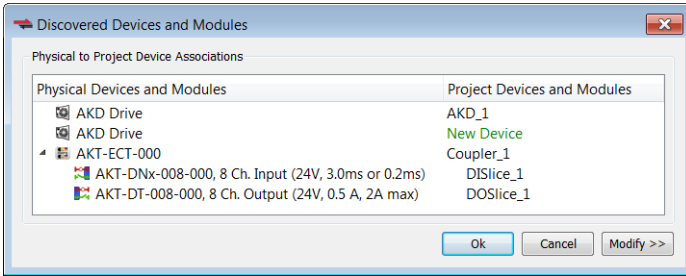

3. Click the **Modify** button to open the expanded view.

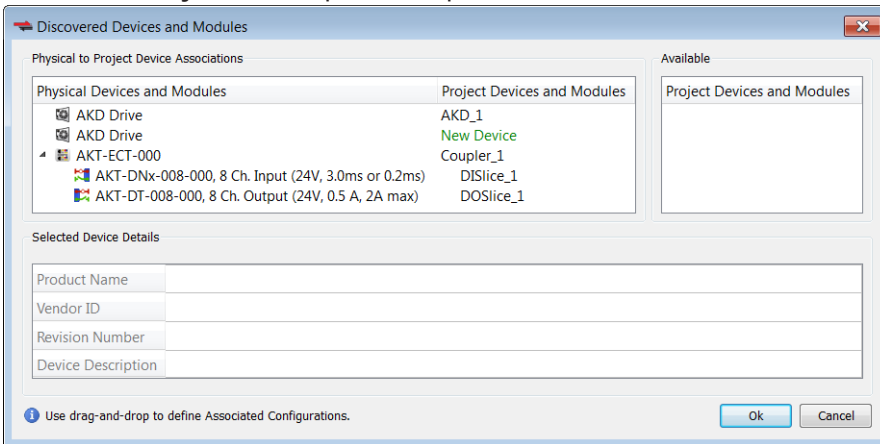

4. Drag-and-drop **AKD_2** from **Available** to the second physical AKD drive. This associates the project device to the physical device.

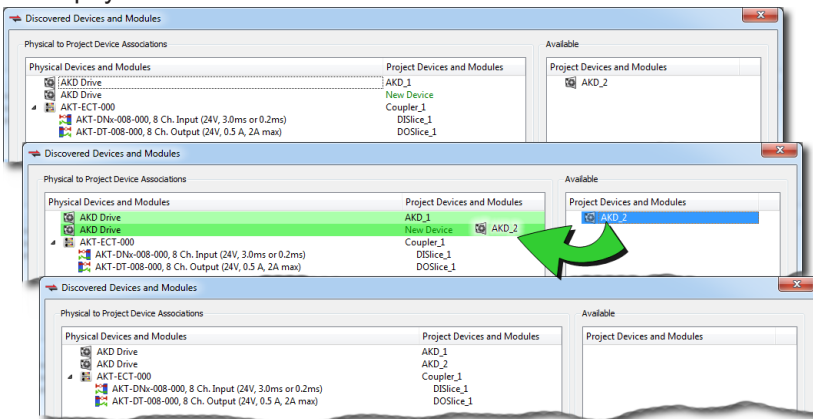

5. Click **OK** to confirm the modified association.

6. If you have previously compiled your project, you will be asked if you wish to recompile the project.

The KAS-IDE automatically reorders the EtherCAT nodes and the I/O terminals in the Project Explorer to match the physical device order on the network. The following figures show the Project View before and after associating devices.

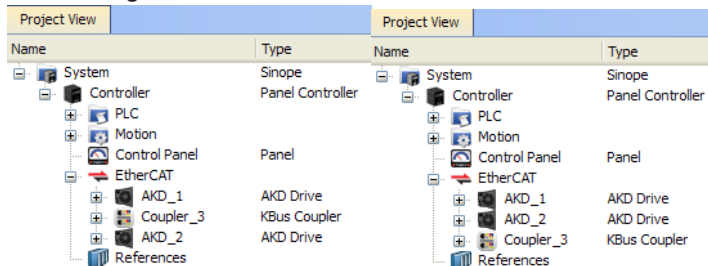

4.4.7.5 Re-Scan and Change Coupler/Slice Associations

Coupler or slice associations must be updated after the following actions.

- Changing the physical network topology by adding, moving, or removing I/O slices attached to an EtherCAT coupler
- Changing the associations between physical and project I/O slices.

To update the associations:

1. Re-scan and re-discover the physical network topology.
2. Click the **Modify** button to expand the Discovered Devices and Modules view.
3. Drag-and-drop the project coupler and/or slice(s) to associate them with the physical couplers/slices.

ⓘ IMPORTANT

After changing the association of an EtherCAT device, you have to recompile the project and download this new version to save your modifications on the target.

4.4.7.5.1 EtherCAT Scan & Association Example 1 - Associating Couplers and I/O Slices

In this example the project has the following configuration:

- Two AKD drives which were created during a previous scan
- A coupler and I/O slice were manually added to the project but are not yet associated with the physical coupler and I/O slice.

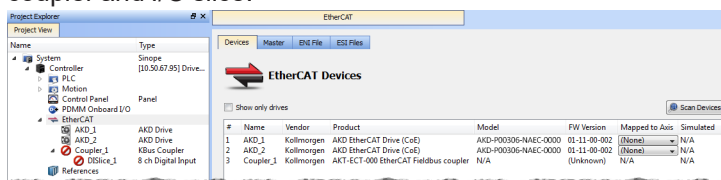

To update the network topology:

1. In the Project Explorer, double-click the EtherCAT node to open its Properties and click the Scan Devices button in the Devices tab.

Alternatively, right-click on the EtherCAT node in the Project Explorer, and select Scan Devices.

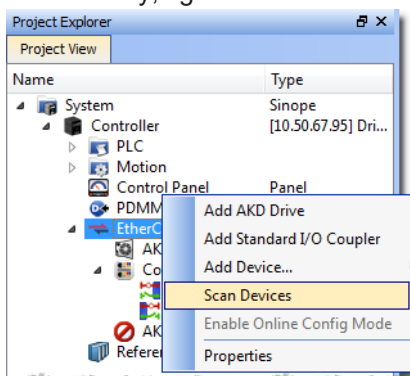

2. The Discovered Devices and Modules dialog box appears after a successful scan.

3. Click the Modify button to open the expanded view.

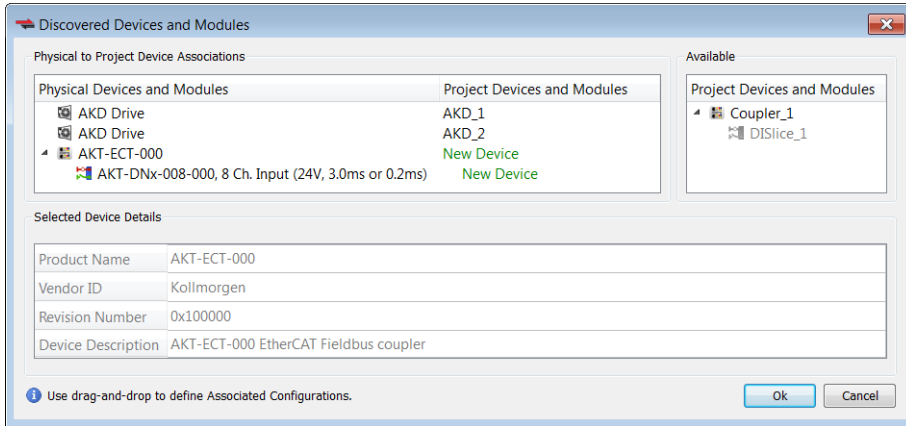

4. To associate the project coupler and I/O slice to the physical coupler and I/O slice:
 1. Drag-and-drop Coupler_1 from Available to the physical coupler (AKT-ECT-000).

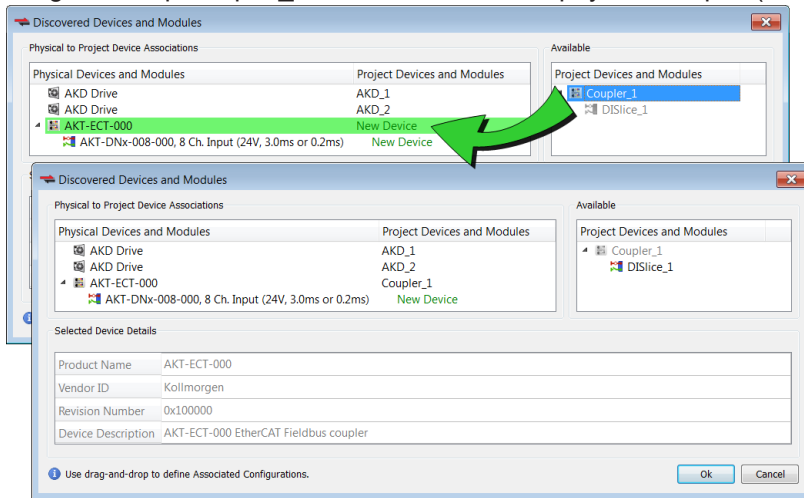

2. Drag-and-drop DISlice_1 from Available to the physical I/O slice (AKT-DNx-008-000).

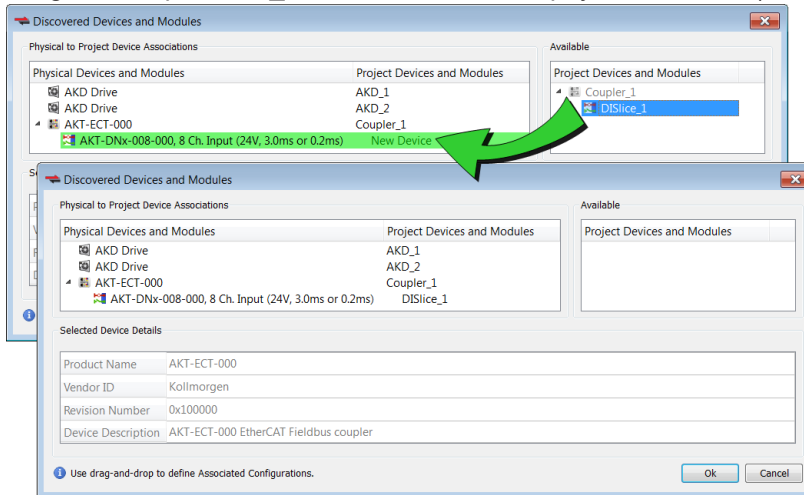

5. Click OK to confirm the modified associations.

The KAS-IDE updates the EtherCAT nodes for the coupler and I/O slice in the Project Explorer to match the physical coupler and I/O slice.

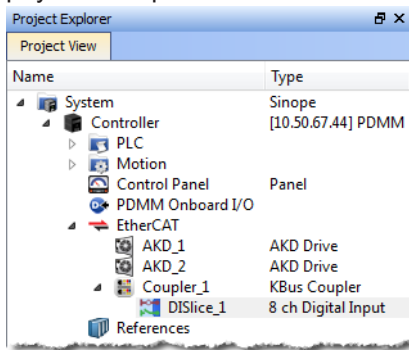

4.4.7.5.2 EtherCAT Scan & Association Example 2 - Adding Physical I/O Slices

In this example another physical I/O slice is added to the coupler.

To update the network topology:

1. In the Project Explorer, double-click the EtherCAT node to open its Properties and click the Scan Devices button in the Devices tab.

Alternatively, right-click on the EtherCAT node in the Project Explorer, and select Scan Devices.

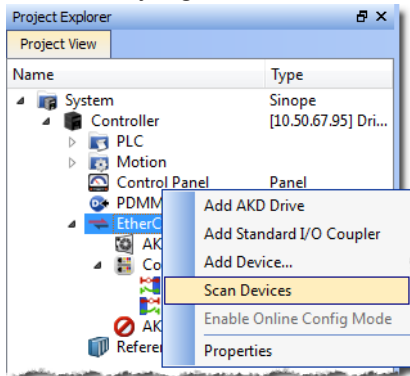

2. The Discovered Devices and Modules dialog box appears after a successful scan.
3. Click the Modify button to open the expanded view.

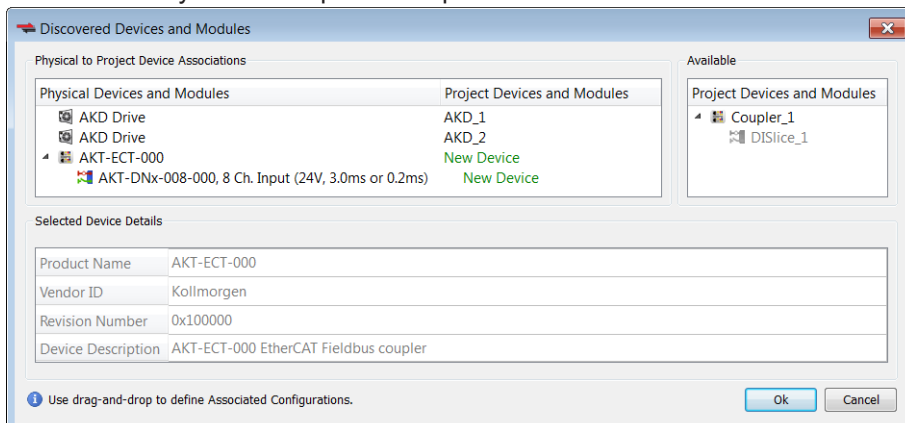

4. To associate the coupler and I/O slice configurations with the physical coupler and I/O slice:
 1. Drag-and-drop Coupler_1 from Available to the physical coupler (AKT-ECT-000).

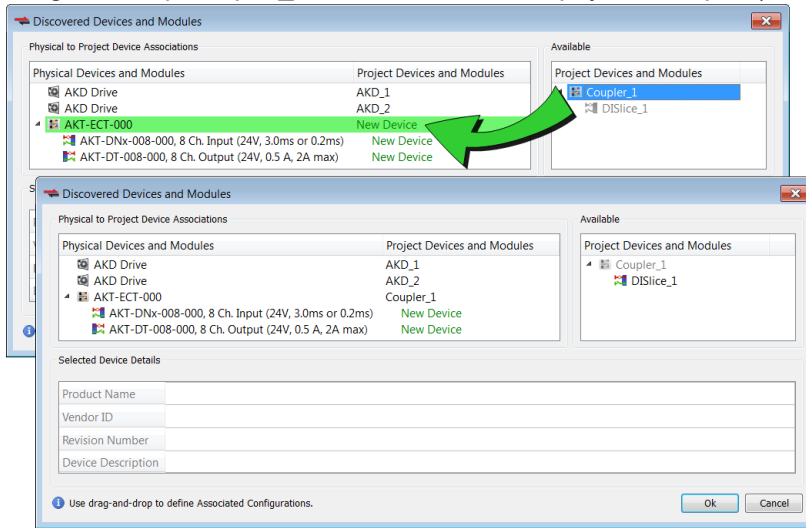

2. Drag-and-drop DISlice_1 from Available to the physical I/O slice (AKT-DNx-008-000).

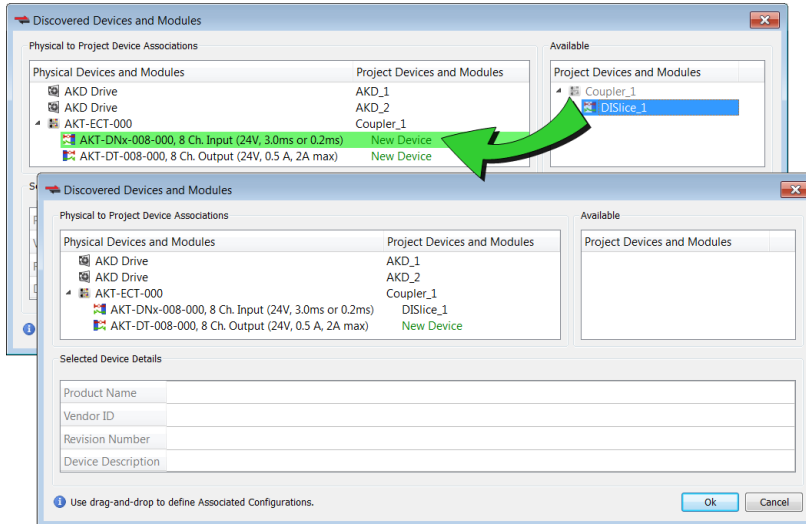

5. Click OK to confirm the modified association.

The KAS-IDE creates the EtherCAT node for the added I/O slice in the Project Explorer to match the physical I/O slice:

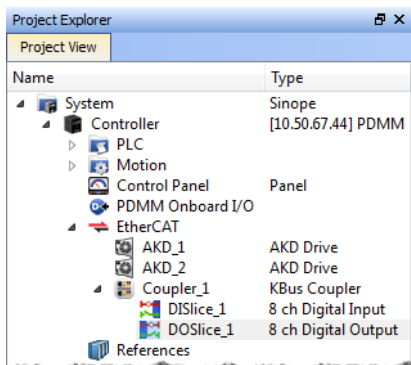

4.4.7.6 Re-Scan and Change Device/Module Associations

Device or module associations must be updated after the following actions.

- Changing the physical network topology by adding, moving, or removing modules attached to an EtherCAT modular device.
- Changing the associations between a physical module and a project module.

To update the associations:

1. Re-scan and re-discover the physical network topology.
2. Click the **Modify** button to expand the Discovered Devices and Modules view.
3. Drag-and-drop the project coupler and/or slice(s) to associate them with the physical couplers/slices.

ⓘ IMPORTANT

After changing the association of an EtherCAT device, you have to recompile the project and download this new version to save your modifications on the target.

NOTE

A MDP device's configurable properties (PDO selections/content, PLC variable maps, and CoE Init-Commands) are determined by the modules under the device. The default values for the device's configuration are determined from the ESI file.

The device's configuration can be modified from the KAS-IDE EtherCAT device configuration tabs. Although the project modules cannot be configured directly, they can be associated with Physical modules by dragging-and-dropping them in the Discovered Devices and Modules view.

When a project module is associated with a Physical module, its configuration (PDO selections/content, PLC variable maps, and CoE Init-Commands) is automatically updated at the device level. The order of the modules under the device, is determined by order the Physical modules are discovered. The order of CoE Init-Commands also follows the order of the Physical modules. This includes any user specified CoE Init-Commands.

It is recommended to check the CoE Init-Command ordering after changing module associations, to verify it still meets any user-specific ordering requirements.

4.4.7.6.1 EtherCAT Scan & Association Example 3 - Add a Module to a Device

In this example a module is added to the device on the physical network:

- A device with a module which was created during a previous scan.

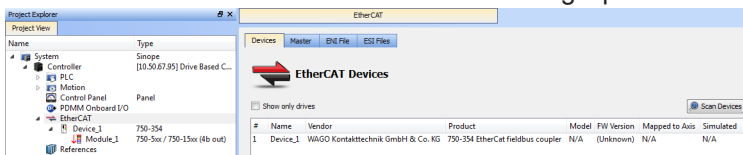

- Another module needs to be added to match the device on the physical network.

To update the network topology:

1. In the Project Explorer, double-click the EtherCAT node to open its Properties and click the Scan Devices button in the Devices tab.
Alternatively, right-click on the EtherCAT node in the Project Explorer, and select Scan Devices.

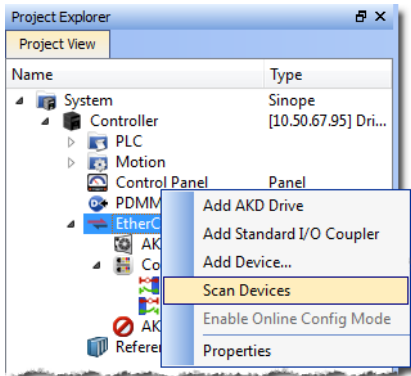

2. The Discovered Devices and Modules dialog box appears after a successful scan.
3. Click the Modify button to open the expanded view.

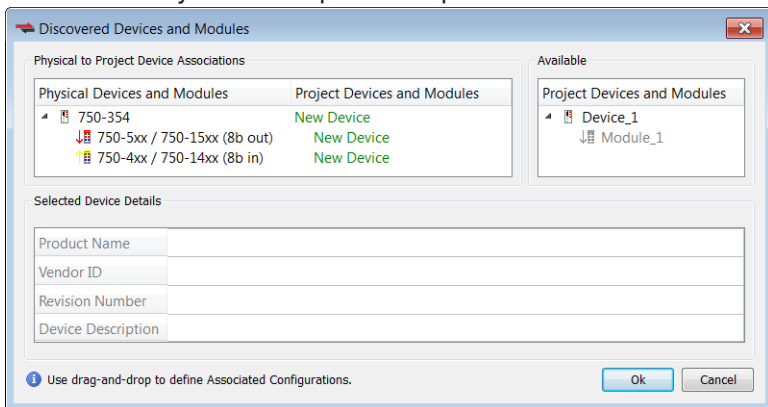

4. To associate the project device and module to the physical device and module:
 1. Drag-and-drop Device_1 from Available to the physical device (750-354).

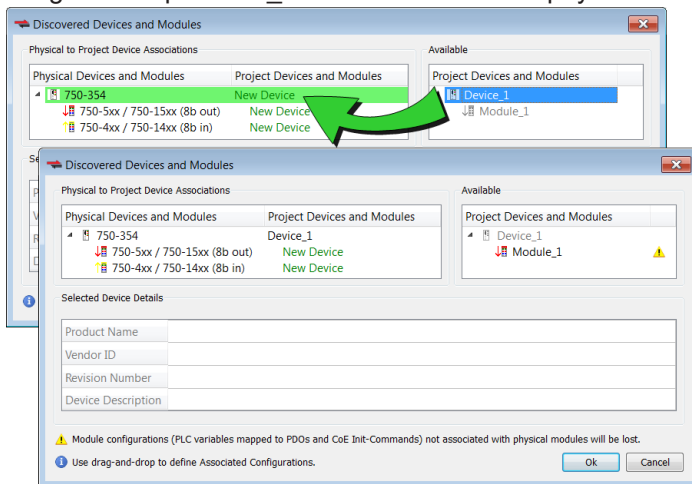

2. Drag-and-drop Module_1 from Available to the physical module (750-5xx).

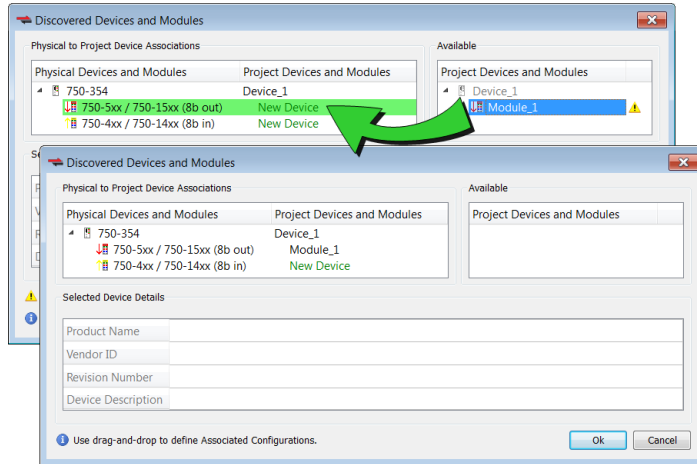

5. Click OK to confirm the modified associations.

The KAS-IDE updates the EtherCAT nodes for the device and modules in the Project Explorer to match the physical device and modules.

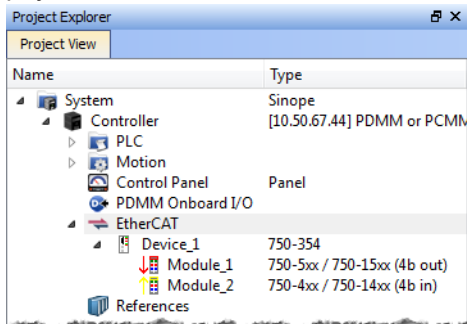

4.4.7.6.2 EtherCAT Scan & Association Example 4 - Remove a Module From a Device

In this example a module is removed from the device on the physical network.

To update the network topology:

1. In the Project Explorer, double-click the EtherCAT node to open its Properties and click the Scan Devices button in the Devices tab.

Alternatively, right-click on the EtherCAT node in the Project Explorer, and select Scan Devices.

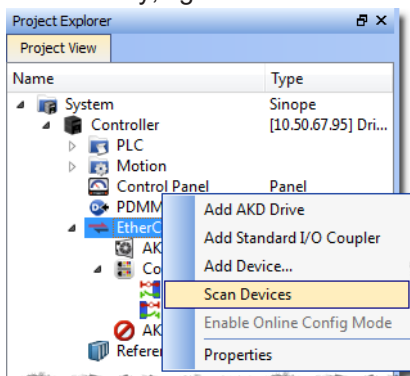

2. The Discovered Devices and Modules dialog box appears after a successful scan.

- Click the Modify button to open the expanded view. Note that there are two modules (Module_1 and Module_2) under Device_1 in Available, but there is only one physical module.

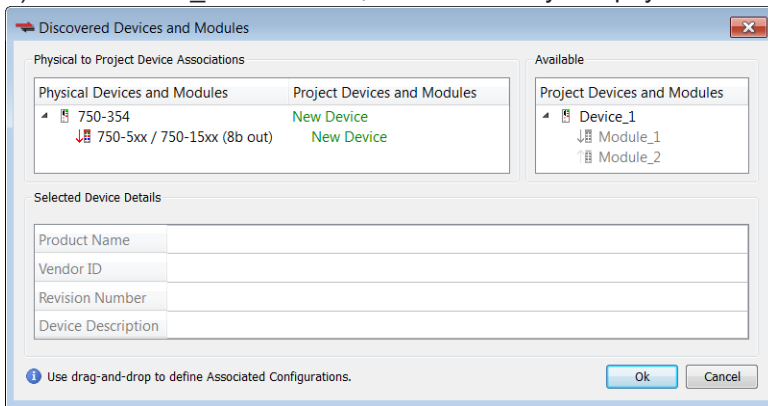

- To associate the project device and module to the physical device and module:
 - Drag-and-drop Device_1 from Available to the physical device (750-354).

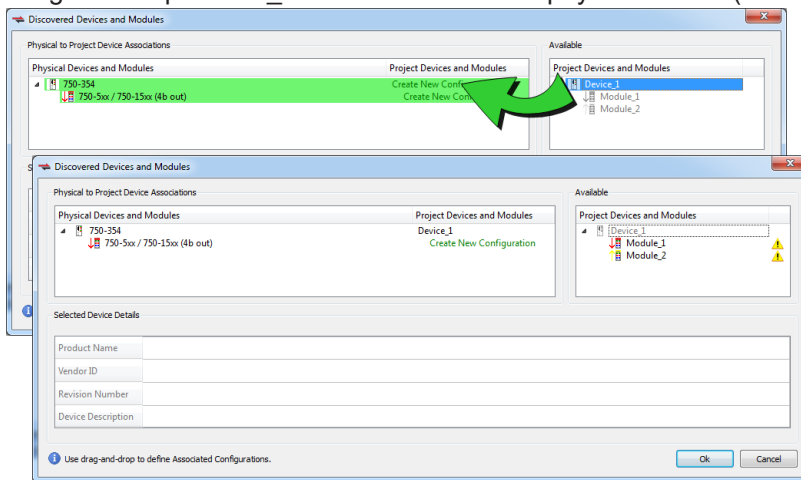

- Drag-and-drop Module_1 from Available to the physical module (750-5xx).

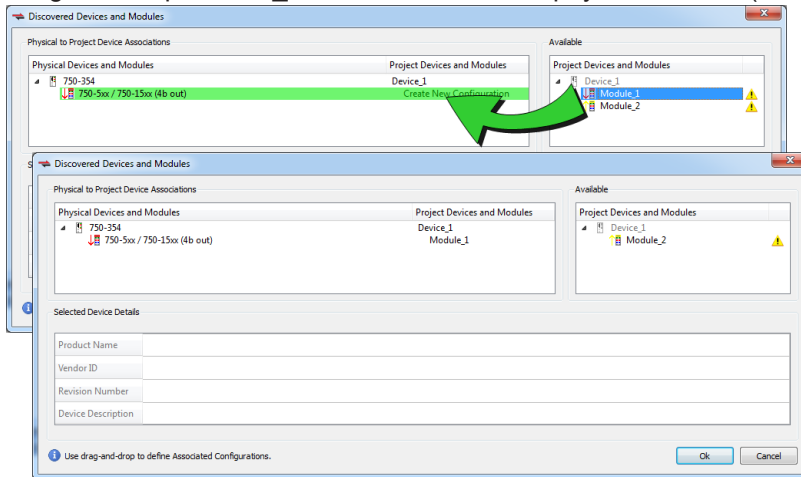

NOTE

Module_2 cannot be associated with a physical module. This is because there are no compatible Physical modules available. Module_2 and any of its user configuration settings will be lost when the OK is clicked.

- Click OK to confirm the modified configuration. Module_2 is automatically deleted.

The KAS-IDE creates the EtherCAT node for the device and modules in the Project Explorer to match the physical device and modules. Module_2 is no longer available.

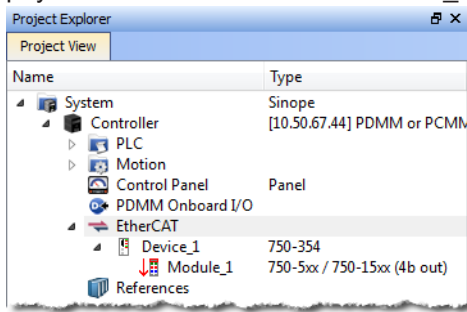

4.4.8 Create a Program

Once the project has been created and the EtherCAT devices have been defined, a program may be created.

TIP

The KAS-IDE programming environment provides language dedicated editors for:

- "Function Block Diagram (FBD) Editor" (→ p. 274)
- "Free Form Ladder Diagram (FFLD) Editor" (→ p. 284)
- "Sequential Function Chart (SFC) Editor" (→ p. 293)
- "Structured Text (ST) / Instruction List (IL) Editor" (→ p. 299)

1. Right-click the Programs item in the project tree and select the language to use.

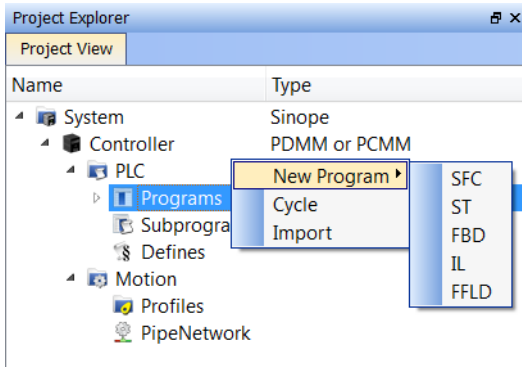

2. Name the program.

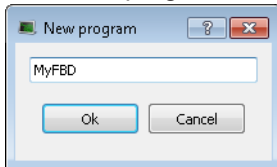

3. Click **Ok** to create the program and open the language-specific editor.

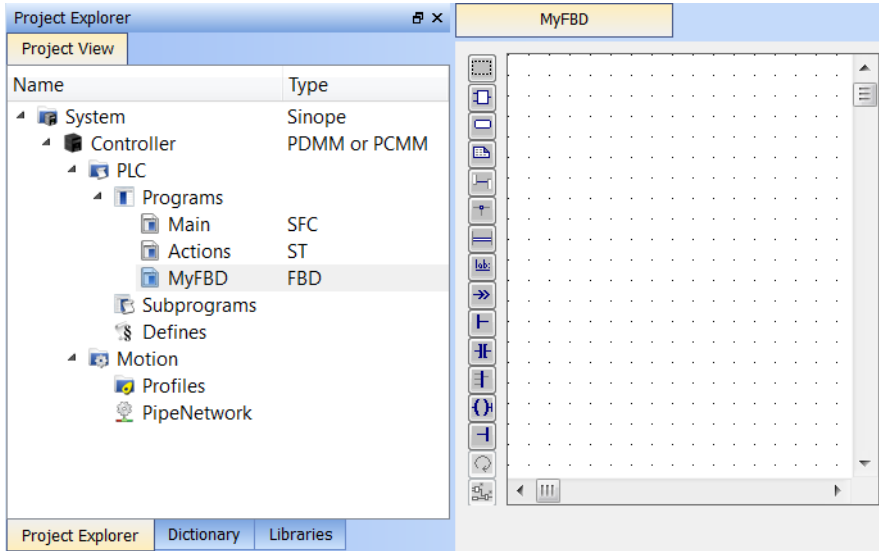

The empty program is ready for you to add functions and function blocks.

Other information you may need to complete your program includes:

- "Create Variables" (→ p. 155)
- "Create and/or Call Functions & Function Blocks" (→ p. 156)

- "Using Constants" (→ p. 157)
- "Map Input and Output to Variables" (→ p. 157)

See "IEC 61131-3 Editors" (→ p. 269) in the "Programs: Structure and Syntax" (→ p. 269) section for more in-depth information on the programming languages.

4.4.8.1 Create Variables

Variables may be created in either of two ways:

- From the "Variables tab" (→ p. 86) of the Dictionary. Clicking **Add Variable** opens the **Create Variable** dialog box.

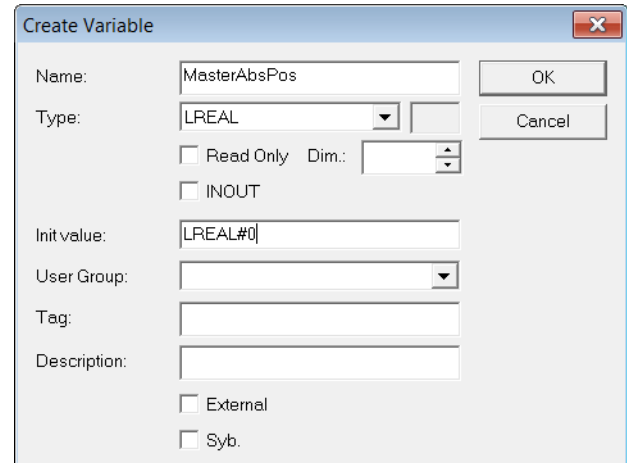
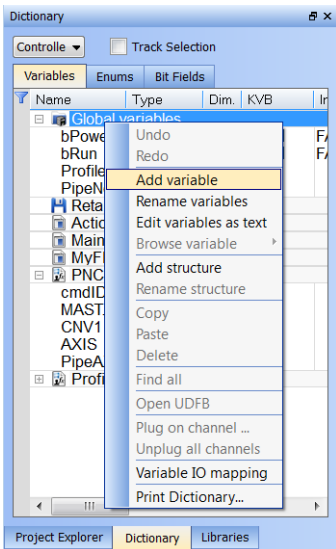

- From the program Editor. Below we see examples of the FBD (click on the Variable button) and FFLD (double-click on the in or out pins of the function) Editors. Enter a name and click OK to open a dialog box that allows you to define the variable.



4.4.8.2 Create and/or Call Functions & Function Blocks

1. Drag an item from the "Libraries" (→ p. 85) into a program

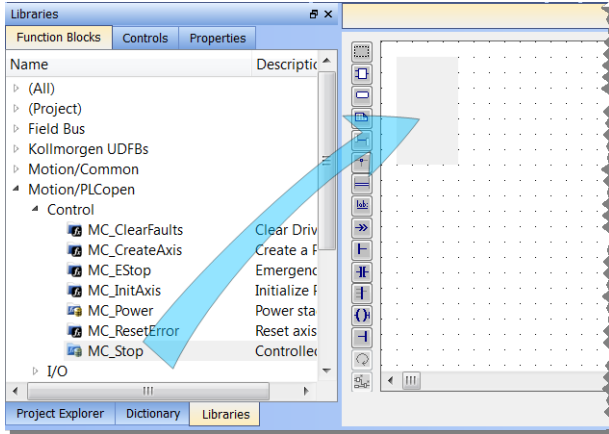

2. Name the new instance of the function or function block

See "Call Functions or Function Blocks" (→ p. 311) for more in-depth information.

To create a function or function block:

1. Declare the function or function block by right-clicking on Subprograms in the Project Tree.

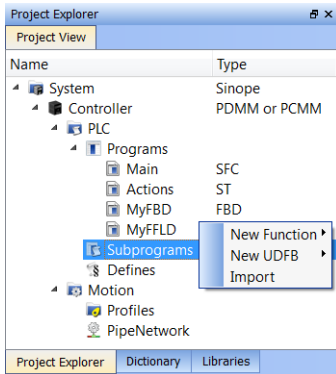

2. Name the function or function block
3. Define the inputs and outputs, and any private variables
4. Call the new function or function block

See Also

- "Create Functions and Function Blocks" (→ p. 308)
- Differences Between Functions and Function Blocks

4.4.8.3 Using Constants

Constants, or Defines, exist at Internal, Global, and a Local level.

Level	Scope
"Internal Defines" (→ p. 312)	All the projects present on your machine.
"Global Defines" (→ p. 313)	All the programs in your project. These are user-defined.
"Local Definitions" (→ p. 313)	Only the current program currently open.

How to define constants

1. Double click on the Defines item in the Project Tree.

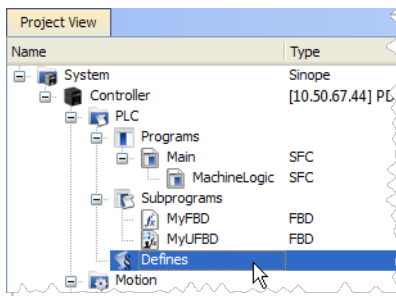

2. Use the text editor to create the defines using this syntax.

```
#define Identifier Equivalence (* comments *)
```

See "Use the Defines List" (→ p. 311).

4.4.8.4 Map Input and Output to Variables

I/O from the EtherCAT motion bus or the controller is easily mapped to PLC variables through the Project Explorer.

The exact process varies slightly depending on the device.

1. Expand the Controller, and EtherCAT nodes in the Project tree.
2. Double-click on the device or I/O slice entry.
3. Map the variables in any of three ways:
 - Drag and drop variables from the Dictionary.
 - Use the "PLC Variable Creation Wizard" (→ p. 317) for Kollmorgen devices.
 - Directly map / unmap the inputs and outputs using the "PLC Variable Selector" (→ p. 318).

See "Map Input and Output to Variables" (→ p. 314).

- To link the newly created Pipe Block, move the arrow to the corresponding Pipe Block with a drag-and-drop operation

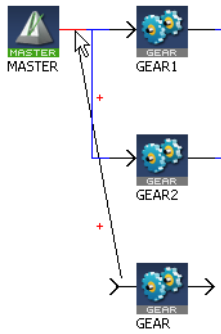

Figure 4-5: Pipe Network - Create a Link

How to delete a Pipe Block?

There are two methods.

- Right-click on the Pipe Block and select the **Delete** command in the contextual menu.
- Select the Pipe Block by clicking on it and then press the **Delete** key.

How to change a Pipe Network link?

- Select the link so that it becomes Red

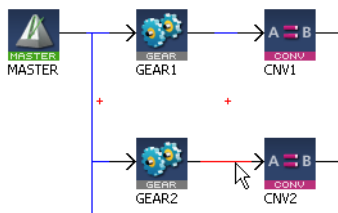

Figure 4-6: Pipe Network - Edit a Link

You can either:

- Right-click and select the **Delete** command if you want to remove the link

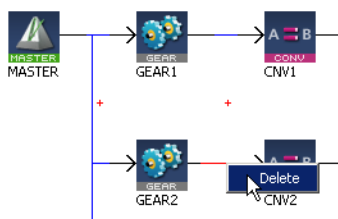

Figure 4-7: Pipe Network - Delete a Link

- Move the arrow to another Pipe Block with a drag-and-drop operation

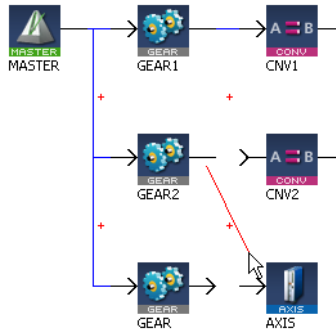

Figure 4-8: Pipe Network - Move a Link

4.4.9.1.2 Edit Properties of Pipe Blocks

Initial values for Pipe Network blocks are entered in the parameter screen for each block. To get to the parameter screen, right-click on a Pipe Block and select the **Properties** command in the contextual menu.

- Right-click on the Pipe Block and select the **Properties** command in the menu

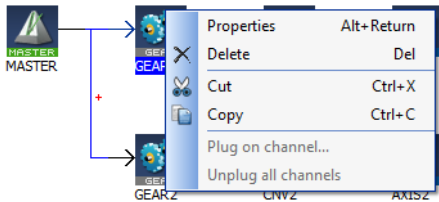

Figure 4-9: Pipe Network - Pipe Block Properties

- The **Properties** window can also be opened by selecting the block and pressing **Alt+Enter**.

You can change the name (or even the type of Pipe Block) in the **General** tab.

The **Parameters** tab gives access to properties related to the type of Pipe Block .

[See example](#)

In this example, the selected name “AngleAdvance” would be used in the PLC application program for this Pipe Network block.

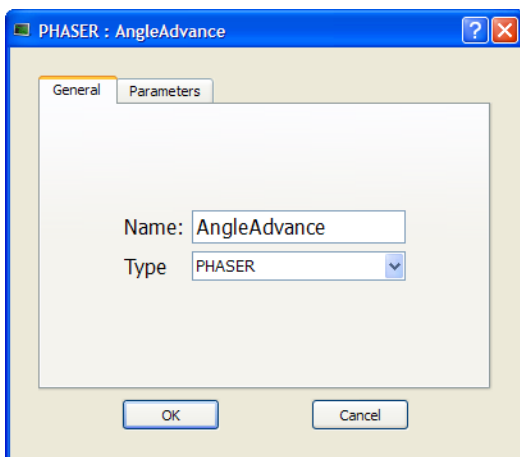

4.4.9.1.3 Map the Axis to the Drive

To link the axis to an EtherCAT drive, you have to do the mapping as described in "Mapped to Axis" (→ p. 324).

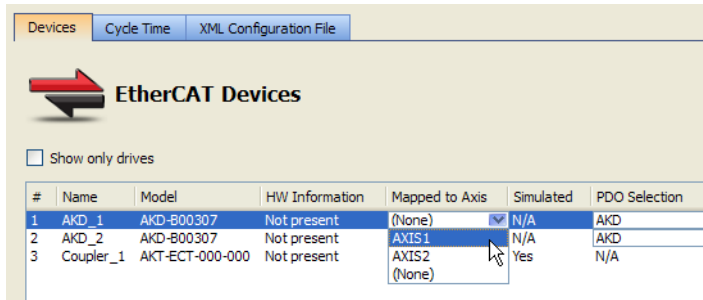

Figure 4-10: Pipe Network - Mapping Axis to Drive

4.4.9.1.4 Add Comments to Pipe Network

To add a comment:

1. Right-click on the Pipe Network editor's background and select the **Add Comment** command in the menu
2. Right-click on the comment opens the contextual menu to let you edit (**Properties** command) or delete the comment

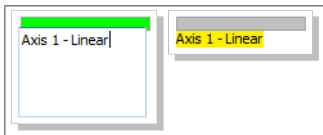

Figure 4-11: Pipe Network comments: editing, and deselected.

Click and drag the gray bar to move the comment.

4.4.9.1.5 Set the Axis Block Position Units

You can set up the position units in the parameter screen of the Axis block.

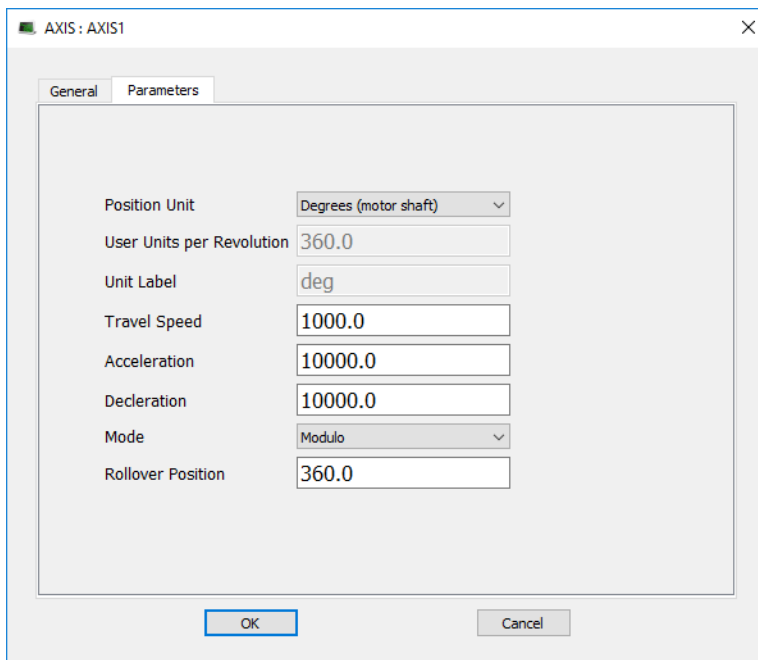

Figure 4-12: Setting Axis Units

Some guidelines for suitable settings are given below:

- The user unit is adapted for the machine
- The user unit should be meaningful for the user
- The same user unit should be used for all related axes, for simplicity

- The user unit should refer to the position of the final moving object, instead of any intermediate part (e.g. the belt position rather than the position of the axis shaft)

Speed is defined in User Units for position / second, e.g. cm/s

Acceleration in User Units for position / second², e.g. cm/s²

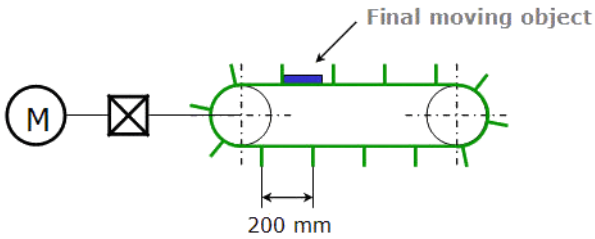

Figure 4-13: Setting the Units - Example

In this example, the belt flaps are about 60 degrees away from each other on the wheel, so 6 flaps would pass on a rotation of the axis. This corresponds to 1200mm/revolution. Because the diagram specifies millimeters, one should select “Custom” from the Position Unit drop down box, enter “1200.0” into the User Units Per Revolution text box, and “mm” box into the Unit label text box.

4.4.9.1.6 Show Pipe Network and Profiles-Generated Code

You can access the code equivalent to the graphical representation with the contextual menu of the Pipe Network item in the Project Explorer as follows:

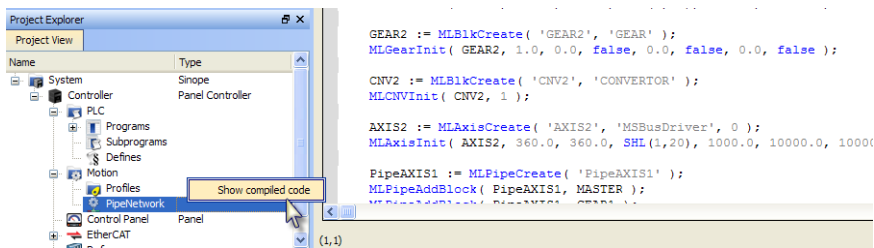

Figure 4-14: Display Source Code of the Pipe Network

The KAS-IDE provides a set of Functions and function blocks for each of the Pipe Blocks. These function blocks allow the logic part of the application to control and interact with the motion engine.

4.4.9.1.7 Pipe Network Functions for the PLC

After creating the Pipe Network, the complete project must be compiled before using the Pipe Network in PLC Programs.

- Compiling creates a list of Functions used in the PLC Program.
- These Functions simplify programming by combining the same function block for all axes in the Pipe Network:

Pipe Network Function	Included Function Blocks (for 2 axis system)
MLPN_ACTIVATE	MLPipeAct(PipeAXIS1); MLPipeAct(PipeAXIS2);
MLPN_CONNECT	MLCNVConnect(CNV1, AXIS1); MLCNVConnect(CNV2, AXIS2);
MLPN_POWER_ON	MLAxisPower(AXIS1); MLAxisPower(AXIS2);

Pipe Network Function	Included Function Blocks (for 2 axis system)
MLPN_POWER_OFF	MLAxisPowerOFF(AXIS1); MLAxisPowerOFF(AXIS2);
MLPN_DEACTIVATE	MLPipeDeact(PipeAXIS1); MLPipeDeact(PipeAXIS2);

See [click here...](#) for more information about constant definitions related to Pipe Network.

TIP

To see how these functions are used, open a project, go to "Project Explorer" (→ p. 71), right-click on **PipeNetwork** and select the **Show compiled Code** command.

4.4.9.1.8 Initialize and Start a Pipe Network

See [Motion State Machine](#)

The Motion State Machine is driven by the IEC 61131-3 application with the help of dedicated function blocks.

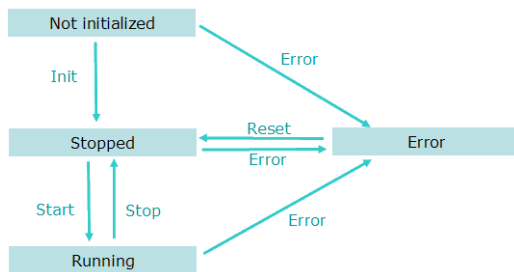
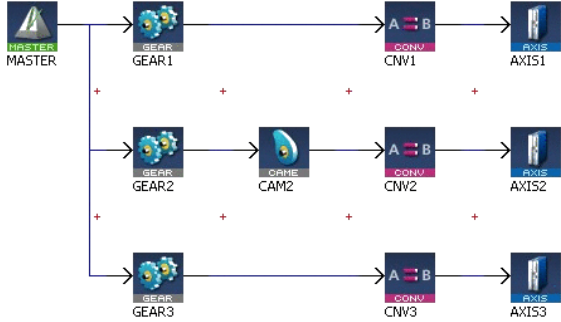

Figure 4-15: Motion State Machine

Each arrow represents a transition from one State to another one.

To start a Pipe Network in an IEC 61131-3 application program, these steps must be performed with their respective functions:

Step	ML Function Block	Description
1. Motion Init	MLMotionInit	<ol style="list-style-type: none"> 1. Initialization of the Motion is done with this dedicated function. 2. Set the Motion engine update rate. 3. Wait for acknowledgment: MLMotionStatus() = MLSTATUS_INITIALISED to continue program operation.
2. Create Cam Profiles	Profiles MLPR_CREATE_PROFILES	Create Cam Profiles from cam files.
3. Create Pipe Network	Pipe Network MLPN_CREATE_OBJECTS	
4. Motion Start	MLMotionStart	<ol style="list-style-type: none"> 1. Starts the motion engine, motion bus driver, and initializes the EtherCAT network to operational mode. 2. Waits for acknowledgment: MLMotionStatus() = MLSTATUS_RUNNING to continue program operation.

Step	ML Function Block	Description
5. Power on all axes	Pipe Network MLPN_POWER_ON	
6. Activate the pipes	Pipe Network MLPN_ACTIVATE	
7. Connect the axes to the pipes	Pipe Network MLPN_CONNECT	<p>Example:</p> <p>In this Pipe Network, the function connects the Converter blocks (CNV1, CNV2 and CNV3) to the Axis blocks:</p> 

4.4.9.1.9 How the Pipe Network interacts with PLC programs

Each Pipe Block is supported by several ML function blocks in the function block Library. As soon as you add a Pipe Block, it is included as well in the Variable Editor.

- Add the FB into your program (see procedure [here](#))
- Select the variable to update

```

First Level  Actions  P1  N  P0  Notes
● ST/IL  ○ FBD  ○ FFLD
Printf('PowerOff', 0, 0, 0, 0);

// Power off all axes
PipeNetwork(MLPN_POWER_OFF);
bLedStatus[1] := FALSE;

// deactivate Pipes
PipeNetwork(MLPN_DEACTIVATE);
MLAxisAbs( ID(*DINT*), Position(*LREAL*) )
    
```

- Press **CTRL+SPACE** to open the [Variable Editor](#)
- Expand the PipeNetwork node and select the name of the Pipe Block in the list (all the Pipe Blocks created in the Pipe Network are listed)

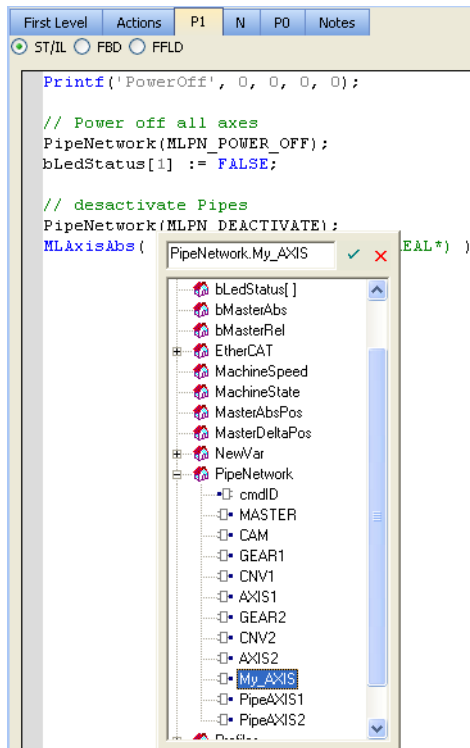

Then your ST instruction is updated

```

// deactivate Pipes
PipeNetwork(MLPN_DEACTIVATE);
MLAxisAbs( PipeNetwork.My_AXIS, Position(*LREAL*) )

```

NOTE

When you add a new Block in the Pipe Network, you first need to compile your project to make the block visible in the list of items.

- Click the  icon to update your code

4.4.9.2 Design Motion with PLCopen Axis

This section describes how to create and modify a PLCopen Axis.

4.4.9.2.1 Create a PLCopen Axis

1. In the Project Explorer, under "PLCopen" (→ p. 78), right-click the "Axes" (→ p. 78) folder and select the **New Axis** command in the menu.
2. Give the new axis a name the Create PLCopen Axis dialog.

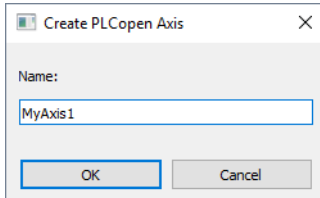

3. Fill in the axis properties by right-clicking on the new axis. See "Modify PLCopen Axis" (→ p. 166) for details.
4. Compile the project to generate the code for the PLCopen axis reference(s).

Each axis will show in the variable type PLCopenCode, which is used by the PLCopen Global variable.

5. The PLCopen.XXXXXX_ref (MyAxis1 in the example below) is an instance of an that can be used in your PLC programs.

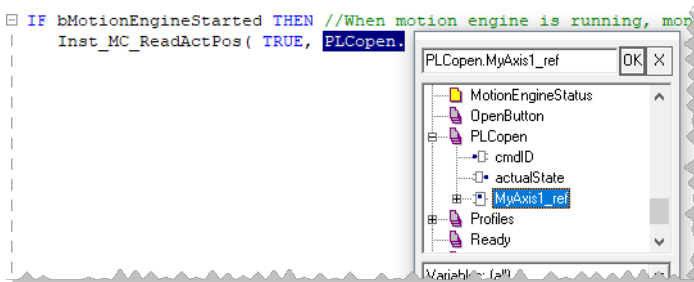

```
IF bMotionEngineStarted THEN //When motion engine is running, mon
Inst_MC_ReadActPos( TRUE, PLCopen.MyAxis1_ref );
```

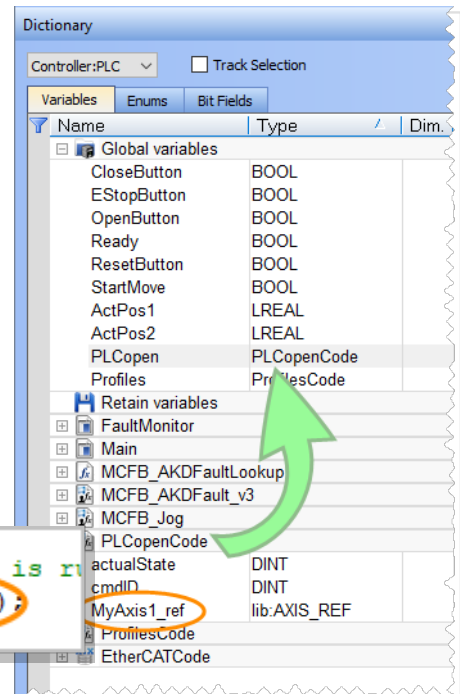

TIP

The PLCopen axis Name and Number in the PLCopen Axis Data dialog, are automatically applied to the PLCopen instance under Global variables in the Dictionary when the project is compiled.

4.4.9.2.2 Modify PLCopen Axis

A PLCopen axis can be modified by using the PLCopen Axis Data dialog.

1. In the "Project Explorer" (→ p. 71), double-click a PLCopen axis.
2. Right-click the PLCopen axis in the project manager and select **Properties** in the menu.

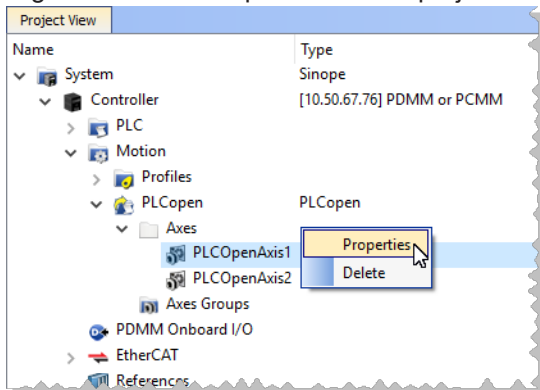

Figure 4-16: PLCopen Axis Context Menu

The PLCopen Axis Data dialog opens:

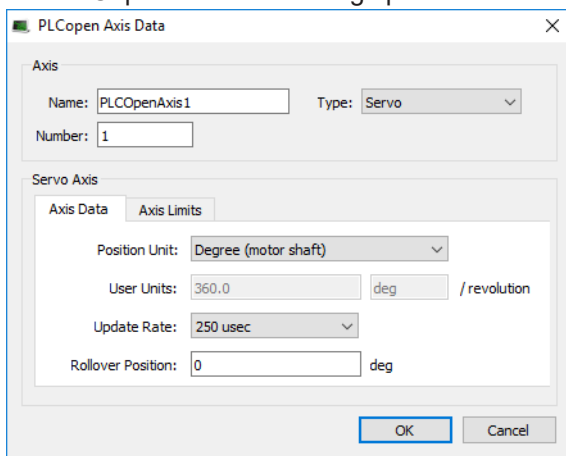
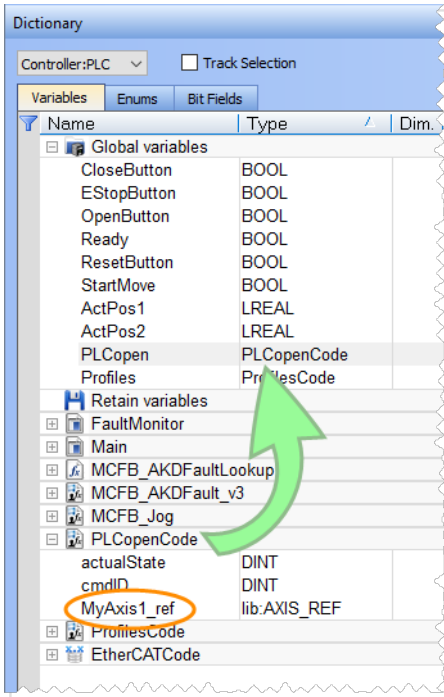

Figure 4-17: PLCopen Axis Data dialog

4.4.9.2.3.1 Axis Name and Number

The PLCopen Axis Name and Number in the PLCopen Axis Data dialog are automatically applied to the PLCopen instance of an AXIS_REF structure under Global variables in the Dictionary when the project is compiled.



The PLCopen.XXXXXX_ref (MyAxis1 in this example) instance can be used in the PLC programs:

```

IF bMotionEngineStarted THEN //When motion engine is running, mon
  Inst_MC_ReadActPos( TRUE, PLCopen.

```

```

    IF bMotionEngineStarted THEN //When motion engine is running, mon
      Inst_MC_ReadActPos( TRUE, PLCopen.MyAxis1_ref );

```

4.4.9.2.4.2 Common Axis Parameters

Three types of axes are available: *Servo/Stepper*, *Digitizing* and *Virtual*. All types have common parameters related to an axis.

The screenshot shows a dialog box titled 'Axis'. It has three input fields: 'Name' with the value 'PLCOpenAxis1', 'Number' with the value '1', and 'Type' which is a dropdown menu. The dropdown menu is currently open, showing three options: 'Servo / Stepper' (highlighted in blue), 'Digitizing', and 'Virtual'.

Figure 4-18: PLCopen Axis Parameters

Parameter	Description
Name	The user-defined name of the axis. The name can consist of 1-16 alphanumeric characters. Spaces are not allowed in the name. The Axis Name identifies the axis displayed in the Project Tree and in the Simulator.
Type	<p>With a <i>Servo/Stepper</i> axis, commands are sent to the axis and feedback is read from the axis. After selecting this option you will need to define the "Axis Data Parameters" (→ p. 172) and "Axis Limits Parameters" (→ p. 173).</p> <p>A <i>Digitizing</i> axis contains position feedback data only, no motion can be commanded. Digitizing axes can use extra or secondary feedback from the Drive or from a third-party EtherCAT feedback device. Selecting a third-party EtherCAT feedback device will require you to enter EtherCAT Bus data (see "Digitizing Axis Parameters" (→ p. 170)) which will vary depending upon your EtherCAT devices. Also see "Create a Digitizing Axis" (→ p. 545) for specifics on different methods.</p> <p>A <i>Virtual</i> axis is an axis with no feedback or drive hardware. The feedback for a virtual axis is automatically generated from the command position. There is no limit to the number of virtual axes that may be used in an application.</p>
Number	The axis number (1-256) specifies the axis for PLCopen motion function blocks.

4.4.9.2.5.3 Digitizing Axis Parameters

When creating a digitizing axis you must set the "Common Axis Parameters" (→ p. 169) (name and number), the EtherCAT Bus parameters, and the "Axis Data Parameters" (→ p. 172). The Digitizing axis type has some additional parameters to define for third-party EtherCAT feedback devices.

Figure 4-19: PLCopen Axis - Bus Parameters

The EtherCAT device parameters are:

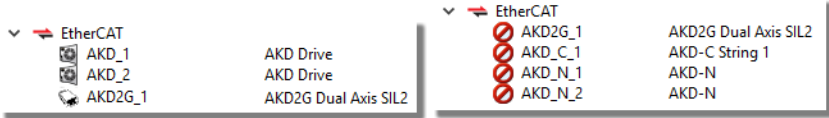
Parameter	Description
Device	<p>Select the device that will provide the digitizing axis feedback. The list is populated by the devices defined in the EtherCAT section of the Project View.</p> 
Address	<p>The digitizing Address is the EtherCAT address of the device in the network. It is the 4-digit node address of the servo drive on the bus. This address is required to assign a digitizing axis to an EtherCAT node that already has a servo axis assignment. The address for the EtherCAT slaves are defined as follows.</p> <ul style="list-style-type: none"> • first device: 1001 • second: 1002 • third: 1003 • etc.
CoE Object	Select the item that will be used to read the feedback.
CoE Object Index	The CoE object index of the feedback device. This is a hexadecimal value.
CoE Object Sub-Index	The sub-index of the feedback device. This is a decimal value.
Encoder Type	Select Singleturn Absolute or Multiturn Absolute .
Single-turn position bit count	Typically 12, 16, 20, or 32-bits. A value of "0" indicates that rollover is not applicable.

NOTE

AKD2G: Digitizing axes mapped to an AKD2G device are particularly easy to work with.

- The PDO 0x1A01 is automatically populated with available feedbacks.

PDO Content

0x1A01 Contents: Size : 8 bytes

Index	Subindex	Object Name	Size [bit]
0x60E4	1	1st additional position act...	32
0x60E4	2	2nd additional position ac...	32

- When a feedback object 0x60E4:1 to 0x60E4:2 is selected, the **Encoder Resolution** is automatically set to 31 bits and the **Feedback Units** field is initialized to the 2³¹ value.
- The **Feedback Units** text box is automatically adjusted to 2(Encoder Resolution) when the **Encoder Resolution** is changed.

- Feedback units will be configured on the AKD2G device based on the resolution specified for the digitizing axis. This is done using init commands during project compilation.

TIP

For more information see "Digitizing Axis - PLCopen Setup" (→ p. 549).

4.4.9.2.6.4 Axis Data Parameters

If a *Servo/Stepper* axis is selected, two tabs are available: Axis Data and Axis Limits. If a Digitizing axis is selected, only the Axis Data tab is available. By default, new axes will be defined using degrees as the measurement unit.

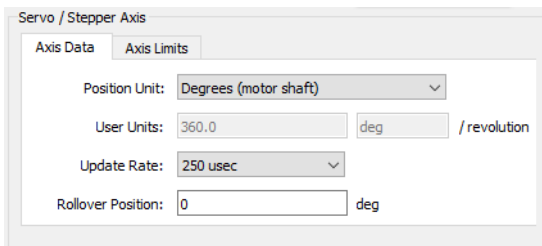

Figure 4-20: Servo/Stepper Axis - Axis Data

The Servo/Stepper Axis - Axis Data parameters are:

Parameter	Description
Position Unit	<p>This field sets the units (see UNIT Parameters) used by the drive axis. When the axis is defined as an AKD2G the controller applies the user units value and label to the drive. These user units will be applied for both Op-mode (running application) and Pre-Op mode (online config) when the EtherCAT network is started up.</p> <ul style="list-style-type: none"> • Counts 16 bit • Degree • Radian • Custom - Selecting Custom allows you to specify the User Units value.
User Units / Revolution	<p>The value used to define an axis position or distance for an axis. The default values are: Counts: 65,536 / revolution Radian: 6.28318530717 (or 2π) / revolution Degree: 360 / revolution When the Unit is set to Custom you may enter your own value and units name, such as <i>gradians, centimeters, or inches.</i></p>

Parameter	Description
Update Rate	<p>The rate at which the axis's feedback is read and a new command position is generated. The choices are:</p> <ul style="list-style-type: none"> • 250 μsec • 500 μsec • 1 msec • 2 msec • 4 msec • 8 msec <p>This rate can be slower or equal to the EtherCAT Cycle Time¹ If you select an axis Update Rate which is faster than the EtherCAT Cycle Time, the axis is set to run at the EtherCAT Cycle Time.</p>
Rollover Position	<p>The value at which the axis position rollovers to zero. Rollover Position is specified in User Units. For example: If the rollover position is 1000, the axis position counts up from 0 to 999 and then rollover back to 0. In the reverse direction, the axis position counts down to 0 and then rollover to 999. If Rollover Position is 0, no rollover occurs. Axis positions become negative values when counting down below 0.</p>

4.4.9.2.7.5 Axis Limits Parameters

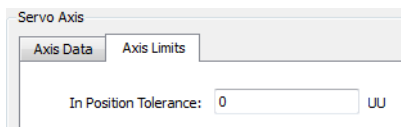

Figure 4-21: Servo Axis - Axis Limits

The Servo Axis - Axis Limits parameters are:

Parameter	Description
In Position Tolerance	The maximum distance between the axis's actual position and its commanded endpoint for the axis to be considered "in position". The In-Position Tolerance is specified in User Units.

1

The EtherCAT Cycle Time specifies the rate at which data is transferred between the control and the drives. The axis Update Rate is the rate at which the PLCopen code reads the feedback, runs its interpolation, and generates a new command position. By allowing some axes to run at a slower rate and staggering the updates on which these axes are interpolated, more axes and/or quicker execution times can be achieved since every axis does not have to be interpolated every update.

4.4.9.2.8 Create PLCopen Axes Groups

If your project utilizes coordinated motion and/or robotic transformations, you need to create one or more Axes Groups in the Project Explorer.

Axes Groups are collections of related axes defined by the data type `AXIS_GROUP_REF`.

- They are typically used by coordinated motion and function blocks such as `MC_SetKinTra`.
- Right-click in this section to create a new Axes Group.
- Groups are populated by dragging an existing axis from the above section into the group.

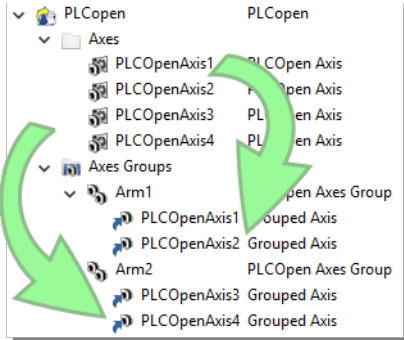

Right-click a group to **Rename** or **Delete** the group.

See Also:

- `MC_KIN_REF` Structure
- `MC_SetKinTra`
- "What are Axes Groups?" (→ p. 521)

4.4.9.2.9 Initialize and Start PLCopen

See Motion State Machine

The Motion State Machine is driven by the IEC 61131-3 application with the help of dedicated function blocks.

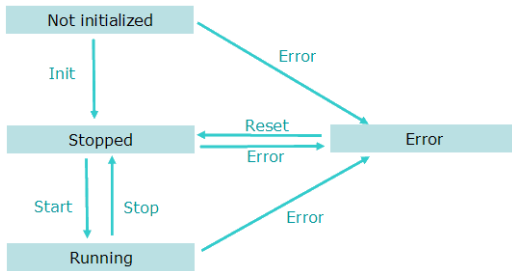

Figure 4-22: Motion State Machine

Each arrow represents a transition from one State to another one.

To start the PLCopen engine in your IEC 61131-3 application program, you have to perform the following steps with their respective functions:

Step	Function Calls	Description
Motion Init	MLMotionInit	Initialization of the Motion is done with this dedicated function Set the Motion engine update rate. Wait for acknowledgement: MLMotionStatus() = MLSTATUS_INITIALISED to continue program operation
Create Cam Profiles	Profiles(MLPR_CREATE_PROFILES);	Create Cam Profiles from cam files
Create/Initialize PLCopen Axes	PLCopen (0);	Create and initialize PLCopen axes from the PLCopenCode attached to the PLCopen node in the Project tree. To view the PLCopenCode, right click on the PLCopen node and select Show Compiled Code .
Motion Start	MLMotionStart	Starts the motion engine, motion bus driver, and initializes EtherCAT network to operational mode, then waits for acknowledgement: MLMotionStatus() = MLSTATUS_RUNNING to continue program operation

4.4.9.3 Design Coordinated Motion

These topics show how to create a coordinated motion application, including adding coordinated motion to existing applications.

- "Blending Between Moves" (→ p. 516)
- "Blending with Transitions" (→ p. 517)
- "Create a Linear or Circular Coordinated Motion Application" (→ p. 518)
- "Differences between MC_GrpHalt and MC_GrpStop" (→ p. 527)
- "Handling Axis Errors" (→ p. 533)
- "Transition Between Moves" (→ p. 535)

See Also

- "Coordinated Motion" (→ p. 514)
- Coordinated Motion Function Blocks

4.4.9.3.1 Create a Linear or Circular Coordinated Motion Application

A Coordinated Motion application can be created in one of these ways:

- Use a Coordinated Motion template to create a new application.
 - Two Coordinated Motion templates are currently available.
 - The first template controls two PLCopen axes in coordinated motion.
 - The second template controls two PLCopen axes in coordinated motion plus a third independent Pipe Network axis.
- Modify an existing application to include coordinated motion functions.
 - When modifying an existing application, axes need to be grouped to define the axes that will be active when performing coordinated motion on that group.
 - See "What are Axes Groups?" (→ p. 521).

NOTE

Coordinated motion can only be performed with PLCopen axes.
 Pipe Network axes do not support this feature.
 Pipe Network axes can be moved independently from coordinated motion groups.
 Any synchronization between coordinated motion and Pipe Network axes must be performed by the PLC application.

4.4.10 Groups

- Related axes are grouped in an axes group.
- Coordinated motion is then performed on an axes group.
- See "What are Axes Groups?" (→ p. 521).

TIP

Remember these vital concepts when making interpolated motion.

- Interpolated motion requires creating a motion group that results in a second group coordinate system.
- Group coordinate system positions are only affected by group motion.
- Non-group coordinate system positions are only affected by non-group motion.

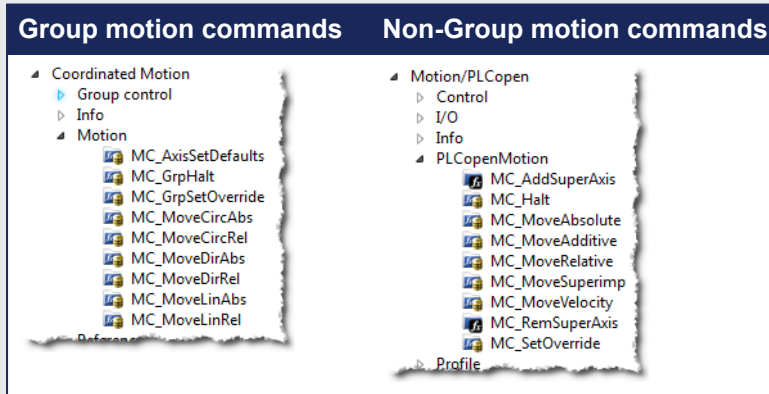

NOTE

Axes that become part of a motion group are first homed using non-group function blocks to establish a home or starting position for the group motion.

4.4.10.0.1.1 Function Block Calls

These function blocks should be called before executing coordinated motion.

1. Call `MLMotionInit (BasePeriod)` to initialize the motion engine.
Base period is specified in microseconds.

```
MLMotionInit(1000.0); // 1000 µSec -> 1 mSec
```

2. Call `MC_CreateAxesGrp (Enable, GroupName, UpdateRate, MaxNumberOfAxes, AxesGroupRef)` to create a Coordinated Motion Axes Group.

NOTE

`MC_CreateAxesGrp` must be called between `MLMotionInit()` and `MLMotionStart()`.

```
Inst_MC_CreateAxesGrp(TRUE, 'GROUP1', 6, 2, Group1_ref);
```

In this example, the axes group name is **GROUP1**, the update rate is 1 mSec (specified by '6') and the maximum number of axes that can be added to the group is 2.

The group reference variable **Group1_ref** is used in future coordinated motion function block calls to reference this newly created group.

3. Call `MC_InitAxesGrp (Enable, AxesGroup, VelLimit, AccLimit, DecLimit, JerkLimit)` to initialize the path limits for velocity, acceleration, deceleration, and jerk.

```
Inst_MC_InitAxesGrp(TRUE, Group1_ref, 100.0, 300.0, 300.0, 1000.0);
```

In this example, the kinematic limits for axes group **Group1_ref** is set.

The velocity limit is set to 100.0 user units/second.

Acceleration and deceleration limits are set to 300.0 User unit/sec².

Jerk is set to 1000.0 User unit/sec³.

4. Call `MC_CreatePLCAxis (AxisName, BusInterface, BusAddress, AxisNumber, AxisType, UserUnits, FeedbackUnits, Rollover, UpdateRate)` to create a Coordinated Motion Axis.
This function must be called for each Coordinated Motion Axis wanted in the application.

NOTE

`MC_CreatePLCAxis` needs to be called between `MLMotionInit()` and `MLMotionStart()`.

```
Inst_MC_CreateAxis(TRUE, 'CoordAxis1', 'EtherCATDriver', 1001, CoordAxis1_AxisNum, 0, 360, 1048576, 0, 6);
Inst_MC_CreateAxis(TRUE, 'CoordAxis2', 'EtherCATDriver', 1002, CoordAxis2_AxisNum, 0, 360, 1048576, 0, 6);
```

In this example:

- Two axes are created and are named **CoordAxis1** and **CoordAxis2**.
- The bus interface for both is **EtherCATDriver**.
- The address of the drive on the bus is 1001 and 1002.
- The axis numbers are set with variables `CoordAxis1_AxisNum` and `CoordAxis2_AxisNum` which is set to an integer value between 1 and 256.
 - Each axis number is unique.
- The axis type for both, 0, indicates a servo axis.
- The user units are 360, which is the user unit portion of the user unit/feedback ratio.
- The feedback units are 1048576.
 - This is the feedback portion of the user unit/feedback ratio.
- The rollover position for both, 0, indicates no rollover.
- The update rate for both, 6, indicates a 1mSec update rate.

5. Call `MLMotionStart ()` to start the Motion and the motion bus driver. This also initializes the EtherCAT network to operational mode.

```
MLMotionStart();
```

6. Call `MC_AddAxisToGrp (Execute, AxesGroup, Axis, IdentInGroup)` for each axis to add to the group.

```
Inst_MC_AddAxisToGrp(TRUE, Group1_ref, CoordAxis1_ref, 0);
Inst_MC_AddAxisToGrp(TRUE, Group1_ref, CoordAxis2_ref, 1);
```

In this example, we are adding two axes, `CoordAxis1` and `CoordAxis2`, to the group referenced by **Group1_ref**.

The axes are stored in the `IdentInGroup` positions 0 and 1.

When the group was created, it was specified that no more than 2 axes will be part of this group.

Therefore, valid `IdentInGroup` locations are 0 and 1.

7. Call `MC_Power (Enable, Axis, EnablePositive, EnableNegative, BufferMode)` for each Coordinated Motion Axis to enable the drive and close the servo loop.

```
Inst_MC_Power1(TRUE, CoordAxis1_ref, TRUE, TRUE, 0);
Inst_MC_Power2(TRUE, CoordAxis2_ref, TRUE, TRUE, 0);
```

In this example, drives `CoordAxis1_ref` and `CoordAxis2_ref` are enabled and the position loop is closed.

8. Call `MC_GrpEnable (Execute, AxesGroup)` to change the state of the Coordinated Motion Axis Group from `GroupDisabled` to `GroupStandby` and allow motion to be performed on the group.

```
Inst_MC_GrpEnable(TRUE, Group1_ref);
```

In this example, **Group1_ref** state is changed from `GroupDisabled` to `GroupStandby`.

The group must be in `GroupStandby` to perform the motion.

9. In these examples, we want to set the current location of the axes in the group to 0, 0. This is done by calling `MC_GrpSetPos (Execute, AxesGroup, Position[], Relative, CoordSystem, BufferMode)`.

```
PosAbs[1] := 0;
PosAbs[2] := 0;
Inst_MC_GrpSetPos(TRUE, Group1_ref, PosAbs, 0, MC_COORDINATE_SYSTEM_ACS, 0);
```

In this example, the axis positions of **Group1_ref** is set to 0, 0.

`PosAbs` specifies the position for each axis in the group.

Relative input, 0, uses `PosAbs` to set the absolute position.

The coordinate system is set to ACS.

NOTE

No motion is performed when this function block is executed.

10. **Optional:** To Add more axes to the group, change the code this way:
 - In Step 2: Update the `MaxNumberOfAxes` input argument so that the group can handle the desired number of axes.
 - In Step 4: Create the additional axes to add to the group.
 - In Step 6: Add the additional axes to the group.

- In Step 7: Power on the additional axes.
- In Step 9: Increase the size of the PosAbs array so it matches the number you used in step 2. Set the position of the additional axes to zero.

After the above function calls have been made, we can start coordinated motion moves.

See Also

- "Perform a Linear Move" (→ p. 525)
- "Perform a Circular Move" (→ p. 521)

4.4.10.0.2.2 What are Axes Groups?

Related axes are grouped in an Axes Group to support interpolation. Axes Groups are accessed using the type `AXES_GROUP_REF`.

This image shows the relationships between the different CSs and groups.

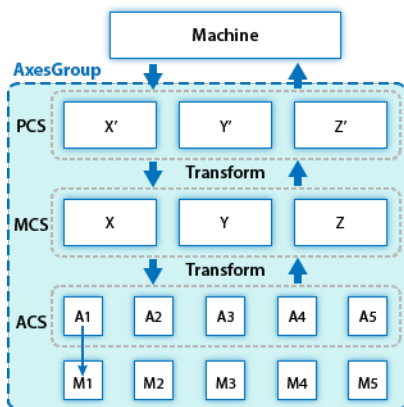

Figure 4-23: Overview of AxesGroup

The Axes Group, shown in blue, provides the interface to the user of the group of axes.

To access the relevant coordinate system, the relevant function blocks have an input Coordinate System which supports the three levels ACS, MCS, and PCS.

Parameters in the AxesGroupRef can include remaining time and remaining distance before target position (or velocity or equal) is reached.

4.4.10.0.3.3 Perform a Circular Move

Circular moves can be programmed using absolute or relative positions using the following function blocks:

- `MC_MoveCircAbs` which commands interpolated circular movement on an axes group to the specified absolute positions.
- `MC_MoveCircRel` which commands interpolated circular movement on an axes group to the specified relative positions.

Prior to performing any coordinated moves, some setup is needed.

- See "Create a Linear or Circular Coordinated Motion Application" (→ p. 518).
- Once these steps have been performed, a circular move can be performed.

In these examples, two circular moves are performed:

- "Absolute Circular Move" (→ p. 179)
- "Relative Circular Move" (→ p. 180)

4.5 Absolute Circular Move

In this move, an absolute circular move goes from (0, 0) to (90, 90).

- CircMode specifies that the aux point (0, 180) is crossed during the paths start to end.
- Call MC_MoveCircAbs.

```

PosCircAuxAbs[0] := 0; // A point on the circle that is crossed on
the
PosCircAuxAbs[1] := 180; // path from start to end point.
PosCircEndAbs[0] := 90; // Absolute end point.
PosCircEndAbs[1] := 90;

Inst_MC_MoveCircAbs(TRUE, Group1_ref, CIRC_MODE_BORDER, PosCircAuxAbs,
PosCircEndAbs, CIRC_PATH_CLKWISE, MaxVel, MaxAcc, MaxDec, 0, CS_ACS, BM_
BUFFERED, TM_NONE, TransParam);

```

In the example, a circular move is performed on axis group **Group1_ref**.

- CircMode is defined as CIRC_MODE_BORDER.
 - This mode indicates that the AuxPoint array input indicates a point on the circle which is crossed on the path from the starting point to the end point.
 - See "Circular Moves Diagrams" (→ p. 523) about CircMode movement options.
- The AuxPoint array, **PosCircAuxAbs**, defines an absolute point on the circle which is crossed on the path from the starting point to the end point.
 - The contents of this array are determined by the CircMode variable CIRC_MODE_BORDER.
- The EndPoint array, **PosCircEndAbs**, contains the absolute end point for each axis in the group.
 - The absolute end point of the axis stored in position 0 (IdentInGroup) of the group is 90.0.
 - The absolute end point of the axis stored in position 1 of the group is 90.0.
- PathChoice is only relevant when CircMode is set to CIRC_MODE_CENTER.
 - In this case, this parameter is not used.
- The maximum velocity is specified by variable **MaxVel** and is specified in User unit/sec.
- The maximum acceleration and deceleration are specified by variables **MaxAcc** and **MaxDec** and are specified in User unit/sec².
- The maximum jerk is not supported and can be set to a value of 0.
- The coordinate system is ACS.
- The BufferMode is set to BM_BUFFERED, indicating the move is buffered.
 - See "Buffer Modes" (→ p. 769) for detailed information.
- The TransitionMode is set to TM_NONE, indicating no transition mode is used.
 - See "Transition Between Moves" (→ p. 535).
- The TransParam array is required.
 - The contents can be set to 0 because the transition mode is not being used.
 - The TransParam array is a 2-element array containing the corner distance and velocity for the transition.

4.6 Relative Circular Move

This is a relative circular move whose end point is (90, 90) from the end of the first move.

- CircMode specifies that the aux point (0, 90) is the relative center of the circle.
- The BufferMode input is set to **Buffered**; this move waits for the first move to complete before it begins executing.
- Call MC_MoveCircRel.

```

PosCircAuxRel[0] := 0; // Relative center of the circle.
PosCircAuxRel[1] := 90;
PosCircEndRel[0] := 90; // Relative end point.
PosCircEndRel[1] := 90; // Start pt 90,90 + rel 90,90 -> 180,180

```

```
absolute end pt
```

```
Inst_MC_MoveCircRel(TRUE, Group1_ref, CIRC_MODE_CENTER, PosCircAuxRel,
PosCircEndRel, CIRC_PATH_CLKWISE, MaxVel, MaxAcc, MaxDec, 0, CS_ACS, BM_
BUFFERED, TM_NONE, TransParam);
```

In the example, all the variables have the same meaning as the circular absolute example except:

- CircMode is defined as CIRC_MODE_CENTER.
 - This mode indicates that the AuxPoint array input indicates the center point of the circle.
 - See "Circular Moves Diagrams" (→ p. 523) about CircMode movement options.
- The AuxPoint array, **PosCircAuxRel**, defines the relative center point of the circle.
 - The contents of this array are determined by the CircMode variable, CIRC_MODE_CENTER.
- The EndPoint array, **PosCircEndRel**, contains the relative end point for each axis in the group.
 - The relative end point of the axis stored in position 0 (IdentInGroup) of the group is 90.0.
 - The relative end point of the axis stored in position 1 of the group will be 90.0.
- PathChoice is relevant when CircMode is set to CIRC_MODE_CENTER.
 - In this case, PathChoice is CIRC_PATH_CLKWISE which specifies the direction of the path.

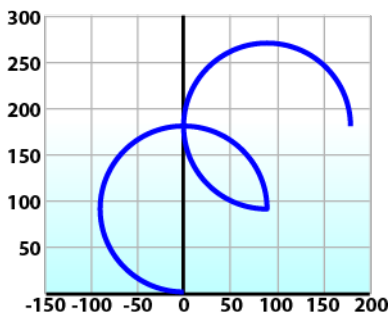

4.6.0.0.1.1 Perform a Linear Move

Linear moves can be programmed using absolute or relative positions using these function blocks:

- MC_MoveLinAbs commands interpolated linear movement on an axes group to the specified absolute positions.
- MC_MoveLinRel commands interpolated linear movement on an axes group to the specified relative positions.

Prior to performing any coordinated moves, some setup is needed.

- See Create a Linear or Circular Coordinated Motion Application.
- Once these steps have been performed, a linear move can be performed.

In these examples, two linear moves are performed.

- "Absolute Linear Move" (→ p. 181)
- "Relative Linear Move" (→ p. 182)
- "Linear Move With More Than Two Axes" (→ p. 183)

4.7 Absolute Linear Move

In this move, an absolute linear move goes from (0, 0) to (100, 200).

- Call MC_MoveLinAbs.
 - PositionArray is an array of absolute end positions containing one position for each axis in the group.
 - The input velocity, acceleration, deceleration, and jerk establish the maximum values for the move.

```

PosArrayAbs[0] := 100;
PosArrayAbs[1] := 200;
TransParam[0] := 0;

Inst_MC_MoveLinRel(TRUE, Group1_ref, PosArrayAbs, MaxVel, MaxAcc,
MaxDec, 0, CS_ACS, BM_BUFFERED, TM_NONE, TransParam);

```

In the example, a linear move is performed on axis group **Group1_ref**.

- PosArrayAbs contains the absolute end points of the axes in the group.
 - The axis stored in position 0 (IdentInGroup) of the group is moved to 100.0.
 - The axis stored in position 1 of the group is moved to 200.0.
- The maximum velocity is specified by variable **MaxVel** and is specified in User unit/sec.
- The maximum acceleration and deceleration are specified by variables **MaxAcc** and **MaxDec** and are specified in User unit/sec².
- The coordinate system is ACS.
- The BufferMode is set to BM_BUFFERED, indicating the move is buffered.
 - See "Buffer Modes" (→ p. 769) for detailed information.
- The TransitionMode is set to TM_NONE, indicating no transition mode is used.
 - See "Transition Between Moves" (→ p. 535).
- The TransParam array is required.
 - The contents can be set to 0 because the transition mode is not being used.
 - There has to be one array entry for each axis in the group.

4.8 Relative Linear Move

In this move, a relative linear move goes a distance of (-75, 50) from the end of the first move.

- Call MC_MoveLinRel.
- The Distance input is an array of distances, one distance for each axis in the group.
- The input velocity, acceleration, deceleration, and jerk establish the maximum values for the move.

```

DistArrayRel[0] := -75.0; // Start pt 100 - rel 75 -> 25 absolute end
pt
DistArrayRel[1] := 50.0; // Start pt 200 + rel 50 -> 250 absolute end
pt
TransParam[0] := 0;

Inst_MC_MoveLinRel(TRUE, Group1_ref, DistArrayRel, MaxVel, MaxAcc,
MaxDec, 0, CS_ACS, BM_BUFFERED, TM_NONE, TransParam);

```

In the example, all the variables have the same meaning as the absolute linear example except DistArrayRel.

- DistArrayRel contains the relative distance to move for each axis in the group.
- The axis stored in position 0 (IdentInGroup) of the group is moved a distance of -75.0.
- The axis stored in position 1 of the group is moved a distance of 50.0.

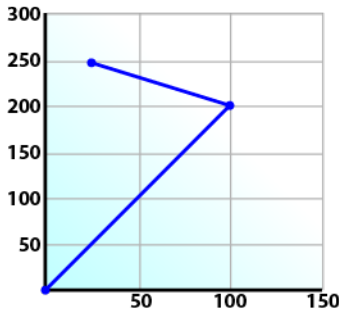

4.9 Linear Move With More Than Two Axes

NOTE

The dimensionality of the move is determined by the number of axes mapped to the group. This implies that a group which could hold a maximum of three or more axes does two dimensional moves if it only has two valid axes mapped to it.

To perform higher dimensional moves, additional axes must be added to the group.

The procedure for this are in Create a Linear or Circular Coordinated Motion Application.

After the additional axes are added, perform these steps.

1. From the Dictionary, update the array size of the variable being passed (PosArrayAbs and DistArrayRel in the "Absolute Linear Move" (→ p. 181) and "Relative Linear Move" (→ p. 182) examples) to the Position input so its length matches the maximum number of axes allowed in the group.
2. Set the desired values for the additional axes in the now larger position arrays.

4.9.0.0.1.1 Circular Moves Diagrams

4.10 CircMode = BORDER

- The user defines the end point and a border point (= input AuxPoint) on the sector of the circle which the machine will traverse.
- For Relative mode, both points are defined relative to the starting point.
- Advantage
 - The border point can usually be reached by the machine, i.e., it can be taught.
- Disadvantage
 - Restricted to angles < 360° in one single command.



1. Starting point.
2. Border point.
3. End point.

4.11 CircMode = CENTER

- The user defines the end point and center point (= input AuxPoint) of the circle.
- The input PathChoice defines clockwise or counter-clockwise motion.
- For Relative mode, both points are defined relative to the starting point.
- Advantage
 - Full 360° moves are possible.
- Disadvantages
 - Cannot perform zero-distance moves.
 - Over-determination of the circle equation.



1. Starting point.
2. Center point.
3. End point.
4. Clockwise move.
5. Counter-clockwise move.

A 360° move is performed if the end point is the same as the start point.



1. Starting and Ending point.
2. Center point.
3. Clockwise move.
4. Counter-clockwise move.

4.11.1 Add an HMI Device

To control your application, HMI panels can be downloaded to a dedicated [HMI](#) device.

It can also be embedded into targeted "Controllers" (→ p. 685).

- Modbus TCP is used for communication from an HMI panel's Ethernet port to the X32 connector on the top of a AKD PDMM or PCMM.
- Modbus communication may be active while programming the controller through the KAS-IDE while the AKD PDMM or PCMM is connected to a network, switch, or hub.
- The KAS-IDE is automatically linked to the KVB HMI development software, and the Modbus addresses are automatically set.
- See [KDN](#) for more information.

When running the KAS Simulator, an internal HMI editor is also available to debug the application.

See "Design the HMI with the Internal Editor" (→ p. 464) for more information.

4.11.1.1 Create a KVB Project

KVB projects are managed in the Project Explorer.

Use this procedure to create a project:

1. In the Project Explorer, right-click on the **System** item to open the contextual menu.
2. Select the **Add HMI device** command.
3. Select the device name within the list and click **OK**.

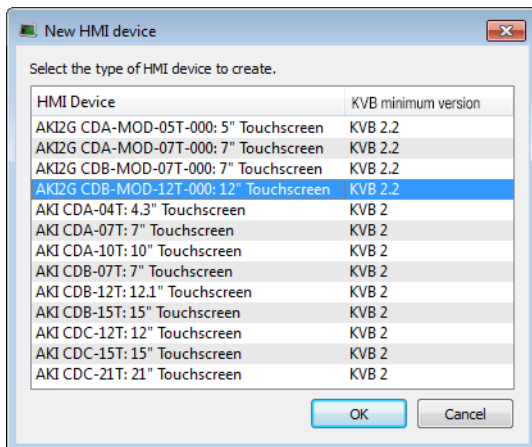

Figure 4-24: Select an AKI to add.

TIP

The content varies depending the version of KVB installed on your system.

If you have KVB 1.1 installed you may open projects that have a KVB 2.1 panel but you cannot open the panel in KVB.

4. Right-click on the newly created item and select the **Rename** command to change its name.
5. Right-click and select the **Add KVB Project** command.

NOTE

This command is disabled when a KVB panel is already created for the current HMI device.

4.11.1.2 Map Variables to HMI

For HMI, the variable mapping is done in two phases.

- Phase 1 - Tag all of the variables to be exported from the HMI project (see procedure below).
- Phase 2 - Use this mapping file when [designing the HMI](#)

The tag operation directly takes place in the Dictionary:

1. Open the Variable list editor available in the [Dictionary](#) toolbox

✎ TIP

Double-click the Dictionary header to view the widget as a popup window.

2. In the KVB column, select the variables to map.

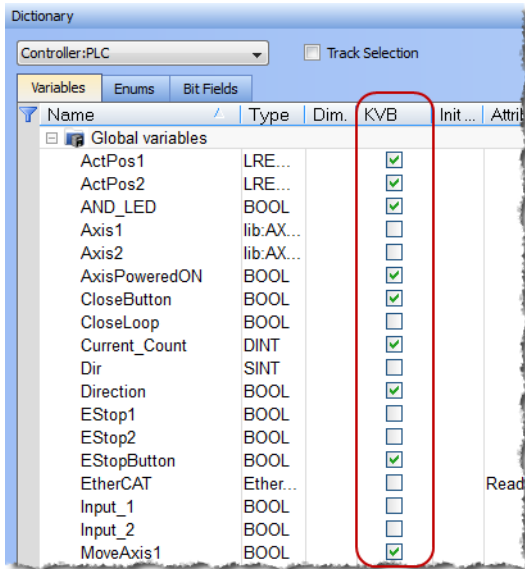

Figure 4-25: Variable Mapping to KVB.

✎ TIP

Selecting the variable alone does not guarantee it is exported.
The POU must also be set to compile.
See "Ensuring Variables are Exported" (→ p. 220).

ⓘ IMPORTANT

Based on Modbus, the communication is limited to 32-bits.
As a consequence:

- Data type conversion can lead to a loss in accuracy:
 - LREAL variables are saved as REAL.
 - LINT variables are converted to DINT.
 - ULINT variables are saved as UDINT.
- LWORD data types cannot be used in the HMI when using KVB.
 - This is because variables of this type are not exported, even when selected.
- STRING variable data types are allowed in the HMI when using KVB 2.0 or later
 - They are not supported in KVB 1.2.
 - STRING variables allow a maximum of 240 characters.
 - STRING variables whose size exceed the maximum string length of 240 characters generate a warning message in the Compiler Output window when being exported over Modbus.
 - Only the first 240 characters are exported.

- See "Compiler Output tab" (→ p. 115).

```

Information and Logs
*Local log*  Controller log  Find and Replace  Browse Variable  Breakpoints  Compiler Output
Compile Project
Controller:..... Compile Device .....
Controller:..... Generating Modbus configuration from the dictionary KVB check boxes .....
Controller:KVB: Warning : (Global):Sample_Inst is having a member NewVar (String variable) length is more than supported Modbus string length of 240!
Controller:KVB: Warning : (Global):Sample_Inst contains variables which are not supported by KVB
Controller:KVB: Warning : (Global):Inst_NewStructure1 is having a member Inst_NewStructure.NewVar (String variable) length is more than supported Modbus string length of 240!
Controller:KVB: Warning : (Global):Inst_NewStructure1 contains variables which are not supported by KVB
Controller:KVB: Warning : UntitledST:Inst_NewStructure is having a member NewVar (String variable) length is more than supported Modbus string length of 240!
Controller:..... Generating Modbus Files successful .....
Controller:..... Compile PLC .....
Controller:PLC:Compiler V13.5.10.0
Controller:PLC:>> Complex variables stored in a separate segment
Controller:PLC>Loading application symbols...

```

- Variables of types PNCode, ProfilesCode, or instances of UDFB cannot be used in the HMI.

TIP

Non-primitive data types which are not exported over Modbus generate a warning message in the Compiler Output window.

See "Compiler Output tab" (→ p. 115).

3. Compile the application to create the Modbus mapping file.

NOTE

- If the set of tagged variables is changed in the dictionary, the text file must be updated by recompiling the project.
- The Modbus variables defined in KAS-IDE are imported into Kollmorgen Visualization Builder only when KVB is started.
There is no update in real-time between the two applications.

4. Open the **KVBProject** from the Project Tree.
This automatically transfers the tagged variables.

4.11.1.2.1.1 Variables to Export

These types of variables can be exported to the HMI:

- The fundamental data types: BOOL, BYTE, DINT, DWORD, INT, LREAL, REAL, SINT, STRING, TIME, UDINT, UINT, USINT, WORD
- Arrays of supported data types
- Structures that include members of supported data types

4.11.1.2.2.2 Structures to Export

- Arrays of BOOLS such as a structure that includes a BOOL array member and instances of UDFB members.
- An array of structures that include INT and LREAL members
- A structure that includes both instances of UDFB member as well as an embedded structure which includes an INT member and instances of a UDFB member.
 - This is because the embedded structure has an INT member and the outer structure can be exported too.

4.11.1.2.3.3 Structure that Cannot be Exported

A structure that includes instances of UDFB or LWORD members only.

4.11.1.3 Design KVB Panel with Kollmorgen Visualization Builder

- Double-click the new KVB panel to open the builder (for more details, refer to "Using Kollmorgen Visualization Builder" (→ p. 458).)

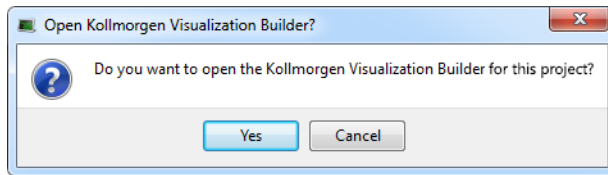

Figure 4-26: Open the Kollmorgen Visualization Builder Builder

ⓘ IMPORTANT

You must have the specific application already installed on your machine.

👉 TIP

Be sure to close the Kollmorgen Visualization Builder before deleting the KVB Panel from the IDE.

4.11.2 SafePLC2 Projects

A node can be added to the Project tree connected to a [SafePLC2](#) project.

- This is used to synchronize a SafePLC2 project with a KAS project.
- The KAS-IDE automatically generates the PDOs for the connected devices and establishes the Black Channel with the EtherCAT Safety network.

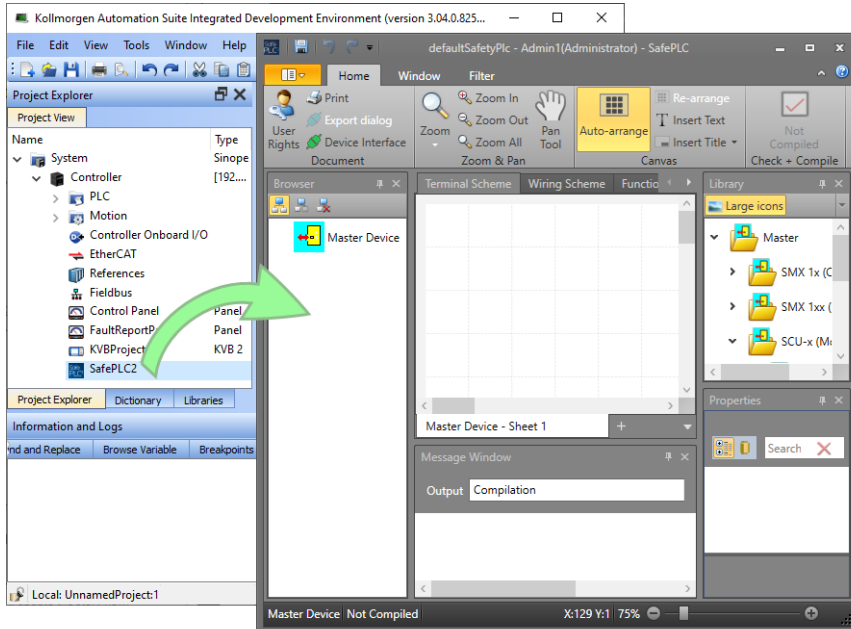

See the online help or the AKT2G I/O Manual for more information.

4.11.3 Overview: Compile, Connect, Download, and Run

The last part of building a project is to compile the code, connect to the controller, download, and then run the application.



1. "Set the Compilation Options" (→ p. 222)
2. "Compile the Project" (→ p. 225)
3. "Connect to the Controller" (→ p. 226)
4. "Download the Project" (→ p. 228)
5. "Start / Stop the Device" (→ p. 230)

4.11.4 Create Project - Advanced

This section provides reference for setting up hardware, performing tasks which may not apply to every user, and other more advanced topics.

4.11.5 Add and Configure a Servo Drive

4.11.5.1 Add the Drive

1. In the Project Explorer, right-click the **EtherCAT** node to open the menu
2. Select the **Add Kollmorgen Device** command
(this option is only enabled when you are **not** connected to the controller)
3. Select the specific device to add.

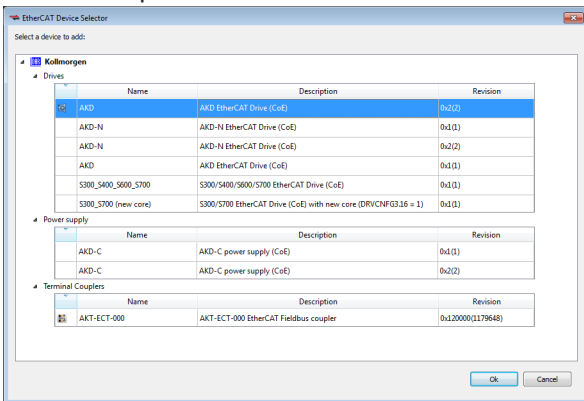

NOTE

When choosing an AKD be sure to select the newest revision. Older revisions may show in the list of options, but they may not be feature complete. If one of these drives is selected, only the **General Properties** tab is available.

4. Click **Ok** when you are done (for more details about the AKD drive GUI, click [here](#))

- In the Project Explorer, right-click the device node and select the **Rename** command

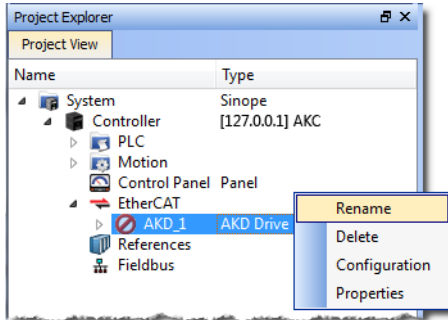

- Define the name for the new device
Note that the name is limited to 10 characters and can only include letters, numbers, and underscores.

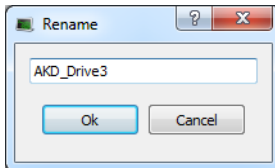

- Click **OK**

TIP

An alternative method to add a drive is to rely on the [auto scan](#) feature.

When an AKD drive is added to the project tree, it must be mapped to a physical drive. This step is explained in "Add and Configure Third Party Devices" (→ p. 204).

4.11.5.2 Configure the AKD / AKD2G Drive

The Configuration tab under the EtherCAT: AKD tab is used to configure drives once these conditions have been met:

- The "EtherCAT Scan and Association" (→ p. 138) has been performed.
- Your project is compliant with the physical devices on the EtherCAT network.
- You have activated the [Online Configuration](#) mode in the "EtherCAT Toolbar" (→ p. 255).

You then have access to all of the AKD configurations and parameters.

- In the Project Explorer, double-click the new AKD Drive or select Configuration from the context menu to open all the parameters linked to it.

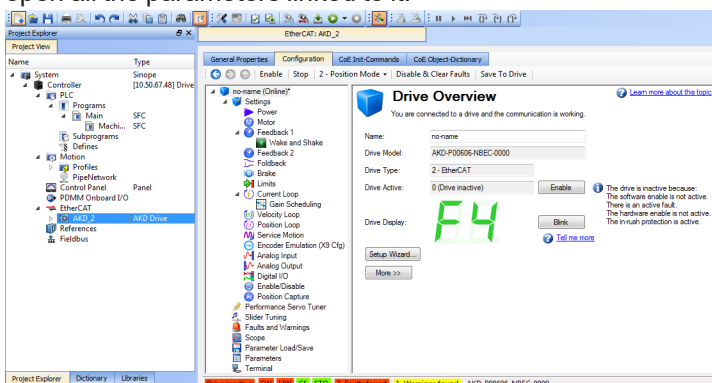
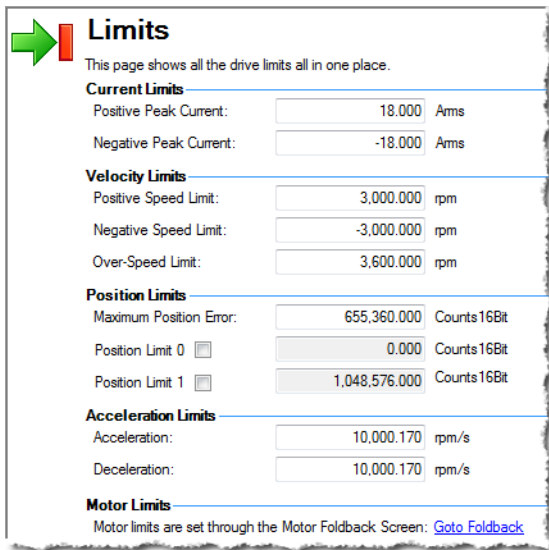
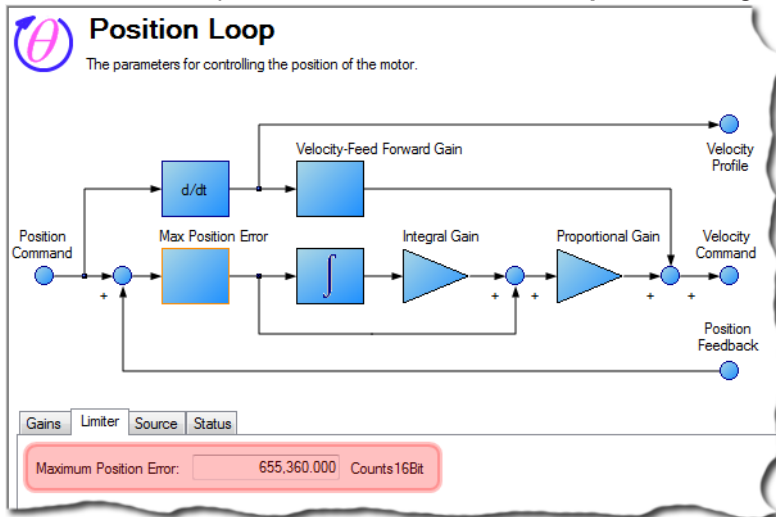

Figure 4-27: AKD Configuration

- Define the motion parameters in the **Limits** tab to configure the limited motor torque, speed, and acceleration



- Define the motion parameters in the **Position Loop** tab to configure the limiting error.



- Define the resolution of the feedback position in the **Feedback** tab. For all feedback types, the motor position feedback sent from the AKD drive to the controller through EtherCAT is normalized to 20 bits/rev or 1048576 counts/rev.
- Define the units used for the motion ¹:
 - For Pipe Network, see "Set the Axis Block Position Units" (→ p. 161).
 - For PLCopen, see "Axis Data Parameters" (→ p. 172).

NOTE

User units in the PLC language editors are:

- Position: User unit
- Velocity User unit/sec
- Acceleration: User unit/sec²

Several AKD tabs contain units that follow the standard AKD format:

- Position: 16 bits/rev
- Velocity: RPM
- Acceleration: RPM/ Sec

¹The normal units screen in the AKD WorkBench GUI is not included in the KAS-IDE.

6. To ensure high performance, define the load for your servo system.

KAS-IDE provides several options for performing the drive tuning:

- Slider Tuning - Use the slider to adjust to a designated bandwidth (pre-calculated tuning).
- Performance Servo Tuner - Takes the drive through an automatic tuning sequence.
- Manual Tuning - Used to set gains individually for:
 - Current Loop
 - Position Loop
 - Velocity Loop
- See "AKD Drive Configuration" (→ p. 817) for more information about AKD configuration.
- See the "FAQs" (→ p. 823) for more information about AKD Firmware Download.

NOTE

After your application is downloaded to the controller, you can activate the "Online Configuration Mode" (→ p. 255) to configure the drives with the **Setup Wizard**.

See "AKD Setup Wizard" (→ p. 193) for more information.

4.11.5.3 Save Parameters to Non-Volatile Memory

The AKD parameters can be saved to non volatile memory in the drive. For more details, refer to "Save parameters to NV memory" (→ p. 325)

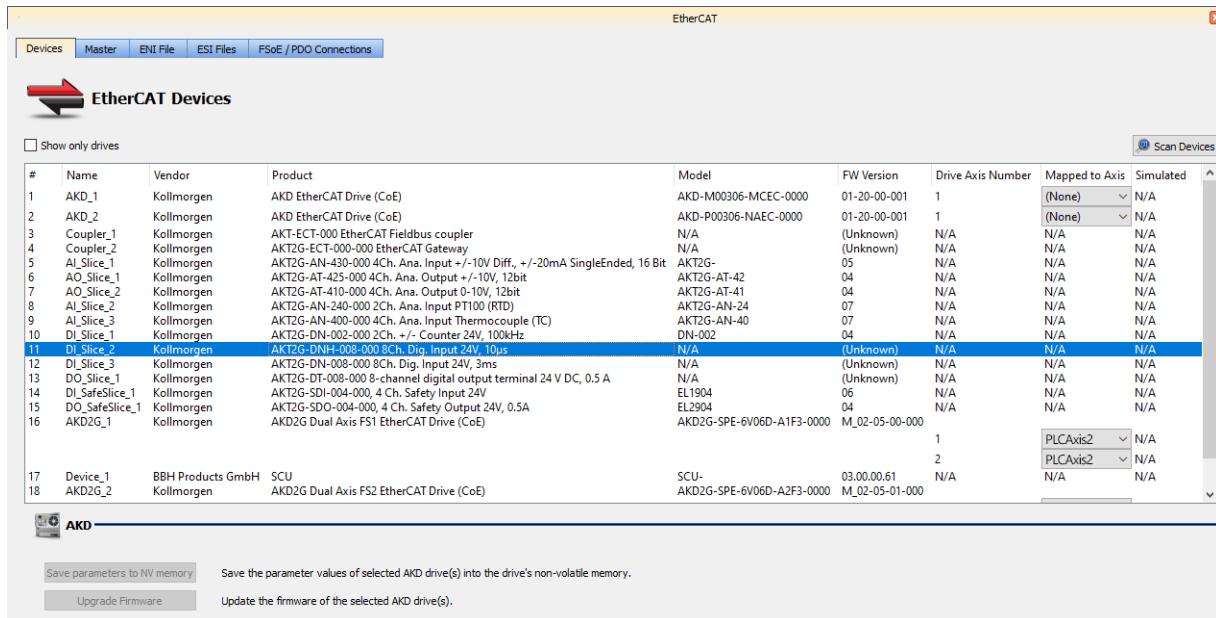

The screenshot shows the "EtherCAT" configuration window with a tab for "Devices". Below the tab is a table of detected devices. The table has columns for #, Name, Vendor, Product, Model, FW Version, Drive Axis Number, Mapped to Axis, and Simulated. Row 11 is highlighted in blue.

#	Name	Vendor	Product	Model	FW Version	Drive Axis Number	Mapped to Axis	Simulated
1	AKD_1	Kollmorgen	AKD EtherCAT Drive (CoE)	AKD-M00306-MCEC-0000	01-20-00-001	1	(None)	N/A
2	AKD_2	Kollmorgen	AKD EtherCAT Drive (CoE)	AKD-P00306-NAEC-0000	01-20-00-001	1	(None)	N/A
3	Coupler_1	Kollmorgen	AKT-ECT-000 EtherCAT Fieldbus coupler	N/A	(Unknown)	N/A	N/A	N/A
4	Coupler_2	Kollmorgen	AKT2G-ECT-000-000 EtherCAT Gateway	N/A	(Unknown)	N/A	N/A	N/A
5	AI_Slice_1	Kollmorgen	AKT2G-AN-420-000 4Ch. Ana. Input +/-10V Diff. +/-20mA SingleEnded, 16 Bit	AKT2G-	05	N/A	N/A	N/A
6	AO_Slice_1	Kollmorgen	AKT2G-AT-425-000 4Ch. Ana. Output +/-10V, 12bit	AKT2G-AT-42	04	N/A	N/A	N/A
7	AO_Slice_2	Kollmorgen	AKT2G-AT-410-000 4Ch. Ana. Output 0-10V, 12bit	AKT2G-AT-41	04	N/A	N/A	N/A
8	AI_Slice_2	Kollmorgen	AKT2G-AN-240-000 2Ch. Ana. Input PT100 (RTD)	AKT2G-AN-24	07	N/A	N/A	N/A
9	AI_Slice_3	Kollmorgen	AKT2G-AN-400-000 4Ch. Ana. Input Thermocouple (TC)	AKT2G-AN-40	07	N/A	N/A	N/A
10	DI_Slice_1	Kollmorgen	AKT2G-DN-002-000 2Ch. +/- Counter 24V, 100kHz	DN-002	04	N/A	N/A	N/A
11	DI_Slice_2	Kollmorgen	AKT2G-DNH-008-000 8Ch. Dig. Input 24V, 10µs	N/A	(Unknown)	N/A	N/A	N/A
12	DI_Slice_3	Kollmorgen	AKT2G-DN-008-000 8Ch. Dig. Input 24V, 3ms	N/A	(Unknown)	N/A	N/A	N/A
13	DO_Slice_1	Kollmorgen	AKT2G-DI-008-000 8-channel digital output terminal 24 V DC, 0.5 A	N/A	(Unknown)	N/A	N/A	N/A
14	DI_SafeSlice_1	Kollmorgen	AKT2G-SDI-004-000, 4 Ch. Safety Input 24V	EL1904	06	N/A	N/A	N/A
15	DO_SafeSlice_1	Kollmorgen	AKT2G-SDO-004-000, 4 Ch. Safety Output 24V, 0.5A	EL2904	04	N/A	N/A	N/A
16	AKD2G_1	Kollmorgen	AKD2G Dual Axis FS1 EtherCAT Drive (CoE)	AKD2G-SPE-6V06D-A1F3-0000	M_02-05-00-000	1	PLCAxis2	N/A
17	Device_1	BBH Products GmbH	SCU	SCU-	03.00.00.61	N/A	N/A	N/A
18	AKD2G_2	Kollmorgen	AKD2G Dual Axis FS2 EtherCAT Drive (CoE)	AKD2G-SPE-6V06D-A2F3-0000	M_02-05-01-000	2	PLCAxis2	N/A

Below the table, there are two buttons: "Save parameters to NV memory" and "Upgrade Firmware".

4.11.5.4 AKD Setup Wizard

The wizard is used to configure drives once these conditions have been met:

- The "EtherCAT Scan and Association" (→ p. 138) has been performed.
- Your project is compliant with the physical devices on the EtherCAT network.
- You have activated the [Online Configuration](#) mode in the "EtherCAT Toolbar" (→ p. 255).

You then have access to the AKD parameters that are used when the drive is running.

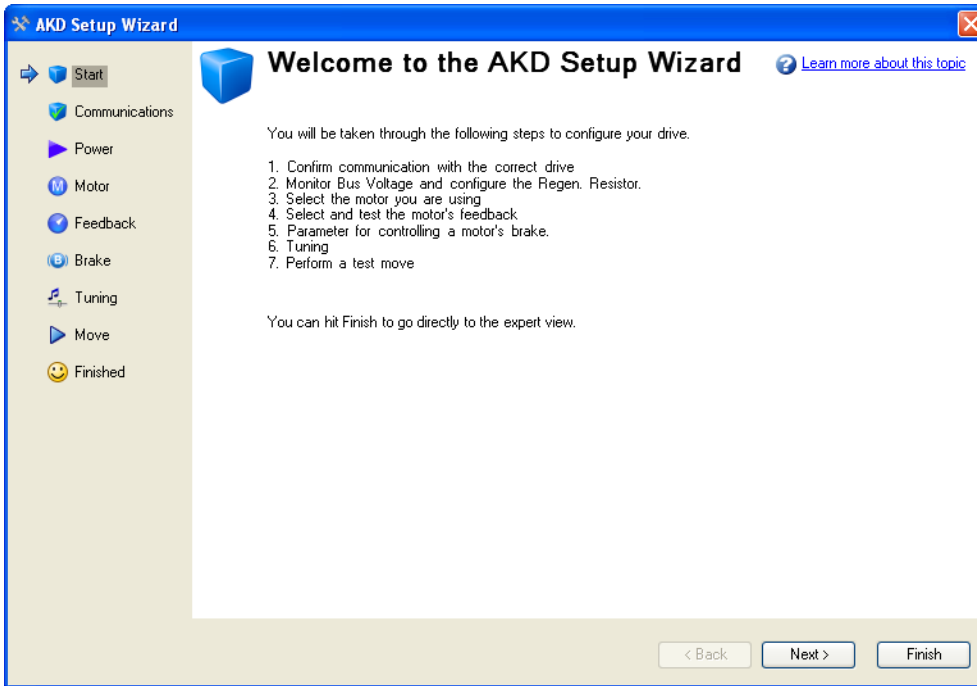

Figure 4-28: AKD Setup Wizard

4.11.5.5 Configure Onboard I/O

The procedure to define the local I/Os of the AKD drive is very similar to the one for I/O slices, with these exceptions:

- Channel column also contains in brackets the connector and pin number.
- PLC variable selection applies to digital inputs and analog inputs and outputs.
 - See "Map I/O from the Project Explorer" (→ p. 337) for more information.

4.11.5.6 Digital Input Mode

NOTE

The way to set the Digital Input mode on an AKD drive has changed with KAS 2.6. Previously, this setting was done in the Onboard I/O view (seen below) where the IO was mapped to PLC variables.

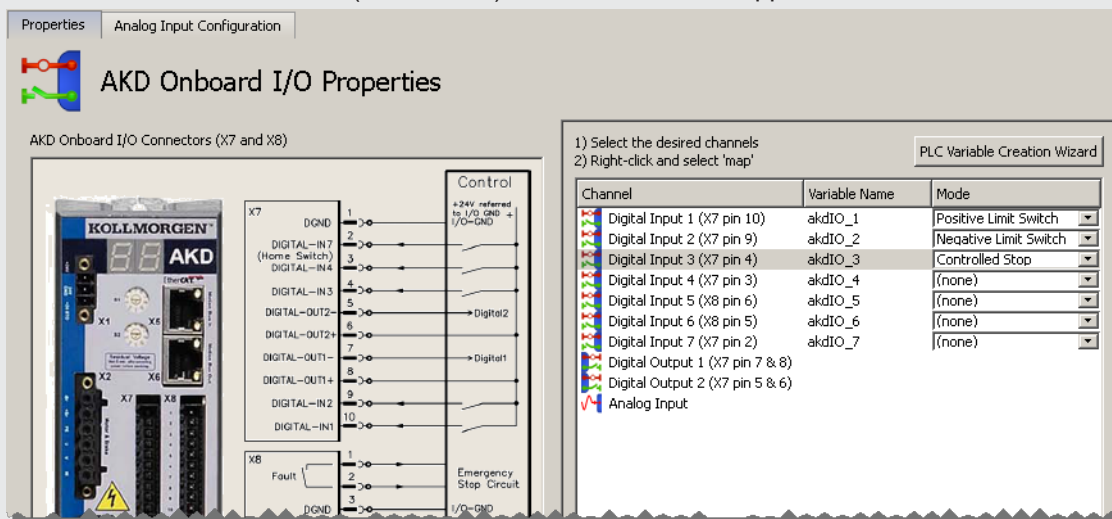

The 'Digital Inputs and Outputs' are now accessed using the new AKD GUI integration inside KAS. This will allow you to save this setting inside the drive instead of pushing it every time the application is started.

Files created with KAS 2.5 or earlier, with specific mode settings for any Digital Input of an AKD drive, will automatically be converted to the new project format and these settings will be removed. A dialog box will pop up prior to removal to inform you which settings will be removed from the project.

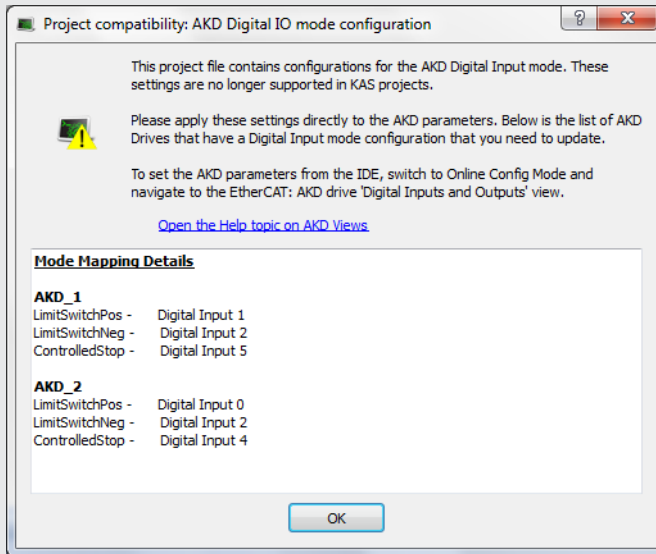

For each drive you will find the list of digital inputs with their specific mode settings. You can copy/paste the content of this text area to a text editor to keep track of them before closing the dialog box.

4.11.5.6.1 How to configure Digital Input mode setting inside WorkBench

To set the mode of a Digital Input

1. Connect to the controller
2. Go to "Online Configuration Mode" (→ p. 255)
3. Open the desired drive's WorkBench by double-clicking on the AKD drive node in the project tree view.
4. Open the Digital Inputs and Outputs view

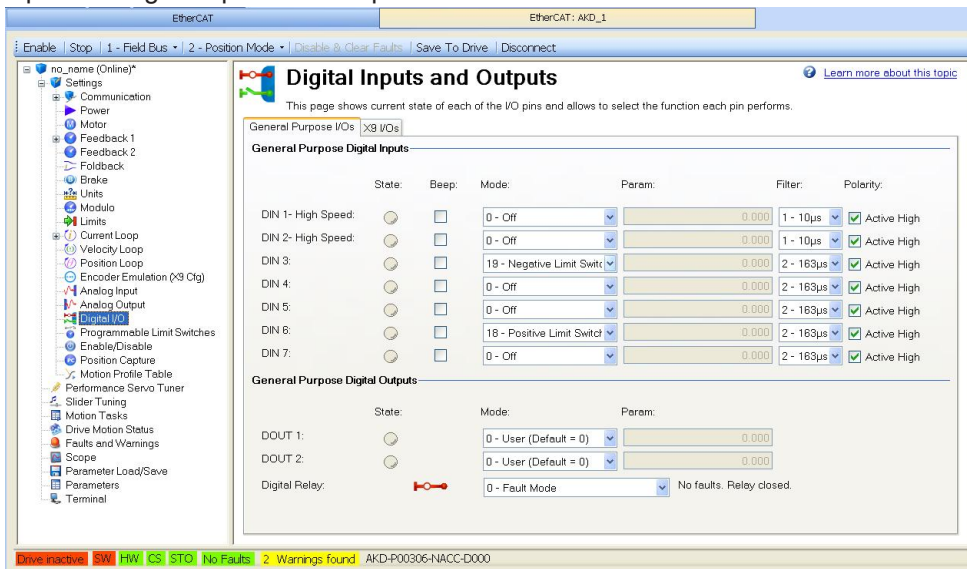

On this screen, you can set the mode of each Digital IO on the drive using the dropdown list in the Mode column. For more information about this view see .

4.11.6 Add and Configure a Stepper Drive

Following are the steps for adding an AKT2G-IO-SM-L15-000 or AKT2G-IO-SM-L50-000 stepper drive to your project.

1. Add an AKT2G-IO stepper I/O slice to your project. See "Add and Configure I/O Slices" (→ p. 201) for details.
2. Configure the device. See "AKT2G-IO-SM-Lxx Stepper Drive Configuration tab" (→ p. 196)
3. Assign variables to the I/O. See "AKT2G-IO-SM-Lxx Stepper Drive I/O Tab" (→ p. 196)

4.11.6.1 AKT2G-IO-SM-Lxx Stepper Drive I/O Tab

This tab is used to assign PLC variables to device I/O.

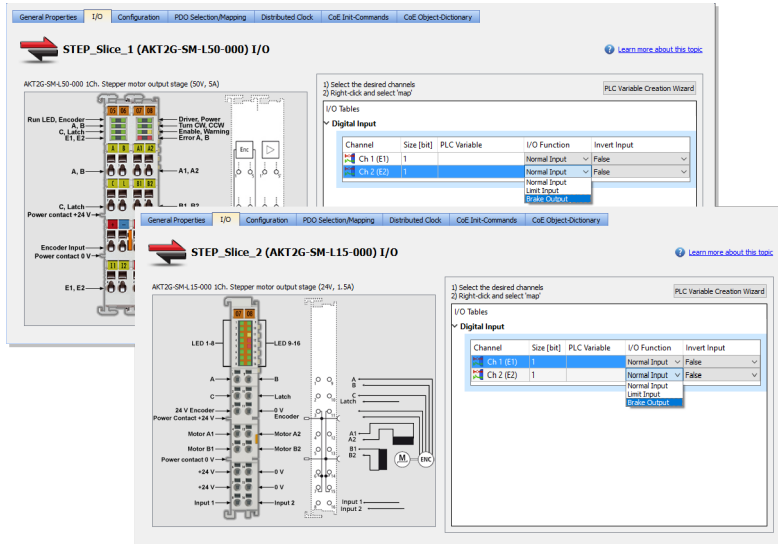

Element	Description
PLC Variable	A PLC variable may be assigned to each channel. Double-click (or right-click and select Map) to open the PLC Variable Selector to choose or create a variable. Alternatively you may use the "PLC Variable Creation Wizard" (→ p. 317) to automatically create a list of variables for mapping.
I/O Function	The AKT2G-IO-SM-Lxx stepper slices provide two digital inputs. <ul style="list-style-type: none"> • Normal Input: This selection configures the I/O channel as a normal input. • Limit Input: This selection configures the I/O channel as the hardware limit switch. The drive is disabled when a digital input acting as a source for the hardware limit is triggered. • Brake Output: This selection configures the I/O channel as the Brake Output. This option is supported only for the second I/O channel on the terminal.
Invert Input	This option inverts the state of the input when set to True. This is set to False by default. This setting is applicable only when the I/O channel is configured as either Normal Input or Limit Input .

TIP

- See "Add and Configure I/O Slices" (→ p. 201) for adding a stepper drive to your project.
- See AKT2G-IO-SM-L15-000 or AKT2G-IO-SM-L50-000 for information on the devices.
- See AKT2G-IO-SM-Lx Object Description for stepper drive-specific object descriptions.

4.11.6.2 AKT2G-IO-SM-Lxx Stepper Drive Configuration tab

This tab is used to configure the device, based on the parameters of the stepper motor being used, and to diagnose any problems with the stepper terminal.

- To make configuration simple, a Kollmorgen stepper motor can be selected from the "Properties tab" (→ p. 197).
 - This automatically populates the stepper motor parameter fields.

- The stepper motor parameters can be replicated to a file and transferred between devices.
 - Once the project is compiled, the "CoE Init Commands tab" (→ p. 356) is populated based on these values.
- Troubleshooting the stepper terminal can begin by gathering information from the "Diagnostics tab" (→ p. 200).

4.11.6.2.1 Properties tab

STEP_Slice_1 (AKT2G-SM-L50-000) Configuration

Properties | Diagnostics

Select a Motor:

Mode	Mode	Open-Loop with No Encoder	Open-Loop modes set the actual position source to the commanded stepper counter or encoder feedback.
Drive	Input Voltage (VDC)	24	Input supply voltage [SM-L50: 8 to 50 VDC; SM-L15: 24 VDC (-15%/+20%)]
	Reverse Motor Polarity	False	Reverses the motor direction.
	Kp (current control)	146	Kp factor for current control.
	Ki (current control)	60	Ki factor for current control.
	Fan Cartridge present	False	Enable when Fan Cartridge is installed. See 'Rated Current' field description for more details.
Motor	Full Steps per Revolution	200	The number of full motor steps (not micro-steps) per revolution.
	Rated Current/Phase (Amps)	0.53	Output Current/Phase in Amps. [SM-L50: 5 Amp max, 6.5 Amp max with fan; SM-L15: 1.5 Amp max, 3 Amp max with fan]
	Reduced Current (Amps)	0.265	Reduced coil current in Amps. If there is no motion for > 1 sec, the reduced current is applied.
	Phase Resistance (Ohms)	6.7	Internal resistance of the motor in Ohms.
	Phase Inductance (mH)	2	Inductance of the motor in millihenries.
Encoder	Counts per Revolution	4096	The number of encoder counts per revolution.
	Reverse Direction	False	Reverses the encoder direction

Select a Motor

The drop-down list contains the Kollmorgen stepper motor models and their specific parameters.

- Selecting a model automatically populates the appropriate motor-specific fields.
- See the [Kollmorgen Stepper Optimizer](#) to match a motor series name to the model number.

Reset to Default Values

Click to change all of the stepper motor parameters to their default values.

Load from File...

Click to select an XML file to populate all of the stepper parameters, not just those specific to the motor.

Save to File...

Click to create an XML file containing all of the current stepper parameters. This file can be stored or transferred between devices.

4.11.6.2.2 Mode Section

Element	Description
Mode	<p>Select the CoE object used for the actual position.</p> <ul style="list-style-type: none"> Open Loop with No Encoder Feedback: Select this option when there is no position feedback device for the stepper motor. In this mode: <ul style="list-style-type: none"> The command position increments sent to the stepper drive are accumulated in an internal counter and returned to the controller as the actual position. The PLCopen and Pipe Network axis motion function blocks (e.g., MC_ReadActPos, MLAxisReadActPos) return actual position. <ul style="list-style-type: none"> This is the stepper drive's internal counter. The controller commands position without considering position feedback. There is no assurance that the motor will get to its destination. Open Loop with Encoder Feedback: In this mode: <ul style="list-style-type: none"> The command position increments sent to the stepper drive are accumulated in an internal counter. <ul style="list-style-type: none"> The encoder feedback is returned to the controller as the actual position. The PLCopen and Pipe Network axis motion function blocks (e.g., MC_ReadActPos, MLAxisReadActPos) return actual position. <ul style="list-style-type: none"> This is the encoder feedback counter. The controller commands position without considering position feedback. There is no assurance that the motor will get to its destination because there is no ability to self-correct. Configure via CoE Init-Commands: This mode allows for custom drive/motor configurations. In this mode: <ul style="list-style-type: none"> The "Drive Section" (→ p. 198) and "Motor Section" (→ p. 199) configurations listed in this table do not apply. Stepper motor configuration parameters (e.g., Features, Controller, Motor, Encoder, etc.) must be configured manually in the "CoE Init Commands tab" (→ p. 356).
<p>NOTE</p> <p>When a custom configuration is required by your application, contact Kollmorgen Customer Support at support@kollmorgen.com.</p>	

4.11.6.2.3 Drive Section

Element	Description
Input Voltage (V _{DC})	<p>Specify the input supply voltage. The range is:</p> <ul style="list-style-type: none"> SM-L15 = 24V_{DC} (-15%/+20%) SM-L50 = 8 - 50V_{DC}
Reverse Motor Polarity	Select True or False from the drop-down menu to reverse the motor direction.
Speed Range	Select the maximum output full-step frequency from the drop-down list.
Kp (current control)	Specify the proportional gain factor for current control.
Ki (current control)	Specify the integral gain factor for current control.
Fan Cartridge Present	<p>Set this to True if a AKT2G-AC-FAN-001 fan cartridge is installed. Having a fan present allows you to set the "Rated Current / Phase (Amps)" (→ p. 199) to a higher value.</p>

4.11.6.2.4 Motor Section

Element	Description
Full Steps per Revolution	Specify the number of full motor steps per revolution.
Rated Current / Phase (Amps)	<p>Specify the motor's rated current per phase in Amps.</p> <ul style="list-style-type: none"> This is also known as the RMS (root mean square) current. <ul style="list-style-type: none"> This value is converted from RMS to Peak output current, by multiplying the value by 1.414 (square root of 2) to specify the maximum output current for the stepper drive. The 64x microstep resolution causes a 30% current loss compared to full-step resolution. <ul style="list-style-type: none"> This is due to the output wave form being closer to a sine wave than a square wave. The rated current/phase value is converted to the peak output current to compensate for the current loss. Since the peak output current may exceed the motor's rated current per phase at standstill, it is very important to configure the "Reduced Current/Phase (Amps)" (→ p. 199), to prevent the motor from overheating. <p>Maximum Motor Current/Phase (RMS) Values</p> <ul style="list-style-type: none"> SM-L15 = <ul style="list-style-type: none"> 1.06 Amps without a fan 1.12 Amps with a fan SM-L50 = <ul style="list-style-type: none"> 3.53 Amps without a fan 4.59 Amps with a fan <p>Maximum Converted Peak Output Values</p> <ul style="list-style-type: none"> SM-L15 = <ul style="list-style-type: none"> 1.5 Amps without a fan 3 Amps with a fan SM-L50 = <ul style="list-style-type: none"> 5 Amps without a fan 6.5 Amps with a fan
Reduced Current/Phase (Amps)	<p>Specify the motor's current per phase in Amps when at standstill.</p> <ul style="list-style-type: none"> This is known as the RMS (root mean square) current. <ul style="list-style-type: none"> This value is converted from RMS to Peak output current by multiplying the value by 1.414 (square root of 2) to specify the maximum output current for the stepper drive when the motor is at standstill. The Reduced Peak Current is applied when there is no motion for > 1 sec. <ul style="list-style-type: none"> At a minimum, the Reduced Current/Phase can be set to 70% of the "Rated Current / Phase (Amps)" (→ p. 199). Setting the Reduced Current/Phase to 50% (or lower) of the Rated Current/Phase is recommended.
Phase Resistance (Ohms)	Specify the internal resistance of the motor in Ohms.
Phase Inductance (mH)	Specify the motor's inductance in millihenries.

4.11.6.2.5 Encoder Section

Element	Description
Counts per Revolution	Specify the number of encoder counts per revolution.
Reverse Direction	Select True or False from the drop-down menu to reverse the encoder direction.

TIP

- See "Add and Configure I/O Slices" (→ p. 201) for adding a stepper drive to your project.
- See AKT2G-IO-SM-L15-000 or AKT2G-IO-SM-L50-000 for information on the devices.
- See AKT2G-IO-SM-Lx Object Description for stepper drive-specific object descriptions.

4.11.6.2.6 Diagnostics tab



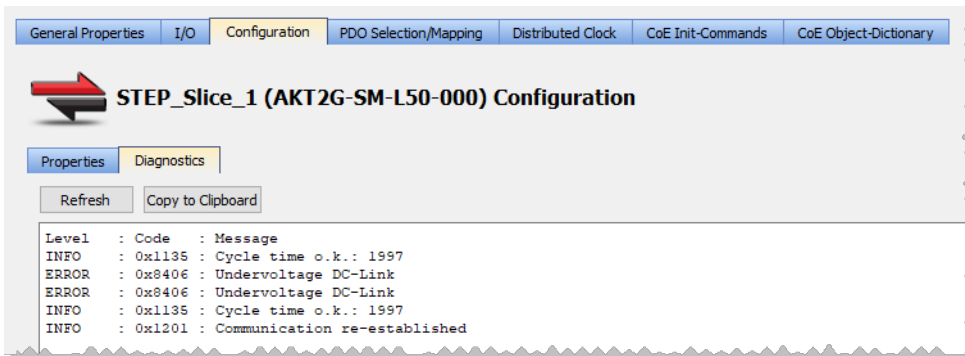

This tab gathers the diagnostic messages available on the connected stepper terminal.

- This information can be used for troubleshooting during commissioning or operation.
- The PLC application must be running on a controller or Online Configuration mode must be enabled to acquire diagnostics data.



Refresh	Click this button to read and view the stepper terminal's messages. See AKT2G-SM-Lxx Diagnostic Messages for a comprehensive list of messages. This button is disabled under these conditions. <ul style="list-style-type: none"> • The PLC application is neither running nor in online configuration mode. • A stepper I/O slice is not present on the EtherCAT network (e.g., offline device). • The PLC application is running on the KAS Simulator.
Copy to Clipboard	Click to copy the message data.

If the application is not running, follow this procedure.

1. Connect to your controller. 
2. Compile and download the application. 
3. Enable "Online Configuration Mode" (→ p. 255). 
 - OR -
 - Start the application. 

4.11.7 Add and Configure I/O Slices

This topic discusses adding AKT (K-Bus) and AKT2G-IO (EtherCAT/E-Bus) I/O devices. All devices are children of the EtherCAT node in the Project tree.

- AKT2G-IO (E-Bus) devices are each directly under the EtherCAT node.
- AKT (K-Bus) slices are children of the coupler, which is a child of the EtherCAT node.

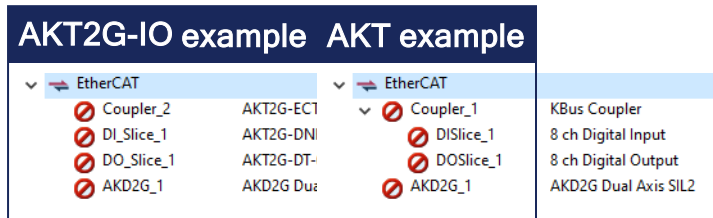

For local I/O, see Configure Onboard I/O (→ p. 194).

4.11.7.1 Add an AKT (K-Bus) I/O Coupler

1. In the Project Explorer, right-click the EtherCAT node to open the menu.
2. Select the **Add Device** command.
(this option is only enabled when you are **not** connected to the controller)

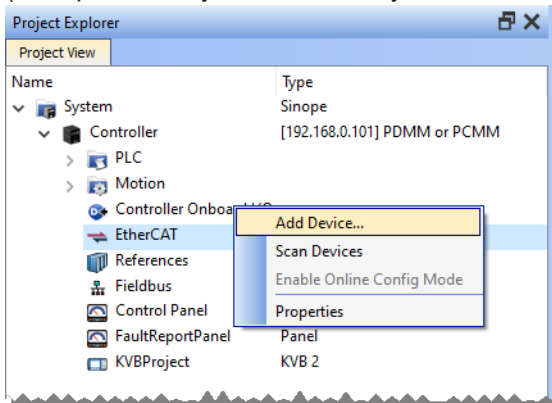

3. Select the coupler and click **OK**.
4. In the Project Explorer, right-click the coupler node and select the **Rename** command to change the name.
5. Click **OK**.
The coupler is added to the EtherCAT node.

4.11.7.2 Add an AKT (K-Bus) I/O Slice

1. In the Project Explorer, right-click the Coupler node to open the menu.
2. Select the **Add I/O Slice** command.
3. Choose the I/O slice from the list.

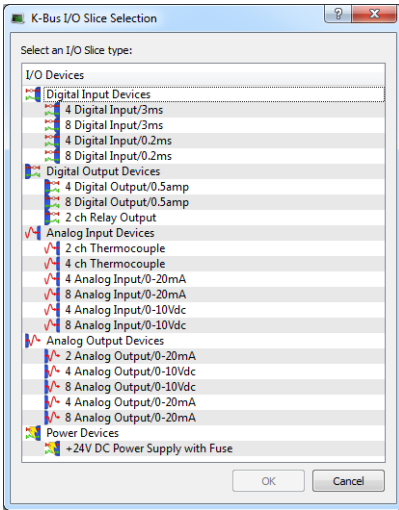
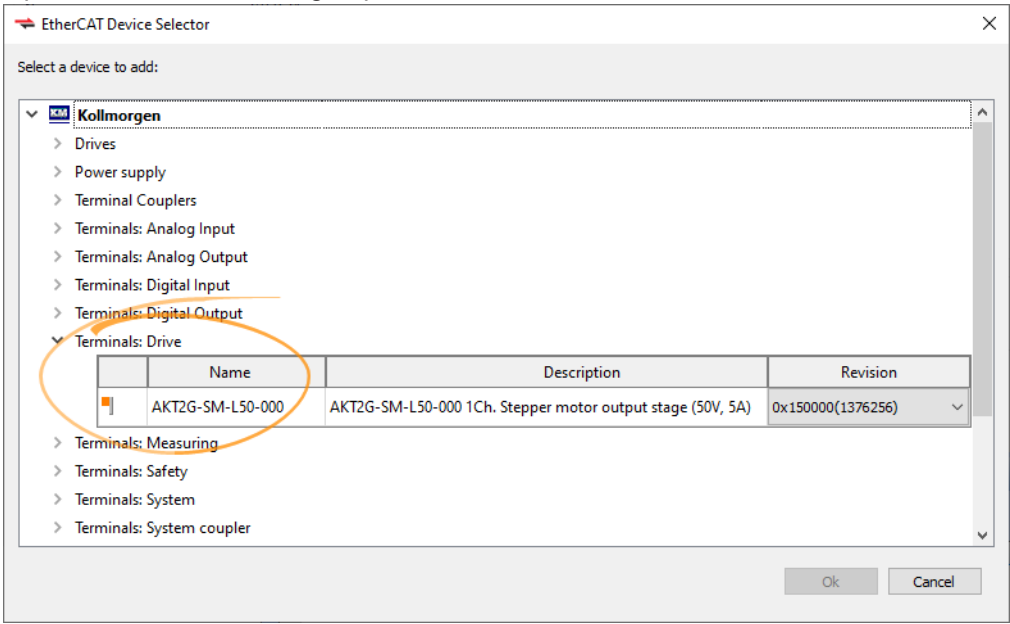

Figure 4-29: Add I/O Slice

4. Click **OK**.
The device is added below the coupler.

4.11.7.3 Add an AKT2G-IO Stepper Drive

1. In the Project Explorer, right-click the EtherCAT node to open the menu.
2. Select the **Add Device** command.
3. Open the Terminals:Drive group and choose a device from the list.



4. Click **OK**.
The device is added to the EtherCAT node.

For more information see:

- "AKT2G-IO-SM-Lxx Stepper Drive I/O Tab" (→ p. 196)
- AKT2G-IO-SM-L15-000 for product information
- AKT2G-IO-SM-L50-000 for product information

4.11.7.4 Configure the I/O Slice

For more details, see "Map Input and Output to Variables" (→ p. 314).

4.11.8 Add and Configure Third Party Devices

EtherCAT devices physically connected to the network can be scanned and discovered.

- EtherCAT devices can be manually added to the EtherCAT node in the Project view.
 - Manually added devices allow the project to be configured before connecting.

NOTE

- KAS-IDE does not support third-party drives.
- The KAS-IDE supports third-party FSoE Masters.
- BBH SCU-1-EC support is integrated with the KAS-IDE and is recommended.
 - Contact BBH for the latest ESI file that matches with the SCU-1-EC firmware version.
 - See the [BBH web-site for SCU-1-EC](#) for more information.
- Other third-party FSoE Masters are possible but require the FSoE/Connected PDOs to be configured manually by the user.

1. In the **Project View**, double-click the EtherCAT node and select the **ESI Files** tab.

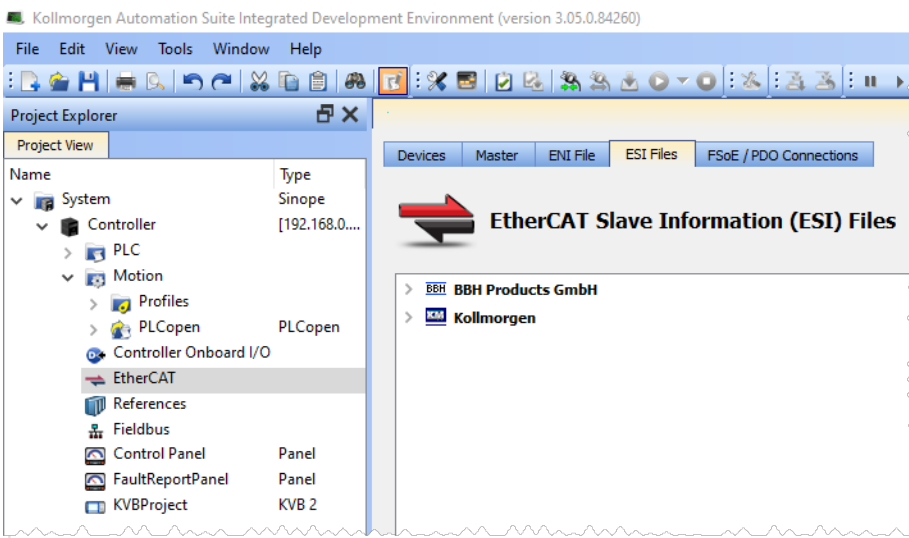

2. Use the **Add** button to add ESI files from a third-party vendor.

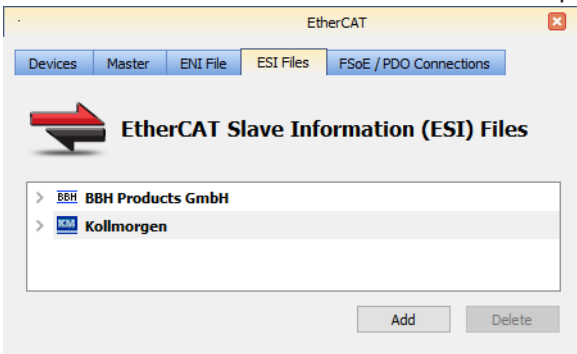

3. Navigate to where you have the third-party ESI file saved on your computer and click **Open**. This adds the manufacturer and device to the list of available devices.

4. Right-click the EtherCAT node and select **Add Device....**

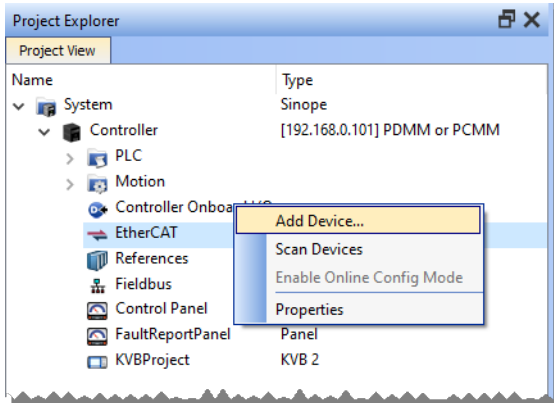

5. Select the device from the **EtherCAT Device Selector** dialog box.
If a specific revision number is required, it may be selected from the drop-down list in the revision column.
The default selection is the highest revision number.

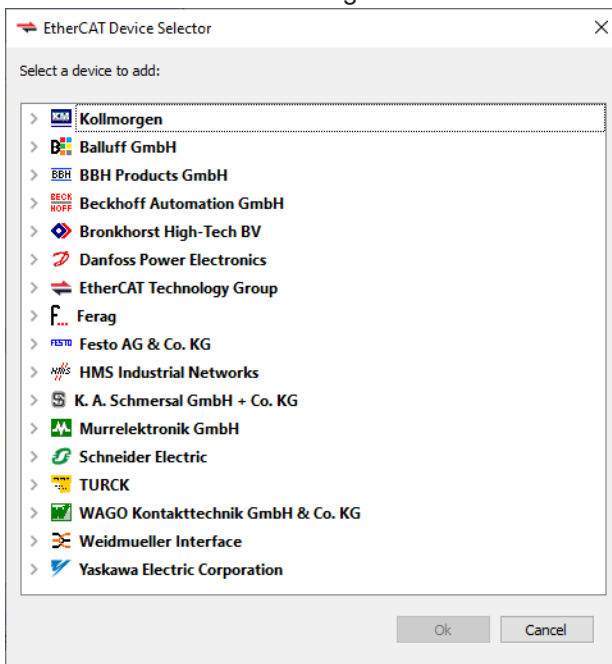

6. Click **Ok**.
The device is added to the project tree in the EtherCAT node.

4.11.8.1 Add Modules to Third Party EtherCAT Devices

Modules may be added to third party MDP (Modular Device Profile) EtherCAT devices in the Project view. This helps to pre-configure the EtherCAT network in the project before connecting to the controller.

1. Right-click a MDP EtherCAT device and select **Add Module...** from the menu.

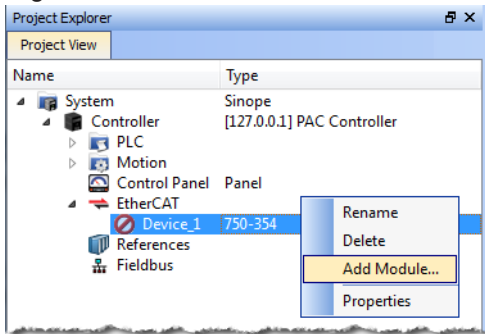

2. Select a module from the **EtherCAT Module Selector** dialog box.
3. Click OK.

The module is added to the project under the EtherCAT device.

4.11.8.1.1 Limitations

When adding modules from the Project View, there are several limitations to be aware of.

- Modules cannot be manually added to devices that are mapped to physical devices.
 - Modules are only added to an unmapped, manually added MDP device.
- Manually adding a MDP device does not automatically add mandatory modules.
 - Either:
 - Consult the device documentation to identify the mandatory modules and add them manually.
 - Discover the mandatory modules under the physical MDP devices, using the EtherCAT network scan.

4.11.8.2 Modules - General Properties Tab

A device may have no modules, or it may have several.

- Double-clicking or right-clicking on the module allows access to the General Properties tab.
- This tab provides information about the selected module.

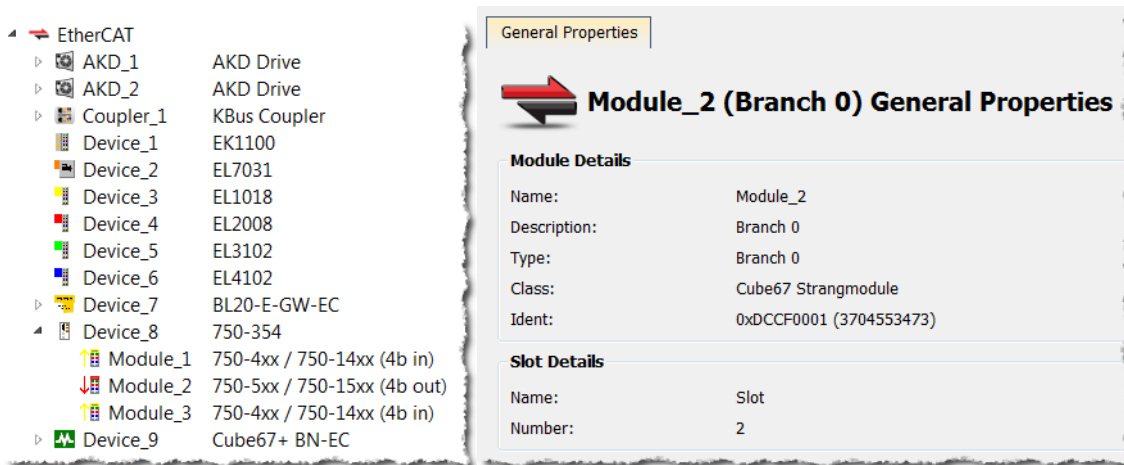

Figure 4-30: Devices in the EtherCAT list and the General Properties tab of a Device's Module.

The tab is divided into two sections, Module Details and Slot Details. Module Details provides the module's basic information.

Slot Details provides the module's slot information.

4.11.9 Use Pre-defined Libraries

The [Libraries](#) toolbox allows you to select the functions.

TIP

- The **(All)** category at the top enables you to see the full list of available blocks.
- You can access a specific function by entering its initial letters on the keyboard (if the elapsed time between two strikes is greater than 1 second, the KAS-IDE considers the last letter as the new initial).

Drag-and-drop into the editors

1. When the function is selected, move it with a drag-and-drop operation in the program editor
2. In the editor, right-click on a function to set the number of input pins if the block allows an extension.

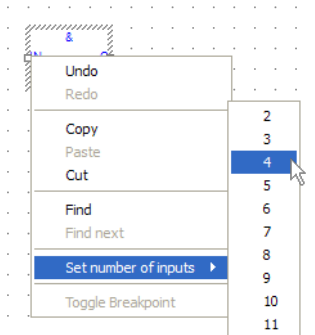

Figure 4-31: Set the Pins Number of the Block

Drag-and-drop into the dictionary

If you have selected a function block, you can drag-and-drop it in the program declaration within the Dictionary toolbox, to create an instance of that object.

4.11.10 Create and Use Custom Libraries

You need to create a custom library before you can use it to define a new item: function, function block or variable.

See "Use the Custom Library" (→ p. 210) for more information.

NOTE

There is a difference between **Libraries** usage and the **Import / Export** commands related to PLC programs.

- **Library** is a unique source that can be shared between different projects (like a dll in C): when you modify the library, all the linked projects are impacted.
- **Import/Export** is equivalent to a copy and paste operation of programs: when you update the source of your UDFB, the other programs are not updated because the code has been duplicated.

4.11.10.1 Create a Custom Library

1. In the **File** menu, click the **New** command (save your current opened project if necessary).
2. Select the **Library** application template.

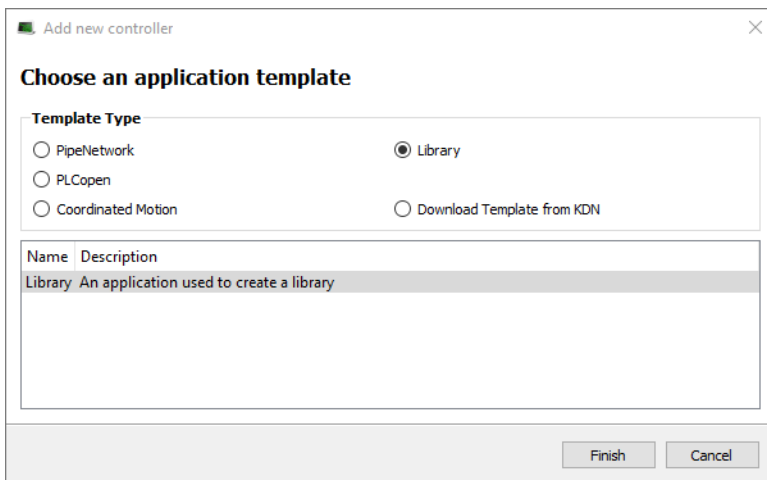
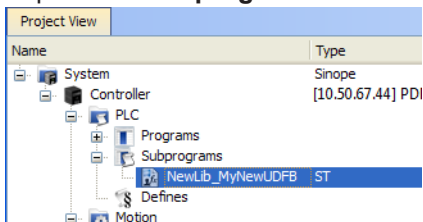

Figure 4-32: Create a Custom Library - Select the Library Template

3. Click the **Finish** button.
4. In the **File** menu, click the **Save As** command.
5. Define the Library Name (extension *.kal) and its Location.
6. Click **OK**.
7. In the Project Explorer, expand the **Controller** and **PLC** nodes.
8. Right-click on **Subprograms** and choose **New UDFB** in the contextual menu.
9. Select the type of programming language.
10. Expand the **Subprograms** node and rename the new UDFB.



NOTE

The name of the variable type is displayed in the dictionary if you use this library in another project.

ⓘ IMPORTANT

Duplicate UDFB names in a library are not possible.

Only the first instance found is kept when importing the library definitions in a project.
 To avoid this situation when designing your libraries, use a prefix to identify the library for all UDFBs and functions in the libraries (e.g., in the this procedure, the prefix is: NewLib_).

11. Create the UDFB program.
 See "Programs: Structure and Syntax" (→ p. 269) for more information.
12. In the **File** menu, click the **Save** command.

4.11.10.2 Use the Custom Library

1. Open the project where you want to use a library.
2. In the Project Explorer, expand the **Controller** node.
3. Right-click **PLC** and select **Libraries** in the menu.
4. Click **Add**.

NOTE

You can add as many external libraries as you want.

5. Select a previously created *.kal file and click **Open**.

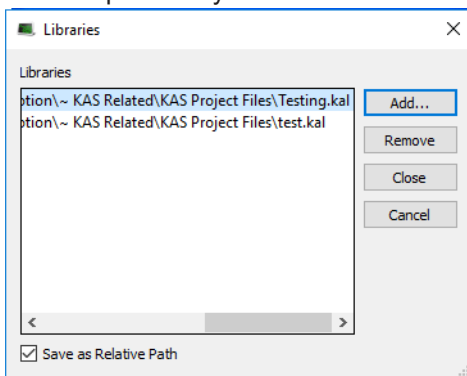

Figure 4-33: Use a Custom Library - Select the Library

TIP

You can use the **relative** path to specify the path relative to the working directory where your project is saved.

This ensures consistency when you move your project and your library.

Conversely, the **absolute** path points to the same location on your file system regardless of your project directory.

6. Click **Close**.
 The library is displayed in the Library widget and you can now drag-and-drop the UDFB (or any subprogram) of this library in any editor.

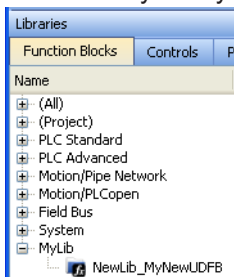

Figure 4-34: Use a Custom Library - Display the Library

7. In the Dictionary toolbox, right-click the program and select **Add variable**.

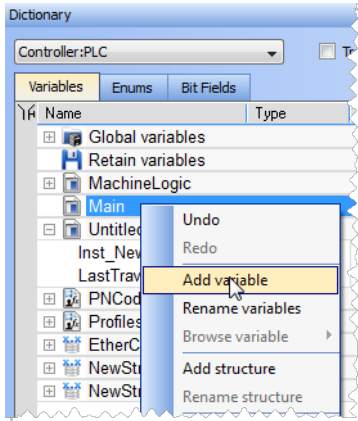

Figure 4-35: Use a Custom Library - Add variable

8. In the **Type** drop-down menu, select the type defined in the external library (it can be at the bottom of the list).

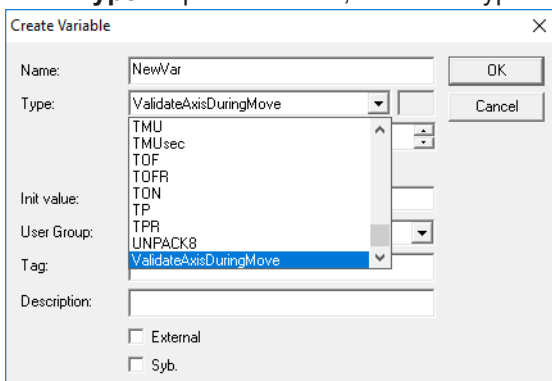
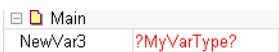

Figure 4-36: Use a Custom Library - Select the Type

What happens when you remove a library from your project?

If you remove a library from your project, all its types are removed from your project and all variables based on the library are displayed in the dictionary in **red** with question marks.



What happens when a library no longer exists?

If you open a project containing a link on a library which is no longer available, a warning is displayed:

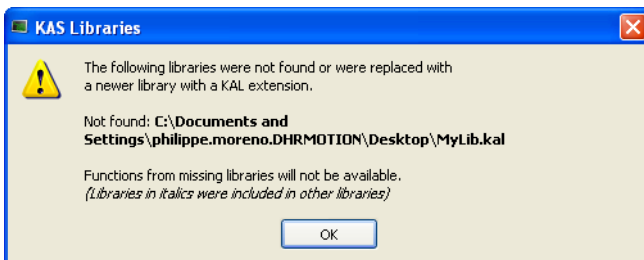

To recover the libraries, you have two options:

- Enter the new path to this library (assuming it still exists on your machine) using the library dialog (see "Use the Custom Library" (→ p. 210)).
- Find the missing library and copy the library back to the path originally specified. Note that the project has to be closed and re-opened for the library to be read again.

Broken link displayed in *italics*

If a library references another library which is no longer available, a dialog with the library link that causes the problem is displayed in italics.

Example: If your project has referenced LIB-4, which in turn references LIB-1-ND, but LIB-1-ND does not exist. To recover your project, open LIB-4 and fix the issue (i.e., LIB-1-ND broken link), then re-open this project again.

4.11.11 Adding Cam Profiles

4.11.11.1 Create a CAM Profile

1. In the Project Explorer, right-click the **Profiles** item and click the **New profile** command.

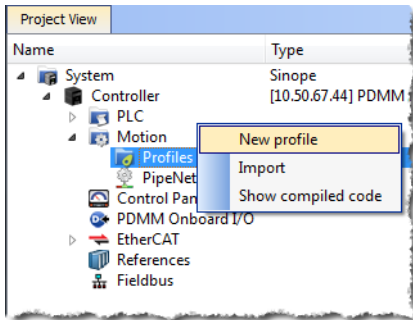

Figure 4-37: Cam - New Profile

2. A new profile named **Profile** is created with default parameters.
3. Right-click the new profile to rename it or change its properties.

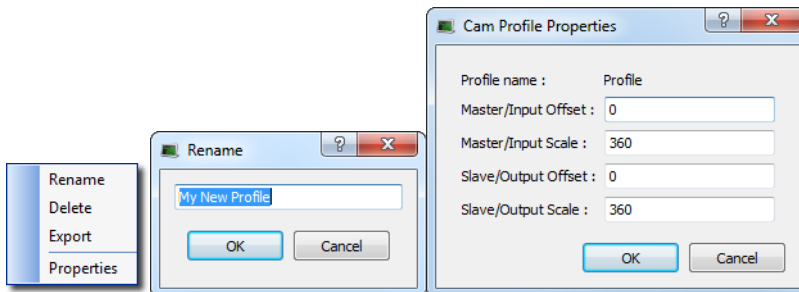
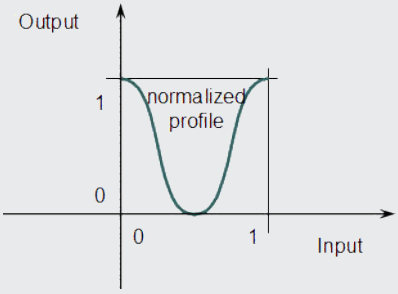
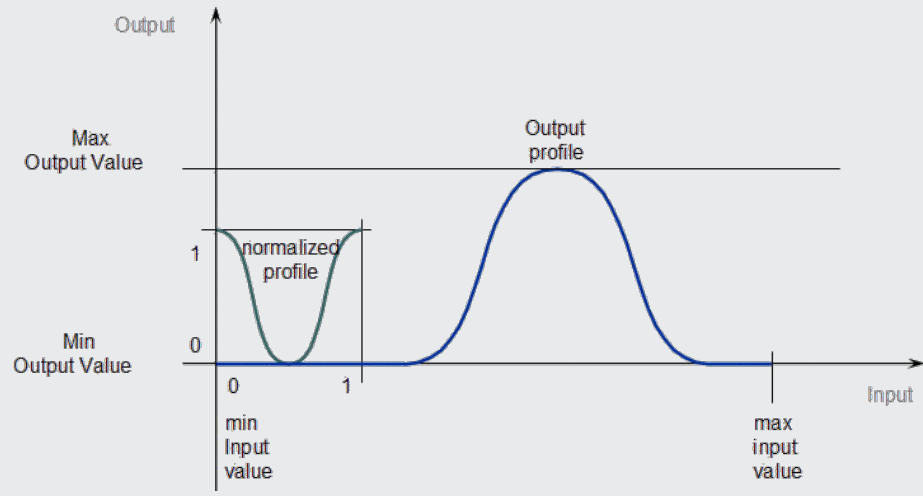

Figure 4-38: Cam - Define Profile Filename

4. Click the new profile to edit it.

4.11.11.1.1 CAM Profile Parameters

Field	Description
Profile name	The name of the Profile which is: <ul style="list-style-type: none"> • Shown in the Project Explorer • Used in the Properties of the CAM Pipe Block. • See "Use Cam Profiles" (→ p. 216) for more information.

Field	Description
Master/Input Offset Master/Input Scale Slave/Output Offset Slave/Output Scale	<p>Offsets and scales on the X and Y axes transform the normalized profile into the output profile as shown in these images:</p>  <p>Figure 4-39: Cam - Normalized Profile</p>  <p>Figure 4-40: Cam - Output Profile</p> <p>See "Four Parameters Transforming the CAM Profile" (→ p. 214) for more information.</p>

4.11.11.1.2.1 Four Parameters Transforming the CAM Profile

Four Parameters Transforming the CAM Profile

Master/Input offset

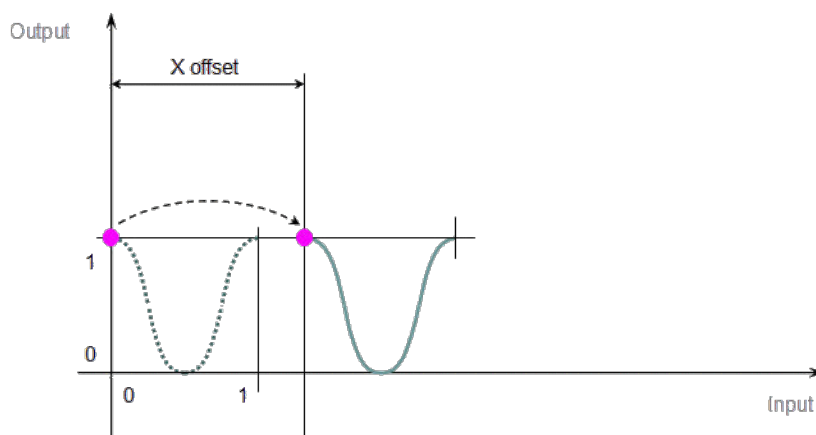

Figure 4-41: CAM Profile Transformation - Step 1

Master/Input scale

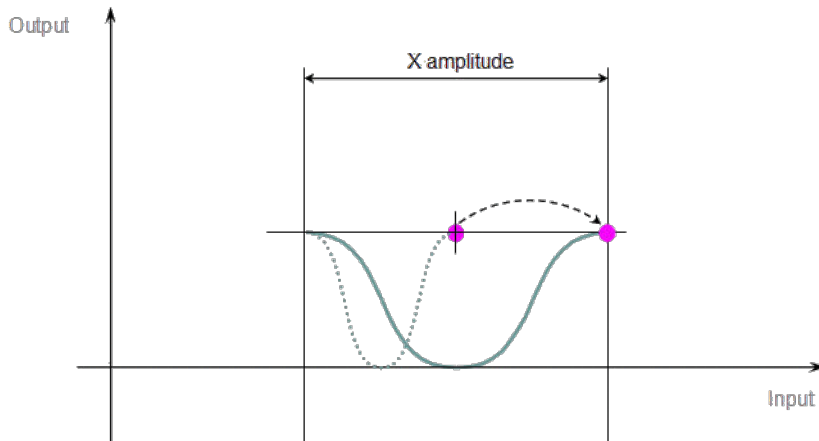

Figure 4-42: CAM Profile Transformation - Step 2

Slave/Output scale

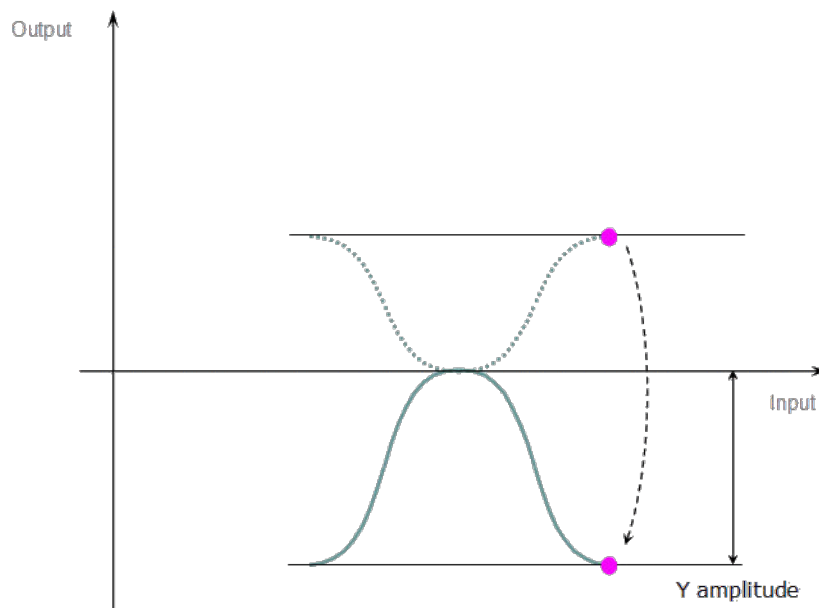

Figure 4-43: CAM Profile Transformation - Step 3

Slave/Output offset

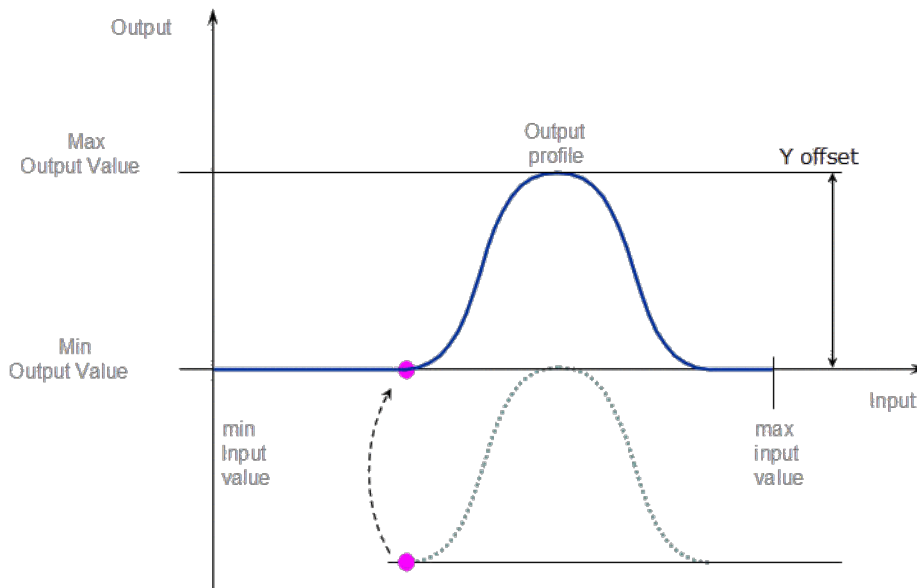

Figure 4-44: CAM Profile Transformation - Step 4

NOTE

When a CAM Profile property is changed, a dialog box indicates the progression of the operation.

See Also

- "Cam Profile Editor" (→ p. 444)
- "Use Cam Profiles" (→ p. 216)

4.11.11.2 Use Cam Profiles

Once defined (see "Create a CAM Profile" on page 213), you can associate a cam profile to a cam Pipe Block in the Pipe Network as follows:

1. Right-click on the cam Pipe Block and select **Properties** in the menu
2. In the **Parameters** tab, enter the profile's name

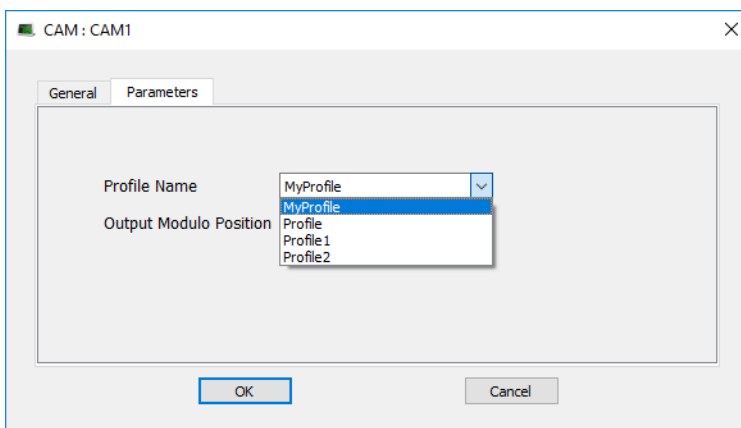

Figure 4-45: Cam - Associate Profile to a Pipeblock

NOTE

Separating the declaration of the cam Pipe Block from the cam profile provides the capability to prepare several different cam profiles and then apply one of them to the cam Pipe Block.

NOTE

If you change the profile's filename, do not forget to update the cam Pipe Block accordingly.

4.11.11.3 CAM Profile Switching

At pipe network start-up or when using the MLCamSwitch function block, a CAM block's output position is set to the output position of the initialized profile.

Assume

- This profile is switched on.
- The present pipe network position is:
 - 150 at the input of the CAM block.
 - 50 at the output of the CAM block.

Result

- As the input to the CAM block increases or decreases, the CAM output value increases or decreases respectively.
- It will go through the modulo without a position jump.

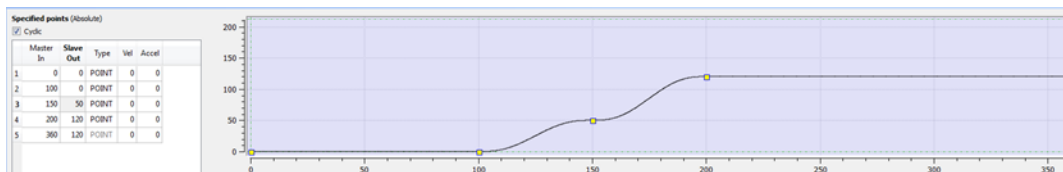

4.11.12 Define Scheduling

4.11.12.1 Periodicity

The period of execution of a pipe is the time spent between two successive computations of set values for the same pipe. The period of execution of a pipe is specified by the PERIOD parameter of the input Pipe Block.

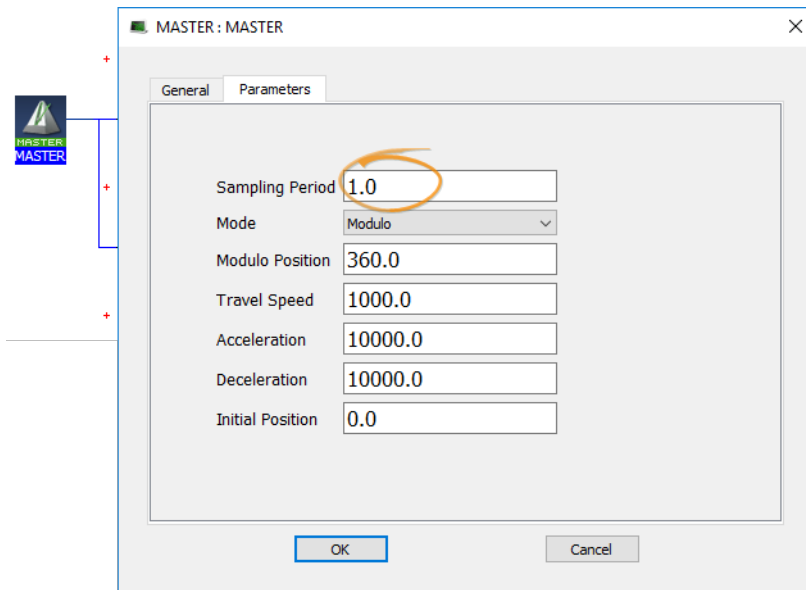
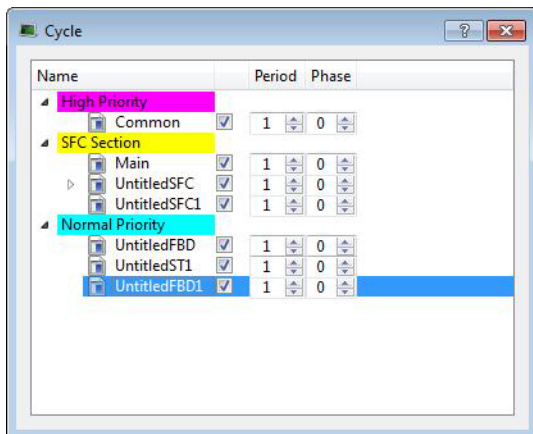

Figure 4-46: Set the Period of Execution

All the pipe values are computed independently of events and sequences execution.

4.11.12.2 Order of Execution

The order of execution of programs within a project is determined from the Cycle window.



The order of execution is always

1. High Priority
2. SFC Section
3. Normal Priority

The order within each grouping is determined by the vertical ordering. Using the image above, the order of execution for Normal Priority programs is:

1. UntitledFBD
2. UntitledST1
3. UntitledFBD1

For more information see "Define the PLC Cycle" (→ p. 219).

4.11.12.3 Define the PLC Cycle

The cycle specification defines the number of cycles between successive executions of the programs.

1. In the Project Explorer, expand the PLC node and right-click on the Programs item to open the contextual menu and select the **Cycle** command

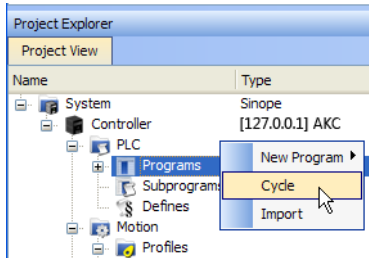

Figure 4-47: Edit the Cycle

The Cycle window allows the regulation of the following parameters: Period and Phase.

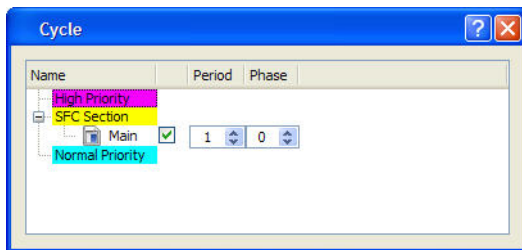

Figure 4-48: Define the Cycle

The cycle configuration dialog box is used to configure the programs priority into the Virtual Machine.

Cycle Parameters

Column	Description
Name	List of PLC programs grouped together by priority level. The priority defines the order of execution. The SFC programs have a specific section as they must be grouped together. <i>High Priority</i> means "executed before SFC", and <i>Low Priority</i> means "executed after SFC".
Check box	Enables or disables the execution of the corresponding program.
Period	Defines how many cycles are set between two executions of the program. You can define various sampling periods for programs of the application. Default period is "1" (the program is executed on each cycle). Giving a slower period to some programs is an easy way to give higher priority to some other programs.
Phase	Defines an offset that enables you to dispatch slow programs among few cycles. The goal of postponing the program execution is to reduce execution peak loads. Example: a program with period=2 and Phase=1 is executed each even cycle a program with period=2 and Phase=0 is executed each odd cycle

In the **High** and **Normal** Priority sections, adjust the order of the programs with a drag-and-drop operation according to the expected sequence. In each section, the program on the top is executed first.

Select the program you want to set with a higher priority, then drag and drop it to the relevant priority level.

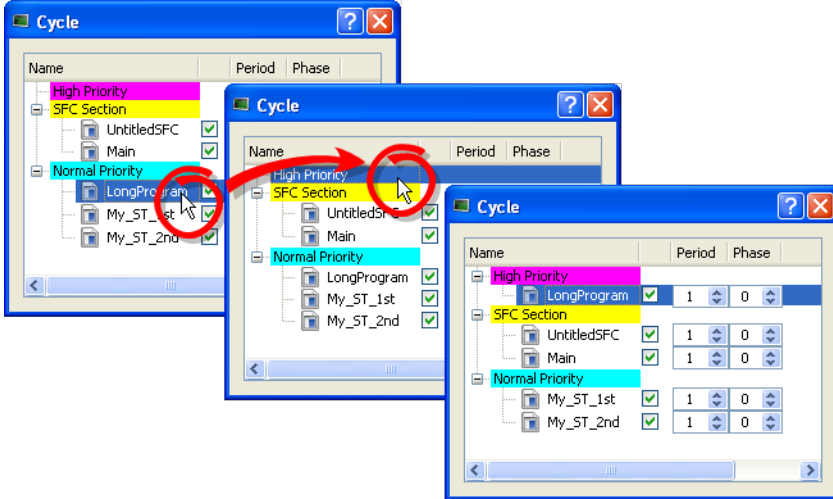

Figure 4-49: Change Priorities by Defining the Cycle

If all programs are with a Period set to 1, the KAS-IDE is more loaded. The choice of the Period for the programs gives you the possibility to distribute the load of the application.

also see "Tasking Model / Scheduling" on page 819 and "Order of Execution" (→ p. 218).

4.11.12.3.1 Specify the Duration of a Cycle

This parameter is defined in "EtherCAT Master Settings tab" (→ p. 327).

4.11.12.3.2 Ensuring Variables are Exported

Program Organization Units (POUs) which contain variables (see "Map Variables to HMI" (→ p. 186)) must be compiled for the variable to be exported.

Example: In these images, a POU (*UntitledST*) has two variables, *NewVar* and *NewVar1*.

1. Only *NewVar1* is set to be exported (1).
2. The POU, however, is not set to be executed in the Cycle dialog box (2).
3. This causes a compile error (3).

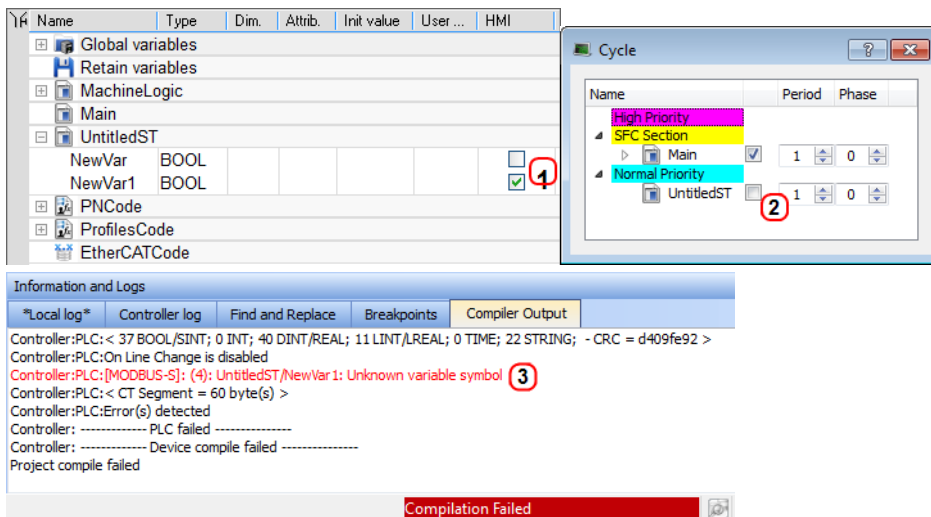

Figure 4-50: Example of a variable not being exported and the resulting compile error.

4.11.12.4 About Parent-Child relationships and execution order

The SFC Section allows for editing the period and phase values of parent and child programs. Parent and child programs follow certain rules:

- A parent program can be enabled or disabled. If a parent is disabled the child will also be disabled. A child program cannot be disabled.
- Parent programs are allowed to move across priorities. Child programs will follow the movement of a parent. Child programs are not allowed to move independently.
- When a child program is created or imported, it will inherit the enabled/disabled state of the parent program.
- The SFCs are executed at the set cycle period and phase. All parent programs will be executed first and then the children programs will be executed in order.

To understand the last rule, consider the following Cycle example. There are three parent programs, each with a number of child programs. All parents are executed, followed by the children, in order. The actual flow is illustrated below the image.

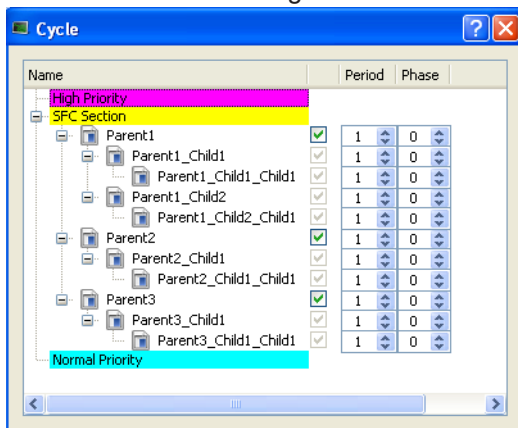

ⓘ IMPORTANT

Parent SFCs should run faster than their children. If this is not the case, the stop condition can be vague. When a child runs slower than its parent it does not stop when the parent stops, but at the child's next execution. This means the parent could execute more, while the child is still running.

🔗 TIP

A child program is initiated at Phase 0 in respect to its parent.

4.12 Run the Project

This section explains how to build, download and run your project.



Step	Description
1	Set the compilation options to run your project in Debug or Release modes, and choose if you want to activate the Online Changes
2	Compile the application and see all the remaining warnings and errors
<div style="background-color: #f0f0f0; padding: 5px;"> <p>NOTE</p> <p>Before step 3, you need to start the KAS software (KAS Simulator or KAS Runtime) on the target device where you want to run your project.</p> </div>	
3	Connect the KAS-IDE to the target device
4	Download the Application compiled on the KAS-IDE to the target device
5	Start / stop the device, and control your application with the script commands

4.12.1 Set the Compilation Options

Click the  icon to open the **PLC options** dialog box.

- Select the **Debug** option to use "Step-By-Step Debugging" (→ p. 231) during simulation or online testing.
- Select the **Release** option to if step-by-step debugging is not required and to give highest performance to the application.

When additional statements are incorporated in the code (e.g., trace outputs), you must select the **Debug** compiling mode so that they are taken into consideration (in RELEASE mode, those statements are not included).

For more information, see:

- "Conditional Compiling" (→ p. 223)
- "PLC Online Change" (→ p. 555)

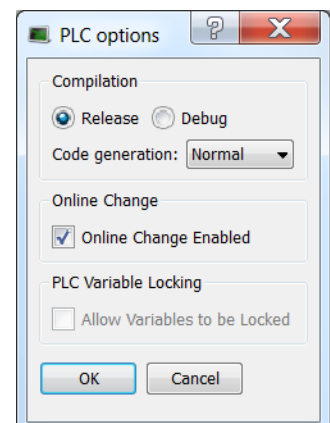

4.12.1.1 Code Generation

The code compilation options are: "Normal" (→ p. 222) and "Optimized" (→ p. 223).

4.12.1.1.1 Normal

- Normal code:
 - Allows the use of all PLC features in the KAS-IDE and Runtime.
 - Generation creates P-code and executes inside a virtual machine.
 - **Size Constraints:** The P-code is smaller than the same program translated to C-code.
- **Development and Debugging:** Normal code allows breakpoints, step through PLC code, and use online change.
 - Normal code is interpreted¹ so the interpreter can apply many additional runtime checks that would be harder to implement with Optimized code.

TIP

Using **Normal** code is recommended to take advantage of all KAS PLC features unless the controller is unable to meet performance requirements.

4.12.1.1.2 Optimized

NOTE

The Optimize Code option is not available for the PCMM2G.

Optimized code generation:

- Creates C code (i.e., C programming language).
- Is compiled into native machine code.
- Supported by AKD PDMM and PCMM controllers.
- Executes directly and is significantly faster, allowing the controller to run more complex and faster PLC applications.
- Has these limitations:
 - "PLC Online Change" (→ p. 555) is not available.
 - WAIT / WAIT_TIME are not supported.
- Has these disabled features:
 - "Breakpoints" (→ p. 232)
 - Debugging (see "Testing and Debugging the Project" (→ p. 231)).
 - "Step-By-Step Debugging" (→ p. 231)

4.12.1.2 Conditional Compiling

The compiler supports conditional compiling directives in ST, IL, FFLD, and FBD languages.

- Conditional compiling directives condition the inclusion of a part of the program in the generated code based on pragma.
- Conditional compiling is an easy way to manage several various machine configurations and options in one unique application project.
- Conditional compiling uses [definitions](#) as conditions.

This is the main syntax:

```
#ifdef CONDITION
    statementsYES...
#else
    statementsNO...
#endif
```

- If CONDITION has been defined using [#define](#) syntax, then the **statementsYES** part is included in the code, else the **statementsNO** part is included.
 - The `#else` statement is optional.

¹(The code is read by the KAS Runtime engine that then determines the instructions to run)

TIP

Intellisense facilitates the reading by coloring in gray the part of the program which is not active.

How to define conditional compiling directives?

Language	Description
FBD Language	Directives must be entered as the text of FBD Network Breaks
FPLD Language	<p>Directives must be entered as a network pragma with the  icon.</p> <p>In this example image:</p> <ul style="list-style-type: none"> • If CONDITION has been defined using <code>#define</code> syntax, then • The networks 2 to 4 are included in the code, else • The networks 5 to 12 are included.
	 <pre> Network #1 E-stop both axes when the E-stop button is pressed #ifdef CONDITION Network #2 Reset the axis errors of both axes when the Reset button is pressed Network #3 Close the servo loop and enable the drive when the Enable button is pressed. Open the servo loop and disable the drive when the Disable button or the E-stop button is pressed. Network #4 Close the servo loop and enable the drive when CloseLoop is high. Open the servo loop and disable the drive when CloseLoop is low. #else Network #5 Get the Axis 1 actual position for the Control Panel to display Network #6 Get the Axis 2 actual position for the Control Panel to display Network #7 Raw feedback positions Network #8 Read the states of the axes Network #9 If both axes have no errors and are enabled, turn on the Ready indicator Network #10 Monitor Velocity of each Axis Network #11 EtherCAT status word of each Axis #endif Network #12 Drive Fault observer End of Module </pre>
IL Language ST Language	<p>Directives must be entered alone on one line of text.</p> <pre> #ifdef DEF_A1_PeriodicAxis MLPhaSetPhase (PipeNetwork.PHASE1,DEF_A1_PosPeriod-A1_RefPos4); #else MLPhaSetPhase (PipeNetwork.PHASE1,DEF_A1_LinearPeriod -A1_RefPos4); #endif </pre>

NOTE

Conditional compilation do not apply to actions in an SFC step.

The condition `__DEBUG` is automatically defined when the application is compiled in [DEBUG mode](#).

This allows you to incorporate some additional statements (such as trace outputs) in your code that are not included in RELEASE mode.

```

#ifdef __DEBUG
    Printf('In debug mode', 0, 0, 0, 0);
#endif

```

See Also

also see "Run the Project" on page 222

4.12.2 Compile the Project

After creating all the elements of your project, you are ready to compile it. The project must be compiled before it is simulated or downloaded to the target.

Use the Compile button () on the toolbar (**Ctrl+B** shortcut) to compile the project.

The compiler reports messages in the Information and Logs toolbox.

See the "Compiler Output tab" (→ p. 115) tab.

No other actions are possible when the compilation is in progress.

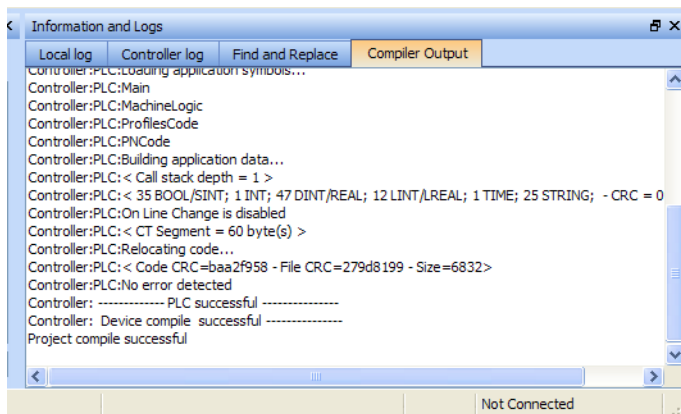

TIP

Errors are easily located using the information and logs window as shown below.

Double-click on an error in the list to open the program and jump directly to the relevant location in the editor.

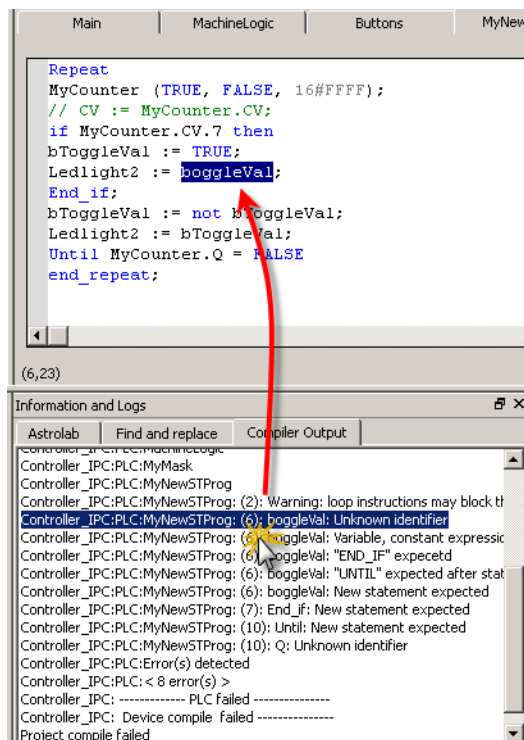

To locate source code, you can also use the **Find and replace** feature (for more information, refer to "Find and Replace tab" (→ p. 108))

NOTE

In FFLD, when a function, function block or UDFB is not connected on the left, then it is ignored (removed at compiling time).
This case only applies for functions - **not** for function blocks.

4.12.3 Start the KAS Simulator

Click the Simulator button in the toolbar to simulate your application.

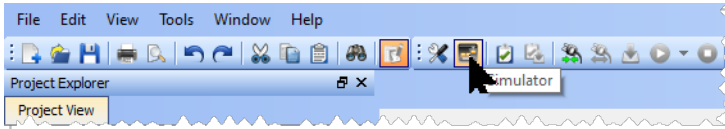







Once the program opens, start the simulation using the Control Panel.



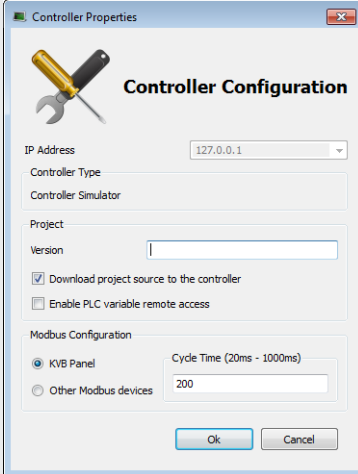

See also see "Using the KAS Simulator" on page 361.

4.12.4 Connect to the Controller

KAS provides all the commands for controlling the target in the **Device** toolbar:

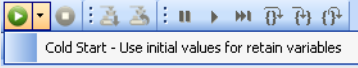

Icon	Description
	Show the controller communication properties dialog (PLC options).
	Change the controller IP address to connect with KAS Simulator. In this simulated mode, the controller properties change and the Controller Type includes the IP address 127.0.0.1.
	See "Using the KAS Simulator" (→ p. 361) for more information.
	Compile the project.
	Compile and download the project. This downloads the application and Project Source files.
	Establish a connection with the target controller. See the "Status Bar" (→ p. 123) for more information about statuses.

Icon	Description
	Close connection with the target controller.
	Download the application to the targeted controller. The application must not be running. See "Download the Project" (→ p. 228) for more information.
	Start the application. It can be either: <ul style="list-style-type: none"> • Warm Start (default mode): "Retain Variables" (→ p. 707) are loaded at the application startup. <ul style="list-style-type: none"> • They are Not re-initialized; whereas other variables are started with their initial values. • Cold Start: Use "Retain Variables" (→ p. 707) with their default values. Cold starts occurs from time to time but are few. <ul style="list-style-type: none"> • To choose a Cold Start, click the Start button drop-down: 
	Stop the application.

NOTE

If a previous download failed (due to the disconnected Ethernet or the controller is turned off), the application cannot be started.

Additionally:

- No version information is shown in the web server or status bar.
- The Start, Cold Start, and Download buttons are not available on the web server.
- If the AKD PDMM or PCMM tries to auto-start, an E24 error is flashed on the 7-segment display. Review the Controller logs for more information.

Verify the Simulated device mode is active (click the  button).

Click the **Connect Device** button () to establish the connection with the target controller.

NOTE

You need to configure the device before connecting.
See "Configure the Controller" (→ p. 135) for more information.

4.12.4.1 Actions to Prevent Compatibility Issues

The software versions of the KAS-IDE and the KAS Runtime have to match to avoid compatibility issues.

See "KAS-IDE to Runtime Compatibility" (→ p. 128) for more information.

TIP

The software versions of the KAS-IDE and the KAS Runtime are also available in the local log messages (the level for this message is INFO).

See "Information and Logs window" (→ p. 102) for more information.

When another KAS-IDE is already connected to the controller, a warning opens and the connection is discarded to prevent any conflict.

4.12.4.2 Application Status Bar

The status bar provides global information about the target and the name of the running application currently stored in the device.

orange background means that the version of the application is different between the KAS-IDE and the target. See [click here...](#) for more information.

4.12.4.3 Message Window

Every log message has this information:

- Timestamp
- ID
- Message
-



Once connected to the device, it is no longer possible to edit the PLC programs, unless Online Change is active.
See "Compile the Project" (→ p. 225).

ⓘ IMPORTANT

Depending on the number of AKD drives physically present in the EtherCAT network, the KAS-IDE might slow down when getting data.

The KAS Runtime is **not concerned** with this limitation.

4.12.5 Download the Project

Click the **Compile and Download** () button (**Ctrl + F7**) or the **Download** () button. The application is compiled and downloaded or just downloaded to the controller.

An alert appears if:

- An attempt to Compile and Download is made without a connection to a controller.
- There is not sufficient space on the controller for the application.
 - Clearing the "User Data tab" (→ p. 413) is one method to create more space on the controller.
- In the **Controller Properties** dialog box, if the **Download Project Source in the controller** option is:
 - **Enabled** - the source code is copied to the controller. See "Configure the Controller" (→ p. 135).
 - **Disabled** - and the controller has project source loaded, a message appears.
 - The message is different based on whether the current project and the project on the controller have the same name or not.

4.12.5.1 Project Name - Same Name

If the Project Name is the same, the message is:

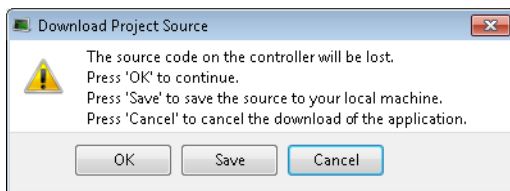

4.12.5.1.1 Actions

Click either:

- **OK:** Source on controller is deleted.
- **Save:** Source on controller is overwritten and is saved to "My Documents".
 - If that source file already exists in My Documents, a prompt appears to rename the source file, overwrite that file or not.
 - If the file is not renamed or overwritten, the download to the controller is canceled.
- **Cancel:** Download is stopped.

4.12.5.2 Project Name - Different Name

If the Project Name is different, the message is:

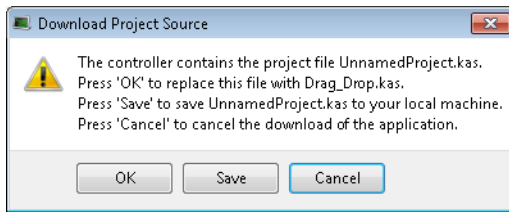

4.12.5.2.1 Actions

Click either:

- **OK:** Source on the controller is replaced.
- **Save:** Source on the controller is saved to **My Documents**.
- **Cancel:** Download is stopped.

NOTE

The versions between the KAS-IDE and the KAS Runtime must be the same to debug the application. Example: To view the "Variable Animation" (→ p. 240) in the editors.

ⓘ IMPORTANT

If the IDE version differs from the runtime after compiling an application, the function blocks defined in the IDE and those implemented in the virtual machine of the runtime can be different.

To prevent this potential mismatch, compile and download the application again.

👉 TIP

The project's source code can be downloaded to store the project. See the "File menu" (→ p. 251) about retrieving saved projects.

4.12.5.3 Application Status Bar

The tooltip of the application [status bar](#) gives more information about the application stored in the target: name of the project, name of the device, version of the application, its build number and date of compilation.

To view the tooltip, hold the mouse over the application status bar and wait for 1 or 2 seconds without moving the mouse.

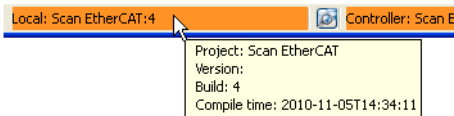



Figure 4-51: Device Tooltip displays Version

4.12.6 Device Control

4.12.6.1 Start / Stop the Device

With the KAS-IDE

Start / stop the device with the buttons  and .

With the KAS Runtime

In the KAS Runtime menu you can click the **start / stop** command.

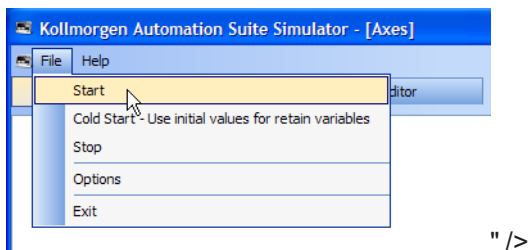

Figure 4-52: Start Device with the KAS Runtime

4.12.6.2 Log Window

The Log window displays all run-time messages issued by the device or by the KAS Simulator when testing the application.

The log area of the KAS-IDE and the KAS Runtime Simulator are the same. It contains the log messages as described in "Information and Logs window" (→ p. 102)

4.13 Testing and Debugging the Project

During system validation it is essential that the KAS-IDE allows you to monitor the application program execution and to capture critical events and their data when they occur.

A Control Panel, designed with an [internal editor](#), can be used to provide a basic interface.

4.13.1 Step-By-Step Debugging

To minimize risk, the KAS-IDE, in conjunction with the KAS Simulator, allows checking and validating the application program prior to deployment of the machine/system in production. This is achieved by capturing critical events in a **Step-By-Step Debugging** mode.

In addition to the cycle-by-cycle execution mode, the debugger has a collection of features for **Step-By-Step Debugging** in the source code of the application.

NOTE

Step-By-Step Debugging is only available if the project has been compiled with the **Debug** option.

This option is selected from the project compiling **PLC options** dialog box (accessed using the  button).

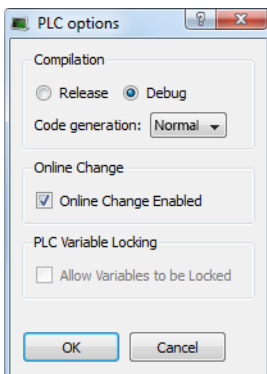

Figure 4-53: PLC Options - Debug Compiling Mode

- An application compiled in **Debug** mode includes additional information for stepping.
 - This leads to a larger code size and reduced performance.
- When debugging is finished, it is recommended to compile the application in **Release** mode to give highest performance to the application.

Step-By-Step Debugging is available in:

- FBD (a step is considered as a graphic symbol corresponding to an action).
- FFLD programs (a step is considered as a rung).
- ST and IL text programs (a step is considered as a statement).

ⓘ IMPORTANT

Step-By-Step Debugging is **not** possible in SFC programs. See "About SFC" (→ p. 234) for more information.

These are the options for entering the **Step-By-Step Debugging** mode:

- When a breakpoint is set in a program.
 - See "Breakpoints" (→ p. 232) for more information.

```



Untitled5T
Printf('Manual mode', 0, 0, 0, 0);
// Start motion
MLMstRun(PipeNetwork.Master 11, TravelSpeed 50.000000);
    
```

- When you start your application and the breakpoint is reached, the execution stops at the specified location.
 - You can run one step further in the program with the stepping commands.
- When the target is in cycle stepping mode (STOP).
 - You can step to the beginning of the first program.



TIP

Pausing a program does not interrupt the current VM cycle. The current cycle finishes and execution is paused before the beginning of the next VM cycle.

These commands are available from the "Debug toolbar" (→ p. 249) for stepping:

Button	Description
	Step Over the next instruction: If the next instruction is a call of a function block or a sub-program, the execution passes over to the following instruction.
	Step Into the next instruction: <ul style="list-style-type: none"> • The next step is at the beginning of the called block. • If the next instruction is not a call of a function block or a sub-program, the Step Into behaves like the Step Over.
	Step Out the current block: <ul style="list-style-type: none"> • If the current stepping position is in a called function block or a sub-program, the execution continues up to the end of the current block. • Otherwise, the Step Out behaves like the Step Over.

These commands are available at any time:

Button	Description
	Execute a cycle step (from the current position up to the end of the last program).
	Restart the target in Normal execution mode (RUN).

4.13.2 Breakpoints

The step-by-step debugging feature is enabled by setting breakpoints in the source code of the application.

NOTE

This feature is only available when you have chosen the **DEBUG** mode. See [click here...](#) for more information.

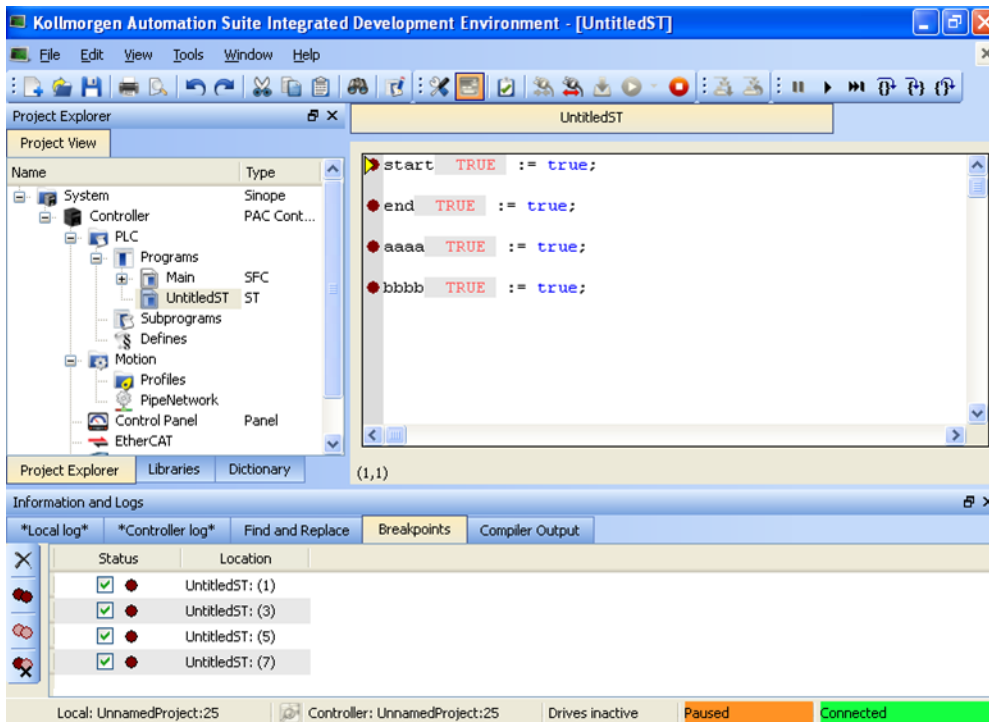

- Breakpoints are a marker that is set in code which, when reached, stops the code's execution at that location. This lets you run one step further in the program with stepping commands.

TIP

Pausing a program does not interrupt the current VM cycle.
The current cycle finishes and execution is paused before the beginning of the next VM cycle.

- Breakpoints are shown as a red circle (dark or light) in the left margin.
- Breakpoints may be active (●) or inactive (○).
- Breakpoints are active only when the IDE is connected to a target running an application that is compiled from the exact code displayed in the editor.
- Breakpoints are inactive if the IDE is:
 - not connected to a target.
 - connected but not running.
 - connected to a different version of the code.
 - connected to the code but a modification has been made in Edit mode.
- Breakpoints will always be applied to the target, based on their position in the editor. If a breakpoint is moved in the editor, then you reconnect to a target, the breakpoint in the target will be moved to the new position.
- A Breakpoint that has been "hit" has a yellow triangle (▶ and ▶) to indicate it has been reached in the code.
- Breakpoints are saved when saving the KAS application and are reloaded when loading a KAS application.
- See "Setting, Removing, Enabling, and Disabling Breakpoints" (→ p. 234) for information on working with breakpoints.
- See "Breakpoints tab" (→ p. 114) for information on the **Breakpoints** tab in the **Information and Logs** widget.
- Projects support a maximum of 16 breakpoints. This includes both enabled and disabled breakpoints.

NOTE

Breakpoints can significantly increase the PLC cycle time execution. This is due to the fact that the VM must evaluate the breakpoint condition at every cycle.

4.13.2.0.1 Online Change

- Online Change cannot be enabled when the KAS Runtime is paused due to a breakpoint.
 - Online Change can only be activated when the target is running.

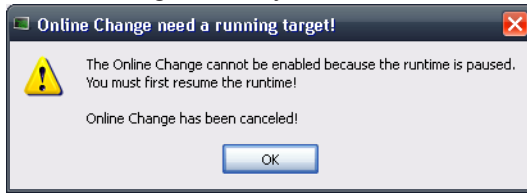

- Every breakpoint is activated if an Online Change is performed successfully.

NOTE

The breakpoints are not activated synchronously but in a reasonable time.

- All breakpoints become inactive when an Online Change is reverted.

4.13.3 Setting, Removing, Enabling, and Disabling Breakpoints

This section discusses working with breakpoints within the editor. See "Breakpoints tab" (→ p. 114) for information on the **Breakpoints** tab in the **Information and Logs** widget, including modifying breakpoints in bulk. For background information see "Breakpoints" (→ p. 232).

4.13.3.1 How to Set Breakpoints

1. Open your program in the IEC 61131-3 Editor.
2. Click on the line (for ST/ IL) or diagram (for SFC¹, FBD or FFLD) where you want to set the breakpoint.
3. Press **F9** or right-click and select **Add/Remove Breakpoint** from the menu.

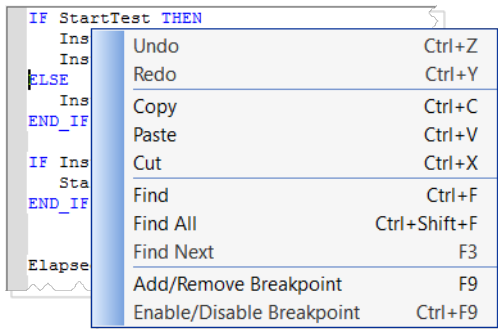

Figure 4-54: Setting Breakpoints

4. A Breakpoint circle is added to or removed from the left margin. The Breakpoint will be set as either active (●) or inactive (○), based on the IDE's connectivity (see "Breakpoints" (→ p. 232)).

Even when you are **not** connected to the Controller, breakpoints can be placed in programs, sub-programs or UDFBs.

NOTE

When you start your application, if the current position is not on a valid line for stepping, the breakpoint is automatically moved to the nearest valid position.

ⓘ IMPORTANT

When you close the connection with the target, all the breakpoints are removed in the KAS Runtime.

4.13.3.1.1 About SFC

There are several things to note about breakpoints in SFC programs:

¹See limitation explained in paragraph below: **About SFC**

- In **SFC** programs, breakpoints can only be set on transitions (i.e. in First Level diagram), and not in steps or conditions. With a breakpoint set on a transition, you can debug cycle-by-cycle. Please remember that P1, N and P0 placeholders are designed to contain very simple code.

TIP

The recommended way to proceed for SFC sub-level programs is to rely on subprograms, where debugging is allowed.

- Breakpoints can be set and removed in SFC programs, they cannot be enabled and disabled.

4.13.3.2 How to Enable/Disable a Breakpoint

To enable a breakpoint, right click on an inactive breakpoint and select **Enable / Disable Breakpoint** (or Ctrl + F9). This is only available when the IDE and runtime are connected.

To disable a breakpoint, right click on an active breakpoint and select **Enable / Disable Breakpoint** (or Ctrl + F9). Selecting this option will remove the breakpoint from the runtime; the breakpoint will remain in the editor and be changed to an inactive state (🔴).

4.13.4 Printf



Function - Used to display string in debug mode.

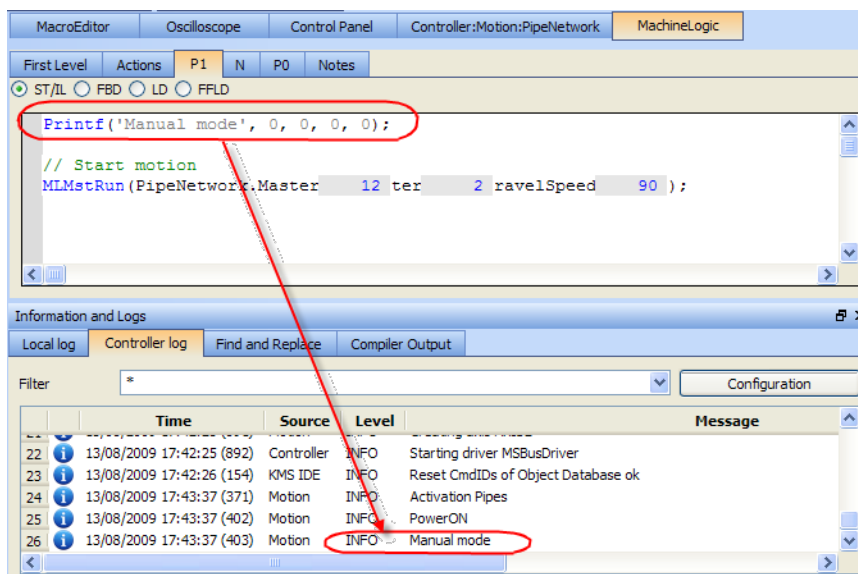

Figure 4-55: Printf

This is a good way to trace your SFC programs or use the `PrintMessage`.

4.13.4.1 Customize Output in the Log Window

Raise warnings or errors icons

First column in the log window has an information icon.

This can be replaced with a warning or error icon:

@W

@E

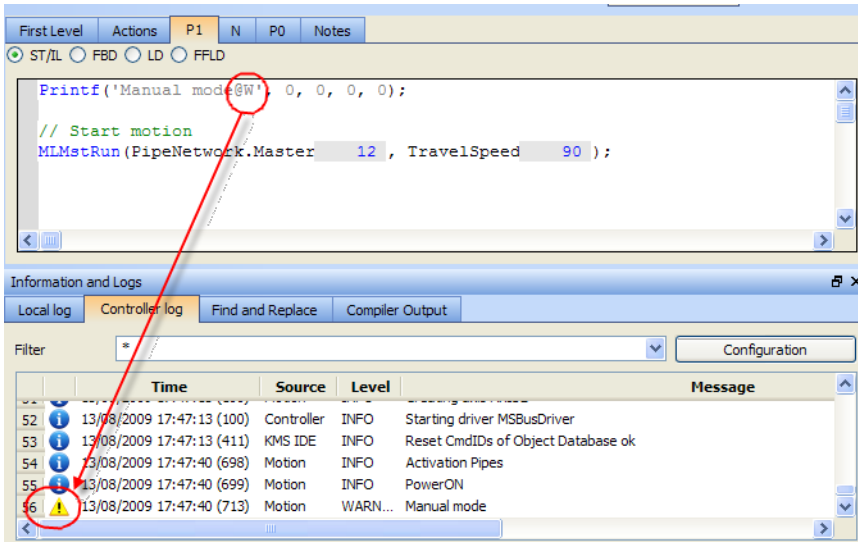

Figure 4-56: Customizing Output for Printf

4.13.5 Soft Oscilloscope Debugging

It can be interesting to access the values of the variables of the application. It is particularly important during development and debugging.

There is a way of visualizing and changing variables via the Graphics HMI panel (see "IEC 61131-3 Editor Debugging" (→ p. 243)). You can also access and change variables via the Variable Dictionary (see "Variable Monitoring" (→ p. 241)).

However, these two methods can only access and change variables from the PLC part and not from the Motion part of the application. Furthermore, the temporal evolution of the Motion variables would not be very intuitive. The ideal tool to trace the Motion variables is a softscope.

Other typical areas for using the softscope are:

- Recording when an input is sensed in a cycle
- Recording how much correction is being made in each cycle
- Checking the settling time of an axis

To open the Softscope, click the **Oscilloscope** command in the Tools Menu.

For more details on Softscope description and usage, refer to "Soft Oscilloscope" (→ p. 484)

4.13.5.1 Plug Motion Variables

NOTE

The Softscope retrieves the variable values from the Motion Simulator. You can only plug objects which exist in the Motion Simulator. While the PLC variables exist all the time, the Motion objects are only created after the start of the application.

When your application is running, do the following:

1. Open the **PipeNetwork** of your Controller in the Workspace
2. Right-click on Gear1 to open its menu

3. Choose the command **Plug on channel...**

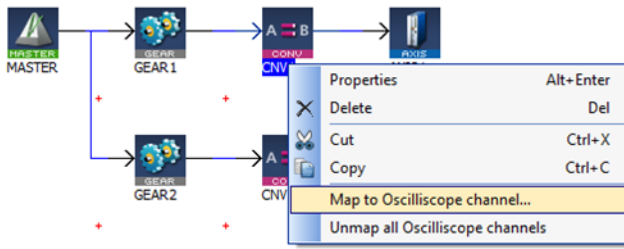

Figure 4-57: Plugging a Motion Variable

NOTE

Your application **must be connected and running** to plug a variable to the channel.

4. Set Channel to **1** and choose the relevant Data

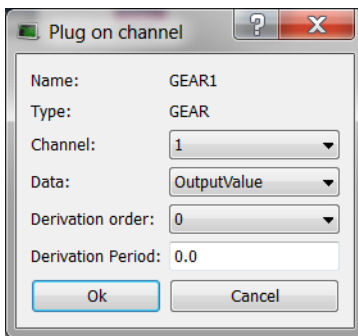

Figure 4-58: Plugging a Motion Variable - Parameters

NOTE

The complete list of data are only visible when your application is running

For more details on the parameters, refer to (→ # 492, Plugging Probes, Mapping Variables)

4.13.5.1.1 Usage example with the Pipe Network

The Softscope allows the recording and display of motion at points any where in a Pipe Network.

The following example shows the difference between the input and output of the Phaser Pipe Block (called AngleAdvance).

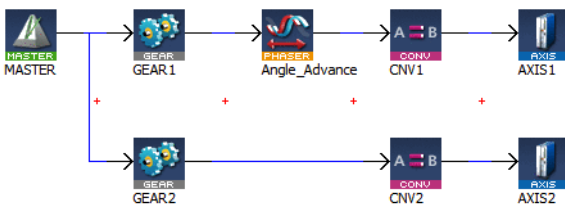

The red line is the input, the green line is the output and the blue line shows when the phase advance change was active.

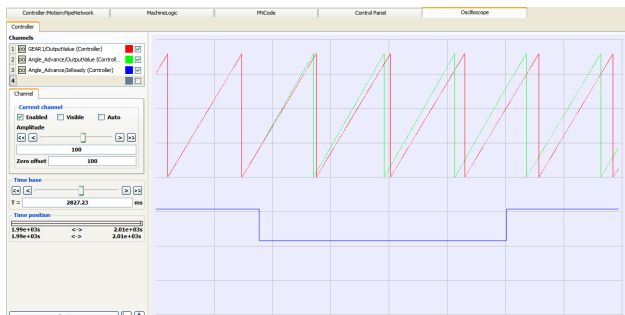

Figure 4-59: Example of Plugging a Pipe Block
 also see "Plug PLC Variables" on page 238

4.13.5.2 Plug PLC Variables

1. In the Variable Dictionary, right-click on the variable **lastMachineSpeed** to open its menu
2. Choose the command **Plug on channel**

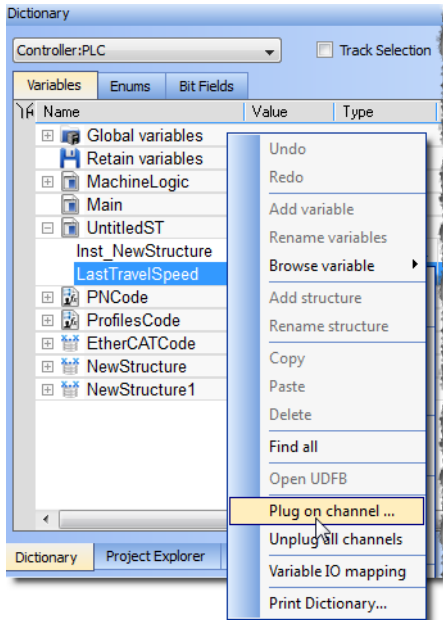

Figure 4-60: Plugging a PLC Variable

3. Set Channel to **2**(because channel 1 is already plugged)

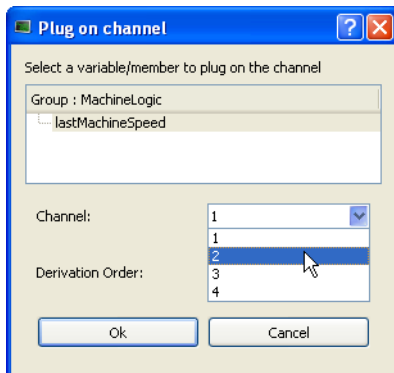

Figure 4-61: Plugging a PLC Variable - Parameters

You can start the Softscope now to see traces, as shown in the following figure:



Figure 4-62: Traces Displayed with Soft Oscilloscope

TIP

Easy probe plugging is assured since you do not need to unplug a probe from a channel before plugging a new probe into the same channel.

also see "Plug Motion Variables" on page 236

4.13.6 Compare PLC Programs

KAS provides a tool to show the differences between the Local Project and the project currently on the Controller or another project file.

TIP

- To compare project files, use the [Compare Projects](#) function from the File menu.
- The function for comparing the local project file to that on the controller is accessed from a button on the [Status Bar](#), between the Local and Controller versions. It is active when KAS is connected to a controller.

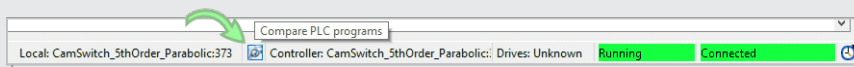

Once files have been selected to compare, a window opens listing the components of each project and any differences between them.

- How the projects differ is color coded.
 - Red** item indicates where there is a mismatch.
 - Double-click to open an item. The << button brings you back to the list.

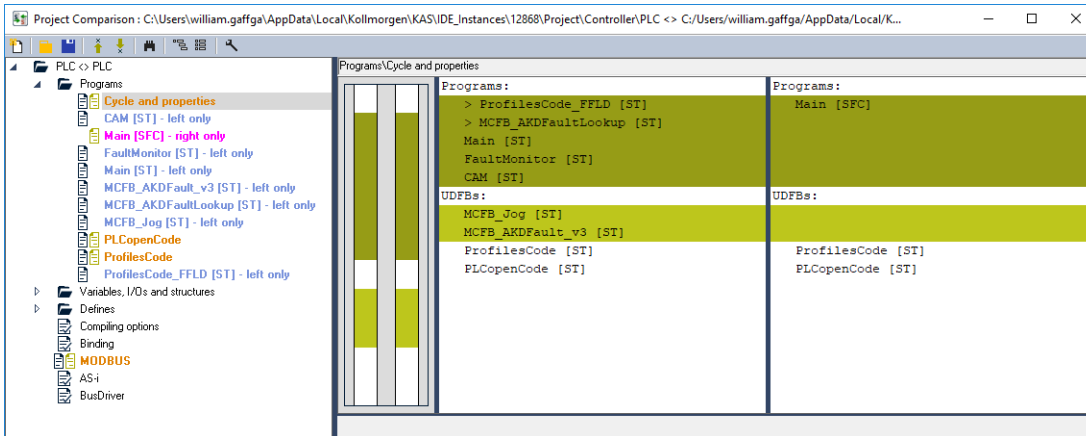
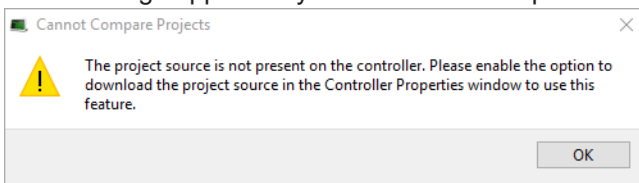

Figure 4-63: Listing the Differences

This message appears if you click on the compare button but the project is not present on the controller.



4.13.6.1 Limitations of FFLD Diagrams

If one or more components within a network differ, then the entire network is displayed in the diff view with a gray background.

Differences between individual components within the network are not specified in any way.

Example: This image has a comparison of two FFLD programs.

- Network #1 differs, but the actual difference is not called out or highlighted.
 - The difference is the last element: a coil on the left diagram and an inverted coil on the right diagram.
- Network #2 is the same on the left and right, so it has a white background.

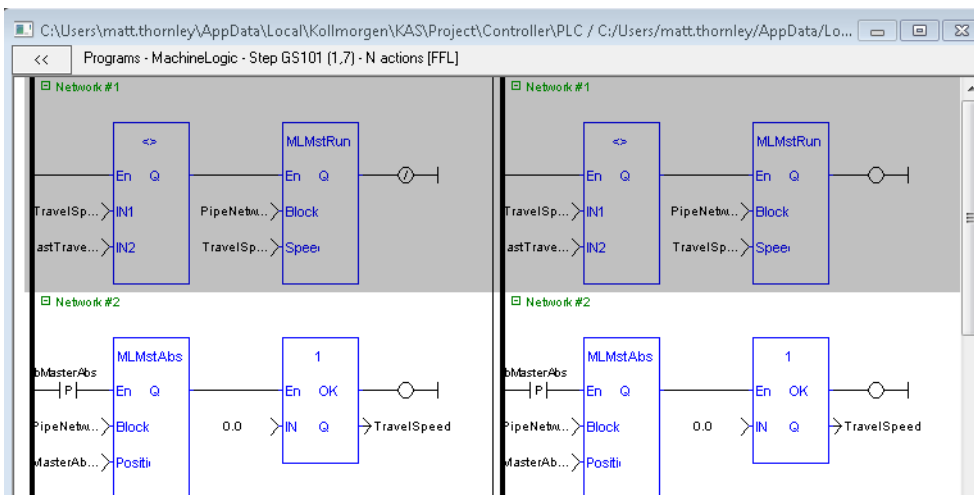

4.13.7 Variable Animation

When your application is running, all variables in the "IEC 61131-3 Editors" (→ p. 269), in the [Dictionary](#) and in the [Watch Window](#) are animated. This means the value of each variable is displayed dynamically.

NOTE

When the value of a variable is displayed, only the value computed at the end of the cycle is displayed. So if the same variable is set in different programs, the animation in all those programs displays the same value for the variable, which corresponds to the latest program executed within the cycle.

4.13.7.0.1 About Online Change

When [Online Change](#) is enabled, the animated values only take place when you are in [Debug](#) mode (and not edit).

4.13.7.0.2 Limitations

- The versions on the KAS-IDE and the KAS Runtime must be the same
- Animation does not apply to actions in an SFC step

4.13.7.1 Variable Monitoring

The Variable Dictionary contains all the IEC 61131-3 variables needed by the application. The variables are listed by categories corresponding to the declared programs, functions and function blocks.

When your application is running:

- all variables in the Dictionary are animated ¹ with real-time values displayed in the **Value** column (see call out **1**)
- a specific column is used to indicate the initial values of all variables **2**

Name	Value	Type	Dim.	Attrb.	Init value	User ...	KVE
Global variables							
TravelSpeed	0.0	LREAL			LREAL...		
MasterAbsPos	0.0	LREAL			LREAL...		
MasterDeltaPos	90.0	LREAL			LREAL...		
MachineSpeed	0.0	LREAL			LREAL...		
Axis1Status	185	DINT					
Axis2Status	185	DINT					
MachineState	0	DINT			0		
bMasterAbs	FALSE	BOOL			FALSE		
bMasterRel	FALSE	BOOL			FALSE		
bEStop	FALSE	BOOL			FALSE		
bLedStatus		BOOL	[0..3]				
Profiles		ProfilesCode					
EtherCAT		EtherCATCode		Read Only			
Sample_Inst		NewStructure					
Inst_NewStructure1		NewStructure1					
PipeNetwork		PNCCode					
Retain variables							

Figure 4-64: Variable Dictionary

4.13.7.1.1 Monitoring UDFBs

The real time values for UDFBs can be shown in the workspace while the program is running. Double clicking on a UDFB in the Project View's Subprograms list will open the UDFB in the workspace. You will first be presented

¹To better track variables and expressions of the PLC programs in Test mode, the KAS-IDE dynamically computes their value along with the program execution and display the result in gray boxes beside their usage in the instruction lines of the IEC 61131-3 editor.

with a list of the UDFB's instances if it is instantiated more than once or declared inside of a structure.

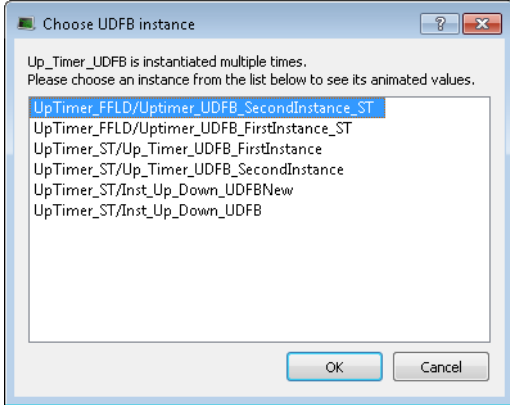

If the UDFB is open in the Workspace before running the program it will not automatically animate because there may be more than once instance of the UDFB. To start the animation double click the entry in the Project View. If there is only one instance, it will open; if there are multiple instances the list will be presented.

4.13.7.1.2 Forcing a Variable

At run-time, double-click on the value of the variable in the list or press the **ENTER** key when it is selected. A popup window appears and allows you to:

- **Force:** Change the value of the selected variable.
 - Depending on the variable type, you have the possibility to define its value either in the text field or with the check boxes.

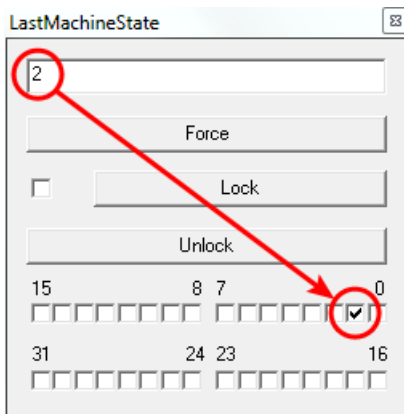
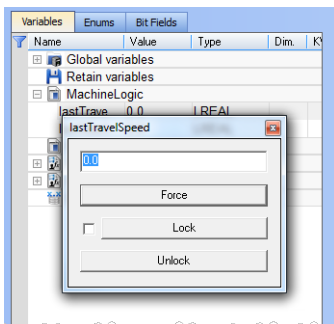
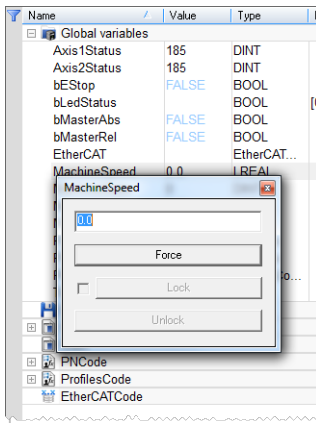

Figure 4-65: Forcing a Variable

The variable locking feature can be enabled or disabled via the PLC Options device toolbar button. If enabled, the Lock and Unlock buttons are accessible:



If disabled (default), the Lock and Unlock buttons are not accessible:



ⓘ IMPORTANT

If PLC variable locking is enabled, the controller Runtime requires an additional 3% to 10% CPU processing power to manage the PLC variable locking. For the best controller performance, disable PLC variable locking.

- **Lock:** When a variable is locked, its value is no longer changed by the runtime.
 - You can then force its value from the debugger, independently from the runtime operations.
 - All variables can be locked and forced at run-time.

👉 TIP

The value of a locked variable is displayed with square brackets.

```
ActualMachineState [[ -1 ]] := -1;
```

- **Unlock:** Remove the lock on a variable so it can be changed again by the runtime.

4.13.7.2 IEC 61131-3 Editor Debugging

In Test mode (Online or Simulation), all editors are animated ¹ with real-time values of the edited objects:

- Values of variables, contacts and coils are displayed in FBD diagrams.
 - Double-click a variable name to force or lock the variable.
- Values of variables, contacts and coils are displayed in FFLD diagrams.
 - Double-click a variable name to force or lock the variable.
- Step activities (tokens) are displayed in the SFC editor.
- In the text (ST or IL) editor, place the mouse cursor on a variable name to display its real-time value in a tooltip.
 - Double-click the variable name with the **Shift** key pressed to force or lock the variable.

```
Repeat
MyCounter (TRUE, FALSE, 16#FFFF);
// CV := MyCounter.CV;
if MyCounter.CV.7 FALSE then
bToggleVal TRUE := TRUE;
Ledlight2 TRUE := bToggleVal TRUE ;
End_if;
bToggleVal TRUE := not bToggleVal TRUE ;
Ledlight2 TRUE := bToggleVal TRUE ;
Until MyCounter.Q FALSE = FALSE
end_repeat;
```

Figure 4-66: Animation in Editors

See also "Forcing a Variable" (→ p. 242) for more information.

¹To better track variables and expressions of the PLC programs in Test mode, the KAS-IDE dynamically computes their value along with the program execution and display the result in gray boxes beside their usage in the instruction lines of the IEC 61131-3 editor.

4.13.7.3 Pipe Network Editor Debugging

See "Plug Motion Variables" (→ p. 236).

4.14 Managing a Project

The **New** command in the File menu uses a wizard to help you to define the project.

The **Open...** command opens a window to let you navigate your system and retrieve previous projects.

The **Save** command saves your entire project.

The **Save As...** command allows you to save your project with a custom name and location.

NOTE

Choose a safe folder for your project. Never select the Installation repository.

The **Close** command prompts you to save first if some modifications have not been saved.

NOTE

When a project is already open, and you try to create or open another one, the KAS-IDE proposes you to save your project before it is closed.

The **Print...** command allows you to create documentation containing editors' programs or diagrams.

For more details on the File menu, also refer to "Menus and Toolbar Overview" (→ p. 249).

TIP

With the **Recent Projects** command in the File menu, the last four projects can be opened easily.

When editing your project, the KAS-IDE has the following restrictions:

- You cannot work with several projects in parallel. You may use multiple instances of the KAS-IDE as a work-around.
- Modifications that impact the project structure cannot be reversed with the **Undo** command (you have to make a backup first using the **Save As** command)
- No guarantee is provided by the KAS-IDE with respect to the project file's integrity (this means that if you modify your data from outside the KAS-IDE, you can spoiled your project)

Use a Version Control System

To ensure integrity of your project files, you have to rely on tools to control versions.

Generally, such tools also have facilities for:

- Backup management
- Multi-users or multi-site development

4.14.1 Print

4.14.1.1 Printable Elements

The elements that you can print are:

- All PLC programs (see [PLC](#) node in the Project Explorer)
- Individual programs
- Level 2 SFC
- Level 2 SFC of single transition/state
- The Pipe Network editor
- The Dictionary

You can either print [one specific](#) program or [all the project](#) (PLC, Motion, Dictionary variables)

4.14.1.2 Page Setup

This dialog enables you to define the following settings:

Page Setup tab

- **Orientation:**
Allows you to choose between portrait or landscape.
Because the orientation can be set in both the page setup and the printer driver, it is recommended to have both settings synchronized.
- **Scaling:**
You can select the **Fit to** option to fit on the specified number of pages. You have to enter one of the two values (either Wide or Tall) and the other are filled in automatically to keep a 1:1 aspect ratio of the print.

NOTE

These settings are not applicable when printing a [project](#).

Margin and Header/Footer tab

If you specify new margins or header/footer for a program, it affects the entire project when printed.

About field items used in Header/Footer

Special items can be inserted into the header/footer string as **{@item}**. They are converted to the correct format on printing or for print preview.

About the **Filename** field:

If an SFC level 2 program is being printed, the filename contains the SFC program name, Step or Transition number and the action tab name (e.g. Main, GS3, P1).

NOTE

All the settings defined in the Page Setup are saved within your project and are applied to each printed program.

This dialog box also contains two buttons:

- **Print...** displays the Printer dialog box as described below
- **Print Preview** displays a printout on the screen so you can see how it looks like before printing it.

4.14.1.3 Print

This dialog enables you to:

- Set the output (a printer, a PDF)
- Set the output preferences to set-up the printer options
- Look for a printer on the network
- Set the number of copies
- Set the page area to be printed
- Start the print

To print an SFC level 2 program, open it in the SFC editor and click the Print icon  (Ctrl + P)

4.14.1.4 Print Preview

This dialog box enables you to display a printout on the screen so you can see how it looks before printing.

NOTE

Print preview limits the number of pages to display to the first 30 pages.

4.14.1.5 Print Project

A Print Project dialog displays all the items that are printable. Then you can select those you want to include in your output and click **OK**.

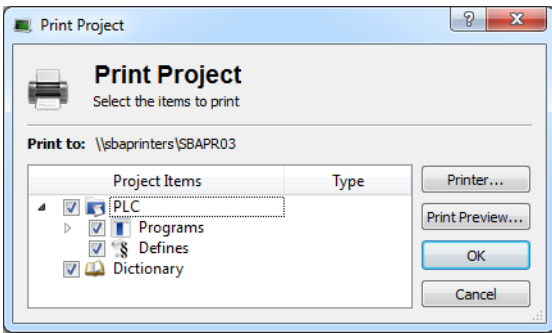

Figure 4-67: Print Project

NOTE

Selecting an SFC program prints the SFC chart as well as SFC level 2 programs. Automatic scaling is applied for best readability.

4.14.2 Use the Reference Folder

Using the Reference item, you can link as many files as you want to your project.

1. Right-click on the Reference item and select the **Insert Reference** command

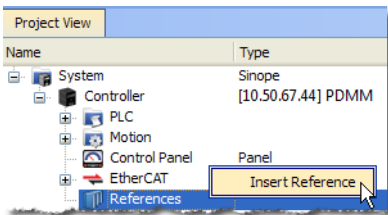

Figure 4-68: Inserting a Reference

2. Define the **Name** and choose a valid **URL**

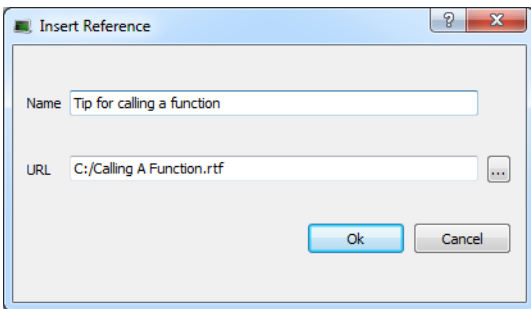

Figure 4-69: Defining the Reference

3. You can double-click the new reference to open it in the workspace

NOTE

You can link files that are on your local machine (or to a server shared with a mapped drive) and of the following types: pdf, doc, xls, drawings, etc.. You must ensure the link is not broken if you want the KAS-IDE to open it correctly.

5 KAS IDE Reference

This section provides in-depth reference to using elements of the KAS-IDE interface.

5.1 Choose a Workspace Layout

5.1.1 Move Child Windows

In the integrated workspace, all child windows are integrated into a single larger [application window](#).

With the MDI/Tabbed workspace command in the Window menu, you can choose to display the child windows either as Tabbed Document Interface (TDI) or as Multiple Document Interface (MDI).

When in MDI mode, you can move and resize the displayed windows.

The Cascade command automatically rearranges all the windows to provide you with easier access to each of them.

5.1.2 Move Toolbox

All toolboxes can be moved within the workspace to a more appropriate location.

- To customize your workspace, click in the Toolbox header and move the window using drag-and-drop.
- The other toolboxes are adapted accordingly.

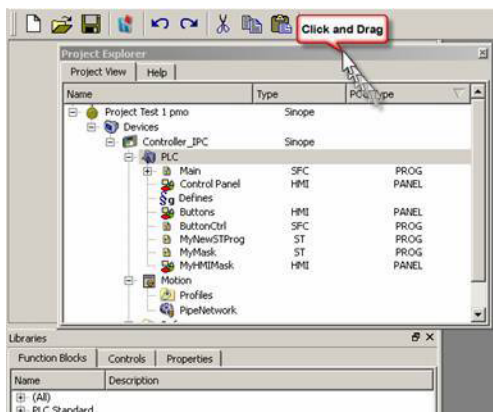

Figure 5-1: Moving Toolboxes

5.1.3 Dock Window

You can separate out a toolbox and change it to a docking window to be placed in the workspace independently of the other toolboxes.

[How to change a toolbox to a Docking window?](#)

To do so, click the  icon (you can also double-click in the toolbox header).

TIP

Double-click to place the window back into its original position.

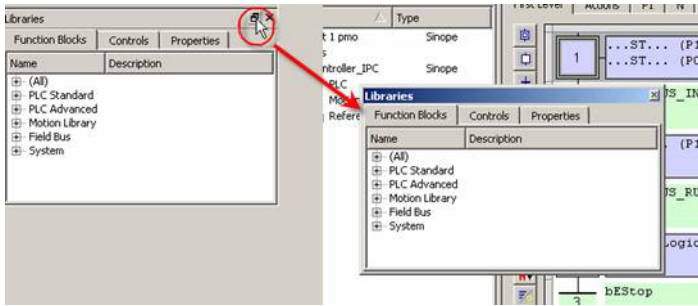

Figure 5-2: Docking window

NOTE

Moving a toolbox to a docking window can lead to problems which can be difficult to recover.

How to undock a window?

If problems arise, drag-and-drop the window to a toolbox border as shown below:

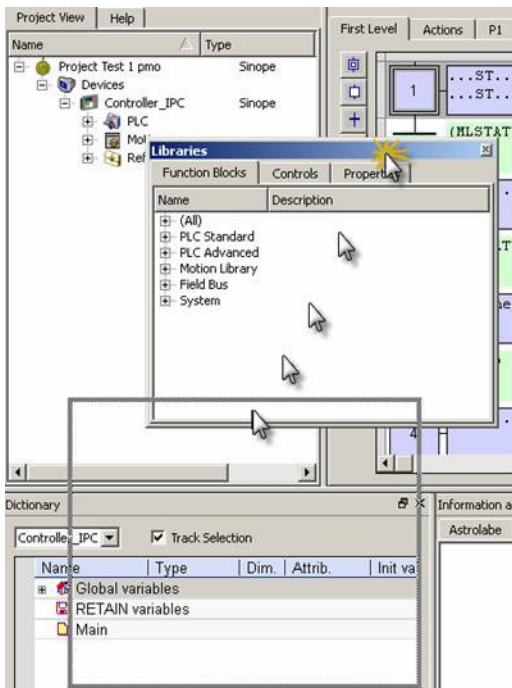

Figure 5-3: Undock window

Dropped in the bottom border of the Project Explorer toolbox, then the **Libraries** toolbox is moved nearby.

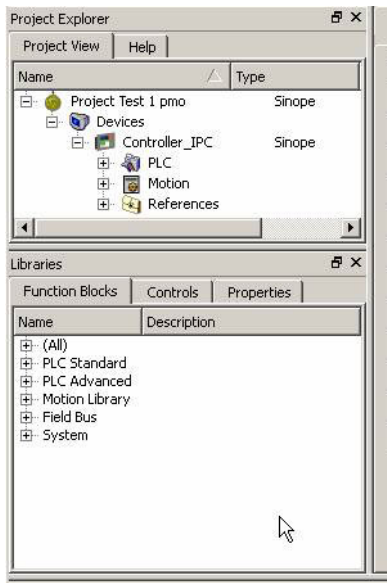

Figure 5-4: Undocked window completed

5.2 Menus and Toolbar Overview

5.2.1 Menus

The KAS-IDE contains these menus:

- "File menu" (→ p. 251)
- "Edit menu" (→ p. 254)
- "Tools menu" (→ p. 256)
- "Window menu" (→ p. 258)
- "Help menu" (→ p. 255)

5.2.2 Toolbars

These are the KAS-IDE toolbars:

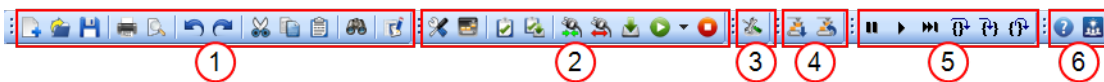

1. "Main Toolbar" (→ p. 255)
2. "Device Toolbar" (→ p. 250)
3. "EtherCAT Toolbar" (→ p. 255)
4. "Online Change Toolbar" (→ p. 256)
5. "Debug toolbar" (→ p. 249)
6. Links to the **Help** and [Kollmorgen Developer Network \(KDN\)](#).







A specific toolbar is also available for the "AKD Drive" (→ p. 122).

For details about icons available in the graphical PLC editors, see these sections:

- [FBD toolbar](#)
- [FFLD toolbar](#)
- [SFC toolbar](#)

5.2.3 Debug toolbar



This table describes each **Debug** toolbar button.





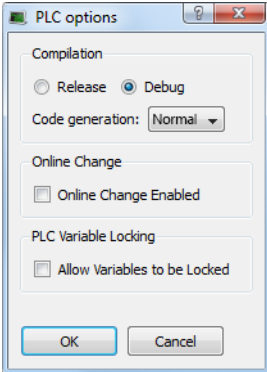

Button	Description
	Pause the application in Cycle to Cycle mode.
	Restart the target in Normal execution mode (RUN).
	Execute a cycle step (from the current position up to the end of the last program).
	Step Over the next instruction: If the next instruction is a call of a function block or a sub-program, the execution passes over to the following instruction.
	Step Into the next instruction: <ul style="list-style-type: none"> The next step is at the beginning of the called block. If the next instruction is not a call of a function block or a sub-program, the Step Into behaves like the Step Over.
	Step Out the current block: <ul style="list-style-type: none"> If the current stepping position is in a called function block or a sub-program, the execution continues up to the end of the current block. Otherwise, the Step Out behaves like the Step Over.

5.2.4 Device Toolbar

This table is a list of each toolbar icon and a description of its functionality.

Each icon provided in this toolbox has a brief explanation provided below in order to explain the functionality.

Icon	Description
	<p>Show the PLC options dialog.</p>  <p>The dialog has Compilation parameters that can be modified for the target.</p> <ul style="list-style-type: none"> See "Set the Compilation Options" (→ p. 222). The Online Change frame is used to allow or forbid Online Changes. <ul style="list-style-type: none"> See "PLC Online Change" (→ p. 555). The PLC Variable Locking frame is used to allow or forbid PLC variables to be locked (forced). <ul style="list-style-type: none"> See "Forcing a Variable" (→ p. 242). The PLC options selections are stored in a KAS project file and are loaded when the project is opened.
	<p>Change the Controller IP address to connect with KAS Simulator. See (→ # 361, Using the KAS Simulator).</p>

Icon	Description
	Compile the project.
	Compile and download the project.
	Establish a connection with the target Controller. For possible statuses, see the "Color Codes" (→ p. 125) table for the labels of the status bar.
	Close connection with the target Controller.
	Download the application to the targeted Controller (Note that the application must not be running). See (→ # 228, Download the Project).
	Start the application. It can be either a Warm or Cold start.
	Stop the application.

NOTE

The **Allow Variables to be Locked** option cannot be changed while the **Online Change Enabled** option is selected.

If Online Change is enabled, deselect the Online Change Enable option first, enable or disable PLC Variable Locking, then re-enable Online Change, and re-compile the project.

5.2.5 File menu

Command	Description
New (Ctrl+N)	Close the current project if any, and then launch the project wizard to create a new one.

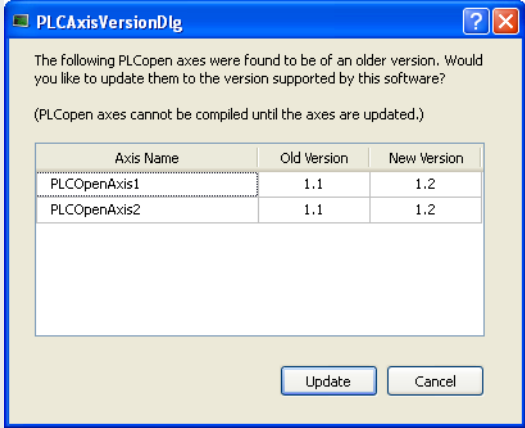
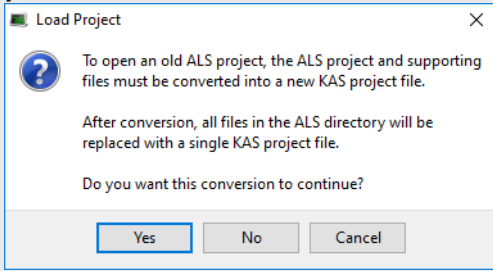
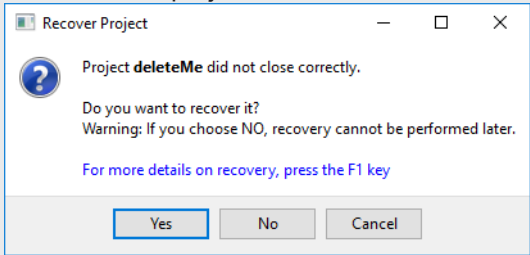
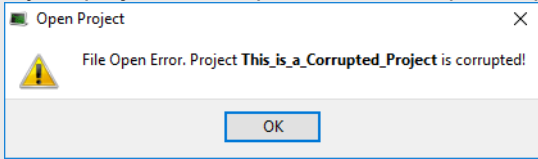
Command	Description
Open... (Ctrl+O)	<p>Open an existing project.</p> <p>Projects from an older version When you try to open a previous project, KAS-IDE proposes you to do the conversion to keep the compatibility.</p>  <p>ALS project When you try to open a previous project with ALS format, the KAS-IDE proposes you to convert it to the current KAS format.</p>  <p>After conversion, all the files located in the folder structure are replaced with a single KAS file.</p> <p>Auto Recovery If the KAS-IDE crashes when you are working with a project, you can start it again to recover the project from the last successful Save (or auto save) operation.</p>  <p>This file can be automatically saved periodically, so you recover recent work instead of the last manually saved file. See "User Options" (→ p. 257) from the "Tools menu" (→ p. 256).</p> <p>Corruption If your project is corrupted, KAS-IDE opens a pop-up window.</p>  <p>Or open an existing library.</p>

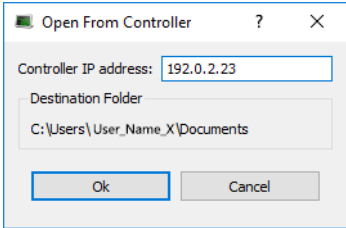
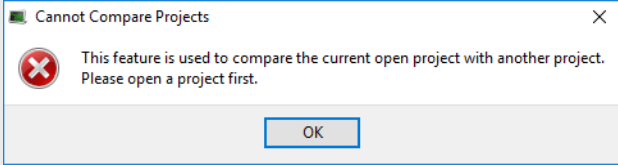
Command	Description
Open From Controller (Alt+Shift+O)	<p>Project files saved on a controller can be retrieved using this command. To retrieve the project, enter the controller's IP Address.</p>  <p>Successfully retrieved projects are saved in My Documents before being opened. See "Download the Project" (→ p. 228) for information on storing projects on the controller.</p>
Save	<p>Save the current project</p> <p>About Auto Save At compile time, an auto-save operation is performed to recover the project if a crash occurs.</p> <p>Saving when in Debug mode automatically switches the program to Edit mode.</p>
Save As...	<p>Save the current project in a location and with a name that you can define. The project name is also in the KAS-IDE window's title.</p>
Compare Projects (Alt+Shift+C)	<p>This option allows for comparison between an open project and another local project.</p> <ul style="list-style-type: none"> Once you have browsed for and selected the file for comparison, a window opens showing the differences between the files. See "Compare PLC Programs" (→ p. 239) for more information on the comparison tool. A project must be loaded in the IDE to use this function. <ul style="list-style-type: none"> If a project is not present, this error opens. 
Close Project	<p>Close the current project.</p> <p>If changes have not been saved, a prompt opens first.</p>

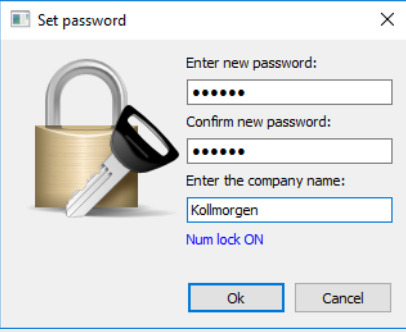
Command	Description
Password Protection	<p>This option provides the ability to set, change, and remove password protection on a project file to prevent unauthorized access.</p> <ul style="list-style-type: none"> The menu options are available when a project is open. Passwords must be 6-20 characters in length. <ul style="list-style-type: none"> They may consist of any alpha-numeric characters (a-z, 0-9, \$, &, *, }, etc.). Spaces, tabs, and apostrophes are not permitted. A company name must be provided; this should be the name of the company which owns the application source code.  <ul style="list-style-type: none"> The status bar has a project security status icon in the lower left corner: <ul style="list-style-type: none"> Protected (🔒) Unprotected (🔓) To protect a project, which is stored on the controller, the Project must be compiled and downloaded.
Page Setup...	Define page setup, margins and header/footer
Print...(Ctrl+P)	Print the project element currently open in the workspace
Print Preview...	Display a printout on the screen so you can preview it before printing
Print Project...	Select among the complete project's elements those you want to print
Recent Projects	List the most recently used projects
Exit	Quit KAS-IDE

5.2.6 Edit menu

Command	Description
Cut	Cut selected data and copy it to the clipboard.
Copy	Copy selected data to the clipboard.
Paste	Paste the data currently stored in the clipboard.
Undo	Undo the last command.
NOTE	
This action is not possible for all operations.	
Redo	Redo the last command.
Find...	Show the Find and Replace tab in the "Information and Logs window" (→ p. 102) toolbox.

🔗 TIP

See "Can I copy and paste or drag and drop between instances of the KAS-IDE" (→ p. 825) for more information on the copy/paste functions, including drag-and-drop.

NOTE

Closing the KAS-IDE automatically clears the Clipboard.
 Anything that was copied is cleared from memory.
 This means you can not copy something, close the KAS-IDE, and then paste.

5.2.7 EtherCAT Toolbar

Each icon in this toolbox has a brief explanation provided below in order to explain the functionality.

EtherCAT Toolbar Icons

Icon	Name	Description
	Online Configuration Mode	<p>This action is only available when the KAS Runtime is connected with the target Controller.</p> <ul style="list-style-type: none"> Click this toggle button to change the mode (ON / OFF). After the scan has been performed, and your project is compliant with the physical devices on the EtherCAT network, you can activate the Online Configuration Mode. <ul style="list-style-type: none"> Online Configuration Mode allows setting up AKD and AKD2G drives in an EtherCAT installation. In this mode, KAS-IDE communicates with the drives through the integrated views of the AKD Setup Screens or with the AKD Setup Wizard. KAS-IDE displays a quick status overview of all the drives. The AKD Setup Screens allow functions (e.g., enabling / disabling the drive, service motion, tuning, and a scope) where you can plot up to six different parameters from the drive. <ul style="list-style-type: none"> See click here... for more information. See "FAQs" (→ p. 823) for a potential issue when resetting the factory parameters.













5.2.8 Help menu

Command	Description
Documentation	Opens the help system.
Help Preference	<p>As stated in Is the Help System Online or Offline?, there is more than one type of help system with different advantages.</p> <p>By default the Online version is used.</p> <p>If you prefer, you may specify which Help version to use, the Online (default) or Offline (built-in) help system.</p>
Kollmorgen Developer Network (KDN)	Opens a web browser to the Kollmorgen Developer Network (www.kollmorgen.com/developer-network/), a community support site.
About	Shows version numbers and other information about the KAS-IDE. See also see "Find the KAS-IDE Version" on page 130.

5.2.9 Main Toolbar

The main toolbar of the KAS-IDE (Tools) contains these icons:



Main Toolbar Icons

Icon	Description
	Create a new project
	Open an existing project
	Save the project
	Print the project item currently open in the workspace See (→ # 244, Print) for more information.
	Print preview
	Undo
	Redo
	Cut
	Copy
	Paste
	Find
	Toggle Edit/Debug mode (enabled when the application is running). See (→ # 555, PLC Online Change) for more information

5.2.10 Online Change Toolbar

Each icon provided in this toolbox has a brief explanation provided below to explain the functionality.

Debug Toolbar Icons

Icon	Description
	When Online Change has been activated in the PLC options; the new code is loaded even if the application is running. See the Warning in (→ # 557, Activate an Online Change).
	Revert the changes made after an Online Change and return to the previous application.

5.2.11 Tools menu

Command	Description
Oscilloscope	Show the "Soft Oscilloscope" (→ p. 484).
Compile (Ctrl + B)	Compile the whole project.
Compile & Download (Ctrl + F7)	Compile the whole project and download it to the controller.

Command	Description
User Options	Open the "User Options" (→ p. 257) dialog box.

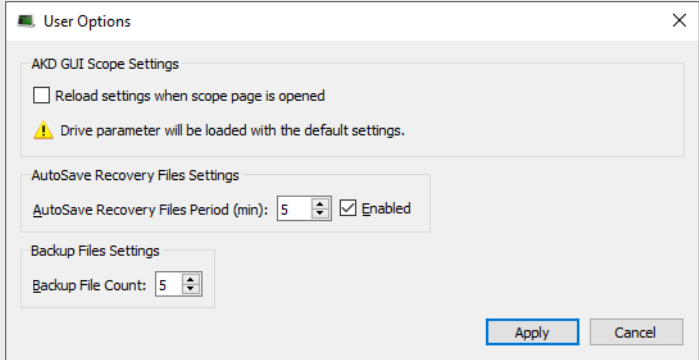

5.2.11.1 User Options

5.2.11.1.1 AKD GUI Scope Settings

The check box found in this dialog enables/disables the **Load at startup** option in the AKD GUI Scope Settings tab.

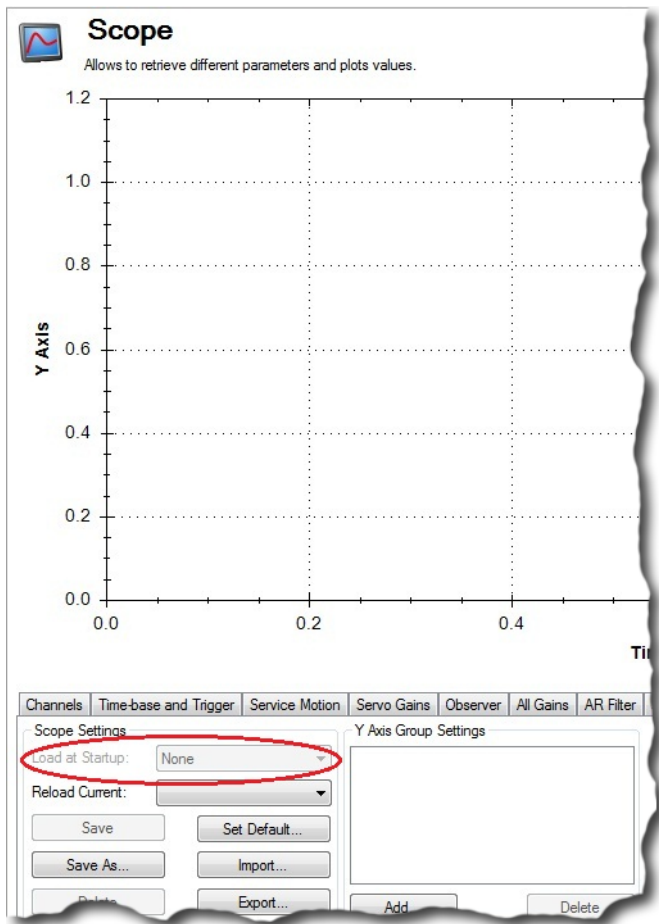

5.2.11.1.2 AutoSave Recovery File Settings

This option enables / disables automatically saving project recovery files at a specified interval.

- Once set, this applies to all further project recovery files for the user.
- The stopwatch icon in the bottom right corner of the KAS-IDE indicates whether AutoSave Recovery Files is active (

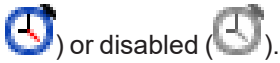

- See "How does file recovery work?" (→ p. 826) for information about recovery files.

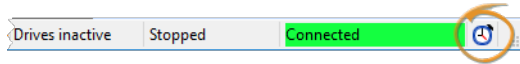

5.2.11.1.3 Backup File Settings

This option configures the automatic backup of KAS project or library files when the project or library is saved.

- The maximum number of backups is specified by the "Backup File Count" spinbox.
- Backup files are stored in the same directory as the KAS project or library that is being saved.
 - Backup files have the extension `.backup[nn].kas` or `.backup[nn].kal` where `[nn]` represents two digits.
 - The most recent backup of a KAS project is `.backup01.kas`; the next most recent backup is `.backup02.kas`, and so on.

5.2.12 Window menu

Command	Shortcut	Description
MDI/Tabbed Workspace	Ctrl+W	Toggle the workspace between the MDI and the tabbed mode.
Cascade	Alt+C	Re-arrange all workspace children windows in cascade mode.

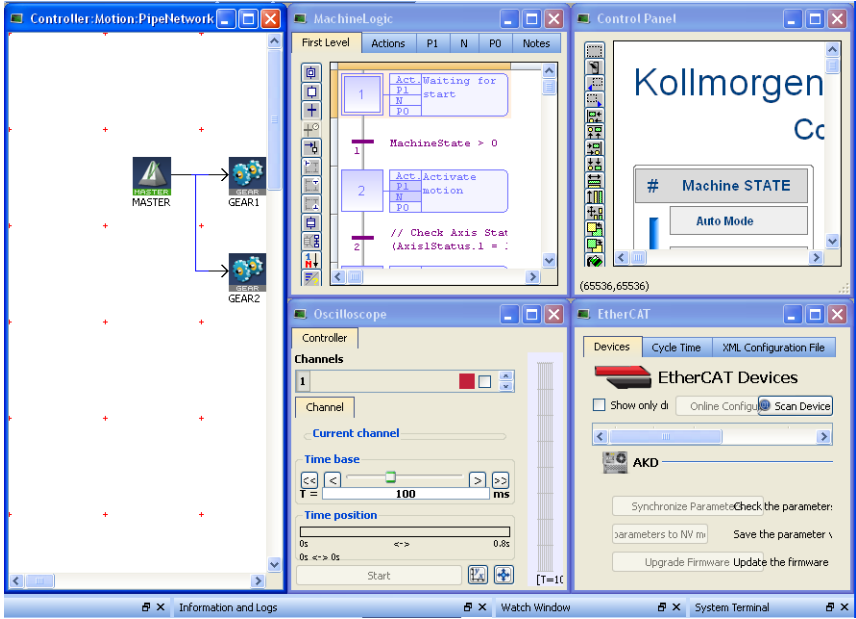
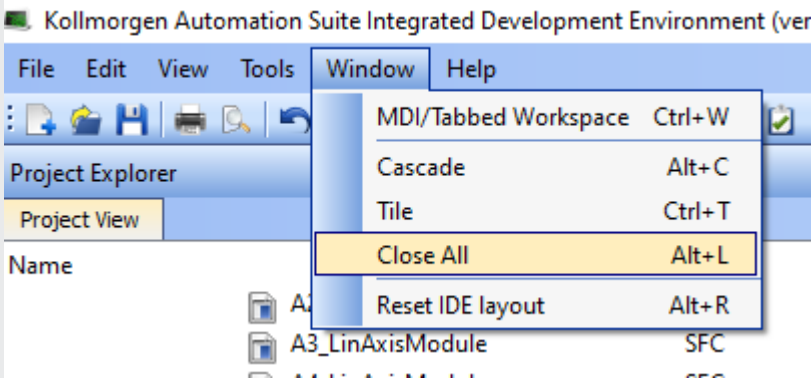
Command	Shortcut	Description
Tile	Alt+T	Re-arrange all workspace children windows in tile mode.
		
Close All	Alt+L	
Reset IDE Layout	Alt+R	<p>This option resets widgets to their default location and visibility. If an item is hidden or floating, it is made visible and returned to its default position.</p> <p>These interface items are affected by this option:</p> <ul style="list-style-type: none"> • "Project Explorer" (→ p. 71) • "Libraries" (→ p. 85) • "Dictionary" (→ p. 86) • "Information and Logs window" (→ p. 102) • "Watch Window" (→ p. 117) • "Toolbars" (→ p. 249)

5.3 Windows Standard Conventions

5.3.1 Windows Manipulation

The following standards apply to the KAS-IDE windows:

- Move
- Resize
- Minimize

- Maximize
- Close (Alt+F4)

Press **Esc** to exit a pop-up window.

5.3.2 Mouse Manipulation

Double-click an item to open it (e.g. double-click a program in the Project Explorer to open it in the appropriate editor)

Right-click to open the menu and give access to the relevant commands (e.g. to add a variable to the Dictionary)

5.3.3 Table Manipulation

5.3.3.1 Sorting Items

If the sort feature is implemented, you can click in the column header to sort all the items according to one of the available parameters.

Click again to alternately sort in ascending or descending order.

5.3.3.2 Selecting a Cell

Click a cell in the table to select it. Once selected, press **F2** to edit the value.

Name	Type	Dim.	Attrib.
NewVar	BOOL		
MachineLogic		2,10,4	

TIP

A double-click directly opens the pop-up window for editing.

5.3.3.3 Selecting a Row

When available, press the **Spacebar** to toggle the selection mode from cell to row. Then click a cell in the table to select the entire row. Once selected, press **F2** to edit the values of the row.

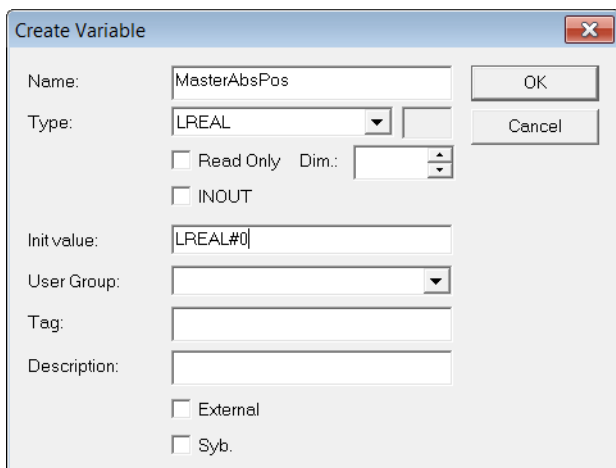

5.3.3.4 Resizing a Column

If you want to enlarge a column width to make more content visible, put the mouse in the table header between

two columns so the cursor change to the following  and move right or left to resize your column. After this operation, you need to scroll horizontally to see the other columns.

5.4 Keyboard Shortcuts

List of accelerator keys sorted by context:

- "Common Keyboard Shortcuts" (→ p. 261)
- "FBD Editor Keyboard Shortcuts" (→ p. 262)
- "FFLD Editor Keyboard Shortcuts" (→ p. 263)
- "SFC Editor Keyboard Shortcuts" (→ p. 267)
- "ST Editor Keyboard Shortcuts" (→ p. 268)
- "Graphic Editor Keyboard Shortcuts" (→ p. 266)
- "Table Keyboard Shortcuts" (→ p. 268)
- [CAM Editor](#)

NOTE

A shortcut can be unavailable depending on the context.

5.4.1 Common Keyboard Shortcuts

List of Common Keyboard Shortcuts

Shortcut	Command
F1	Display the help
-	Collapse
+	Expand
Del	Delete
Ctrl + B	Compile the project
Ctrl + F7	Compile and Download the project
Ctrl + C	Copy
Ctrl + F	"Find and Replace tab" (→ p. 108)
Ctrl + Shift + F	Find All
Ctrl + N	New
Ctrl + O	Open
Ctrl + P	"Print" (→ p. 244)
Ctrl + S	Save
Ctrl + V	Paste
Ctrl + X	Cut
Ctrl + Y	Redo
Ctrl + Z	Undo
Alt + Shift + O	Open from controller
Alt + Shift + C	Compare projects
Page Up/Down	Scroll Page up/down
RETURN	Equivalent to double-click

TIP

See "Can I copy and paste or drag and drop between instances of the KAS-IDE" (→ p. 825) for more information on the copy/paste functions, including drag-and-drop.

NOTE

Closing the KAS-IDE automatically clears the Clipboard.
 Anything that was copied is cleared from memory.
 This means you can not copy something, close the KAS-IDE, and then paste.

5.4.2 FBD Editor Keyboard Shortcuts

- "FBD Editor (common)" (→ p. 262)
- "FBD Editor (when editing)" (→ p. 262)
- "FBD Editor (during debug)" (→ p. 262)

5.4.2.1 FBD Editor (common)

List of FBD Shortcuts

Shortcut	Command
Arrows	Scroll window
Ctrl + d	Display FBD execution order
Ctrl + page UP/DOWN	Go to previous/next section
Ctrl + mouse-wheel or + / - on the keypad	Zoom in / out
Escape	Cancel linking/resizing/dragging. If selection: Deselect If no selection: Select mode active
Page UP/DOWN	Scroll page up/down
Return	Equivalent to double-click
Ctrl + Shift + End	Select all items from the cursor position to the end of the document
Ctrl + Shift + Home	Select all items from the begin to the cursor position
Tab	Select next position item
Tab + shift	Select previous position item
Ctrl+F2	Toggle Bookmark First, select the Network header)
Shift+F2	Go to Next Bookmark
Ctrl+Shift+F2	Go to Previous Bookmark

5.4.2.2 FBD Editor (when editing)

Shortcut	Command
char	Start editing a symbol (e.g., variable, constant, instance). On jump/comment/break: open dialog box to enter text.
Ctrl + arrows	Align selected items
Del	Delete selection
Shift + arrows	Move selection
Shift + page UP/DOWN	Move selection (4 cells)
Spacebar	Swap item style
Ctrl + Shift + down	Insert blank lines at the position of the mouse.

5.4.2.3 FBD Editor (during debug)

Shortcut	Command
Spacebar	Swap TRUE/FALSE Boolean value
*	Lock var
/	Unlock var

5.4.3 FFLD Editor Keyboard Shortcuts

- "FFLD Editor (when editing)" (→ p. 263)
- "FFLD Editor (during debug)" (→ p. 266)

5.4.3.1 FFLD Editor (when editing)

List of accelerator keys (sorted by action types).

5.4.3.1.1 Insert

List of FFLD Shortcuts

Shortcut	Command
Ctrl+Shift+D	Insert Coil De-Energize
Ctrl+Shift+E	Insert Coil Energize
Ctrl+Shift+R	Insert Coil Reset (Unlatch)
Ctrl+Shift+S	Insert Coil Set (Latch)
Ctrl+Shift+K	Insert a positive coil to the destination cell
Ctrl+Shift+L	Insert a negative coil to the destination cell
Ctrl+Shift+C	Insert Contact NC
Ctrl+Shift+A	Insert Contact NC, Negative Transition
Ctrl+Shift+I	Insert Contact NC, Positive Transition
Ctrl+Shift+O	Insert Contact NO
Ctrl+Shift+N	Insert Contact NO, Negative Transition
Ctrl+Shift+P	Insert Contact NO, Positive Transition
Ctrl+Shift+M	Insert Data In
Ctrl+Shift+W	Insert Data In Inverted
Ctrl+Shift+Q	Insert Data Out
Ctrl+Shift+B	Insert Wire (both)
Ctrl+Shift+H	Insert Horizontal Wire
Ctrl+Shift+V	Insert Vertical Wire
Shift+C	Insert Comment
Shift+Insert	Insert Network
Ctrl+Shift+J	Insert Jump
Ctrl+Shift+T	Insert Return
Insert Key	Insert Row
F8	Insert FB

5.4.3.1.2 Trace

Shortcut	Command
Ctrl+J	Trace Horizontal Wire Left
Ctrl+K	Trace Horizontal Wire Right
Ctrl+M	Trace Vertical Wire Down
Ctrl+I	Trace Vertical Wire Up

5.4.3.1.3 Move

Shortcut	Command
Ctrl+End	Go to End of Network
Ctrl+End followed by Ctrl+End	Go to End of Ladder
Ctrl+Home or Home followed by Home	Go to Top of Network
Ctrl+Home followed by Ctrl+Home	Go to Top of Ladder
Ctrl+Page Up	Go to Previous Network
Ctrl+Page Down	Go to Next Network
Ctrl+Left Arrow or Home	Move focus to begin of row.
Ctrl+Right Arrow or End	Move focus to end of row.
Tab	Move focus cell right
Shift+Tab	Move focus cell left
Arrows	Move focus cell or scroll through ladder
Page up	Scroll 1 page up
Page Down	Scroll 1 page down

5.4.3.1.4 Select

Shortcut	Command
Shift+Arrow	Multiselect cells
Shift+left Arrow	Select current cell and one cell to left
Shift+right Arrow	Select current cell and one cell to right
Ctrl+Shift+ right Arrow or Shift+End	Select from current cell to end of line
Ctrl+Shift+ End	Select from current cell to end of network. Bottom element of network and the furthest to the right.
Ctrl+Shift+ left Arrow or Shift+Home	Select from current cell to beginning of line
Ctrl+Shift+ Home	Select from current cell to beginning of network
Shift+up Arrow	Select Cell above or below when focus is on cell.
Shift+down Arrow	Select Row above or below when focus is on left rail
Ctrl+A	Select the contents of a network/rung
Ctrl+A followed by Ctrl+A	Select the entire ladder
Shift+Page Up	Selection Page-Up
Shift+Page Down	Selection Page-Down

5.4.3.1.5 Edit

Shortcut	Command
Ctrl+C	Copy Item
Ctrl+X	Cut Item
Ctrl+V	Paste Item
Return	Equivalent to double click
Space	Change contact or coil
Ctrl+Y	Redo
Ctrl+Z	Undo
Ctrl + mouse-wheel or + / – on the keypad	Zoom in / out
Ctrl+S	Save
Esc or Shift-ESC	Close the rename widget. Exit Dialog

5.4.3.1.6 Find

Shortcut	Command
Ctrl+F	Find
Ctrl + Shift + F	Find All
F3	Find Next

5.4.3.1.7 Delete

Shortcut	Command
Delete Key	Delete cell, selection, or row
Shift+Delete	Delete Network

5.4.3.1.8 Bookmark

Shortcut	Command
Ctrl+F2	Toggle Bookmark (you must first select the Network header)
Shift+F2	Go to Next Bookmark
Ctrl+Shift+F2	Go to Previous Bookmark

5.4.3.2 FFLD Editor (during debug)

Shortcut	Command
Spacebar	Swap TRUE/FALSE Boolean value
*	Lock var
/	Unlock var

5.4.4 Graphic Editor Keyboard Shortcuts

List of Graphics Editor Shortcuts

Shortcut	Command
Ctrl + mouse-wheel down or Shift+MINUS Sign (-) on the numerical keypad	Zoom out
Ctrl + mouse-wheel up or Shift+PLUS Sign (+) on the numerical keypad	Zoom in
Arrow	Scroll
Ctrl + F2	Toggle bookmark
Ctrl + arrow	Align on main selected item
Del	Delete selection
Escape	Cancel resizing/dragging If selection: Unselect If no selection: Select mode active
Ctrl + Shift + End	Select all items from the cursor position to the end of the document
Ctrl + Shift + Home	Select all items from the begin to the cursor position
Shift + F2	Go to next bookmark
Shift + Page UP/DOWN	Offset selection
Shift + Arrow	Move selection
Tab	Select next position item
Tab + shift	Select previous position item

5.4.5 SFC Editor Keyboard Shortcuts*List of SFC Shortcuts*

Shortcut	Command
?	Show/Hide notes
arrows	Move caret
Page UP/DOWN	Scroll page up/down
Return	Equivalent to double-click
Shift + arrows	Select multiple cells
Shift + Home	Select from left to caret
Shift + Page Up/Down	Selection Page Up/down
b or B	Insert macro body
c or C	Insert convergence
Ctrl + return	Edit reference
d or D	Insert divergence
Del	Delete selection
i or I	Insert step initial
j or J	Insert jump

Shortcut	Command
m or M	Insert macro
s or S	Insert step
Spacebar	Swap item style
t or T	Insert transition
x or X	Insert the left side corner of a divergence/convergence
Ctrl + mouse-wheel or + / – on the keypad	Zoom in / out

5.4.6 ST Editor Keyboard Shortcuts

- "ST Editor (common)" (→ p. 268)
- "ST Editor (when editing)" (→ p. 268)
- "ST Editor (during debug)" (→ p. 268)

5.4.6.1 ST Editor (common)

Shortcut	Command
Arrows	Move caret
Shift+arrows	Selection
Ctrl+left/right arrow	Go to previous/next word
Shift+Ctrl+left/right arrow	Select previous/next word
Ctrl+F2	Toggle Bookmark First, select the Network header)
Shift+F2	Go to Next Bookmark
Ctrl+Shift+F2	Go to Previous Bookmark
Ctrl+mouse-wheel or + / – on the keypad	Zoom in / out

5.4.6.2 ST Editor (when editing)

Shortcut	Command
.	Select member of a structure or instance.
Ctrl + Spacebar	Auto completion or Open the variable selector dialog.
Ctrl+Shift+Spacebar	Opens a list of all the standard functions.
Ctrl + J	Auto completion or Open the variable selector dialog (an alternative method).

5.4.6.3 ST Editor (during debug)

Shortcut	Command
*	Lock variable
/	Unlock variable
Shift+double-click	Force a variable
Spacebar	Toggle the Boolean value or activate the dialog, lock, unlock the variable. Equivalent of Shift + double click.

5.4.7 Table Keyboard Shortcuts

List of Table Shortcuts

Shortcut	Command
Arrows	Move selection
Shift + Tab	Move selection to the left
Spacebar	Line selection/cell selection
Tab	Move selection to the right

5.5 Bookmarks

Bookmarks are used for navigating in a document.

- Insert bookmarks anywhere in a document.
 - Use them to jump from one bookmark to another with a single command for browsing the document.
- Bookmarks are supported in all program editors plus the Variable editor.

These are the available commands for using bookmarks:

Command	Description
Ctrl + F2	Toggle the bookmark at the current position.
Shift + F2	Go to the next bookmark.

According to the type of document, the possible locations for a bookmark are:

- In the FBD editor, a bookmark is placed on any FBD object (not on a line).
- In the FFLD editor, a bookmark is placed on a rung header.
- In the SFC editor, a bookmark is placed on an SFC symbol (step, transition, jump...).
- In the text editor, a bookmark is placed on a line of text.
- In the Variable editor, a bookmark is placed on any line of the grid (variable or group).

NOTE

Bookmarks are valid only while the editing window is open.
They are not stored in the document when the window is closed.

5.6 Programs: Structure and Syntax

This section provides details on the syntax, structure, and use of the declarations and statements supported by the KAS-IDE application language.

5.6.1 Project Structure

Structuring the application with care is important in creating your project.

See "Project Structure Guidelines" (→ p. 623) in the "Advanced Topics" (→ p. 514).

5.6.2 IEC 61131-3 Editors

The KAS-IDE programming environment provides language dedicated editors for:

- "Function Block Diagram (FBD) Editor" (→ p. 274)
- "Free Form Ladder Diagram (FFLD) Editor" (→ p. 284)
- "Sequential Function Chart (SFC) Editor" (→ p. 293)
- "Structured Text (ST) / Instruction List (IL) Editor" (→ p. 299)

[When must SFC be used?](#)

- SFC must be used when you need to manage sequences of stable process states.
- Using SFC avoids complex switches and the declaration of multiple flags in programs.

When must SFC not be used?

- SFC must never be used as a decision diagram or flow chart for describing an algorithm (e.g., think If / Then / Else...).
- This leads to complex SFC charts and bad performances at run-time.
- Never use a step to represent an intermediate point within a calculation.
- Use ST in this case.

See "Program Limitations" (→ p. 717) and the "PLC Online Change" (→ p. 555) feature.

5.6.3 Tips

5.6.3.1 Drag-and-Drop

The editor provides a programming environment, including drag-and-drop features:

- Drag a variable from Dictionary and drop it into the program to insert it.
 - See "Variables tab" (→ p. 86).
- Drag a definition from the "Libraries" (→ p. 85) and drop it into the program to insert its name
- Drag a block and drop it into the program to insert it (you can even select the block from an external text file).
- Drag a function block to the variable list to declare an instance

5.6.3.2 Auto-completion

When you type the name of a function block instance (e.g., use either as an instance or a data structure), press the point (.) after the name of the instance opens a pop-up list with the names of possible elements.

Click the relevant element and validate it with the check mark.

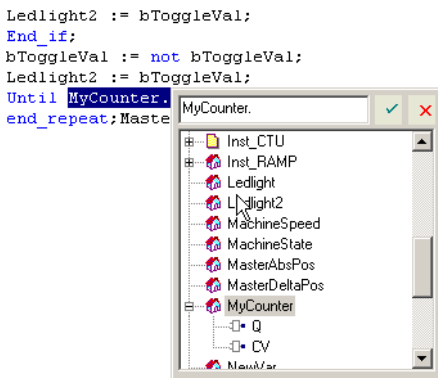
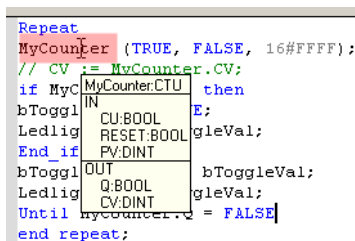

Figure 5-5: Autocompletion

5.6.3.3 Tooltip on Variable

When you leave the mouse cursor on a variable in Editors, a tooltip is shown to give you more details on the item.



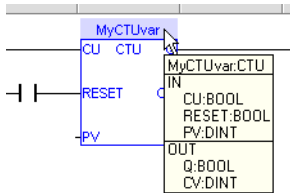

Figure 5-6: Tooltip on Variable

The header of the tooltip shows the name of the variable and its "Data Types" (→ p. 702).

5.6.3.4 Bookmarks

See "Bookmarks" (→ p. 269).

5.6.4 Select Function Blocks

All available Operators, functions and function blocks are listed in the "Libraries" (→ p. 85) toolbox.

- The list of available blocks is sorted into categories.
- The **(All)** category is used to see the complete list of available blocks.

Insert a Block in a Program

Select a block and drag-and-drop it to its position in the Editor.

TIP

Drag a function block from the Libraries and drop it in the variable list (Dictionary) to declare a new instance. Then drag this instance from the Dictionary and drop it in the program.

5.6.5 Select Variables and Instances

Symbols of variables and instances are selected using the variable list in the Dictionary.

Selecting variables is available from all editors:

- In FBD diagrams, double-click on a variable box, an FB instance name, a contact or a coil to select the associated variable.
- In FFLD diagrams, double-click on a contact, a coil or a block input or output to select the variable. Double-click on the top of an FB rectangle to select an instance.

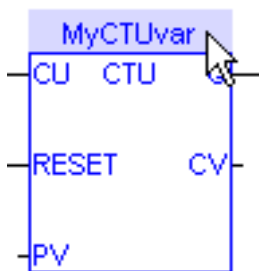

- When the variable editor is visible in the editor window, you can drag a variable from the list and drop it in the program to insert it.

Access a Single Bit of an Integer Variable

<variable>.<Bit number> (e.g., MachineState.7)

5.6.6 Drag and Drop Programming

The editor provides you with an ideal programming environment, including drag-and-drop features:

- Drag a variable from [Dictionary](#) and drop it into the program to insert it
- Drag a definition from [Libraries](#) and drop it into the program to insert its name
- Drag a block and drop it into the program to insert it (you can even select the block from an external text file).
- Drag a function block to the variable list to declare an instance

5.6.7 Autocompletion When Programming

When you type the name of a function block instance (use either as an instance or a data structure), pressing the point "." after the name of the instance opens a pop-up list with the names of possible elements. Click the relevant element and validate it with the check mark.

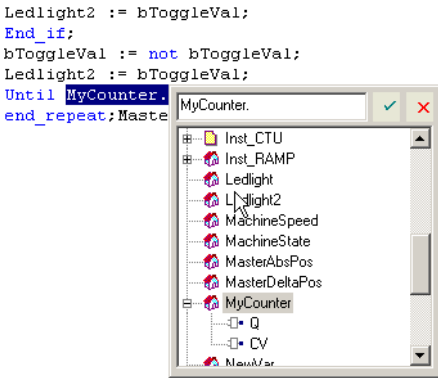

Figure 5-7: Autocompletion

also see "Auto-completion of Words" on page 301

5.6.8 Tooltips on Variables

When you leave the mouse cursor on a variable in Editors, a tooltip is displayed to give you more details on the item.

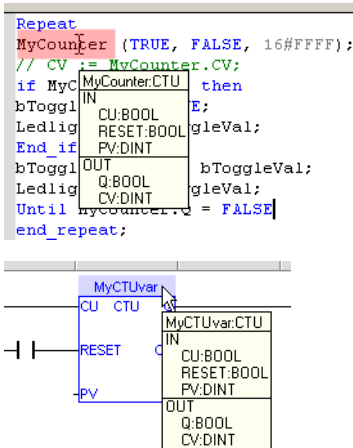

Figure 5-8: Tooltip on Variable

The header of the tooltip displays the name of the variable and its [type](#).

5.6.9 Selecting Function Blocks

All available Operators, functions and function blocks are listed in the [Libraries](#) toolbox. The list of available blocks is sorted into categories. The "(All)" category enables you to see the complete list of available blocks.

To insert a block in a program, select it and drag-and-drop it to the desired position in the Editor.

TIP

First drag a function block from the Libraries and drop it in the variable list (Dictionary) to declare a new instance. Then drag this instance from the Dictionary and drop it in the program.

5.6.10 Selecting Variables and Instances

Symbols of variables and instances are selected using the variable list in the [Dictionary](#). Selecting variables is available from all editors:

- In FBD diagrams, double-click on a variable box, an FB instance name, a contact or a coil to select the associated variable.
- In FFLD diagrams, double-click on a contact, a coil or a block input or output to select the variable. Double-click on the top of an FB rectangle to select an instance.

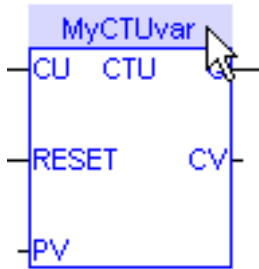

- When the variable editor is visible in the editor window, you can drag a variable from the list and drop it in the program to insert it.

How to access a single bit of an Integer variable?

<variable>.<Bit number> (e.g. MachineState.7)

5.6.11 Change Operators and Functions in FBD or FFLD Editors

Functions and operators can easily be edited and changed in the FBD or FFLD editors.

Double-clicking on a item in the editor opens a **Select** window which lets you change the entry to another function or operator, even of another type.

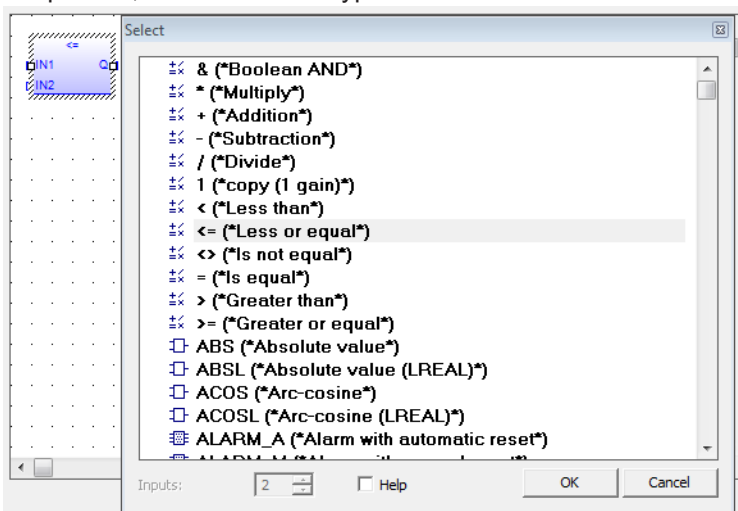

- When appropriate you can select the number of inputs.
 - This is most common for mathematical operations.
- Click the **Help** option opens the help topic for any selected operator, function, or function block.

TIP

This list is inclusive of function blocks.

A function or operator can be changed to a function block but variable assignment must be managed.

NOTE

This list includes numerous functions that are not valid for KAS. They are either not supported or have been deprecated.

See also "Change Function Blocks in FBD or FFLD Editors" (→ p. 274).

5.6.12 Change Function Blocks in FBD or FFLD Editors

- Double-clicking on the name of a function block in the FBD or FFLD editors allows you to select a different function block from a list of other FB instances.

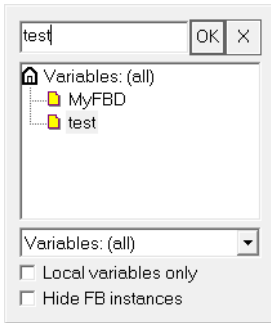

- Double-clicking on the main area of a function block in the FBD or FFLD editors allows you to change to a different operator, function, or function block. Be aware of any assigned variables likely to need modification.

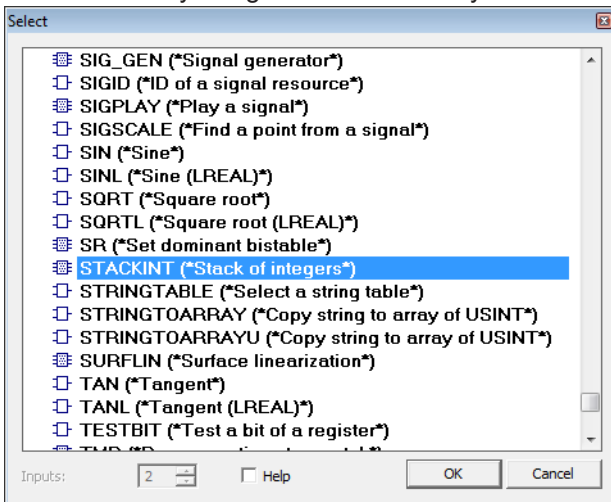

NOTE

This list includes numerous functions that are not valid for KAS. They are either not supported or have been deprecated.

See "Change Operators and Functions in FBD or FFLD Editors" (→ p. 273)

5.6.13 Function Block Diagram (FBD) Editor

The FBD Editor is a graphic tool used to enter and manage Function Block Diagrams according to the IEC 61131-3 standard.

- The editor supports advanced graphic features such as drag-and-drop, object resizing, and connection line routing features to rapidly and freely arrange the elements of a diagram.
- Insert in an FBD diagram graphic elements of the FFLD (Ladder Diagram) language (e.g., contacts and coils).

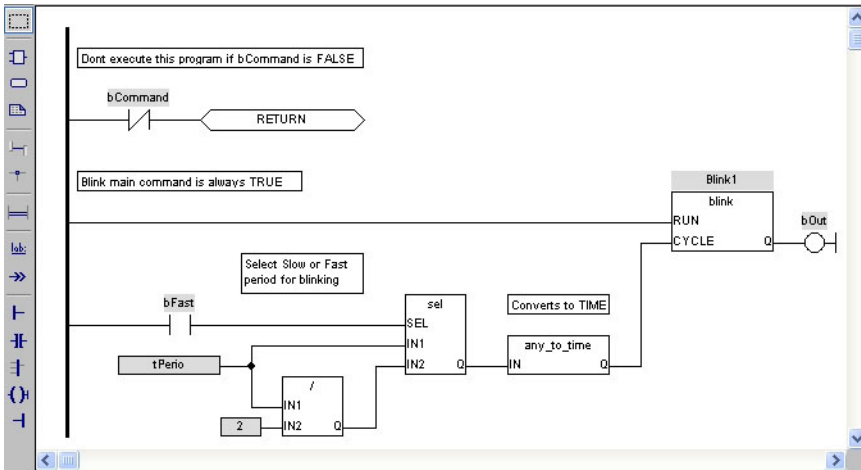

FBD Diagram Components	Related Sections
Function blocks	Using the FBD toolbar
Variable tags	Selecting Function Blocks
Comment texts	Drawing connection lines
Corners	Selecting and entering variables and FB instances
Network breaks	Viewing the diagram
Labels	Moving or copying parts of the diagram
Jumps	Inserting an object on a line
Use of ST instructions	Resizing objects
	Bookmarks
FFLD Components	
FFLD Contacts and Coils	
"OR" vertical rail	
Power rails	

NOTE
 When a contact or a coil is selected, press the **Spacebar** to change its type (e.g., normal, negated, pulse).

Boolean connections can be negative at the entry of a block.

[How to toggle the connection to make it negative?](#)

1. Select the Boolean connection

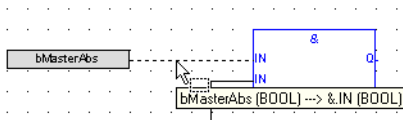

Connections in FBD Programs

2. Press the **Spacebar** (a small circle is displayed)

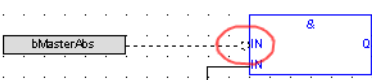

Toggle Connection in FBD Programs

Execution order can be displayed.

[How to display the execution order?](#)

Data flow is executed from top left to bottom right (**CTRL+d** shows the execution order).

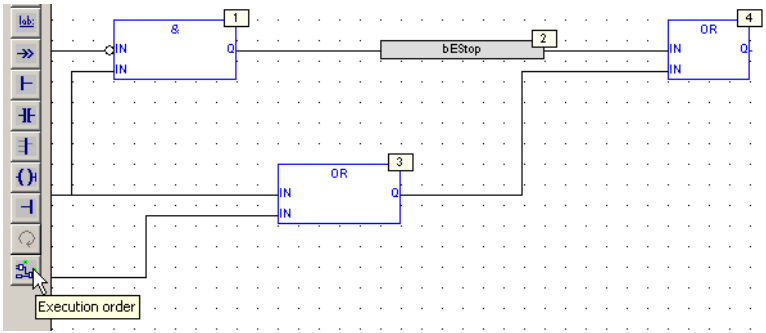







Figure 5-9: Execution Order on FBD







5.6.13.1 Using the FBD Toolbar

The vertical toolbar on the left side of the editor contains buttons for all available editing features.

Click the applicable button before using the mouse in the graphic area.

Tool	Button	Description
Execution Order		Show the execution order of the elements in the diagram.
Insert "OR" Rail		In this mode, the mouse is used to insert a rail that collects several Boolean data flows for an OR operation. This is used to insert parallel contacts, as in Ladder Diagrams.
Insert Block		In this mode, the mouse is used for inserting blocks in the diagram. <ul style="list-style-type: none"> Click in the diagram and drag the new block to the desired position. The type of block inserted is the one currently selected in the list on the main toolbar.
Insert Coil		In this mode, the mouse is used to insert a coil in the diagram (e.g., Ladder Diagrams). It is not required that a coil be connected on its right side.
Insert Comment Text		In this mode, the mouse is used for inserting comment text areas in the diagram. <ul style="list-style-type: none"> Comment texts can be entered anywhere. Click in the diagram and drag the text block to the desired position. The text area can be selected and resized.

Tool	Button	Description
Insert Connection Line		<p>In this mode, the mouse is used to wire the input and output pins of the diagram objects.</p> <ul style="list-style-type: none"> The line must always be drawn in the direction of the data flow: from an output pin to an input pin. The FBD editor automatically selects the best routing for the new line. <ul style="list-style-type: none"> You can change the default routing by inserting corners on lines. See "Insert Corner" (→ p. 277). You can drag a line from an output pin to an empty space. <ul style="list-style-type: none"> In this case, the editor automatically finishes the line with a user-defined corner. Continue drawing the connection to the designated pin and force the routing while drawing the line.
Insert Contact		<p>In this mode, the mouse is used to insert a contact in the diagram (e.g., Ladder Diagrams).</p>
Insert Corner		<p>In this mode, the mouse is used for inserting a user-defined corner on a line.</p> <ul style="list-style-type: none"> Corners are used to force the routing of connection lines. <ul style="list-style-type: none"> The FBD editor imposes a default routing only between two pins or user-defined corners. Corners can be selected and moved to change the routing of existing lines.
Insert Jump		<p>In this mode, the mouse is used to insert jump symbols in the diagram.</p> <ul style="list-style-type: none"> A jump indicates the execution must be directed to the corresponding label (having the same name as the jump symbol). Jumps are conditional instructions. Jumps must be linked on their left side to a Boolean data flow.
Insert Label		<p>In this mode, the mouse is used for inserting a label in the diagram.</p> <ul style="list-style-type: none"> A label is used as a destination for jump symbols. See "Insert Jump" (→ p. 277).

Tool	Button	Description
Insert Left Power Rail		<p>In this mode, the mouse is used to insert a left power rail in the diagram.</p> <ul style="list-style-type: none"> • A left power rail is an element of the FFLD language. • It represents a TRUE state that used to initiate a data flow. • Power rails can be selected and resized vertically according to the desired network height.
Insert Network Break		<p>In this mode, the mouse is used for inserting a horizontal line that acts as a break in the diagram.</p> <ul style="list-style-type: none"> • Breaks have no meaning for the execution of the program. • Breaks aid in the understanding of big diagrams by splitting them into a list of networks.
Insert Right Power Rail		<p>In this mode, the mouse is used to insert a right power rail in the diagram.</p> <ul style="list-style-type: none"> • A right power rail is an element of the FFLD language. • It is used for terminating Boolean data flows. • It is not required to connect coils to power rails. • Right power rails have no meaning for the execution of the diagram.
Insert Variable		<p>In this mode, the mouse is used for inserting variable tags.</p> <ul style="list-style-type: none"> • Variable tags can be wired to the input and output pins of the blocks. • Click in the diagram and drag the new variable to the its position.
Selection		<p>In this mode, you cannot insert any elements into the diagram.</p> <ul style="list-style-type: none"> • The mouse is used to select object and lines, select tag name areas, or move or copy objects in the diagram. • Press the ESCAPE key to return to the Selection mode.
Swap Item Style		Change the text justification.

5.6.13.1.1 FBD Variables

All variable symbols and constant expressions are entered in FBD diagrams using small boxes.

1. Click this button in the FBD toolbar to insert a variable tag:
 **Insert variable:** In this mode, the mouse is used for inserting variable tags.
Click in the diagram and drag the new variable to the desired position.
2. Double-click a variable tag to open the variable selection box.
See "Select FBD Variables and Instances" (→ p. 281) for more information.

3. Either select the symbol of a variable or enter a constant expression.
Variables tags must be linked to other objects (e.g., block inputs and outputs) using connection lines.
4. Resize a variable box vertically to display, together with the variable name, its tag (short comment text), and its description text.

The variable name always appears at the bottom of the rectangle:

Display Item	Example
Description	Sample Description
Tag	Sample Tag
Name	SomeVariable

See "Variables tab" (→ p. 86) for more information.

5.6.13.1.2 FBD Comments

Comment text area can be entered anywhere in an FBD diagram.

- Select the Insert Comment Text button  in the FBD toolbar to insert a new comment area.
- In this mode, the mouse is used to insert comment text areas anywhere in the diagram.
- Click in the diagram and drag the text block to the desired position.
- Double-click on the comments area to enter or change the attached text.
 - When selected, comment texts can be resized.
 - See "Resize FBD Objects" (→ p. 283).

NOTE

A hyperlink can be inserted in external files.
Only TXT and BMP extensions are allowed.
When the link is valid, the hyperlink is replaced with the file's content.

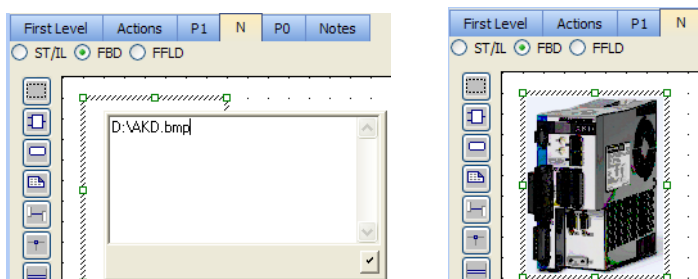

Figure 5-10: FBD Comments - Inserting Graphic

5.6.13.1.3 FBD Corners

Corners are used to force the routing of connection lines, as the FBD editor imposes a default routing only between two pins or user-defined corners.

All variable symbols and constant expressions are entered in FBD diagrams using small boxes.

Select the Insert Corner button in the FBD toolbar to insert a corner on a line:



Insert corner: In this mode, the mouse is used to insert a user-defined corner on a line.

- Drag a new line from an output pin to an empty space.
 - In this case, the editor automatically finishes the line with a user-defined corner.
 - Continue drawing the connection to the desired pin and force the routing while you are drawing the line.
- Corners can then be selected and moved to change the routing of existing lines.

5.6.13.1.4 FBD Network Breaks

Network breaks can be entered anywhere in an FBD diagram.

- Breaks have no meaning for the execution of the program; they just help in understanding big diagrams, by splitting them into a list of networks.
- Select the Insert Network Break button in the FBD toolbar to insert a new break:



Insert network break: In this mode, the mouse is used for inserting a horizontal line that acts as a break in the diagram.

- The break line is drawn on the whole diagram width.
 - No other object can overlap a network break.
 - Break lines can then be selected and moved vertically to another location.
- Network breaks can also be used to browse the diagram.
 - Press the **Ctrl+Page Up** or **Ctrl+Page Down** keys to move the selection to the next or previous network break.

5.6.13.1.5 FBD OR Vertical Rail

The FBD Editor enables the drawing of FFLD rungs.

- The OR rail can be inserted on a rung in order to connect parallel contacts together.
- In the FBD toolbar, click the **Insert OR Rail** button () to insert a new OR rail.
 - In this mode, the mouse is used to insert a rail that collects several Boolean data flows for an OR operation to insert parallel contacts (e.g., Ladder Diagrams).
- The OR rail has exactly the same meaning as an OR block regarding the execution of the diagram.

5.6.13.2 Draw FBD Connection Lines



Click this button before inserting a new line.

NOTE

The editor is used to terminate a connection line with a Boolean negation represented by a small circle: (* use of a negated link: Q is IN1 AND NOT IN2 *)





To set or remove the Boolean negation, select the line and press the <Spacebar>.

- Connection lines must always be drawn in the direction of the data flow: from an output pin to an input pin.
- The FBD editor automatically selects the best routing for the new line.
- Connection lines indicate a data flow between these possible objects:

NOTE

Line is colored in red when the two linked items are not the same type.

Tool	Button	Description
Block		See the help for the block for the description of its input and output pins, and the expected data types for the coherence of the diagram.
Coil		A coil must be connected to a Boolean data flow from its left-hand side. It is not mandatory that a coil be connected on its right-hand side.
Contact		A contact must be connected to a Boolean data flow on both its left- and right-hand side.

Tool	Button	Description
Jump		A jump must be connected to a Boolean data flow from its left-hand side.
Left power rail		Left power rails represent a TRUE state. It can be connected to an unlimited number of objects on their right-hand side.
OR rail		This type of rail collects several Boolean data flows for an "OR" operation, in order to insert parallel contacts (e.g., Ladder Diagrams). <ul style="list-style-type: none"> An OR may have several connections on both its left- and right-hand side. All connected data flows must be Boolean.
Right power rail		A right power rail is an element of the FFLD language, and is commonly used for terminating Boolean data flows. <ul style="list-style-type: none"> It has an unlimited number of connections on its left-hand side. It is not mandatory to connect coils to power rails.
Variable		A variable can be connected on its right-hand side (to initiate a flow) or on their left-hand side to force the variable, if it is not read-only. The flow must fit the data type of the variable.

TIP

Connection lines automatically move and follow FBD elements (1) and you can also manually specify the corners.

Double-click on the line to show a handle (2) which can be repositioned (3).

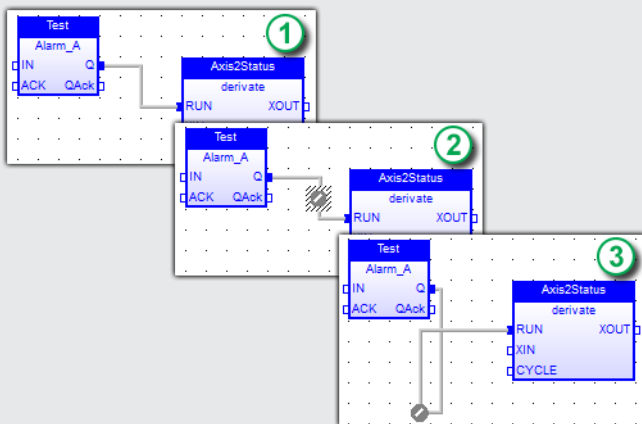

5.6.13.3 Select FBD Variables and Instances





Click this button or press <Esc> before any selection.

To select the name of the declared variable to attach to a graphic symbol, you must be in Selection mode.

Double-click on the tag-name gray area.

These types of object must be linked to valid symbols:

Tool	Button	Description
Block		For a function block, you must specify the name of a valid declared instance of the corresponding type.

Tool	Button	Description
Coil		Must be attached to a declared Boolean variable.
Contact		Must be attached to a declared Boolean variable.
Jump		Must have the same name as its destination label.
Label		Must have a name. The name must be unique within the diagram.
Variable		Must be attached to a declared variable. Alternatively, a variable box may contain the text of a valid constant expression.

Symbols of variables and instances are selected using a variable list, that can be used as the variable editor.

1. Enter a symbol or constant expression in the **Edit** box and click **OK**.
2. Select a name in the list of declared objects or click the **Create** button to declare a new variable.

See Select Variables and Instances.

5.6.13.4 View FBD Diagrams

The diagram is entered in a logical grid.

- All objects are snapped to the grid.
- The (x,y) coordinates of the mouse cursor appear in the status bar.
 - This helps locate errors detected by the compiler or to align objects in the diagram.
- Press <CTRL+ scrolling mouse wheel> to zoom in or out of the edited diagram or press the <+> and <-> keys of the numeric keypad.

5.6.13.5 Move or Copy FBD Objects



Click the Selection Mode button or press <Esc> before selecting objects.

The FBD editor supports drag-and-drop for moving or copying objects.

- To move objects, select and drag them to the desired position.
- To copy objects, press <Ctrl> while dragging.
 - It is also possible to drag pieces of diagrams from one program to another if both are open and visible on the screen.
- At any time while dragging objects, press <Esc> to cancel the operation.
- Use the Copy / Cut / Paste commands from the Edit menu.
 - When you run the Paste command, the editor changes into Paste mode, with a special mouse cursor.
 - Click in the diagram and move the mouse cursor to the desired position for inserting pasted objects.

5.6.13.5.1 Use the Keyboard

5.6.13.5.2.1 Move Objects

When graphic objects are selected, press these keys to move them in the diagram:

Keys	Description
<Shift + Up>	Move to the top.
<Shift + Down>	Move to the bottom.
<Shift + Left>	Move to left.
<Shift + Right>	Move to right.

5.6.13.5.3.2 Extend Object Selection

When an object is selected, press these keys to extend the selection:

Keys	Description
<Shift + Control + Home>	Extend to the top: select all objects before the selected object.
<Shift + Control + End>	Extend to the bottom: select all objects after the selected object.

5.6.13.5.4.3 Insert or Delete Space

To insert or delete space in the diagram:

1. Select an object.
2. Press <Shift+Ctrl+End> to extend the selection.
3. Move selected objects up or down.

5.6.13.5.5.4 Auto-alignment

When objects are selected, press these keys to automatically align them:

Keys	Description
<Control + Up>	To the top.
<Control + Down>	To the bottom.
<Control + Left>	To left.
<Control + Right>	To right.

5.6.13.6 Insert FBD Objects on a Line

The FBD editor is used to insert an object on an existing line and automatically connect it to the line.

- This feature is available for all objects having one input pin and one output pin (e.g., variable boxes, contacts, coils).
- This feature is mainly useful when entering elements of Ladder Diagrams.
 - Draw a horizontal line between left and right power rails: it is the rung.
 - Then insert contacts and coils on the line to build the FFLD rung.

5.6.13.7 Resize FBD Objects

When an object is selected, small square boxes indicate how to resize it with the mouse.



Click this button or press <Esc> before selecting objects.

Click the small square boxes to resize the object in the desired direction.

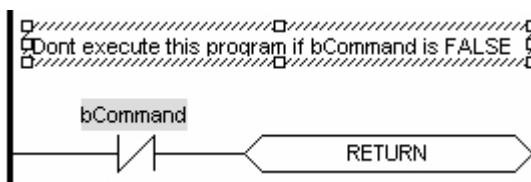

Not all objects can be resized.

This table indicates possible operations:

Operation	Description
Block	Horizontally

Operation	Description
Comment area	In all directions.
Labels and jumps	Horizontally
OR rail	Vertically
Power rails	Vertically
Variable	Horizontally and vertically (*)

(*) Resizing a variable box vertically enables you to display together with the variable name its tag (short comment text) and its description text.

The variable name is always shown at the bottom of the rectangle:

```

description
  tag
  name
    
```

5.6.14 Free Form Ladder Diagram (FFLD) Editor

The FFLD Editor is a graphic tool used to enter and manage ladder diagrams according to the IEC 61131-3 standard.

This editor enables:

- Free drawing and arrangement of FFLD items.
- Supports these advanced graphic features:
 - "Change Ladder Diagram Size" (→ p. 284)
 - "Color-coded Functions" (→ p. 284)
 - "Coordinate-based Positions" (→ p. 285)
 - "FFLD Move and Copy Items" (→ p. 292)
 - "Select the Entire Ladder Diagram" (→ p. 285)
 - "Split Window Capability" (→ p. 286)

See Also

- "FFLD Networks" (→ p. 288)
- "FFLD Runtime" (→ p. 289)

5.6.14.1 Advanced Graphic Features

5.6.14.1.1 Change Ladder Diagram Size

Diagram Size

Drag the column separator to increase or decrease the size of the columns.

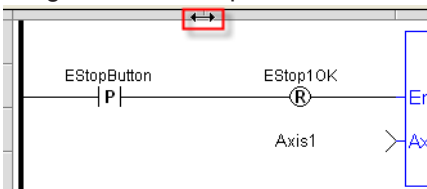

Drag the row separator to increase or decrease the size of the rows as well as the texts.

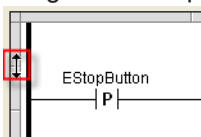

5.6.14.1.2 Color-coded Functions

Color Coded Function

- Functions and Function Blocks are color-coded as blue.
- Sub-programs and Kollmorgen UDFBs are black.

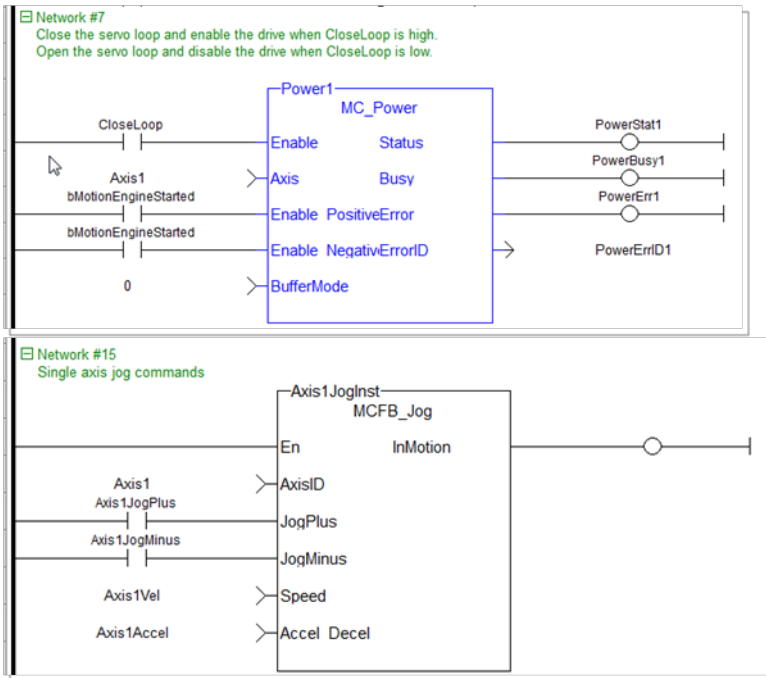

5.6.14.1.3 Coordinate-based Positions

Coordinate-based Position

The coordinates for a selected function are displayed at the bottom-left corner of the editor.
The coordinates are shown in this format:

(absolute coordinates)-(network number).(relative coordinates) in (column, row)

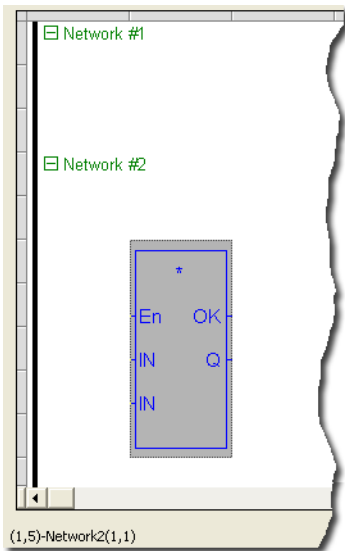

NOTE

Relative coordinates are measured from below the Network label.

5.6.14.1.4 Select the Entire Ladder Diagram

Select All

Click the border in the upper left corner to select the entire ladder.

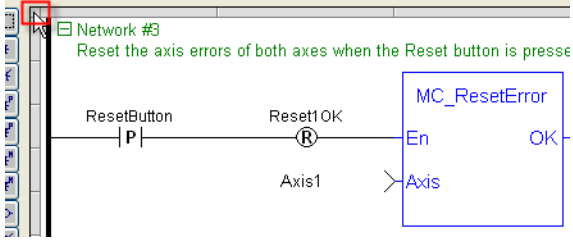

5.6.14.1.5 Split Window Capability

Split Window

Allows multiple views of the same ladder program to be displayed simultaneously.

Drag the two splitters located in the vertical and horizontal scroll bars to organize the windows.

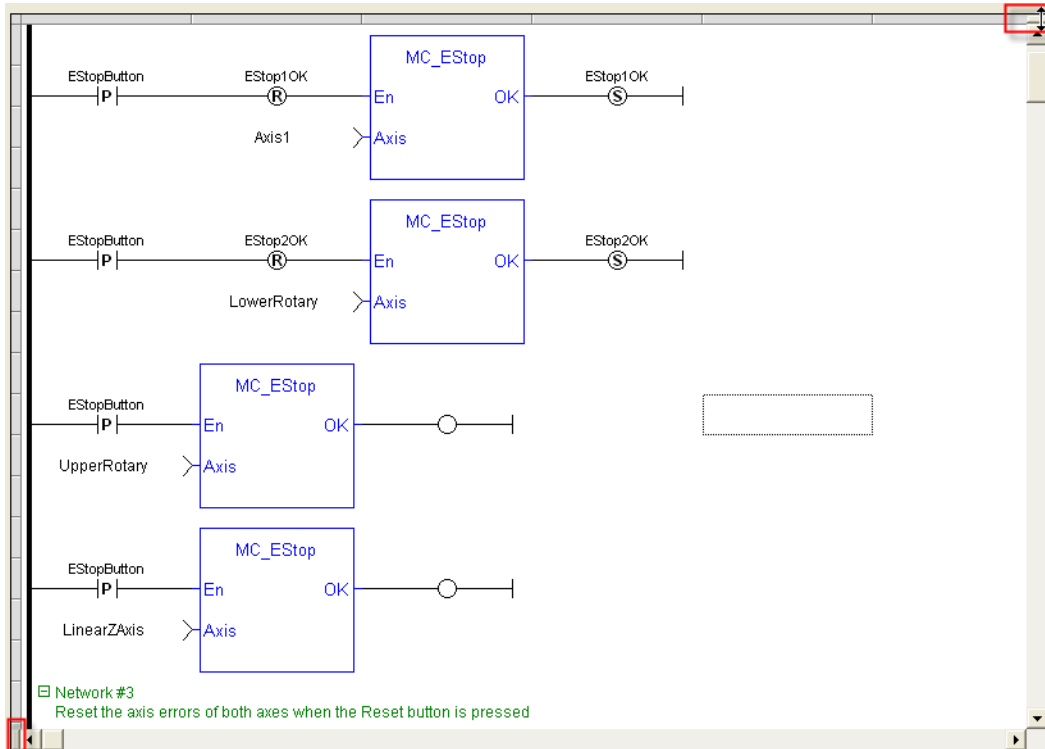

FFLD Diagram Components	Related Sections
<ul style="list-style-type: none"> • "FFLD Power Rail and Lines" (→ p. 289) • "FFLD Contacts and Coils" (→ p. 290) • "FFLD Function Blocks" (→ p. 290) • "FFLD Data In / Data Out" (→ p. 290) • "FFLD Jumps and RETURN" (→ p. 291) • "FFLD Networks" (→ p. 288) 	<ul style="list-style-type: none"> • "FFLD Toolbar and Right-click Menu" (→ p. 286) • "FFLD Selection Grid" (→ p. 291) • "FFLD Move and Copy Items" (→ p. 292) • "FFLD Runtime" (→ p. 289)

TIP

When a contact or a coil is selected, you can press the **Spacebar** to change its type (normal, negated, pulse)

5.6.14.2 FFLD Toolbar and Right-click Menu

























This section describes the "Toolbar" (→ p. 286) buttons and "Right-click Menu" (→ p. 288) of the FFLD Editor.



See (→ # 263, FFLD Editor Keyboard Shortcuts) for more information about the FFLD accelerator keys.

5.6.14.2.1 Toolbar

The vertical toolbar on the left side of the FFLD Editor uses buttons to insert items in the diagrams.

Items are inserted at the current position in the diagram.

Button	Shortcut	Description
		Mode selection
	Ctrl+Shift+O	Insert a contact to the destination cell.
	Ctrl+Shift+C	Insert an inverted contact to the destination cell.
	Ctrl+Shift+P	Insert a Pulse contact to the destination cell.
	Ctrl+Shift+I	Insert an inverted Pulse contact to the destination cell.
	Ctrl+Shift+N	Insert a N contact to the destination cell.
	Ctrl+Shift+A	Insert an inverted N contact to the destination cell.
	Ctrl+Shift+E	Insert a coil to the destination cell.
	Ctrl+Shift+D	Insert an inverted coil to the destination cell.
	Ctrl+Shift+S	Insert a set coil to the destination cell.
	Ctrl+Shift+R	Insert a reset coil to the destination cell.
	Ctrl+Shift+K	Insert a positive coil to the destination cell.
	Ctrl+Shift+L	Insert a negative coil to the destination cell.
	Ctrl+Shift+H	Trace a horizontal line to the destination cell.
	Ctrl+Shift+V	Trace a vertical line to the destination cell.
	Ctrl+Shift+B	Trace a vertical and horizontal line to the destination cell.
		Toggle trace mode. Click and move the mouse to draw a line spanning on several adjacent cells.
	Shift+Insert	Insert a network.
	Ctrl+Shift+J	Insert a jump.
	Ctrl+Shift+T	Insert a return.
	Ctrl+Shift+F	Insert a data in.
	F8	Insert a function block.
	Ctrl+Shift+Q	Insert a data out.
	Spacebar	Swap item style of the current cell for a contact or coil.

Button	Shortcut	Description
		Define a network label, pragma, and/or comment.
	Shift+C	Define a comment in a cell. Click the button, then select the cell to add a comment to. See "Right-click Menu" (→ p. 288) for more information about cell comments.

5.6.14.2.2 Right-click Menu

Right-click in the FFLD workspace to use these commands:

- Insert Comment
 - Comments may be added to cells.
 - If the text is long, it is shown beyond the bounds of the cell (to the right, and below) until another item is found.

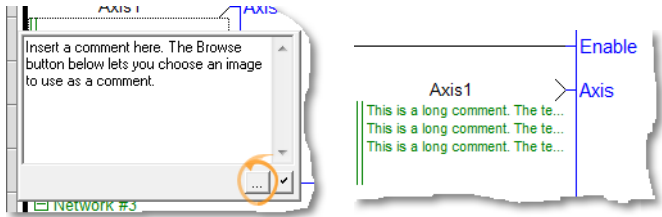

- Insert Network
- Insert Row
- Delete Cell
- Delete Network
- Delete Row

5.6.14.3 FFLD Networks

A program is entered as a list of independent networks.

- Networks are executed sequentially from the top to the bottom.
- The head of a network is drawn on a full row in the editor, grouping this information:
 - The number of the network (from 1 to N)
 - (Optional) A label name used as a target for jump operations.
 - See "FFLD Jumps and RETURN" (→ p. 291).
 - (Optional) A directive for "Conditional Compiling" (→ p. 223).
 - (Optional) A multiple line description (comment).

5.6.14.3.1 Header Row

No item can be put on a network header row.

- No line can go through it.
- The end of a program is marked with a special "End of module" row.
- Nothing can be inserted after this row.

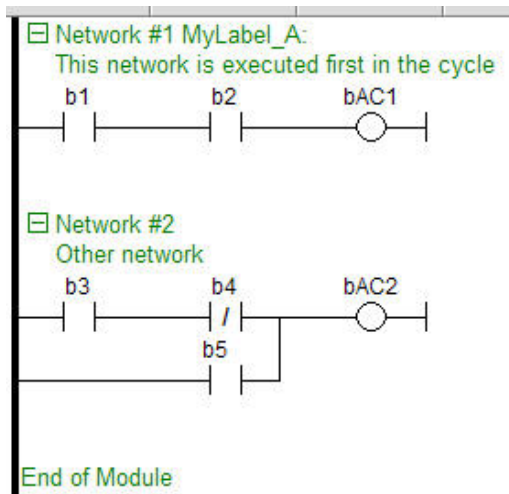

- Double-click the header of a network to enter its label, directive (sometimes called pragma) and description.
- Network headers are green.
 - They became blue when a directive is defined.
 - See (→ # 223, Conditional Compiling).

5.6.14.3.2 New Networks

New networks can be inserted on empty rows.

- When a network is selected, pressing merges its content with the previous network.
 - When the first network is selected, pressing removes the network and all its contents.
- There cannot be two networks having the same label in a program.
 - If this situation occurs in the case of a copy operation, you are prompted to either:
 - Specify another label name for the new network.
 - Remove the label on the new network.

Collapse/expand a network with the minus/plus sign located next to the Network number in the header.

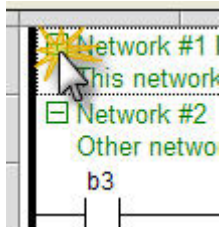

5.6.14.4 FFLD Runtime

When your application is running, you can force and lock a variable or a contact directly in the editor with a double-click operation.

See "Forcing a Variable" (→ p. 242) for more information.

NOTE

In FFLD, when a function, function block or UDFB is not connected on the left, removed at compiling time.

5.6.14.5 FFLD Power Rail and Lines

Vertical power rails are used in the FFLD Language to represent the limits of a rung.

- The power rail on the left represents the TRUE value and initiates the rung state.
 - Any object connected to this rail is always powered.
- Horizontal lines always represent a data flow from the left to the right.

- If a vertical line has several items connected on the left, then it represents an OR / ORN operation.
- You can insert a segment of horizontal line at any location to freely draw flow lines.
 - The vertical line button is used to set or remove (toggle) a segment of vertical line on the right of the selected cell.

5.6.14.6 FFLD Contacts and Coils

This is a list of the FFLD contact and coil types:

Contacts	Coils
Negative Transition - N -	Reset (Unlatch) -(R)-
Normally Closed - /-	De-energize -(I)-
Normally closed negative transition - /N -	Negative transition sensing coil -(N)-
Normally closed positive transition - /P -	Positive transition sensing coil -(P)-
Normally Open - -	Energize -()-
Positive Transition - P -	Set (Latch) -(S)-

See Also

- FFLD Coils
- FFLD Contacts

5.6.14.7 FFLD Function Blocks

Functions and function blocks can be used in FFLD diagrams.

- Blocks are always connected to the flow line (powered) by their first input and first output.
 - If the first input of a block is not Boolean, a special input called EN is added.
 - This means the block is not executed if the input flow is FALSE.
 - If the first output is not Boolean, a special output called OK is added.
 - The special OK output always has the same state as the first input (the flow).
- In a function block, the instance of the block must be specified and is shown on the top of the block.
 - Double-click the top of the block to select the instance.
 - Double-click elsewhere in the block to change its type.
- Boolean inputs and outputs of blocks can be directly linked to contacts and coils.
 - Block inputs and outputs can be specified using specific "FFLD Data In / Data Out" (→ p. 290) items.

NOTE

Function and function blocks cannot be put in column 1 of the grid. This would not make sense because data inputs require a column.

- You cannot change a function block after it has been inserted.
- When a function is not connected on the right, it is ignored (removed at compiling time).
 - It is a case for functions only - **not** for function blocks.
 - A function is just part of an expression (same as a contact) and is intended to provide a result.
 - With FFLD, KAS accepts that the output is not connected because it accepts pending dead expressions to be removed at compiling time (same as contacts with no coil or FBs after).

TIP

If you want another function block, you first have to select it in the Libraries toolbox before inserting it.

5.6.14.8 FFLD Data In / Data Out

The data in and data out items are used to either:

- Initiate a flow (line) with the value of a variable.
- Force a variable on output with the value of a flow:

```
VarIn>- ..... ->VarOut
```

When used with a block, the data in and data out items can be put close to the block, without any line in-between to connect a variable to an input or output of the block.

Example

The @ symbol in front of the V variable indicates it is used for input and output.

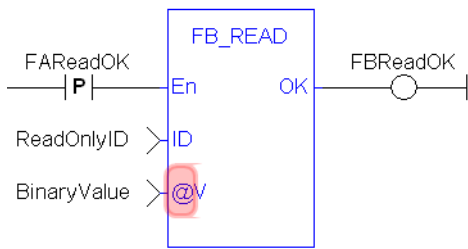

5.6.14.9 FFLD Jumps and RETURN

A jump to a label branches the execution of the program after the specified label.

- In the FFLD Language, the >> symbol (followed by the target label name) is used as a coil at the end of a rung.

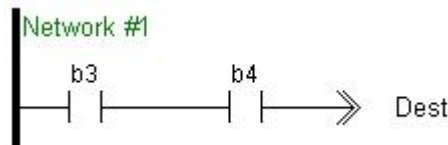

- The jump is performed only if the rung state on input is TRUE.
 - The destination label must be specified on a network of the same program.
 - To specify the destination, double-click the cell to display a drop-down menu that lists all the available labels.

NOTE
The special <RETURN> destination specifies a jump to the end of the program.

5.6.14.10 FFLD Selection Grid

The diagram is entered in a logical grid, and all objects are snapped to the grid.

- Use the **View** menu commands to see hiding grid points.
 - This helps locate errors detected by the compiler or aligning objects in the diagram.
- Zoom in or out of the edited diagram.
 - See "FFLD Toolbar and Right-click Menu" (→ p. 286).
- Drag the separation lines in vertical and horizontal rulers to freely resize the cells of the grid:

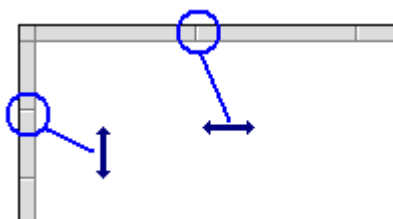

NOTE

If a split window is in use, the zoom applies only to the currently selected split window (each split window can be zoomed to different levels).

- The current position in the grid is always highlighted by a dotted cell.
 - Its coordinates (row, column) are displayed at the bottom left-hand corner of the editor.
- Click the current position, the cell is drawn as gray, meaning that it can be dragged somewhere else in the diagram.
 - Select multiple cells with the mouse, or use the arrows of the keyboard with the <SHIFT> key pressed.
- Click the power rail (gray ruler at the left border) to select a full row.

These commands are available from the keyboard:

Keys	Description
Arrows	Move focus cell or scroll through ladder.
Ctrl-Shift-F2	Go to previous bookmark.
Ctrl + A	Selects the whole network. If pressed again, selects the whole program.
Ctrl + F	Performs a Search and Replace (+ add hyperlink on the topic) within the whole program.
Ctrl + Home/End twice	Moves the cursor to the beginning or the end of the program.
Ctrl + Page Up Down	Moves the cursor to previous or next network header.
End	Moves the cursor to the end of the line. If pressed again, moves the cursor to the end of the network.
Esc / Shift-Esc	Close the rename widget.
Home	Moves the cursor to the left of the line. If pressed again, moves the cursor to the head of the network.
Page Up / Down	Scroll 1 page.
Return	Equivalent to a double-click.
Shift-Arrow	Multi-select cells.
Shift-Page Up / Down	Selection page up or down.
Shift-Tab	Move focus cell left.
Space	Change contact or coil.
Tab	Move focus cell right.

5.6.14.11 FFLD Move and Copy Items

When you click on the current position, the cell is drawn as gray, meaning that it can be copied or moved.

Click the selection again to drag it with the mouse.



- Dragging the selected items moves them to the specified location.
 - If you press the <Ctrl> key while dragging, then items are copied.
 - For shortcuts, see "FFLD Toolbar and Right-click Menu" (→ p. 286).
- To move a function block, you must select it entirely.
- If you move or copy items on a non-empty area, you are prompted to confirm the overwriting of items in the area.
- When you move or copy items only on a network header, the network is automatically moved to make the required extra space for moved items.
- The Copy / Cut / Paste commands can be used as an alternative to drag-and-drop.
- A rectangular selection within the diagram cannot cross a network header (i.e., all selected items must be within the same network).
 - To select a complete network or more, you must select complete rows.
 - To do this, move the caret to the left border or click on the left-hand side ruler (gray).

5.6.14.12 View FFLD Diagrams

The diagram is entered in a logical grid. All objects are snapped to the grid.

- The (x,y) coordinates of the mouse cursor are displayed in the status bar.
 - This helps to locate compiler detected errors or to align objects in the diagram.
- Zoom in or out of the edited diagram using either:
 - A <Ctrl + mouse-wheel> operation.
 - Press the <+> and <-> keys of the numerical keypad.
- Drag the separation lines in vertical and horizontal rulers to freely resize the cells of the grid:

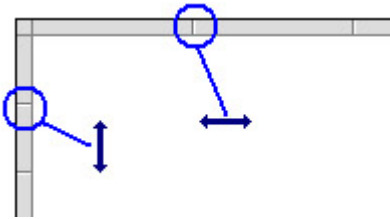

- The FFLD editor adjusts the size of the font according to the zoom ratio so that the name of variables associated with contacts and coils are always visible.
- If cells have sufficient height, variable names are completed with other these pieces of information about the variable:
 - Tag (short description).
 - Description text.
 - I/O name (%...) if the variable has a user-defined name.

5.6.15 Sequential Function Chart (SFC) Editor

The SFC Editor is a graphic tool used to enter and manage Sequential Function Chart according to the IEC 61131-3 standard.

The editor supports advanced graphic features such as drag-and-drop, so that you can freely and rapidly arrange the elements of your diagram. It also supports automatic chart formatting when inserting or deleting items, and thus enables quick input using the keyboard.

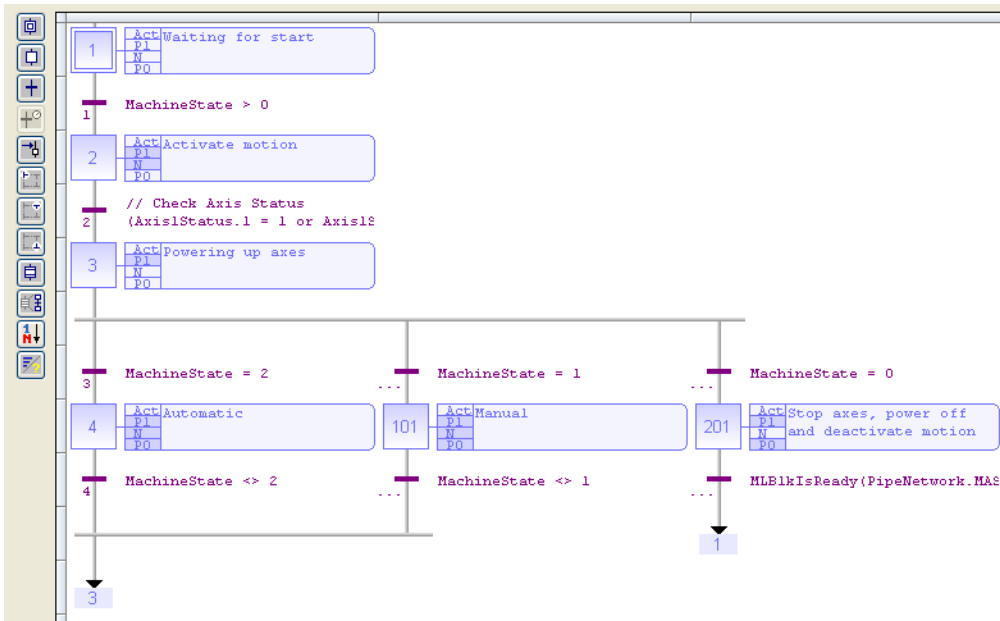

NOTE

For each step, the cells referring to P1, N, and PO actions are colored when they are defined.

TIP

- Select a step, transition, or jump and press **Ctrl+ENTER** to change its number.
- Press the **Spacebar** on the main corner (on the left) of a ulergence or convergence, to set either double or single horizontal line style.

5.6.15.1 Using the SFC Toolbar

The vertical toolbar on the left side of the editor contains buttons for inserting items in the chart.

- Items are always inserted before the selected item.
- The chart is automatically re-arranged when a new item is inserted.

Use these keyboard commands when an item is selected:

1. **ENTER**: Edit Level 2 of a step or transition.
 - **Ctrl+ENTER**: Change the number of a step, transition, or jump.

Toolbar Button	Description
Initial step (I)	Inserts an initial step.
Step (S)	Inserts a step.
Transition (T)	Inserts a transition.
Set Timer on Transition	Sets a timer on a transition. <ul style="list-style-type: none"> • Example: 5 on step number 4 leads to a transition with <code>GS4.T>T#5ms</code>. • Previously, the window showing the content of the transition must be closed.
Jump (J)	Inserts a jump to a step.
Divergence (X)	Inserts the main (left side) corner of a divergence or convergence.
Divergence (D)	Inserts a divergence corner.
Convergence (C)	Inserts a convergence corner.

Toolbar Button	Description
Insert Comment	Inserts a comment.
Change Display	Swaps between possible overviews of level 2 in the level 1 chart: <ul style="list-style-type: none"> • Show all. • Show the code of actions and conditions. • Show notes attached to steps and transitions.
Swap Item Style	Allows changes to the item style. Changes either: <ul style="list-style-type: none"> • A step to an initial step (and the reverse) . • An OR divergence / convergence to an AND divergence / convergence (and the reverse).
Renumber	Renumbers all steps and transitions. Previously, the window showing the content of a step or a transition must be closed.
Edit Reference	Edits the number of a step, transition or jump. Previously, the window showing the content of a step or a transition must be closed.
Show one qualifier in level 2	Shows one level of the edition in the level 2 of the SFC Editor. Example: Shows only the P1 of a step.
Show/Hide splitted window in level 2	Shows two levels of the edition in the level 2 of the SFC Editor. Example: Show P1 and Notes of a step.
Show all qualifiers in level 2	Shows every level of the level 2 on the SFC Editor.

5.6.15.1.1 Edition window

Open the Edition window using a click on ENTER, when an item is selected.

- The level 2 of a step or a transition can be edited in this window.
- The different levels of editions in the level 2 of the SFC Editor can be selected using the buttons at the top of the Edition window.

Toolbar Button	Description
Action	Shows/hides the action box in the SFC level 2.
P1	Shows/hides the P1 box in the SFC level 2.
N	Shows/hides the N box in the SFC level 2.
0	Shows/hides the P0 box in the SFC level 2.
Notes	Shows/hides the Notes box in the SFC level 2.
Close level 2	Closes the SFC level 2.

5.6.15.2 Draw SFC Divergences



When using the SFC editor, you need to place items in the grid.

The editor calculates and draws lines automatically to link the steps and transitions and jumps to your place in the chart.

The same method is used for drawing divergences:

- Place the corners that identify divergences, convergences, and branches.
- The editor takes care of drawing vertical and horizontal lines.

Use these buttons in the SFC toolbar:

Button	Description
	Insert the main (left side) corner of a divergence or convergence.
	Insert a divergence corner.
	Insert a convergence corner.

ⓘ IMPORTANT

Divergences are always drawn from left to right. The first branch, on the left, contains the corners that identify the divergence. It must be aligned with the preceding step or transition:

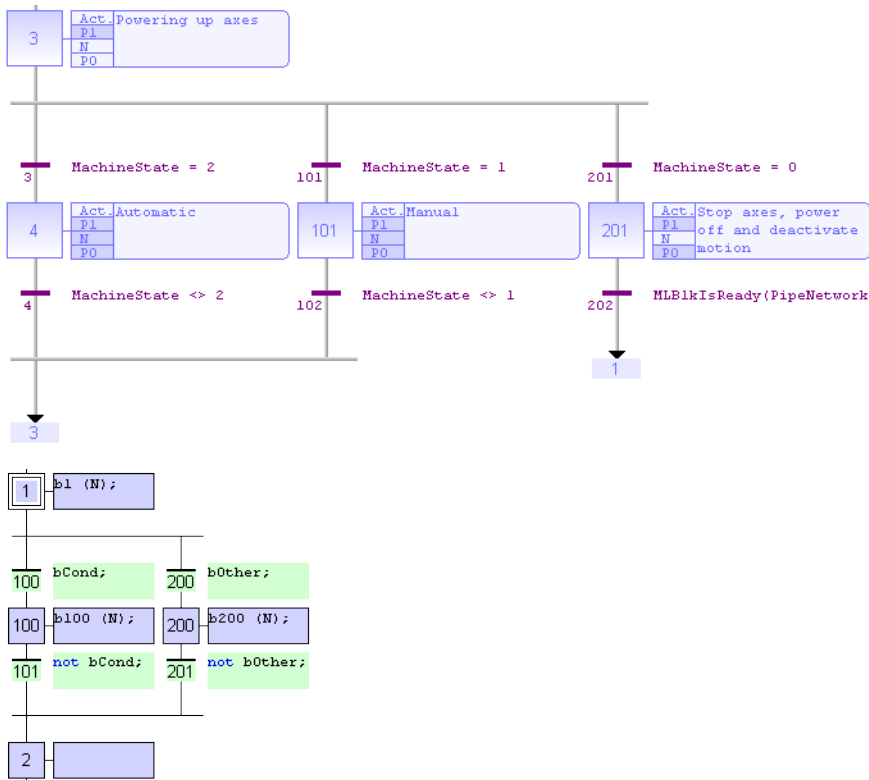

Procedure

1. Insert the main corner (on the left-hand side branch) of the divergence and the convergence.
2. Insert corners at the top of each branch (divergence).
3. Insert corners at the bottom of the branches where a divergence is required.

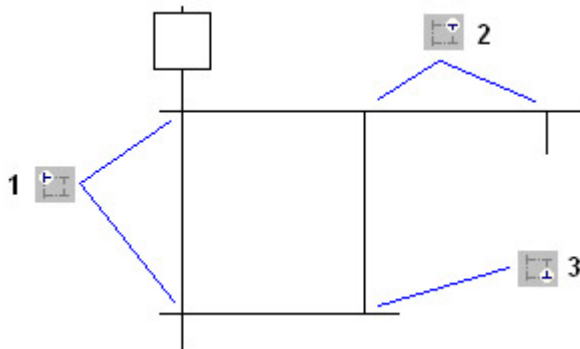

5.6.15.2.1 Simple or Double Divergence Lines

You can change the drawing of a divergence or convergence horizontal line, for drawing simple or double lines according to the SFC definition.

Move the selection on the main corner (on the left) and press the **Spacebar**.

5.6.15.3 View SFC Charts

The chart is entered in a logical grid. All objects are snapped to the grid.

- The (x,y) coordinates of the mouse cursor are in the status bar.
 - This helps locate errors detected by the compiler or to align objects in the chart.
- Zoom in or out of the edited diagram using the Ctrl + mouse-wheel operation.
- Press the [+] and [-] keys of the numerical keypad to zoom the diagram in or out.
- Drag the separation lines in vertical and horizontal rulers to resize the cells of the grid:

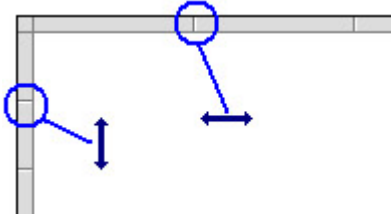

The SFC Editor adjusts the size of the font according to the zoom ratio.

When a cell is wide enough, a text is displayed with the contents of the step or transition (level 2).

Icon	Description
	Swap between possible overviews of level 2 in the level 1 chart: <ul style="list-style-type: none"> • Display code of actions and conditions. • Display notes attached to steps and transitions.

5.6.15.4 Move or Copy SFC Charts

The SFC Editor fully supports drag-and-drop for moving or copying items.

Move an Item

To move an item, select the item and drag it to its new position.

Copy an Item

To copy an item, select the item, press the **Ctrl** key, and drag it to its new position.

- It is also possible to drag pieces of a chart from one program to another if both are open and visible on the screen.
- At any moment, while dragging items, press **Esc** to cancel the operation.
- Alternatively, use the Copy / Cut / Paste commands from the Edit menu.
 - The Paste action is performed at the current position.

5.6.15.5 Renumber Steps and Transitions

Each step or transition is identified by a number.

- A jump to a step is identified by the number of the destination step.
 - The SFC Editor allocates a new number to each step or transition inserted in the chart.

Select a step, transition, or jump and press **Ctrl+ENTER** to change its number.

- It is not possible to change the number of a step or a transition if its level 2 is currently open for editing.
 - The number is used for identifying the step or transition in the level 2 editing window.

- In compiler reports:
 - A step is identified by its number prefixed by GS.
 - A transition is identified by its number prefixed by GT.

5.6.15.6 Enter Actions of a Step

Actions and [notes](#) attached to a step (level 2) are entered in a separate window.

To open the level 2 editing window of a step or transition, double-click its symbol in the chart or select it and press ENTER.

The level 2 editing window has these views for entering different types of level 2 information:

- Simple actions entered as text.
- P1 actions than can be programmed in ST/IL text, FFLD, or FBD.
- N actions than can be programmed in ST/IL text, FFLD, or FBD.
- P0 actions than can be programmed in ST/IL text, FFLD, or FBD.
- Text notes.

Use the tab buttons in the level 2 editing window to select a view:

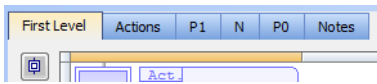

Figure 5-11: Editing window - Tabs

When editing P1, N, or P0 actions, use the radio buttons to select the programming language.

- The first view (Action) contains all simple actions for controlling a Boolean variable or a child SFC chart.
- It is possible to directly enter action blocks programmed in ST together with other actions in this view.
- Use this syntax for entering ST action blocks in the first pane:
 - Where *qualifier* is P1, N, or P0.

```
ACTION ( qualifier ) :
    statements...
END_ACTION;
```

5.6.15.7 Enter the Condition of a Transition

The conditions and [notes](#) attached to a transition (level 2) are entered in a separate window.

To open the level 2 editing window of a step or transition, double-click its symbol in the chart or select it and press ENTER.

The level 2 editing window has two views for entering different types of level 2 information:

- Condition programmed in ST / IL text or FFLD.
- Text notes.

Use the tab buttons in the level 2 editing window for selecting a view:



When editing the condition, use the **Edit / Set Language** menu command to select the programming language.

- This command is not available if the condition is not empty.
- FBD cannot be used to program a condition.

5.6.15.8 Enter Notes for Steps and Transitions

The SFC editor supports the definition of text notes for each step and transition.

The notes are entered in the level 2 editing window of steps and transitions.

See these topics for more information about the level 2 editing window:

- "Enter Actions of a Step" (→ p. 298)
- "Enter the Condition of a Transition" (→ p. 298)

Notes can be displayed in the chart.

- Notes have no meaning for the execution of the chart.
- Entering notes for steps and transitions enhances the auto-documentation of your programs.
- It provides a way to write and exchange specifications of an SFC program before actions and conditions are programmed.

5.6.16 Structured Text (ST) / Instruction List (IL) Editor

The ST / IL editor is a language-sensitive text editor dedicated to IEC 61131-3 languages.

The editor supports advanced graphic features such as drag-and-drop, syntax coloring, and active tooltips for efficient input and test of programs in ST and IL.

```
Blinker (TRUE, t#2s);
Trigger (Blinker.Q);

bSig := Trigger.Q;

Counter (
  bSig,          (* blinking input *)
  not bCommand, (* reset the counter if command *)
  255
);
iValue := Counter.CV;
```

Related Sections

- "Auto-completion of Words" (→ p. 301)
- "Bookmarks" (→ p. 269)
- "Read the Output of a MC Function Block in ST" (→ p. 302)
- "Select Variables and Instances" (→ p. 271)
- Select function blocks
- "ST / IL Drag-and-Drop" (→ p. 302)
- "ST / IL Language Selection" (→ p. 299)
- "ST / IL Syntax Coloring" (→ p. 299)
- Tooltips in the ST / IL Editor

TIP

Press <Ctrl + Spacebar> to open the [Variable Editor](#) dialog box.

5.6.16.1 ST / IL Language Selection

The KAS-IDE allows you to mix IL Language and ST Language in a textual program.

- ST Language is the default.
- When you enter IL Language instructions, the program must be entered between BEGIN_IL and END_IL keywords.

IL Language Example

```
BEGIN_IL
  FFLD   var1
  ST     var2
END_IL
```

5.6.16.2 ST / IL Syntax Coloring

The ST / IL editor supports syntax coloring according to the selected programming language (ST or IL).

The editor uses different colors for these kinds of words:

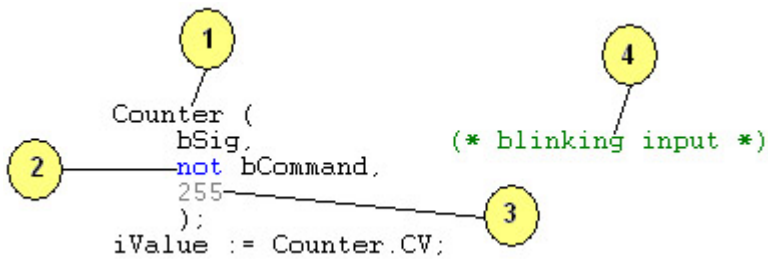

1. Default (identifiers, separators).
2. Reserved keywords of the language.
3. Constant expressions.
4. Comments.

TIP

Reserved words such as function names are blue.
Subprograms, including Kollmorgen UDFBs, are not reserved and show as black.

5.6.16.3 Intellisense

The following features are available with Intellisense in ST and FBD programs:

NOTE

They do not apply to actions in an SFC step.

Conditional compiling coloring

Parts of conditional compiling code (declared with [#ifdef](#) pragmas) that are not validated are grayed

```
#define CONDITION

#ifdef CONDITION

if tryGetSpike = true then
  MachineState := 2;
  MachineSpeed := 2000;
end_if;

#else

Printf('Manual mode', 0, 0, 0, 0);

// Start motion
MLMstRun(PipeNetwork.Master, TravelSpeed);

#endif
```

Commenting the CONDITION changes the active part of the program

```

// #define CONDITION

#ifndef CONDITION

if tryGetSpike = true then
    MachineState := 2;
    MachineSpeed := 2000;
end_if;

#else

Printf('Manual mode', 0, 0, 0, 0);

// Start motion
MLMstRun(PipeNetwork.Master, TravelSpeed);

#endif

```

NOTE

Save your project to have the code with the correct colors.

Auto-indentation

Lines are automatically indented on the left when you enter structured ST statements

Autocompletion**5.6.16.4 Auto-completion of Words**

The ST / IL editor includes commands for automatic completion of typed words according to declared variables and data types.

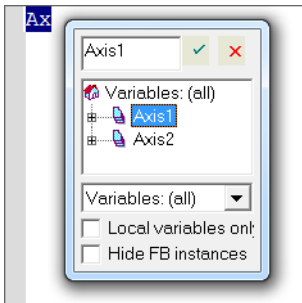

Press **Ctrl + Space** or **Ctrl + J** to activate auto-completion.

- If you use auto-complete and there is no match for a variable name in the Dictionary, press **ENTER** to open the variable creation dialog box.
- Use the dialog box to define a new variable.

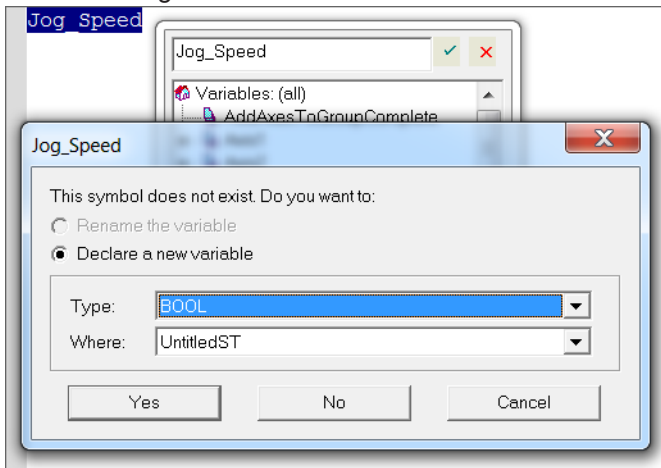

These features are available:

Auto-completion of:	Action
Variable Name	<ul style="list-style-type: none"> If you enter the first letters of a variable name, you can press <Ctrl+J> to automatically complete the name. A pop-up list opens with possible choices if several declared variable names match the typed characters.
FB Member	<p>Type the name of a function block instance (used either as an instance or a data structure).</p> <p>Press the point (.) after the name of the instance; a pop-up list opens with the names of possible members.</p>

5.6.16.4.1 Other Syntax-related Commands

When lines are selected, you can automatically indent them.

Press <Tab> or <Shift+Tab> to shift the lines to the left or right, by adding or removing blank characters on the left.

5.6.16.5 ST / IL Drag-and-Drop

The ST / IL Editor supports drag-and-drop to develop and test programs.

You can:

- Drag text (words or lines) from the ST / IL editor to another application (e.g., a text editor).
 - Do the opposite.
- Drag a variable symbol from the variable editor to the ST / IL editor.
- Drag a variable symbol from the ST / IL editor to the watch list.
 - When dragging the symbol of an array to the watch list, all items in the array are added to the watch list.

5.6.16.6 Read the Output of a MC Function Block in ST

In this example:

```
A6_Inst_MC_MoveRelative( 1, Axis6, -90, 5, 300000, 300000, 0, 0 );
```

- A6_Inst_MC_MoveRelative is an instance of MC_MoveRelative PLCopen Motion function block.
- The values given in parenthesis correspond to the 8 inputs of this FB.

The syntax to read one of the outputs in ST for this instance is:

```
<FUNCTION BLOCK NAME>.<OUTPUT>
```

This FB has these 5 outputs: Busy, Active, CommandAborted, Error, and Error ID (e.g., the **Active** output has this ST expression: A6_Inst_MC_MoveRelative.**Active**).

5.6.16.6.1.1 Example 1

```
UserVariable1 := A6_Inst_MC_MoveRelative.Error ;
```

5.6.16.6.2.2 Example 2

```
IF A6_Inst_MC_MoveRelative.Active THEN
UserVariable2 := 1 ;
ELSE
```

```
UserVariable2 := 0 ;
END_IF;
```

5.7 Create Variables

TIP

It is recommended to use the initial to reflect the variable type (e.g., Boolean with **b**; long integer with **L**) as a naming convention for variables.

5.7.1 Use the Dictionary

For explanations on dictionary usage, including how to create and "Rename Variables" (→ p. 95) see click here....

5.7.2 Create Variables from the Editors

Create variables directly from the IEC 61131-3 editors:

FBD editor

1. Click the dedicated button

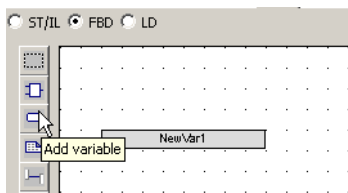

Figure 5-12: Add Variable in FBD Editor

2. Click a location in the editor (or double-click the variable if it is already created).
3. Edit the name in the [Variable Editor](#) (or select an existing variable within the list which is already filtered according to their relevant data type).

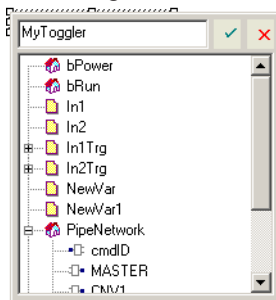

Figure 5-13: Define Variable Name in FBD Editor

4. The KAS-IDE automatically checks if the variable already exists. If it is new, you have to:
 - Select its type in the drop-down menu: for FBD and FFLD, it is set by default according to the In or Out data type of the function block
 - Specify where it is defined: the default is the current PLC program, but you can choose to make the variable Global or declared as a retain variable



Figure 5-14: Define Variable Type in FBD Editor

See "FBD Variables" (→ p. 278) for more information.

FFLD editor

1. Double-click the in or out pins of the function block

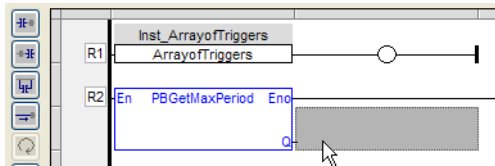

Figure 5-15: Add a Variable in the FFLD Editor

2. Edit the name (or select an existing variable within the list which is already filtered according to their relevant data type)

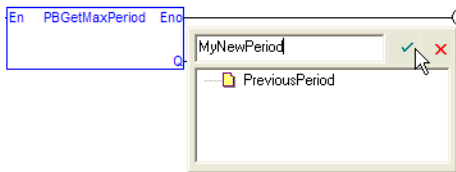

Figure 5-16: Define a Variable Name in the FFLD Editor

3. The KAS-IDE automatically checks if the variable already exists. If it is new, you have to:
 - Select its type in the drop-down menu (by default, it is set according to the In or Out data type of the function block)
 - Specify where it is defined

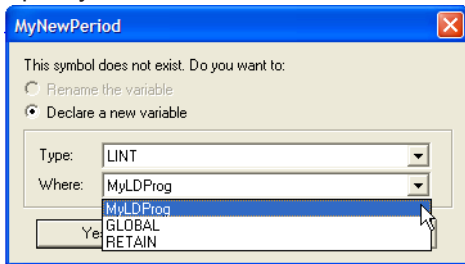

Figure 5-17: Define a Variable Type in the FFLD Editor

5.7.3 Data Types

You can create a variable of available Data Types.

How to declare an array?

1. Double-click in the corresponding cell of the variable editor (i.e. the **Dim.** column)
2. Enter its dimension (**Note:** for a multi-dimension array, enter dimensions separated by commas (ex: 2,10,4))

Name	Type	Dim.	Attrib.
NewVar	BOOL		
MachineLogic		2,10,4	
NewVar	BOOL	[0..1,0..9,0..3]	

Figure 5-18: Declare an Array for an Internal Variable

also see "Arrays" on page 703

5.7.4 Complex Structures

Complex variables are arrays, structures, and instances of function blocks. The following features are allowed for programming:

- Use arrays of structures
- Use arrays of FB instances
- Pass any complex data (array, structure, instance) to a UDFB or sub-program

There is almost no limitation in the amount of complex data declared (theoretically up to 4GB, but practically limited by the memory available in the runtime)

For more explanations on the **Structure** concept, refer to (→ # 703, Structure)

5.7.4.1 Declare the Structure

1. Right-click in the Dictionary to open the menu.
2. Select the **Add structure** command.

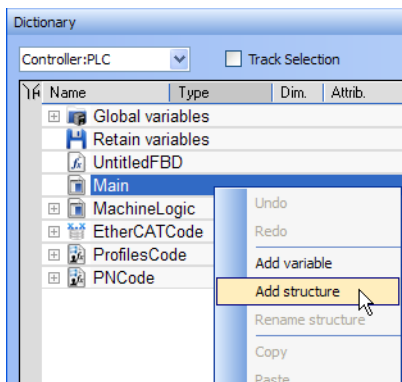

Figure 5-19: Add Structure

3. Right-click on the new structure and select the **Rename structure** command.

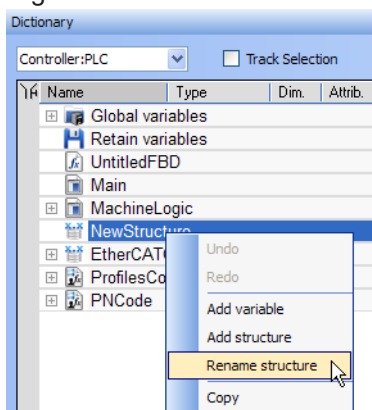

Figure 5-20: Rename Structure

- Right-click on the new structure and select the **Add variable** command.

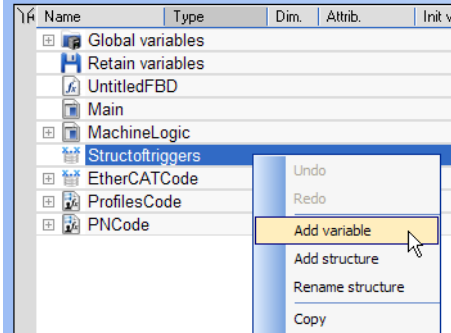
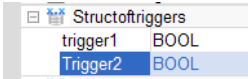

Figure 5-21: Add Variable

- Expand the new structure.
- Double-click on the new nested variable and define its name and type.



- Repeat steps 5 and 6 to add all the requested variables.

5.7.4.2 Create an Instance of the Structure

When finalized, drag-and-drop the structure from the library in the **(Project)** node to a program. A new instance is automatically created.

- Select the new structure and move it with a drag-and-drop operation to the program declaration in the Dictionary.

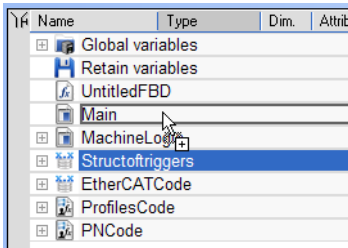
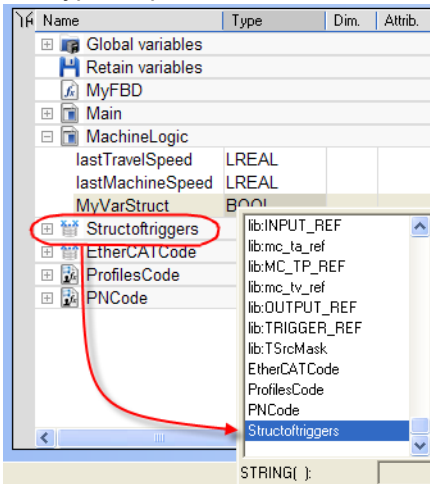

Figure 5-22: Create an Instance of the Structure

- You can also add a variable in the Dictionary with the **Add variable** command. Then double-click on the new variable to define its type by selecting the structure type which is displayed in the Type drop-down menu.



- Then you can drag this new instance and drop it in your program like any other variable

5.7.5 Variable Editor

You can edit variables directly from each IEC 61131-3 editor.

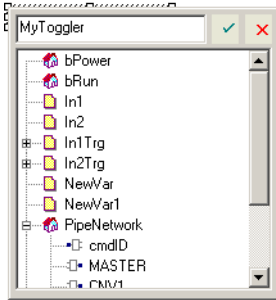

Figure 5-23: Edit the Name in the Variable Editor

TIP

Ctrl + Spacebar opens this dialog box

KAS-IDE automatically checks if the variable already exists. When the variable is new, you have to:

- Select its type in the drop-down menu: for FBD and FFLD, it is set by default according to the In or Out data type of the function block
- Specify where it is defined: the default is the current PLC program, but you can choose to make the variable Global or declared as a retain variable

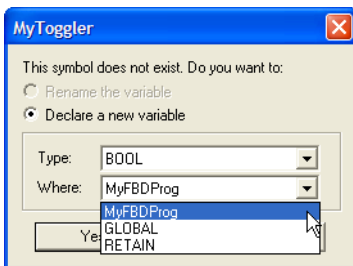

Figure 5-24: Define Type and Scope of the Variable

5.7.6 Edit Variables as Text

Variables can be edited as text.

- Text editing applies to all the variables of a group.
- Select **Edit variables as text** from the right-click menu to open a dialog box with all of the variables in the group.
 - From here, variables may be added, deleted, or edited using the IEC 61131-3 format.

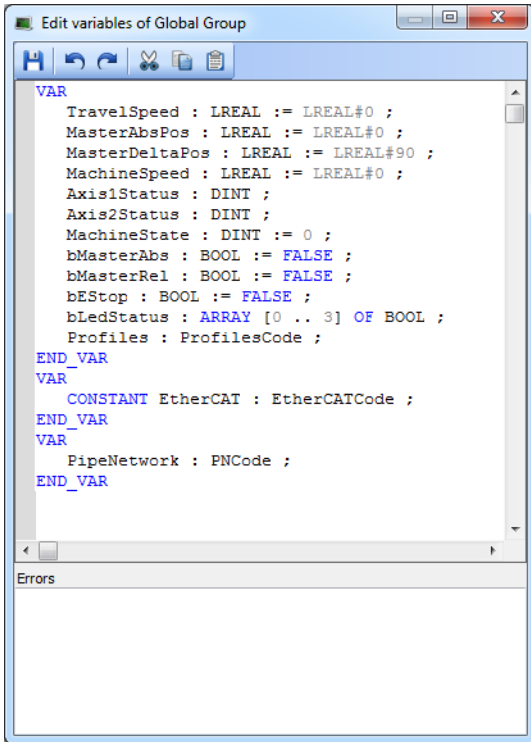

Figure 5-25: Edit Variables as text

The editing dialog contains the basic text-editing functions: Save, Undo, Redo, Cut, Copy, and Paste.

- When changes are saved, the variables are validated.
- If there are errors in the declaration, the changes are not saved and errors are listed in the "Errors" section of the dialog box.

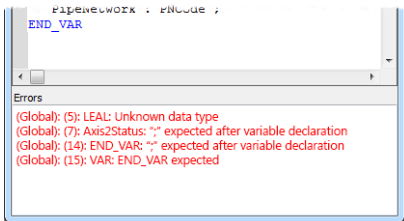

Figure 5-26: Errors caused by editing variables.

Each error includes the group name, the line number where the error occurs, and what the error is.

Double-click an entry to place the cursor at the point of the error.

ⓘ IMPORTANT

If variables that are used in PDO mapping are renamed or deleted, the mapping is lost when the changes are saved.

If this occurs, an alert appears.

See "Edit Variables as Text using IEC 61131-3 Syntax" (→ p. 97) for more information about editing variables as text.

5.8 Create Functions and Function Blocks

For explanation about the difference between functions and function blocks, refer to "Program Organization Units" (→ p. 714).

5.8.1 Declare Functions or Function Blocks

This section explains how to create a new function or UDFB.

1. Expand the PLC node in the Project Explorer, and right-click on the "Subprograms" (→ p. 76) item and select the action you wish to perform (i.e., *New Function* or *New UDFB*). The New Program dialog box will open.

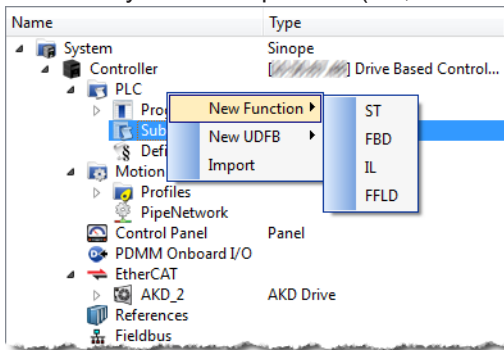

2. Enter the program name (MyFBD, for example), and click OK.

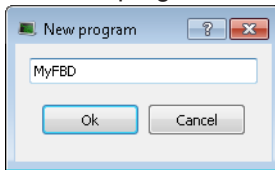

3. The *Program Properties* dialog box opens. This is where you will enter the input and output parameters for the function or UDFB.

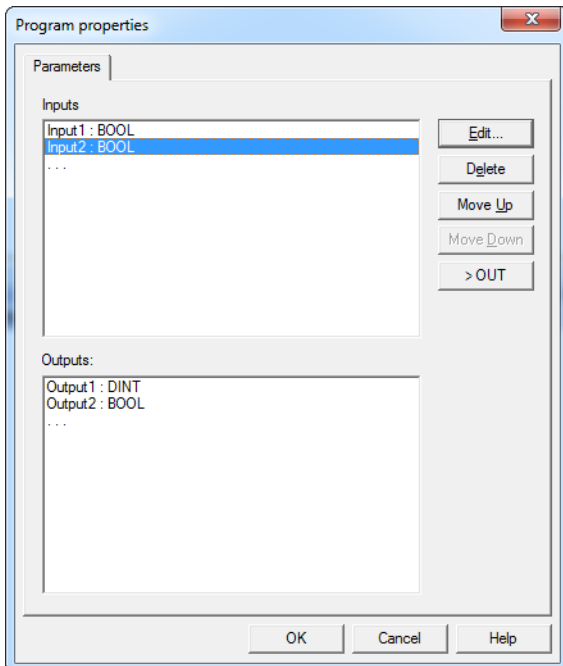

4. Click in the editable space ("...") in Inputs or Outputs enables the **Edit** button. Click the Edit button or double-clicking on the editable space opens the Parameters dialog which lets you add variables for Inputs and Outputs.

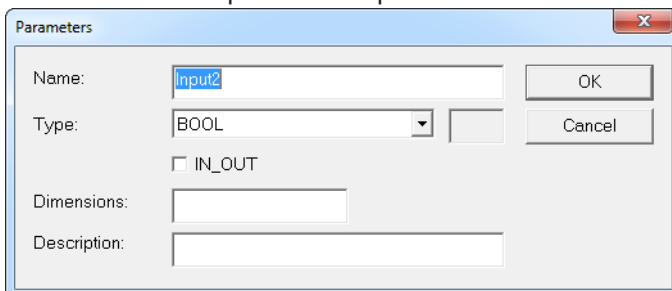

Item	Description
Edit	Click this button to change the definition of the selected parameter. When the last line (...) of the list is selected, click this button to a new parameter.
Delete	Click this button to remove the selected parameter.
Move Up/Down	Click these buttons to move the selected parameter in the list to arrange the order of parameters. The order is very important as it defines the calling prototype of the UDFB or sub-program.
Swap	Click this button to move the selected parameter between the Inputs and Outputs lists. When an button is selected the button's text changes to show where the parameter is moved.

NOTE

New UDFBs are added to the **(Project)** node in the [Library toolbox](#)

5.8.2 Define Parameters and Private Variables

For a Function or UDFB, input and output parameters (as well as private variables) are declared in the Dictionary toolbox as local variables of the item. The **Add variable** command let you add the following:

- **Input¹** Parameter
- **Output²** Parameter
- **Private³** Variable

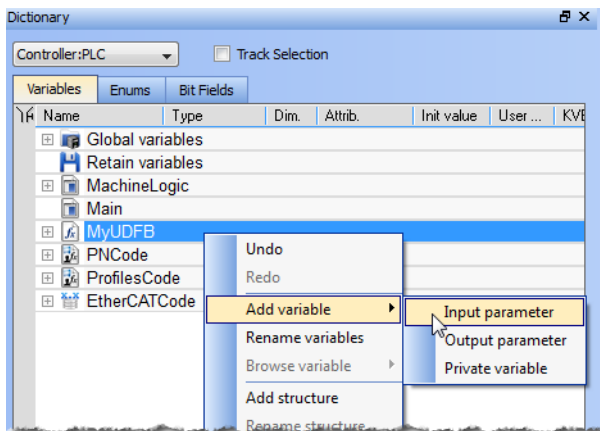

Figure 5-27: Parameters and Private Variables

Input and Output parameters always appear at the beginning of a UDFB group.

Pressing the **INSERT** key when the item is selected adds a private variable.

NOTE

There are some things to be aware of with UDFB parameters:

- UDFB cannot contain parameters being both for Input and Output
- Simple parameters (scalar type) can be either IN, OUT, or IN_OUT

¹Externally supplied, not modifiable within the organization unit

²Supplied by the organization unit to external entities

³Supplied by external entities - can be modified within organization unit

- Complex parameters (an array or structure) should be declared as IN but is systemically considered to be IN_OUT.
- UDFB cannot have more than 32 input parameters or 32 output parameters
- Output parameters can only be simple [data type](#)

5.8.3 Finalize Functions or Function Blocks

Double-click the item in the Project Explorer to open and complete it in its corresponding editor.

5.8.4 Call Functions or Function Blocks

When finalized, you can drag-and-drop UDFBs from the library in the **(Project)** node to a program just like any other function block. A new instance is automatically created.

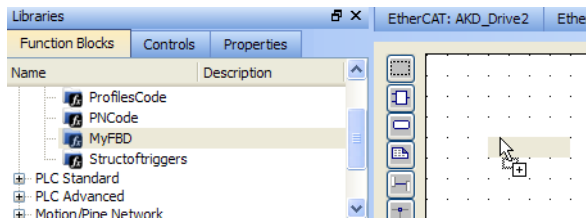

Figure 5-28: Create an Instance of UDFB in a Program

NOTE

- A single data type parameter defined as IN is passed by the calling program to the UDFB and the body UDFB cannot change its value
- A single data type parameter defined as OUT is set in the body UDFB and always actuated in the calling program after the call
- A parameter which is an array or a structure is always declared as IN (visible on the left of the block). Both the calling program and the body of the UDFB can read and write such a parameter

5.9 Use the Defines List

The **Defines** list consists of defined constants, (an expression with a fixed value).

- **Defines** are:
 - Both pre-defined (internal) and user-created (global and local).
 - Used to determine which parts of a program's code are compiled using an `ifdef` statement.
 - See "Conditional Compiling" (→ p. 223) for more information.
 - This creates more efficient code for a given machine type.
 - Example: You can write a program that covers many machine types but compile for a specific machine with more efficient code.

Defined constants have these levels of scope:

Level	Scope
"Internal Defines" (→ p. 312)	All the projects present on your machine.
"Global Defines" (→ p. 313)	All the programs in your project. These are user-defined.
"Local Definitions" (→ p. 313)	Only the current program currently open.

ⓘ IMPORTANT

Pay special attention to the "Data Types" (→ p. 702) of variables used in the expression to guarantee precision

ⓘ IMPORTANT The precision of the expression.

Example: When mixing **LREAL** and **REAL**, the precision is that of **REAL**.

KAS-IDE supports "Alias Definitions" (→ p. 719).

5.9.1 Internal Defines

These are the pre-defined, common constant definitions declared for all projects.

ⓘ IMPORTANT

Do **not** modify these declarations.
This is to maintain consistency.

To see the set of currently installed declarations, view the file (named: `lib.eqv`) located here:
C:\Program Files (x86)\Kollmorgen\Kollmorgen Automation Suite [version number]\Astrolabe\Bin\HwDef.

NOTE

The folder location is different if another location was chosen when installing KAS.

5.9.1.1 Example: Pre-defined Constants

This is an example of pre-defined constants that may be in the system.

```
#define MLPN_CREATE_OBJECTS 1 (* Creation of blocks and pipes *)
#define MLPN_ACTIVATE 2 (*Activation of pipes*)
#define MLPN_CONNECT 3 (*Connections from convertors to axes*)
#define MLPN_POWER_ON 4 (*Power ON of axes*)
#define MLPN_POWER_OFF 5 (*Power OFF of axes*)
#define MLPN_DEACTIVATE 6 (*Deactivation of pipes*)

#define MLSTATUS_NOT_INITIALISED 0 (*Motion not initialized*)
#define MLSTATUS_RUNNING 1 (*Motion is running*)
#define MLSTATUS_STOPPED 2 (*Motion is stopped*)
#define MLSTATUS_ERROR 3 (*Motion is in error*)
#define MLSTATUS_INITIALISED 2 (*--DEPRECATED-- Motion is initialised*)

#define MLPR_CREATE_PROFILES 1 (* Creation and initialization of profiles *)

#define MLFI_FIRST 0 (* ID of the first FastInput of an axis *)
#define MLFI_SECOND 1 (* ID of the second FastInput of an axis *)

#define MLFI_DISABLE 0 (* configures a FastInput as disabled *)
#define MLFI_RISING_EDGE 1 (* FastInput is sensible to rising edges *)
#define MLFI_FALLING_EDGE 2 (* FastInput is sensible to falling edges *)

#define PI 3.1415926535897932

#define EC_POSITION_DEMAND_VALUE 10000
#define EC_VELOCITY_DEMAND_VALUE 10001
#define EC_TORQUE_DEMAND_VALUE 10002
#define EC_ADDITIVE_TORQUE_VALUE 10003
#define EC_MAX_TORQUE 10004
#define EC_OPERATION_MODE 10005
```



```
#define EC_CONTROL_WORD          10006
#define EC_LATCH_CONTROL_WORD    10007
#define EC_ANALOG_OUTPUT         10009
```

NOTE

The exact contents of the list depends on the version of the KAS-IDE.

5.9.2 Global Defines

Global Defines are user-generated constants used in a program.

Global Defines are used to write code and add an `ifdef` statement to call the Define only if it is used for a particular machine.

They are created and edited in the Project Explorer toolbox under **PLC**.

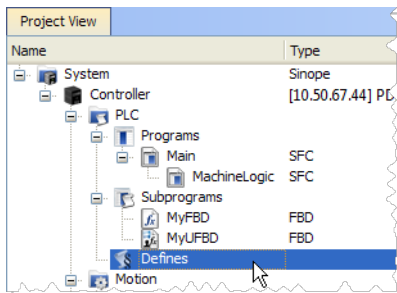

Figure 5-29: Global Defines

Double-click the **Defines** item to open the global definitions file (named: `appli.eqv`) in a text editor as:

```
#define DefReqTime T#10ms // 10 ms
#define BitMask 2#00100111 // binary
#define BitMaskHex 16#12AE // hexadecimal

#define OFF FALSE (* redefinition of FALSE constant *)
#define PI 3.14 (* numerical constant *)
#define ALARM (bLevel > 100) (* complex expression *)
```

Figure 5-30: Edit the Global Definitions

Each definition must be entered on one line of text using this syntax:

```
#define Identifier Equivalence (* comments *)
```

5.9.2.0.1 Definition Inside Another Definition

A definition within the contents of another definition is allowed.

The definition used in the second must be declared first.

Example:

```
#define PI 3.14
#define TWOPI (PI * 2.0)
```

5.9.2.1 Local Definitions

Local definitions are user-created defines used within the corresponding program through an `ifdef` statement.

TIP

Using definitions disturbs the program monitoring and makes error reports more complex. It is recommended to restrict the use of definitions to simple expressions. This helps avoid misunderstandings when reading or debugging a program.

5.10 Map Input and Output to Variables

This procedure describes how to map EtherCAT motion bus I/O or AKD PDMM/PCMM Onboard I/O to PLC variables.

NOTE

This operation is disabled when the controller is running.

For more information see:

- "Map I/O from the Project Explorer" (→ p. 337)
- "PLC Variable Creation Wizard" (→ p. 317)
- "PLC Variable Selector" (→ p. 318)
- "Analog I/O Parameters" (→ p. 320)

5.10.1 Map I/O from the Project Explorer

TIP

For information on mapping I/O with third-party devices, see the "PDO Selection/Mapping tab" (→ p. 340).

1. In the Project Explorer, expand the Controller node and the EtherCAT nodes to access your devices.

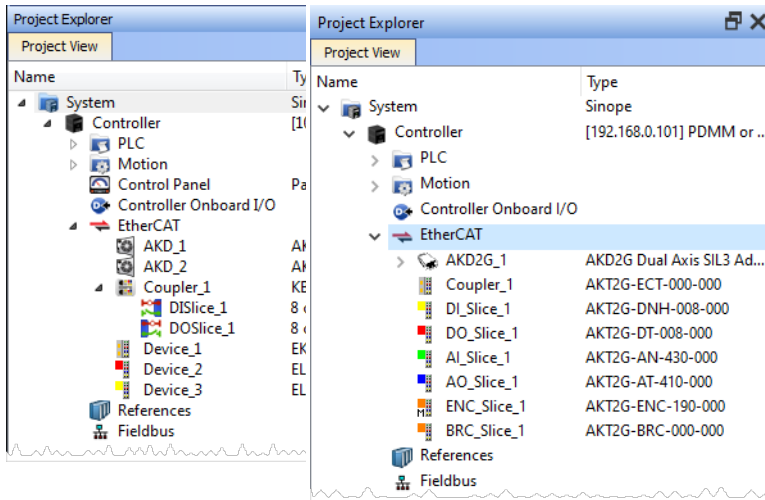

AKT (K-Bus) devices AKT2G (E-Bus) devices

2. Accessing the device properties is slightly different depending upon the device.

AKD or AKD2G

Double-click the drive and select the **I/O** tab.

**AKD PDMM or PCMM**

Double-click Controller Onboard I/O.

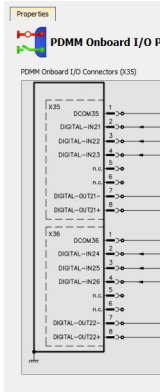
**I/O Slice**

Double-click the I/O Slice under EtherCAT (E-Bus) or in the Coupler entry (K-Bus).

For Slice Analog I/O and thermocouples, the offset and gain parameters must be defined.

Safety I/O Slice

Double-click the Safety I/O Slice under EtherCAT (E-Bus).

Safe Digital Inputs and Output channels are clearly identifiable by a yellow table in the **I/O** tab.

Digital output logic on the safety slices / devices is typically disabled by default from the standard PLC.

See the Description of Safety Parameters and the AKT2G-IO-SDO-004-000 Safety Terminal with Four Digital Fail-safe Outputs table for details.

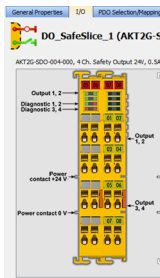

3. There are several ways to map variables:

- Drag and drop a variable from the Dictionary onto a table entry.
- Use the "PLC Variable Creation Wizard" (→ p. 317) for Kollmorgen devices.
- Directly map/unmap the Inputs/Outputs to PLC variables using the "PLC Variable Selector" (→ p. 318).

Select the channel(s) to map. Selection may be done by click-dragging or shift-clicking a range of entries. The entire table may be selected by clicking on its border.

After the selection is made, right-click and select **Map** or press the **Enter** key. This opens the "PLC Variable Selector" (→ p. 318).

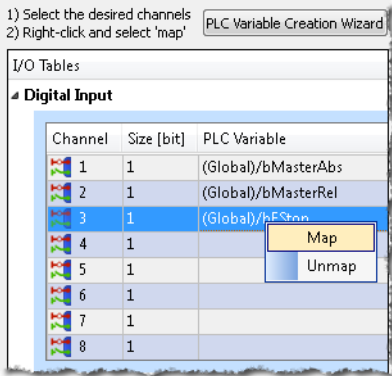

TIP

The **Unmap** command in the contextual menu is used to remove the link between the variable and the associated channel(s). In addition, deleting a variable from the dictionary which is mapped to the channel(s) also removes the link(s).

Choose the variable to be linked to the channel(s) or PDO object.

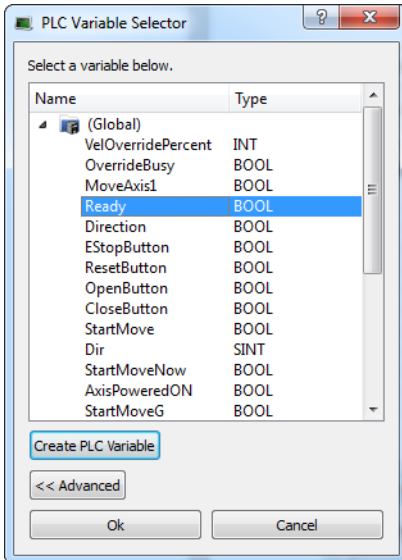

NOTE

The list of variables is filtered to display only those with relevant types.

- PLC Variable Selector displays Read Only variables when mapping the Input channels from the I/O tab.
- Variables assigned to the Safe Digital Input and Safe Digital Output channels must be Read Only.

IMPORTANT

The limitations of PLC variable mapping are:

- Each PLC variable can be mapped to an EtherCAT I/O and exclusively to either:
 - a Controller Onboard I/O.
 - an external driver.
- Because a variable can only be mapped to one channel or PDO object, when you link a variable to a new channel or PDO object, the previous mapping is removed (even if linked to another slice or device).
- Individual bits within a variable can be mapped to multiple I/O channels on different devices (AKD, AKD PDMM, PCMM, or Slice).

Example: The same PLC variable cannot be mapped to both Profinet and a Controller Onboard I/O but it is possible with a regular EtherCAT I/O.

What happens to variables that are mapped to a device I/O which was removed using the ECATDeviceAction function block?

When a device is removed using ECATDeviceAction:

- **Variable mapped to an Analog or Digital Input Type**
 - The value of the variable becomes '0' when the mapped device is removed.
 - The device I/O value is automatically reconnected to the variable when the device is reconnected to the network.
- **Variable mapped to an Analog or Digital Output**
 - The value is not sent to the device when the mapped device is removed.
 - When the device is reconnected, the value is sent to the I/O automatically.

What happens to the PLC variables which are mapped to the X22 Connector I/Os of an AKD2G if the drive is replaced with a single-axis AKD2G which does not have an X22 Connector?

All of the I/Os mapped to the X22 connector are grayed out in the IO tab:

NOTE

AKD2G drives are available with various I/O options. An AKD2G drive of one variant can be replaced in the KAS project with a drive that has a different I/O option. See the **AKD2G Model Nomenclature** section in [Automation and Motion Control Programmable Automation Solutions](#) for available models and I/O options.

See Also:

- "PLC Variable Selector" (→ p. 318) for information about the **Create PLC Variable** and **Advanced** buttons.
- "Analog I/O Parameters" (→ p. 320) for information about parameters.
- "Configure Onboard I/O" (→ p. 194) for information about the AKD Onboard EtherCAT I/Os.
- "Controller Onboard I/O" (→ p. 398) for information about the AKD PDMM or PCMM local digital I/Os.

5.10.2 PLC Variable Creation Wizard

This wizard allows you to automatically create a list of variables used for the mapping. The variable type is **Boolean** for digital I/Os and **UINT** for analog I/Os.

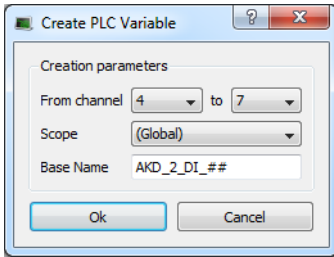

Figure 5-31: Wizard to Create PLC Variable - Parameters

Field	Description
From channel	Defines the range of channels you want to map automatically
Scope	Defines where the variables are created (if you select the Global scope, then the variables are created under the Global node in the Dictionary)
Base Name	Pattern used for variable naming with the name of the object in the Project Tree, followed by a 2-letter acronym (2LA) representing the I/O type. The channel number will replace ## .

Channel	Variable Name
1	
2	
3	
4	DInput_4
5	DInput_5
6	DInput_6
7	DInput_7
8	

Figure 5-32: Wizard to Create PLC Variable - Mapped Channels

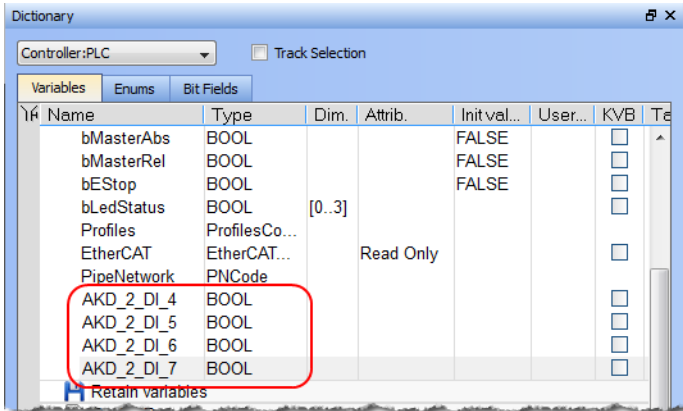
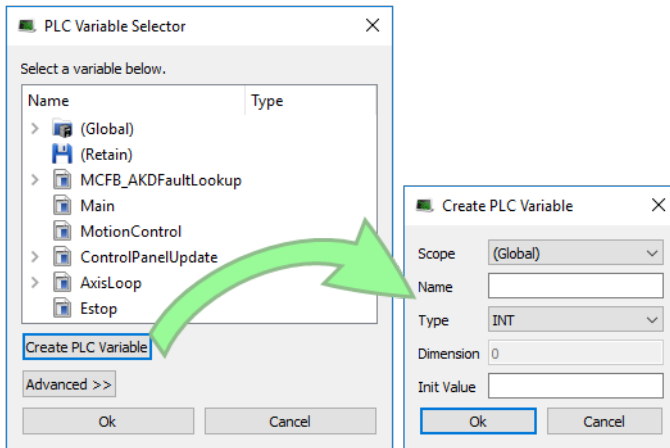

Figure 5-33: Wizard to Create PLC Variable - Variables in the Dictionary

5.10.3 PLC Variable Selector

5.10.3.1 Create PLC Variable Button

This button allows the creation of a new variable to be mapped to the selected item(s).



Field	Description
Scope	Defines where the variable is created
Name	See "Name a Variable" (→ p. 94)
Type	Defines the Type of the variable, and its Dimension if the variable is an array
Dimension	The dimension of the variable (read-only). The dimension is set automatically based on the necessary size and the selected variable type.
Init Value	See "Variable Initial Value" (→ p. 97)

Based on the variable **Type** we select, the KAS-IDE will automatically set the **Dimension** (the size of the array) and assign the bits across the objects.

See the [online help for a video](#) that demonstrates mapping a variable to several PDO objects.

TIP

- Safety PDOs are highlighted in yellow with a border.
- Any variable assigned to a FSoE PDO must be Read Only. See "About Safety, PDOs, and Variables" (→ p. 353) for more information.
- See "Set Up a Variable to Monitor Safety Data" (→ p. 344) for step-by-step instructions.

See also "Create Variables" (→ p. 303)

5.10.3.2 Advanced Button

For integer variables with types stored on several bits, the Advanced button gives access to the **Start bit** definition. This allows you to link a set of channels to a specific range of bits within an integer variable.

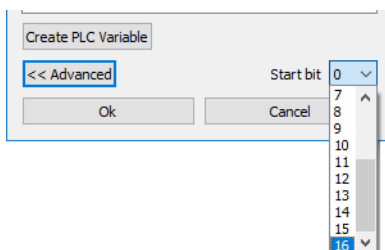

For example, when you select three channels ranging from 1 to 3 and map them to a DINT variable (stored on 32 bits ranging from 0 to 31), the first channel can be linked to position ranging from 0 to 29. The three channels are mapped to the last three bits ranging from 29 to 31.

1) Select the desired channels
2) Right-click and select 'map'

Channel	Variable Name
1	MachineState_29
2	MachineState_30
3	MachineState_31
4	DInput_4

NOTE

When the selected variable is an array, the “Start bit” is disabled. An offset is not allowed when mapping to an array.

5.10.4 Analog I/O Parameters

5.10.4.1 AKT2G Input Terminals

The offset and gain is applied to calculate the value converted from the analog input:

$$\text{PLC Variable Value} = \text{Analog to Digital Converter Value} \times \text{Gain} + \text{Offset}$$

Where the Gain and Offset are configured from the terminal's I/O tab.

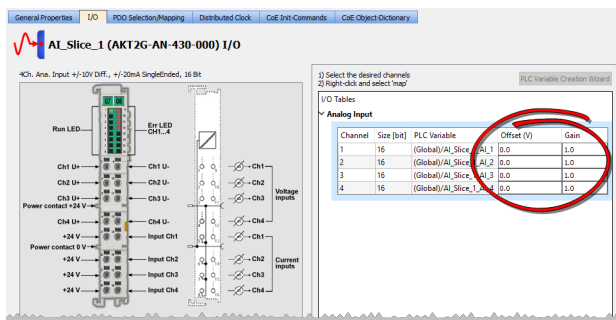

See E-Bus Analog I/O Data Representation for more information.

5.10.4.2 AKT2G Output Terminals

The offset and gain is applied to calculate the value to be converted to the analog output:

$$\text{Digital to Analog Converter Value} = \text{PLC Variable Value} \times \text{Gain} + \text{Offset}$$

Where the Gain and Offset are configured from the terminal's I/O tab.

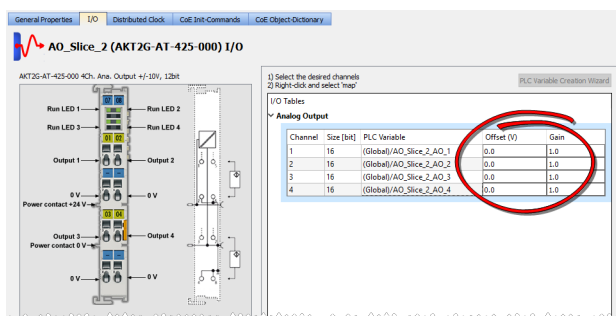

See E-Bus Analog I/O Data Representation for more information.

5.10.4.3 AKT Input Terminals

The process data that are transferred to the Bus Coupler are calculated using these equations:

$$Y_a = (B_a + X_{ADC}) \times A_a$$

$$Y_{out} = B_w + ((A_w + A_h) \times Y_a)$$

With these parameters:

Parameter	Description
X_{ADC}	Output values of the Analog Input Modules A/D converter.
Y_{out}	Process data to the controller.
B_a, A_a	Manufacturer offset and gain compensation ‡.
A_h	Manufacturer scaling: default gain ‡.
B_w, A_w	User scaling: Offset and Gain as set in the "Analog Input Properties" (→ p. 321).

‡ For the thermocouple input terminals, AKT-AN-200-000 and AKT-AN-400-000, the manufacturer default gain is 160.

For all other supported terminals, the manufacturer default gain is 1.

The manufacturer default offset is 0 (zero) for all supported terminals.

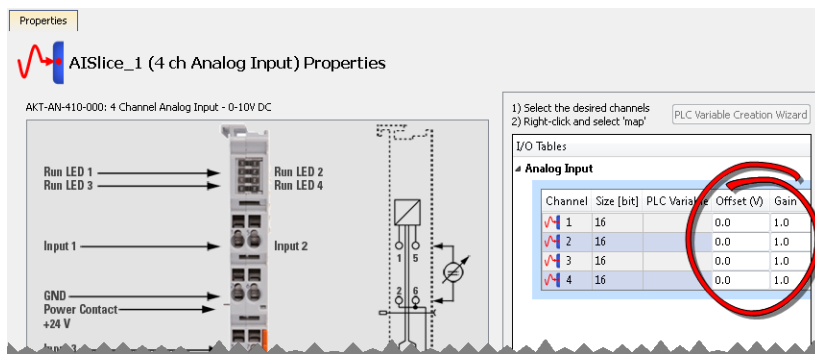

Figure 5-34: Analog Input Properties

5.10.4.4 AKT Output Terminals

The process data that are transferred to the Bus Coupler from the controller are calculated using these equations:

$$Y_2 = B_w + ((A_w \times A_h) \times X)$$

$$Y_{dac} = Y_2 \times A_a + B_a$$

With these parameters:

Parameter	Description
X	Controller Process data.
Y_{dac}	Controller data to analog output module D/A converter.
B_a, A_a	Manufacturer offset and gain compensation ‡.
A_h	Manufacturer scaling: default gain ‡.
B_w, A_w	User scaling: offset and gain as set in the "Analog Output Properties" (→ p. 322).

‡ The manufacturer default offset is zero for all supported terminals.
The manufacturer default gain is 1 for all supported terminals.

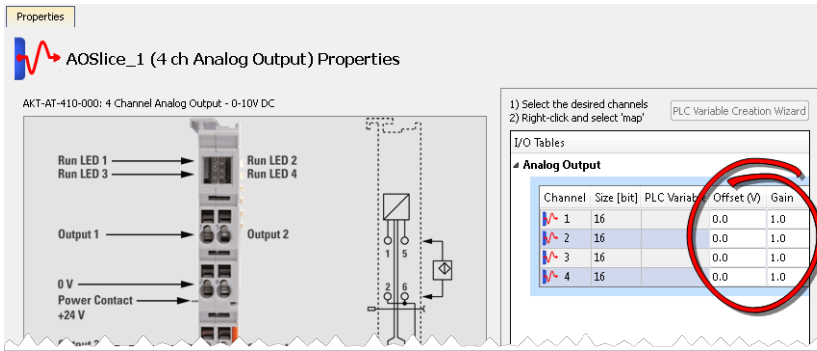
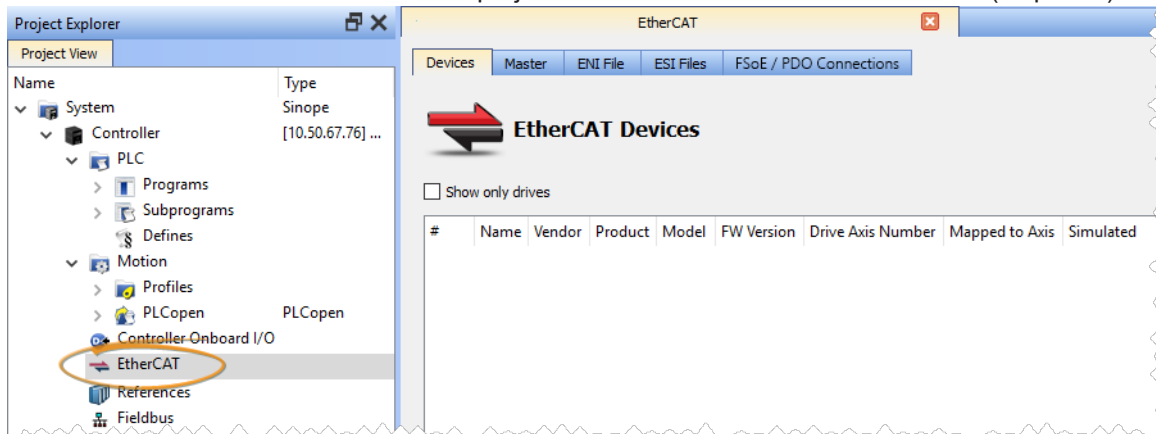

Figure 5-35: Analog Output Properties

5.11 Configuring EtherCAT

This section provides reference information for the EtherCAT entry in the Project Tree.

- Specifically this includes these tabs:
 - "EtherCAT Devices tab" (→ p. 322)
 - "EtherCAT Master Settings tab" (→ p. 327)
 - "ENI File tab" (→ p. 329)
 - "ESI Files tab" (→ p. 330)
 - "FSoE / PDO Connections tab" (→ p. 331)
- These are accessed by double-clicking on the EtherCAT item in the Project Tree or right-clicking and selecting **Properties**.
- Reference information for devices in the project can be found in "EtherCAT Devices" (→ p. 335).



5.11.1 EtherCAT Devices tab

The EtherCAT Devices tab lists all the EtherCAT devices and provides for the ability to discover and map their use.

- The interface is slightly different for AKD and AKD2G drives.
- The AKD2G prompts you to select the mapping by the drive axis.

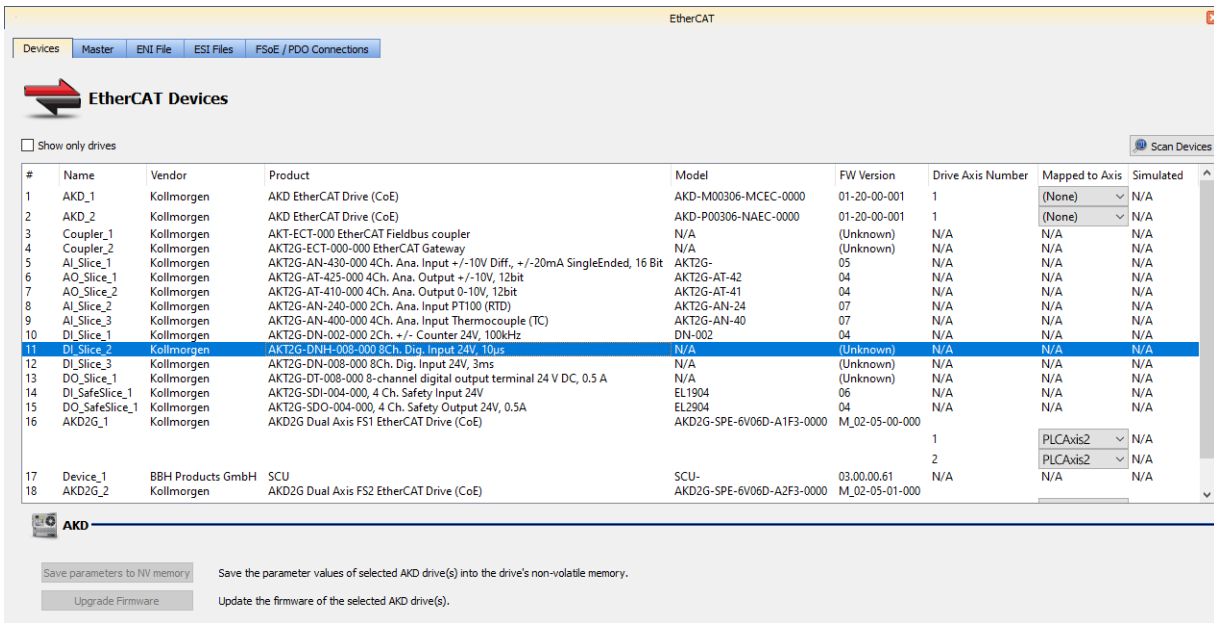

Figure 5-36: EtherCAT Devices Summary Form

First generation AKD drives support one axis per drive, while AKD2G drives support two axes per drive. When configuring drives in the "EtherCAT Devices tab" (→ p. 322), you need to designate which motion axis applies to each drive axis, which is the actual axis the drive controls.

EtherCAT Devices

Item	Description
Show only drives	This option hides all EtherCAT slaves from the list that are not drives.
Scan Devices	The KAS Runtime sends EtherCAT messages to discover the physical devices and modules present in the network. See "Scan Devices" (→ p. 325).
Name, Vendor, Product, and Model	<ul style="list-style-type: none"> The project device name, vendor name, product name (or code number), and model number for each device is displayed and ordered by the position in the tree. The model (when available) includes the extension and connectivity options (e.g., NBEC).

Item	Description
FW Version	<ul style="list-style-type: none"> • For Kollmorgen drives, the firmware version is displayed on the conditions that: <ul style="list-style-type: none"> • The “Scan Devices” routine was run successfully on the EtherCAT network (for drives with version 01-08-000-00 firmware or later) • Firmware was downloaded to the drive(s) while the KAS project was open in the KAS-IDE. • For other devices, the firmware version is displayed if the Scan Devices routine was successfully run and the device supports reading this information over EtherCAT (i.e., it uses CoE object 0x100A:0). • Otherwise (Unknown) is displayed. <div style="border: 1px solid black; padding: 5px; margin-top: 10px;"> <p style="text-align: center; margin: 0;">NOTE</p> <p>If a Kollmorgen drive is showing the firmware version as "Unknown", the drive has valid resident firmware (from which to boot), but does not have valid operational firmware. Download and install the latest operational firmware and reboot the AKD / AKD2G.</p> </div>
Drive Axis Number	<ul style="list-style-type: none"> • This number designates which axis, of those available on a drive, is being defined. • For most drives, this number is a "1", but for AKD2Gs, there are two entries: <ul style="list-style-type: none"> • Drive Axis Number 1 • Drive Axis Number 2
Mapped to Axis	<p>For each drive, it is displayed if it is:</p> <ul style="list-style-type: none"> • Unassigned: From the drop-down menu, choose an axis that has not been assigned. <ul style="list-style-type: none"> • It is applicable for either PLCopen or Pipe Network motion engines. • Already mapped to a physical device: The mapping operation is done using the Scan Devices command. <ul style="list-style-type: none"> • See details in "Scan Devices" (→ p. 325). • If a drive node is removed from the EtherCAT network using ECATDeviceAction, then the mapped axis (if any) is automatically forced to simulation.

Item	Description						
Simulated	<p>Used to simulate the device, which means that the device is not used and no communication to this device is performed through the fieldbus.</p> <p>When can drives can be simulated?</p> <table border="1" data-bbox="579 349 1339 884"> <thead> <tr> <th data-bbox="579 349 938 405">Mapped to an Axis?</th> <th data-bbox="943 349 1339 405">Simulated State</th> </tr> </thead> <tbody> <tr> <td data-bbox="579 412 938 495">No</td> <td data-bbox="943 412 1339 495">Simulation is not applicable</td> </tr> <tr> <td data-bbox="579 501 938 884">Yes</td> <td data-bbox="943 501 1339 884"> <ul style="list-style-type: none"> If the Drive is mapped to a physical drive, then the simulation is Enabled. <ul style="list-style-type: none"> Set the state to Yes/No --> Display checkbox. If Drive is not mapped to a physical drive, Simulation is forced to Yes. </td> </tr> </tbody> </table>	Mapped to an Axis?	Simulated State	No	Simulation is not applicable	Yes	<ul style="list-style-type: none"> If the Drive is mapped to a physical drive, then the simulation is Enabled. <ul style="list-style-type: none"> Set the state to Yes/No --> Display checkbox. If Drive is not mapped to a physical drive, Simulation is forced to Yes.
Mapped to an Axis?	Simulated State						
No	Simulation is not applicable						
Yes	<ul style="list-style-type: none"> If the Drive is mapped to a physical drive, then the simulation is Enabled. <ul style="list-style-type: none"> Set the state to Yes/No --> Display checkbox. If Drive is not mapped to a physical drive, Simulation is forced to Yes. 						
Save parameters to NV memory	<ul style="list-style-type: none"> Save the drives' parameters to the "NVRAM" (→ p. 691) of each drive currently selected in the list. <ul style="list-style-type: none"> This action is enabled only when the Online Mode is activated. You are automatically prompted to save modified drive parameters if this action has not been performed prior to these circumstances: <ul style="list-style-type: none"> Exiting "Online Configuration Mode" (→ p. 255). Disconnecting from the controller Closing the project Exiting the IDE 						
Upgrade Firmware	<ul style="list-style-type: none"> This command triggers a firmware upgrade for the selected drives. Use Ctrl+A shortcut to select all drives. For more details, see the FAQ "Setup" (→ p. 833) section. 						

5.11.1.1 Scan Devices

The scan process allows these tasks:

- Discover the devices and modules physically present in the fieldbus network.
 - See "EtherCAT Network - Physical View" (→ p. 326).
- Map them to items under the EtherCAT node of the Project Explorer
 - See "EtherCAT Network - Logical View" (→ p. 326).
- The order of the devices in the tree is the same as in the real fieldbus network.

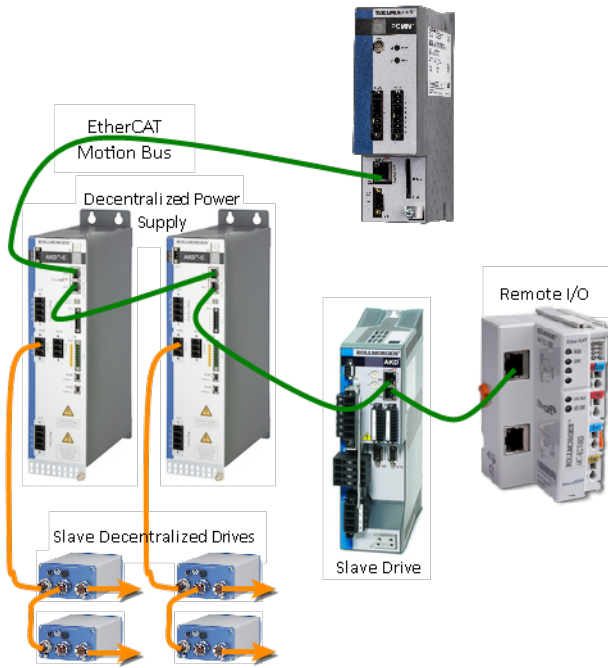

Figure 5-37: EtherCAT Network - Physical View

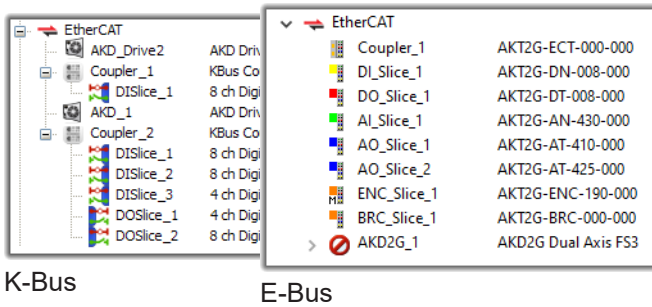

Figure 5-38: EtherCAT Network - Logical View

During the scan operation, all physical devices connected to the EtherCAT network are discovered and identified.

- The KAS-IDE lists the devices in the order they are connected.
- Kollmorgen devices, which include AKD and S300/S700 drives, Standard I/O Couplers, and remote I/O terminals, include detailed information for each device.
 - See "Remote Input/Output Terminals" (→ p. 697) for a list.

The status of devices can be determined by their icon in the logical view.

EtherCAT device icon descriptions

Icon	Meaning	Description
(device icon)	Normal	The device has been added by scanning the system. The associated ESI file has been found. The icon varies by device, but is the icon set by the manufacturer in the ESI file.
	Excluded	The device has been added manually or has been disassociated from a discovered device.
	ESI missing	The ESI file is missing.

Icon	Meaning	Description
	Error	For AKD, shown when there is an error.

5.11.1.1.1 Scan Limitations

- I/O slices for Standard I/O Coupler do not reveal their Device IDs.
- The discovery feature does not differentiate between AKT-DN-004-000 and AKT-DNH-004-000 I/O terminals.
 - Nor between AKT-DN-008-000 and AKT-DNH-008-000.
- Devices other than those made by Kollmorgen are identified by the Vendor Name (or ID number) and Product Name (or ID number).
 - If the device is missing an ESI file, the ESI file supplied by the device Vendor must be imported.
 - The ESI file is required by the IDE to decode and display the Product Name, Device Description, and other details.
- ESI files for any MDP devices connected to the network should be added to KAS-IDE's ESI library before starting a scan.
 - If the ESI file for an MDP device is not available, then the scan cannot identify the device and cannot discover any physical or logical modules under the device.

5.11.2 EtherCAT Master Settings tab

This tab includes configurations for the EtherCAT bus master.

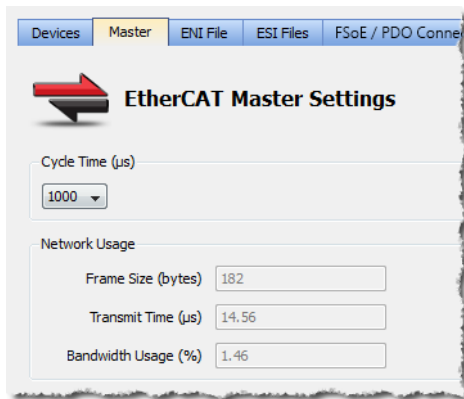

Figure 5-39: EtherCAT Master Settings

Item	Description
Cycle Time (µs)	<p>Duration of one cycle in microseconds to define the time base period for scheduling the motion and the PLC programs.</p> <p>Available times include:</p> <ul style="list-style-type: none"> • 250 • 500 • 1000 • 2000 • 4000 <p>• See "Tasking Model / Scheduling" (→ p. 819) for more information about scheduling.</p>

Item	Description
Frame Size	<p>The total size (in bytes) of the EtherCAT frame sent cyclically.</p> <ul style="list-style-type: none"> The size is proportional to the number of EtherCAT slaves (and consequently the PcDO data) on the network. The EtherCAT frame size is between 84 to 1500 bytes.
Transmit Time	The time (in microseconds) that it takes to send a frame.
Bandwidth Usage	<p>An estimation of the percentage of the cycle time used to transmit a frame of data.</p> <p>Bandwidth value goes up when cycle time decreases (see calculation below)</p>
Working Counter Error Limit	<p>A configurable threshold for generating an E30 error and shutdown of EtherCAT communication.</p> <ul style="list-style-type: none"> The default setting is 3 Errors in 1000 frames. Other options are: <ul style="list-style-type: none"> Trigger on 1st Error 2 Errors in 1000 frames 10 Errors in 1000 frames 100 Errors in 1000 frames Disabled <ul style="list-style-type: none"> If the Disabled option is selected, the Master keeps the EtherCAT network running in op mode. It is up to the application to decide if it is appropriate to shut down the Master's EtherCAT communication (MLMotionStop). <ul style="list-style-type: none"> The slave device state for EtherCAT communication errors is determined by the manufacturer. AKD drives transition to Init state when 7 consecutive packet failures are encountered and the drive executes a controlled stop. <p>See "EtherCAT Error Messages" (→ p. 846) for more information about working counter.</p>

The read-only fields show **(unknown)** when the **Use imported file** check box is selected.

Otherwise, they are recalculated and refreshed each time:

- A device is added or removed.
- A device simulation state changes.
 - See "EtherCAT Devices tab" (→ p. 322) for more information.
- The **Use imported file** check box is cleared.

See "ENI File tab" (→ p. 329) for more information.

5.11.2.0.1 Bandwidth Calculation Algorithm

The Bandwidth (BW) usage calculation takes into account the calculated frame size and the Ethernet speed (100 Megabits per second).

$$BW\% = \text{Transmission time} / \text{Cycle Time}$$

With Transmission time (μsec) = (Frame Size in bytes * 8) bits / 100 * 10⁶ bps

Example

If Frame Size = 100 bytes
then Transmission Time = 100*8 / (100*10⁶) = 8 μsec

If cycle time = 1000 μ sec
 then BW% = 8/1000 = 0.8 %

5.11.3 ENI File tab

During the [compilation](#), the KAS-IDE generates the EtherCAT Network Information (ENI) file based on the EtherCAT devices defined in the project.

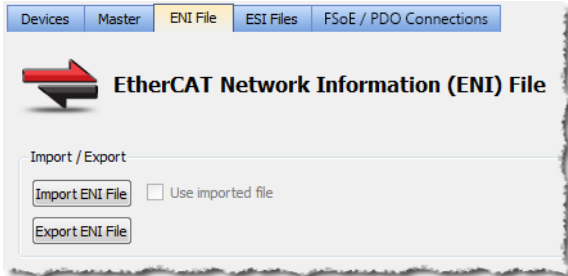

Figure 5-40: ENI File tab

5.11.3.1 Import or Export an EtherCAT ENI File

Item	Description
Import ENI File	Used to browse and select an ENI file to be imported. <ul style="list-style-type: none"> If the file is successfully imported into the project, the Use imported file option is automatically selected. <ul style="list-style-type: none"> Once imported, the ENI file is added to the project. This enables you to include EtherCAT devices in the project that are not natively supported by KAS. See "Add an Unsupported EtherCAT Device" (→ p. 581) for more information.
Use imported ENI file	Used to specify whether or not to use the imported ENI file.
Export ENI File	Used to export the ENI file generated by the KAS-IDE. <ul style="list-style-type: none"> Specify the name and directory for the file. Only the logical devices in the project tree that are mapped to a physical device (and not simulated) are taken into account when generating the ENI file. This export can be useful if you want to use the file in another context or with another program.

ⓘ IMPORTANT

Importing an external ENI file overrides all EtherCAT project device information and configuration settings in the KAS-IDE.

These views and configurations are **not** applicable when using an imported ENI file:

- Project View: All devices located under the EtherCAT node.
- EtherCAT Device View tabs:
 - General Properties
 - PDO Selection/Mapping
 - Distributed Clock
 - CoE Init-Commands
- Slice I/O Properties
- Mapping PLC Variables to Slice I/O or PDO objects.

Information displayed in the views may not match the imported ENI file.

5.11.3.2 Use an Imported ENI File

- The KAS-IDE works in a degraded mode when using an imported ENI file, and the [Mapped to Axis](#) settings are disabled.
 - This is because the information about the devices in the project tree and the EtherCAT widget table is no longer relevant.
- When using an imported configuration file these parameters must be manually set for each axis:
 - the type of motion bus.
 - its address on the fieldbus ring.

This is done by right-clicking on the Axis Pipe Block and selecting the **Properties** command.

- Scan Devices must be run from the "EtherCAT Devices tab" (→ p. 322) before downloading the application to the controller.

5.11.4 ESI Files tab

This tab lists the available EtherCAT Slave Information (ESI) files and provides the ability to add and remove files.

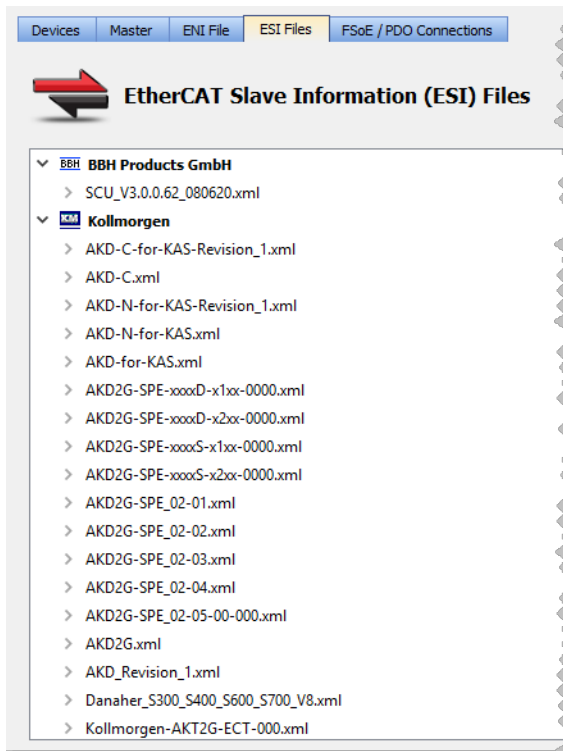

Figure 5-41: The ESI Files tab

ESI files are sorted by vendor and then by the files provided by the vendor.

Each file lists the device it supports including:

- Device name
- Device description
- Device revision number

ESI files are easily added to the list by clicking the **Add** button and navigating to where the file is saved. The **Delete** button removes a file from the list but not your hard drive.

TIP

KAS-IDE manages Kollmorgen devices (AKD2G, AKD, AKD-N, etc.) and automatically installs and/or upgrade their ESI files to the latest version.

The KAS-IDE allows Kollmorgen ESI files to be upgraded, but downgrading is not possible.

Example: The Kollmorgen ESI files **AKD-for-KAS.xml** or **AKD-N-for-KAS.xml** should not be manually imported.

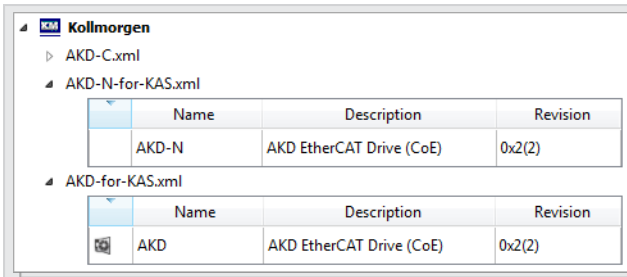

Figure 5-42: Do not overwrite these files.

Under special circumstances, Kollmorgen ESI files may be manually upgraded. We recommend working with a Kollmorgen representative when doing so.

See "ESI File Management" (→ p. 334) for more information on working with ESI files,

⚠ WARNING

WARNING: Replacing an ESI file changes the configuration of any associated device to the new file. You are prompted to confirm or cancel replacing an ESI file and the associated device configurations.

ESI files are replaced when:

- Opening a project file that contains an ESI file that is different from the file in the KAS Internal Library of ESI files stored on the PC.
 - You are prompted to select either:
 - **term_A** (use the version in the project).
Selecting **term_A** overwrites the ESI Internal Library version.
 - **term_B** (use the ESI Internal Library version).
- Click the **Add** button in the ESI Files tab view and import an ESI file that either:
 - Already exists in the KAS Internal Library of ESI Files stored on the PC.
 - Contains duplicate device information that already exists in the KAS Internal Library of ESI Files stored on the PC.

🚫 IMPORTANT

It is strongly recommended that you do not add or remove ESI files while multiple instances of the KAS-IDE are open.

Doing so modifies a global cache of ESI files.

Changes to the global ESI file cache from one instance of the KAS-IDE could create unexpected consequences in another instance.

5.11.5 FSoE / PDO Connections tab

The Fail Safe over EtherCAT (FSoE) tab displays devices discovered on the EtherCAT network, listing their Input (Tx) and Output (Rx) PDOs.

This provides you with a way to connect an Input PDO to an Output PDO.

The KAS Runtime copies the PDO data between the connected PDOs when EtherCAT is in operational mode. This feature makes it possible to transfer safety-critical process data via the EtherCAT frames. The FSoE protocol, communication, and state machine are handled by the EtherCAT Safety devices.

👉 TIP

Connected PDOs are intended for FSoE operation.

This feature is not limited to FSoE, it could be useful for any application that need to copy PDO data between EtherCAT devices.

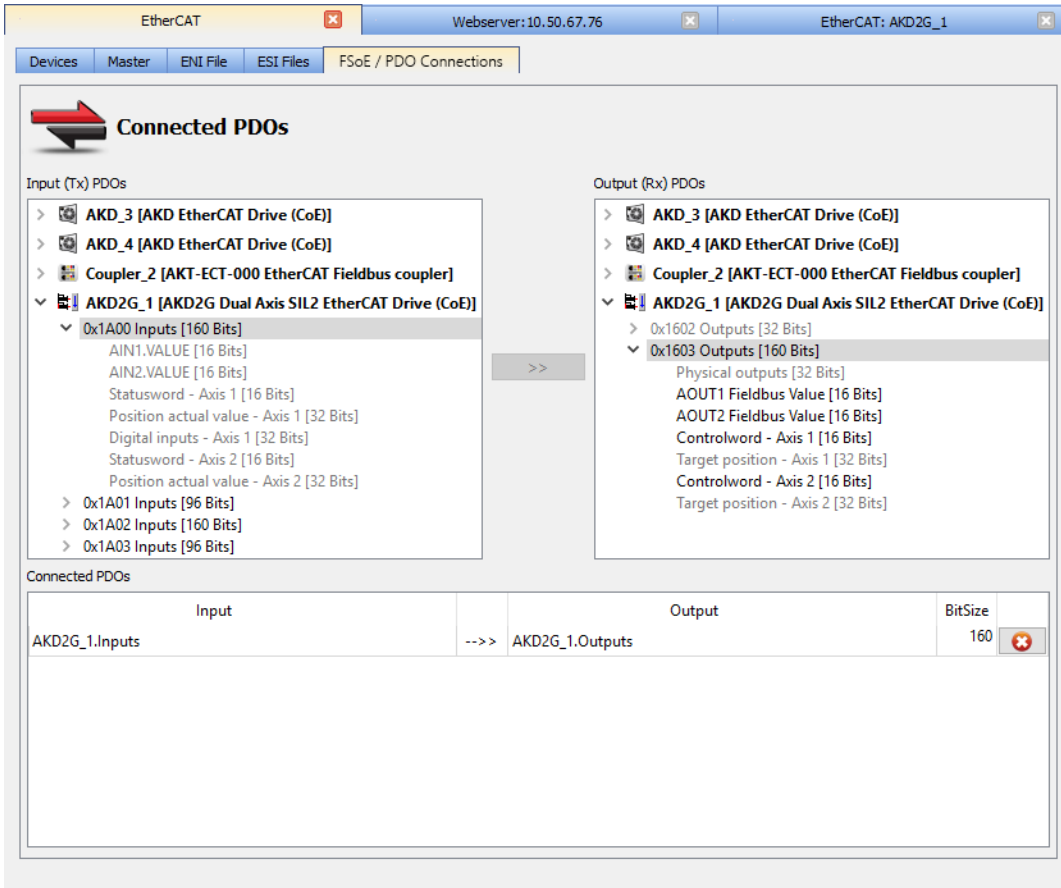

How to Map FSoE PDOs

These instructions assume you have already scanned the EtherCAT network.

1. Double-click (or right-click) on EtherCAT in the Project Explorer, and select the FSoE tab.
2. Select the desired Input PDO.

Output PDOs which may be mapped (or paired) to the input are shown in black. Outputs of a different size are grayed out.

3. Select the desired Output PDO.
4. Click on the Connect PDOs button.

Connected PDOs are listed at the bottom of the tab.

TIP

See "Set Up FSoE Master and an AKD2G with SafeMotion Monitor" (→ p. 582) for an example of mapping PDOs.

How to Unmap FSoE PDOs

1. Double-click (or right-click) on EtherCAT in the Project Explorer, and select the FSoE tab.
2. Select the desired pair of Connected PDOs from the list at the bottom of the tab.
3. Click the Delete Connection button.

What happens to the connected PDO(s) when a device is removed using the ECATDeviceAction function block?

The PDO's connection is removed internally when the device is removed using the ECATDeviceAction function block and has its PDO connected to another device.

The PDOs are automatically reconnected when the device is connected back to the EtherCAT network.

NOTE

Inputs and Outputs must have identical Bit sizes in order to be paired.

See Also

"Safety over EtherCAT" (→ p. 792)

5.11.6 ESI Files with References (MDP)

ESI files may contain references to other ESI files or to EDS files. The referenced files may be located in the same directory or sub-directories. ESI files with references are common with MDP (Modular Device Profile) devices. This is because the ESI files for the modules are shared between several device Products and/or Revision Numbers.

When adding an ESI file with references to the IDE's ESI library, *only* add the top-level file that contains the references to the other files and sub-directories. The IDE will check the selected ESI file for reference files and automatically add the reference files.

For example, when adding the Murrelektronik Cube67 MDP (modular) device ESI file, select the top-level ESI file.

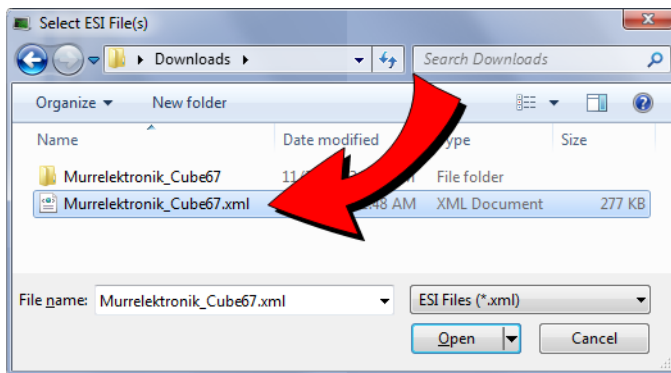

Do not select the lower-level module ESI files found in a sub-folder.

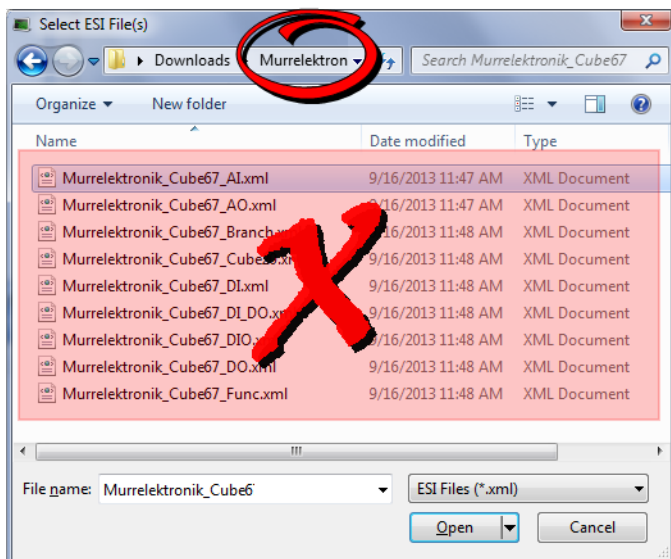
**ⓘ IMPORTANT**

WARNING: Always add the top-level ESI file to the IDE's ESI library. Do not add, delete, or upgrade lower-level module files to the IDE's ESI library. Removing or replacing lower-level files may cause unexpected or unknown behavior. If any reference files are missing when the top-level file is added to the IDE's ESI library, an error message will notify you which sub-files are missing.

5.11.6.1 EtherCAT Device Configuration - MDP Devices

The KAS-IDE incorporates the ability to configure and manage EtherCAT MDP (modular device profile) devices. Devices which meet the ETG.5001 standard may be added to the EtherCAT network in the Project Explorer and modules may be mapped to them. This includes devices such as I/O device modules, safety device modules, or fieldbus gateway modules.

5.11.7 ESI File Management

ESI files which are referenced from a project's EtherCAT devices are stored in the project.

- Upon opening a project the ESI files are copied to the local folder.

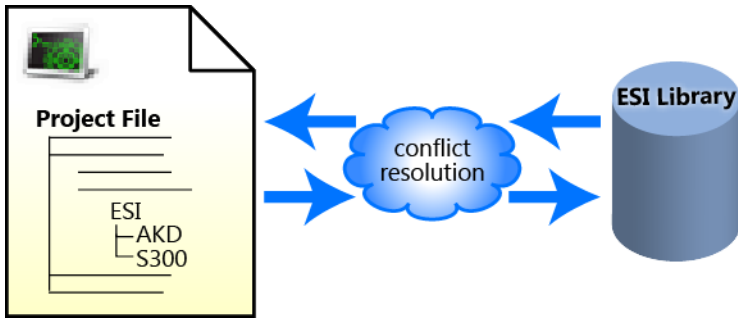

Figure 5-43: Opening — Upon opening a KAS project, the project's ESI files are compared to the internal library. If there are conflicts, you are prompted to resolve them.

- Adding or deleting ESI files from KAS-IDE affects the internal library

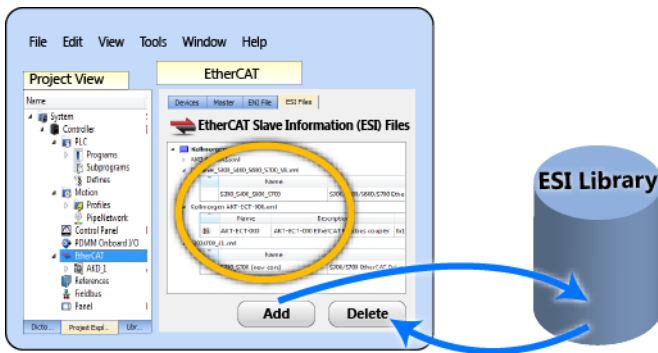

Figure 5-44: Adding/Deleting — Adding or deleting an ESI file from the KAS-IDE affects KAS's internal library of ESI files.

- Upon saving a project the ESI files are copied to (project folder)\Controller\ESI.

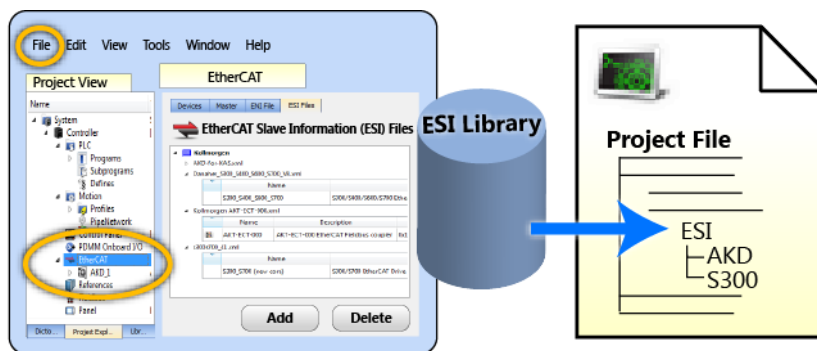

Figure 5-45: Saving — When a KAS project is saved, a copy of the ESI file(s) is included in the project file.

TIP

The ESI files are stored along with the project so the project can easily be moved to another location and it will still compile. It still compiles because the ESI files are copied back to the local folder.

NOTE

There is the possibility that the names and/or contents of files can be conflicting. The system checks the files before adding them. You will be prompted to chose the correct file should any conflicts be found.

⚠ WARNING

WARNING: Replacing an ESI file changes the configuration of any associated device to the new file. You are prompted to confirm or cancel replacing an ESI file and the associated device configurations.

ESI files are replaced when:

- Opening a project file that contains an ESI file that is different from the file in the KAS Internal Library of ESI files stored on the PC.
 - You are prompted to select either:
 - **term_A** (use the version in the project).
Selecting **term_A** overwrites the ESI Internal Library version.
 - **term_B** (use the ESI Internal Library version).
- Click the **Add** button in the ESI Files tab view and import an ESI file that either:
 - Already exists in the KAS Internal Library of ESI Files stored on the PC.
 - Contains duplicate device information that already exists in the KAS Internal Library of ESI Files stored on the PC.

ⓘ IMPORTANT

It is strongly recommended that you do not add or remove ESI files while multiple instances of the KAS-IDE are open.

Doing so modifies a global cache of ESI files.

Changes to the global ESI file cache from one instance of the KAS-IDE could create unexpected consequences in another instance.

5.12 EtherCAT Devices

This section provides reference for defining EtherCAT devices.

- Devices are added by right-clicking the **EtherCAT** entry in the Project Explorer.
- Devices are seen as branches of the EtherCAT item.
- Double-clicking a device opens a tab labeled **EtherCAT: [device name]**.
- See "Configuring EtherCAT" (→ p. 322) for information on the tree entry.

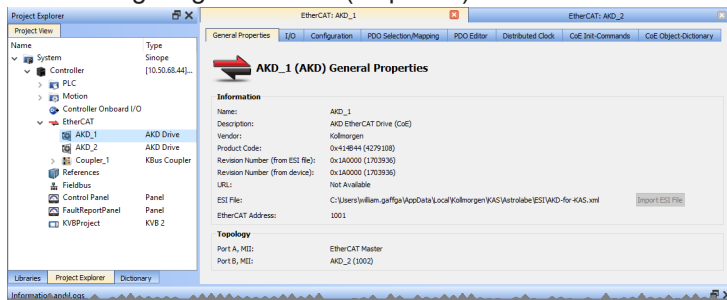

5.12.1 EtherCAT Device General Properties Tab

This tab provides information about the selected EtherCAT device and the associated ESI file. It also provides the ability to import an ESI file if one is not present. There are two ways to access this tab:

- double-click on an EtherCAT device
- right-click on an EtherCAT device and select Properties.

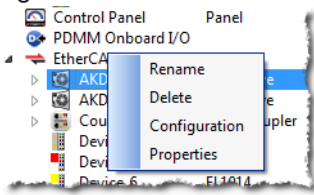

There are two main sections in the dialog: Information, and Topology.

5.12.1.1 Information

This section details the device's basic information and is not editable. In addition to the device and vendor information is the path to the ESI file associated with the device. The **Import ESI File** button is available if the ESI file is missing. This lets you select a file to associate with the device. Lastly, this section lists the **EtherCAT Address** for devices and **FSoE Address** for safety devices which have been discovered.

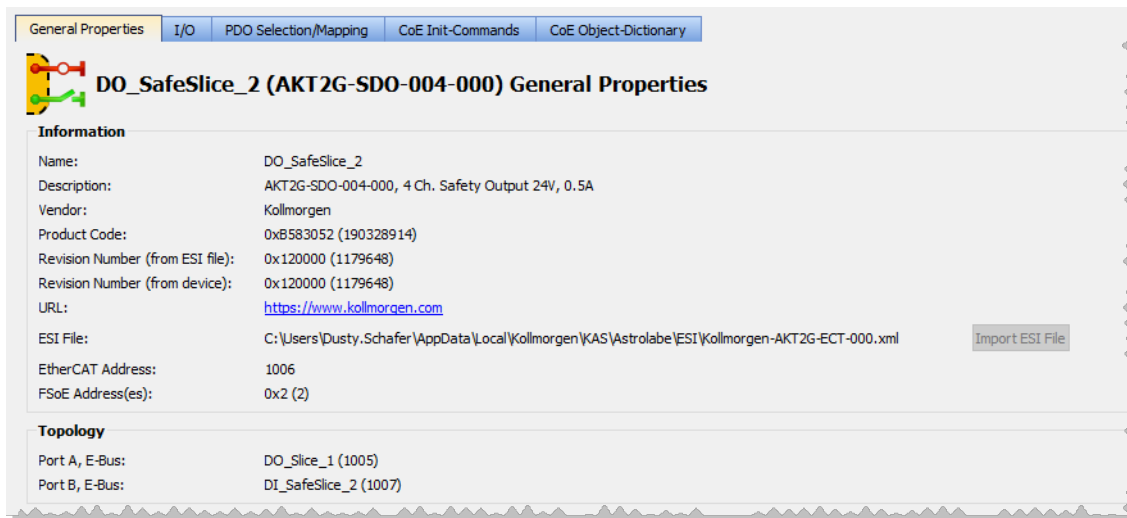

Why are the Revision Numbers different?

It is possible that there is a mismatch in the revision of firmware on the device and the revision referenced by the ESI file when the device was scanned. If this occurs, your device may not have access to the full capabilities of the latest firmware.

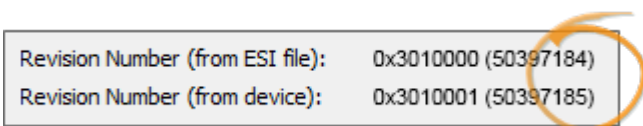

5.12.1.2 Topology

This section lists the device's ports and assignments. There are three possible states for this information.

Condition	Appearance
Physical Devices	

Condition	Appearance
Virtual Device	
ESI file is missing	

5.12.2 Map I/O from the Project Explorer

TIP

For information on mapping I/O with third-party devices, see the "PDO Selection/Mapping tab" (→ p. 340).

1. In the Project Explorer, expand the Controller node and the EtherCAT nodes to access your devices.

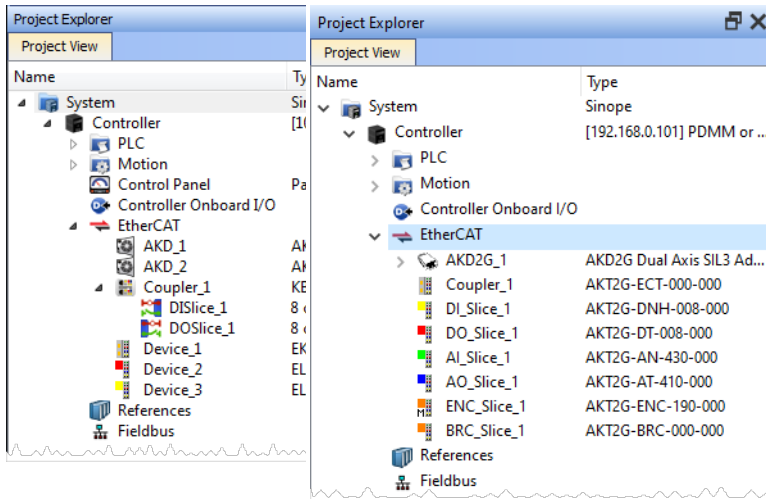

AKT (K-Bus) devices AKT2G (E-Bus) devices

2. Accessing the device properties is slightly different depending upon the device.

AKD or AKD2G

Double-click the drive and select the I/O tab.



AKD PDMM or PCMM

Double-click Controller Onboard I/O.

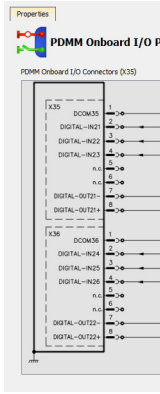

I/O Slice

Double-click the I/O Slice under EtherCAT (E-Bus) or in the Coupler entry (K-Bus).
For Slice Analog I/O and thermocouples, the offset and gain parameters must be defined.

Safety I/O Slice

Double-click the Safety I/O Slice under EtherCAT (E-Bus).
Safe Digital Inputs and Output channels are clearly identifiable by a yellow table in the I/O tab.
Digital output logic on the safety slices / devices is typically disabled by default from the standard PLC.
See the Description of Safety Parameters and the AKT2G-IO-SDO-004-000Safety Terminal with Four Digital Fail-safe Outputs table for details.

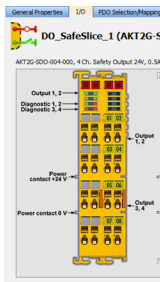

3. There are several ways to map variables:
 - Drag and drop a variable from the Dictionary onto a table entry.
 - Use the "PLC Variable Creation Wizard" (→ p. 317) for Kollmorgen devices.
 - Directly map/unmap the Inputs/Outputs to PLC variables using the "PLC Variable Selector" (→ p. 318).

Select the channel(s) to map. Selection may be done by click-dragging or shift-clicking a range of entries. The entire table may be selected by clicking on its border.

After the selection is made, right-click and select **Map** or press the **Enter** key.
This opens the "PLC Variable Selector" (→ p. 318).

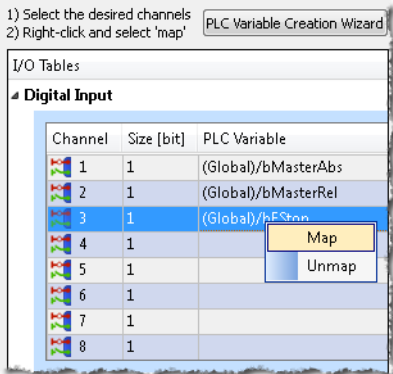

TIP

The **Unmap** command in the contextual menu is used to remove the link between the variable and the associated channel(s).
In addition, deleting a variable from the dictionary which is mapped to the channel(s) also removes the link(s).

Choose the variable to be linked to the channel(s) or PDO object.

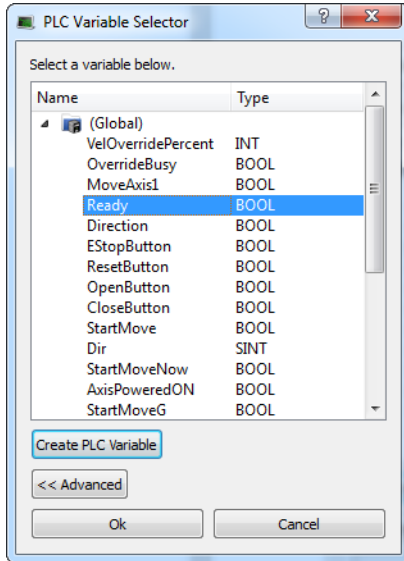

NOTE

The list of variables is filtered to display only those with relevant types.

- PLC Variable Selector displays Read Only variables when mapping the Input channels from the I/O tab.
- Variables assigned to the Safe Digital Input and Safe Digital Output channels must be Read Only.

ⓘ IMPORTANT

The limitations of PLC variable mapping are:

- Each PLC variable can be mapped to an EtherCAT I/O and exclusively to either:
 - a Controller Onboard I/O.
 - an external driver.
- Because a variable can only be mapped to one channel or PDO object, when you link a variable to a new channel or PDO object, the previous mapping is removed (even if linked to another slice or device).
- Individual bits within a variable can be mapped to multiple I/O channels on different devices (AKD, AKD PDMM, PCMM, or Slice).

Example: The same PLC variable cannot be mapped to both Profinet and a Controller Onboard I/O but it is possible with a regular EtherCAT I/O.

What happens to variables that are mapped to a device I/O which was removed using the ECATDeviceAction function block?

When a device is removed using ECATDeviceAction:

- **Variable mapped to an Analog or Digital Input Type**
 - The value of the variable becomes '0' when the mapped device is removed.
 - The device I/O value is automatically reconnected to the variable when the device is reconnected to the network.
- **Variable mapped to an Analog or Digital Output**
 - The value is not sent to the device when the mapped device is removed.
 - When the device is reconnected, the value is sent to the I/O automatically.

What happens to the PLC variables which are mapped to the X22 Connector I/Os of an AKD2G if the drive is replaced with a single-axis AKD2G which does not have an X22 Connector?

All of the I/Os mapped to the X22 connector are grayed out in the IO tab:

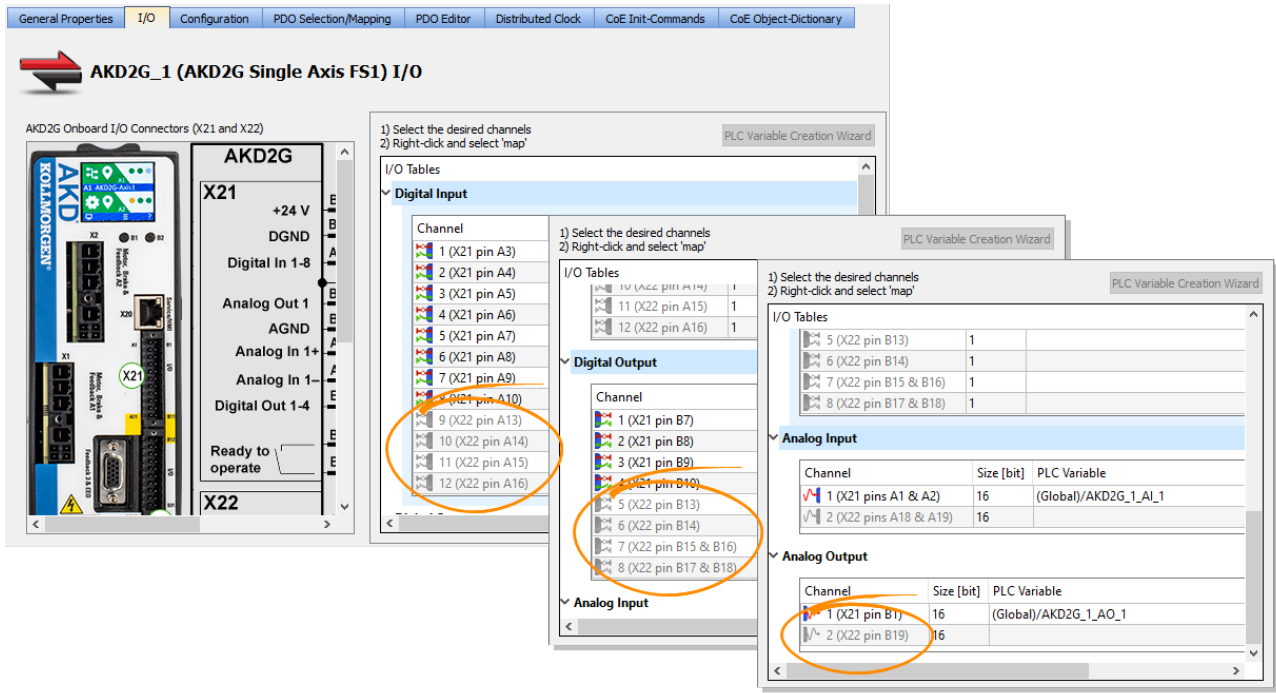

NOTE

AKD2G drives are available with various I/O options. An AKD2G drive of one variant can be replaced in the KAS project with a drive that has a different I/O option. See the **AKD2G Model Nomenclature** section in [Automation and Motion Control Programmable Automation Solutions](#) for available models and I/O options.

See Also:

- "PLC Variable Selector" (→ p. 318) for information about the **Create PLC Variable** and **Advanced** buttons.
- "Analog I/O Parameters" (→ p. 320) for information about parameters.
- "Configure Onboard I/O" (→ p. 194) for information about the AKD Onboard EtherCAT I/Os.
- "Controller Onboard I/O" (→ p. 398) for information about the AKD PDMM or PCMM local digital I/Os.

5.12.3 Configuration tab

Parameters for AKD2Gs, AKDs, and AKT2G-IO stepper modules can be set by either:

- Double-clicking the device in the project tree.
- Right-clicking and selecting **Configuration**.

This opens a Configuration tab which allows you to set the parameters for the device.

See the following for more information.

- "Configure the AKD / AKD2G Drive" (→ p. 191)
- "AKT2G-IO-SM-Lxx Stepper Drive Configuration tab" (→ p. 196)

5.12.4 PDO Selection/Mapping tab

This tab includes the PDO configurations for an EtherCAT device.

- Assigned PDOs and their objects are viewable for the Inputs (Tx) and Outputs (Rx).
- The PDOs become active when the EtherCAT network is initialized to operation mode.

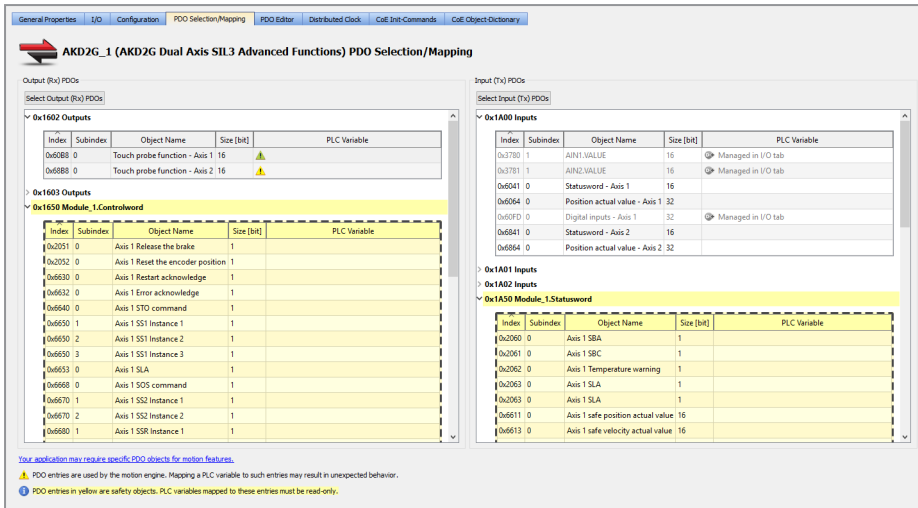

Figure 5-46: The PDO Selection/Mapping tab including FSoE objects in yellow.

TIP

- Safety PDOs are highlighted in yellow with a border.
- Any variable assigned to a FSoE PDO must be Read Only. See "About Safety, PDOs, and Variables" (→ p. 353) for more information.
- See "Set Up a Variable to Monitor Safety Data" (→ p. 344) for step-by-step instructions.

Each assigned PDO is listed by its Index (hex) and Name.

- The objects associated with each PDO are listed below the name.
- The objects are identified by their object dictionary **Index** and **Subindex**.
- The **Object Name** provides a simple description.
- The **Size** determines the data length. The **PLC Variable** mapped to the PDO objects is also listed.

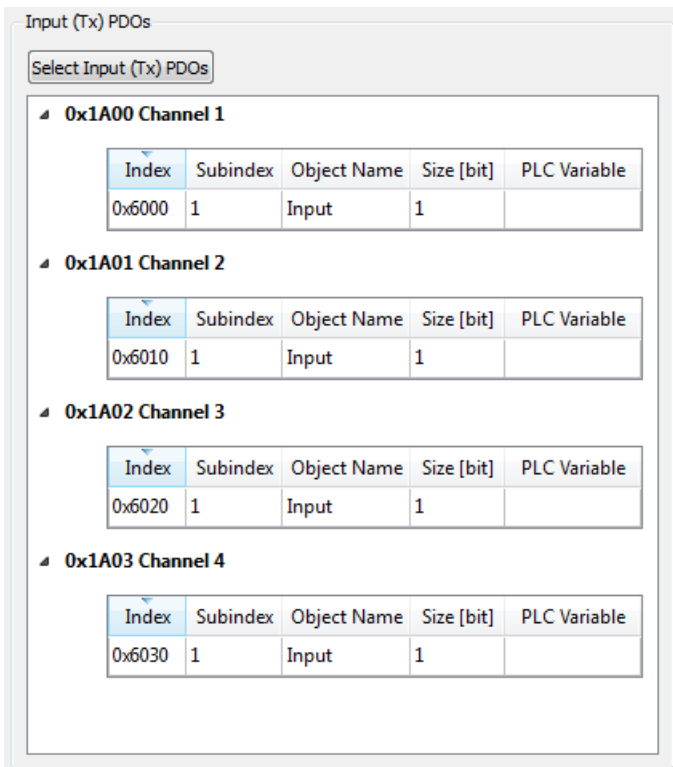

5.12.4.1 Map PLC Variable to PDO Object

PLC variables can be mapped to PDO objects by:

- Double-clicking in a PLC variable cell to open the PLC Variable Selector.
- Right-clicking in a PLC variable cell and select **Map** or **Unmap**.

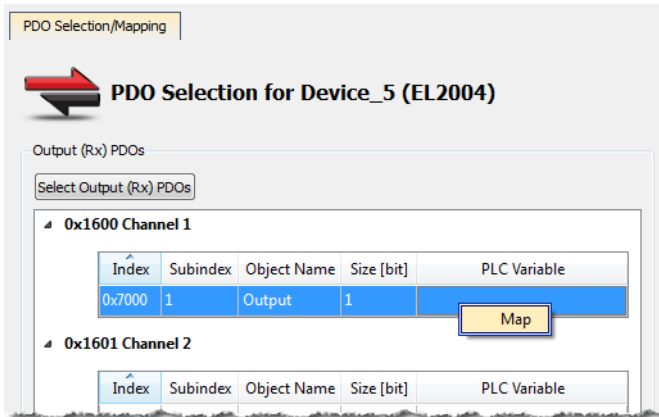

- Drag-and-drop a variable from the Dictionary to a PLC variable cell.
- Multiple objects may be selected by:
 - Shift-clicking a contiguous range of objects.
 - Ctrl-clicking non-contiguous objects.
- **Do not** map PLC variables to third-party drive PDO objects.
 - They may conflict with the KAS Runtime's internal motion engine read/write operations.

Special information regarding mapping PLC variables to safety objects

PLC variables may be mapped to safety objects in exactly the same way as any other object, but the variable must be set as Read-only.

- The PLC Variable Selector shows only Read-only variables.

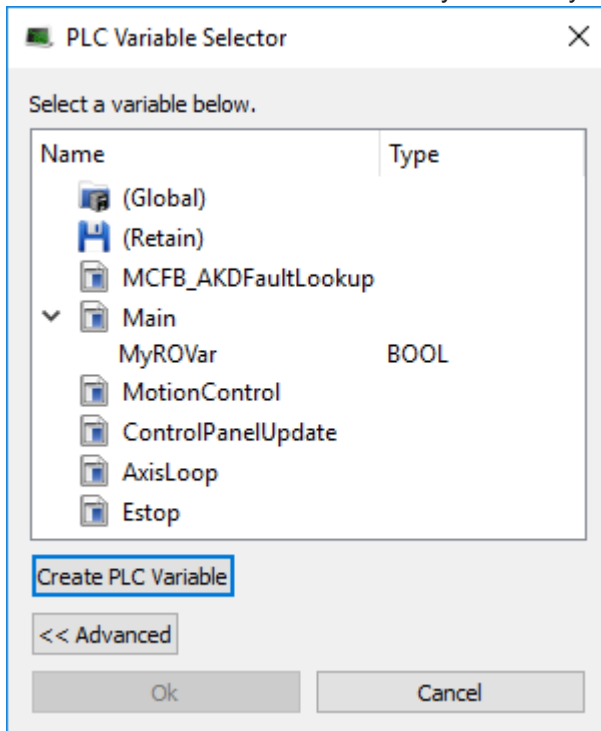

- Variables created by clicking the Create PLC Variable button, when accessed from a safety PDO, are automatically set to Read-only.
- There is no warning if an assigned variable is changed to Read / Write.
 - An error is reported when the project is compiled.

What happens to variables that are mapped to a device PDO which was removed using the ECATDeviceAction function block?

When an device is removed using ECATDeviceAction, what happens to variables depends on what they are mapped to.

- **Variable mapped to an Input (Tx) PDO object**
 - The value of the variable becomes 0 (zero) when the mapped device is removed.
 - The device PDO object is automatically reconnected to the variable when the device is reconnected to the network.
- **Variable mapped to an Output (Rx) object**
 - The link to the device PDO is removed when the mapped device is removed.
 - When the device is reconnected, the PDO object is automatically reconnected to the variable.

See "Map Input and Output to Variables" (→ p. 314) for more information.

5.12.4.2 Select Input and Output PDOs

Press the **Select Input (Tx) PDOs** or **Select Output (Rx) PDOs** button to choose the Input or Output PDOs. The appropriate dialog box opens.

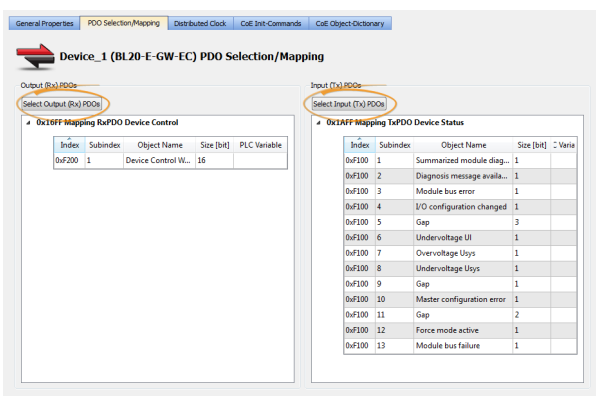

- The upper portion contains checkboxes to select specific PDOs for the EtherCAT network cyclic data.
- The lower portion contains the list of object(s) included within a specific PDO.

5.12.4.3 View the Contents of a PDO

Click a row in the upper portion of the PDO Selector dialog box to view the contents of that PDO.

- The lower portion is updated to list the associated objects.
- Example: The PDOs 0x1A02 and 0x1A03 are selected for the input objects but the contents for PDO 0x1A00 are listed because that row is selected.

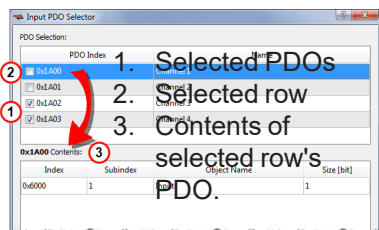

NOTE

- Some EtherCAT devices may not have selectable input and/or output PDOs.
- Some PDOs allow you to select more than one PDO at a time while others are exclusive.

- Exclusive PDOs prevent simultaneously selecting certain other PDOs.
 - Example: Choosing PDO 0x1A00 excludes selecting PDO 0x1A04:

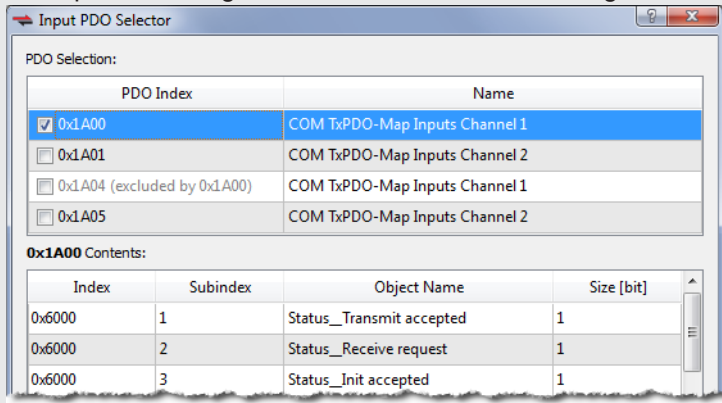

- Device vendors determine the PDO(s), content and possible selection exclusivity.
 - This information is defined inside the device vendor's ESI file.
 - Contact your local Kollmorgen representative for more information about the drive.

5.12.4.4 Set Up a Variable to Monitor Safety Data

This example creates a variable used to monitor data from a safety device. The project for this example has a BBH SCU and an AKD2G.

1. Connect the SCU and drive PDOs.
See "FSoE / PDO Connections tab" (→ p. 331).

While this step is optional, it is quite useful and will save you time and effort.

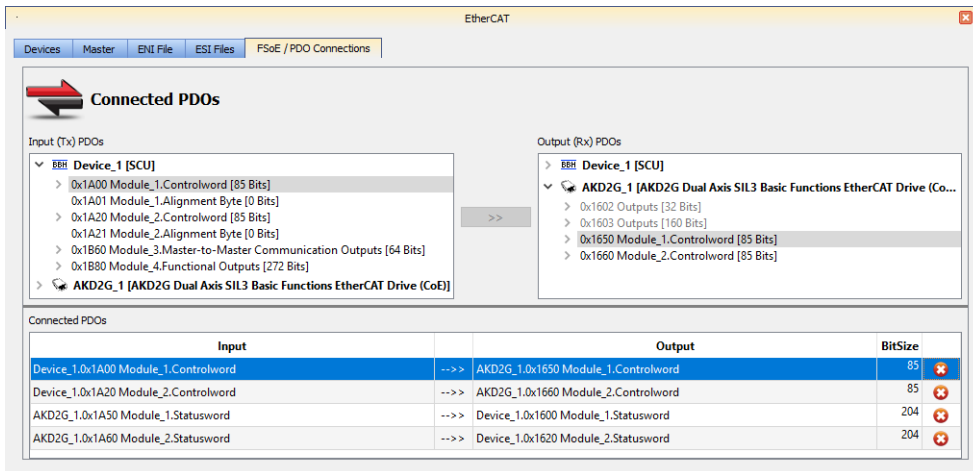

2. Right-click (or double-click) an **Input (Tx) PDOs** object that will be monitored and select **Map**.

It is recommended that you use Tx PDOs as the source for a variable as they update every cycle, where Rx PDOs may not be current.

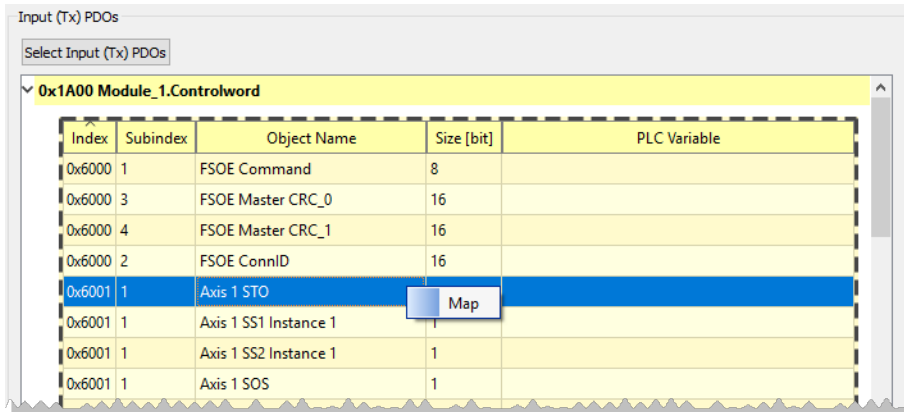

- Read-Only variables are the only ones that will be shown in the **PLC Variable Selector**. Click **Create PLC Variable**. In this case we are creating the variable inside of **Main**.

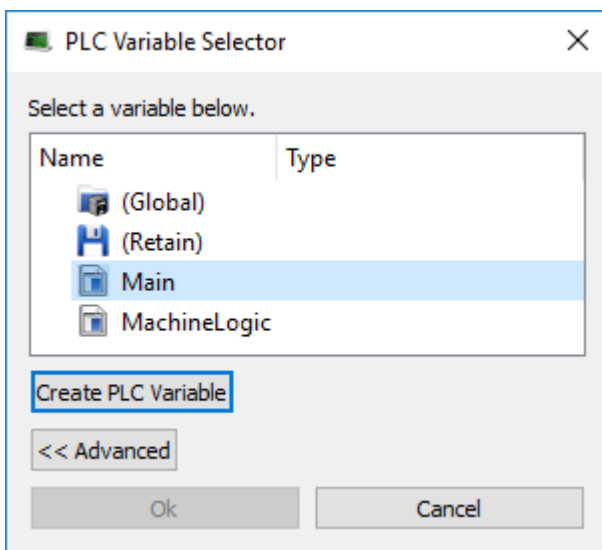

- Define a variable by giving it a name, type, and optionally an initial value and click **OK**.

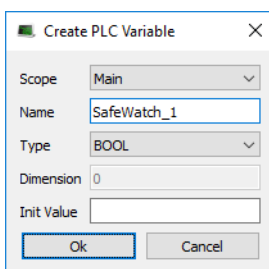

- The **PLC Variable Selector** now displays variable. Click **OK**.

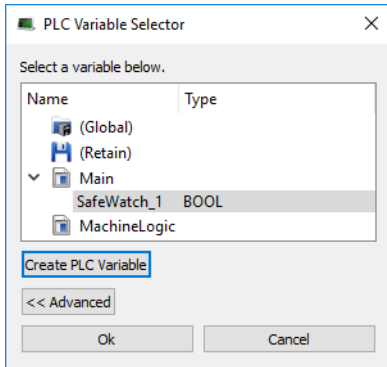

The variable is now assigned and available to monitor any object in the same Index:Subindex.

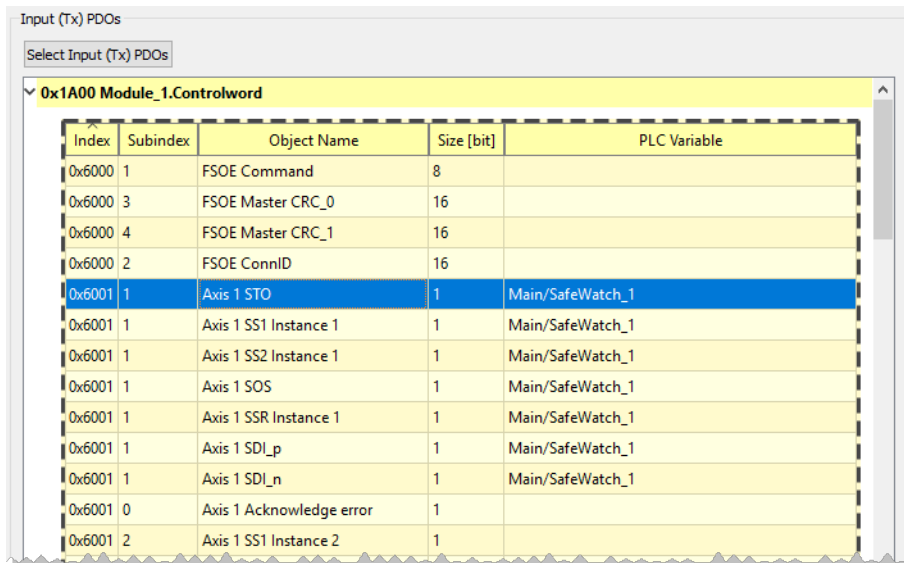

- OPTIONAL:** The variable may be further defined, such as giving it a description. Looking at it, we can see that it was created as **Read Only**. It is recommended that the variable is not changed to Read/Write. If it is changed an error will be generated when the project is compiled.

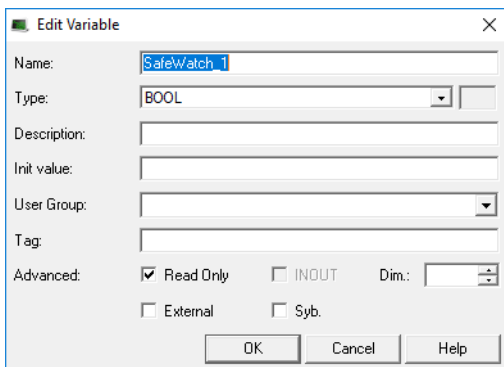

5.12.5 PDO Editor tab

This tab provides the ability to modify editable PDOs.

- There are two sections:
 - "Editable PDOs" (→ p. 347)
 - "PDO Content" (→ p. 349)

- See "PDO Restrictions and Compiler Errors" (→ p. 351) for information about compiler errors and certain constraints.

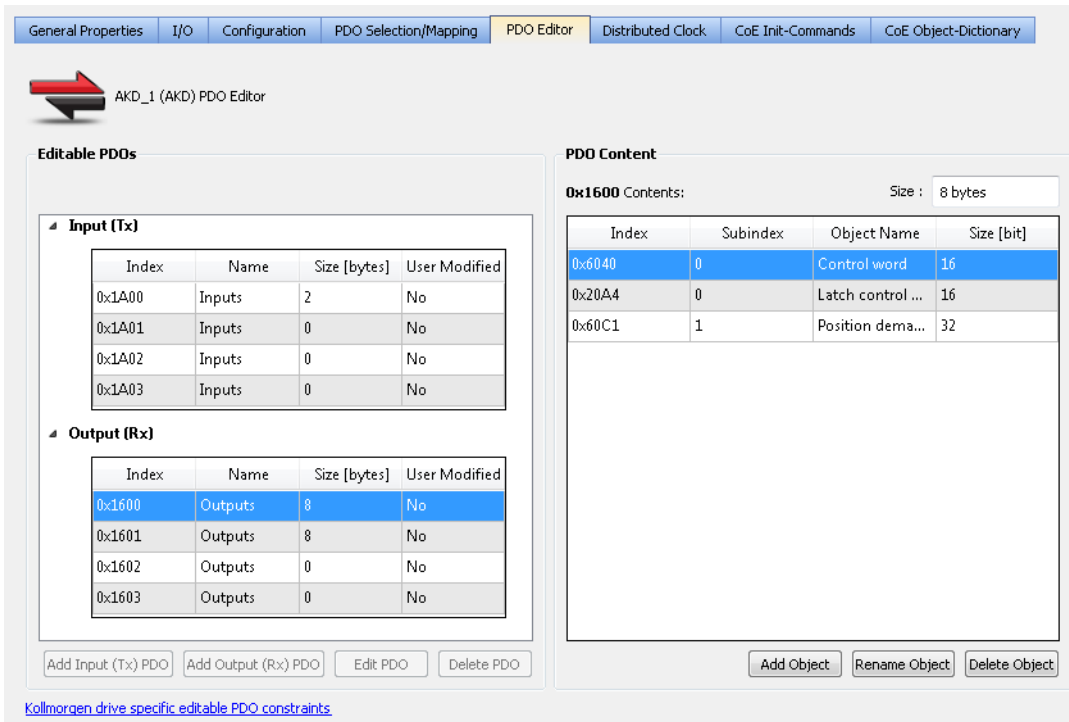
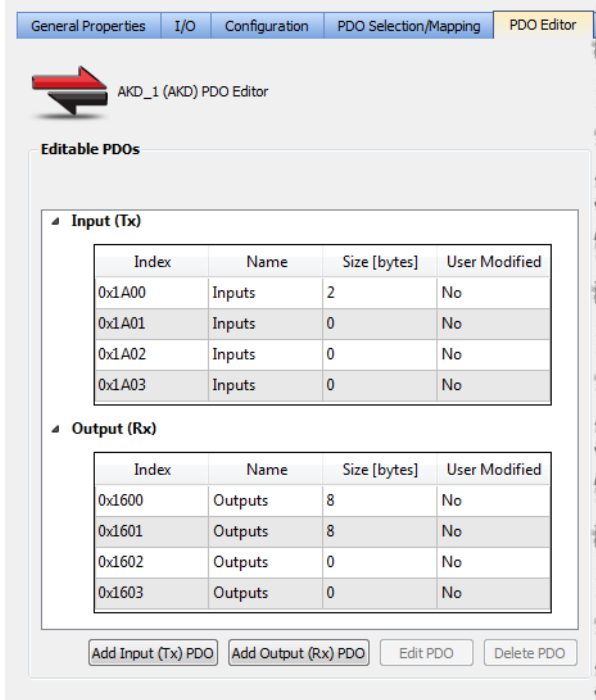

Figure 5-47: The PDO Editor tab

5.12.5.1 Editable PDOs

This section lists all of the PDOs which may be edited.

- PDOs may be created (Add PDO), modified (Edit PDO), or removed from the project (Delete PDO).
- See the EtherCAT device-specific documentation for more details.



The Input (Tx) and Output (Rx) PDOs are grouped separately. Each PDO table contains this information:

Name	Description
Index	Identification value for the PDO. The range is defined by the EtherCAT specification. <ul style="list-style-type: none"> RxPDOs: 0x1600 to 0x17FF TxPDOs: 0x1A00 to 0x1BFF
Name	Text label to identify the PDO. The name is provided either by the device vendor or user. It can be changed by the user.
Size [bytes]	Total length for the PDO object(s) data.
User Modified	Yes: Indicates the user has changed the PDO or its content. No: Indicates the PDO is the default provided by the device vendor.

The KAS-IDE compiler enforces restrictions on the sizes of individual PDOs as well as on the sum of the sizes of PDOs.

See "PDO Restrictions and Compiler Errors" (→ p. 351) for more information.

5.12.5.1.1 Add a Flexible PDO

1. Click the **Add Input (Tx) PDO** or **Add Output (Rx) PDO** button to open the **Add Input** or **Add Output** window.
2. Select an **Index** value and enter a **Name** for the PDO. The dialog performs a live check for valid entries.
3. Click **OK**.

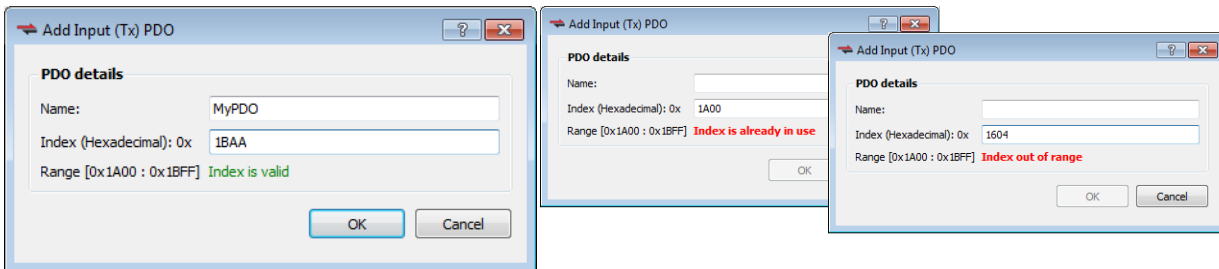

Figure 5-48: Examples of live checking for valid entries.

Objects may be added once the PDO has been created. See "Add a CoE Object" (→ p. 350).

EtherCAT device support for flexible PDOs is optional. Please consult the manufacturer’s device-specific manual for details about support for flexible PDOs and which PDO index values are supported.

5.12.5.1.2 Edit a Flexible PDO

A flexible PDO's Name and Index can be edited after it has been added.

1. Select a flexible PDO from the list of Editable PDOs.
2. Click the **Edit PDO** button.
3. Make your changes. The dialog performs a live check, enabling the OK button when an entry is valid.
4. Click **OK**.

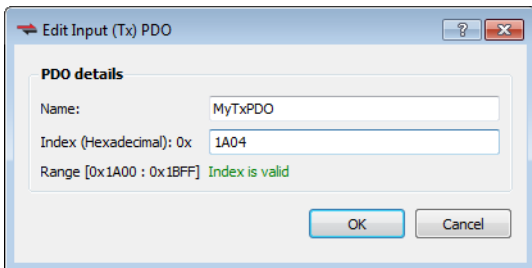

5.12.5.1.3 Delete a Flexible PDO

A flexible PDO, which has previously been added, may be deleted.

1. Select a flexible PDO from the list of Editable PDOs.
2. Click the **Delete PDO** button.
3. Confirm your deletion by clicking **OK**.

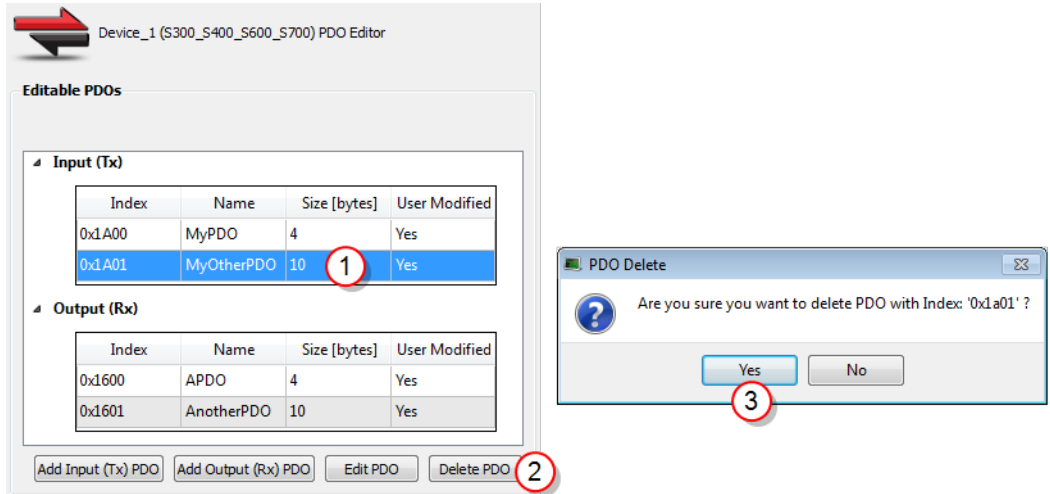

5.12.5.2 PDO Content

This section lists the objects within the currently selected PDO.

- Objects may be created (**Add Object**), modified (**Edit Object**), or removed from the project (**Delete Object**).
- Select a PDO in the **Editable PDOs** section (left side of dialog box) to view the objects in a PDO.
- The list of objects appear in the **PDO Content** section (right side of dialog box).

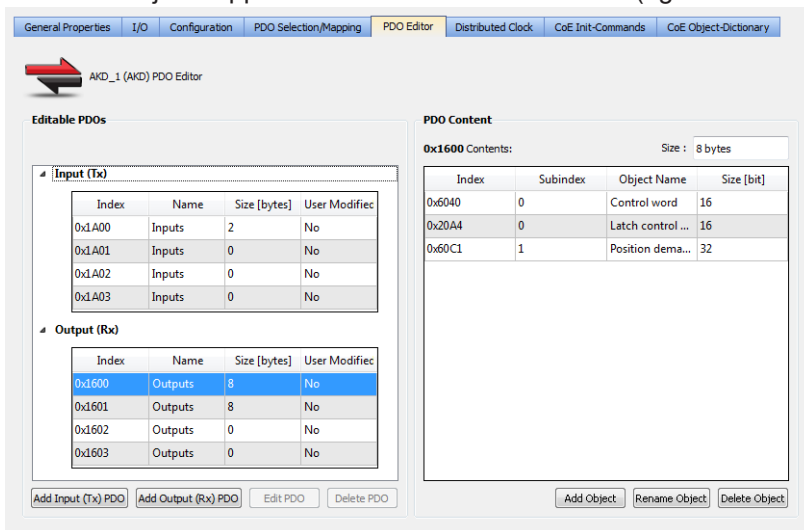

Name	Description
Index	Identification value for the PDO. The range is defined by the EtherCAT specification. <ul style="list-style-type: none"> • RxPDOs: 0x1600 to 0x17FF • TxPDOs: 0x1A00 to 0x1BFF

Name	Description
Name	Text label to identify the PDO. The name is provided either by the device vendor or user. It can be changed by the user.
Size [bytes]	Total length for the PDO object(s) data.
User Modified	Yes: Indicates the user has changed the PDO or its content. No: Indicates the PDO is the default provided by the device vendor.

NOTE

Constraints for the Kollmorgen AKD device family:
The PDO content **Size** field is highlighted in red if the Editable PDO content size is greater than 8 bytes.

5.12.5.2.1 Add a CoE Object

1. Select a PDO in the **Editable PDOs** section.
2. Click the **Add Object** button to show the **Add CoE Object to PDO** window.
3. Select an object from the **CoE Object Dictionary** or manually enter the Name, Index, Subindex and Size data, and click **Ok**.

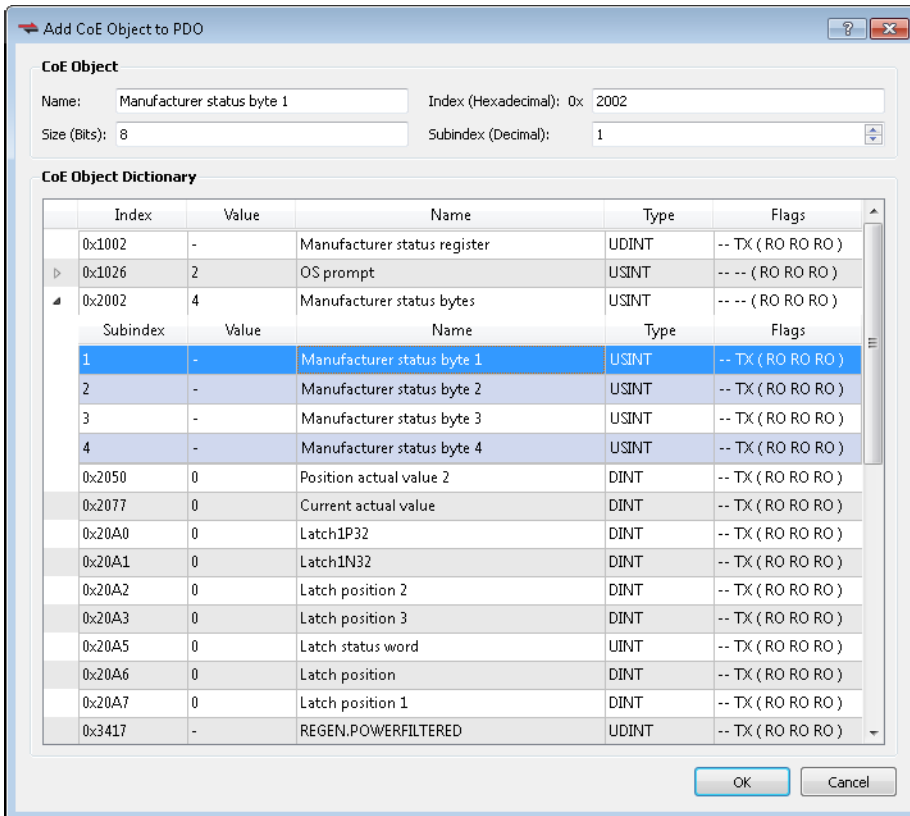

NOTE

The Flags indicate whether an object can be selected for an Input (Tx) or an Output (Rx) PDO. If the Flags are “- - -” then the object is not eligible for the PDOs. Selecting the wrong object type will generate an error.

5.12.5.2.2 Rename a CoE Object

1. Select a PDO from the **Editable PDOs** list.
2. Select the object to be renamed from the PDO Content.
3. Click the **Rename Object** button.

4. In the **Rename** pop up, enter the new name.
5. Click **Ok**.

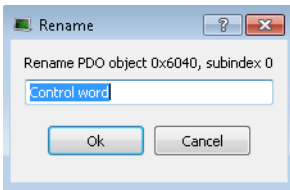

5.12.5.2.3 Delete a CoE Object

1. Select a PDO from the **Editable PDOs** list.
2. Select the object to be deleted from the PDO Content.
3. Click the **Delete Object** button.
4. Confirm the deletion.

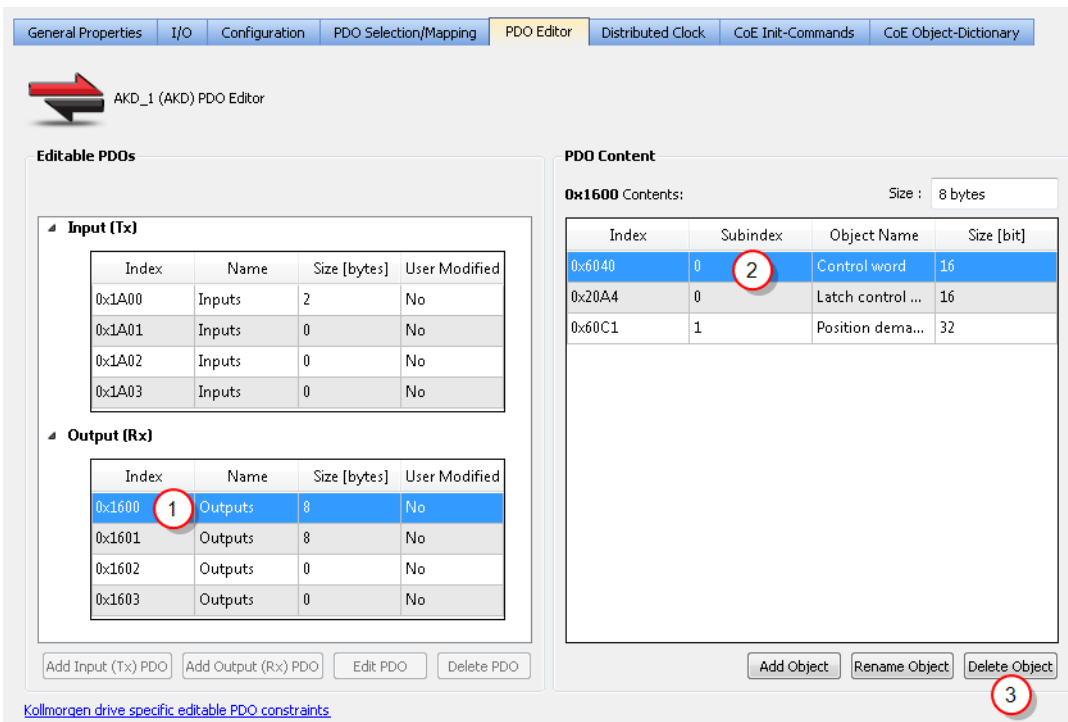

5.12.5.3 PDO Restrictions and Compiler Errors

5.12.5.3.1 Restrictions for AKD Devices

The KAS-IDE compiler enforces the following restrictions to the editable PDOs for AKD devices:

- The maximum byte count for the content of an individual PDO (both selected and unselected) is 8 bytes. The PDO content **Size** field will be highlighted in red if the Editable PDO content size is greater than 8 bytes.
- The total maximum byte count for the content of all Tx PDOs (both selected and unselected) is 32 bytes.
- The total maximum byte count for the content of all Rx PDOs (both selected and unselected) depends upon the firmware.

Firmware Version	Byte Limit	Notes
v1-17 or later	32 bytes	This is the byte limit when the EtherCAT parameter ECAT.LEGACYREV is set to 0.

Firmware Version	Byte Limit	Notes
v1-16 or later	20 bytes	This is the byte limit when the EtherCAT parameter ECAT.LEGACYREV is set to 1.
v1-15 or earlier	20 bytes	

- The total byte count for the content of all selected Tx PDOs must be **even**. This does not apply to AKD2G devices.
- The total byte count for the content of all selected Rx PDOs must be **even**. This does not apply to AKD2G devices.

TIP

The object 0x00 can be used to pad the PDO to get the total byte count to an even value.

Compiler errors will be generated if these restrictions are not met. Example compiler errors:

In AKD_1, the size of Rx PDO 0x1600 is greater than the limit: 9 > 8

In AKD_1, the total byte count for all editable Rx PDOs is greater than the limit: 39 > 32

In AKD_1, the total byte count for all editable Rx PDOs that are assigned is not even: 29

5.12.5.3.2 Restrictions for AKD2G Devices

The KAS-IDE compiler enforces the following restrictions to the editable PDOs for AKD2G devices:

- PDOs have a size constraint of 128 bytes per PDO.
- The total maximum byte count for the content of all Rx PDOs (both selected and unselected) is 512 bytes [(128 per PDO) x 4 = 512 bytes].
- The total maximum byte count for the content of all Tx PDOs (both selected and unselected) is 512 bytes [(128 per PDO) x 4 = 512 bytes].
- There is a limitation to the number of PDO objects, based on the the Sample Rate / Cycle Time.

Sample Rate	Cycle Time	Max. PDOs
4kHz	250µs	14 Rx, 14 Tx
2kHz	>500µs	30 Rx, 30 Tx

5.12.5.3.3 Restrictions for All Other Devices

The KAS-IDE compiler enforces the following restriction to the editable PDOs for all devices:

- The maximum byte count for the content of an individual PDO (both selected and unselected) is 64 bytes.

Compiler errors will be generated if these restrictions are not met. Example compiler errors:

In Device_1, the size of Tx PDO 0x1A16 is greater than the limit: 66 > 64

5.12.5.4 Redundant PDO Entries

It is possible in the KAS-IDE to have the same PDO entry occur in multiple PDOs (or even in a single PDO).

- A PDO entry is uniquely defined by an index and a subindex.
- The name of the entry is irrelevant in regards to identification.

In this example:

- The entry defined by index 0x6040, subindex 0, appears in the Rx PDOs 0x1600 and 0x1604.
- The entry 0x3470 and subindex 4 appear in two different PDOs.

5.12.5.4.1 Redundant Rx PDO

The redundant Rx PDO would generate this compiler error:

```
EtherCAT: ERROR: In AKD_1, PDO object index 0x6040, subIndex 0 is
redundant. It is in the following PDO(s): 0x1600, 0x1604
```

Attempting to export the ENI file fails with this error:

```
Failed to export ENI file, check the logs for more details.
```

5.12.5.4.2 Redundant Tx PDO

A redundant Tx PDO entry does not prevent a successful compilation nor generate an error when exporting the ENI file.

A redundant Tx PDO entry generates a compiler warning:

```
EtherCAT: Warning : In AKD_1, PDO object index 0x3470, subIndex 4 is
redundant. It is in the following PDO(s): 0x1A04, 0x1B23
```

5.12.5.5 About Safety, PDOs, and Variables

This topic discusses PDOs, safety objects, and variable mapping. Within the PDO Selection / Mapping tab any safety-related objects are clearly identifiable by being in a yellow table. Mapping a variable to an object is easily done by any of the following methods.

- Double-clicking on the object and then selecting or creating a variable
- Right-clicking on the object and selecting Map and then selecting or creating a variable
- Dragging an existing variable from the Dictionary to the object

Variables assigned to a safety object must be Read Only. Variables that are Read/Write will not show up in dialogs, nor will drag-and-drop work.

NOTE

Once a variable is assigned, there is no further validation until the project is compiled. That means a variable could be changed to Read/Write and still be assigned. When you compile the project an error will be generated.

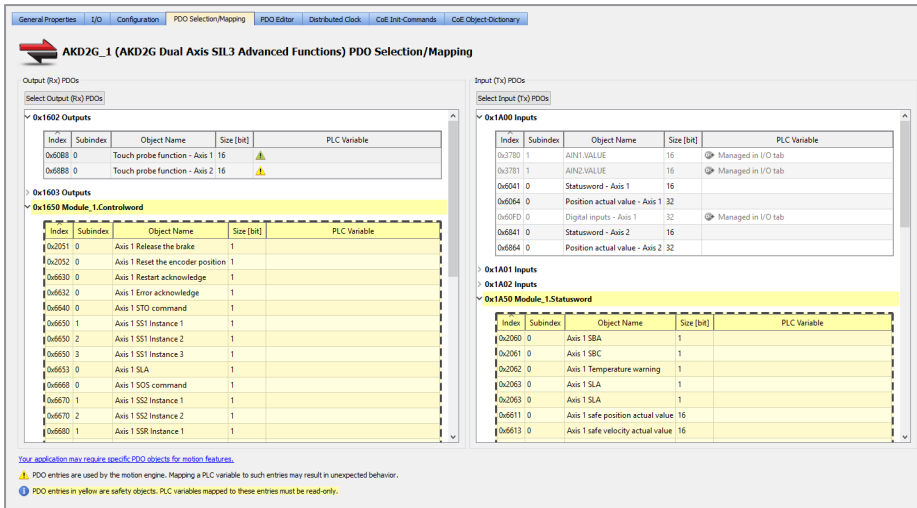

See "Set Up a Variable to Monitor Safety Data" (→ p. 344) for step-by-step instructions.

5.12.6 Distributed Clock tab

This tab is used to change settings related to the Distributed Clock for all Kollmorgen and third-party devices (both discovered and manually added).

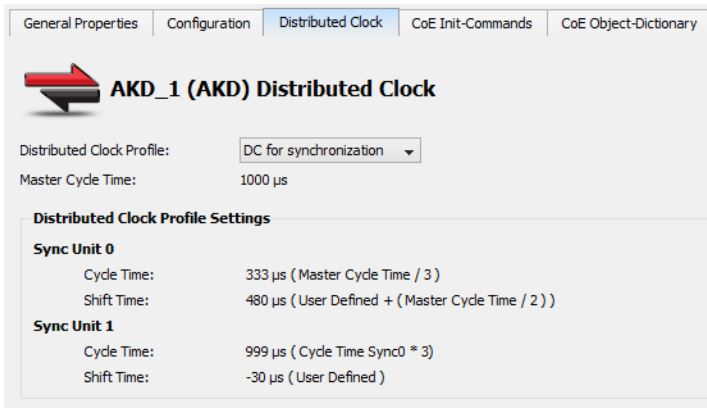

Element	Description
Distributed Clock Profile	Select the Distributed Clock (DC) operation mode. These modes cannot be edited. <ul style="list-style-type: none"> • FreeRun, DC unused, SM-Synchronous <ul style="list-style-type: none"> • Device cyclic operation is triggered by the EtherCAT master's SyncManager via the cyclic frame. • Devices are not synchronized by the reference clock. • DC-Synchron, DC for synchronization, DC-Synchronous <ul style="list-style-type: none"> • Device cyclic operation is triggered by the local distributed clock. • Devices are synchronized by the reference clock. • DC-Synchron (input based) <ul style="list-style-type: none"> • As DC-Synchron mode, with the cyclic start time so it coincides with other input slaves in the EtherCAT system.
Master Cycle Time	Base interval in microseconds and is used by the master. This is changed and automatically updated by changing the Cycle Time value on the "EtherCAT Master Settings tab" (→ p. 327) tab.

Element	Description
Sync Unit 0	<p>Cycle Time:</p> <ul style="list-style-type: none"> • Sync Unit Cycle: Unit is synchronized relative to the Master Cycle Time • User defined: Unit has its own interval <p>Shift Time:</p> <ul style="list-style-type: none"> • Unit is adjusted by the shift time
Sync Unit 1	<p>Cycle Time:</p> <ul style="list-style-type: none"> • Sync Unit Cycle: Unit is synchronized relative to the Master Cycle Time • Sync 1 Cycle: Unit is synchronized relative to the First Sync Unit • User defined: Unit has its own interval <p>Shift Time:</p> <ul style="list-style-type: none"> • Unit is adjusted by the shift time

NOTE

Some or none of the content will be available under the following scenarios:

- The Sync 0 or Sync 1 parameter is not present
- Distributed Clock is not supported by the device
- The ESI file is missing.

5.12.6.1 Oversampling devices

Some EtherCAT devices have oversampling features.

- An oversampling device is able to record (input) or provide (output) signals at a higher rate than the EtherCAT cycle time.
- This rate is called the **oversampling factor**.
- Example: Using an oversampling factor of 10 and an EtherCAT cycle time of 1ms (1Khz), an input device can record values every 100µs (1000 divided by 10).

Oversampling devices have as many PDO objects in their cyclic frames as the oversampling factor to achieve the higher rate.

- Each of these PDO objects corresponds to one sample.
- Example: An output device with an oversampling factor of 4 has four PDO objects:
 - Output 1, Output 2, Output 3 and Output 4.

The oversampling factor is tied to the Distributed Clock Profile.

A warning appears next to the DC profile selection box in the Distributed Clocks tab when a device has oversampling features:

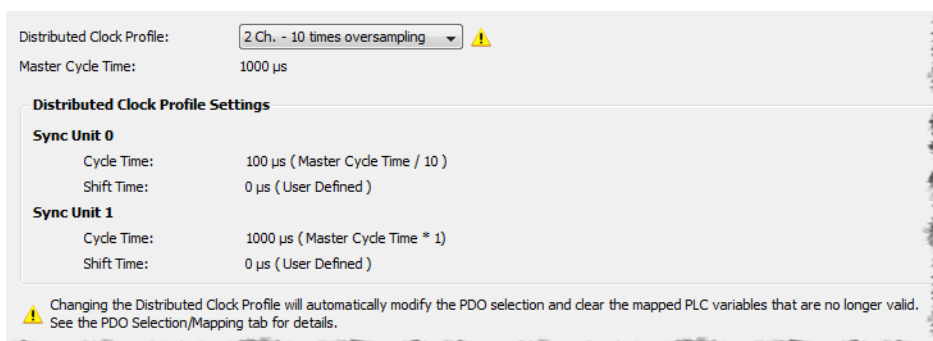





Figure 5-49: Example of a device with oversampling.

Changing the Distributed Clock Profile automatically changes the PDO selection.

- All PDOs corresponding to the selected Distributed Clock Profile and its according oversampling factor are selected.
- These maps are discarded if one or several PLC variables were mapped to a PDO that is no longer selected.

5.12.7 CoE Init Commands tab

This tab lists the EtherCAT device's CoE Init commands. The Init commands are grouped based on the EtherCAT transition state. The sequence within each group defines the order in which the commands are executed on the device.

The order of CoE Init Commands can be changed to define the correct command sequence required for device operation. Selecting a command enables buttons to move a command Up , Down , to the Top of the table , and the Bottom of the table .

NOTE

- This tab is grayed out if the device does not support the CoE Protocol or the ESI file is unavailable.
- Fixed Init-commands have been deprecated and are not listed.

Field	Description
Index	The hex value of the CoE-Index.
Subindex	The CoE-Subindex.
Value	Value of the init command.
Comment	Description of the init command.
Direction	Specifies if the command is Read or Write .
Source	The source of the init command. There are two possible values. <ul style="list-style-type: none"> • ESI File denotes that the command comes from the ESI file. • User denotes that the command is created by the user.

5.12.7.0.1 Functions

Function	Description
Add	Click the Add button to open the Add/Edit CoE Init-Command dialog box. Use the dialog box to create a new Init Command. See "Adding CoE Commands" (→ p. 357) for more information.
Edit	Select an existing Init Command and click the Edit button or double-click the selection to edit the Init Command's attributes. The dialog allows you to edit the command data including the Value , Comment , and Transition .
Delete	Click the Delete button to remove the selected Init Command row.

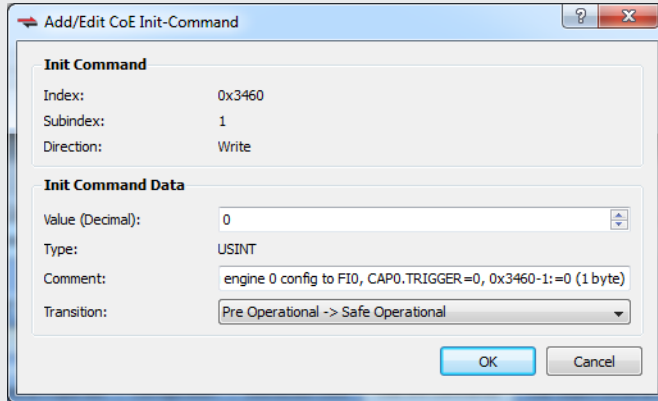

5.12.7.1 Adding CoE Commands

This command allows you to construct a new Init Command by supplying Index, Subindex, Value, Comment, Transition, and Direction attributes.

The dialog lists the device's object dictionary and the objects are filtered based on the **Direction** currently selected, e.g. if "Write" is selected then the Read-only objects are not shown.

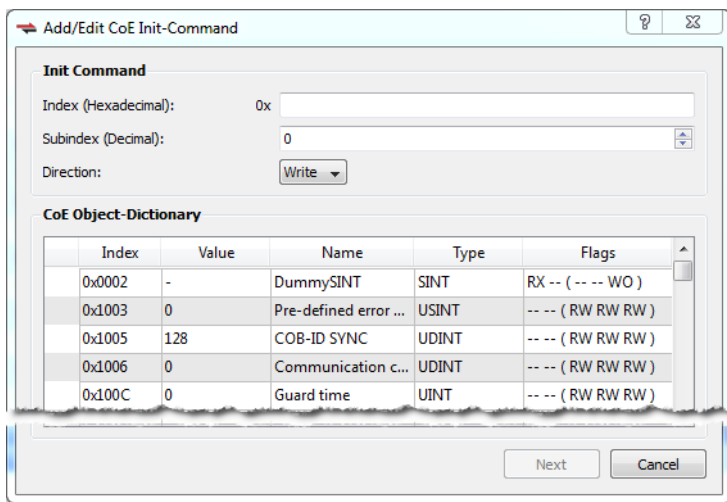

NOTE

- The **Index** field accepts four characters at most.
- The **Subindex** has a range of 0 - 255.
- When setting the Direction you may select **Read** or **Write**.
- Selecting an item in the CoE Object-Dictionary auto-populates the **Index** and **Subindex** entries.

The **Next** button is available once the **Index** and **Subindex** fields have values.

If the Init Command is already present in the dictionary:

If the Init Command is already in the dictionary (i.e. the Index and Subindex you specified are already used) then you are presented with a dialog which allows you to specify the **Value**, a **Comment**, and the **Transition**.

- The Transition may be **Pre Operational -> Safe Operational** or **Safe Operational -> Operational**.
- If the **Type** is "STRING (20)" or "STRING (50)", you may only enter up to 20 or 50 characters.

Clicking **OK** adds the command to the appropriate transition group in the "CoE Init Commands tab" (→ p. 356) and sets the Source attribute to **User**.

The screenshot shows a dialog box titled "Add/Edit CoE Init-Command". It has two main sections: "Init Command" and "Init Command Data".

- Init Command:**
 - Index: 0x0002
 - Subindex: 0
 - Direction: Write
- Init Command Data:**
 - Value (Decimal): 0
 - Type: SINT
 - Comment: DummySINT
 - Transition: Pre Operational -> Safe Operational

At the bottom, there are "OK" and "Cancel" buttons.

If the Init Command data type is an array of bytes, then all the bytes can be entered in HexBinary format in the **Value** text box. The size of the array determines the maximum data that can be entered.

The screenshot shows a dialog box titled "Add/Edit CoE Init-Command". It has two main sections: "Init Command" and "Init Command Data".

- Init Command:**
 - Index: 0x2000
 - Subindex: 3
 - Direction: Read
- Init Command Data:**
 - Value (HexBinary): 00 01
 - Type: ARRAY [0..2] OF BYTE
 - Comment: Reply
 - Transition: Pre Operational -> Safe Operational

At the bottom, there are "OK" and "Cancel" buttons.

If the Init Command is not present in the dictionary:

Adding a new command (i.e. the Index and Subindex are not in the dictionary) presents you with a dialog which allows you to specify a **Value**, **Comment**, and **Transition**.

- The Value must be entered in HexBinary format as shown below.
- The Transition may be **Pre Operational -> Safe Operational** or **Safe Operational -> Operational**.

Clicking **OK** adds the command to the appropriate transition group in the "CoE Init Commands tab" (→ p. 356) and sets the Source attribute to **User**.

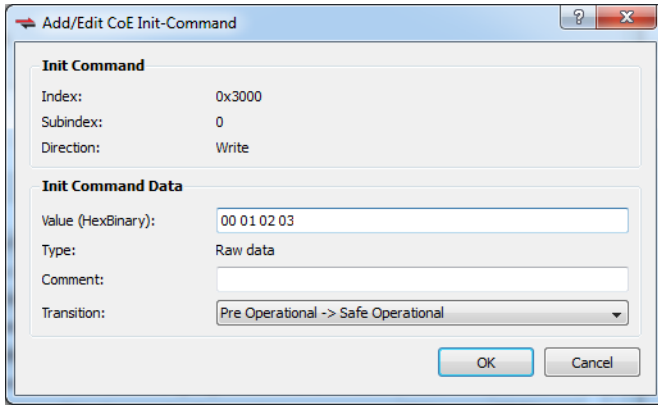

5.12.8 CoE Object Dictionary Tab

This tab displays the all the CoE (CAN over EtherCAT) objects associated with the EtherCAT device. It is used as reference to add new CoE Init Commands for the EtherCAT device. The fields in the table are described below. The CoE objects can be used for three different actions, depending upon the access flags.

- PDO mapping for cyclic communication during application execution
- CoE Init commands during application start-up
- SDO communication during application execution

NOTE

This tab is grayed out if the ESI file does not have CoE object information, or if the file is unavailable.

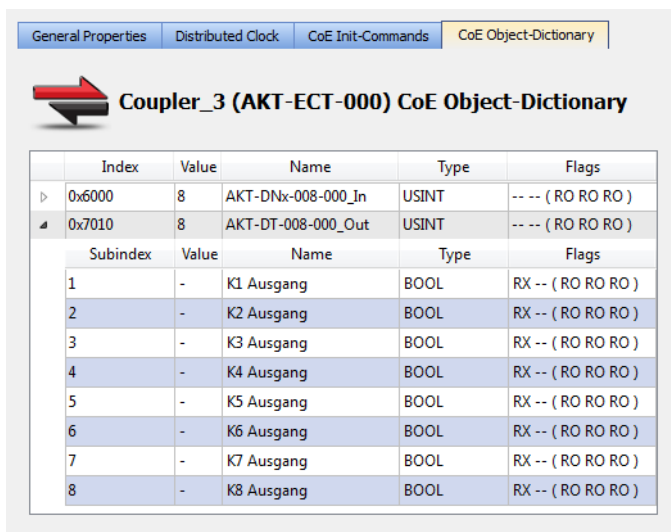

CoE objects can be composed of a simple data type or a complex type. In case of a complex data type, each simple data type composing it has a SubIndex . As shown in the example below, the CoE object can be expanded to show all the subindex's details that are the same as the details for a simple type CoE object.

Index	Name	Value	Type	Flags
0x10F3	Diagnostics: History buffer	5	USINT	--- (RO RO RO)
Subindex Name Value Type Flags				
1	Max. number of messages	32	USINT	--- (RO RO RO)
2	Latest message	0	USINT	--- (RO RO RO)
3	Latest acknowledged message	0	USINT	--- (RW RW RW)
4	New active message	0	USINT	-- TX (RO RO RO)
5	Control bits	0	UINT	--- (RW RW RW)

Field	Description
Index / SubIndex	CoE Index or SubIndex number

Field	Description
Name	Name of the CoE object
Value	Default value of the CoE object
Type	Data type of the CoE object
Flags	<p>This column contains 5 values in the format XX YY (AA BB CC), each representing an access option.</p> <p>The values of XX and YY provide PDO mapping options:</p> <p>XX Specifies if the CoE object can be mapped as RxPDO. It is represented as RX if it can be mapped.</p> <p>YY Specifies if the CoE object can be mapped as TxPDO. It is represented as TX if it can be mapped.</p> <p>The values for AA, BB, and CC provide the CiE Access type. The values can be read only (RO), read-write (RW), or write only (WO)</p> <p>AA Access type of the object in PREOP state</p> <p>BB Access type of the object in SAFEOP state</p> <p>CC Access type of the object in OP state</p>
Module	Name of the module that is associated with the CoE Object

6 Using the KAS Simulator



6.1 Start the KAS Simulator

The **KAS Simulator** is launched from within the KAS-IDE.

Click the KAS Simulator button in the toolbar.

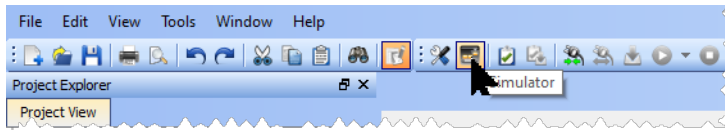

Click the button to:

- Change the KAS project to use KAS Simulator.
- Connect the KAS-IDE to the KAS Simulator.
- Launch the KAS Simulator.

TIP

Each version of KAS-IDE has a matching version of Simulator which it opens. Only one instance of KAS Simulator may be run at a time.

The first time KAS Simulator is run, it attempts to open some TCP/IP ports to allow communication.

The system's firewall detects this and prompts for an action.

NOTE

Simulator normally uses port 80 for the web server.

If another service is using port 80, then Simulator automatically assigns a free port available to the webserver to listen to the incoming HTTP requests.

The port number assigned for the Simulator web server is shown in the status bar.

- If an alternate port is assigned to the web server in the Simulator for HTTP communication, then the HTTP URL should also include the port number to access the web server.
 - Example: In this image, the web server is listening to port 52526. To connect to the Simulator from the web browser, use the URL: `http://127.0.0.1:52526`.

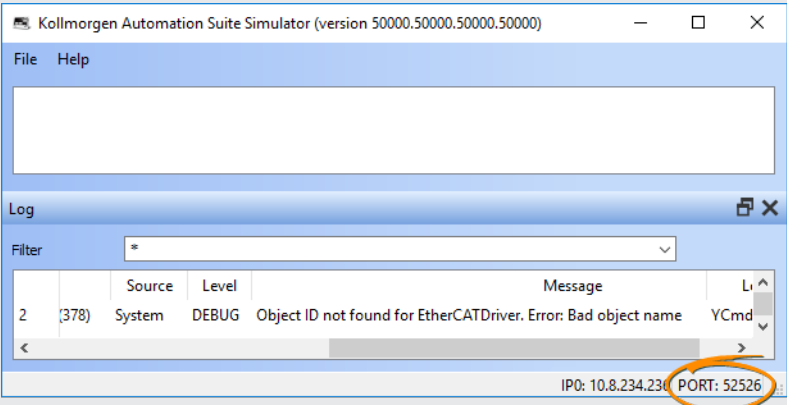

The screenshot shows the Kollmorgen Automation Suite Simulator interface. The Log window is open, displaying a table of log entries. The first entry is highlighted, showing a message: "Object ID not found for EtherCATDriver. Error: Bad object name". The source is "System" and the level is "DEBUG". The IP address is "10.8.234.231" and the port is "PORT: 52526". The port number "52526" is circled in orange.

- Depending on the applications running on the host computer, the alternate port may vary every time the simulator is started.

TIP

Only one instance of Simulator may be used at a time, but multiple instances of the KAS-IDE may be used with the Simulator.

A simple rule to remember is whatever instance is connected to Simulator, owns Simulator.

6.1.1 KAS Runtime Log window

The KAS Runtime Log window provides a running display of activity related to the execution of the application. Items displayed include application startup and initialization information.

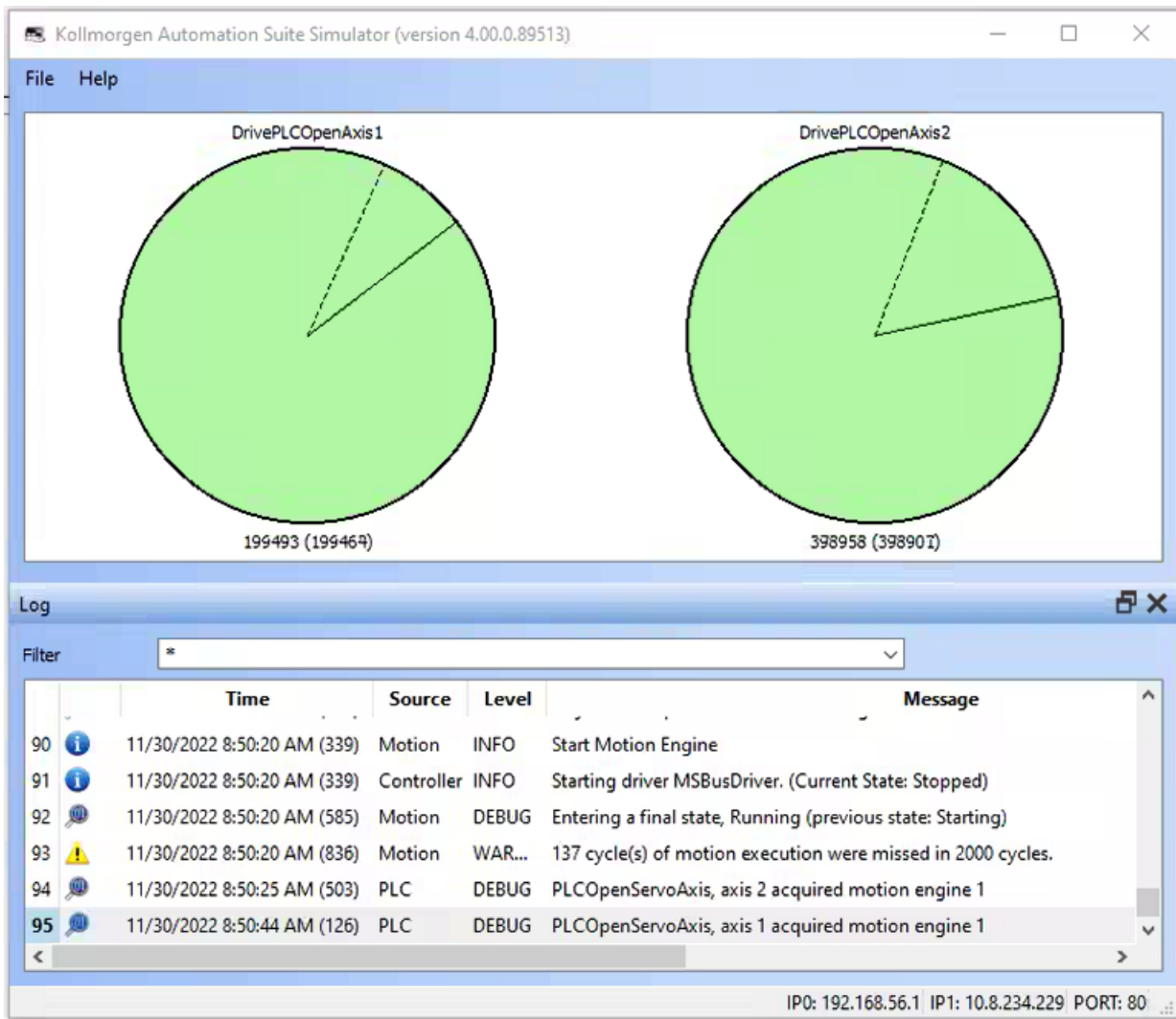

NOTE

Some of the steps performed during the initialization process can be specified in the **initscript.bin** file located under:

C:\Program Files (x86)\Kollmorgen\Kollmorgen Automation Suite\Sinope Simulator\Resources

See also "Log window" (→ p. 366).

6.2 Stop KAS Simulator

The **KAS Simulator** can be closed in several ways:

- From KAS-IDE by clicking the KAS Simulator button in the toolbar.
- Selecting File > Exit.
- Click the Close button at the top right of the KAS Simulator.

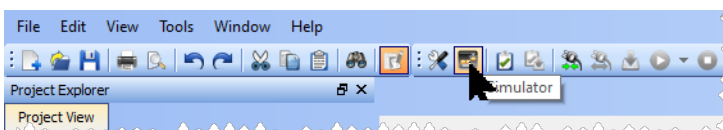

Clicking the KAS Simulator button will perform the following actions.

1. Stop the project if it is running.
2. Disconnect the KAS-IDE from the KAS Simulator.

3. Close the KAS Simulator.
4. Change the project back to using a PxMM as the controller.

Selecting File > Exit or the Close button will stop the project and disconnect the KAS-IDE from the KAS Simulator, but the project will not reset the controller.

TIP

After the project is debugged using KAS Simulator, it can be downloaded to the real controller in production. This operation can be done simply by modifying the IP address of the device and then "Download the Project" (→ p. 228).

TIP

Only one instance of Simulator may be used at a time, but multiple instances of the KAS-IDE may be used with the Simulator. A simple rule to remember is whatever instance is connected to Simulator, owns Simulator.

6.3 KAS Simulator window

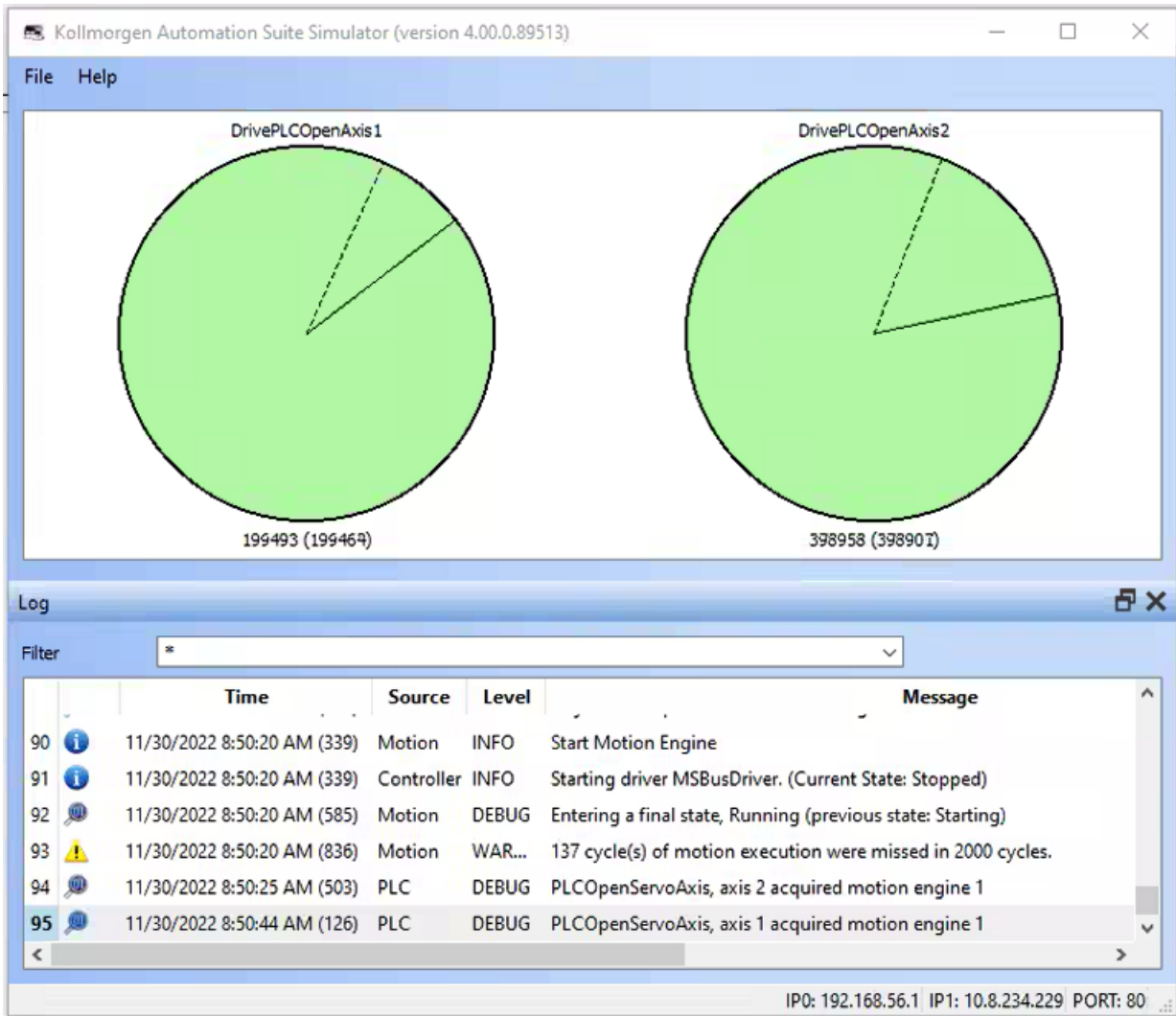

- The dashed line (or dotted line) represents the [Reference Position](#) in User units.
- When the is solid line (or normal line) visible, it represents the [Actual Position](#) in User units.

Below the disk, the reference position for the associated axis is represented in this format:

Range value (**Modulo** value according to the periodicity)

In this image, the **Error** command (in the contextual menu of the axis tab) is used to simulate an error on an axis. Notice the impact on the HMI and implement counter-measures if necessary.

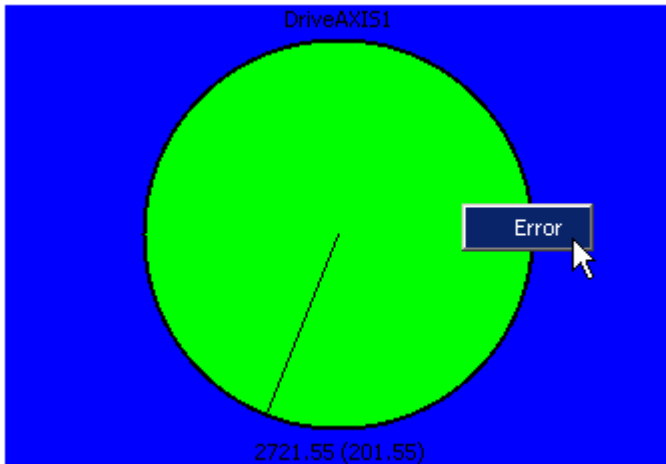

Figure 6-1: Set Axis in **Error** Mode

The drive becomes Red when it is set to **Error** .

See also see "Motion State Machine" on page 738 for more information.

To deselect an axis already selected (blue rectangle), click in the white surrounded outside border of the axis tab.

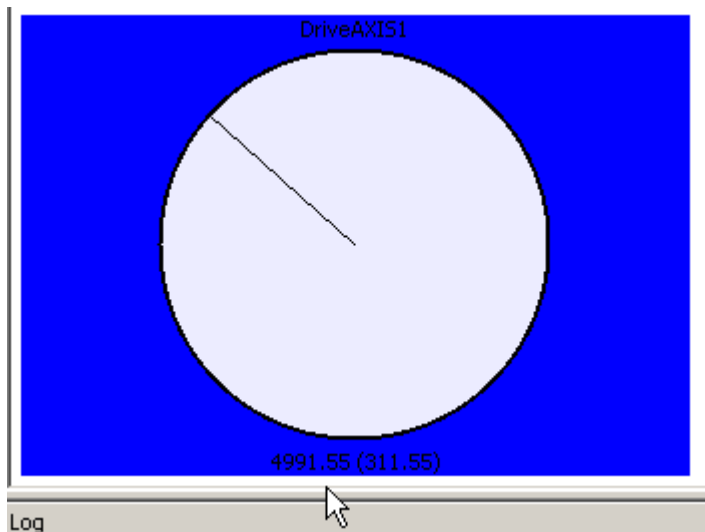

Figure 6-2: Deselect an Axis

6.4 KAS Simulator Graphical User Interface

6.4.1 Main window

KAS Simulator main window contains:

- 1 The menu bar
- 2 The workspace
- 3 The "KAS Runtime Log window" (→ p. 362)

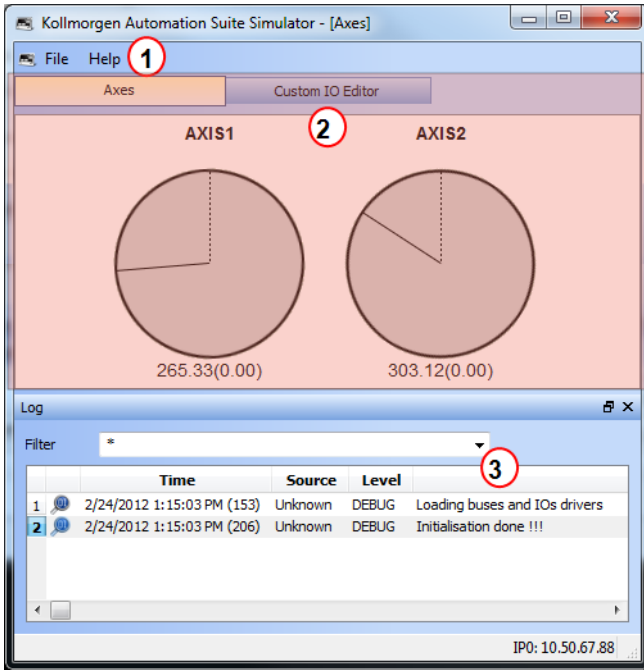

6.4.2 Log window

This Log window shows all log messages related to the KAS Simulator.

Error and warning messages issued from the operating system, and "Printf" (→ p. 235) instructions, are in this window.

Every log message includes:

- Timestamp
- Source
- Logging Level
- Message

6.5 KAS Simulator Menus Description

6.5.1 File Menu

Command	Description
Start	Start the application with the "Retain Variables" (→ p. 707).
Cold Start	Start the application with the initial settings.
Stop	Stop the application.
Option	Set parameters for the KAS Simulator application (see explanations below).
Exit	Leave KAS Simulator application.

Option

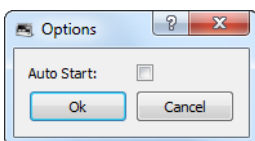

Option	Description
Autostart	Autostart the application when KAS Simulator is launched. Autostart mode is recommended when a system is in production.

NOTE

Parameters are saved in the **Options.bin** file located under:
<user>\AppData\Local\Kollmorgen\KAS\Sinope Simulator\Resources\

6.5.2 Help Menu

Command	Description
About	Show version numbers and other "Find the KAS-IDE Version" (→ p. 130) about KAS Simulator

7 Migrate from a PxMM to a PCMM2G Controller

NOTE

This procedure is intended for users with AKD PDMM or PCMM (PxMM) experience.

These are the basic steps to migrate data from a PxMM to a PCMM2G Controller.

- A. "Prepare the User .KAS Project for Migration" (→ p. 368)
- B. "PCMM2G Hardware Preparation" (→ p. 368)
- C. "PCMM2G Configuration" (→ p. 370)
- D. "User .KAS Project Migration" (→ p. 371)

7.1 Prepare the User .KAS Project for Migration

1. Download and install the latest KAS-IDE software from here: [KAS IDE Distribution](#).
2. Download the latest PxMM firmware.
 - AKD PDMM: [AKD PDMM Firmware / Software Download](#).
 - PCMM: [PCMM Firmware / Software Download](#).
3. Use the Web server to complete the "Upgrade the Controller's Firmware" (→ p. 423) procedure.
4. **Backup the .KAS project to migrate.**
We recommend you make a backup copy of your .KAS project so any project or code changes can be verified independently.
5. "Start the KAS-IDE" (→ p. 130).
6. Click **File > Open** to search for and open the .KAS project.
7. Review and make code changes to the project code to be compliant with the "Program a Multi-Core Controller" (→ p. 784) guidelines.
8. Compile and download the .KAS project to the PxMM.
9. "Run the Project" (→ p. 222) and verify it is working as expected.
10. Save the .KAS project.
11. Continue with "PCMM2G Hardware Preparation" (→ p. 368).

7.2 PCMM2G Hardware Preparation

[Click to view the PCMM2G Hardware Connections](#)

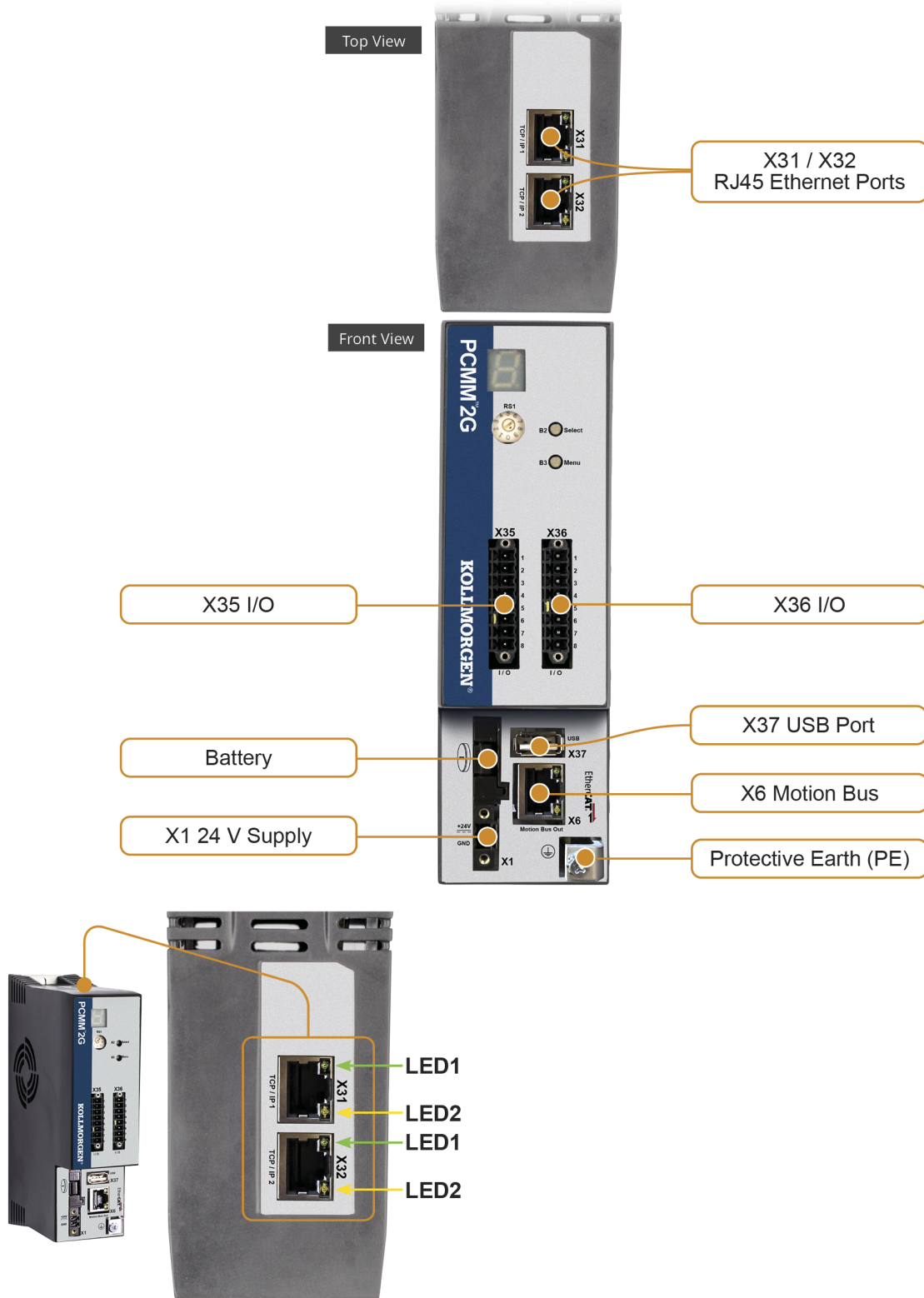

Figure 7-1: PCMM2G Hardware Connections

1. **Verify the PCMM2G is turned off.**
2. PCMM2G-specific settings:
 - a. Connect the service interface (X31 or X32) of the PCMM2G to an Ethernet interface on the PC directly or use a network hub/switch.

- Use standard Cat. 5e / Cat. 6 Ethernet cables for connection.
- b. Insert the USB flash drive into X37.
- 3. Hardware settings similar to the PxMM:
 - a. Set the Rotary Switch RS1 to the applicable position.
 - b. Move these cables from the PxMM to the PCMM2G:
 - X35 and X36 I/O port.
 - X6 EtherCAT Motion Bus port.
 - c. Attach a 24V_{DC} power supply connection to X1 to power on the PCMM2G.
The "PCMM2G Boot Sequence" (→ p. 378) starts.
- 4. Confirm the X31 or X32 LED1 on the PCMM2G are green.
- 5. Continue with "PCMM2G Configuration" (→ p. 370).

7.3 PCMM2G Configuration

1. Identify the PCMM2G's IP address.
See "View the Controller IP Address" (→ p. 384) for more information.
2. Open a web browser and enter the controller's IP address.
The PCMM2G's Web server opens.
3. Click the **LOGIN** link at the top of the window.
4. Enter the password to log in.
The factory default password is `administrator`.
This can be changed after logging in.
5. Click the "Settings tab" (→ p. 415).

[Click to see the Settings tab](#)



A REGAL REXNORD BRAND

[LOGIN](#) | [HOME](#) | [CONTACT US](#) | [ABOUT](#)

KAS Application

Settings

Backup & Restore

Diagnostics

Help



Settings

Note that most of the following features are not available when PLC application is running or online config mode is active

Firmware

Date/Time

Network

File System

USB Flash Drive

User Account

Firmware Information

OS version	1.0.0.00351
Runtime version	4.01.0.92341
Recommended file name	<i>KAS-PCMM2G-Cx-08-OS-{OS version}-RT-{Runtime version}.zip</i>

Firmware Upgrade

Firmware image file ⁽¹⁾ Choose File No file chosen

Upgrade
Reboot

1. Select the new firmware image (.zip) file⁽¹⁾.
2. Click Upgrade to start the updating procedure
3. PCMM2G reboots with the new firmware automatically
4. Press CTRL+F5 to force a page refresh.

⁽¹⁾Firmware images are available at Kollmorgen.com
The .zip file may contain an operating system update file (*.swu), a KAS runtime update file (*.tgz), or both.



A REGAL REXNORD BRAND

Kollmorgen
 203A West Rock Road
 Radford, VA 24141 USA

© Copyright 2023 Kollmorgen. All rights reserved.

6. On the "Firmware tab" (→ p. 422), complete the "Upgrade the Controller's Firmware" (→ p. 423) procedure.
7. On the "Date/Time tab" (→ p. 417), edit the date, time, and time zone.

Notes about the Date/Time tab

- By default, the NTP Server is selected for the Date/Time.
 - The Date/Time can be manually changed using the "Update Date/Time" (→ p. 419) procedure.
 - A Time Zone must be assigned to the PCMM2G.
- 8. If the PCMM2G Rotary Switch RS1 is set to 1, use the "Network tab" (→ p. 431) to manually define the IP address.
- 9. Continue with "User .KAS Project Migration" (→ p. 371).

7.4 User .KAS Project Migration

1. In the KAS-IDE, click **File > Open** to search for and open the .KAS project saved in the "Prepare the User .KAS Project for Migration" (→ p. 368) procedure.

2. In the **Project View** panel, right-click **Controller** and click **Properties**. The **Controller Properties** dialog opens.

[Click to see the Controller Properties dialog](#)

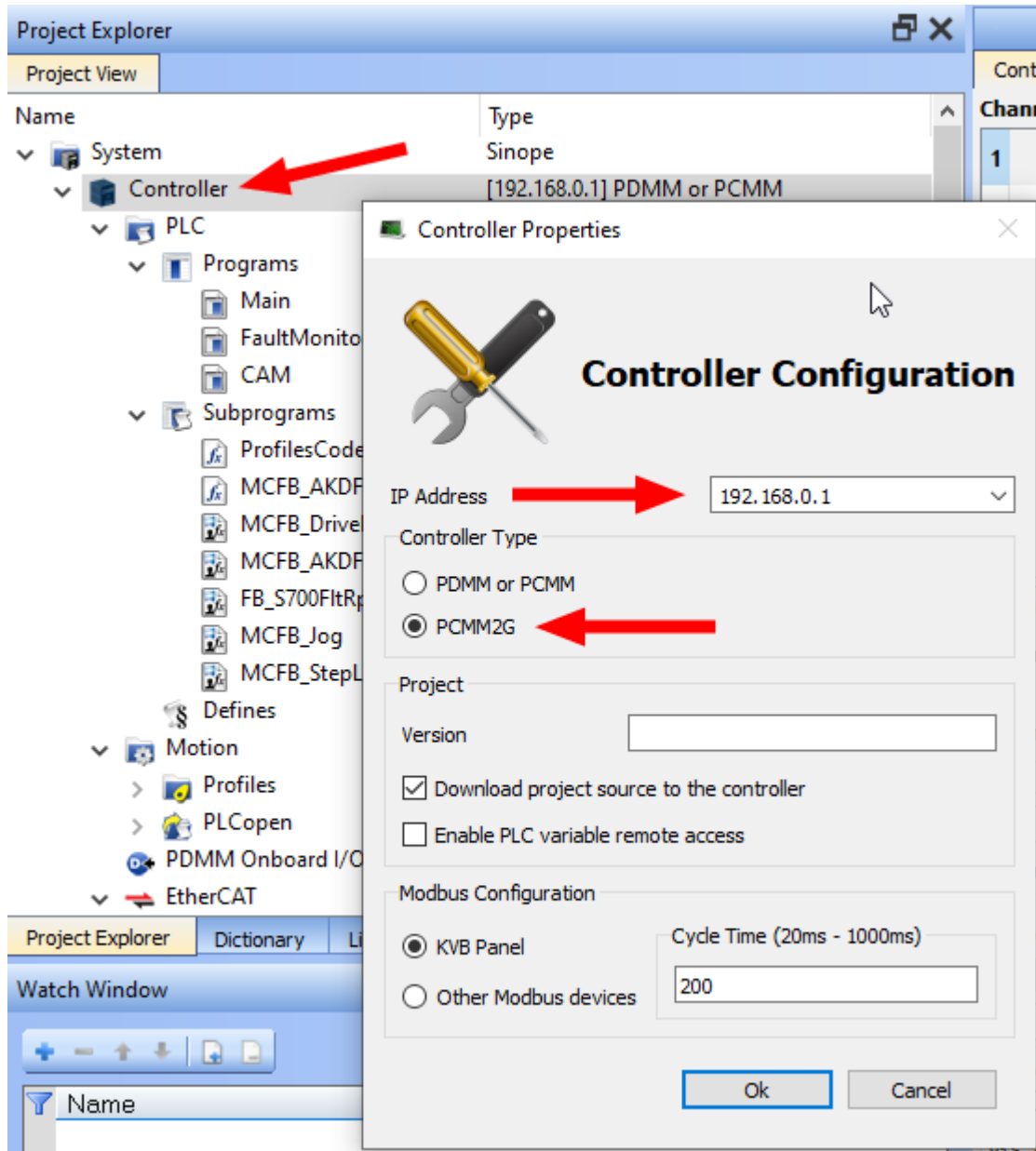

3. Configure the PCMM2G:
 - a. In the **IP address** drop-down, enter the PCMM2G IP address.
 - b. In the **Controller Type** area, select the **PCMM2G** option button.
 - c. Click **OK** to save the changes or selections and close the dialog.
4. If using the SD card in the PCMM.KAS project:
 - a. Locate and change the file management functions using the SD card file paths to use the USB flash drive file paths.
See File Management, SD Card Path Conventions, and USB Flash Drive Path Conventions.

NOTE

On a PxMM1G, the user data is stored in either the **SD card**, internal flash, or a shared directory. On a PCMM2G, the user data is stored in either the **USB flash drive**, internal flash, or shared directory.

[Click to view example code to keep a .KAS project compatible between PxMM1G and PCMM2G](#)

NOTE

This example code chooses the SD Card or USB Flash drive file path depending on the controller model.

```
// Get the controller model details once at application startup
g_ControllerFamily := CTRLINFO_MODEL_FAMILY_PxMM;
Inst_GetCtrlInfo( TRUE, CTRLINFO_MODEL_FAMILY );
IF Inst_GetCtrlInfo.Done THEN
    g_ControllerFamily := any_to_int(Inst_GetCtrlInfo.Value);
END_IF;
Inst_GetCtrlInfo( FALSE, CTRLINFO_MODEL_FAMILY );
// Set the file path prefix based on the controller model (SD Card or
USB Flash Drive)
CASE g_ControllerFamily OF
CTRLINFO_MODEL_FAMILY_PCMM2G:
    UserFilePathPrefix := '//usbflash/';
CTRLINFO_MODEL_FAMILY_PxMM:
    UserFilePathPrefix := '//SDCard/';
END_CASE;
// File management operations
TestFile := UserFilePathPrefix + 'test_file.txt';
Inst_FileOpenW( TRUE, TestFile);
IF Inst_FileOpenW.Done THEN
    dataFileID := Inst_FileOpenW.ID;
    Inst_FileOpenW( FALSE, TestFile );
END_IF;
```

5. Compile and download the .KAS project to the PCMM2G.
6. "Run the Project" (→ p. 222) and verify it is working as expected.
7. Save the .KAS project.
Optional: Click **File > Save As** to save the .KAS project with a different name.
8. Use the Web server to complete the "PCMM2G Controller and EtherCAT Devices Backup" (→ p. 436) procedure.

8 Using the Controllers



Tasks related to the Kollmorgen controllers are:

- Configure parameters.
- Start and stop the KAS application.
- Update the firmware.
- Reset to factory settings.
- Review of "Controller Error and Alarm Descriptions" (→ p. 668).

Rebooting or resetting the controller and recovering the firmware can be performed from the device or using the Web server.

NOTE

Unless otherwise noted, any reference to AKD PDMM or PCMM refers to both the 800MHz and the single- and dual-core 1.2GHz variants.

8.1 Booting the AKD PDMM or PCMM Controller

This topic explains the boot sequence for the controller, which is based on the RAM and the Flash memory.

The flash memory contains two images:

- Recovery image (4 Mb) contains QNX operating system and the KAS web server.
- Regular image (9 Mb) contains QNX operating system, the KAS web server, and the KAS Runtime.

See Also

- "Boot from Recovery Image (B2 Button)" (→ p. 384)
- "Controller Boot Startup Script" (→ p. 380)

8.2 Booting the PCMM2G Controller

This topic explains the boot sequence for the PCMM2G controller.

The PCMM2G controller contains these partitions: **Active**, **Boot**, **Data**, and **Inactive**.

- "Active Partition" (→ p. 375)
- "Boot Partition" (→ p. 375)
- "Data Partition" (→ p. 375)
- "Inactive Partition" (→ p. 375)

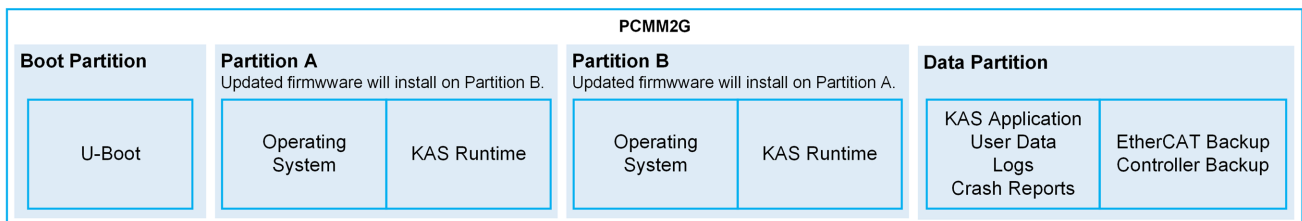
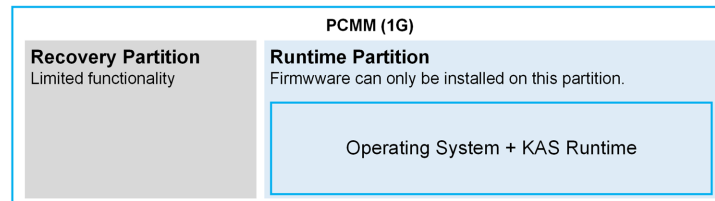

Figure 8-1: PCMM and PCMM2G Partitions

8.2.1 Active Partition

- The **Active** partition:
 - Contains the entire operating system and the KAS Runtime.
 - Is where the controller is currently booted from.
 - It contains the current version of the operating system and KAS Runtime.
 - When the user downloads a new version of firmware, it is loaded onto the **Inactive** partition.
 - When the loading is complete, the controller reboots to the **Inactive** partition, making it the new **Active** partition.
- If the **Active** partition cannot boot up to an operable state, the controller can boot up a USB flash drive containing a recovery image.

8.2.2 Boot Partition

- The **Boot** partition contains the U-Boot, a universal bootloader.
 - The bootloader initializes the hardware and loads the operating system.

8.2.3 Data Partition

- The **Data** partition contains the:
 - KAS application, user data, logs, and crash reports.
 - EtherCAT and controller backup files.

8.2.4 Inactive Partition

- The **Inactive** partition:
 - Contains the entire operating system and the KAS Runtime.
 - Serves as a fallback.
 - If booting up the **Active** partition fails, the controller attempts to boot up from the **Inactive** partition.
- If the **Inactive** partition cannot boot up to an operable state, the controller can boot up from a USB flash drive containing a recovery image.
- The user can force booting up from the inactive partition by holding the B3 button in while powering on the controller.
 - This is one recourse to use if the controller does not become operational when booting off from the active partition.

See "Boot from Inactive Partition Image - PCMM2G" (→ p. 376) for more information.

See Also

- "Boot from Recovery Image (B2 Button)" (→ p. 384)
- "Controller Boot Startup Script" (→ p. 380)
- "Boot Sequence" (→ p. 377)

8.3 Boot from Inactive Partition Image - PCMM2G

The PCMM2G controller contains two versions of the firmware stored in the non-volatile storage (flash memory).

8.3.0.1 Operational Image

This is the firmware version that was last downloaded is stored in the primary partition.

8.3.0.2 Fallback Image

This is the firmware version downloaded prior to that is stored in the inactive partition.

NOTE

See "Boot the PCMM2G Controller" (→ p. 375) about the partitions in the PCMM2G non-volatile storage.

8.3.1 Boot Failure

In rare situations, the controller might be unable to boot into operational firmware.

Examples: A failure could be caused by:

- Corruption of the flash memory containing the firmware image.
- A critical error early in the boot process.

Although Kollmorgen tries to ensure these failures never happen, the possibility requires a recovery mechanism to allow a working firmware image to be programmed.

8.3.2 Fallback Mode

Drastic failures of the operational firmware (i.e., those that cause the firmware to crash) trigger an automatic reboot into the fallback firmware image.

- An automatic reboot into the Fallback Mode does **not** happen when a critical error occurs early in the boot sequence.
 - This is a rare occurrence.
- The 7-segment display is stuck showing either 2 or 3.
 - It is possible for users to explicitly boot the controller into the Fallback Mode.

8.3.2.1 Boot into Fallback Mode

To explicitly boot into **Fallback Mode**, press and hold B3 button when powering up the controller.

- The goal of running a **Fallback** image is to recover the controller by downloading working operational firmware.
- The 7-segment display on the controller reports an "E60" (→ p. 679) () error when the controller has booted up in **Fallback Mode**.

8.3.3 Limitations

There are some limitations to the system when the controller is running from the **Inactive** partition.

- The auto-start option for the KAS application is not supported.
 - The user must start the KAS application manually every time after the controller is powered up.
- An "E60" (→ p. 679) error is reported to indicate the active partition is corrupted.
 - This error is cleared when a new firmware is downloaded or restored using the previously taken controller backup.
 - See either the "Firmware tab" (→ p. 422) or "Restore tab" (→ p. 439).

Notes

ⓘ IMPORTANT

It is strongly recommended to upgrade firmware again to have the same firmware version on the **Active** and **Inactive** partitions.

The KAS application remains compatible when the controller is operating with the same firmware version on the Active and Inactive partition.

- If the **Active** partition becomes corrupted, the controller runs from the **Inactive** partition.
 - If the firmware is **the same** on the **Active** and **Inactive** partitions, the KAS application runs correctly.
 - This avoids the need for the users to compile and download the KAS application to keep the machine running.
 - The user has time to download new firmware for resolving the corruption in the **Active** partition.
 - If the firmware is **not the same** on the **Active** and **Inactive** partitions, the KAS application does not work.
 - Failure Correction: On the **Inactive** partition, download and compile the firmware that is on the **Active** partition.

8.3.4 Recovery Mode

In the rare event the **Fallback** image stored in the flash memory does not work either, the controller can boot into Recovery Mode using the USB flash drive.

A binary image that boots the controller from the USB flash drive is provided with the firmware release.

See "PCMM2G Web server Recovery" (→ p. 429) about how to recover the controller from the USB flash drive.

8.4 Boot Sequence

NOTE



The controller may be booted with or without an Ethernet cable attached.

These are the controller boot sequences:

- "AKD PDMM or PCMM Boot Sequence" (→ p. 378)
- "PCMM2G Boot Sequence" (→ p. 378)
 - "Internal Flash" (→ p. 378)
 - "Recovery USB Drive" (→ p. 379)









When the controller is booted with a cable attached, the configured IP address (depending upon the current position of the rotary switch) appears in the 7-segment display.

- See "View the Controller IP Address" (→ p. 384) for more information.
- If the controller is started without a network connection then the IP address is not displayed.
- After the boot sequence is successful, the controller is in one of two modes:

	Normal operation.
	Recovery Mode (if firmware download is permitted).

8.4.1 AKD PDMM or PCMM Boot Sequence

This is the boot sequence for either the AKD PDMM or PCMM:

State	Display	Description
Hardware Power ON		The controller option card has power.
Stage 0		This is reached after the I ² C is initialized.
Stage 1		This is reached after the DDR3 ram memory is initialized.
Stage 2		This is reached just after the RAM memory relocation. At this point the boot is running in DDR3 RAM memory.
Stage 3		Reached after the flash memory is initialized.
"Controller Boot Startup Script" (→ p. 380)		After all the previous steps, the startup script starts automatically.
QNX startup		This is reached after the Boot startup script is finished.
Sysinit		This is reached after: <ul style="list-style-type: none"> • Specific configuration parameters of the target are loaded. • The network is started using the "Controller Rotary Switch" (→ p. 60).

8.4.2 PCMM2G Boot Sequence







These are the boot sequences of the PCMM2G:

- "Internal Flash" (→ p. 378)
- "Recovery USB Drive" (→ p. 379)

8.4.2.1 Internal Flash

NOTE

If the controller is stuck in Stages 1 to 4, then recovery could be made by using the B3 button to boot off of the inactive partition.
See "Boot from Inactive Partition Image - PCMM2G" (→ p. 376).

State	Display	Description
Hardware Power ON		PCMM2G has power.
Stage 1		Bootloader completed. Starting U-Boot.
Stage 2		U-Boot succeeded. Starting Linux Kernel.
Stage 3		Linux Kernel is up. PCMM2G processes Initializing.
Stage 4		Starting: <ul style="list-style-type: none"> • KAS Runtime process monitor. • KAS Runtime.
Final Stage		Runtime started.







8.4.2.2 Recovery USB Drive

See "PCMM2G Web server Recovery" (→ p. 429).

NOTE

If the controller is stuck in Stages 1 to 4, then recovery could be made by using the B2 button to boot off of the recovery USB drive.

See "Boot from Recovery Image (B2 Button)" (→ p. 384).

State	Display	Description
Hardware Power ON		PCMM2G has power.
Stage 1		Starting U-Boot from recovery USB drive.
Stage 2		U-Boot succeeded. Starting Linux Kernel.
Stage 3		Linux Kernel is up. PCMM2G processes Initializing.
Stage 4		Starting: <ul style="list-style-type: none"> • KAS Runtime process monitor. • KAS Runtime.
Final Stage		Recovery runtime started.

8.5 Boot from Recovery Image (B2 Button)

NOTE

For PCMM2G: Insert the Recovery USB flash drive into X37 USB Port of the PCMM2G before holding the B2 button during boot sequence.
See "PCMM2G Web server Recovery" (→ p. 429).

8.5.1 AKD PDMM and PCMM Only

To enter recovery mode, press and hold B2 during the boot sequence before the Boot Startup Script runs.

See "AKD PDMM and PCMM Web server Recovery" (→ p. 428).

- When the system detects that the button is pressed, it enters Recovery Mode. The 7-segment display shows a lower-case **r**.



- While in Recovery Mode, the AKD PDMM, PCMM, or PCMM2G downloads the firmware from the recovery image.
 - When the firmware is being written to the flash drive, the 7-segment display animates.
- Do not power-off the system during this process.



(repeats).

- When the download is complete, the controller goes into normal operation.
 - If the download or write to flash fails, the 7-segment display shows a numeric error.
 - See "Errors" (→ p. 668) for more information.

NOTE

The controller displays a backward **C** on the 7-segment display if the wrong firmware is installed. You must enter recovery mode to load the correct firmware file.

See Also

- "Booting the AKD PDMM or PCMM Controller" (→ p. 374)
- "Booting the PCMM2G Controller" (→ p. 375)

8.6 Controller Boot Startup Script

- After all the previous steps, the startup script starts automatically.
 - The script puts the 7-segment display into Stage 4.
- Before the controller boots up, this flowchart applies to their respective controller.

8.6.1 AKD PDMM and PCMM Flow

See "Booting the AKD PDMM or PCMM Controller" (→ p. 374) for more information.

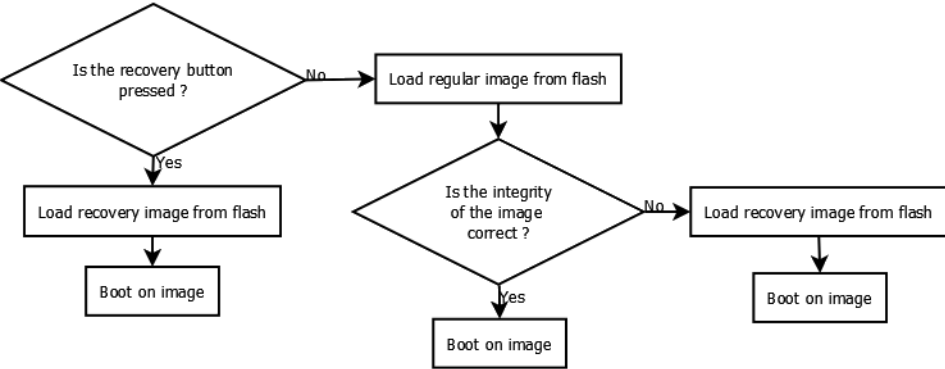

Figure 8-2: AKD PDMM and PCMM Flow

8.6.2 PCMM2G Flow

See "Booting the PCMM2G Controller" (→ p. 375) for more information.

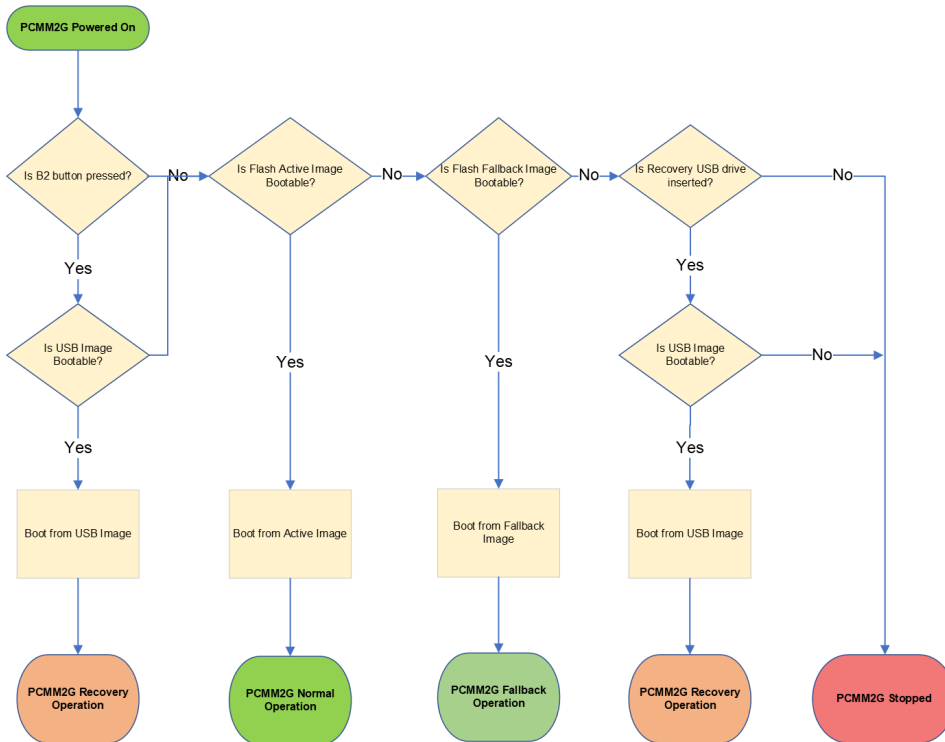

Figure 8-3: PCMM2G Flow

8.7 Use the Controller Buttons

In some cases, using the buttons on the controller is preferable to using the Web server.

On the front of the controller there are two buttons: B2 and B3.

- These buttons are used to:
 - Enter Recovery Mode.
 - See "Boot from Recovery Image (B2 Button)" (→ p. 384).
 - "View the Controller IP Address" (→ p. 384).
 - Stop and start the application.
 - Reset the controller to factory settings.
 - See "Reset the Controller to Factory Settings" (→ p. 385).
 - AKD PDMM and PCMM only: Backup / Restore the firmware.
 - See "Controller Backup and Restore" (→ p. 387).
 - PCMM2G only: "Boot from Inactive Partition Image - PCMM2G" (→ p. 376).

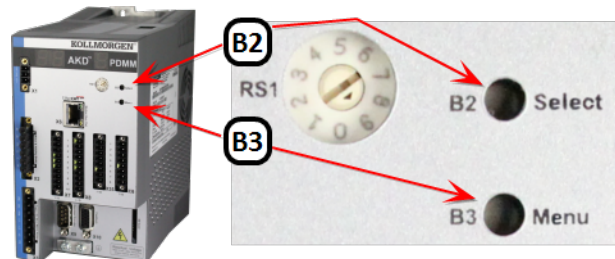

8.7.1 Button Functionality

8.7.1.1 Power-up

Press and Hold	Result
B2	"Boot from Recovery Image (B2 Button)" (→ p. 384)
B3	PCMM2Gonly: "Fallback Mode" (→ p. 376)

NOTE

Press the B2 or B3 button before the Hardware Power ON stage () begins. Hold at least until the controller reaches the Stage 2 during the "Boot Sequence" (→ p. 377).

8.7.1.2 Running

Press	Result
B2	Menu option selector
B3	"B3 Menu Button" (→ p. 383)

8.7.2 B3 Menu Button

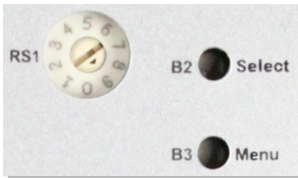

The B3 menu push-button cycles through a list of menu items displayed on the 7-segment display.

8.7.2.0.1 Access Functions Menu

- Press and hold the B3 button during the boot sequence.
 - Each B3 press advances to the next menu item.
 - The menu item is displayed for 10 seconds. If no button is pressed within the 10 seconds, the 7-segment display returns to Normal operation.
- Press the B2 button to select the current menu item.

8.7.2.1 Application is Running

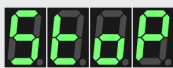
Functionality	Display	Notes
Display the IP		See "View the Controller IP Address" (→ p. 384) for more information.
Stop the application		This stops the KAS Runtime.

8.7.2.2 Application is Not Running

Functionality	Display	Notes
Display the IP		See "View the Controller IP Address" (→ p. 384) for more information.

Functionality	Display	Notes
Start the application		This starts the KAS Runtime.
Factory Reset		See "Reset the Controller to Factory Settings" (→ p. 385).
Backup firmware to SD card		See "B3 Button Backup" (→ p. 389). Applies only to the AKD PDMM and PCMM, not PCMM2G.
Restore firmware from SD card		See "B3 Button Restore" (→ p. 389). Applies only to the AKD PDMM and PCMM, not PCMM2G.

NOTE

When selected, the **Start**, **Stop**, **Backup**, **Restore**, and **Reset** functions do not initiate immediately; they require confirmation. The 7-segment display flashes a **y**, prompting for confirmation. Press B2 to confirm the function and begin the process. If the function is not confirmed within 10 seconds, the action is canceled.



8.7.3 View the Controller IP Address

The IP address assigned to the controller is shown in the 7-segment display.

- The IP address is shown at boot and can be accessed from the "B3 Menu Button" (→ p. 383).
- The default IP address depends on the Rotary Switch RS1 position.

Example



Figure 8-4: IP sequence of the 7-segment display

NOTE

The AKD PDMM and PCMM do not set (or show) an IP address without an attached network cable. On the PCMM2G, if a network cable is not attached or no IP address is assigned, the controller shows an IP address of 0.0.0.0.

8.7.4 Boot from Recovery Image (B2 Button)

NOTE

For PCMM2G: Insert the Recovery USB flash drive into X37 USB Port of the PCMM2G before holding the B2 button during boot sequence. See "PCMM2G Web server Recovery" (→ p. 429).

8.7.4.1 AKD PDMM and PCMM Only

To enter recovery mode, press and hold B2 during the boot sequence before the Boot Startup Script runs.

See "AKD PDMM and PCMM Web server Recovery" (→ p. 428).

- When the system detects that the button is pressed, it enters Recovery Mode. The 7-segment display shows a lower-case **r**.



- While in Recovery Mode, the AKD PDMM, PCMM, or PCMM2G downloads the firmware from the recovery image.
 - When the firmware is being written to the flash drive, the 7-segment display animates.
- Do not power-off the system during this process.



(repeats).

- When the download is complete, the controller goes into normal operation.
 - If the download or write to flash fails, the 7-segment display shows a numeric error.
 - See "Errors" (→ p. 668) for more information.

NOTE

The controller displays a backward **C** on the 7-segment display if the wrong firmware is installed. You must enter recovery mode to load the correct firmware file.

See Also

- "Booting the AKD PDMM or PCMM Controller" (→ p. 374)
- "Booting the PCMM2G Controller" (→ p. 375)

8.7.5 Reset the Controller to Factory Settings

⚠ WARNING

Performing a factory reset of the controller should be considered very carefully.

The reset erases everything: User data files, the application, the controller IP address, any retain variables, passwords, shared directory settings, and all log files.

The reset is performed using these methods:

- From the "File System tab" (→ p. 421) of the Web server while the drive is running.
 - This method is recommended due to its ease of use.
- Selecting the function from the "B3 Menu Button" (→ p. 383).
 - This can be done during the boot sequence or while the drive is running.

After two seconds (or longer if pressed during power-up), the 7-segment display on the controller is changed to an animation pattern indicating the factory reset has started.



After the factory reset is complete, the controller is powered down and restarted automatically.

8.7.5.1 Factory Reset Changes

The changes which occur during a reset are:

Erased Items

- User data files.
- Any application previously downloaded.
- Retained variables.
- Shared directory settings.
- Log files.

Defaults Restored

- Password for both the web page and SSH login.
 - See "SSH Login to a Controller" (→ p. 400) and "User Authentication" (→ p. 406).
- Controller network configuration.
 - Examples: IP address, Subnet, and Gateway settings.
- Auto-Start option.

PCMM2G Only

- The SSH keys are regenerated.
 - SSH clients logged on during the factory reset are forced to log in again.
 - All Date and Time settings are reset to default (NTP enabled).



Notes

- The factory reset cannot be performed while an application is running.
- Do not turn off the controller during the reset procedure.
- If the AKD PDMM or PCMM has just been powered up, the B3 button must be held down much longer than 2 seconds.
 - In this case, hold down the button until the 7-segment display shows the B3 menu.
 - See "B3 Menu Button" (→ p. 383).
- Estimated time for factory reset:
 - AKD PDMM and PCMM: 4-5 minutes.
 - PCMM2G: About a minute.
 - The 7-segment display on the controller is animated during this process.
- After the factory reset is complete, the controller is powered down and restarted automatically.
- After the controller is restarted, the controller IP address may change based on the controls rotary switch.
 - If the rotary switch is at position 0 (zero), the same IP address as before should be assigned to the controller.
 - If the rotary switch is set to 1-9, a pre-configured IP address is defined.
 - This IP address must be taken into account when trying to reconnect to the webpage using a web browser.

8.7.5.2 Reset Controller While the Drive is Running

A reset may be done any time after the controller is powered on and an application is not running.

The reset is ignored if an application is running on the controller .

	<p>Normal Operation</p>	<p>Press the B2 button to access the menu. Use the B3 button scroll to the Reset option in the menu. Press B2 to confirm the reset to factory defaults.</p>
	<p>Program Running</p>	<p>Reset to factory defaults is not permitted. The Reset menu item is not available.</p>

8.7.6 SD Card Support

The AKD PDMM and PCMM controllers support using an SD card for backup and restore functionality.

- This lets you manage the configuration, application and operation data.
- The controller has an SD card slot and push buttons (B2 and B3) which activate file transfers to and from an SD card.

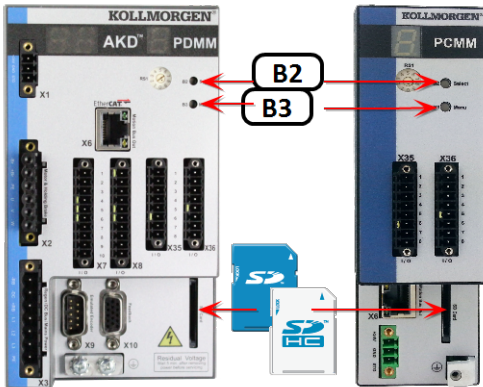

Use the SD card to:

- Backup and restore a controller configuration.
- Store and retrieve an application, including source code.
- Store and retrieve user data from an application or PC.

8.7.6.1 Supported SD Card Formats

Format	File System	Capacity
SD (SDSC)	FAT16 [‡] or FAT32	2GB
SDHC	FAT32 [‡]	4-32GB

[‡] The default file system for the format.

ⓘ IMPORTANT

We recommend using an SD card rated to a 85 °C maximum operating temperature. SD cards which do not meet this criteria should not be left in the device.

8.7.7 Controller Backup and Restore

The Backup and Restore functions are used to replicate a Kollmorgen controller.

The controller data is replicated on these storage devices:

- AKD PDMM and PCMM: SD card.
- PCMM2G: USB flash drive.

8.7.7.1 Backup

Backup is performed with one of these methods:

- Use the web server.

- This is recommended because it has functionality the button method does not offer (e.g., back up the drive data).
 - See "Backup and Restore from the Web server" (→ p. 434) for more information.
- Use the "B3 Menu Button" (→ p. 383) on the front of the controller.
 - See "B3 Button Backup" (→ p. 389) for more information.
 - PCMM2G: Currently does not support controller backup using the B3 menu button.

TIP

For a complete backup of both the controller and drive, use the Web Server backup.

8.7.7.2 Restore

Restoring information to the controller is performed with one of these methods. Both methods restore the controller (and AKD PDMM drive) with whatever was saved to the SD card.

- Use the web server.
 - See "Backup and Restore from the Web server" (→ p. 434) for more information.
- Use the B3 button menu on the front of the controller.
 - See "B3 Button Restore" (→ p. 389) for more information.
 - PCMM2G: Currently does not support controller restore using the B3 menu button.

Backup & Restore What?	AKD PDMM / PCMM To/From SD card via B2/B3 buttons	AKD PDMM / PCMM To/From SD card via Web server	PCMM2G To/From USB flash drive via B2/B3 buttons	PCMM2G To/From USB flash drive via Web server
Controller: Firmware	✓	✓	✗	✓
Controller: Network Configuration	✓	✓	✗	✓
Controller: PLC Application	✓	✓	✗	✓
Controller: Retain Variables	✓	✓	✗	✓
EtherCAT Devices: Network Topology	✗	✓	✗	✓
EtherCAT Devices: AKD / AKD2G Drive Firmware	✗‡	✓	✗	✓
EtherCAT Devices: AKD / AKD2G Drive Parameters	✗	✓	✗	✓

‡ Restore only

8.7.7.3 Data Transfer

- The 7-segment display shows chasing light animation while the backup or restore is occurring.



- The Backup and Restore functions have an all-or-nothing behavior.
 - AKD PDMM / PCMM: If there is no SD card inserted, not enough space on the card, or if files are missing, nothing is copied and the 7-segment display shows an error code.
 - PCMM2G: If there is no USB flash drive inserted, not enough space on the USB, or if files are missing, nothing is copied and the 7-segment display shows an error code.

- If files already exist on the SD card or USB flash drive (in the backup directory), they are deleted and replaced with the new backup configuration files.
 - The files on the controller are replaced with the SD card or USB flash drive files.

⚠ WARNING

Do not modify the files on the SD card or USB flash drive.
This could result in the restore function failing.

👉 TIP

If there are multiple backup configurations, you must use one SD card or USB flash drive per backup configuration.

8.7.7.4 B3 Button Backup**NOTE**

PCMM2G: Currently does not support controller backup using the B3 menu button.

One of the functions accessible from the B3 button is backing up the controller.

- The Backup function stores a copy of the data on the:
 - AKD PDMM or PCMM's SD card.
 - PCMM2G's USB flash drive.
- This function is shown in the 7-segment display as **bACUP**.



- Pressing B2 selects the function.
 - This function does not initiate automatically.
 - B2 must be pressed again to confirm the process.

The data that is backed up and copied to the SD card includes:

- PLC Application (including ECAT XML configuration, cam tables, etc.)
- AKD PDMM or PCMM configurations (auto-start and IP address).
- PLC application.
- "Retain Variables" (→ p. 707).

NOTE

Controller Log files and EtherCAT devices are not copied to the SD card.
They can be backed up using the "Backup tab" (→ p. 435) in the Web server.

8.7.7.5 B3 Button Restore**NOTE**

PCMM2G: Currently does not support controller restore using the B3 menu button.

One of the functions accessible from the B3 button is restoring the controller and AKD PDMM's drive.

- The Restore function restores and load files onto the controller from an SD card.
- This function is shown in the 7-segment display as **rEStorE**.



- Pressing B2 selects the function.
 - This function does not initiate automatically.
 - B2 must be pressed again to confirm the process.

- The 7-segment display flashes a **y**, prompting for confirmation.
 - Press B2 again confirms the function.
The data transfer begins.
 - If the function is not confirmed within 10 seconds the action is canceled.

The data restored from the SD card includes:

- AKD PDMM or PCMM configurations (auto-start and IP address).
- Network configuration.
- PLC Application (including ECAT XML configuration, cam tables, etc.)
- "Retain Variables" (→ p. 707).
- Shared Directory settings.
- "User Data tab" (→ p. 413).
- Web server and SSH user accounts configuration.

8.7.8 Backup and Restore tab

The controller can backup and restore EtherCAT devices on an EtherCAT network.

This feature:

- Is useful as a maintenance operation to replace any controller drives in an operational machine.
- Reduces the manual steps for saving/loading each drive's firmware and parameters into a few automated steps.

The Backup/Restore functionality is located in the controller's Web server and is accessible from a web browser.

See these topics for more information:

- "Using the KAS Web server" (→ p. 402)
- "Backup tab" (→ p. 435)
- "Restore tab" (→ p. 439)

KAS Application
Settings
Backup & Restore
Diagnostics
Help



Backup & Restore

Backup data is stored on the SD card. The following features are not accessible when a PLC application is running or Online Configuration Mode is active.

EtherCAT devices backup: Thu, 24 Oct 2019 18:57:44 UTC

Backup

Restore

Import/Export

Controller



Do you want to add the 1.2 GHz firmware to the backup (800MHz is already included)?

YES NO

Backup Controller

Backup Controller is used to replicate a PCMM or the controller portion of a PDMM. The elements that are backed up are the firmware, network configuration, retained variables, and PLC application.

Notes:

- * This function cannot be performed while an application is running.
- * Backup Controller takes several minutes to complete. Do not power off the controller once started.

EtherCAT Devices

Backup EtherCAT Devices

Backup EtherCAT Devices will save the network topology, the AKD and/or AKD2G drives' firmware, and the drives' parameters.

For EtherCAT devices backup operation, a matching AKD and/or AKD2G firmware package is required.

- * If a matching firmware package already exists on the controller, it will be used for future backups.
- * If a matching firmware package does not exist on the controller, you will be asked to provide it.

⁽¹⁾All firmware packages are available at Kollmorgen.com

See the "Controller Backup and Restore" (→ p. 387) in the KAS-IDE help.

8.7.8.1 EtherCAT Devices Backup

The Backup operation discovers all devices on the EtherCAT network and stores the topology information, drive firmware files, and parameters.

Controller	Local Storage
AKD PDMM or PCMM	SD Memory Card See "SD Card Support" (→ p. 387) for more information.
PCMM2G	Controller flash memory

8.7.8.1.1 Required Items

These items are required before starting a backup of the EtherCAT devices:

- The controller's firmware files package (you are prompted with the expected file).
 - The package is:
 - Included in the KAS software installation directory (\Program Files (x86)\Kollmorgen\Kollmorgen Automation Suite\Astrolabe\DrivesFW).
 - Available for download from the Kollmorgen [AKD® Series Servo Drives website](#).
 - AKD PDMM or PCMM require an SD memory card in the SD slot.
 - PCMM2G requires a USB flash drive connected to the USB port.

8.7.8.1.2 Device Connection and Configuration

All EtherCAT network devices must be:

- Connected to the controller.
- Configured as necessary for machine operation.

TIP

Verify the devices are in the order as expected.

The topology information is stored in the backup and is used to check for identical topology during a restore function.

The device order is not important. **Example:** An AKD can be anywhere in the EtherCAT topology but, for restore to occur, the devices must be in the same order as when backed up.

- A PLC application downloaded to the controller, containing the EtherCAT device map.

NOTE

The PLC application cannot be running and the IDE must not be in "Online Configuration Mode" (→ p. 255).

Stop the PLC application or disable Online Configuration Mode before a Backup or Restore.

8.7.8.1.3 Modular EtherCAT

This procedure should be followed to backup EtherCAT devices when the modular EtherCAT feature is used to remove devices to create a machine variant.

See "Modular EtherCAT Concept" (→ p. 617) for more information.

1. Run the KAS application which sets up the correct EtherCAT topology for the machine variant.
2. Stop the KAS application.

IMPORTANT

Do not power cycle or reboot the controller between Steps 2 and 3.

3. Backup the EtherCAT devices.
See "Backup Procedure" (→ p. 391) for more information.

8.7.8.1.4 Backup Procedure

1. From the web server home page, click the **Backup & Restore** tab.
2. On the **Backup** tab, click the Backup EtherCAT Devices button.

The web server will ask you to choose one or more firmware package files and suggest the filename that matches the firmware version on your drives.

Selecting the firmware package files is a one-time event.

The controller remembers the selection for future backups.

NOTE
 AKD series drives have a firmware package file specific to their firmware version.
 AKD2G has a different firmware package file specific to its firmware version.

3. Press the Continue Backup EtherCAT Devices button. It will take a couple of minutes or longer, depending on the number of AKD and/or AKD2Gs in the system.

When the backup is complete, the web server will indicate whether the backup was successful.

TIP
 After the backup is complete, it is a good idea to export the backup to an off-site location for safe keeping. See "Controller Import / Export Backup from Web server" (→ p. 395) for more information.

8.7.8.2 EtherCAT Devices Restore

The Restore operation discovers the devices on the EtherCAT network and compares the physical topology information to the topology information stored in the backup.

- A Restore detects the replaced controller devices and restores them.
- Advanced users can manually select the specific controller devices and restore them.
- The backup files containing the topology information, drive firmware file, and drive parameters are retrieved from the controller's local storage.

Controller	Local Storage
AKD PDMM or PCMM	SD Memory Card See "SD Card Support" (→ p. 387) for more information.
PCMM2G	USB flash drive

8.7.8.2.1.1 Procedure

ⓘ IMPORTANT

The application starts immediately after the Restore operation is complete if the Autostart option is enabled on the controller.

Be sure to Restore all of the replaced devices and the EtherCAT device order is correct.

Disable the Autostart option before commanding the Restore operation if you want to check the devices before starting the application.

NOTE

The EtherCAT Devices Backup and Restore feature may be used in EtherCAT networks with third-party devices but only the Kollmorgen controller can be backed up and restored.

Specific configurations applied to third-party devices with non-Kollmorgen tools have to be reapplied when the third-party device is replaced.

- From the web server home page, click the **Backup & Restore** tab.
- Under the **Restore** tab, choose to either:
Restore the replaced EtherCAT controller devices.
Manually select the devices with the Advanced view.
 - To restore the replaced controller devices, click the **Restore EtherCAT Devices** button.
When the restore is complete, the web server indicates whether it was successful.
 - To select the controller devices and manually restore:
 - Click the **Advanced** link.
 - Select the devices to restore.
The controller identifies the replaced drives and pre-selects them.
 - Click **Restore selected devices**.

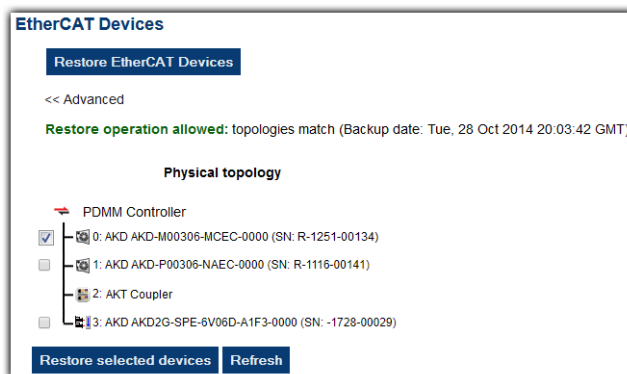

When the restore is complete, the Web server indicates whether it was successful.

8.7.8.3 AKD or AKD2G Backup / Restore Compatibility

The replacement AKD or AKD2G must have the same model number as the device that was originally stored in the backup.

- All AKD drives **must have** the same firmware version for the Backup and Restore to work.
- The Restore operation compares the model numbers between the backup and the replacement AKD.
 - Restore is not allowed if they are not compatible.

TIP

The **AKD-Pxxxxx-NB** and **AKD-Pxxxxx-NC** models are functionally compatible with, and may be replaced with, **AKD-Pxxxxx-ND** devices provided the backup contains AKD firmware version v01-22-00-000 and later.

		Restore		
		NB	NC	ND
Backup	NB	✓	✓	✓
	NC	✓	✓	✓
	ND	✗	✗	✓

- To check the model number on your AKD or AKD2G, see the sticker on the side of the drive.
- To check compatibility between your replacement drive and the backup, replace the AKD or AKD2G on the EtherCAT network and press the Scan network button.
 - The Web server displays the physical topology and allows you to restore the selected drives if the backup and replacement drives are compatible.



Backup & Restore

Note that most of the following features are not available when PLC application is running or online config mode is active

EtherCAT devices backup: Mon, 29 Oct 2012 08:40:08 GMT

Backup
Restore
Import/Export

Controller



Restore Controller

Restore Controller is used to replicate a PCMM or the controller portion of a PDMM. The elements that are restored are the firmware, network configuration, retained variables, and PLC application.

Notes:

- * *Restore Controller* takes several minutes to complete. Do not power off the controller once started.
- * The controller is rebooted after a **Restore**.

EtherCAT Devices

Restore EtherCAT Devices

<< Advanced

Restore operation allowed: topologies match (Backup date: Tue, 07 Jul 2015 18:12:48 GMT)

Physical topology

- Controller
 - 0: AKD AKD-M00306-M1EC-D000 (SN: R-1432-00169)
 - 1: AKD AKD-P00306-NAEC-0000 (SN: R-0934-00008)
 - 2: Beckhoff Automation GmbH device 0x4602C22

Restore selected devices
Refresh

- The Web server displays the backup and physical topology and indicates the non-compatible drives if the backup and replacement drive are not compatible.

TIP

The serial number (SN) is displayed in the Physical topology Web server view and on the sticker affixed to the AKD or AKD2G.

Use the serial number to match the actual hardware with its representation on the Web server.

8.7.8.4 Controller Import / Export Backup from Web server

8.7.8.4.1 Controller Backup Import / Export

Controller backup data can be saved to or written from a removable storage devices (SD card or USB flash drive).

- This functionality is available when a controller backup file exists on the device's SD card or USB flash drive.
 - See the "Backup tab" (→ p. 435) for more information.
- During the import process, this function replaces an existing backup file without further prompting.
 - If the process is interrupted or fails, it does **not** overwrite the backup file.

8.7.8.4.2 EtherCAT Devices Backup Import / Export

A network backup may be exported and imported.

- The export procedure saves a backup file to the computer running the web browser.
- The import procedure transfers a backup file onto the controller to be used later for restoring a previous configuration.



Backup & Restore

Backup data is stored on the USB flash drive. The following features are not accessible when a PLC application is running or Online Configuration Mode is active.

No EtherCAT devices backup on the controller

Backup Restore **Import/Export**

Controller

Import backup: **Choose File** No file chosen
 Replace Controller Backup

EtherCAT Devices

Import backup: **Choose File** No file chosen
 Replace EtherCAT Backup

Export Controller Backup:
Export EtherCAT Backup:
 Controller or EtherCAT devices backup file is saved to this computer.
 Note: The Export Controller/EtherCAT button is only displayed when the corresponding backup is available.
 * The backup filename of the exported file is:
 'KAS-pcmm2g-controller-backup.zip' for Controller backup.
 'KAS-network-backup.tgz' for EtherCAT devices backup.

Import Controller Backup:
Import EtherCAT Backup:
 Controller Backup (.zip) or EtherCAT Devices Backup file (.tgz file) is transferred from this computer to the controller. This backup file is used when you need to restore a previous configuration.
 Note: The Replace Backup button is disabled until a backup file has been selected.

8.7.8.4.3 Export Procedure

NOTE

The Export button is only visible if a controller backup is available.

1. Click the **Export EtherCAT Backup** button. The browser starts transferring a backup file. Depending upon the browser being used, this may involve a prompt confirming receiving the file.
2. You may move the file to a different directory once the file is saved. The file may be renamed to help identify the backup file with the machine.

8.7.8.4.4 Import Procedure

1. Click the **Choose File** button and select the backup file to import. This backup file is used to replace the current backup on the controller.
2. Click the **Replace EtherCAT Backup** button. This creates a backup on the controller with the data stored in the specified backup file. Any previously existing backup is replaced. If the import fails, the previous backup is not replaced.

The Replace Backup button is disabled until a backup file has been selected.

On some browsers, the **Browse** button may be labeled **Choose File**.

8.7.8.5 EtherCAT Devices Backup / Restore Limitations

- Only AKD and AKD2G drives are supported for backup/restore.
 - Kollmorgen S300 and S700 drives are not supported by backup/restore.
- AKD PDMM or PCMM system backup or restore is a two-step process:
 1. Backup or Restore the controller.
 2. Backup or Restore the drives (including the AKD drive inside the AKD PDMM).
- Only a single backup is supported in the controller at one time.

NOTE

To keep multiple backup configurations, perform the backup and then export it to a local PC. When ready to restore, import the specific backup file to the controller and then perform the restore.

ⓘ IMPORTANT

An import overwrites any backup existing in the controller's removable storage device.

8.7.8.5.1 Backup Conditions

These conditions must be met before starting an EtherCAT device backup:

1. The KAS application should be run and then stopped.
2. Do not power cycle or reboot the controller after stopping the KAS application.

The "EtherCAT Devices Backup" (→ p. 391) and "EtherCAT Devices Restore" (→ p. 392) functions are not permitted:

- While a PLC application is running.
- When the KAS-IDE is in "Online Configuration Mode" (→ p. 255).
 - Stop the PLC application or disable Online Configuration Mode before a Backup or Restore.

All drives on the EtherCAT network must have the same firmware version.

- The AKD firmware version must be 01-06-00-003 or higher.
- AKD and AKD2G firmware packages are available for all production releases.

8.7.8.6 EtherCAT Devices Backup / Restore Troubleshooting

The web server displays an error message if there is a failure of an EtherCAT device backup or restore.

- The message describes the cause of the failure and a possible remedy.
- Note any error messages; they are helpful with remedying the problem.
- These are some common error messages and remedies.
- The message box format may appear differently depending on the web browser, but the message content is the same.

During AKD/AKD2G backup, EtherCAT fails to reach pre-op mode:

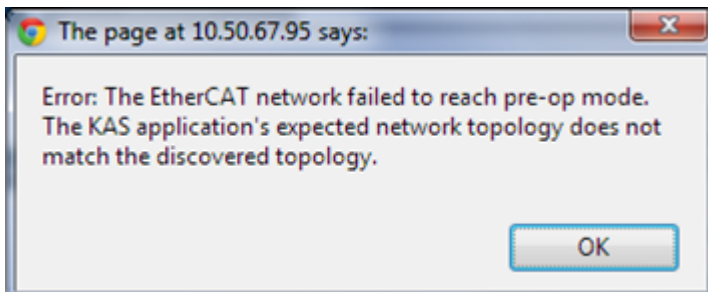

1. Using the IDE, open the EtherCAT view and scan the network.
2. Compare the nodes, their order, and types to the topology in your application.
3. After you identify the differences, either:
 - Modify the application's devices to match the physical network.
 - Correct the physical network by adding/moving/removing nodes.

During AKD/AKD2G backup, at least one drive has an unsupported firmware error for backup:

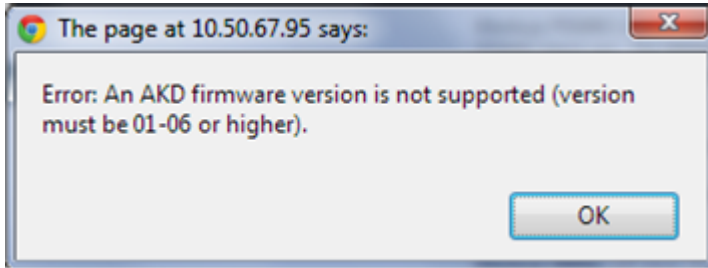

1. Using the IDE, open the EtherCAT view.
2. Upgrade all of the AKDs drive firmware to at least version 01-06.

During AKD/AKD2G restore, the backup file is corrupt:

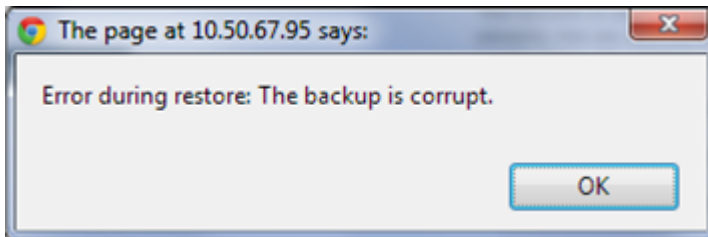

Before restoring the AKD or AKD2G, the backup file must be valid.

- To correct a bad backup file on a controller, import a known good backup file from another source (e.g., local hard drive, network drive, USB flash drive, etc.)
- If a valid backup file is not available, you must manually configure the replacement drives by downloading firmware and changing the drive's parameters using the AKD/AKD2G views in the KAS-IDE.

Not able to restore AKD or AKD2Gs successfully.

The error message describes at which step the restore failed (e.g., failing to restore parameters).

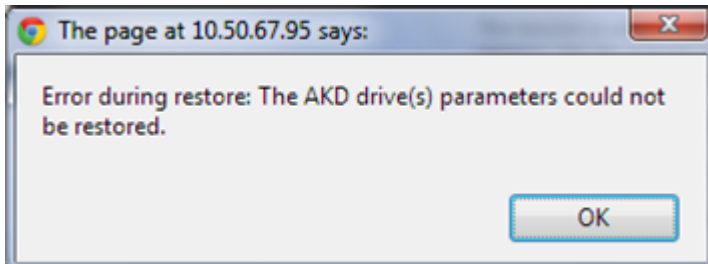

1. If an AKD or AKD2G restore fails and you have already verified the controller has a valid backup and the network topology is correct, then retry the Restore.
2. If you still cannot restore successfully after two or three attempts, check the network cables and try a different replacement drive(s).
This test isolates the problem to the specific drives or the controller problem.
3. If you still cannot restore a replacement AKD or AKD2G, then you must manually configure the replacement AKD or AKD2G by downloading firmware and modifying the drive's parameters using the drive views in the KAS-IDE.

8.8 Controller Onboard I/O

The procedure to define the local I/Os of the controller is similar to the one for I/O slices.

- The Onboard digital I/O update rate for:
 - PCMM2G matches the EtherCAT update rate.
 - AKD PDMM and PCMM is limited to a 1kHz update rate.

EtherCAT Update Rate	Onboard Digital I/O Update Rate	
	PCMM2G	AKD PDMM and PCMM
500Hz	500Hz	500Hz
1kHz	1kHz	1kHz
2kHz	2kHz	1kHz
4kHz	4kHz	1kHz

See "Map Input and Output to Variables" (→ p. 314).

8.9 Using SSH

The Kollmorgen controllers can be accessed using [SSH](#).

- SSH is used to perform maintenance operations that are not available through the web interface.
- Kollmorgen Application Engineers may need to use SSH to access the controller to help resolve customer issues.

8.9.1 Login

- AKD PDMM and PCMM allows login using the **root** user.
- PCMM2G only allows access to the **admin** user.

Because the admin user is in the [sudo](#) group, the user can use root privileges to perform maintenance using the sudo command.

- Internally, the controller uses a **kas** user account.
 - It is recommended to not use this account because files in the **kas** user directory are critical to the proper functioning of the controller.

ⓘ IMPORTANT

To ensure security, it is critical that the login password be changed from the default value. See "Change Controller's Password using SSH" (→ p. 401) for more information.

See Also

- "SSH Login to a Controller" (→ p. 400)
- "Restore Controller Default Password" (→ p. 402)

8.9.2 SSH Login to a Controller

An SSH client is required to log in to a controller using [SSH](#).

NOTE

The first time you log into the controller, you may be prompted (depending on the client) whether you trust the device (controller).

The admin/root password and the webserver password are separate. One does not affect the other.

8.9.2.1 Login to AKD PDMM and PCMM

1. Configure the SSH client using these settings:

Setting	Value
Host Name or IP Address	IP Address of the controller.
Connection Type	SSH
Port	22

2. At the login prompt, enter the user name and password.
 - Default User Name: `root`.
 - Default Password: `administrator`.

8.9.2.2 Login to PCMM2G

1. Configure the SSH client using these settings:

Setting	Value
Host Name or IP Address	IP Address of the controller.
Connection Type	SSH
Port	22

2. At the login prompt, enter the user name and password. The admin password is unit-specific. It is assigned based on the serial number of the unit.
 - Default User Name: `admin`.
 - Default Password: `pcmm2g` + the last three digits of the controller serial number.
 - Example: If the controller serial number is KL2023180027, default password is `pcmm2g027`.

NOTE

The controller serial number can be found from the "Home tab" (→ p. 404) or by checking the label printed on the unit.

8.9.2.2.1 List of Common SSH Clients

Kollmorgen does not recommend any particular program.

These are some common SSH clients:

- [PuTTY](#)
- [TeraTerm](#)

ⓘ IMPORTANT

To ensure security, it is critical that the login password be changed from the default value. See "Change Controller's Password using SSH" (→ p. 401) for more information.

8.9.3 Change Controller's Password using SSH

This method is used to change the controller's root password using [SSH](#).

1. Log on through SSH.
2. At the prompt, type `passwd` and press <Enter>.
3. If prompted, enter the current password.
4. In the next two prompts, enter the new password.

NOTE

AKD PDMM and PCMM use the root account.
PCMM2G uses the admin account.

8.9.3.1 AKD PDMM and PCMM: Change Password

```
# passwd
changing password for root
New password:
Retype new password:
#
```

8.9.3.2 PCMM2G: Change Password

```
kas-pcmm2g:~$ passwd
Changing password for admin.
Current password:
New password:
Retype new password:
passwd: password updated successfully
```

8.9.4 Restore Controller Default Password

This procedure is used to restore the controller default password.

8.9.4.1 Restore to Factory Settings

⚠ WARNING

Performing a factory reset of the controller should be considered very carefully.

The reset erases everything: User data files, the application, the controller IP address, any retain variables, passwords, shared directory settings, and all log files.

This restore is applicable to all controllers.

See "Reset the Controller to Factory Settings" (→ p. 385) for more information.

8.9.4.2 Restore AKD PDMM and PCMM

8.9.4.2.1 Restore using SSH

📌 IMPORTANT

This section only applies to AKD PDMM and PCMM.

👉 TIP

This restore method is recommended if it is possible.

- Restore the `/mount/flash/etc` directory using these shell commands:

This method should be used if logging in via SSH is possible.

```
# rm -r /mount/flash/etc
# shutdown
```

Result: The controller loads the default settings upon restarting.

8.9.4.3 Restore PCMM2G

The PCMM2G password is reset to the factory default using the "Reset the Controller to Factory Settings" (→ p. 385) procedure.

📌 IMPORTANT

To ensure security, it is critical that the login password be changed from the default value. See "Change Controller's Password using SSH" (→ p. 401) for more information.

8.9.5 Using the KAS Web server

Kollmorgen Automation Suite™ comes with a Web server used to perform these operations:

- Read information about the controller (i.e., model, runtime or firmware version, KAS version).
- Interact with your application (Start and Stop your KAS application).
- View real and simulated axes.
- Connect to a shared directory.
- See all the log messages.
- Upgrade the controller firmware.
- Change the IP address.
- View system diagnostics including storage space, memory and CPU temperature.
- Reset the controller to factory settings.
- Backup/Restore the controller.
- Backup/Restore EtherCAT devices.

8.9.5.1 Access the Web server

The Web server is accessed either with:

- "Web Browser Access" (→ p. 403)
- "Controller B3 Access" (→ p. 403)

8.9.5.1.1 Web Browser Access

1. Open a web browser and enter the controller's IP address.
2. From the controller node in the Project tree in the KAS-IDE, double-click the controller node.
3. Click **Access Webserver** from the right-mouse menu.

8.9.5.1.2 Controller B3 Access

Use this procedure if you do not know the IP address assigned to the controller.

1. Press B3 once.



The 7-segment display flashes the letters I and P.

2. Press B2 to select the IP option.



The 7-segment display shows the IP address.



8.9.5.1.3 Links

The controller shows these links:

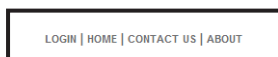

- Login
 - Opens the Kollmorgen controller login dialog.
- "Home tab" (→ p. 404)
- Contact Us
 - Shows Kollmorgen Support contact information.
- About
 - Shows the Kollmorgen Automation Suite copyright information.

8.9.5.1.4 Tabs

The controller shows these tabs:

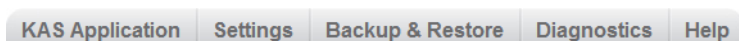

- "KAS Application tab" (→ p. 408)
- "Settings tab" (→ p. 415)

- "Backup and Restore tab" (→ p. 390)
- "Diagnostic tab" (→ p. 440)
- Help tab - This tab opens the WebHelp for the controller.

TIP

Browser Requirements: We recommend using [Microsoft Edge](#), [Mozilla Firefox](#), or [Google Chrome](#) for accessing the web server.

8.9.6 Home tab

To access the KAS web server home page, enter the controller's IP address.

Kollmorgen Automation Suite™	
Manufacturer	Kollmorgen
CPU Speed	1.5 GHz
CPU Cores	4
Model Number	PCMM2G-C4-16-000-00-0000
Serial Number	1
Hardware Revision	1
TCP/IP Mac Address	00:23:1b:01:10:e6
EtherCAT Mac Address	e4:5f:01:6e:db:dd

KOLLMORGEN
A REGAL REYNOLD BRAND

Kollmorgen
203A West Rock Road
Radford, VA 24141 USA

© Copyright 2023 Kollmorgen. All rights reserved.

This page provides an overview of the device including:

- Manufacturer
- CPU Speed
- CPU Cores
- Model Number
 - See "Controllers" (→ p. 685) for more information.
- Serial Number

- Hardware Revision
- TCP/IP MAC Address — a unique value associated with the TCP/IP network adapter that uniquely identifies the adapter on a LAN.
- EtherCAT MAC Address — a unique value associated with the EtherCAT network adapter that uniquely identifies the adapter on an EtherCAT network.

NOTE

Unless otherwise noted, any reference to AKD PDMM or PCMM refers to both the 800MHz and the single- and dual-core 1.2GHz variants.

8.9.6.1 Security

Some parts of the web server are locked to protect critical operations from unauthorized users.

Log into the web server to enable access to the locked functions.

See "User Authentication" (→ p. 406) for more information.

NOTE

Functions are not locked if you access the web server through the IDE.
This automatically grants administrator access.

These functions are locked:

- "Backup and Restore" (→ p. 405)
- "Diagnostics tab" (→ p. 405)
- "KAS Application tab" (→ p. 405)
- "Settings tab" (→ p. 405)

8.9.6.1.1 Backup and Restore

- Backup
- Restore
- Export Backup
- Choose File and Replace Backup

8.9.6.1.2 Diagnostics tab

- Reboot the controller.
- Clear errors and alarms.
- Clear a crash dump.

8.9.6.1.3 KAS Application tab

- Start, stop, or cold-start an application.
- Clear user data.
- Clear all errors.
- Configure auto-start.
- Apply or clear shared directory settings.

8.9.6.1.4 Settings tab

- Firmware upgrade - choose File and Upgrade.
- Reboot the controller or device.
- Reset to factory settings.
- SD card format.
- Change password.
- Change the network settings (IP address).

8.9.6.1.5.1 PCMM2G Only

- Configure the NTP.
- Update the time zone.
- Format a USB flash drive.

8.9.6.1.6 Timeout after Inactivity

To prevent misuse, if the webserver has been idle (no keyboard activity or mouse clicks) for 20 minutes, the user account is automatically logged out.

A dialog box opens to alert you that the session has timed out.

NOTE

The idle logout only occurs if you've logged into the webserver with a web browser. Logging in through the KAS-IDE will never time out.

8.9.6.2 User Authentication

8.9.6.2.1 Login In

Login to the Web server is required to prevent unauthorized access or changes.

This is accessed from the **LOGIN** link at the top of all Web server pages.

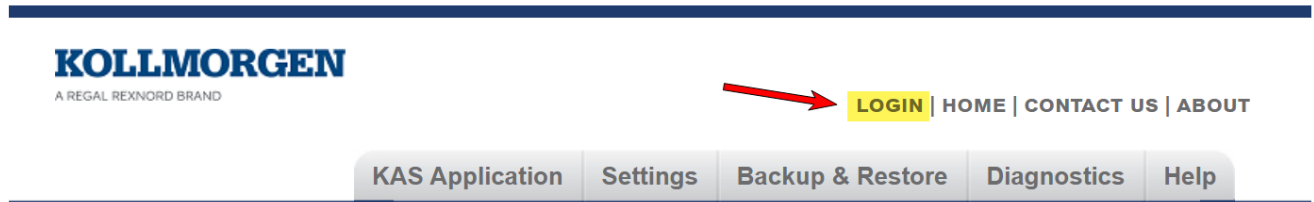

Kollmorgen Automation Suite™

Manufacturer	Kollmorgen
CPU Speed	1.5 GHz
CPU Cores	4
Model Number	PCMM2G-C4-16-000-00-0000
Serial Number	1
Hardware Revision	1
TCP/IP Mac Address	00:23:1b:01:10:e6
EtherCAT Mac Address	e4:5f:01:6e:db:dd

Click the **LOGIN** link to open the **Login** dialog.

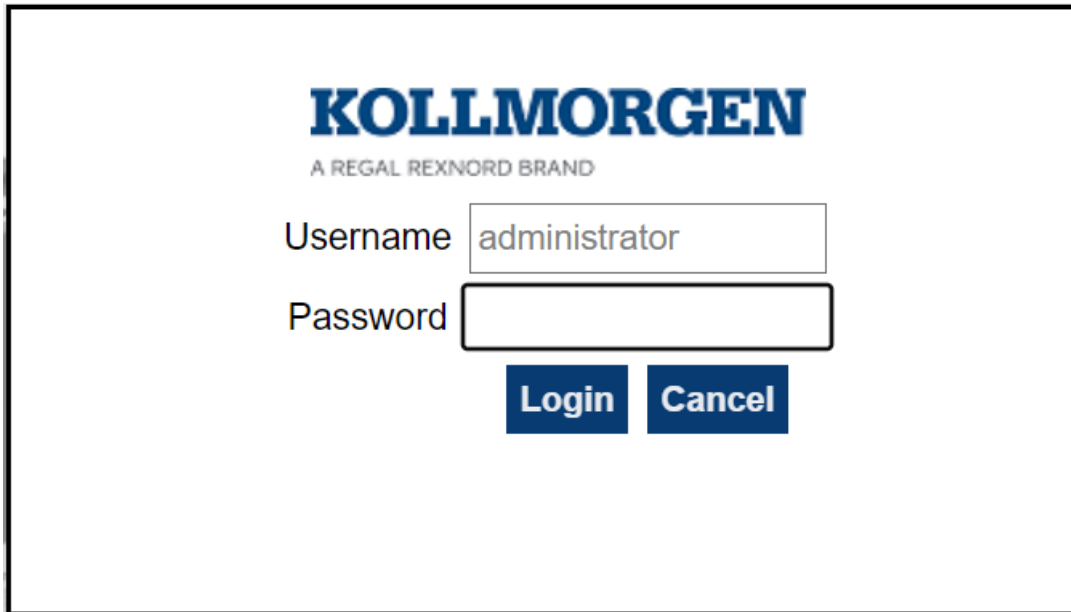

Figure 9-1: Login dialog

Enter the password to log in.

The factory default password is `administrator`.

This can be changed after logging in.

NOTE

There is only one user Administrator; **administrator** is the default user name.

- Re-enter the password each time you log in.
- The entered password is **not** stored in the **Login** dialog.
- Accessing the Web server from the IDE automatically logs you in as Administrator.

When successfully logged in, the user name appears in the top-right corner of all Web server screens.

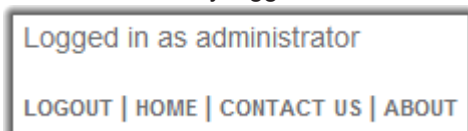

8.9.6.2.2 Logging Out

After successfully logging in, the menu in the top right corner of the web server contains a link to **LOGOUT**.

Click this link to immediately log out of the Web server.

A confirmation message appears.

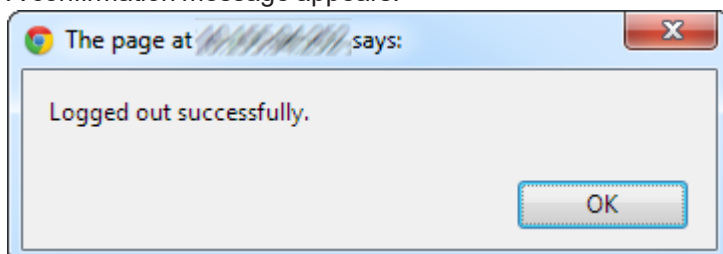

8.9.6.2.3 Changing the Password

The user password is managed from the **User Account** tab of the **Settings** tab.

See "Change the Web server's User Account Password" (→ p. 433) for more information.

8.9.7 KAS Application tab

This tab is used to:

- Display general information about your project that is currently loaded on the controller.
- Start and stop the motion.
- Display the Axes run by the controller from the "Axis tab" (→ p. 408) tab.
- Manage log messages from the "Log Configuration tab" (→ p. 409) and "Log Data tab" (→ p. 410) tabs.
- Display User Data present on the controller from the "User Data tab" (→ p. 413) tab.
- Connect to a remote computer from the "Shared Directory tab" (→ p. 414) tab.

Item	Description
Version of KAS App	<p>This label provides information about the name and version number of the application that is in the controller.</p> <ul style="list-style-type: none"> • The format is <project_name>:<version>. • The application's source code may be downloaded to the local computer if it is present on the controller. <ul style="list-style-type: none"> • Click the download button () • This icon is found by the name and version information and is only present when source code is available.
Status of KAS App	The state of the application, either: Started or Stopped .
Start	<p>Default mode (warm start) where the Retain Variables are loaded at the application startup.</p> <p>They are Not re-initialized; whereas other variables are started with their initial values.</p> <p>See "Retain Variables" (→ p. 707) for more information.</p>
Cold Start	<p>Use retain variables with their default values.</p> <p>Such starts occurs from time to time but are few.</p>
Stop	Stop the application.
Auto-start	<p>Select this option to automatically start the KAS application when the controller is powered up.</p> <ul style="list-style-type: none"> • The application starts using retained variables (a "warm start") after the controller has booted up. • To change this setting, click the Auto-start checkbox to either activate or deactivate this option and click the Apply button. <ul style="list-style-type: none"> • The control uses the new setting at the next power-up. • This option is recommended when the system is in production.
Clear all errors	Click this button to clear the error log for all axes.

8.9.7.1 Axis tab

You can view a visual representation of the motors from the **Axis** tab.

The axis wheels are visible after your application is started.

These items can be monitored from the display:

- Real and Simulated axes.
- Actual position with solid line and actual position value.
- Command position with the dotted line and (command position value) in parentheses.
- Axis State: Powered-off , Powered-On, or Error as well as Simulated Powered Off and ON.

- Identify the axes from the label, as defined by the axis name in your application.
- Axis status or positions snapshot.



Figure 9-2: Axis examples

Information that is available by clicking on the axis																																																											
Title	Image (PN axis)	Image (PLCopen axis)	Image (digitizing axis)																																																								
<p>AXIS1</p> <p>Axis status snapshot</p> <table border="1"> <tr><td>Initialised</td><td>true</td></tr> <tr><td>Power ON</td><td>false</td></tr> <tr><td>Enable</td><td>true</td></tr> <tr><td>Found</td><td>true</td></tr> <tr><td>Configured</td><td>true</td></tr> <tr><td>Running</td><td>false</td></tr> <tr><td>Error</td><td>false</td></tr> <tr><td>Simulated</td><td>false</td></tr> <tr><td>Connected</td><td>false</td></tr> <tr><td>Warning</td><td>false</td></tr> <tr><td>Stopping</td><td>false</td></tr> <tr><td>Stopped</td><td>false</td></tr> </table>	Initialised	true	Power ON	false	Enable	true	Found	true	Configured	true	Running	false	Error	false	Simulated	false	Connected	false	Warning	false	Stopping	false	Stopped	false	<p>AXIS1</p> <p>Axis positions snapshot</p> <table border="1"> <tr><td>Actual</td><td>174.220505</td></tr> <tr><td>Current</td><td>0.000000</td></tr> <tr><td>Feedback</td><td>174.220505</td></tr> <tr><td>Generator</td><td>0.000000</td></tr> <tr><td>Pipe offset</td><td>0.000000</td></tr> <tr><td>Pipe</td><td>0.000000</td></tr> <tr><td>Power ON Delta</td><td>0.000000</td></tr> <tr><td>Offset</td><td>0.000000</td></tr> <tr><td>Reference</td><td>0.000000</td></tr> <tr><td>Zero offset</td><td>0.000000</td></tr> </table> <p>See "Axis Pipe Block" (→ p. 733).</p>	Actual	174.220505	Current	0.000000	Feedback	174.220505	Generator	0.000000	Pipe offset	0.000000	Pipe	0.000000	Power ON Delta	0.000000	Offset	0.000000	Reference	0.000000	Zero offset	0.000000	<p>PLCOpenAxis2</p> <p>Axis positions snapshot</p> <table border="1"> <tr><td>Actual</td><td>3141.856728</td></tr> <tr><td>Command</td><td>3141.856728</td></tr> <tr><td>Normal</td><td>3141.856728</td></tr> <tr><td>Phase</td><td>0.000000</td></tr> <tr><td>Super imposed</td><td>0.000000</td></tr> </table> <p>See "Axis Parameters" (→ p. 749).</p>	Actual	3141.856728	Command	3141.856728	Normal	3141.856728	Phase	0.000000	Super imposed	0.000000	<p>Axis3</p> <p>Axis positions snapshot</p> <table border="1"> <tr><td>Actual</td><td>0.000000</td></tr> </table>	Actual	0.000000
Initialised	true																																																										
Power ON	false																																																										
Enable	true																																																										
Found	true																																																										
Configured	true																																																										
Running	false																																																										
Error	false																																																										
Simulated	false																																																										
Connected	false																																																										
Warning	false																																																										
Stopping	false																																																										
Stopped	false																																																										
Actual	174.220505																																																										
Current	0.000000																																																										
Feedback	174.220505																																																										
Generator	0.000000																																																										
Pipe offset	0.000000																																																										
Pipe	0.000000																																																										
Power ON Delta	0.000000																																																										
Offset	0.000000																																																										
Reference	0.000000																																																										
Zero offset	0.000000																																																										
Actual	3141.856728																																																										
Command	3141.856728																																																										
Normal	3141.856728																																																										
Phase	0.000000																																																										
Super imposed	0.000000																																																										
Actual	0.000000																																																										

Additionally, if an axis is in error, the error can be cleared by clicking the text below the axis title.

8.9.7.2 Log Configuration tab

You can configure the log to filter the messages that are displayed.

Each source can be set with its own level.

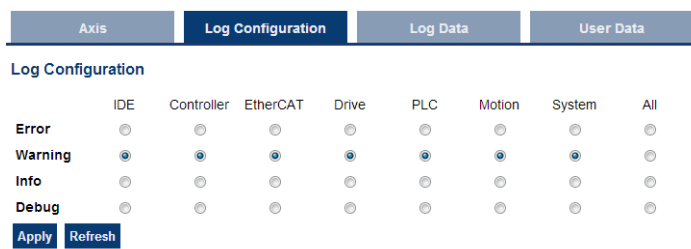

Each message has one of these levels, with importance in descending order:

Error > Warning > Info > Debug

TIP

How to Choose the Appropriate Level?

When a level is set for a source, only messages with the same or higher importance are recorded.

Example: If a source is set to WARNING, then all messages with levels WARNING, ERROR and CRITICAL are recorded (DEBUG and INFO messages are discarded).

DEBUG is the most verbose and ERROR is the least verbose level.

Filtering is quicker with less verbose levels because of the number of messages.

NOTE





Critical messages are always recorded.

Therefore, the Critical level is not visible.

8.9.7.2.1 Source

Source	Apply to...
Controller	For the KAS Runtime items: Drivers, IOEngine, SinopEngine, etc.
Drive	Messages from Kollmorgen drives.
EtherCAT	For all kinds of EtherCAT items: Motion bus, I/Os
IDE	Win32 applications: <ul style="list-style-type: none"> • KAS-IDE • KAS Runtime Server (i.e., the KAS Runtime Front-end)
Motion	Messages coming from the Motion engines: <ul style="list-style-type: none"> • Pipe Network • PLCopen • VM
PLC	For application engineers to create a custom log within the PLC programs. See "Printf" (→ p. 235) for more information.
System	For common API and libraries. Includes messages issued from the operating system.

8.9.7.2.2 Level

Level	Icon	Description
CRITICAL		<ul style="list-style-type: none"> • Application crashes or becomes unstable. • Data is corrupted. • The application behavior can be unpredictable.
DEBUG		<ul style="list-style-type: none"> • Any information logged for development purpose. • This log can be safely ignored.
ERROR		The application does not behave as expected but the processes remain stable.
INFO		<ul style="list-style-type: none"> • Information status of the current process. • This log can be safely ignored.
WARNING		<ul style="list-style-type: none"> • System is stable but the KAS-IDE warns that an unexpected event can occur. • This log can be safely ignored.

8.9.7.3 Log Data tab

KAS log files may be viewed from the Log Data tab.

These messages can help describe the current state of the system and to help identify any operation errors encountered when developing your system.

Log Files

Figure 9-3: Example of Log Files from a Kollmorgen Controller's Webservice

Click a listed log file to open it in a web browser.

- Click the green download icon next to the log entry to download the log file.
- The default name is the same as the file's name.
- If a file no longer exists, the message `/logfiles/<selected file name> not found.` appears.
 - Refresh the browser window and try again.

Figure 9-4: Example of a log file's content in a browser.

NOTE

Controller log data is collected and updated every 15 seconds.
 A new log file is created when the current file is full.
 You may need to wait for up to 15 seconds for a log to show up in the list.

8.9.7.3.1.1 AKD PDMM and PCMM

The AKD PDMM and PCMM log files both have the same file naming scheme: `pdmm_log_XXXXXXXXXX`.

8.9.7.3.2.2 PCMM2G Only

- The file `error_alarm_history.log` contains a history of errors and alarms.
- Files whose names begin with an underscore are internal.
 - They may be requested by support engineers during troubleshooting.

8.9.7.3.3 Log Message Content

Log files contain one message per line, formatted as a CSV file.

Every log message contains this information:

Field	Description
Time	Time when the log was recorded with the format: DD-MMMM-YY hh:mm:ss (millisecond)
Source	Identifies a software or hardware component issuing the messages. Each source is configured with a specific Level. See "Log Messages Settings" (→ p. 104).
Level	Each message has one of these levels with importance in ascending order: DEBUG > INFO > WARNING > ERROR > CRITICAL. See "Log Messages Settings" (→ p. 104).
Message	Text of the message issued from the source.
Origin	The source code line where the message originated.

🔗 TIP

Log messages are an important source of information when you are troubleshooting your project.
 When reporting an issue to Kollmorgen Support, copy/paste the logs in the report.

8.9.7.3.4 Controller Log Files

- PCMM or AKD PDMM generated logs are stored in flash memory at `/mount/flash/log`.
- PCMM2G generated logs are stored in flash memory at `/home/kas/kas/log`.

Files are stored in a rotating pool consisting of a maximum of 10 files.

- The files have a maximum size of 200kb each.
- The most amount of space the log files will consume is 2MB.
- When a files is created after the tenth file, the earliest file is deleted to make room for the new file.

The controller-generated log levels can be controlled from the KAS-IDE and Web server.

KAS-IDE-generated log levels can be filtered in the configuration window in the **Logs and Information** tab.

8.9.7.3.5.1 Log File Naming Convention

Logs have this naming convention: `pdmm_log_n`.

Where:

- n is a value ranging from 0000000000 to 4294967295.
- This is the maximum value a 32-bit location can store.

Example

- When the files are first created they are named:
 - pdmm_log_0000000000
 - pdmm_log_0000000001
 - pdmm_log_0000000002, etc.
- The file that is created after pdmm_log_4294967295 is pdmm_log_0000000000.
 - The naming is reset and continues.

8.9.7.3.6.2 Error and Alarm History File (PCMM2G only)

The PCMM2G stores a file named `error_alarm_history.log` at `/home/kas/kas/log`.

This file stores a history of "Controller Error and Alarm Descriptions" (→ p. 668) that have occurred on the controller.

8.9.7.4 User Data tab

This tab lists any user-generated files or folders found in the Kollmorgen controller's flash memory.

- Click a folder to view the folders contents.
- Click the green download icon to immediately download the designated file.



[LOGIN](#) | [HOME](#) | [CONTACT US](#) | [ABOUT](#)

KAS Application

Settings

Backup & Restore

Diagnostics

Help



KAS Application

Version of KAS app *No Application*

Status of KAS app *stopped*

Start/Stop

Options Auto-start

Clear all axis errors

Axis

Log Configuration

Log Data

User Data

Shared Directory

User Data

The **Clear User Data** button erases all of the files in the user data folder.

8.9.7.5 Shared Directory tab

This tab is used to connect to and mount a shared directory on a remote computer (Window® 7 or later and non-Windows).

This allows a program to read and parse instructions for motion.

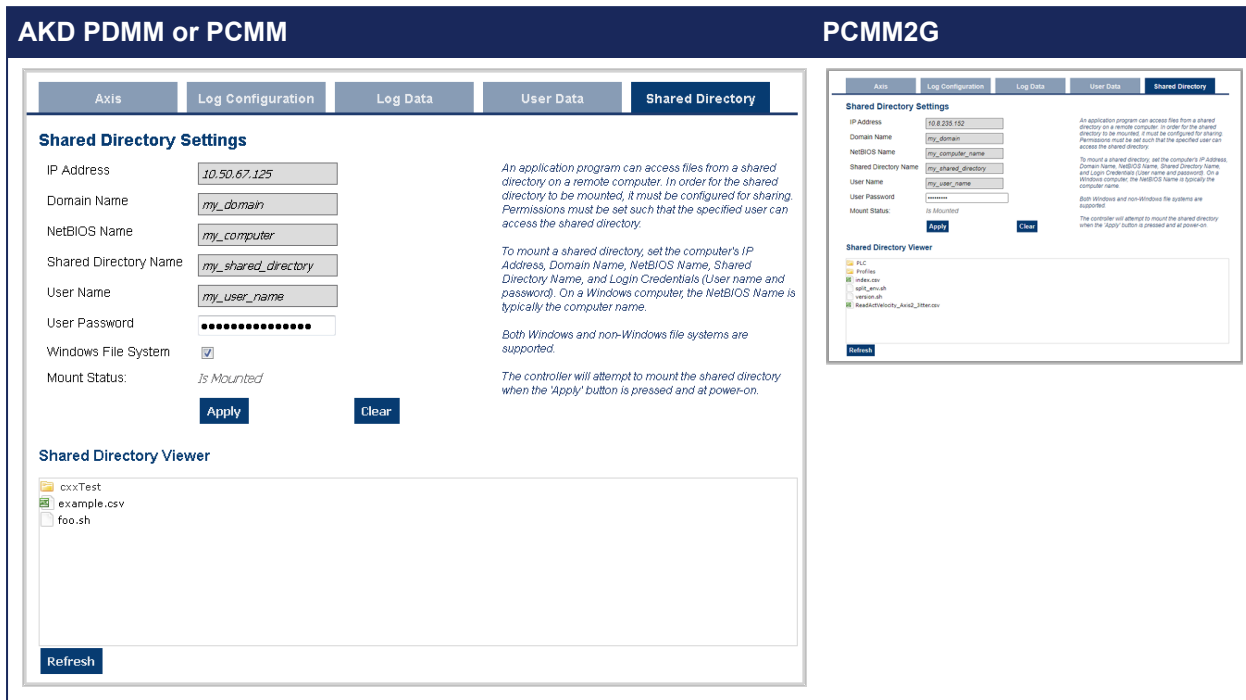

8.9.7.5.1 Field Descriptions

These fields must be set to connect to the share.

NOTE

See this Microsoft article [File Sharing Over a Network in Windows](#) to share a directory.

Field	Description
IP Address	Enter the IP Address of the computer that has a shared directory.
Domain Name	The network domain of the computer that is sharing the directory. This field may or may not be necessary.
NetBIOS Name	The unique name that identifies the computer on the network. For Windows computers, this is typically the computer name.
Shared Directory Name	Enter the name of the shared directory as defined on the remote computer. The contents of this directory is listed in the Shared Directory Viewer .
User Name	The name of a user allowed access to the shared directory. If the user name is a domain user (instead of a local user), the computer that hosts the shared folder must be connected to the domain to validate the name.
User Password	The password of a user allowed access to the shared directory.

Field	Description
Windows File System	<p>Indicate whether the remote computer is Windows or a different operating system. This is used to automatically set file permissions.</p> <p>NOTE</p> <p>This checkbox is not visible for PCMM2G. File permissions set on the remote computer are automatically managed on PCMM2G.</p>
Mount Status	This field indicates whether the directory Is Mounted or Is Not Mounted .
Apply	<p>Click this button to:</p> <ul style="list-style-type: none"> • Mount the share. • Save the configuration to flash memory so it can be automatically mounted at power-on. <p>This button is disabled when the application is running and when the user is not logged in.</p>
Clear	<p>Click this button to:</p> <ul style="list-style-type: none"> • Clear all the fields. • Unmount the share. • Clear the configuration from flash memory. <p>This button is disabled when the application is running and when the user is not logged in.</p>
Shared Directory Viewer area	<p>This area:</p> <ul style="list-style-type: none"> • lists the contents of a mounted shared directory. • is read-only. <p>NOTE</p> <p>Once the shared directory is mounted, its contents can be navigated in the Shared Directory Viewer section of this tab.</p>
Refresh	Click this button to refresh the contents of the fields and the Shared Directory Viewer area.

TIP

We strongly recommend consulting with your IT department for setting up and connecting to a shared directory. With differences between operating systems and the variability of security settings, this can become challenging.

NOTE

SMB1 must be enabled to use the Shared Directory feature with a Windows file system. Review the [KDN article "Shared Drive in PDMM or PCMM Application Fails to Mount"](#) for information on configuring SMB1 in Windows.

See Shared Directory Path Conventions for more information.

8.9.8 Settings tab



A REGAL REXNORD BRAND

LOGIN | HOME | CONTACT US | ABOUT

KAS Application

Settings

Backup & Restore

Diagnostics

Help



Settings

Note that most of the following features are not available when PLC application is running or online config mode is active

Firmware

Date/Time

Network

File System

USB Flash Drive

User Account

Firmware Information

OS version	1.0.0.00351
Runtime version	4.01.0.92341
Recommended file name	KAS-PCMM2G-Cx-08-OS-{OS version}-RT-{Runtime version}.zip

Firmware Upgrade

Firmware image file ⁽¹⁾ Choose File No file chosen

Upgrade

Reboot

1. Select the new firmware image (.zip) file⁽¹⁾.
2. Click Upgrade to start the updating procedure
3. PCMM2G reboots with the new firmware automatically
4. Press CTRL+F5 to force a page refresh.

⁽¹⁾Firmware images are available at Kollmorgen.com
The .zip file may contain an operating system update file (*.swu), a KAS runtime update file (*.tgz), or both.



A REGAL REXNORD BRAND

Kollmorgen
203A West Rock Road
Radford, VA 24141 USA

© Copyright 2023 Kollmorgen. All rights reserved.

Figure 9-5: Settings tab with Firmware tab

The **Settings** tab is used to:

- View and update the firmware for the KAS Runtime.
 - See "Upgrade the Controller's Firmware" (→ p. 423).
- Change the date or time in the "Date/Time tab" (→ p. 417).
- View the network settings and modify the IP address.
 - See "Network tab" (→ p. 431).
- "Reset the Controller to Factory Settings" (→ p. 385)
- Reset the controller to factory settings.
- AKD PDMM and PCMM: Access the "SD Card Actions" (→ p. 432).
- PCMM2G: Use the "USB Flash Drive tab" (→ p. 432) for a USB flash drive.
- Access the "Change the Web server's User Account Password" (→ p. 433) to change the password.

416 Kollmorgen® | kdn.kollmorgen.com | June 2024

8.9.8.1 Date/Time tab

This tab is used to view or change the current date, time, and Network Time Protocol (NTP) synchronization information.

- "Date/Time and NTP Status" (→ p. 418)
- "Update Date/Time" (→ p. 419)
- "Network Time Protocol (NTP)" (→ p. 420)
- "Set Time Zone" (→ p. 421)

The controller's time zone, NTP server address, NTP synchronization configuration, and the date and time can be manually changed.



A REGAL REXNORD BRAND

[LOGIN](#) | [HOME](#) | [CONTACT US](#) | [ABOUT](#)

KAS Application

Settings

Backup & Restore

Diagnostics

Help



Settings

Note that most of the following features are not available when PLC application is running or online config mode is active

Firmware

Date/Time

Network

File System

USB Flash Drive

User Account

Date/Time and NTP Status

Date/Time	10-06-2023 11:17:53 PM
Time Zone	UTC
NTP Synchronization	Active, Synchronized

Update Date/Time

Date/Time Can't edit while NTP is Active

* The Date/Time value cannot be set if the "Synchronize Date/Time with Server" checkbox is checked.

Network Time Protocol (NTP)

Synchronize Date/Time with Server

NTP Server time1.google.com

Update NTP Server

Set Time Zone

New Time Zone Select Time Zone. Type city name to filter.

Update Time Zone



A REGAL REXNORD BRAND

Kollmorgen
203A West Rock Road
Radford, VA 24141 USA

© Copyright 2023 Kollmorgen. All rights reserved.

Figure 9-6: Date/Time tab with Kollmorgen Manually Defined Time Zones

8.9.8.1.1 Date/Time and NTP Status

The information in this area updates every 30 seconds or when a setting is changed using the Date/Time tab. This area is read-only.

Information Field	Description
Date/Time	This is the local date and time as reported by the controller.

Information Field	Description
Time Zone	This is the time zone used by the controller.
NTP Synchronization	<p>This is the synchronization status for the NTP service. The synchronization is defined in two parts.</p> <ul style="list-style-type: none"> The first part of the status reports: <ul style="list-style-type: none"> Active if the controller is configured to synchronize its time with an NTP server. Disabled if the controller is not configured to synchronize its time with an NTP server. The second part of the status reports: <ul style="list-style-type: none"> Synchronized if the controller is synchronized to an NTP server. Not Synchronized if the controller is not synchronized to an NTP server.
	<p>NOTE</p> <p>The controller stays synchronized for several minutes after disabling NTP synchronization. A Disabled, Synchronized status is possible.</p>

8.9.8.1.2 Update Date/Time

Click in the **Date/Time** field to open the **Date/Time** picker.

Select a new date and time and click **OK**.

The image shows a date/time picker interface. At the top, it displays the month 'October' and the year '2022'. Below this is a calendar grid with days of the week (Sun to Sat) and dates from 1 to 31. The date '24' is circled, indicating it is the selected date. Below the calendar, the time is displayed as '12 : 00 : 00 PM'. At the bottom, there are three buttons: 'OK', 'Cancel', and 'Load Host Date/Time'.

Figure 9-7: Date/Time Picker

Button	Description
OK	Click to load the date and time selected in the Date/Time picker onto the controller.

Button	Description
Cancel	Click to close the Date/Time picker without changing the date/time on the controller.
Load Host Date/Time	Click to copy the date/time from the host (i.e., computer or device running the web browser) onto the controller.

NOTE

The **Date/Time** picker is disabled if the controller is configured to synchronize the date/time with an NTP server or if not logged into the controller.

8.9.8.1.3 Network Time Protocol (NTP)

This area is used to update the NTP settings.

Setting	Description
Synchronize Date/Time with Server	<p>Changing the state of the checkbox immediately changes the configuration on the controller.</p> <ul style="list-style-type: none"> A checked box indicates that an NTP server is used to update the date and time. An unchecked box indicates the controller does not synchronize its time or date with an external server.
NTP Server	<p>This is the address of an NTP server to use for synchronizing the date and time.</p> <ul style="list-style-type: none"> If the controller does not have access to the internet, it is still possible to connect to a local NTP server if the local intranet has an NTP server configured. <ul style="list-style-type: none"> A local NTP server can be useful for manufacturing areas that do not want to connect controllers and other equipment to the internet for security reasons but still want to keep all computer's and controller's date and time synchronized for data collection purposes.
Update NTP Server button	Click the Update NTP button to apply the new NTP server address.
	<p>NOTE</p> <p>The Update NTP button is disabled if not logged into the controller.</p>

8.9.8.1.4.1 Correct an A05 Alarm**NOTE**

If NTP is disabled, and the battery is either not installed or dead on power-up, then the system time is wrong and an "A05" (→ p. 680) alarm is generated.

To prevent an A05 alarm on startup, either:

- Enable NTP (see "Synchronize Date/Time with Server" (→ p. 420)).
- Follow this procedure:

1. Remove power from the controller.
2. Insert a new battery.
3. Power on the controller.
There will likely still be an A05 alarm.
4. Use the "Update Date/Time" (→ p. 419) procedure to set the system time.
5. Power off the controller and wait at least 10 seconds before powering it back on.
6. Verify:

- The A05 alarm does not occur.
- The time is correct on the web page.

8.9.8.1.5 Set Time Zone

This area is used to update the time zone used by the controller.

To set the controller's time zone, select a new time zone from the drop-down box and click the **Update Time Zone** button.

Time zones are often specified by the largest city in that time zone.

Example: The US Eastern Time Zone is specified by **America/New_York**.

Typing the first two or three characters of a city or region name filters the list to easily locate a specific time zone. For New York, typing **ne** reduces the time zone list to two entries.

NOTE

The **Update Time Zone** button is disabled if not logged into the controller using the Web server.

8.9.8.2 File System tab

This tab is used to reset the controller to the factory settings.

NOTE

The steps to reset the controller vary slightly based on the platform.

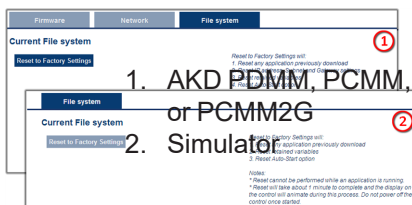

Figure 9-8: File System tab on a Kollmorgen controller's web server and when using Simulator.

Webpage Notes

- This webpage does not update during the reset procedure and can be closed.
- The **Reset to Factory Settings** button is disabled while an application is running.

8.9.8.2.1 Reset the Controller to Factory Settings

⚠ WARNING

Performing a factory reset of the controller should be considered very carefully.

The reset erases everything: User data files, the application, the controller IP address, any retain variables, passwords, shared directory settings, and all log files.

When the **Reset to Factory Settings** button is clicked, the controller is reset to factory default settings.

A confirmation message opens to confirm this action before the function is performed.

8.9.8.2.2.1 Factory Reset Changes

The changes which occur during a reset are:

Erased Items

- User data files.
- Any application previously downloaded.
- Retained variables.
- Shared directory settings.
- Log files.

Defaults Restored

- Password for both the web page and SSH login.
 - See "SSH Login to a Controller" (→ p. 400) and "User Authentication" (→ p. 406).
- Controller network configuration.
 - Examples: IP address, Subnet, and Gateway settings.
- Auto-Start option.

PCMM2G Only

- The SSH keys are regenerated.
 - SSH clients logged on during the factory reset are forced to log in again.
 - All Date and Time settings are reset to default (NTP enabled).

Notes

- The factory reset cannot be performed while an application is running.
- Do not turn off the controller during the reset procedure.
- If the AKD PDMM or PCMM has just been powered up, the B3 button must be held down much longer than 2 seconds.
 - In this case, hold down the button until the 7-segment display shows the B3 menu.
 - See "B3 Menu Button" (→ p. 383).
- Estimated time for factory reset:
 - AKD PDMM and PCMM: 4-5 minutes.
 - PCMM2G: About a minute.
 - The 7-segment display on the controller is animated during this process.
- After the factory reset is complete, the controller is powered down and restarted automatically.
- After the controller is restarted, the controller IP address may change based on the controls rotary switch.
 - If the rotary switch is at position 0 (zero), the same IP address as before should be assigned to the controller.
 - If the rotary switch is set to 1-9, a pre-configured IP address is defined.
 - This IP address must be taken into account when trying to reconnect to the webpage using a web browser.

8.9.8.3 Firmware tab

The **Firmware** tab is used to:

- "View Firmware Information" (→ p. 427)
- "Upgrade the Controller's Firmware" (→ p. 423)



Settings

Note that most of the following features are not available when PLC application is running or online config mode is active

Firmware

Date/Time

Network

File System

USB Flash Drive

User Account

Firmware Information

Boot Loader version	2022.01.08
OS version	1.0.0.00382
Runtime version	4.02.0.94163
Recommended file name	KAS-PCMM2G-Cx-08-OS-{OS version}-RT-{Runtime version}.zip

Firmware Upgrade

Firmware image file ⁽¹⁾ **Choose File** No file chosen

Upgrade

Reboot

1. Select the new firmware image (.zip) file⁽¹⁾.
2. Click Upgrade to start the updating procedure
3. PCMM2G reboots with the new firmware automatically
4. Press CTRL+F5 to force a page refresh.

⁽¹⁾Firmware images are available at Kollmorgen.com
The .zip file may contain an operating system update file (*.swu), a KAS runtime update file (*.tgz), or both.

Figure 9-9: Firmware tab

See Also

- "Booting the AKD PDMM or PCMM Controller" (→ p. 374)
- "Booting the PCMM2G Controller" (→ p. 375)
- "Recover Using the Web server" (→ p. 428)

8.9.8.3.1 Upgrade the Controller's Firmware

This procedure is used to upgrade the controller's firmware using the web server.

1. Identify the controller's IP address.
See "View the Controller IP Address" (→ p. 384).
2. Open a web browser and enter the controller's IP address.
The Web server KAS Home window opens.

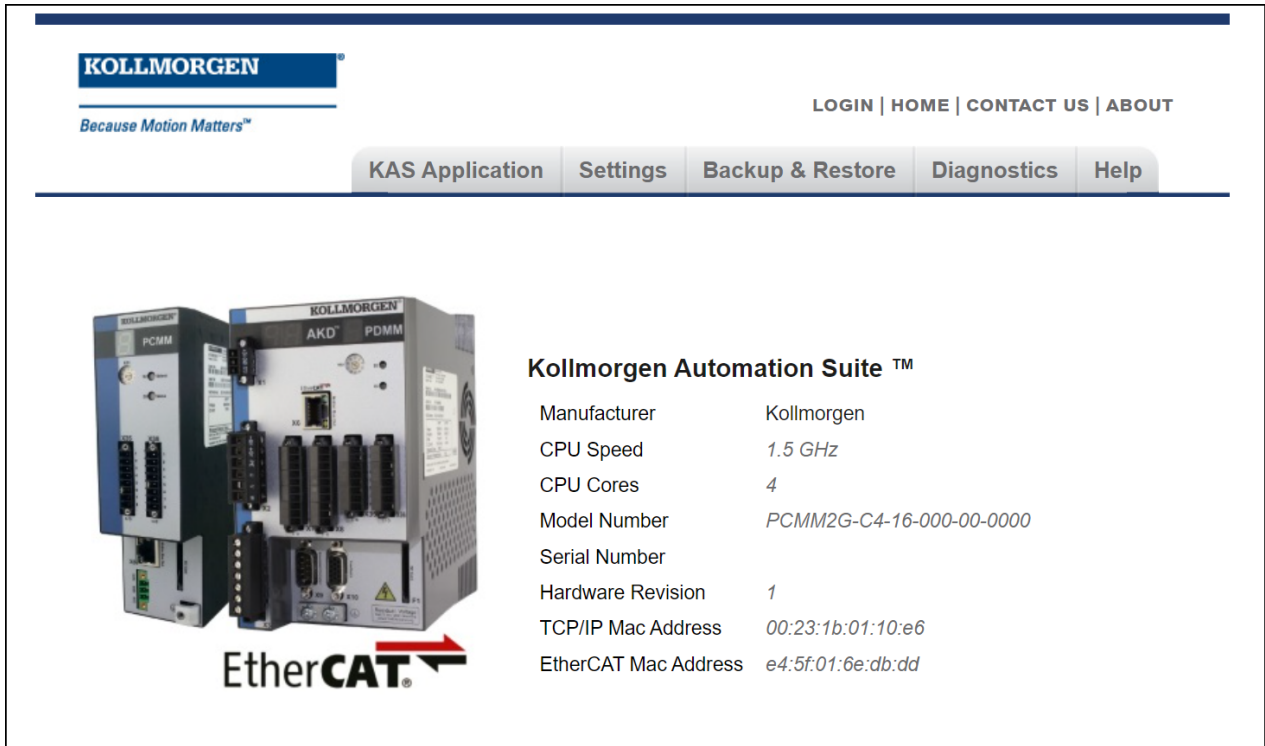

Figure 9-10: KAS Home window

3. Login to the controller.
4. Click the **Settings** tab.
5. Click the **Firmware** tab.



Settings

Note that most of the following features are not available when PLC application is running or online config mode is active

Firmware

Date/Time

Network

File System

USB Flash Drive

User Account

Firmware Information

Boot Loader version	2022.01.08
OS version	1.0.0.00382
Runtime version	4.02.0.94163
Recommended file name	KAS-PCMM2G-Cx-08-OS-{OS version}-RT-{Runtime version}.zip

Firmware Upgrade

Firmware image file ⁽¹⁾ **Choose File** No file chosen

Upgrade

Reboot

1. Select the new firmware image (.zip) file⁽¹⁾.
2. Click Upgrade to start the updating procedure
3. PCMM2G reboots with the new firmware automatically
4. Press CTRL+F5 to force a page refresh.

⁽¹⁾Firmware images are available at Kollmorgen.com
The .zip file may contain an operating system update file (*.swu), a KAS runtime update file (*.tgz), or both.

Figure 9-11: Firmware tab - Upgrade Firmware area

6. In the **Firmware Information** area, verify the **Recommended file name** for the upgrade file to download and use.

Examples:

AKD PDMM and PCMM

Firmware Information

Firmware version	4.01.0.91992
Recommended file name	KAS-PDMM-M-M1EC-{version}.img

PCMM2G

Firmware Information

OS version	1.0.0.00281
Runtime version	4.01.0.91992
Recommended file name	KAS-PCMM2G-Cx-08-OS-{OS version}-RT-{Runtime version}.zip

7. Open the applicable controller product web page:

- [AKD® PDMM Programmable Drive, Multi-Axis Master](#)
 - [PCMM: Programmable Controller, Multi-axis Master](#)
8. In the **Software** tab, under the **Title** column, locate the appropriate firmware upgrade file.
 9. Click the link for the upgrade file.
The file automatically downloads to the location designated for the browser.
 10. Close the browser window.
 11. Return to the KAS the **Firmware** tab.
 12. In the **Upgrade Firmware** area, click the **Choose File** button.
A Windows Explorer window opens.

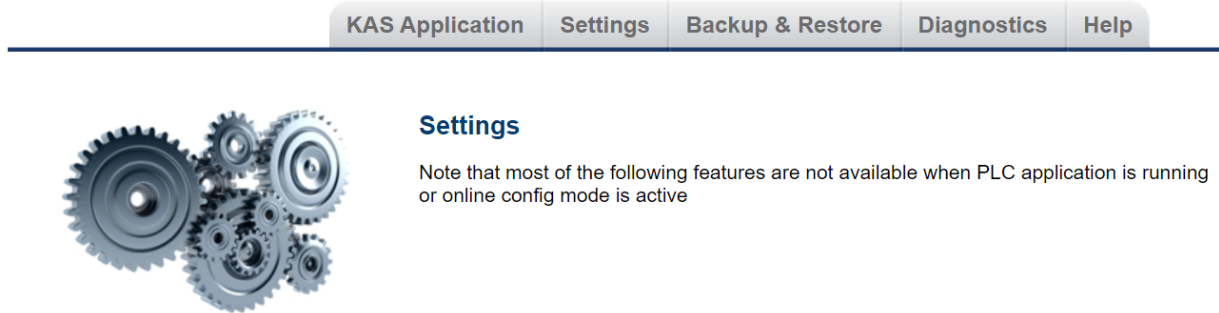

Firmware Information

Boot Loader version	2022.01.08
OS version	1.0.0.00382
Runtime version	4.02.0.94163
Recommended file name	KAS-PCMM2G-Cx-08-OS-{OS version}-RT-{Runtime version}.zip

Firmware Upgrade

Firmware image file ⁽¹⁾ **Choose File** No file chosen

Upgrade

Reboot

1. Select the new firmware image (.zip) file⁽¹⁾.
2. Click Upgrade to start the updating procedure
3. PCMM2G reboots with the new firmware automatically
4. Press CTRL+F5 to force a page refresh.

⁽¹⁾Firmware images are available at Kollmorgen.com
The .zip file may contain an operating system update file (*.swu), a KAS runtime update file (*.tgz), or both.

13. Search for and select the firmware file downloaded in Step 9.
14. Click **Open** to select the file and close the window.
15. Click the **Upgrade** button to start the process.

TIP

If the **Upgrade** button is disabled, log into the Web server.
Click **Login** at the top of the web page and enter the password.

A message and a throbber are shown across the web page, indicating that maintenance is in progress.



The 7-segment display on the controller animates with chasing lights.

IMPORTANT

Do **not** refresh the web page until firmware upgrade is completed.
If performing a boot loader upgrade, do **not** power-off or restart the PCMM2G until the boot loader upgrade is completed.

Successful Upgrade: The controller automatically reboots with new firmware.

When the reboot is complete, the user is logged out of the controller.
The webserver displays a message to indicate the user has been logged out.

Unsuccessful Upgrade

The Web server indicates the reason for the upgrade failure.

Example: Incompatible Firmware

AKD PDMM and PCMM Error Message

An error message, similar to this, appears if the wrong firmware file was downloaded:

```
The file provided is not compatible with this device.  
The file name should be...  
"KAS-PDMM-M-MCEC-{version}.img"
```

PCMM2G Runtime Error Message

```
Minimum runtime version requirement not met.
```

16. Press **<CTRL+F5>** to force the controller's web browser to refresh the page.
The new firmware version appears in the **Firmware Information** area.

See Also

- "Booting the AKD PDMM or PCMM Controller" (→ p. 374)
- "Booting the PCMM2G Controller" (→ p. 375)
- "Recover Using the Web server" (→ p. 428)
- "PCMM2G - File Naming Conventions" (→ p. 858)

8.9.8.3.2 View Firmware Information

The firmware installed on the controller is shown in the **Firmware Information** area.



Settings

Note that most of the following features are not available when PLC application is running or online config mode is active

Firmware

Date/Time

Network

File System

USB Flash Drive

User Account

Firmware Information

Boot Loader version	2022.01.08
OS version	1.0.0.00382
Runtime version	4.02.0.94163
Recommended file name	KAS-PCMM2G-Cx-08-OS-{OS version}-RT-{Runtime version}.zip

Firmware Upgrade

Firmware image file ⁽¹⁾ **Choose File** No file chosen

Upgrade

Reboot

1. Select the new firmware image (.zip) file⁽¹⁾.
2. Click Upgrade to start the updating procedure
3. PCMM2G reboots with the new firmware automatically
4. Press CTRL+F5 to force a page refresh.

⁽¹⁾Firmware images are available at Kollmorgen.com
The .zip file may contain an operating system update file (*.swu), a KAS runtime update file (*.tgz), or both.

Figure 9-12: Firmware tab - Firmware Information area for PCMM2G

8.9.8.3.3.1 File Types

The firmware file types are different between the controllers.

- "AKD PDMM and PCMM - File Naming Conventions" (→ p. 857)
- "PCMM2G - File Naming Conventions" (→ p. 858)

See Also

- "Booting the AKD PDMM or PCMM Controller" (→ p. 374)
- "Booting the PCMM2G Controller" (→ p. 375)
- "Recover Using the Web server" (→ p. 428)

8.9.8.3.4 Recover Using the Web server

If the controller detects a problem in the firmware, the 7-segment display shows . This means a firmware recovery is needed.

The recovery modes are:

- "AKD PDMM and PCMM Web server Recovery" (→ p. 428)
- "PCMM2G Web server Recovery" (→ p. 429)

8.9.8.3.5.1 AKD PDMM and PCMM Web server Recovery

AKD PDMM and PCMM enter Recovery Mode automatically.

- Recovery Mode is used to select and upgrade a firmware image file containing the KAS Runtime image on the AKD PDMM or PCMM.
- When Recovery Mode cannot be automatically accessed, press and hold B2 at boot to force the AKD PDMM or PCMM to boot into Recovery Mode.

⚠ WARNING

The Recovery Mode allows any firmware image file to be loaded into the controller's flash memory. The Recovery Mode does NOT verify the selected firmware file is compatible with the hardware model. Verify the **Recommended File Name** matches the selected firmware file. If an incompatible firmware file is loaded into the AKD PDMM's or PCMM's flash memory, the AKD PDMM or PCMM fails to boot into the Runtime image and fails to automatically boot into Recovery Mode. To recover from this situation requires manually booting into Recovery Mode. See "Boot from Recovery Image (B2 Button)" (→ p. 384).

8.9.8.3.6.2 PCMM2G Web server Recovery

ⓘ IMPORTANT

Recovery Mode is **not** automatic for the PCMM2G.

8.9.9 Recovery USB Flash Drive

There are two kinds of Recovery USB drives:

- "Production Image Recovery Procedure" (→ p. 429)
- "Customer Image Recovery" (→ p. 430)

8.9.10 Production Image Recovery Procedure

The Production-image Recovery USB flash drive is imaged using a production release using this procedure:

1. Download and install the software from the [balenaEtcher](#) website.
2. Download the PCMM2G recovery firmware **wic.bz2** image file from the Kollmorgen [Downloads](#) page. It is recommended to download the same version of the recovery image as the existing Operation System and Runtime image.
See "Recovery Operating System (OS) + KAS Runtime (RT) - File Naming Convention" (→ p. 860).
3. Open the balenaEtcher software.
4. Use the balenaEtcher instructions to create the Recovery USB flash drive using the **wic.bz2** file downloaded in Step 2.
5. Insert the Recovery USB flash drive into X37 USB Port of the PCMM2G.
6. Hold the B2 button and power-cycle the PCMM2G.



7. Release the B2 button anytime after the 7-segment display shows .
See "Booting the PCMM2G Controller" (→ p. 375).



If a  7-segment display appears while bootup with the B2 button held down, there is not a bootable drive inserted in the X37 USB Port.

8. When the PCMM2G is in Recovery Mode, connect to the controller from a web browser using its IP address (e.g., <http://192.168.0.101>).

- Click the **Recover** button on this web page to start the recovery procedure.

KOLLMORGEN
Because Motion Matters™

HOME | CONTACT US | ABOUT

Settings Help

Recovery Mode

This Recovery page is displayed on the web server when a problem is detected while booting the controller, or if you have forced the controller into Recovery Mode by holding down the push button B2. This page provides the ability to recover the Operating System and KAS Runtime image on the PCMM2G flash.

Firmware

Recovery Firmware Information

OS version: 1.0.0.00153
Runtime version: 4,00,0,89240

Firmware Recovery

Recover
Reboot

- Click Recover button to start the recovery procedure.
- After the recovery is finished, Reboot the controller to active new firmware.

* Unplug the Recovery USB drive from the controller after the recovery procedure is complete.

Notes:
* When Production-imaged Recovery USB drive is used, the controller is restored to a state when the controller was first powered on with that Production release.
* When customer-imaged Recovery USB drive is used, the controller is restored to the same state when the customer performed the Controller Backup procedure.

- Reboot the controller after the recovery is finished.

It is recommended to:

- Connect to the controller from the web browser and verify both the firmware OS and Runtime versions are as expected.
- Unplug the Recovery USB drive from the controller after the recovery procedure is completed.

If you used the:

- Production-image Recovery USB flash drive, you must reprogram the controller with your configuration.
- Customer-imaged Recovery USB flash drive, all settings are restored and the controller is fully operational.

When using the Production-image Recovery USB flash drive to perform Recovery, the controller is restored to a state when the controller was powered on with that Production release.

8.9.11 Customer Image Recovery

The Customer-imaged backup Recovery USB flash drive is generated using the "Controller Backup and Restore" (→ p. 387) procedure.

ⓘ IMPORTANT

It is recommended to create the Recovery USB flash drive using the "Controller Backup and Restore" (→ p. 387) procedure every time the firmware on the controller is updated. This procedure creates an exact backup of the controller unlike the Production-image Recovery USB flash

drive.

This is an important difference while recovering the controller.

When using the customer-imaged Recovery USB flash drive to perform the Recovery, the controller is restored to the same state when the customer performed the Controller Backup procedure.

See Also

- "Controller Boot Startup Script" (→ p. 380)
- "Boot from Recovery Image (B2 Button)" (→ p. 384)
- "Bootting the PCMM2G Controller" (→ p. 375)

8.9.11.1 Network tab

This tab is used to:

- view the current rotary switch position of the controller and its MAC address.
- Manually change the controller's IP address.

The screenshot shows the 'Network' tab of the controller's settings. It includes a 'Network Settings' section with a rotary switch value of 1 and a MAC address of 00:23:1b:00:df:df. Below that is the 'Manual IP Address **' section with input fields for IP Address (10.50.67.95), Subnet Mask (255.255.255.0), and Default Gateway. There are 'Apply' and 'Reboot' buttons at the bottom. A note on the right explains the rotary switch positions: 0 for DHCP, 1 for manual IP address (default 192.168.0.101), and 2-9 for static IP addresses (192.168.0.10x).

Figure 9-13: Example: Kollmorgen controller with a manually defined IP address.

8.9.11.1.1 Rotary Switch

The rotary switch on a Kollmorgen controller is set from a 0 to 9 position.

Switch Position	Description
Position 0	<ul style="list-style-type: none"> • The controller tries to get an IP address from a DHCP server. • If the DHCP fails, the controller uses AutoIP to get a usable IP address.
Position 1	Either: <ul style="list-style-type: none"> • The default static IP address of 192.168.0.101. • A custom IP address.
Position 2-9	<ul style="list-style-type: none"> • The controller is pre-configured with static IP addresses. • The IP addresses range is from: <ul style="list-style-type: none"> • 192.168.0.102 (Position 2) to 192.168.0.109 (Position 9)

TIP

If a DHCP server is not present, the drive assumes an Automatic Private IP Address of the form 169.254.x.x.

8.9.11.1.2 Manually Change the IP Address

To connect and use your controller within your computer network, you may configure its IP address by using the web server.

1. Verify the RS1 on the controller is set to position 1.
2. Open a web browser and enter the controller's IP address.
The controller's web page opens.
See "View the Controller IP Address" (→ p. 384) to find this address.
3. Click the **Settings** tab.

4. Click the **Network** tab.
5. In the **Manual IP Address** area:
 - a. Enter the **IP Address**.
 - b. Enter the **Subnet mask**.
The default is 255.255.255.0.
 - c. Optional: Enter the **Default gateway** address if the controller is outside the local network.
6. Click **Apply**.
7. Click **Reboot**.
8. Verify the new IP address shows in the 7-segment display on the controller.

TIP

It is recommended to NOT use leading zeroes when entering an IP address. The webserver automatically configures numbers with leading zeroes as octal values. Example: Use **10.1.1.10** instead of **010.001.001.010**.

8.9.11.2 SD Card tab

IMPORTANT

This tab is only visible for AKD PDMM AND PCMM controllers.

8.9.11.2.1 SD Card Actions

The **Format** function formats the SD card as FAT32, erasing all data from the card.

NOTE

This function cannot be performed while an application is running.

8.9.11.3 USB Flash Drive tab

IMPORTANT

This tab is only visible for PCMM2G controllers.

This tab is used to format the USB flash drive as FAT32.

NOTE

PCMM2G supports only one USB flash drive. If a USB hub is used to expand the USB ports on the PCMM2G, use only a single USB flash drive in the hub.

IMPORTANT

All data is erased from the USB flash drive. The Format function cannot be performed while an application is running.

The screenshot shows the Kollmorgen KAS IDE interface. At the top left is the Kollmorgen logo with the tagline "Because Motion Matters™". To the right are navigation links: LOGIN | HOME | CONTACT US | ABOUT. Below this is a menu bar with tabs: KAS Application, Settings, Diagnostics, and Help. The main content area is titled "Settings" and includes a gear icon. A note states: "Note that most of the following features are not available when PLC application is running or online config mode is active". Below the note is a horizontal menu with tabs: Firmware, Network, File System, USB Flash Drive (selected), and User Account. Under the "USB Flash Drive" tab, there is a section titled "USB Flash Drive Actions" with a "Format" button. To the right of the button, text reads: "The Format function formats the USB Flash Drive as FAT32, erasing all data from the drive." Below this is a "Notes:" section with the text: "* This function cannot be performed while an application is running."

Figure 9-14: USB Flash Drive tab

8.9.11.4 Change the Web server's User Account Password

To change the password, enter the current password and the new password twice.

The screenshot shows the Kollmorgen KAS IDE interface. At the top left is the Kollmorgen logo with the tagline "A REGAL REYNOLD BRAND". To the right are navigation links: LOGIN | HOME | CONTACT US | ABOUT. Below this is a menu bar with tabs: KAS Application, Settings, Backup & Restore, Diagnostics, and Help. The main content area is titled "Settings" and includes a gear icon. A note states: "Note that most of the following features are not available when PLC application is running or online config mode is active". Below the note is a horizontal menu with tabs: Firmware, Date/Time, Network, File System, USB Flash Drive, and User Account (selected). Under the "User Account" tab, there is a section titled "Change Password" with three input fields: "Current Password", "New Password", and "Confirm New Password". Below the input fields is a "Change Password" button.

The new password must meet these conditions:

- The password must be 6-20 characters long.
- The password cannot contain:
 - Ampersands (&)
 - Number sign(#)
 - Quotes (' and ")
 - Semicolons (;)
 - Slashes (/ and \)
 - Spaces

8.9.11.4.1 I Forgot My Password

When this happens, set a new password from the IDE.

1. Open the Web server from the IDE.
2. Click the **Settings** tab.
3. Click the **User Account** tab.
4. Enter and confirm a new password.

This procedure is used to create a new password without entering the current one.

8.9.12 Backup and Restore from the Web server

The Backup and Restore functions are used to replicate a Kollmorgen controller.

The controller data is replicated on these storage devices:

- AKD PDMM and PCMM: SD card.
- PCMM2G: USB flash drive.

8.9.12.1 All Controllers

The elements that are backed up or restored for all controllers are the:

- Controller firmware.
- Network configuration.
- PLC Application.
- "Retain Variables" (→ p. 707).
- Shared Directory settings
- User data files.
 - See "User Data tab" (→ p. 413) for more information.
- Web server and SSH user accounts configuration.

8.9.12.2 PCMM2G Backup / Restore Only

- Backup:
 - AKD and/or AKD2G firmware packages and their respective drive parameters.
 - EtherCAT network topology.
- Restore:
 - The drive's data and firmware is copied from the USB flash drive to the controller flash when the **Restore Controller** function is selected.
 - The **Restore EtherCAT Devices** function should be selected for restoring the data and the firmware of any replaced AKD or AKD2G drives.

The Backup and Restore processes:

- Cannot be performed while an application is running.
- Takes several minutes to complete.
 - Do not power off the controller once started.
- The controller is rebooted after a Restore.

ⓘ IMPORTANT

AKD PDMM or PCMM do not allow restoring the controller from the PCMM2G backup.
PCMM2G does not allow restoring the controller from the AKD PDMM or PCMM backups.

The AKD PDMM and PCMM are available with different CPU variants (800MHz, 1.2GHz single core, and 1.2GHz dual core).

- The AKD PDMM and PCMM models have the same functionality but, because of CPU speed differences, an application designed for the 1.2GHz model may not execute as expected on the 800MHz model.
 - An application designed for a single core CPU model may not execute as expected on the dual core model.
- The Restore:
 - Does **not** allow a higher speed model to be replaced with a lower speed model.
 - Does allow a lower speed model to be replaced with a higher speed model if the Backup contains the model-specific Runtime firmware file.

Backup File Source	PCMM2G Restore	AKD PDMM or PCMM 800MHz Restore	AKD PDMM or PCMM 1.2GHz Single Core Restore	AKD PDMM or PCMM 1.2GHz Dual Core Restore
PCMM2G Backup	Yes	No	No	No
800MHz Backup	No	Yes	Yes If 1.2GHz Runtime file is included in the Backup.	No
1.2GHz Single Core Backup	No	No	Yes	No
1.2GHz Dual Core Backup	No	No	No	Yes

🔗 TIP

This section provides an overview of the backup and restore processes.
See "Backup and Restore tab" (→ p. 390) for more information.

8.9.12.3 Backup tab

Backup either the:

- "AKD PDMM or PCMM Controller Backup" (→ p. 435)
- "PCMM2G Controller and EtherCAT Devices Backup" (→ p. 436)
- "EtherCAT Devices Backup" (→ p. 438)

8.9.12.3.1 AKD PDMM or PCMM Controller Backup

This function is used to replicate a PCMM or the controller portion of the AKD PDMM.

Click the button to save the data to the SD card.

- The 1.2GHz single core Runtime firmware file is optional.
- If the 1.2GHz single core Runtime firmware file is **not** included, an 800MHz single core model can only be replaced with another 800MHz single core model.
- If provided, an 800MHz single core model can be replaced with a 1.2GHz single core model.

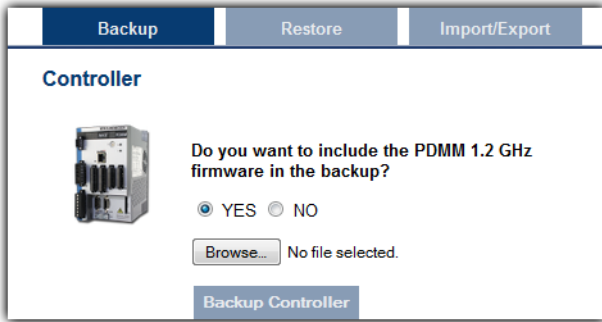

After starting, a confirmation message opens to confirm the backup.

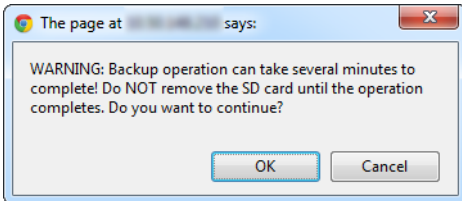

Click **OK** to continue.

See Also

- "EtherCAT Devices Backup" (→ p. 438)
- "PCMM2G Controller and EtherCAT Devices Backup" (→ p. 436)

8.9.12.3.2 PCMM2G Controller and EtherCAT Devices Backup

All firmware packages are available at Kollmorgen.com.

This function is used to replicate a PCMM2G.

Backup Controller and EtherCAT Devices are used to replicate a PCMM2G.

The elements that are backed up or restored for all controllers are the:

- Controller firmware.
- Network configuration.
- PLC Application.
- "Retain Variables" (→ p. 707).
- Shared Directory settings
- User data files.
 - See "User Data tab" (→ p. 413) for more information.
- Web server and SSH user accounts configuration.

8.9.12.3.3.1 PCMM2G Backup / Restore Only

- Backup:
 - AKD and/or AKD2G firmware packages and their respective drive parameters.
 - EtherCAT network topology.
- Restore:
 - The drive's data and firmware is copied from the USB flash drive to the controller flash when the **Restore Controller** function is selected.
 - The **Restore EtherCAT Devices** function should be selected for restoring the data and the firmware of any replaced AKD or AKD2G drives.

Notes

- This function cannot be performed while an application is running.
- Backup Controller takes several minutes to complete.
 - Do not power off the controller once started.

Backup EtherCAT devices save the network topology, the AKD and/or AKD2G drive's firmware and parameters.

- For EtherCAT devices backup operation, a matching AKD and/or AKD2G firmware package is required.
 - If a matching firmware package exists on the controller, it is used for future backups.
 - If a matching firmware package **does not** exist on the controller, you will be asked to provide it.

Click the button to save the data to the USB flash drive.



After starting, a confirmation message opens to confirm the backup.

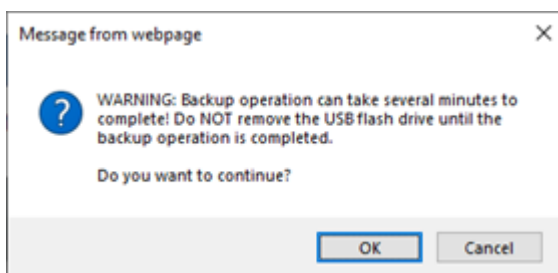

Click **OK** to continue.

If a copy of the drives' firmware package is **not** present on the controller, you are prompted to provide one or more of these packages depending on the drive models present on the controller EtherCAT network

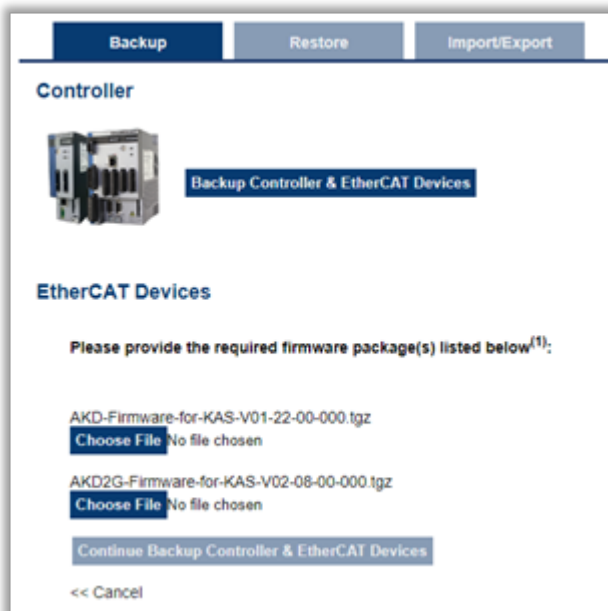

Provide the required firmware packages to continue with the backup function.

Click the **Continue Backup Controller & EtherCAT Devices** button.

See Also

- "EtherCAT Devices Backup" (→ p. 438)
- "AKD PDMM or PCMM Controller Backup" (→ p. 435)

8.9.12.3.4 EtherCAT Devices Backup

This function replicates the network topology and the AKD, AKD PDMM, AKD-C, AKD-N, and AKD2G drive's unique ID, firmware, and data.

To accomplish the backup, a copy of the firmware package is required.

Different scenarios are possible when clicking this button:

- "Scenario 1 - Archived Firmware Copy = Firmware used on Drives" (→ p. 438)
- "Scenario 2 - Archived Firmware Copy Not = Network Configuration" (→ p. 438)
- "Scenario 3 - Only Unique ID Backed Up" (→ p. 438)

8.9.12.3.5.1 Scenario 1 - Archived Firmware Copy = Firmware used on Drives

- If an archived copy of the same firmware package is on the controller as is used on the drives, clicking the button starts the backup.
 - If a copy of the firmware package cannot be found, you are prompted to browse for one or more.
- A link to the Kollmorgen website is provided; all firmware packages are on the site.

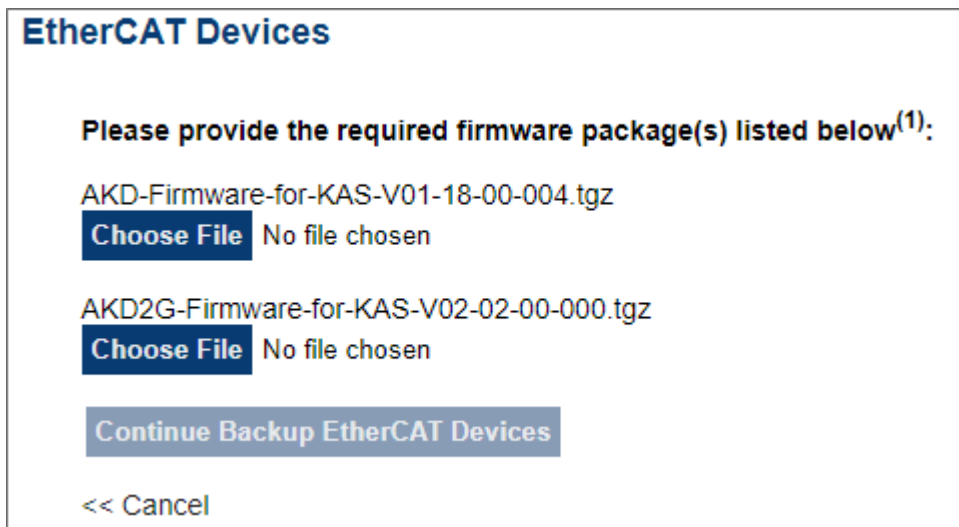

8.9.12.3.6.2 Scenario 2 - Archived Firmware Copy Not = Network Configuration

- If an archive is found on the controller, but it **does not match** the network configuration, you are prompted to browse for one or download one from the website.
- This message appears if the EtherCAT network topology discovered during backup does not match the topology expected by the KAS application:
 - The message shows the number of discovered devices, the number that were expected, and how many are disconnected.

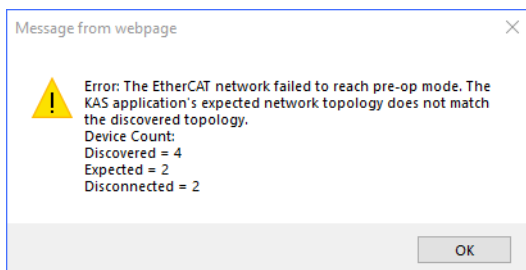

8.9.12.3.7.3 Scenario 3 - Only Unique ID Backed Up

- For all other EtherCAT devices (e.g., couplers, IOs, ServoStar drives, and third-party devices), only the unique ID is backed up.

TIP

The firmware package files on the Kollmorgen website are saved in a .ZIP format. You must unzip the download to access the .TGZ file .

See Also

- "AKD PDMM or PCMM Controller Backup" (→ p. 435)
- "PCMM2G Controller and EtherCAT Devices Backup" (→ p. 436)

8.9.12.4 Restore tab**8.9.12.4.1 Restore Controller**

The Backup and Restore functions are used to replicate a Kollmorgen controller.

The controller data is replicated on these storage devices:

- AKD PDMM and PCMM: SD card.
- PCMM2G: USB flash drive.

The elements that are backed up or restored for all controllers are the:

- Controller firmware.
- Network configuration.
- PLC Application.
- "Retain Variables" (→ p. 707).
- Shared Directory settings
- User data files.
 - See "User Data tab" (→ p. 413) for more information.
- Web server and SSH user accounts configuration.

8.9.12.4.2 PCMM2G Backup / Restore Only

- Backup:
 - AKD and/or AKD2G firmware packages and their respective drive parameters.
 - EtherCAT network topology.
- Restore:
 - The drive's data and firmware is copied from the USB flash drive to the controller flash when the **Restore Controller** function is selected.
 - The **Restore EtherCAT Devices** function should be selected for restoring the data and the firmware of any replaced AKD or AKD2G drives.

8.9.12.4.3 Restore EtherCAT Devices

This function automatically restores the data and firmware of any replaced AKD or AKD2G drives and the station alias of other EtherCAT devices.

8.9.12.4.4 Advanced

Click this button to create a map of the network and its components.

- If a valid firmware file is found, and the current topology matches the backup file, select the devices that need to be restored.

- Click **Restore EtherCAT Devices** restores the drive's firmware.

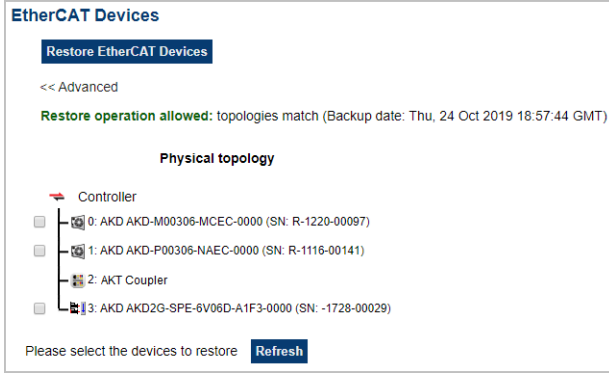

8.9.12.5 Import / Export tab

These functions are used to:

- Save a copy of the controller and EtherCAT configurations backup file to a computer.
- Import the backup file to be used for restore functions.

8.9.12.5.1 Controller

Button	Description
Export Controller Backup	Click this button to save a backup of the controller firmware and configuration to a computer. The filename of the backup exported to the computer are: <ul style="list-style-type: none"> • AKD PDMM or PCMM: kas-controller-backup.tgz. • PCMM2G: kas-controller-2g-backup.zip. • The file may be renamed to help identify the backup file with the machine
Choose File	Click this button to select a previously exported backup file to be imported.
Replace Controller Backup	Click this button to import the selected backup file, replacing any existing backup.

8.9.12.5.2 EtherCAT Devices

Button	Description
Export EtherCAT Backup	Click this button to save a backup of the EtherCAT configuration to a computer. <ul style="list-style-type: none"> • The filename of the backup exported to the computer is kas-network-backup.tgz. • The file can be renamed to help identify the backup file with the machine.
Choose File	Click this button to select a previously exported backup file to be imported.
Replace EtherCAT Backup	Click this button to import the selected backup file, replacing any existing backup.

8.9.13 Diagnostic tab

This page has information about the hardware status (e.g., storage space, memory, CPU temperature) and errors and alarms.



Diagnostics

[Errors and Alarms](#)
HW Status
[Crash Reports](#)
[EtherCAT](#)

Storage space (used/total) 681.6 / 1705.9[MB]

* refreshed automatically

Available memory 7068.8[MB]

CPU usage* 0%

CPU temp* 58.9[C]

CPU fan present False

[Refresh](#)
[Reboot](#)

8.9.13.1 Errors and Alarms

The Errors and Alarms tab and the 7-segment display shows controller errors or alarms generated by the system.

Controller	Description
Storage Space	This is both the used and total available amount of storage space in megabytes (MB). <ul style="list-style-type: none"> • Used is the amount of file space currently being used by all files in flash memory. • Total is the total amount of file space available for files in flash memory.
Available Memory	This is the amount of RAM memory available on the Controller.
CPU Usage	This is the current load on the CPU. <ul style="list-style-type: none"> • If the load goes over 90%, the field turns red. • AKD PDMM and PCMM: CPU usage is the average of all the cores. • PCMM2G: CPU usage is measured across the CPU cores that run the motion engine and PLC program.
CPU Temp	This is the temperature of the CPU in Celsius. <ul style="list-style-type: none"> • If the CPU temperature is greater than the CPU warning limit, the temperature background color changes to yellow. • If the CPU temperature is greater than the CPU critical temperature, the temperature background color changes to red. • PCMM: The normal operating range is 0 °C to 125 °C. • PCMM2G: The normal operating range is 0 °C to 81 °C.

Controller	Description
CPU Fan Present	This is either True or False , depending if there is a CPU fan present in the controller.
Refresh	Click this button to refresh the Hardware Status information.
Reboot	Click this button to reboot the web server.

NOTE
 A common error or alarm is due to the flash memory being full. This is often caused by heavy use of the PLC Advanced File function blocks. Some errors or alarms are only cleared by powering off and restarting the Kollmorgen controller.

- The **Refresh** button updates the list.
- The **Clear** button removes the contents of this tab.

CODE	DESCRIPTION	REMEDY
E12	Not enough flash memory available.	Clean-up the flash memory by removing log files, application programs, recipes, or other data files.
A12	Flash memory is low on free space.	Clean-up the flash memory by removing log files, application programs, recipes, or other data files. Reset to factory defaults.

Refresh Clear

See "Controller Error and Alarm Descriptions" (→ p. 668) for a complete list of codes.

TIP
 Axis errors can be seen in the KAS Application **Axis** tab.

8.9.13.2 Hardware Status

IMPORTANT
 Do not try to refresh the web page until the server has rebooted.

8.9.13.3 Crash Reports

The files shown on the Crash Reports tab are reports of the process that failed if there is a crash.

NOTE
 These archives may be sent to Kollmorgen for analysis:
 .GZ for AKD PDMM and PCMM ("AKD PDMM and PCMM" (→ p. 442) image)
 .ZIP for PCMM2G ("PCMM2G" (→ p. 442) image)

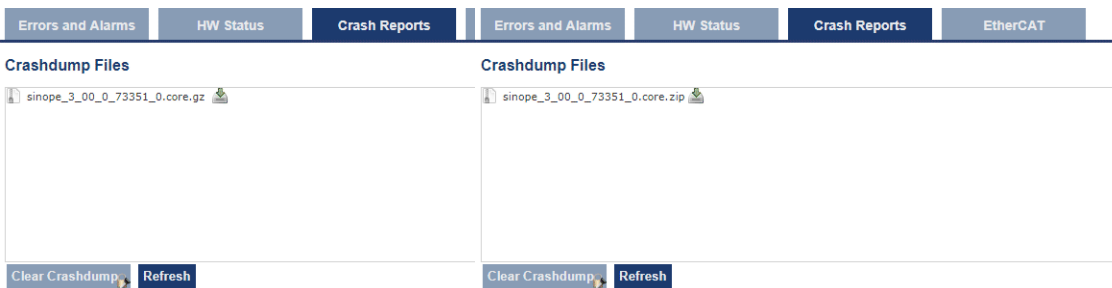

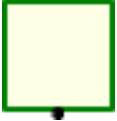

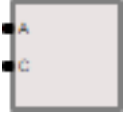



Figure 9-15: AKD PDMM and PCMM

Figure 9-16: PCMM2G

8.9.13.4 EtherCAT Diagnostics tab

This tab is used to identify failed or degraded connections between nodes, (e.g., Controller, drives, and I/O) and non-accessible nodes or cables.

- The tab's content includes a visualization of the network topology, and it's last-known state.
- The tab contents are updated using the **Refresh** button.

Element	Description	Meaning
	Green Box	This is a node with normal communication.
	Red Box	This is a node that is experiencing communication errors.
	Gray Box	This is a node which cannot be reached, but was known to exist.
	Black Line	This cable is working normally.
	Gray Line	This cable is not accessible.
	Red Dashed Line	This cable is experiencing degraded communication.
	Red X in Dotted Line	The connection between the nodes is broken.

These are examples of error situations when the application is running:

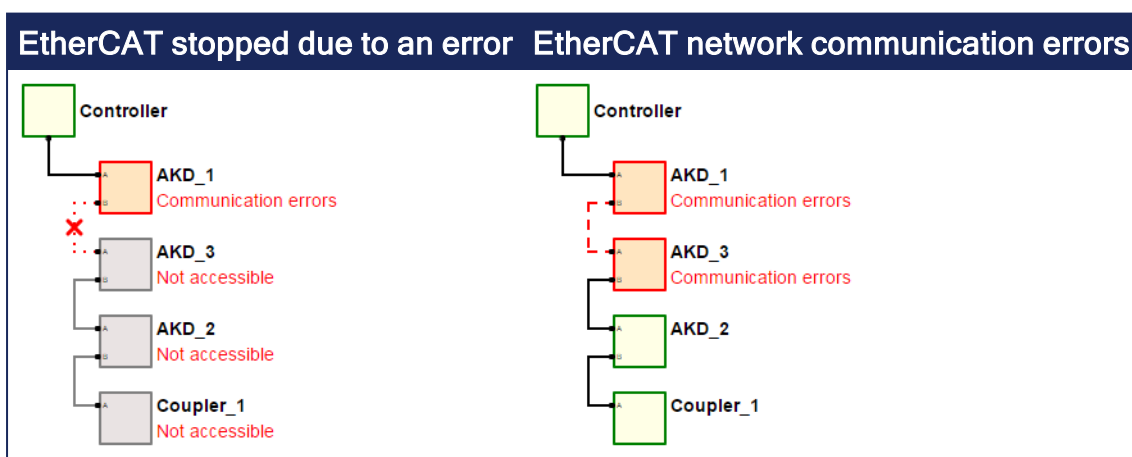

9 Tools

9.1 Cam Profile Editor

To open the cam profile editor in a new tab of the workspace, double-click a profile in the [Project Explorer](#).

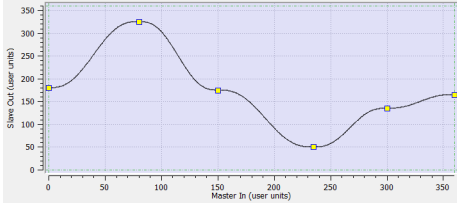

Figure 10-1: A cam profile

The cam profile editor is used to create and/or modify a profile definition that describes the position evolution of the cam.

- This evolution is displayed in a 2D graphical format.
- You can add, delete, or modify cam elements which consist of points and lines.
 - Based on those elements and some constraints, the KAS-IDE calculates a complete cam shape.
 - See "Cam Profile Segment Overview" (→ p. 451) for more information on the segment types.
- **Master/Input** (X-Axis) and **Slave/Output** (Y-axis) coordinates can be specified to define the position.
- It is also possible to visualize the velocity, acceleration, and jerk diagrams.

9.1.1 Windows Overview

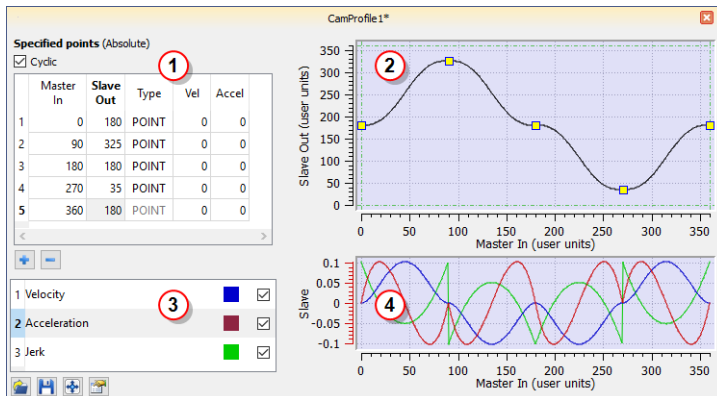

Figure 10-2: Cam Profile Editor Main Window

The cam profile editor contains these distinct areas separated by splitters:

1. The [cam table](#) (see call out 1) displays each element and allows editing of the cam.
2. The Graphical Area for the [cam profile](#) 2
The upper graph displays a graphical representation of the cam elements
3. The [Curve Selection and Color Table](#) 3 allows you to select which plots (velocity, acceleration and jerk) are displayed
4. The Graphical Area for [Curves](#) 4
The lower graph displays a graphical representation of the velocity, acceleration and jerk plots

TIP

Undo (Ctrl+Z) and Redo (Ctrl+Y) operations are available for any changes you make to the cam profile.

Splitters allow you to resize each part.

Improve your display with the splitters

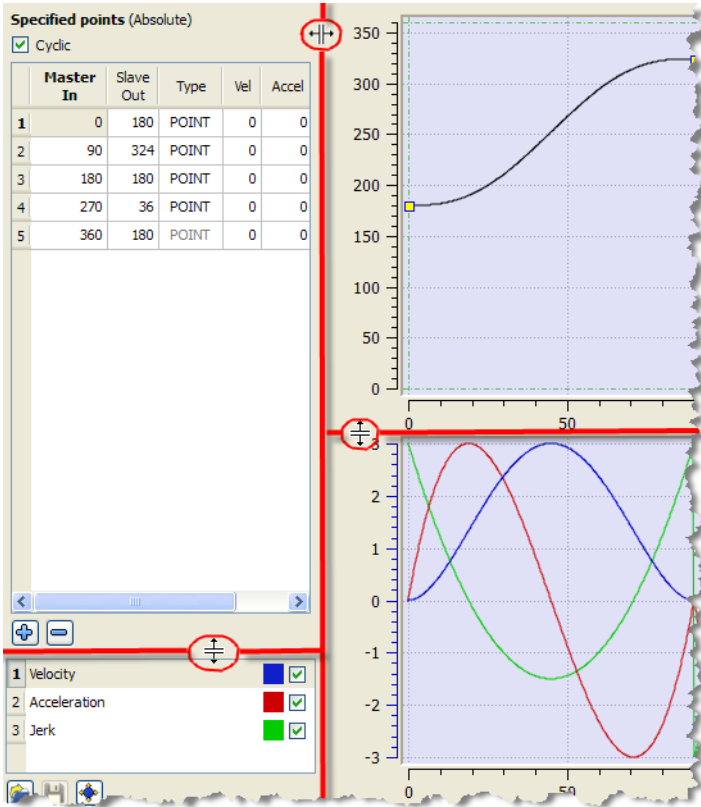

NOTE
The tables and the graphs are separated by a vertical splitter so that you can completely hide the tables to increase the graphical area.

See "Adding Cam Profiles" (→ p. 213) and "Profiles" (→ p. 76) for more information on cam profiles.

9.1.2 CAM Profile Editor's CAM Table

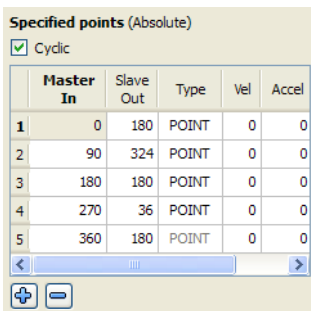

Figure 10-3: Cam Table

NOTE
By default, when a new profile is created, the CAM Profile contains five points. These points could be different from those in the image, depending on the offsets and amplitudes specified in the CAM Profile. See the "Create a CAM Profile" (→ p. 213) for more information.

9.1.2.1 Cam Editor - Table Parameters

Column	Description
Master/In	The time is located in the Master/In column. It is the X-axis of the cam profile graph.
Slave/Out	The position is located in the Slave/Out column. It is the Y-axis of the cam profile graph.
Type	The Type column defines whether this element is a point or a line. <ul style="list-style-type: none"> • If the element is a line, In/Out specifies the start point of the line. • The next element in the table defines the end of the line. • The last element type in the table cannot be changed, since a line cannot exist as the last element.
Vel	The Velocity of the current element (first derivative).
Accel	The Acceleration of the current element (second derivative).

9.1.2.2 Cyclic Cam Element

Specified points (Absolute)

Cyclic

If the **Cyclic** check box is selected, the cam profile is executed cyclically.

- This means that, when the axis attached to this cam runs continuously, the same profile is executed again.
 - In this case, the first and last element must have the same **Vel** and **Accel** values.
 - Changing the **Vel** or **Accel** value of the first or last elements automatically changes the other elements' value.

NOTE

When **Cyclic** is first turned on, the Vel/Accel values are automatically copied from the first element to the last element when they do not match.

A warning dialog opens indicating this change has happened.

This alert cannot be suppressed until KAS is closed.

There are some combinations of points and lines where **Cyclic** is automatically turned off.

If this occurs, the **Cyclic** checkbox label is changed to **Cyclic (automatically turned off)**.

These changes to the profile automatically turn off **Cyclic**:

- The first element has been changed from a point to a line.
 - If needed, **Cyclic** can be manually turned back on.
This will affect the velocity of the last element.
- The next to last element has been changed from a point to a line and now both first and next to last elements are lines.
 - **Cyclic** is disabled and can only be re-enabled when the first and next to last elements are not lines.
- The first element is a line and the first element is moved.
 - If needed, **Cyclic** can be manually turned back on.
This will affect the velocity of the last element.
- The first element is a line and the second element is moved.
 - If needed, **Cyclic** can be manually turned back on.
This will affect the velocity of the last element.
- The first element is a line and the last elements velocity (or slope line) has changed.
 - If needed, **Cyclic** can be manually turned back on.
This will change the velocity setting just made.

9.1.2.3 Modifying an Element using the Cam Table

You can modify a cam element by clicking in the **Master/Input**, **Slave/Output**, **Vel**, or **Accel** column and typing in a new value. For **Type**, refer to "Modifying the Type of a Cam Element" (→ p. 447).

The graphs are updated automatically when an element changes.

Some rules apply to the value entered:

- The **Master/Input** value must lie between adjacent **Master/Input** points
- The **Master/Input** value of the first and last point cannot change. These values are determined by the profile properties X offset and X amplitude
- The **Slave/Output** value must lie between the Y offset and Y amplitude set in the profile properties

If an entered value is invalid (due to the interpolation calculation), it is superseded with the original value without any error message.

About interpolation

The section between two consecutive cam elements is automatically calculated by a fifth order polynomial algorithm.

Modification of one cam element only affects the two adjacent segments.

9.1.2.4 Modifying the Type of a Cam Element

The type of element can either be a point or a line. The element type can be modified by double-clicking in the **Type** column of an element and then clicking on the down arrow. A list of choices is displayed as shown. Select the type of element from the list.

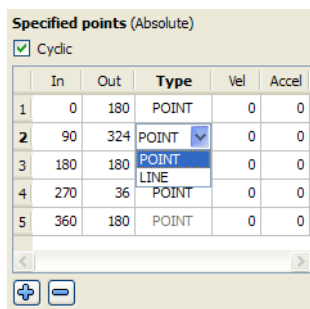

Figure 10-4: Modifying an Element Type

9.1.2.5 Cam Table Contextual Menu

Right-clicking on an entry in the cam table displays a contextual menu.

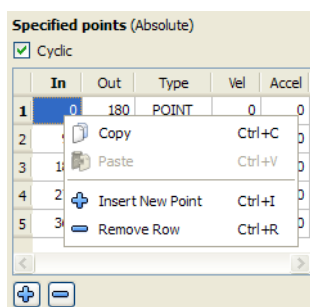



Figure 10-5: Cam Table Contextual Menu

Command	Shortcut	Description
Copy	Ctrl+C	Copy data from the selected cell in the clipboard
Paste	Ctrl+V	Paste the data from the clipboard into the selected cell

Command	Shortcut	Description
Insert New Point	Ctrl+I	Inserts a new row in the cam table above the highlighted entry. This command is described in "Add a Point to the Cam Table" (→ p. 448)
Remove Row	Ctrl+R	Deletes the row that contains the highlighted entry. This command is described in "Remove a Point from the Cam Table" (→ p. 449)

9.1.2.6 Add a Point to the Cam Table

You can add a point to the cam table using one of these methods:

- Use the menu in the cam table (shown in "Cam Table Contextual Menu" (→ p. 447)).
- Click the button  located below the cam table.
- Use the menu in the cam profile graph.

All of these methods open the **Add New Point** dialog box:

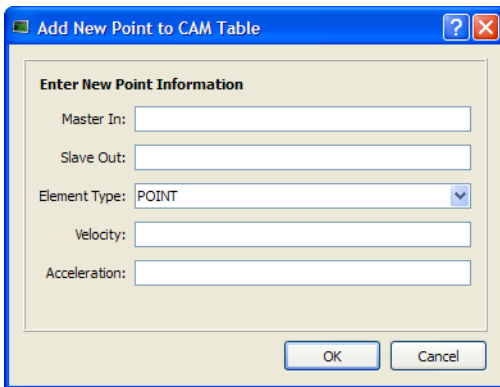

Figure 10-6: Add New Point

Field/Command	Description
Master In	The X value of the new point.
Slave Out	The Y value of the new point.
Element Type	POINT or LINE
Velocity	The velocity of the new point (first derivative).
Acceleration	The acceleration of the new point (second derivative).
OK	Accept the entry and verify if the point can be added.
Cancel	Cancel the dialog box – no point is added.

When you click OK, a check is performed to see if the point can be added to the cam profile.

If not, an error message opens.

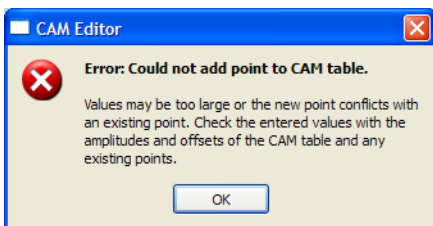

Figure 10-7: Cam Table Contextual Menu

If no problem is found, the point is added to the cam table and the graphical plots are updated.

NOTE

A new point cannot be inserted above the first element in the cam table.

9.1.2.7 Remove a Point from the Cam Table

You can remove a point from the cam table with one of the following methods:

- Use the menu in the cam table (shown in "Cam Table Contextual Menu" (→ p. 447))
- Click the button  located below the cam table
- Use the menu in the cam profile graph

The selected point is removed without prompting.

NOTE

The first and last points cannot be removed.

9.1.3 Cam Profile Graph

The upper graph displays the points and lines specified in the cam table along with the calculated curve. It also allows you to add, delete or modify a cam element.

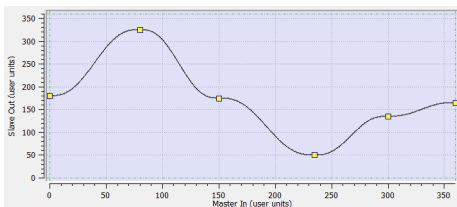



Figure 10-8: Cam Profile Graph

Points and endpoints of lines are displayed as yellow squares (■) in the graph. The profile offset and amplitude specified in the cam profile editor (see "Create a CAM Profile" on page 213) are displayed with a green dashed rectangle. The yellow squares are always contained within the green dashed rectangle (although calculated points can extend outside it).

9.1.3.1 Modifying an Element

You can modify the profile by moving point with the mouse as follows:

1. Move the mouse over a yellow square (the cursor becomes  indicating that the point can be selected)
2. Click to select the point and hold down the mouse button (left-click). When you move the mouse, the point follows the cursor (note that graphical curves and In/Out values are dynamically updated)

In addition, when a point is selected, a slope line is drawn over the point. This line is dashed purple with two additional grips (◆) attached to it. The slope line can be used to change the velocity of the selected point.

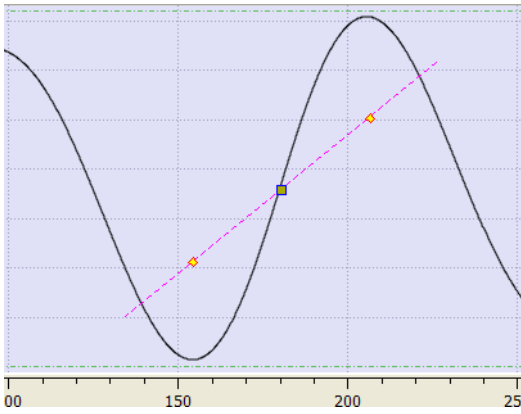



Figure 10-9: Cam Profile Graph - Slope Line

You can change the velocity of the selected point as follows:

1. Move the mouse over a slope grip (◆). The cursor changes to an open hand 
2. Click to select the grip and hold down the mouse. The cursor changes to a closed hand 
3. When you move the mouse, the slope line follows the cursor, rotating about the selected point and causing the velocity of the selected point to change. (Note that graphical curves and Vel value are dynamically updated)

9.1.3.2 Cam Profile Graph Contextual Menu

A right-click on the cam profile graph displays a contextual menu.

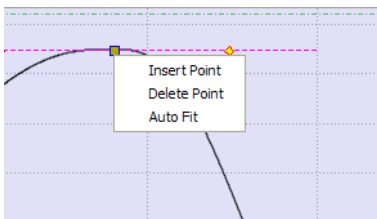

Figure 10-10: Cam Profile Graph - Contextual Menu

Command	Description
Insert Point	Inserts a new point at the X-Y location of the cursor
Delete Point	Deletes the highlighted point If the mouse is not near enough to a point, no point is highlighted and this command remains grayed-out
Auto Fit	Adjusts the zoom and pan settings so that the entire graph is displayed in the graphical area

9.1.3.3 Zoom In and Out

In the cam profile graph, you can zoom in or out as follows:

1. Move the cursor in the graphical area
2. Turn the mouse wheel forward or backward

The current cursor becomes the center point of the zoom function and the area under the cursor remains stationary on the graph.

9.1.3.4 Panning

In the cam profile graph, you can also pan (or move) in any direction as follows:

1. Click on any part of the graph (but not on a yellow square) and hold down the mouse button (left-click)
2. Move the mouse to move the graph accordingly

9.1.3.5 Restoring Zoom and Pan

To restore the zoom and pan settings, so the entire curve is displayed in the graphical area, click on the Auto Fit button  or select the Auto Fit command in the cam profile graph menu.

9.1.4 Cam Profile Segment Overview

- "Line Segment Type" (→ p. 451)
- "Parabolic Segment Type" (→ p. 451)
- "Point Segment Type" (→ p. 452)
- "Spline Segment Type" (→ p. 452)

9.1.4.1 Line Segment Type

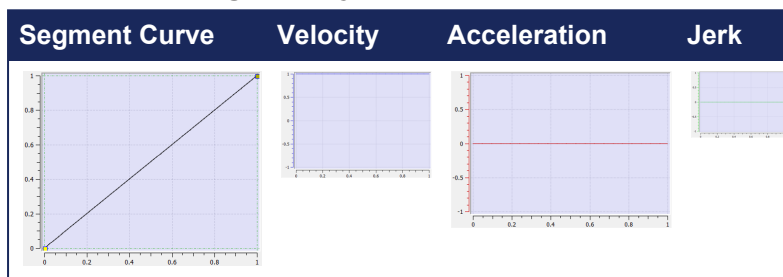

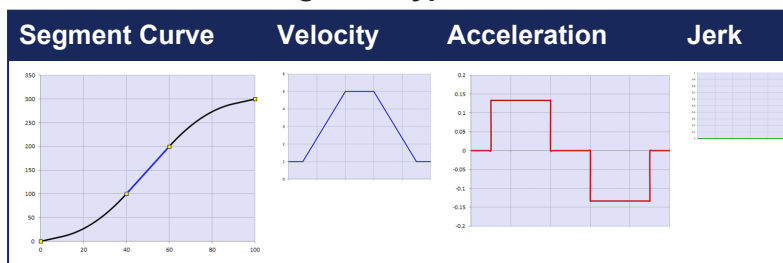

Supported by	KAS-IDE Profile Editor MLProfileBuild
Continuous Velocity	X
Continuous Acceleration	X
Interpolation Method	Linear function: $f(x) = Ax + B$
Advantages	This segment type easily defines constant-velocity segments. It can be used in very large numbers to define profiles of any size without having to specify the velocity or acceleration at the segment endpoints.
Disadvantages	Profiles can result in discontinuous velocities.

9.1.4.2 Parabolic Segment Type





In the example:

- The blue line represents the linear (constant velocity) part of the segment.
- The black lines represent the parabolic (constant acceleration) parts of the segment.

Supported by	KAS-IDE Profile Editor MLProfileBuild (parabolic option)
Continuous Velocity	
Continuous Acceleration	
Interpolation Method	Linear function: $f(x) = Ax + B$ 2 nd order polynomial: $f(x) = Cx^2 + Dx + E$
Advantages	This segment type is used to define constant acceleration portions of a profile. This minimizes the peak acceleration needed to move from one cam point to another. This can be useful when the motors cannot support the accelerations used by other segment types.
Disadvantages	Acceleration is discontinuous which can lead to additional electrical stress on the drives and motors.

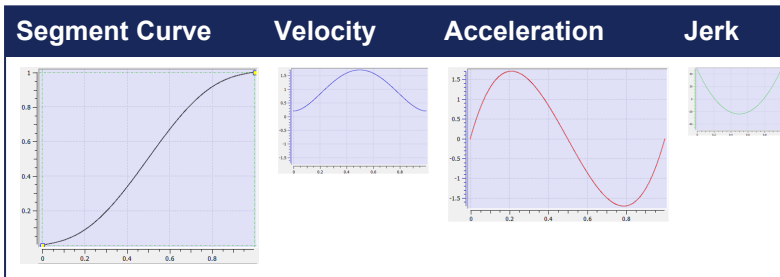
9.1.4.3 Point Segment Type



Supported by	KAS-IDE Profile Editor MLProfileBuild (default option)
Continuous Velocity	
Continuous Acceleration	
Interpolation Method	5 th order polynomial: $f(x) = Ax^5 + Bx^4 + Cx^3 + Dx^2 + Ex + F$
Advantages	With only a few segments, this type can be used to define profiles with continuously changing accelerations. Example: Sinusoidal profiles can be emulated with 6 to 12 point segments.
Disadvantages	Specify the velocity and acceleration at the endpoints for each segment. It is difficult to use the point segment type to define constant acceleration or constant velocity segments.

9.1.4.4 Spline Segment Type

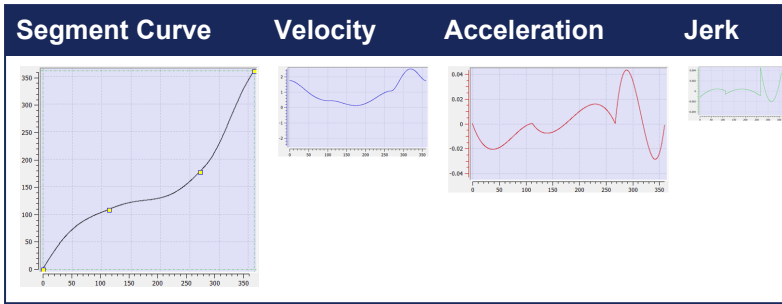

Supported by	KAS-IDE Profile Import. The points are created by separate software and is imported into KAS-IDE project.
Continuous Velocity	
Continuous Acceleration	
Interpolation Method	3 rd order polynomial: $f(x) = Ax^3 + Bx^2 + Cx + D$
Advantages	With only a few segments, this segment type can be used to define profiles with continuously changing velocities. Only the positions of the master and slave need to be specified. This produces smoother profiles than using line segments.
Disadvantages	Since only positions are specified, the user has less control over the velocities and accelerations that occur throughout the profile.

9.1.5 Curve Selection and Color Table

Velocity (first derivative), acceleration (second derivative) and jerk (third derivative) plots are displayed in the lower graph. If the element is a line, the velocity is constant and acceleration is 0.

With the check boxes in the Curve selection table shown in figure below, you can select or clear each individual curve to be displayed.

When a curve is selected (see blue highlighted row in figure below), the Y-scale of the Curves graph is adjusted to display the Y-scale of the selected curve. Also, the color of the 'tick' line of the scale is changed to match the color code of the selected curve.

1	Velocity		<input checked="" type="checkbox"/>
2	Acceleration		<input checked="" type="checkbox"/>
3	Jerk		<input checked="" type="checkbox"/>

Figure 10-11: Curve Selection Table

9.1.5.1 How to change color

You can change the color of a plot as follows:

1. Double-click on a colored square shown in the Curve Selection Table to open the color selection dialog box

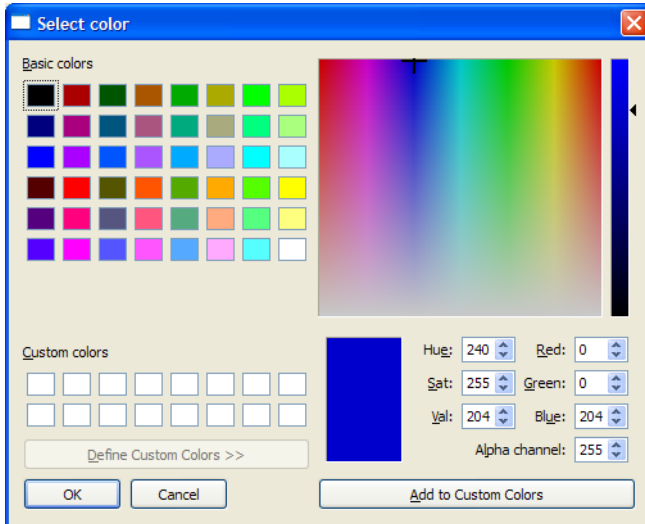

Figure 10-12: Standard Color Selection

2. Click on an existing color square to select it, or specify the numerical values for a color. (You can also move the black indicator on the right side until the desired color appears in the large colored rectangle)

9.1.5.2 Curves Graph

Velocity (the first derivative), acceleration (the second derivative) and jerk (the third derivative) curves are displayed in the lower graph. All plots are displayed by default.

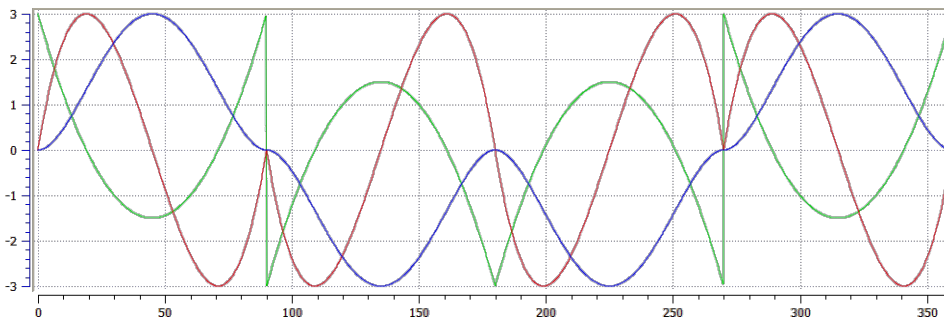

Figure 10-13: Curves Graph

With the check boxes in the Curve selection table shown in Figure: "**Curve Selection Table**", you can select or clear each individual curve that you want to be displayed.

The Y-scale of the Curves graph is adjusted to display the Y-scale of the selected curve in the Curve Selection Table. The color of the Y-axis scale "tick" lines is also changed to match the color code of the selected curve.

Y axis	Unit	Description
Vel	Units/Time	Being the rate of change of position, the velocity is the ratio between the slave and master derivatives
Accel	Units/Time ²	Rate of change of velocity with time
Jerk	Units/Time ³	Rate of change of acceleration; more precisely, the derivative of acceleration with respect to time





In general the numbers relate to how the Y-axis positions (Cam Output) change with respect to the X-axis positions (CAMinput).

The zoom and pan functions, when performed on the cam profile graph, are duplicated in the Curves graph. Zoom and pan functions are not available when the cursor is in the curves graph.

9.1.6 Reload, Save, Auto Fit, and Properties Buttons

These buttons are provided:

Cam Editor - List of Icons

Icon	Description
 Reload	Reload the saved profile. If unsaved changes have been made to the profile, a dialog box asks you to confirm that you want to discard the changes.
 Save	Save a modified profile.
 Autofit	Adjusts the zoom and pan settings so that the entire graph is displayed in the graphical area.
 Properties	Open the Cam Profile Properties dialog box to modify the Master/Input and Slave/Output Offset and Scale values.

9.1.7 Import a CAM Profile

The KAS-IDE can import CAM profiles from several sources:

- CAM profiles (.CAM file format) exported from another KAS project.
- User-defined CAM profiles (in .CSV format).
 - When imported, the .CSV file is converted to a .CAM file.

Row	Syntax
1	CYCLIC;YES;
2	TABLE_BEGIN;;
3	0;0;SPLINE
4	X;Y;SPLINE
:	X;Y;SPLINE
N	1000;1000;SPLINE
N+1	TABLE_END;;

Each row from 4 to N specifies the successive points that are part of the cam profile. The X and Y coordinates can be specified as floating-point values with sufficient digits after the decimal point (example: 995.2514255). To be valid, a CSV file must have **at least 4 spline segments** in it. See "Cam Profile Segment Overview" (→ p. 451) for more information on the segment types.

NOTE

Splines are the only segment type that is currently supported when importing CSV data into KAS-IDE. Other segment types are supported by importing and exporting .CAM files.

When a CSV file is imported the X, Y values are normalized with respect to maximum X, Y values present in the CSV file. The normalized X, Y values are scaled with respect to Master/Input scale and Slave/Output scale. They are added with Master/Input Offset and Slave /Output Offset respectively and will be displayed in the Specified points (Absolute) section of the cam profile.

Example:

CSV file X,Y Values:

```
0;0;SPLINE  
100;111;SPLINE  
200;222;SPLINE  
300;333;SPLINE
```

Max Value in CSV is

```
300;333;SPLINE
```

Normalized values:

```
0; 0;  
0.3333333333333333; 0.3333333333333333;  
0.6666666666666667; 0.6666666666666667;  
1;1;
```

Offset:

```
10    20
```

Scale:

```
300    360
```

Value displayed in profile:

```
10;20;  
109.99999999999999; 139.99999999999989;  
210.00000000000009; 260.00000000000011;  
310;380;
```

9.1.7.1 The Import

A quick validation is performed when the profile is first imported.

- The profile name is checked.
 - If it is in use, you are promoted to provide a new name.
- The data format is validated.
 - The profile is verified it can be compiled without error.

If cyclic is on, and the Vel/Accel values of the first element do not match the Vel/Accel of the last element, the first elements Vel/Accel are copied to the last elements. A warning message is posted to the log if this change takes place.

9.1.7.2 Displaying the Imported CAMProfile

When you display an imported profile, a dialog box indicates the progression of the import process.

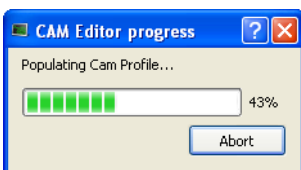

Click the **Abort** button to abort the process, then a default CAM profile is created.

9.1.7.3 Invalid Data

When you display a CAM profile where two points are too close, a dialog box indicates the error.

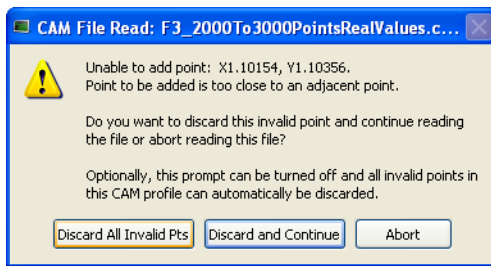

Click the **Discard All Invalid Pts** button to discard all additional invalid points found in this CAM profile.

A summary appears when the process is finished.

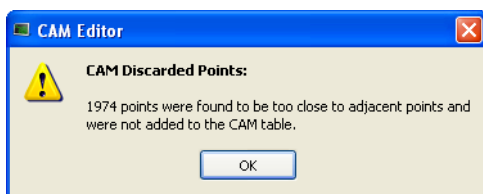

9.2 Custom Input/Output Editor

NOTE

This tool is reserved for Profibus fieldbuses only.

The Input/Output Editor (hereafter I/O Editor) is a tool used to declare and set up I/O devices, and establish the link between the application variables and physical equipment. It shows a list of the currently defined I/Os.

To open the I/O Editor select **Tools>Custom IO Editor** from the menubar.

Figure 10-14: Input/Output Editor

For the **Description** field, see [format explanations](#).

9.2.1 Add Input/Output

To add an I/O, drag-and-drop a variable from the dictionary to the I/O editor, then modify it.

9.2.2 Delete Input/Output

To delete an I/O:

1. Click somewhere on the I/O's row (or go to the row with the up/down arrow keys)
2. Press the delete key
3. Confirm the deletion.

9.2.3 Modify Input/Output

1. Double-click the cell to edit

TIP

You can also use the arrow keys to select the cell and press the **F2** key to start edition.

2. Set its driver name to the one of your choice, for example: **CIFDriver** (column 3)
3. Set its description to the corresponding driver address (column 4)

The **Description** field format has these characteristics:

1. It begins with a “%” character.
2. Followed by the type of I/O.

I: input, **Q**: Output

3. Followed by the size of I/O.

X: Boolean (1 bit), **B**: byte (8 bits), **W**: word (16 bits), **D**: double word (32 bits), **L**: long word (64 bits)

4. Followed by its address on the selected bus.

The address has the following format: “**deviceId.slaveId.moduleId.bitOffset**”, where **deviceId**, **slaveId**, **moduleId** and **bitOffset** are integers ranging from 0 to 65535.

NOTE

- set **deviceId** to 0
- set **slaveId** to the id of the I/O node
- set **moduleId** to the id of the slice
- **bitOffset** must always be 0 for non-Boolean I/Os

❗ IMPORTANT

The size of the variable and the I/O must be the same.

Example:

%IX0.1.2.4 is an input Boolean located on **deviceId=0**, **slaveId=1**, **moduleId=2** at **bitOffset=4**

%QB0.1.2.0 is an output byte located on **deviceId=0**, **slaveId=1**, **moduleId=2**

👉 TIP

If you enter invalid text, the table cell becomes red, and an explanation is also displayed in the **information** column.

See Also

also see "Map Input and Output to Variables" on page 314

9.3 Human-Machine Interface Editor

This section covers these tools you can use to design your HMI panels:

- The [Kollmorgen Visualization Builder](#) to control your application
- The [internal Control Panel editor](#) to debug your application with the KAS Simulator

9.3.1 Using Kollmorgen Visualization Builder



To work with Kollmorgen Visualization Builder:

1. Tag the PLC variables to export and map with the HMI (see "Map Variables to HMI" (→ p. 186) for more information).
2. Compile your project to generate the Modbus mapping file.
3. Create a KVB project ¹ in the KAS-IDE and open it.
4. "Design the HMI Panel with KVB" (→ p. 463).
5. Save and close KVB.

NOTE

Important! Be sure to use **Save** and not **Save As**.

The KVB is self-contained within the KAS archive and the Save As function moves the KVB out of the archive.

6. Save your KAS project.

NOTE

When you [create the KVB panel](#) with the KAS-IDE, all the creation and mapping procedure is done automatically after compiling your project.

You can directly go to "Design the HMI Panel with KVB" (→ p. 463).

ⓘ IMPORTANT

Be aware that as soon as you change the PLC variables exported for the HMI, the mapping file must be re-imported in Kollmorgen Visualization Builder to have an up-to-date version.

Related Documents

For further information on Kollmorgen Visualization Builder, see this documentation:

KVB Manuals	Description
Kollmorgen Visualization Builder™ Quick Start Guide	The Quick Start covers these important points to: <ul style="list-style-type: none"> • Install and use Kollmorgen Visualization Builder. • Configure HMI Panels and PC operated control applications.
Kollmorgen Visualization Builder™ User Manual	Contains all the content to help with Kollmorgen Visualization Builder.

9.3.1.1 Create A New KVB Controller

This procedure is applicable when you use Kollmorgen Visualization Builder externally.

- After choosing to create a new project, select the type of operator panel to be used

¹There is no built-in feature to import/export KVB projects.

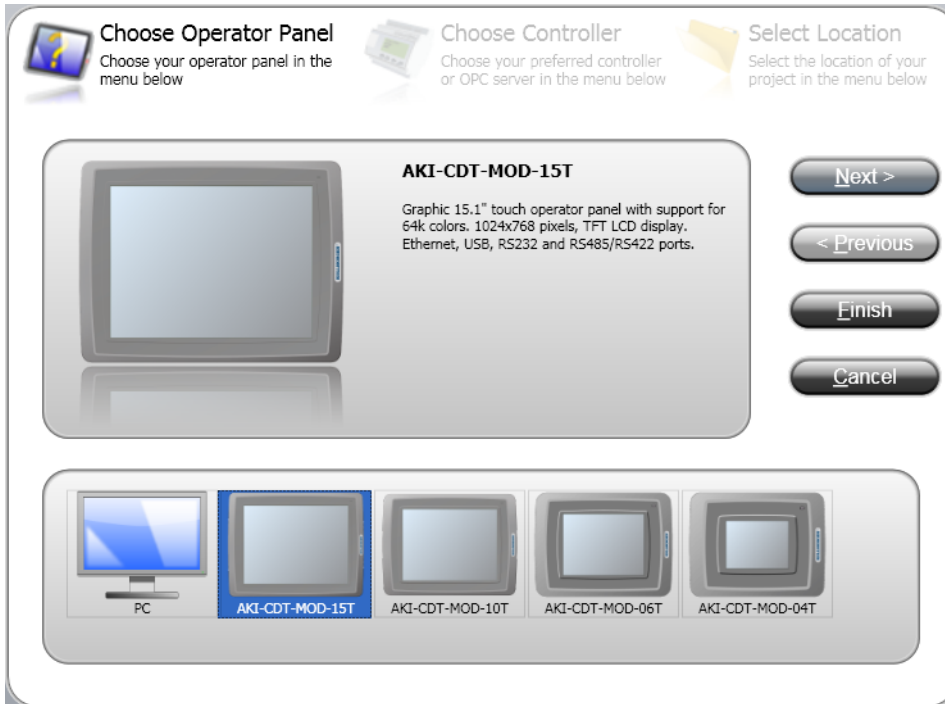

- On the next dialog, select the **Kollmorgen** controller with the Modbus protocol, then click the **Next** button

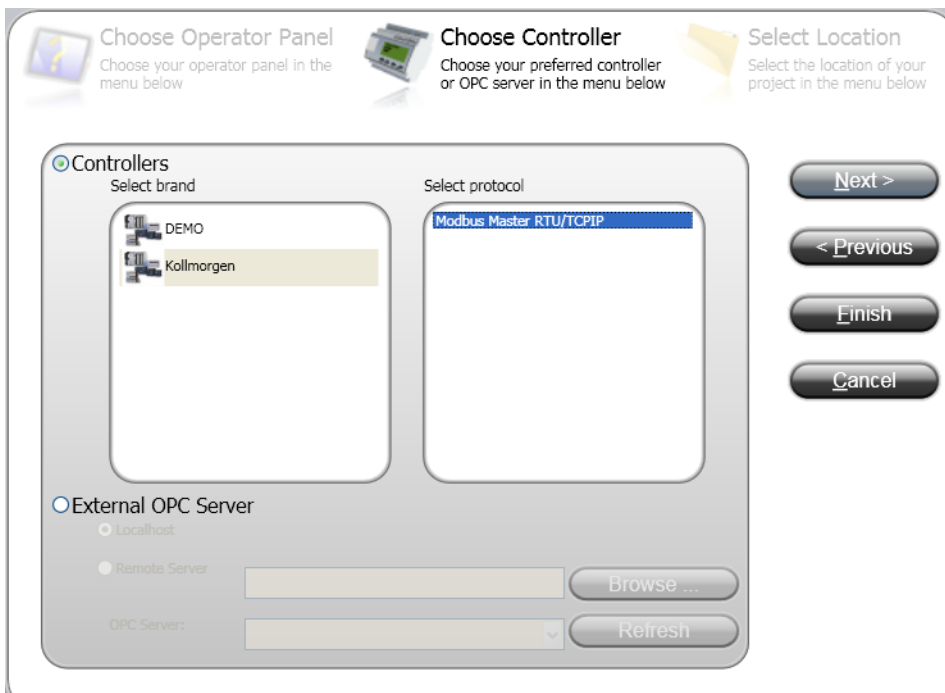

- Enter the name of the project and where you want to create the project. Then click the **Finish** button

The screenshot shows a dialog box titled 'Choose Target' with three tabs: 'Choose Target', 'Choose Controller', and 'Select Location'. The 'Choose Target' tab is selected. Below the tabs, there are three instructions: 'Choose your target in the menu below', 'Choose your preferred controller or OPC server in the menu below', and 'Select the location of your project in the menu below'. The 'Name:' field contains 'MyBigProject' and the 'Location:' field contains 'C:\Users\William.Gaffga\Documents\Kollmorgen Projects'. A 'Browse...' button is next to the location field. On the right side, there are four buttons: 'Next >', '< Previous', 'Finish', and 'Cancel'.

9.3.1.2 Import Variables Into The Project

When you open the Kollmorgen Visualization Builder with your KVB panel (by double-clicking the KVB panel from the [project explorer](#)) all the variables tagged into the [Dictionary](#) at the time of compiling are automatically imported into Kollmorgen Visualization Builder. Once the file is imported, all PLC variables are available for use within Kollmorgen Visualization Builder.

TIP

To reimport variables, (if they were changed or more were added), simply ensure they are tagged as "KVB" in the Variables list, recompile your KAS project, and open the KVB from the KAS-IDE.

1. Select **Others** to display the Action column
2. You can edit the tag actions

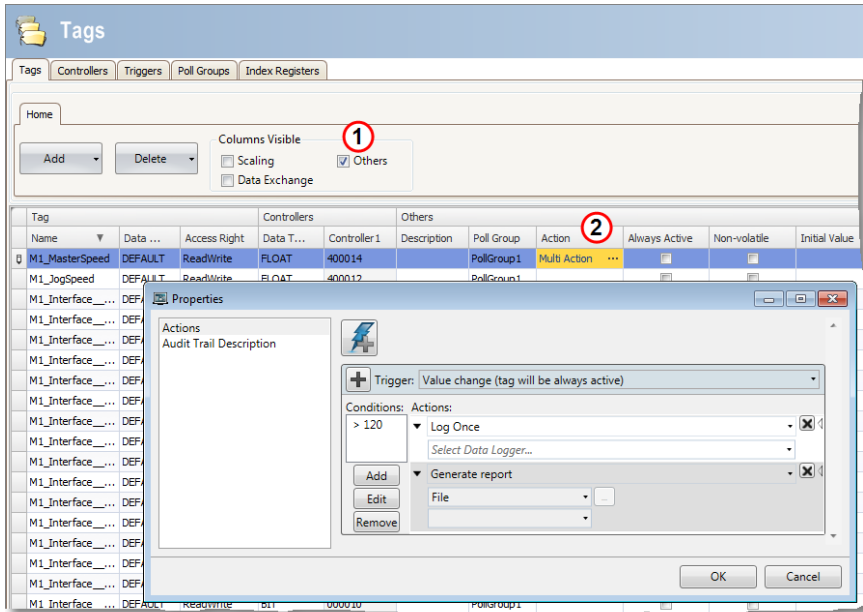

To manually export/import the variables (tags) of your project use the import procedure as follows:

- Select the **Tags** tab
- Click the arrow of the **Import** button, then select **Import tags to [Controller1]...** in the drop-down menu

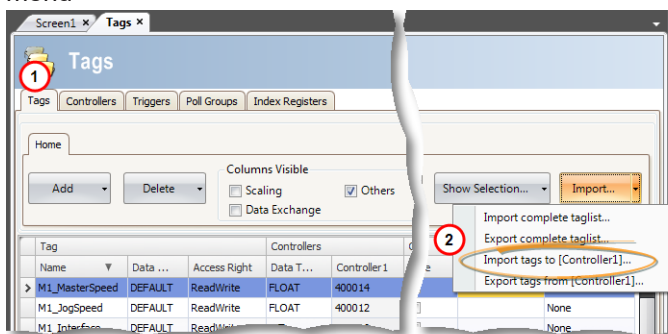

- In the import dialog, specify the filename by clicking the ... button

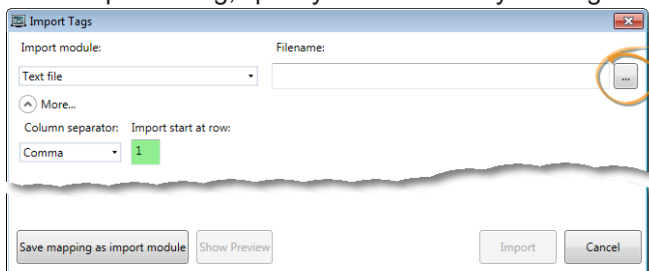

- Then use the open file dialog to find the **.txt** file
- Once the file is specified, click the **Open** button

- Back in the import dialog, make sure the **Column separator** is set for Comma, and leave all options selected, then click the **Import** button

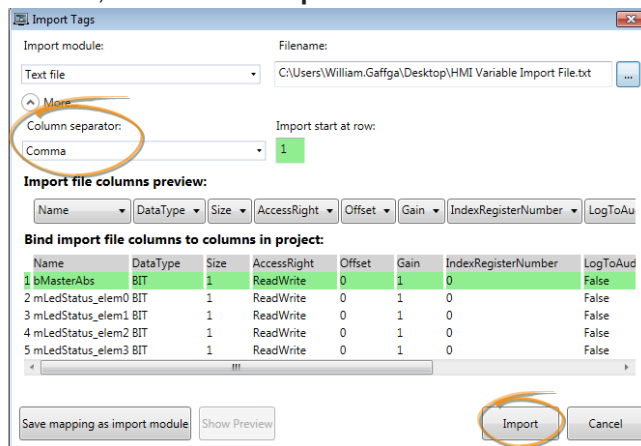

- Specify which tags (variables) you want to import. To select all tags, click the **Select All** option. When you have finished selecting the tags, click the **OK** button

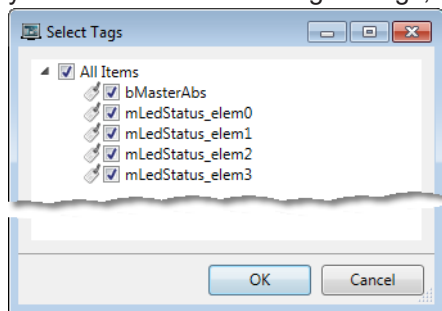

- You are notified of how many items are successfully imported. Click the **OK** button to return to the project.

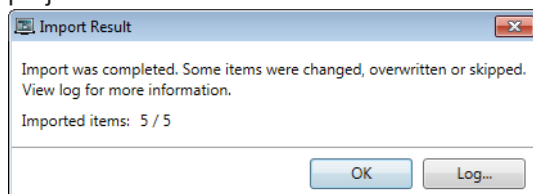

9.3.1.3 Design the HMI Panel with KVB

ⓘ IMPORTANT

Do not modify **Project Name** and **Title** to keep consistency between Kollmorgen Visualization Builder (KVB) and the KAS-IDE.

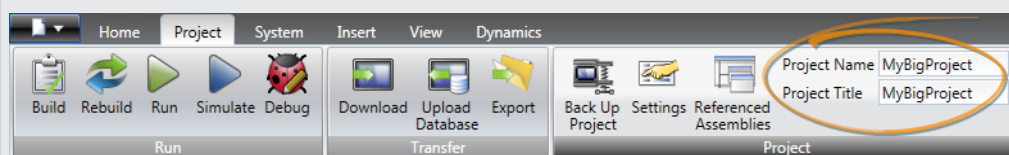

9.3.1.3.1 Add Object

You can drag-and-drop predefined objects from the library to the screen. The library is located in the **Home** tab of Kollmorgen Visualization Builder.

9.3.1.3.2 Customize Object

Select an object and click the **General** tab to customize:

- its settings in the Settings section
- its style to a different template in the Style section

9.3.1.3.3 Map Variable to the Object

In the **General** tab, you can set the Variable or Tag that maps to the current object in the Tag/Security section.

NOTE

Click the **F1** key to open the Kollmorgen Visualization Builder online help (or use the Help button in the ribbon tab heading)

ⓘ IMPORTANT

Be aware that as soon as you change the PLC variables exported for the HMI, the mapping file must be re-imported in Kollmorgen Visualization Builder to have an up-to-date version.

9.3.1.4 Download the KVB Panel

To download your panel you have to use the Project ribbon in Kollmorgen Visualization Builder that contains the **Transfer** command. To download, you must be connected directly to the HMI panel through an Ethernet cable.

The IP address is already defined (for more details, click here...) so nothing special has to be done before transferring your panel to the graphic operator terminal.

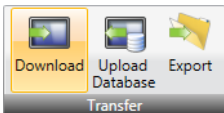

Button	Description
Download	The Download control sends the project to an HMI-panel, or a controller with a Kollmorgen Visualizer RT installation, in the network environment.
Upload Database	The Upload Database command collects the database from an HMI-panel in the network environment to a file on the development PC. The panel pauses during the upload and is started automatically afterwards.
Export	The Export command builds and exports a copy of the project. All needed files to transfer the project to another location.

NOTE

- If you transfer your project on a USB stick, place it in the USB port of the AKI panel while it is booting up.
- For more details, see the online help in Kollmorgen Visualization Builder.

9.3.2 Design the HMI with the Internal Editor

This section details the Controls and Properties used to:

- Define the Control Panel to debug the application.
- "Map Variables to the Control Panel" (→ p. 466).

9.3.2.1 Create Control Panel

Control Panel are managed in the Project Explorer and can be created as follows:

1. In the Project Explorer, right-click the Controller item to open the menu
2. Select the **New Control Panel** command
3. Right-click on the newly created item and select the **Rename** command to change its name
4. Double-click the new Control Panel to open it in the graphical editor

9.3.2.2 Use the Control Panel Control Library

- Select a control in the Libraries toolbox (Controls tab) and drag-and-drop it in your Control Panel.

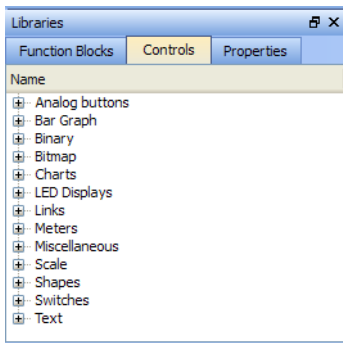

Figure 10-15: Control Panel Control Library

For a list of controls, see "Graphic Objects" (→ p. 467).

9.3.2.3 Edit the Control panel

When a control is selected, you can change its properties (displayed in the Libraries toolbox) by double-clicking the **Value**.

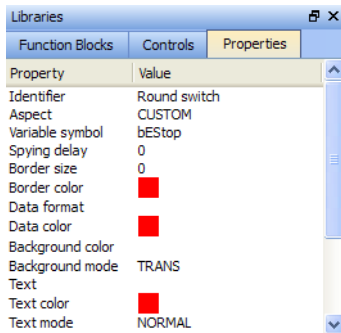

Figure 10-16: Control Panel Control Properties

For an exhaustive list of properties, refer to (→ # 474, Graphic Objects Properties)

NOTE

- You can perform multi-selection with the mouse (all the controls that are even partly inside the selection area are selected)
- You can add controls to your selection either with the **Ctrl** or **Shift** keys
- You can use Arrow keys to move the Control Panel page Up, Down and sideways.
- You can use Shift + Arrow keys to move the selected Control up-down and sideways

TIP

To duplicate all the selection, hold down **Ctrl** and click the right mouse button while performing your move operation (do not forget to release the mouse button first, before the **Ctrl** key).



Figure 10-17: Control Panel - Selection of Controls

9.3.2.3.1 HMI Grid Settings

Right-clicking in the Control Panel's graphical editor provides access to the Grid Settings by selecting Grid. This may also be accessed by pressing Ctrl-G. The settings allow you to control the appearance of the grid as well as forcing objects to "snap" to the grid. Settings are per panel and are saved with the project.

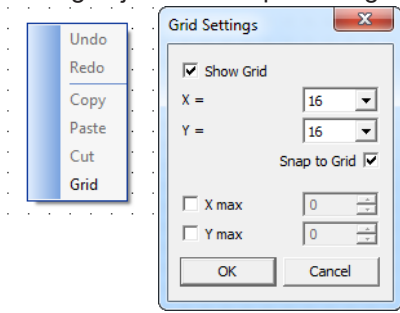

Parameter	Description
Show Grid	Display or hide the grid in the Control Panel
X= / Y=	Space between each grid dot in X/Y directions
Snap to Grid	Controls will be forcibly aligned with the grid when they are placed/moved
X max / Y max	Set a maximum area in which the grid is shown. The editor is grayed out beyond these dimensions. Please note that objects may still be placed within the grayed out area as it is merely a visual aid.

9.3.2.4 Map Variables to the Control Panel

How do I define a variable for PLC programs?

To link your Control panel with the PLC programs, some controls contain a property called **Variable symbol**

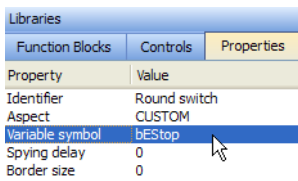

Figure 10-18: Map variables to a Control Panel control

To map the variable:

1. Select the variable in the Dictionary toolbox

2. Move it to the control to be linked in the Control panel editor using drag-and-drop

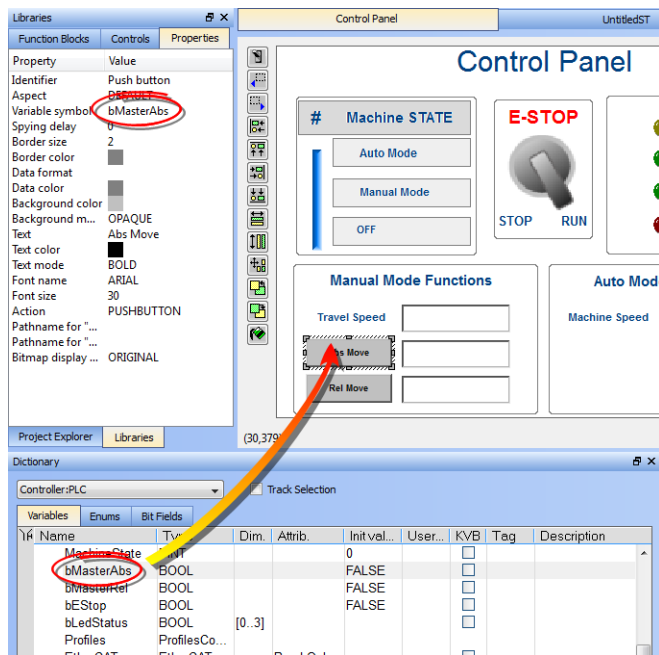

Figure 10-19: Map Variables to a Control Panel Control in the Graphical Editor

The Variable symbol is automatically updated in the **Properties** tab.

NOTE

A warning will be generated when the program is compiled if the control is mapped to a variable which is not in the Dictionary. Double-clicking the warning will highlight the control object and open the editor so the variable can be defined.

9.3.2.5 Graphic Objects

These are the available basic objects you can insert in your graphics:

9.3.2.5.1 Basic Shapes



A collection of basic drawings is available. Each object can be either static, or linked to a variable used to enable its visibility (show/hide).

Properties

- "Aspect (shapes)" (→ p. 475)
- "Background color" (→ p. 476)
- "Background mode" (→ p. 476)
- "Border color" (→ p. 477)
- "Border size" (→ p. 477)
- "Color when not connected" (→ p. 477)
- "Data format" (→ p. 477)
- "Direction (basic shapes)" (→ p. 477)
- "FALSE color" (→ p. 478)
- "Font name" (→ p. 478)
- "Font size" (→ p. 478)
- "Identifier" (→ p. 478)
- "Spying delay" (→ p. 478)

- "Text" (→ p. 478)
- "Text color" (→ p. 478)
- "Text mode" (→ p. 479)
- "TRUE color" (→ p. 479)
- "Variable symbol" (→ p. 479)

9.3.2.5.2 Bitmaps

Bitmap file (BMP, GIF, JPG) can be inserted in the graphic area.

Properties:

- "Background color" (→ p. 476)
- "Background mode" (→ p. 476)
- "Bitmap display mode" (→ p. 476)
- "Bitmap pathname" (→ p. 477)
- "Border color" (→ p. 477)
- "Border size" (→ p. 477)
- "Border style" (→ p. 477)
- "Font name" (→ p. 478)
- "Font size" (→ p. 478)
- "Identifier" (→ p. 478)
- "Text" (→ p. 478)
- "Text color" (→ p. 478)
- "Text mode" (→ p. 479)

NOTE

Large bitmaps are time-consuming during animation and can lead to poor performance, mainly if they have the "STRETCH" display mode or the "TRANS" (transparent) background mode.

TIP

Graphics need to be made portable with a project, otherwise the KAS-IDE attempts to point to the original location of the graphic files.

To make graphics portable, copy them to

C:\Users\[user folder]\AppData\Local\Kollmorgen\Project\Controller\PLC.

After this the graphics are a part of the .KAS file.

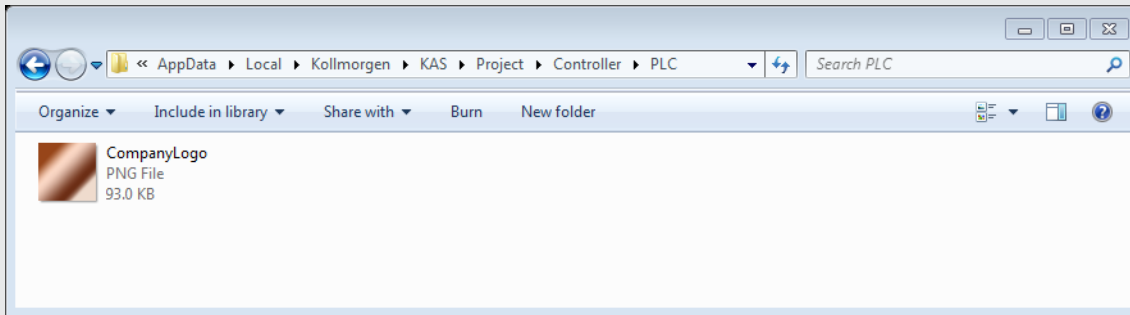

9.3.2.5.3 Scales

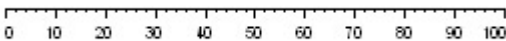

Scales are static drawings representing an X or Y axis, generally used to document other objects such as trend charts or bargraphs.

Properties:

- "Background color" (→ p. 476)
- "Background mode" (→ p. 476)
- "Border color" (→ p. 477)

- "Border size" (→ p. 477)
- "Border style" (→ p. 477)
- "Color when not connected" (→ p. 477)
- "Direction (scale)" (→ p. 478)
- "Font name" (→ p. 478)
- "Font size" (→ p. 478)
- "Identifier" (→ p. 478)
- "Maximum value" (→ p. 478)
- "Minimum value" (→ p. 478)
- "Nb divisions (main)" (→ p. 478)
- "Nb divisions (small)" (→ p. 478)
- "Placement (scale)" (→ p. 478)
- "Scale color" (→ p. 478)
- "Text" (→ p. 478)
- "Text color" (→ p. 478)
- "Text mode" (→ p. 479)

9.3.2.5.4 Text boxes



Static, animated or edit text boxes are available for displaying / forcing variables. For edit boxes at runtime, double-click on the object to enter the value and then hit ENTER to validate the input.

Properties:

- "Action (text)" (→ p. 475)
- "Background color" (→ p. 476)
- "Background mode" (→ p. 476)
- "Border color" (→ p. 477)
- "Border size" (→ p. 477)
- "Border style" (→ p. 477)
- "Data format" (→ p. 477)
- "Font name" (→ p. 478)
- "Font size" (→ p. 478)
- "Identifier" (→ p. 478)
- "Spying delay" (→ p. 478)
- "Text" (→ p. 478)
- "Text color" (→ p. 478)
- "Text mode" (→ p. 479)
- "Variable symbol" (→ p. 479)

9.3.2.5.5 Switches and 2-state displays



Buttons, switches and 2-state displays are used for control or display of a Boolean variable.

Properties:

- "Action (switch)" (→ p. 475)
- "Aspect (switches)" (→ p. 476)
- "Background color" (→ p. 476)
- "Background mode" (→ p. 476)
- "Bitmap display mode" (→ p. 476)
- "Bitmap for "FALSE" state" (→ p. 476)
- "Bitmap for "TRUE" state" (→ p. 476)

- "Border color" (→ p. 477)
- "Border size" (→ p. 477)
- "Data color" (→ p. 477)
- "Data format" (→ p. 477)
- "Font name" (→ p. 478)
- "Font size" (→ p. 478)
- "Identifier" (→ p. 478)
- "Spying delay" (→ p. 478)
- "Text" (→ p. 478)
- "Text color" (→ p. 478)
- "Text mode" (→ p. 479)
- "Variable symbol" (→ p. 479)

9.3.2.5.6 Analog buttons

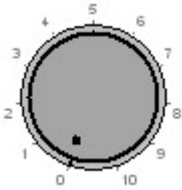

Analog buttons are used for setting the value of an integer or real variable. The mouse is used for setting the value.

Properties:

- "Background color" (→ p. 476)
- "Background mode" (→ p. 476)
- "Border color" (→ p. 477)
- "Border size" (→ p. 477)
- "Border style" (→ p. 477)
- "Data color" (→ p. 477)
- "Data format" (→ p. 477)
- "Font name" (→ p. 478)
- "Font size" (→ p. 478)
- "Identifier" (→ p. 478)
- "Maximum value" (→ p. 478)
- "Minimum value" (→ p. 478)
- "Scale color" (→ p. 478)
- "Spying delay" (→ p. 478)
- "Text" (→ p. 478)
- "Text color" (→ p. 478)
- "Text mode" (→ p. 479)
- "Variable symbol" (→ p. 479)

9.3.2.5.7 Bar Graphs



Bargraphs are rectangles filled according to the value of an analog variable. Bargraphs can be horizontal or vertical.

Properties:

- "Background color" (→ p. 476)
- "Background mode" (→ p. 476)
- "Border color" (→ p. 477)
- "Border size" (→ p. 477)
- "Border style" (→ p. 477)

- "Data color" (→ p. 477)
- "Data format" (→ p. 477)
- "Direction (bar graph)" (→ p. 477)
- "Font name" (→ p. 478)
- "Font size" (→ p. 478)
- "Identifier" (→ p. 478)
- "Maximum value" (→ p. 478)
- "Minimum value" (→ p. 478)
- "Spying delay" (→ p. 478)
- "Text" (→ p. 478)
- "Text color" (→ p. 478)
- "Text mode" (→ p. 479)
- "Variable symbol" (→ p. 479)

9.3.2.5.8 Charts

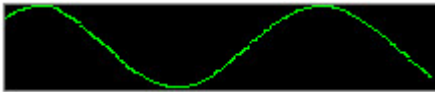

Charts enable the tracing of a variable as with an oscilloscope.

Properties:

- "Aspect (trend charts)" (→ p. 476)
- "Background color" (→ p. 476)
- "Background mode" (→ p. 476)
- "Border color" (→ p. 477)
- "Border size" (→ p. 477)
- "Border style" (→ p. 477)
- "Data color" (→ p. 477)
- "Data format" (→ p. 477)
- "Font name" (→ p. 478)
- "Font size" (→ p. 478)
- "Identifier" (→ p. 478)
- "Maximum value" (→ p. 478)
- "Minimum value" (→ p. 478)
- "Nb of points (trends)" (→ p. 478)
- "Spying delay" (→ p. 478)
- "Text" (→ p. 478)
- "Text color" (→ p. 478)
- "Text mode" (→ p. 479)
- "Variable symbol" (→ p. 479)

9.3.2.5.9 Analog meters

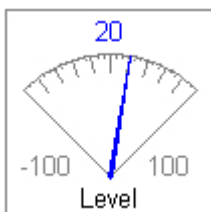

Analog meters provide a graphical display of an analog value.

Properties:

- "Background color" (→ p. 476)
- "Background mode" (→ p. 476)
- "Border color" (→ p. 477)
- "Border size" (→ p. 477)

- "Border style" (→ p. 477)
- "Data color" (→ p. 477)
- "Data format" (→ p. 477)
- "Font name" (→ p. 478)
- "Font size" (→ p. 478)
- "Identifier" (→ p. 478)
- "Link" (→ p. 478)
- "Maximum value" (→ p. 478)
- "Minimum value" (→ p. 478)
- "Nb divisions (main)" (→ p. 478)
- "Nb divisions (small)" (→ p. 478)
- "Scale color" (→ p. 478)
- "Spying delay" (→ p. 478)
- "Text" (→ p. 478)
- "Text color" (→ p. 478)
- "Text mode" (→ p. 479)
- "Variable symbol" (→ p. 479)

Sliders



Sliders are used for entering an analog value with a horizontal or vertical mouse driven cursor.

Properties:

- "Background color" (→ p. 476)
- "Background mode" (→ p. 476)
- "Border color" (→ p. 477)
- "Border size" (→ p. 477)
- "Border style" (→ p. 477)
- "Data color" (→ p. 477)
- "Data format" (→ p. 477)
- "Direction (slider)" (→ p. 478)
- "Font name" (→ p. 478)
- "Font size" (→ p. 478)
- "Identifier" (→ p. 478)
- "Maximum value" (→ p. 478)
- "Minimum value" (→ p. 478)
- "Scale color" (→ p. 478)
- "Spying delay" (→ p. 478)
- "Text" (→ p. 478)
- "Text color" (→ p. 478)
- "Text mode" (→ p. 479)
- "Variable symbol" (→ p. 479)

9.3.2.5.10 Digital meters



Digital meters (digits) display the value of a variable with the same aspect as a digital clock.

Properties:

- "Aspect (digits)" (→ p. 475)
- "Background color" (→ p. 476)
- "Background mode" (→ p. 476)
- "Border color" (→ p. 477)

- "Border size" (→ p. 477)
- "Border style" (→ p. 477)
- "Data color" (→ p. 477)
- "Data format" (→ p. 477)
- "Font name" (→ p. 478)
- "Font size" (→ p. 478)
- "Identifier" (→ p. 478)
- "Maximum value" (→ p. 478)
- "Minimum value" (→ p. 478)
- "Spying delay" (→ p. 478)
- "Text" (→ p. 478)
- "Text color" (→ p. 478)
- "Text mode" (→ p. 479)
- "Variable symbol" (→ p. 479)

9.3.2.5.11 Links

[Back to main page](#)

Links are mouse-driven hyperlinks that are used as shortcuts to open another graphic document. Using links enables the design of multi-page animated applications.

Properties:

- "Background color" (→ p. 476)
- "Background mode" (→ p. 476)
- "Border color" (→ p. 477)
- "Border size" (→ p. 477)
- "Border style" (→ p. 477)
- "Font name" (→ p. 478)
- "Font size" (→ p. 478)
- "Identifier" (→ p. 478)
- "Link" (→ p. 478)
- "Text" (→ p. 478)
- "Text color" (→ p. 478)
- "Text mode" (→ p. 479)

9.3.2.5.12 Connection status

Connection status is a box actuated with the current status of the connection and the connected runtime application. It is mainly dedicated to diagnostic.

Properties:

- "Background color" (→ p. 476)
- "Background mode" (→ p. 476)
- "Border color" (→ p. 477)
- "Border size" (→ p. 477)
- "Border style" (→ p. 477)
- "Data color" (→ p. 477)
- "Data format" (→ p. 477)
- "Font name" (→ p. 478)
- "Font size" (→ p. 478)
- "Identifier" (→ p. 478)
- "Spying delay" (→ p. 478)
- "Text" (→ p. 478)
- "Text color" (→ p. 478)
- "Text mode" (→ p. 479)

9.3.2.5.13 Gauges

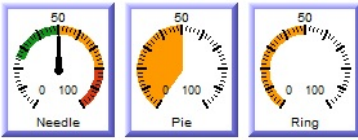

Analog view meter.

Properties:

- "Background color" (→ p. 476)
- "Background mode" (→ p. 476)
- "Border color" (→ p. 477)
- "Border size" (→ p. 477)
- "Border style" (→ p. 477)
- "Data color" (→ p. 477)
- "Data format" (→ p. 477)
- "Font name" (→ p. 478)
- "Font size" (→ p. 478)
- "Identifier" (→ p. 478)
- "Maximum value" (→ p. 478)
- "Minimum value" (→ p. 478)
- "Nb divisions (main)" (→ p. 478)
- "Nb divisions (small)" (→ p. 478)
- "Needle color" (→ p. 478)
- "Spying delay" (→ p. 478)
- "Title" (→ p. 479)
- "Title color" (→ p. 479)
- "Title placement" (→ p. 479)
- "Variable symbol" (→ p. 479)

Other Properties:

- Needle aspect: defines how the dynamic area must be shown (see bitmaps)
- Background bitmap: optional bitmap to be displayed as background
- Needle X/Y position: start position from the center of the image (percents)
- Needle size: needle with (percents)
- Needle angle: angles for min/max values in degrees
- Green color: color for the "low" range
- Green to: maximum "low" value
- Yellow color: color for the "medium" range
- Yellow to: maximum "medium value"
- Red color: color for the "high" range
- Red to: maximum "high" value
- Value placement: where the text value should be drawn
- Set Gain/offset

9.3.2.6 Graphic Objects Properties

This page details all possible properties for graphic objects. Refer to the [list of available objects](#) for further information on which property is used for which object.

TIP

Double-click an object to open the **Graphic Item Properties** dialog box.

This dialog lists the properties particular to that object.

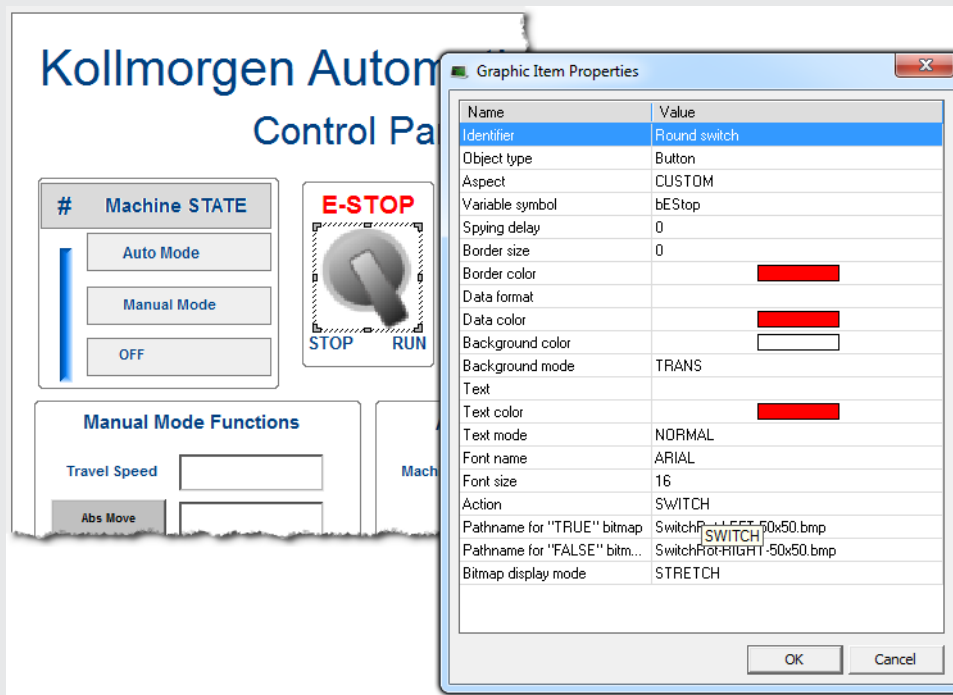

Name	Description
Action (switch)	Indicates the possible mouse action for switches. Possible values are: <ul style="list-style-type: none"> • STATIC = no mouse action. • PUSHBUTTON = the variable is forced to TRUE when pressed and FALSE when released. • SWITCH = the status of the variable is inverted when the button is pressed. • ONESHOTBUTTON = same as switch, but the display continues to appear released.
Action (text)	Indicates the possible mouse actions for text boxes. Possible values are: <ul style="list-style-type: none"> • STATIC = no mouse action. • EDIT = double-click opens an edit box for entering the variable value.
Aspect (digits)	Indicates the type of drawing for a digital meter. Possible aspects are: <ul style="list-style-type: none"> • DEFAULT = plain drawing. • BEZEL = all segments have a 3D effect.
Aspect (shapes)	Indicates the type of basic shape to be drawn. Possible aspects are: <ul style="list-style-type: none"> • CYLINDER = a 3D like cylinder. • ELLIPSE = an ellipse. • GATE = a simple vector drawing for a valve. • HALFELLIPSE = one half of an ellipse. • RECTANGLE = a rectangle. • ROUNDRECT = a rectangle with rounded corners. • TRIANGLE = a triangle

Name	Description
Aspect (switches)	<p>Indicates the type of switch to be drawn.</p> <p>Possible aspects are:</p> <ul style="list-style-type: none"> • DEFAULT = a standard Windows-like push button. • CUSTOM = a button with TRUE and FALSE drawings defined with bitmaps.
Aspect (trend charts)	<p>This property indicates the type of drawing for a trend chart.</p> <p>Possible aspects are:</p> <ul style="list-style-type: none"> • POINT = only relevant dots are drawn. • LINE = lines are drawn from point to point. • HISTO = histogram style.
Background color	<p>Indicates the color used for filling the background of the object.</p> <p>In case of a bitmap, it specifies the color that must not be drawn if the TRANS (transparent) background mode is specified.</p>
Background mode	<p>Indicates whether the background of the object must be filled or not.</p> <ul style="list-style-type: none"> • If this property is: <ul style="list-style-type: none"> • OPAQUE, the background is filled with the specified background color. • TRANS (transparent), the background is not filled. <ul style="list-style-type: none"> • Transparent drawing mode can be useful in the case of overlapping objects. <p>⚠ IMPORTANT</p> <p>Specifying the TRANS (transparent) mode for large bitmaps is time-consuming and affects the real-time performances of graphic updates.</p>
Bitmap display mode	<p>For bitmap-based objects, this indicates whether the attached bitmap must keep its original aspect or be stretched to the actual size of the object.</p> <p>Possible values are:</p> <ul style="list-style-type: none"> • ORIGINAL = keep the original aspect of the bitmap (cut if too large). • STRETCH = stretch or shrink the bitmap for fitting the actual size of the graphic object. <p>⚠ IMPORTANT</p> <p>Large bitmaps with STRETCH display mode are time-consuming during animation and can lead to poor performance.</p>
Bitmap for "FALSE" state	<p>For two-state objects with the CUSTOM aspect, this specifies the pathname of the bitmap to display when the value of the attached variable is FALSE (or zero for analogs).</p> <ul style="list-style-type: none"> • BMP, GIF, and JPG formats are supported. • If no directory is specified, the specified file name is searched: <ul style="list-style-type: none"> • in the project folder. • in the \BITMAP\ folder of the KAS-IDE.
Bitmap for "TRUE" state	<p>For two-state objects with the CUSTOM aspect, this specifies the pathname of the bitmap to display when the value of the attached variable is TRUE (or not zero for analogs).</p> <ul style="list-style-type: none"> • BMP, GIF, and JPG formats are supported. • If no directory is specified, the specified file name is searched: <ul style="list-style-type: none"> • in the project folder. • in the \BITMAP\ folder of the KAS-IDE.

Name	Description												
Bitmap pathname	<p>For bitmaps, this specifies the pathname of the bitmap to be displayed.</p> <ul style="list-style-type: none"> • BMP, GIF, and JPG formats are supported. • If no directory is specified, the specified file name is searched: <ul style="list-style-type: none"> • in the project folder. • in the \BITMAP\ folder of the KAS-IDE. 												
Border color	Indicates the color of the border drawn around the object.												
Border size	<p>Indicates the width of the border drawn around the object, expressed as a number of pixels.</p> <p>If this property is 0 (zero), no border is drawn.</p>												
Border style	<p>Indicates the possible 3D effect used for drawing the border around the object.</p> <p>Possible values are:</p> <ul style="list-style-type: none"> • 3D = default 3D effect • 3DDOWN = pressed 3D effect. • 3DUP = depressed 3D effect. • FLAT = no 3D effect. 												
Color when not connected	For shapes, this indicates the color used for filling shapes when no variable is attached to the graphic object.												
Data color	Indicates the color used to represent the value of a connected variable within the object (e.g., the filled part of a bar graph).												
Data format	<p>If defined, this indicates that the value of the connected variable must be displayed on the graphic object.</p> <p>This property requires a specified format string that indicates how the data is to be formatted.</p> <p>ⓘ IMPORTANT</p> <p>The "text" property is ignored when a data format is specified.</p> <p>Format string has the same format as the printf function of "C" language. It can include static characters together with one of these possible pragmas that specify the value:</p> <ul style="list-style-type: none"> • %s = default formatting according to IEC syntax • %d = integer (decimal) • %X = hexadecimal • %g = floating point • %.nf = decimal real (where n is the number of displayed decimal digits) <p>Examples</p> <table border="1"> <thead> <tr> <th>Format</th> <th>Value</th> <th>Displayed String</th> </tr> </thead> <tbody> <tr> <td>%d</td> <td>12.3</td> <td>12</td> </tr> <tr> <td>Var = %g meters</td> <td>1.2</td> <td>Var = 1.2 meters</td> </tr> <tr> <td>%.2f</td> <td>1.12345</td> <td>1.12</td> </tr> </tbody> </table> <p>NOTE</p> <p>Only one % pragma can be used in a string.</p>	Format	Value	Displayed String	%d	12.3	12	Var = %g meters	1.2	Var = 1.2 meters	%.2f	1.12345	1.12
Format	Value	Displayed String											
%d	12.3	12											
Var = %g meters	1.2	Var = 1.2 meters											
%.2f	1.12345	1.12											
Direction (bar graph)	For bar graphs, this indicates the growing direction: to the left, right, top, or bottom.												
Direction (basic shapes)	For oriented shapes such as triangles, half ellipses or cylinders, this indicates the direction of the drawing: to the left, right, top, or bottom.												

Name	Description
Direction (scale)	For scales, this indicates the direction of the axis. <ul style="list-style-type: none"> • If LEFT, the minimum value is on the left side. • If RIGHT, the minimum value is on the right side.
Direction (slider)	For slider, this indicates whether the slider is horizontal (RIGHT) or vertical (TOP).
FALSE color	For shapes, this indicates the color used for filling shapes when the attached variable has the FALSE state, or zero for analogs.
Font name	Indicates the name of the character font used for drawing texts in the graphic object.
Font size	Indicates the size of the character font used for drawing texts in the graphic object. <ul style="list-style-type: none"> • The size is expressed as a percentage of the actual height of the object. • Maximum possible value is 100. <ul style="list-style-type: none"> • This ensures that the ratio is kept when the object is resized.
Identifier	Freely attach a text identifier to each graphic object inserted in a document. Identifiers are useful for arranging overlapped objects as they appear in the Z-order list.
Link	Indicates the name of the target . <ul style="list-style-type: none"> • GRA animated document for shortcuts. • If no directory is specified in the link, the file is searched in the project folder.
Maximum value	For analog animated objects (e.g., meters, bar graphs, or trends) this indicates the maximum possible value that can be displayed. For static scales, it indicates the value of the highest mark.
Minimum value	For analog animated objects (e.g., meters, bar graphs or trends) this indicates the minimum possible value that can be displayed. For static scales, it indicates the value of the lowest mark.
Nb divisions (main)	For objects including a graphic scale, this indicates the number of main division marks to be drawn in the scale.
Nb divisions (small)	For objects including a graphic scale, this indicates the number of small division marks to be drawn in the scale, between each main division mark.
Nb of points (trends)	For trend charts, this indicates the maximum number of stored points. If the width of the object (in pixels) is less than this number, then oldest points are not visible.
Needle color	For gauges, this is the color of the needle.
Placement (scale)	For scales, this indicates the location of the scale within the object rectangle: on the left, right, top, or bottom.
Scale color	For objects including a graphic scale, this indicates the color used for drawing the axis, the division marks, and corresponding values of the scale.
Spying delay	It is the minimum period for actuating the value of the connected variable, expressed as a number of milliseconds. If the delay is not specified or equal to 0 (zero), refresh is done as fast as possible.
Text	If defined, this indicates the text displayed on the graphic object. <p>❗ IMPORTANT</p> <p>This property is ignored when a data format is specified.</p>
Text color	Indicates the color used for inserting texts in the graphic object.

Name	Description
Text mode	Indicates the font effect used for drawing texts in the graphic object. Possible values are: <ul style="list-style-type: none"> • BOLD = bold text. • HIDE = text is not displayed. • ITALIC = italic text. • NORMAL = normal font. • UNDERLINE = underlined text
Title	For gauges, this is the text shown in the tile
Title color	For gauges, this is the color of the title text.
Title placement	For gauges, this is the position of the title within the gauge.
TRUE color	For shapes, this indicates the color used for filling shapes when the attached variable has the TRUE state, or non zero for analogs.
Variable symbol	This is the full name of the application variable connected to the graphic object. In case of a local variable, its symbol must be prefixed with the parent program name, separated with "/". Example: MyProg/MyVar

9.3.2.7 Operate the Control Panel

The Example program has a default control panel built-in to make it easy to start an application.

Use this procedure to operate the control panel:

1. Double-click on **Control Panel** in the Project Explorer to open the form

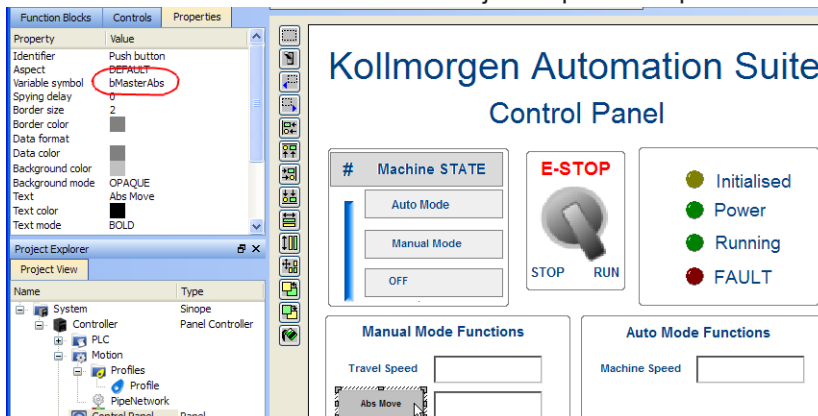

2. Start by moving the vertical slider bar to select the Machine STATE as **Manual Mode**.
3. In the Manual Mode Functions area, double-click the text box for the Travel Speed.
4. Enter the numeric value for the Travel Speed and press Enter.

9.3.2.7.1 KAS Simulator Display

The KAS Simulator displays the status and position of the axes. It also displays the log messages.

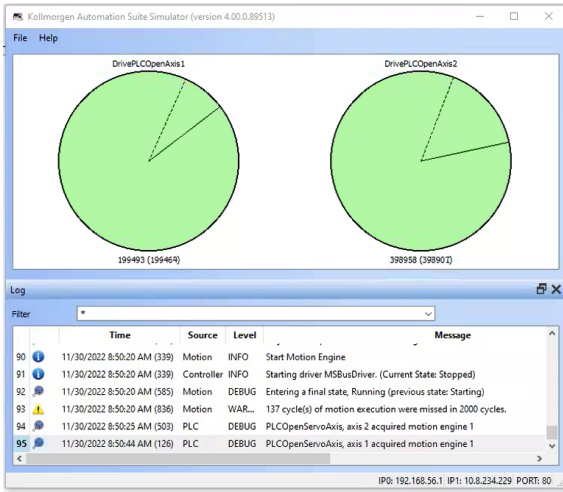

You can continue to use the Control Panel to:

- Experiment with the controls and observe the simulated output.
- Perform an absolute move by entering a position in the text box.
- Perform a relative move.

9.3.2.7.2 Exiting Simulation Mode

To exit Simulation mode, do as follows:

1. Click the **Stop Device** button .
2. Click the **Disconnect Device** button .

NOTE

For additional information about Kollmorgen Automation Suite, see this documentation:

- Getting Started
- User Manual
- Technical Reference - PLC Library
- Technical Reference - Motion Library
- Online Help

9.4 Pipe Network Editor

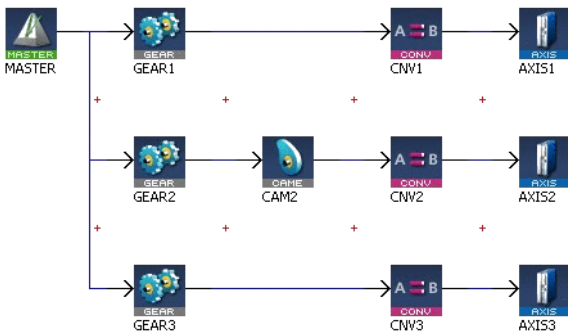

Figure 10-20: Pipe Network Structure

The Pipe Network Editor is a tool dedicated to the description of the motion part of the application ("Pipe Network Concept" (→ p. 727)).

Functions of the Pipe Network Editor are accessed via context sensitive menus.

When the Pipe Network Editor is used, an ST file containing all the calls to the Motion Library is automatically generated during compilation, and based on the graphical description of the Pipe Network.

Pipe Network Editor is optional

Although strongly recommended, the Pipe Network Editor is optional.

Use it to graphically create a Pipe Network or to manually instantiate Pipe and Pipe Blocks by calling the appropriate functions in the Pipe Library directly from the IEC 61131-3 editors (SFC, FBD, ST, IL, FFLD).

Grid

The layout of the editor is grid oriented, which means that items (except the comments) are placed in the middle of a rectangular area called a grid unit.

NOTE

Comments are not centered in the grid unit but merely placed at the cursor position.

9.4.1 Inserting Pipe Blocks or Comments

To insert Pipe Blocks or comments, right-click on a free grid unit and choose the corresponding command in the contextual menu.

9.4.2 Inserting Connections

Connections are simply inserted by clicking on an adequate point and dragging the mouse to another adequate point.

See "Adding Motion" (→ p. 158).

Connections are drawn between an input and an output port of two different Pipe Blocks.

Connections can be drawn from input to output ports or vice-versa.

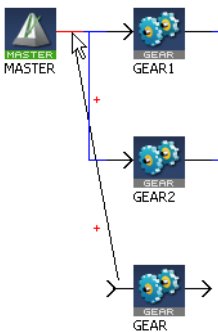

Figure 10-21: Pipe Network - Create a Link

When you try to connect two Pipe Blocks, the editor highlights the target port in red when the connection is allowed.

Relation type for output-input is 1-n

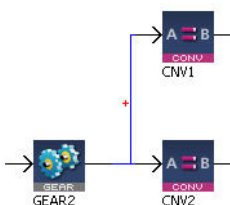

Figure 10-22: Pipe Block - Relation Type for Output-Input

One output can be connected to several inputs, but one input can only be connected to one output.

9.4.3 Connect a Comment to a Pipe Block

Connections are drawn between the text area of the comment (title bar is reserved for moving the comment) and the Pipe Block icon.

NOTE

The connection cannot be drawn from the Pipe Block to the comment. Allowed target is not highlighted.

9.4.4 Pipe Network Editor Controls

Basic Functions

This section details the basic moving and editing functionality with Pipe Network blocks.

Edit Pipe Blocks or Comments

To edit Pipe Blocks or comments, double-click an item to open its **Property** dialog box

NOTE

You can also access the property dialog box of an item through its contextual menu.

Move Pipe Blocks

Pipe Blocks are moved by dragging their center. When dragging a Pipe Block, a colored shadow is shown under the Pipe Block indicating where the Pipe Block is dropped. When the shadow fills out a complete grid unit, the Pipe Block is placed in this grid unit.

Move Connections

You can move an end-point of a connection from one item to another. To do this, select the connection and drag an end-point to a new target.

Move Comments

You can drag-and-drop a comment by selecting its title bar.

Remove Pipe Blocks, Comments and Connections

Select one or several items (Pipe Blocks, comments or connections) and choose **Delete Selection** in the menu.

NOTE

You can select several items by clicking on them while pressing either the Ctrl or Shift keys.

Insert rows and columns

When the shadow does not fill out a whole grid unit, but is squeezed between two grid units, a row or column is inserted before placing the Pipe Block in the newly created grid unit. When the Pipe Block is dropped on the crossing point of four grid units, a row and a column are inserted simultaneously.

NOTE

You cannot drop a Pipe Block into a grid unit which is already occupied by a Pipe Block or a comment.

Remove Rows and Columns

It is not possible to remove rows or columns. If a row or column has been inserted by error, click the **UNDO** icon in the toolbar (**Ctrl+Z**).

Multiple Selections

This section details selecting, moving, copying, pasting, and deleting multiple Pipe Network blocks.

	Delete Selection	Del
	Copy Selection	Ctrl+C
	Cut Selection	Ctrl+X
	Paste Here	Ctrl+V

Selecting multiple Pipe Network blocks.

Multiple blocks may be selected by either:

- Ctrl-clicking on individual blocks and connectors
- Click-dragging an area to select an area of blocks and connectors

Selected blocks will be highlighted and connectors will be red.

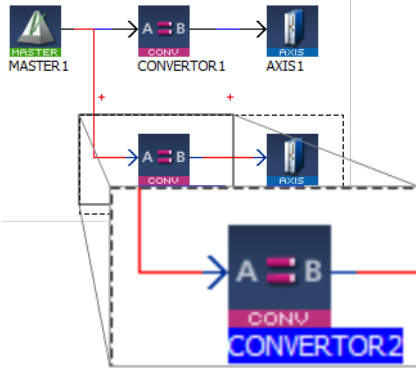

TIP

Be sure to select the connectors between blocks. If the connectors are not selected, any copied blocks will be unconnected.

Moving multiple Pipe network blocks.

Once selected, multiple Pipe Network blocks and connectors can be moved as a group. Simply click on a block and drag it to its new location. Light red rectangles show where the blocks will be placed. Narrow rectangles represent that a block will be placed between two current blocks, which will be moved to accommodate the repositioned blocks.

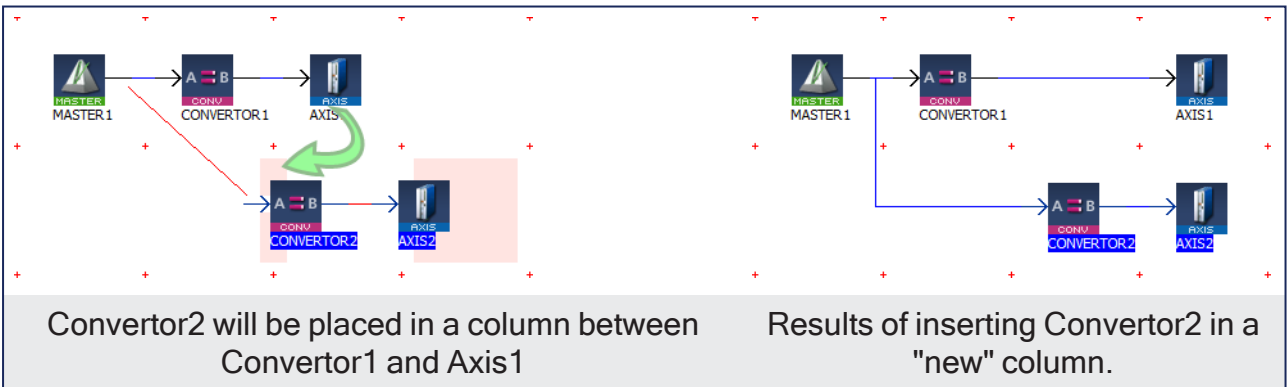

Copying multiple Pipe Network blocks.

Selected blocks and connectors may be copied by pressing Ctrl-C, or by using the right-mouse menu.

Pasting multiple Pipe Network blocks.

Selections may be pasted in one of two ways.

- Right-clicking in the Pipe Network Editor and selecting Paste Here.
 - Clicking in an empty location will place the blocks starting at that spot.
 - Clicking on an existing block will place the copied blocks on top of the selection. You will need to move the pasted blocks to see the entire network.
- Pressing Ctrl-V then clicking in the location you want the blocks to be placed.

TIP

Copied connectors will only be pasted when they are connected to a copied block.

Deleting multiple Pipe Network blocks.

Selected blocks may be deleted using either of two methods.

- Pressing the **Delete** key.
- By right-clicking on a selection and choosing **Delete Selection**.

9.4.5 Plug/Unplug Channels

Right-click on a Pipe Block to plug/unplug a channel of the Softscope. For more details, refer to (→ # 236, Plug Motion Variables).

9.5 Soft Oscilloscope

The soft oscilloscope (commonly known as softscope or scope) is a tool used to view, in a two-dimensional graph, one or more variable's evolution (vertical axis) across the time (horizontal axis).

- The scope (e.g., Figure 10-23: "Example of using the Oscilloscope") has a set of channels where each can acquire the evolution of a value.
- A value may be the feedback position of an axis, the speed of a machine, or anything else that can be measured with the oscilloscope probes.
- See "Plugging Probes, Mapping Variables" (→ p. 492) for more information about how to assign a variable to a channel.

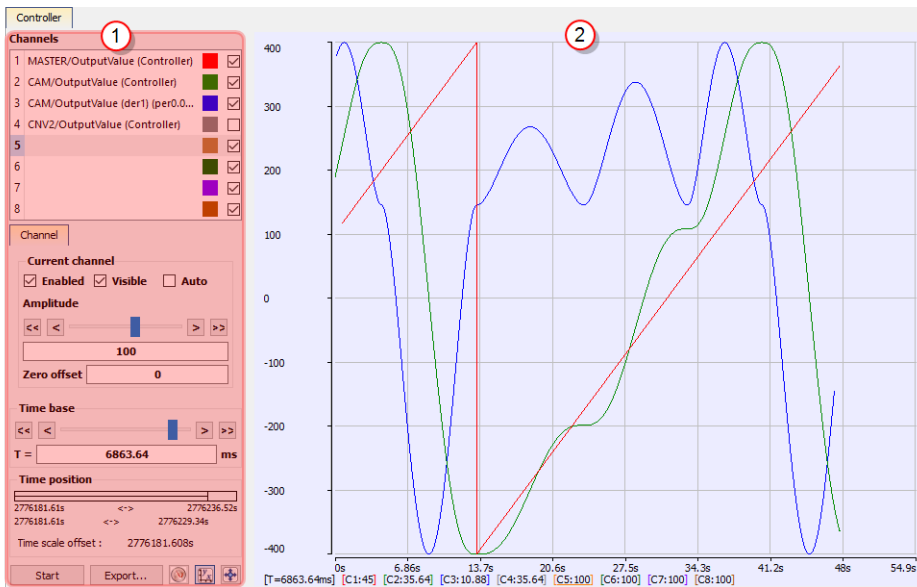

Figure 10-23: Example of using the Oscilloscope

The soft oscilloscope is a child window in the workspace.

This workspace has two visually distinct parts separated by a splitter which allows you to change the size of the two panes.

9.5.0.1 Control Panel

- The "Oscilloscope Control Panel" (→ p. 486) (1) is used to:
 - Assign variables to a channel.
 - Change the settings of the soft oscilloscope (including those of the channels).

9.5.0.2 Graphical Area

- The "Oscilloscope Graphical Area" (→ p. 491) (2) shows the traces (or variable values) acquired by the channels.

TIP

You can hide the control panel by dragging the splitter all the way to the left. To show the control panel again, click and drag the splitter to the right.

9.5.1 Access the Soft Oscilloscope

In order to access the softscope, select the **Oscilloscope** command from the **Tools** menu.

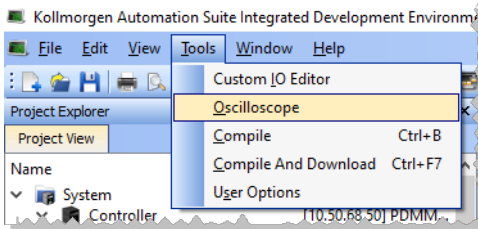

Figure 10-24: Accessing the Scope

9.5.2 About OpenGL

For the Graphical Area, the scope uses **OpenGL** for performance reasons.

If you encounter problems in the quality of drawings, we suggest that you consider these options before contacting our support desk:

[Verify the graphic card driver is up-to-date.](#)

Newer drivers often fix the rendering bugs of OpenGL.

[Disable some optimizations on the Display hardware acceleration](#)

1. Open your operating system's **Display Properties**¹.
2. In the **Settings** tab, click the **Advanced** button.
3. Select the **Troubleshoot** tab.
4. If **Hardware acceleration** is set to full, try to disable some optimizations.

This procedure has proven to be useful in particular with cursor drawing problems that appear when the user performs high-zooming operations (the cursor can indicate a value which is out of the trace).

[Change the settings of the graphic card](#)

Open the manufacturer-specific settings of your graphic card.

If there are some settings related to **Performance and quality**, try to set them to **quality** (but not high quality) instead of performance, at least for the program **kaside.exe**.

This solves many drawing problems that occur when zooming a lot in the graph.

[Display a given amount of samples, according to the refresh rate](#)

If your channels have acquired a large number of samples, and the refreshing of the graph does not occur frequently enough, do not display all samples at the same time either by:

¹The Properties command is accessible in the contextual menu on your desktop (you can also access the Display from the Windows Control Panel)

- Hiding some less useful channels (use the visibility property in the "Oscilloscope Control Panel" (→ p. 486))
- Reducing the time-base and/or restricting the time-frame in the time position.
In any cases, this action does not stop acquisition or lose your acquired samples.

ⓘ IMPORTANT

Disabling most or all OpenGL accelerations is compensated by an increase in CPU consumption. It can lead to a point where the soft oscilloscope is not very usable when limited hardware is trying to display loads of samples.
See "System Requirements" (→ p. 40) for more information.

9.5.3 Oscilloscope Control Panel

Figure 10-25: "Oscilloscope Control Panel" shows the control panel with these items:

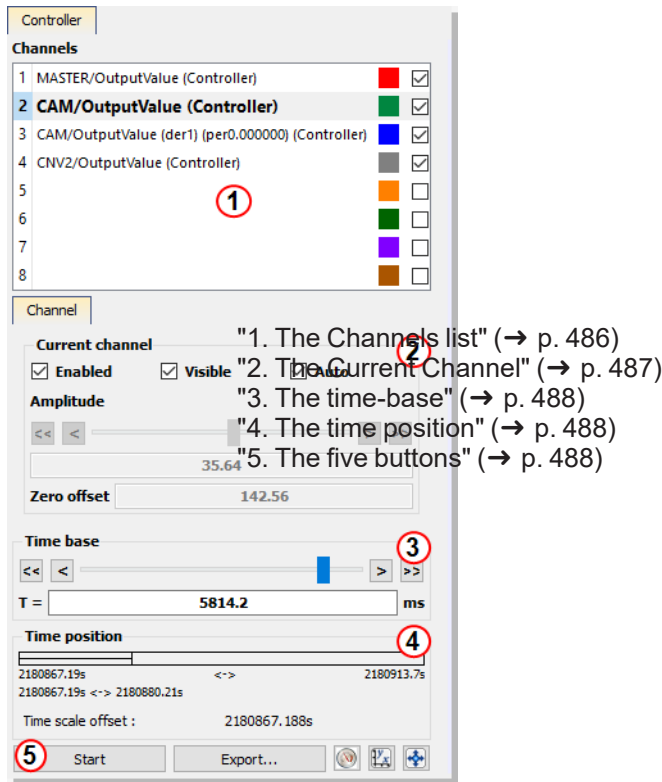

Figure 10-25: Oscilloscope Control Panel

1. The Channels list

This lists the eight available channels and the variables assigned to each.

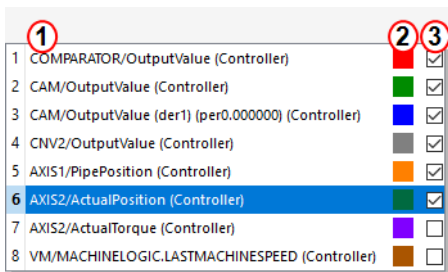

Figure 10-26: Scope Control Panel - Channels

Each channel shows:

- The **name** of the associated variable **1**.
- The **color** of the associated trace in the graph with a color icon **2**.
- The **visibility** of the associated curve with a check box **3**.
 - This is to quickly show/hide each captured trace.

TIP

Change the color of a curve by double-clicking on its color icon and its visibility by clicking on its check box.

TIP

Right-click on a channel to map, unmap, or edit the color of a variable's trace.

When selecting a channel in the channels list, it is superimposed on the existing traces, and some related information are displayed on the left and lower sides of the graph.

2. The Current Channel

This section details the properties of the currently selected channel.

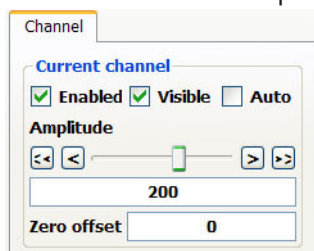

Properties	Description
Enabled	A channel has to be enabled to acquire the samples sent by its associated probe.
Visible	A channel has to be visible to be drawn on the graph. Even if not visible, it continues to acquire the samples sent by its associated probe.
Auto	A channel in auto mode automatically adapts its amplitude (unit/division ¹) and zero offset to display all its samples. <ul style="list-style-type: none"> • Setting the auto mode disables the possibility of changing the Amplitude and the Zero offset. • See (→ # 496, Setting Scale) for more information about scaling.
Amplitude	Controls the amplitude (unit/division) of the channel. <ul style="list-style-type: none"> • The buttons and slider change the amplitude according to a logarithmic scale. • The dialog box allows a more precise definition of the value.
Zero offset	The curve is vertically shifted so that this value is located halfway through the graph height.

NOTE

On some special devices, some more tabs that are specific to extra configurations appear in this widget. Example: S300 device provides trigger functionality, so an additional tab appears for the trigger configuration.

¹The term refers to the time-base value for the X-axis and to the amplitude value for the Y-axis. For example, if the user sets a time-base of 10ms and an amplitude of 1, each division in the soft oscilloscope grid corresponds to a time of 10ms for the X-axis and an amplitude of 1 for the Y-axis.

3. The time-base

This enables you to set the speed at which all the lines for each channel are drawn, and is calibrated in milliseconds per division.

- Its usage is similar to the Amplitude property described in the above section.
- The time-base can always be changed, even during sampling (see "Time Scale" (→ p. 496)).

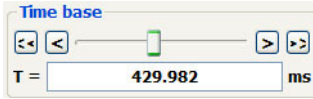

Figure 10-27: Scope Control Panel - Time-base

To setup the time-base properly, the total measurement duration and the required time resolution have to be taken in account.

4. The time position

This enables you to change the time-frame of the acquired samples shown on the graph. It is composed of:

- A single **horizontal line** represents all the acquired samples with start and stop timings.
- A **rectangle** represents only the time slot of the acquired samples shown in the graphical area (the time-frame) with timings:



Figure 10-28: Scope Control Panel - Time Position

NOTE

The acquisition of samples is limited to 100'000 cycles (ie. 100 s when cycle time is set to 1000 µs, and 25 s when cycle time is set to 250 µs). When you reach this limit:

- The first data that are added to the queue are the first data to be removed (FIFO queue)
- The start timing increases

You can change the time slot with the mouse by:

- moving the rectangle
- changing the size

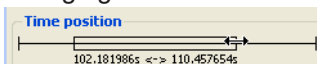
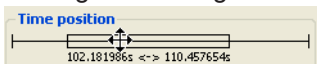

The **Time Scale Offset** is the time value of the first sample the graph when plotting is started. Using this as an offset, the time axis is always started at 0 seconds. To get the actual time value of any sample, add the time scale offset to the Time axis value.

$$\text{Actual Sample Time Value} = \text{Time Scale Offset} + \text{Time axis value}$$

How to set the time-frame?

When clicking anywhere on the horizontal line, the time-frame is centered on the clicked point. It is also possible to move the time-frame by clicking on its rectangle part and dragging.



You can resize the time-frame in a user-friendly manner by clicking on its left or right ends and dragging.

NOTE

During acquisition the time position item is disabled and displays the progression of acquisition.

5. The five buttons

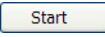
At the bottom of the controls are five buttons:

1. The **Start/Stop** button  is used to start or stop the acquisition of samples. When starting acquisition, all previous samples are lost.
2. The **Export...** button  is used to save the acquisition data in a CSV file. See [click here...](#) for more information.
3. The **Plug Trace Times Channels** button  is used to quickly load and display these channels:
 - **Channel 1: Cycle Jitter** (in μs)

When the motion is started, the current cycle time remains constant on an average of several cycles, and equal to the EtherCAT cycle time which is a constant value (1000, 500 or 250 μs).

The CycleJitter is due to EtherCAT transmissions that can vary in a particular cycle (i.e., call out **1**).

The channel 1 of the scope monitors the time difference between the expected Cycle Time and the actual Cycle Time:

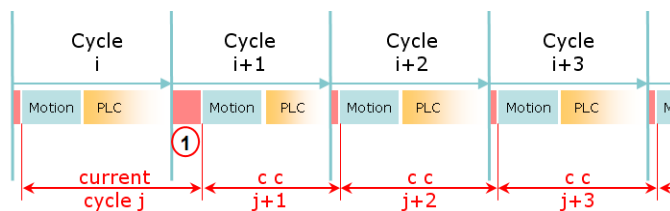

Figure 10-29: Cycle Time Calculation

- **Channel 2: Motion execution time** (microseconds)
- **Channel 3: PLC execution time** (microseconds)
- **Channel 4: AKD PDMM or PCMM - Real Time Margin** (microseconds)
 - This channel monitors the available execution time: $(\text{Cycle Time Period} \times \text{Controller Core Count} - \text{EtherCAT network execution time} - \text{MotionExecTime} - \text{PLCProgExecTime})$.
 - The measurement is based on CPU usage, which provides the most accurate measurement.
 - The measurement is updated each cycle period.

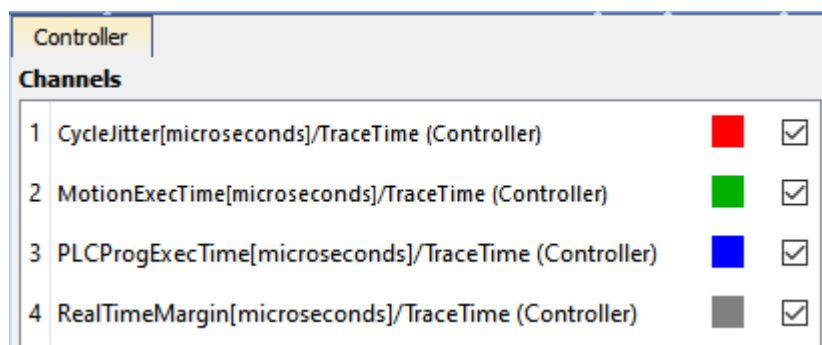

Figure 10-30: AKD PDMM or PCMM - O-Scope Trace Times Channels

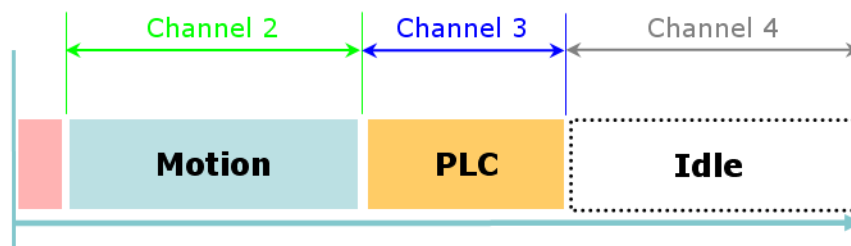
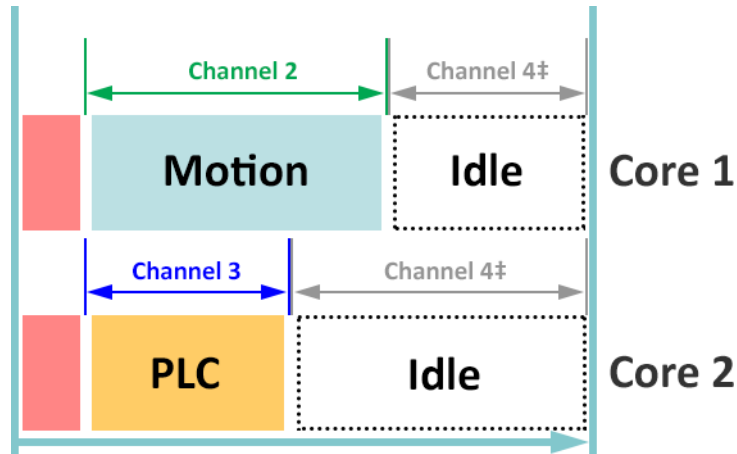

Figure 10-31: AKD PDMMor PCMM - Single Core Controller, Motion, PLC and Real Time Margin Time Calculations



‡ Channel 4 is the total amount of time across all CPU cores.

Figure 10-32: PCMM M2-120 model - Dual Core Controller, PLC and Real Time Margin Time Calculations

- **Channel 4: PCMM2G - PLC Margin** (microseconds)
 - This channel monitors the available execution time for the PLC within a cycle: (Cycle Time Period - EtherCAT network execution time - PLCProgExecTime).
 - The range is 0 to cycle period in microseconds.
 - The measurement is calculated and updated each cycle period.
 - If the PLC execution time spans multiple cycles, then the PLC Margin Time is zero.

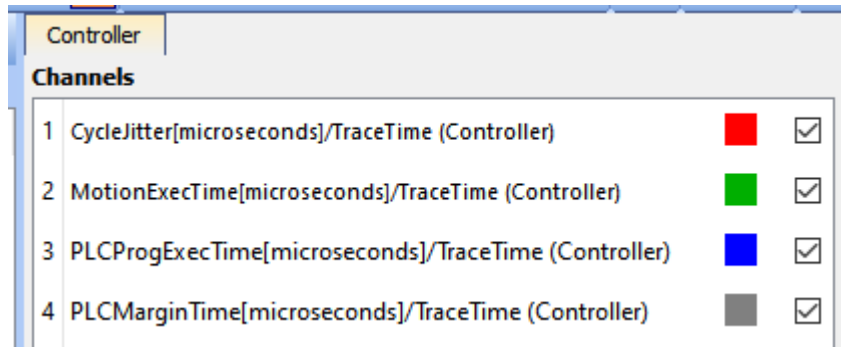

Figure 10-33: PCMM2G - O-Scope Trace Times Channels



Figure 10-34: PCMM2G - Multiple Core Controller, PLC and PLC Margin Time Calculations

- **Simulator**
 - **Channel 1:** Not supported.
 - **Channel 2: Motion execution time** (microseconds)
 - **Channel 3: PLC execution time** (microseconds)
 - **Channel 4:** Not supported.
 - **Channel 1** (CycleJitter) and **Channel 4** (RealTimeMargin) are always zero with the simulator.

- The MotionExecTime and PLCProgExecTime traces are visible with simulated values.

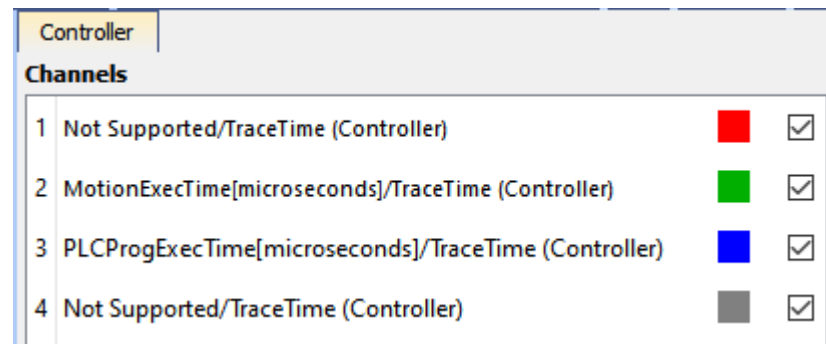



Figure 10-35: Simulator - O-Scope Trace Times Channels

See "Tasking Model / Scheduling" (→ p. 819) for more information

4. The **graduations** button () displays or removes the axis graduations of the graphical area. By graduations are visible by default.
5. The **autofit** button () changes the time-frame of the graph and amplitudes. It zero offsets of channels so they all fit entirely into the graphical area.

9.5.4 Oscilloscope Graphical Area

The graph displays a subset of the collected data: the **time-frame**.

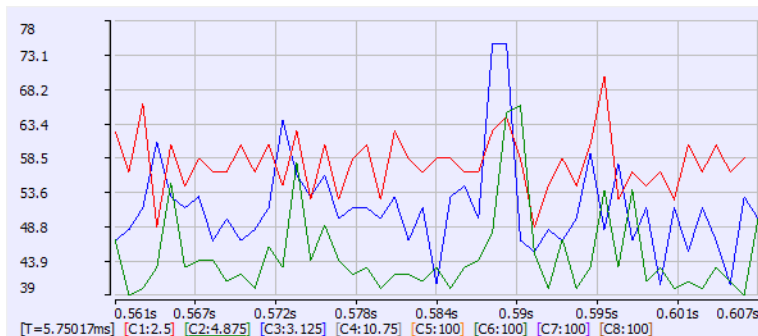

Figure 10-36: Example of the traces generated in the Oscilloscope.

To better view and analyze the data, the graph has the following features:

- **Graduations** are displayed on the left and lower sides of the graph
- Information concerning the time-frame of the graph and the amplitude of channels also appears at the bottom of the graph. The current channel amplitude is underlined and the coordinates of the nearest collected sample are displayed
- It is possible to **zoom** in the graph using various methods (for more details, see (→ # 497, Trace Zoom Feature))
- It is possible to **move** the contents of the graph within the time-base (for more details, click here...)

NOTE

Moving the contents is possible **only** when the acquisition is stopped.

See "How Do I Export the Oscilloscope Data?" (→ p. 497) for information on capturing the trace data.

9.5.5 Traces

The trace is the resulting graph of the variable's evolution against time, with the more distant past on the left and the more recent past on the right.

NOTE

The acquisition of samples is limited to 100'000 cycles (ie. 100 s when cycle time is set to 1000 μ s, and 25 s when cycle time is set to 250 μ s). When you reach this limit:

- The first data that are added to the queue are the first data to be removed (FIFO queue)
- The start timing increases

9.5.6 Plugging Probes, Mapping Variables

A probe is a virtual measurement point that can be connected to a variable.

These types of variables can be mapped:

- Pipe Block variable
- IEC 61131-3 variable, which is any other variable.
- PLCopen axis values.

NOTE

Your application **must be connected and running** to plug a variable to the channel.

You can connect a probe to a variable in one of these ways:

- From the Softscope, see "Mapping a Variable to the Oscilloscope" (\rightarrow p. 492).
- From the Dictionary, see "Plug a Probe from the Dictionary" (\rightarrow p. 494).
- From the Pipe Network, see "Plugging a probe from the Pipe Network" (\rightarrow p. 495).

9.5.6.1 Mapping a Variable to the Oscilloscope

A probe (variable) can be directly plugged or mapped from within the Oscilloscope:

1. Right-click on any channel (already mapped or not) in the channels list.
2. Click the **Map** option to open the **Scope Variable Selector**.

NOTE

If your application is not connected and running, this message appears.

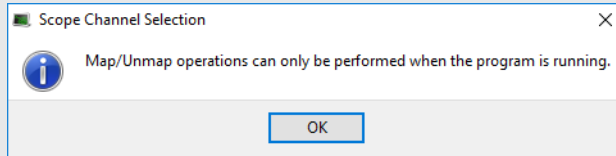

- Navigate through the available variables and select the one you want to connect to the channel.

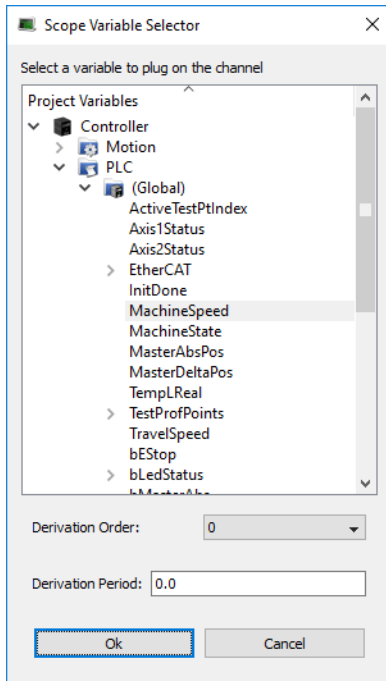

Figure 10-37: Using the Variable Selector to choose a variable to be mapped in the Oscilloscope

NOTE

The **Scope Variable Selector** contains only the PLC variables eligible for the Softscope as long as they are not in a **UDFB instance**.

This includes: BOOL, BYTE, DINT, DWORD, INT, LINT, LREAL, LWORD, SINT, TIME, UDINT, UINT, ULINT, USINT, WORD.

Additionally, only a subset of variables are displayed (e.g., ActualVelocity¹ is not visible), when in Simulated mode.

For more details see:

- Axis pipe block positions; click here....
- PLCOpen Axis positions; "Axis Positions Data" (→ p. 766).

- (Optional) Set the **Derivation Order**.

This is the number of derivatives to apply to the trace.

If the variable selected is the axis command position, then setting the **Derivation Order** to:

- 1 generates a trace for the axis command velocity.
- 2 generates a trace for the axis command acceleration.
- 3 generates a trace for the axis command jerk.

- (Optional) Set the **Derivation Period**.

The value entered should be either 0.0 (no modulo) or the Modulo Period (e.g., 360.0).

If the selected Derivation Order is greater than zero, the Derivation Period of the selected signal can be used to remove rollover spikes in the derivative value if the variable is of a periodic nature as the result of modulo behavior.

9.5.6.1.1.1 Un-map Variables from the Scope

Use this procedure to disconnect a probe:

¹The measured value is the instant velocity of the axis in RPM*1000.

Some oscillations are visible because it is an instant velocity, not an average velocity.

1. Right-click on the channel to remove from the channels list and select the **Unmap** command in the menu to disconnect the probes.
2. Select the **Unmap all Oscilloscope Channels** command from the right-mouse menu in the Dictionary or the Pipe Network.

9.5.6.2 Plug a Probe from the Dictionary

A probe (variable) can be directly plugged or mapped to the Oscilloscope from the Dictionary:

1. In the **Dictionary**, right-click on the variable
2. In the menu, select the **Map to Oscilloscope channel ...** command

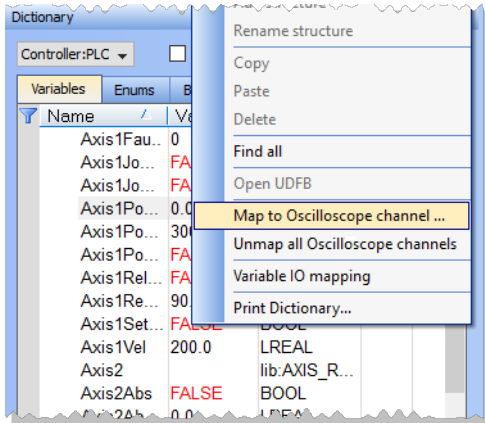

Figure 10-38: Plugging a Probe from the Dictionary

NOTE

This command is enabled if the variable "Data Types" (→ p. 702) is eligible for the softscope, as long as they are not in a UDFB instance.

3. Define the probe parameters.
 There is a difference depending upon whether you selected a Pipe Network probe or a PLC probe. With Pipe Network variables, select which Data point is being used. PLC variables may require navigation within the group to find the correct item.

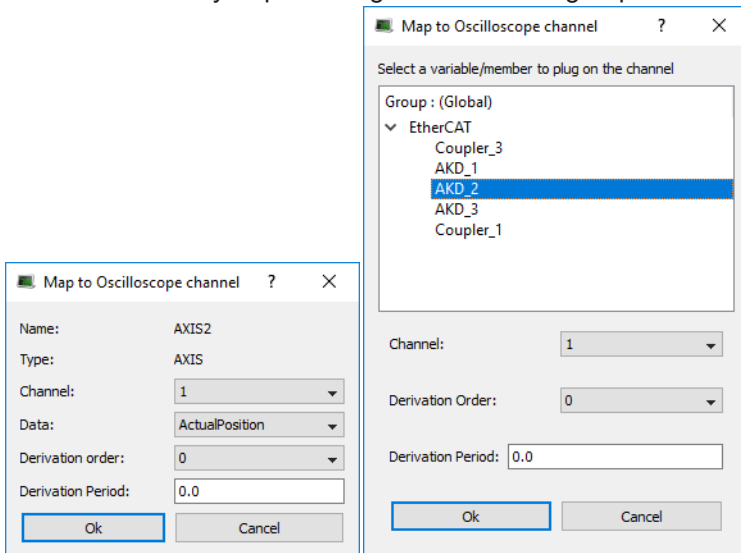

Figure 10-39: Associating a Pipe Network (left) and PLCopen (right) variable to a Channel.

Field	Description
Channel	Channel's number where the variable has to be plugged

Field	Description
Data	Desired variable information to show (the list depends on the type of Pipe Block).
Derivation Order	Performs a derivation of the measurement of the selected variable. If this value is different from 0 (zero), the derived value of the selected order is shown on the selected channel.
Derivation Period	Specifies the modulo period for a periodic variable to remove spikes in the display of derivative orders greater than zero. The value entered should either be 0.0 (No Modulo) or the Modulo Period (e.g., 360.0).
Name	Variable's name.
Type	Variable's type.

NOTE
To enable the **Plug on channel...** dialog box, the KAS-IDE must be connected to the device first!

9.5.6.3 Plugging a probe from the Pipe Network

A probe (variable) can be directly plugged or mapped to the Oscilloscope from the Pipe Network:

1. Right-click on a Pipe Block
2. Select **Plug on channel...** in the menu

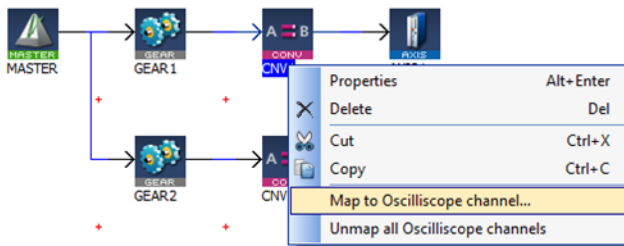
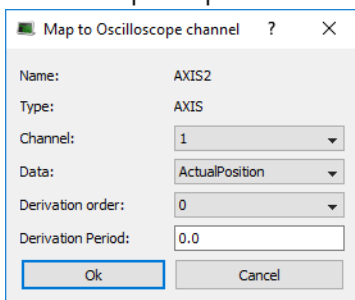

Figure 10-40: Plugging a Probe from the Pipe Network

3. Define the probe parameters.



Field	Description
Channel	Channel's number where the variable has to be plugged
Data	Desired variable information to show (the list depends on the type of Pipe Block).
Derivation Order	Performs a derivation of the measurement of the selected variable. If this value is different from 0 (zero), the derived value of the selected order is shown on the selected channel.

Field	Description
Derivation Period	Specifies the modulo period for a periodic variable to remove spikes in the display of derivative orders greater than zero. The value entered should either be 0.0 (No Modulo) or the Modulo Period (e.g., 360.0).
Name	Variable's name.
Type	Variable's type.

NOTE

To enable the **Plug on channel...** dialog box, the KAS-IDE must be connected to the device first!

9.5.7 Setting Scale

The soft oscilloscope graph is divided into eight units for the horizontal time scale (X-axis) and eight units for the amplitude (Y-axis). These units can be user-defined by using the configuration panels described below.

NOTE



Unit per ulision: This is the time-base value for the X-axis and to the amplitude value for the Y-axis.
Example: If the user sets a time-base of 10ms and an amplitude of 1, each ulision in the soft oscilloscope grid corresponds to a time of 10ms for the X-axis and an amplitude of 1 for the Y-axis.

9.5.7.1 Time Scale

Time Scale

The time scale can be configured with the **Time-base** configuration panel.

- The default value is 100ms/unit with the limits being 0.1ms to 25,000ms.
- The new value can be entered by hand directly in the text field or by using the buttons:

Buttons	Description
	Used to divide / multiply the time-base by 2 (performing a division corresponds to a zoom in while performing a multiply corresponds to a zoom out).
	Used to divide / multiply the time-base by 10.

The base time unit is 1 ms.

TIP

Modify the time scale by scrolling the mouse wheel with the cursor located in the graphical area.

9.5.7.2 Variable Scale

Variable Scale

Variable scaling is done by modifying the [amplitude](#) and [offset](#) value of a channel.

The variable scale can be configured in different places:

- The [Current channel](#) control panel.
- The [Edit all channels](#) dialog.

TIP

You can also modify the variable scale by pressing down the Ctrl key while scrolling the mouse wheel with the cursor located in the graphical area.

NOTE

The changes affect only the selected channel.

9.5.8 Trace Zoom Feature

The zoom feature is used to magnify or reduce a portion of a trace. Two zoom modes are available:

Time zoom	Used to expand/collapse the time-base in order to have a better view of the signal evolution through time. This zoom operation updates the time-base value.
Amplitude zoom	Used to have a better view of a part of a signal. This zoom operation updates the amplitude & zero offset value

The zoom operations can be done:

- By modifying the corresponding values by hand
- By using the mouse wheel

For more details on setting the amplitude, zero offset and time-base values, refer to (→ # 496, Setting Scale).

Mouse Shortcuts

Action	Result
Scrolling up the mouse wheel	Expands the time-base value
Scrolling down the mouse wheel	Collapses the time-base value
Pressing the Ctrl key while scrolling up	Makes the amplitude value greater
Pressing the Ctrl key while scrolling down	Makes the amplitude value smaller

NOTE

When performing an amplitude zoom, the zero offset is automatically set by the cursor position.

9.5.9 How Do I Export the Oscilloscope Data?

To copy the trace data into a CSV file:

1. Display the softscope
2. Ensure the channels you want to export are [Enabled](#) and [Visible](#)
3. **Start** the data collection
4. Wait for the probe data you want to save to be collected
5. **Stop** the data collection
6. Click the **Export...** button
7. Select where you want to save the CSV file
8. Click the **Save** button

[A tip about waiting for all channels to be recording before capturing Scope data.](#)

Channels start recording a few cycles after the previous channel, based on resources. To see all channels at same time you need to wait until data is being sent from all channels. If you start the capture at the first cycle the exported data will not line up. The first table below shows aligned data of the channels from starting the program. Note how it takes several cycles for the data to be captured. The second table shows how his data would appear in a CSV file. Note how the time columns do not match. Waiting for all channels to be recording will eliminate this.

Time	Channel 1	Time	Channel 2	Time	Channel 3	Time	Channel 4
0	499.9996						
1	499.9996						
2	499.9996						
3	499.9996						
4	499.9996	4	-31.543				
5	499.9996	5	-31.843				
6	499.9996	6	-32.1411				
7	499.9996	7	-32.4428				
8	499.9996	8	-32.7429				
9	499.9996	9	-33.0429	9	-534.543		
10	499.9996	10	-33.343	10	-531.843		
11	499.9996	11	-33.6431	11	-535.143		
12	499.9996	12	-33.9428	12	-535.443		
13	499.9996	13	-34.2428	13	-535.742		
14	499.9996	14	-34.5429	14	-536.043		
15	499.9996	15	-34.843	15	-536.343	15	-459.028
16	499.9996	16	-35.143	16	-536.643	16	-458.728
17	499.9996	17	-35.4431	17	-536.943	17	-458.428
18	499.9996	18	-35.7428	18	-537.242	18	-458.128
19	499.9996	19	-36.0429	19	-537.542	19	-457.829

Table 1: Scope output is aligned to show actual results

Time	Channel 1	Time	Channel 2	Time	Channel 3	Time	Channel 4
0	499.9996	4	-31.543	9	-534.543	15	-459.028
1	499.9996	5	-31.843	10	-531.843	16	-458.728
2	499.9996	6	-32.1411	11	-535.143	17	-458.428
3	499.9996	7	-32.4428	12	-535.443	18	-458.128
4	499.9996	8	-32.7429	13	-535.742	19	-457.829
5	499.9996	9	-33.0429	14	-536.043	20	-459.028
6	499.9996	10	-33.343	15	-536.343	21	-458.728
7	499.9996	11	-33.6431	16	-536.643	22	-458.428
8	499.9996	12	-33.9428	17	-536.943	23	-458.128

Time	Channel 1	Time	Channel 2	Time	Channel 3	Time	Channel 4
9	499.9996	13	-34.2428	18	-537.242	24	-457.829
10	499.9996	14	-34.5429	19	-537.542	25	-459.028
11	499.9996	15	-34.843	20	-535.742	26	-458.728
12	499.9996	16	-35.143	21	-536.043	27	-458.428
13	499.9996	17	-35.4431	22	-536.343	28	-458.128
14	499.9996	18	-35.7428	23	-536.643	29	-457.829
15	499.9996	19	-36.0429	24	-536.943	30	-459.028
16	499.9996	20	-35.143	25	-537.242	31	-458.728
17	499.9996	21	-35.4431	26	-537.542	32	-458.428
18	499.9996	22	-35.7428	27	-536.943	33	-458.128
19	499.9996	23	-36.0429	28	-537.242	34	-457.829

Table 2: Actual output to CSV file for Scope data captured from the start

You can now import the data into Microsoft Excel.

NOTE

The Export operation is possible even when acquisition of samples is in progress. But in that case, the latest exported data are the data collected when you have defined the CSV file.

NOTE

The acquisition of samples is limited to 100 s when the cycle time is set to 1000 μ s (respectively 50 s with 500 μ s, and 25 s with 250 μ s)

About the CSV file format

Each channel takes 2 columns: one for the **time** and the other for the **value**. This allows exporting channels with different [time-base](#).

The **List separator** and the **Decimal symbol** are hard-coded (they are not bind to the regional settings)

- List separator is comma (,)
- Decimal symbol is dot (.)

TIP

If your regional settings are different, then you have to specify explicitly those two characters in Microsoft Excel to correctly import the CSV file

9.5.10 Practical Application: Using Trace Time To Measure CPU Load

To determine the overall controller CPU usage, look at the HW Status tab on the **Diagnostics** page of the controller's web server.

NOTE

The technique to measure the CPU load is similar but the load limits change with the:
 Single and dual-core AKD PDMM / PCMM.
 Quad-core PCMM2G.

9.5.10.0.1 AKD PDMM / PCMM

- If the **CPU usage** is:
 - Less than 90%, the CPU load (both Real Time and Non-Real Time) is okay.
 - 90% or higher, the CPU is too heavily loaded.
 - It should be reduced by simplifying the application or reducing the CycleTime update rate.

9.5.10.0.2 PCMM2G

- The CPU usage alone may not provide an accurate indicator of the Motion and PLC CPU usage.
 - This is because the CPU usage is the average of all the CPU cores.

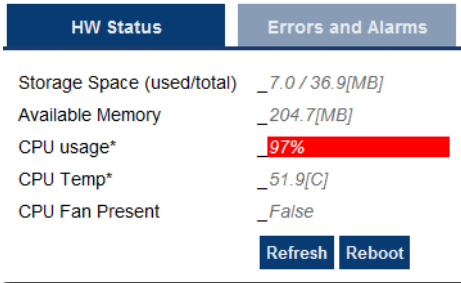

9.5.10.1 Oscilloscope Trace Times

The IDE Oscilloscope trace times can be used to analyze the application performance on a controller or programmable drive.

This section describes techniques used to interpret the trace times to examine the real-time performance.

There are two major parts to consider when evaluating total performance:

- **Real Time:** EtherCAT + Motion Engine + PLC program.
- **Non-Real Time:** Everything else (the background tasks).

The Oscilloscope trace times provide a very good tool to examine the Real Time response.

- Although it doesn't provide the complete system picture, it is a good place to start.
- It can provide some indication about the Non-Real Time load.
 - However, the best indicator is the overall **CPU usage** and the Controller Log messages.

You need to know the Cycle Time for the system.

From the **Project View**, select the **EtherCAT** view and the "EtherCAT Master Settings tab" (→ p. 327).

The update period for the system in this example is set to 250 microseconds.

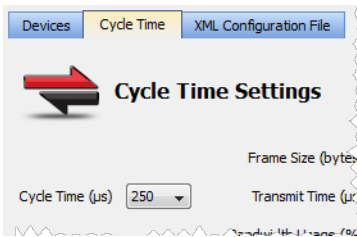

Figure 10-41: Cycle Time tab

The **Trace Times** traces are enabled by pressing the **Plug Trace Times channels** button in the Oscilloscope view when your application program is running.

This button automatically configures the Channels:

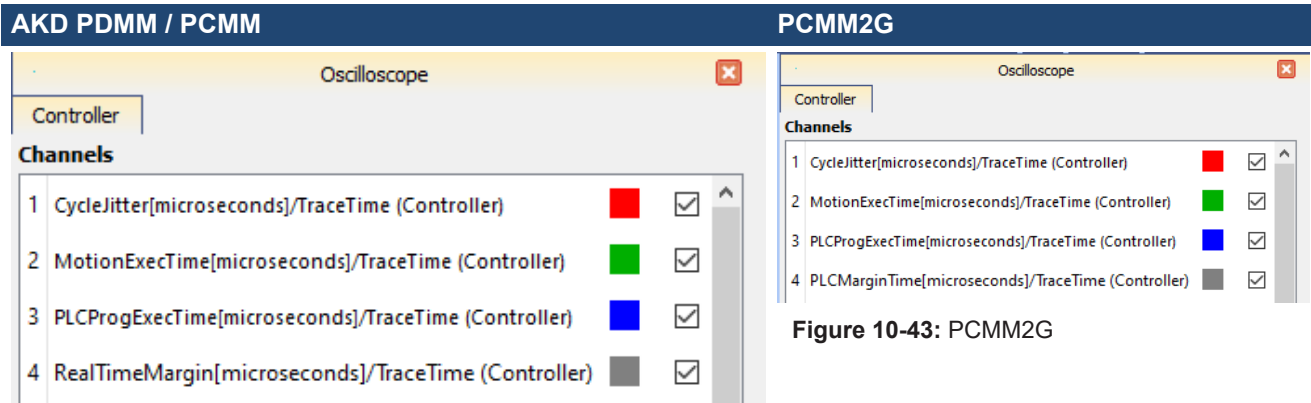

Figure 10-43: PCMM2G

Figure 10-42: AKD PDMM / PCMM

9.5.10.1.1 Press the Start Button to Collect Some Data

The first thing to do is to collect data during the normal application operation, particularly once the system has reached a steady state.

Press **Start** and let the data collect for a few seconds and then press the **Stop** button.

The first traces to examine are the **MotionExecTime** and **PLCProgExecTime**.

Configure the **Amplitude** and **Zero offset** so you can see both traces easily.

This table shows some recommended values based on several Cycle Time values:

Cycle Time	Amplitude	Zero Offset
250ms	20	80
500ms	40	160
1000ms	80	320

TIP

Clearing checkboxes for the **CycleJitter** and **RealTimeMargin** or **PCLMarginTime** traces is useful so they don't clutter the view.

Example

This example has a Cycle Time of 250 microseconds.

- The **MotionExecTime** average is about 27 microseconds.
- The **PLCProgExecTime** average is about 68 microseconds.

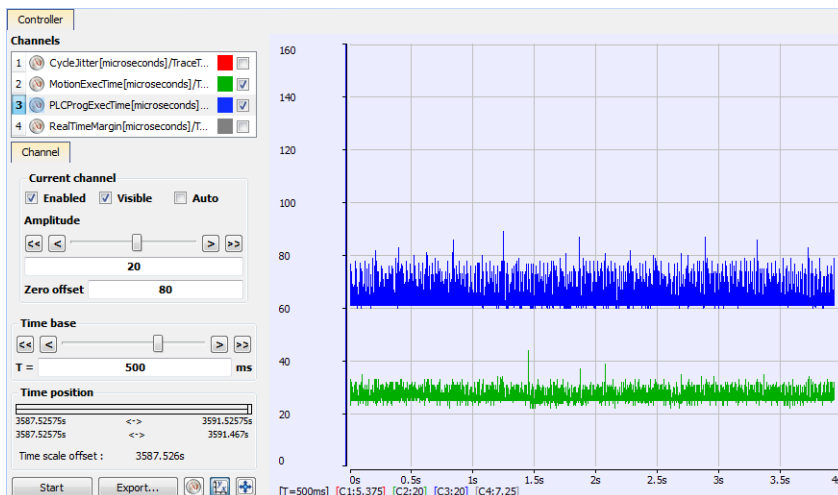

Figure 10-44: PLCProgExecTime and MotionExecTime

For single-core controllers, we want to investigate the combined percentage of cycle time for both the **MotionExecTime** and **PLCProgExecTime**.

- The average time for the **MotionExecTime + PLCProgExecTime** is 95 (27 + 68 = 95).
 - This is about 38% of the cycle (95 / 250).
 - This is a good value.

For multi-core controllers, we want to investigate the percentage of cycle time for each **MotionExecTime** and **PLCProgExecTime** individually.

- **MotionExecTime** is about 11% of the cycle.
- **PLCProgExecTime** is about 27% of the cycle.
 - These are both good values

9.5.10.2 Check the Peak Times

The next step is to examine the spikes.

We will examine the **MotionExecTim**, **PLCProgExecTime**, **RealTimeMargin** or **PLCMarginTime** and **CycleJitter** traces.

1. Reduce the **Time** base and move the traces left or right with the mouse while holding the left mouse button.
2. Position the cursor to measure the peak.

In this example:

- The **MotionExecTime** peak is 44.
- The **PLCProgExecTime** peak is 89.
 - This is reasonable.

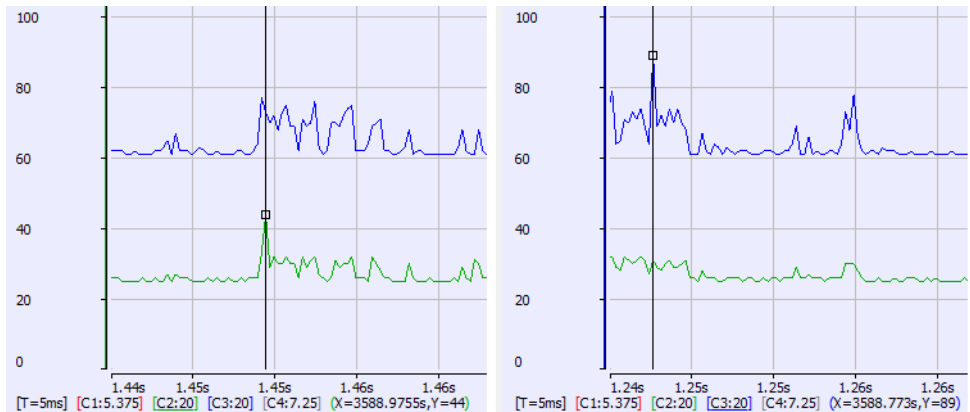

Figure 10-45: Peak Times

9.5.10.2.1 RealTimeMargin or PLCMargin Time

AKD PDMM / PDMM

To view the **RealTimeMargin**, configure the **Amplitude** and **Zero offset** so you can see the trace near zero.

In this example:

- The minimum (closest to zero) is 69 microseconds.
- This provides a 28% (69 / 250) **RealTimeMargin** (which is good).

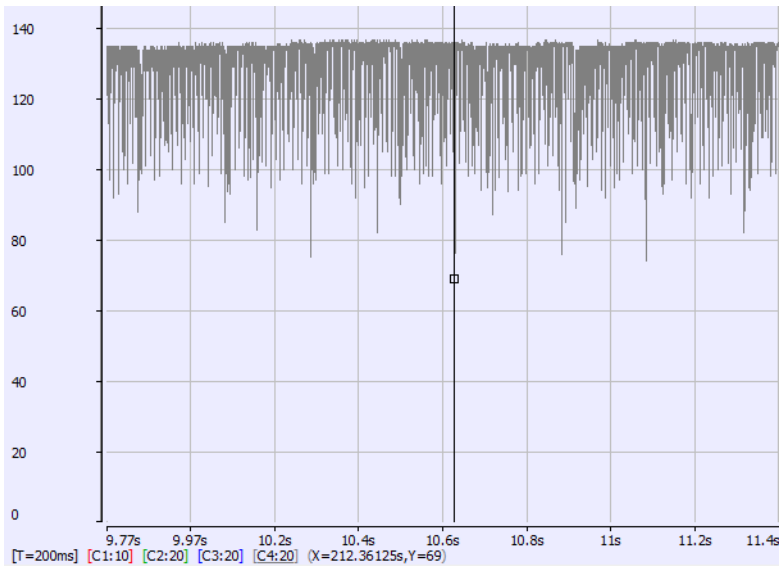

Figure 10-46: AKD PDMM / PDMM RealTimeMargin

PCMM2G

To view the minimum **PLCMarginTime**, configure the **Amplitude** and **Zero offset** so you can see the trace near zero.

In this example:

- The minimum (closest to zero) is 52 microseconds.
- This provides a 21% (52 / 250) **PLCMarginTime** (which is good).

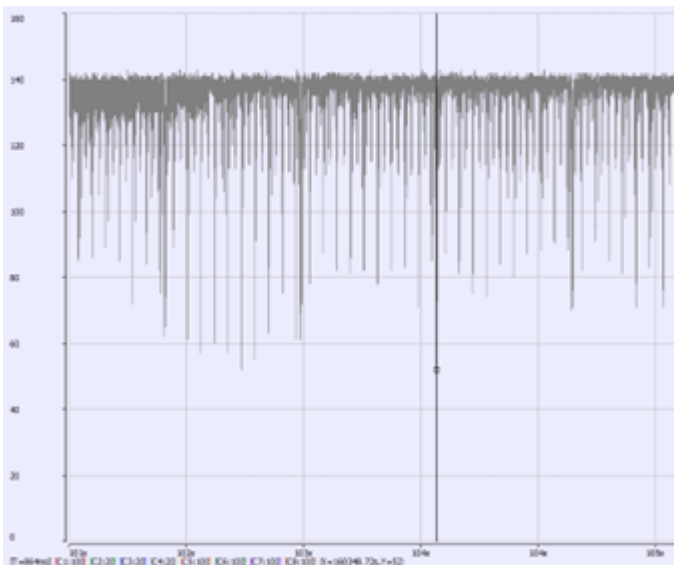

Figure 10-47: PCMM2G PLCMarginTime

9.5.10.2.2 CycleJitter Trace

For the **CycleJitter** trace configure the **Amplitude** and **Zero offset** so you can see the trace **centered** at zero.

- This trace is not too interesting unless a system is misbehaving.
- A jitter of +/- 15 microseconds is acceptable.

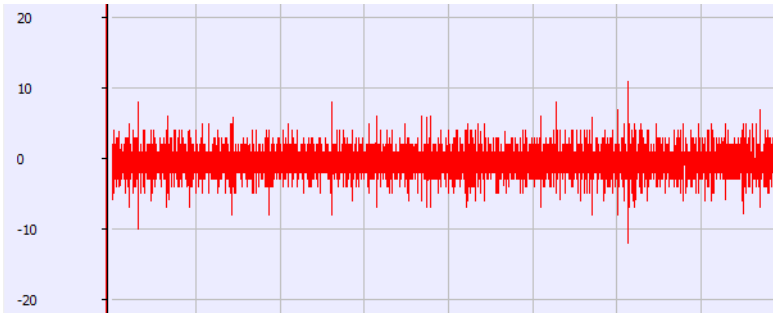

Figure 10-48: Cycle Jitter Trace

See Also

- "Example: AKD PDMM and PCMM Heavily Loaded CPU" (→ p. 504)
- "Example: AKD PDMM and PCMM Over Loaded CPU" (→ p. 506)
- "Example: PCMM2G Heavily Loaded CPU" (→ p. 508)
- "Example: PCMM2G Over Loaded CPU" (→ p. 510)

9.5.10.3 Example: AKD PDMM and PCMM Heavily Loaded CPU

This example shows an application that is heavily loading a AKD PDMM or PCMM with the EtherCAT Cycle Time = 250 microseconds.

Specifically, this example looks at:

- "1. MotionExec and PLCProgExec Times" (→ p. 504)
- "2. PLCProgExec Peaks" (→ p. 504)
- "3. RealTimeMargin" (→ p. 505)
- "4. Controller Log" (→ p. 505)
- "5. CPU Load" (→ p. 505)

9.5.10.3.1 1. MotionExec and PLCProgExec Times

Using the techniques described in "Practical Application: Using Trace Time To Measure CPU Load" (→ p. 499), examine the **MotionExec** and **PLCProgExec** times:

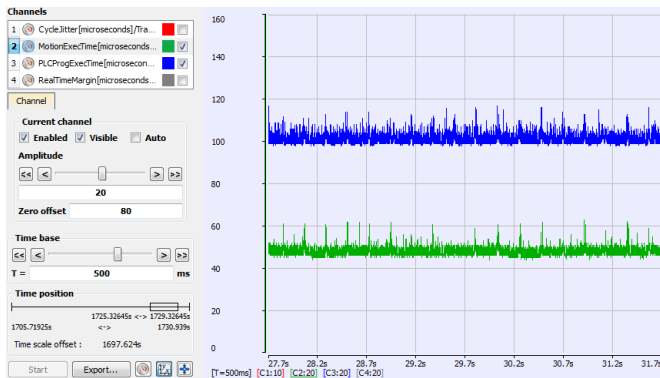

Figure 10-49: MotionExec and PLCProgExec Times

- The average **MotionExec** and **PLCProgExec** times are $50 + 105 = 155$ microseconds.
- This is 62% ($155 / 250$) of the cycle time.

9.5.10.3.2 2. PLCProgExec Peaks

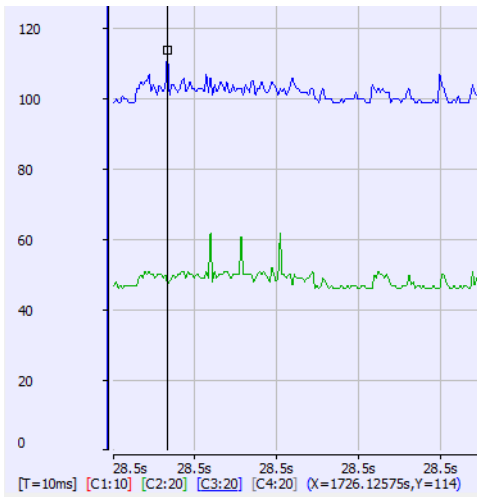

Figure 10-50: Peaks

This shows there is not much time left over:

- **MotionExec** = 62 microsec.
- **PLCProgExec** = 114.

9.5.10.3.3 3. RealTimeMargin

Next, look at the **RealTimeMargin**:

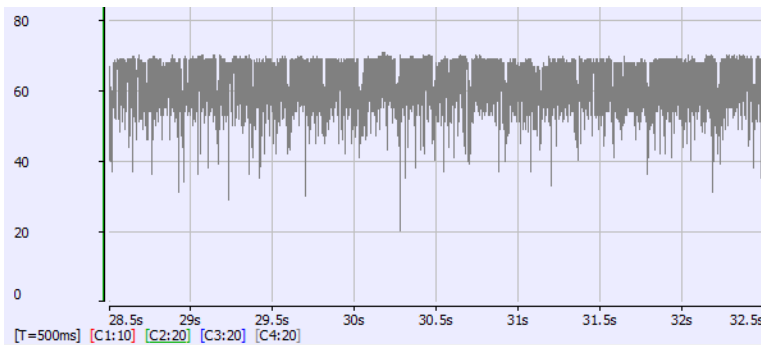

Figure 10-51: RealTimeMargin

- The minimum time is 20 microseconds.
 - This is 8% Real-Time margin (20 / 250).
- This is not a comfortable margin for deterministic Real-Time performance.

9.5.10.3.4 4. Controller Log

The Controller log shows that the Virtual Machine (**PLCProgExec**) is occasionally missing a cycle:

Time	Warning Icon	Time	Category	Level	Message
745	Warning	4/10/2012 10:37:22 AM (154)	Motion	WARNING	The Virtual Machine missed 1 cycle(s) of PLC execution.
746	Warning	4/10/2012 10:37:22 AM (654)	Motion	WARNING	The Virtual Machine missed 1 cycle(s) of PLC execution.
747	Warning	4/10/2012 10:37:23 AM (154)	Motion	WARNING	The Virtual Machine missed 1 cycle(s) of PLC execution.
748	Warning	4/10/2012 10:37:23 AM (654)	Motion	WARNING	The Virtual Machine missed 1 cycle(s) of PLC execution.
749	Warning	4/10/2012 10:37:24 AM (154)	Motion	WARNING	The Virtual Machine missed 1 cycle(s) of PLC execution.
750	Warning	4/10/2012 10:37:24 AM (583)	Motion	WARNING	The Virtual Machine missed 1 cycle(s) of PLC execution.
751	Warning	4/10/2012 10:37:25 AM (083)	Motion	WARNING	The Virtual Machine missed 1 cycle(s) of PLC execution.
752	Warning	4/10/2012 10:37:25 AM (583)	Motion	WARNING	The Virtual Machine missed 1 cycle(s) of PLC execution.
753	Warning	4/10/2012 10:37:26 AM (083)	Motion	WARNING	The Virtual Machine missed 1 cycle(s) of PLC execution.

Figure 10-52: Controller Log

9.5.10.3.5 5. CPU Load

Look at the overall **CPU load**.

- This is 88%.
 - There's not much CPU bandwidth available.

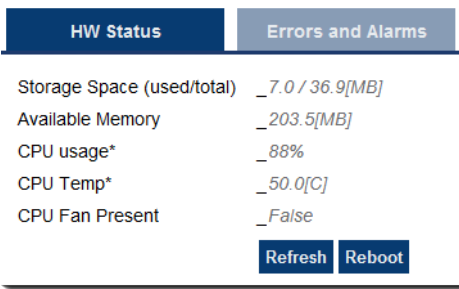

Figure 10-53: CPU load

See Also

- "Example: AKD PDMM and PCMM Over Loaded CPU" (→ p. 506)
- "Example: PCMM2G Heavily Loaded CPU" (→ p. 508)
- "Example: PCMM2G Over Loaded CPU" (→ p. 510)

9.5.10.4 Example: AKD PDMM and PCMM Over Loaded CPU

This example shows an application that is overloading an AKD PDMM or PCMM with the EtherCAT Cycle Time = 250 microseconds.

Specifically, this example looks at:

- "1. MotionExec and PLCProgExec Times" (→ p. 506)
- "2. RealTimeMargin" (→ p. 507)
- "3. Controller Log" (→ p. 507)
- "4. CPU Load" (→ p. 507)

9.5.10.4.1 1. MotionExec and PLCProgExec Times

Using the techniques described in "Practical Application: Using Trace Time To Measure CPU Load" (→ p. 499), examine the **MotionExec** and **PLCProgExec** times:

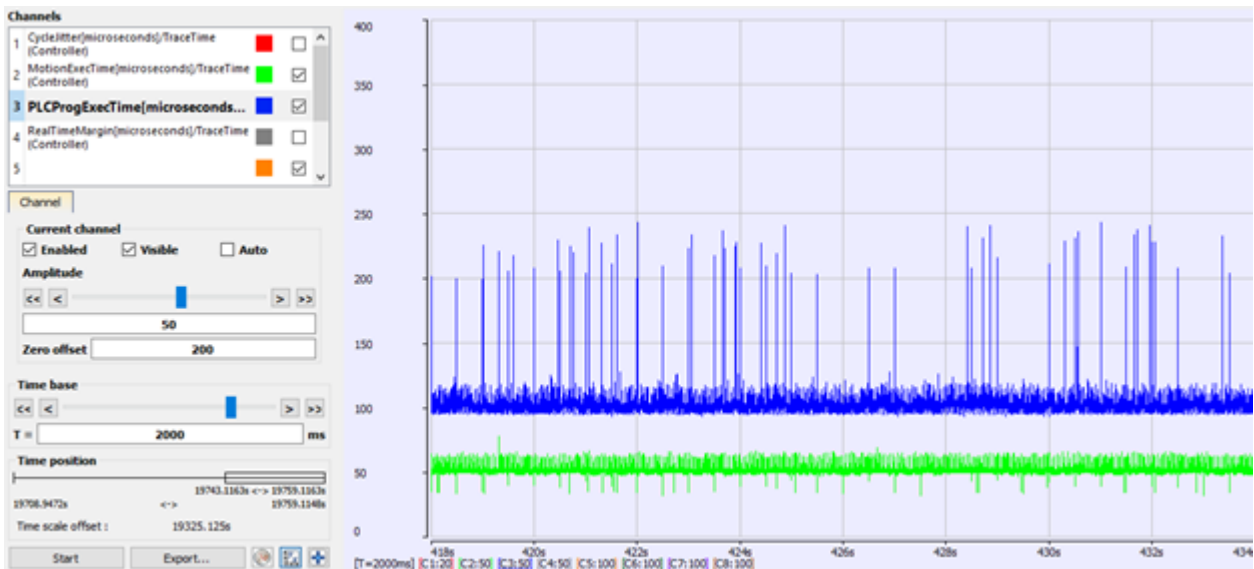

Figure 10-54: MotionExec and PLCProgExec Times

- The average **MotionExec** and **PLCProgExec** times are $57 + 110 = 167$ microseconds.
 - This is 67% ($167 / 250$) of the Cycle Time.

- Notice the big spikes on the **PLCProgExec**.
 - The PLC cannot complete all the programs within one cycle period.

9.5.10.4.2 2. RealTimeMargin



Figure 10-55: RealTimeMargin

- There is between 25 to 0 microseconds of margin.
- There are many cycles with zero real-time margin.
 - This example shows up to 1 second of no real time margin available.
- This is a degraded case.

9.5.10.4.3 3. Controller Log

The Controller log confirms the missing VM cycles and an "A23" (→ p. 681) alarm:

Information and Logs					
Local log Controller log Find and Replace Browse Variable Breakpoints Compiler Output					
Filter *					
		Time	Source	Level	Message
979	⚠	7/25/2023 2:05:03 PM (740)	Motion	WARNING	3 cycle(s) of PLC execution were missed in 2000 cycles.
980	⚠	7/25/2023 2:05:04 PM (240)	Motion	WARNING	5 cycle(s) of PLC execution were missed in 2000 cycles.
981	ℹ	7/25/2023 2:05:04 PM (240)	Motion	INFO	3 cycle(s) of PLC execution were missed to prevent CPU overload.
982	⚠	7/25/2023 2:05:04 PM (740)	Motion	WARNING	5 cycle(s) of PLC execution were missed in 2000 cycles.
983	⚠	7/25/2023 2:05:05 PM (240)	Motion	WARNING	4 cycle(s) of PLC execution were missed in 2000 cycles.
984	ℹ	7/25/2023 2:05:05 PM (240)	Motion	INFO	1 cycle(s) of PLC execution were missed to prevent CPU overload.
985	⚠	7/25/2023 2:05:05 PM (740)	Motion	WARNING	3 cycle(s) of PLC execution were missed in 2000 cycles.
986	⚠	7/25/2023 2:05:05 PM (797)	Controller	WARNING	UserInfo : Alarm A23 : CPU is heavily loaded
987	⚠	7/25/2023 2:05:07 PM (740)	Motion	WARNING	3 cycle(s) of PLC execution were missed in 2000 cycles.
988	ℹ	7/25/2023 2:05:07 PM (740)	Motion	INFO	1 cycle(s) of PLC execution were missed to prevent CPU overload.
989	⚠	7/25/2023 2:05:08 PM (240)	Motion	WARNING	1 cycle(s) of PLC execution were missed in 2000 cycles.
990	⚠	7/25/2023 2:05:08 PM (740)	Motion	WARNING	6 cycle(s) of PLC execution were missed in 2000 cycles.
991	ℹ	7/25/2023 2:05:08 PM (740)	Motion	INFO	2 cycle(s) of PLC execution were missed to prevent CPU overload.

Figure 10-56: Controller log

9.5.10.4.4 4. CPU Load

Look at the overall **CPU load**.

- This is 99%.
 - Clearly this application is overloading the CPU:

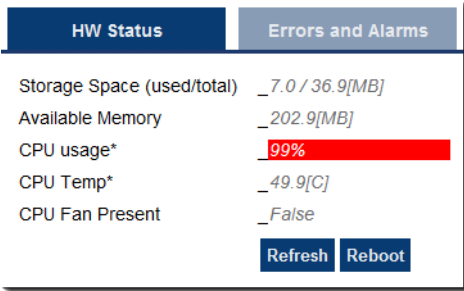

Figure 10-57: CPU load

See Also

- "Example: AKD PDMM and PCMM Heavily Loaded CPU" (→ p. 504)
- "Example: PCMM2G Heavily Loaded CPU" (→ p. 508)
- "Example: PCMM2G Over Loaded CPU" (→ p. 510)

9.5.10.5 Example: PCMM2G Heavily Loaded CPU

This example shows an application that is heavily loading a PCMM2G with the EtherCAT Cycle Time = 250 microseconds.

Specifically, this example looks at:

- "1. MotionExec and PLCProgExec Times" (→ p. 508)
- "2. PLCProgExec Peaks" (→ p. 509)
- "3. PLCMarginTime" (→ p. 509)
- "4. Controller Log" (→ p. 510)

9.5.10.5.1 1. MotionExec and PLCProgExec Times

Using the techniques described in "Practical Application: Using Trace Time To Measure CPU Load" (→ p. 499), examine the **MotionExec** and **PLCProgExec** times:

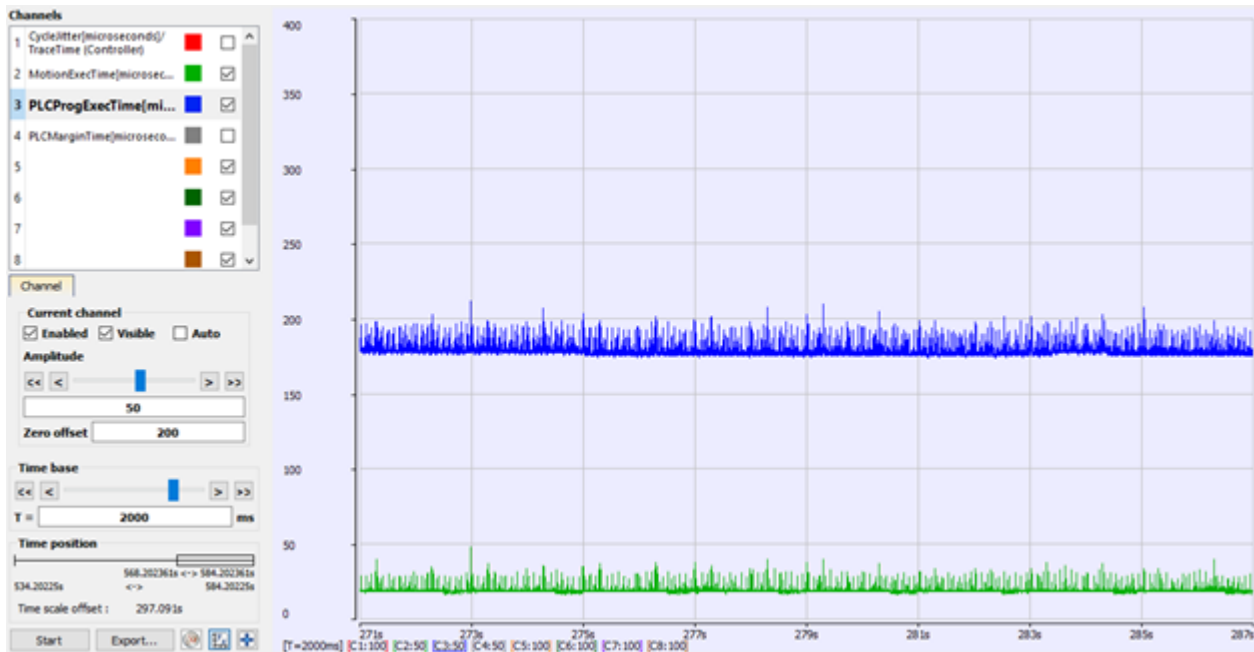

Figure 10-58: MotionExec and PLCProgExec Times

- The average **MotionExec** = 20 microseconds.
 - This is about 8% (20 / 250) of the cycle time.
- The average **PLCProgExec** = 178 microseconds.
 - This is about 71% (178 / 250) of the cycle time.
- Thus, the PLC programs have a much higher load.

9.5.10.5.2 2. PLCProgExec Peaks

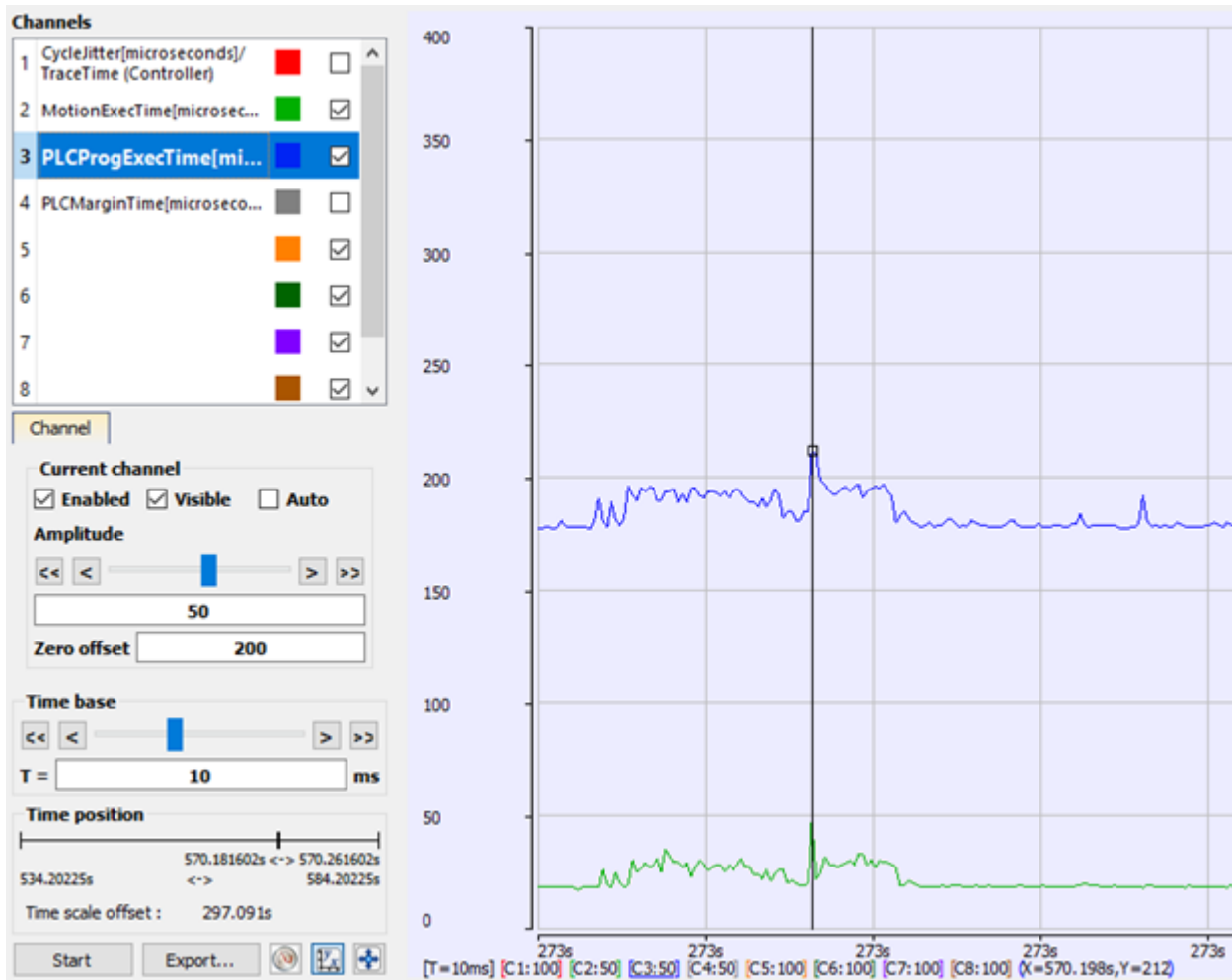

Figure 10-59: PLCProgExec Peaks

This shows there is not much time left over:

- **PLCProgExec** = 212.

9.5.10.5.3 3. PLCMarginTime

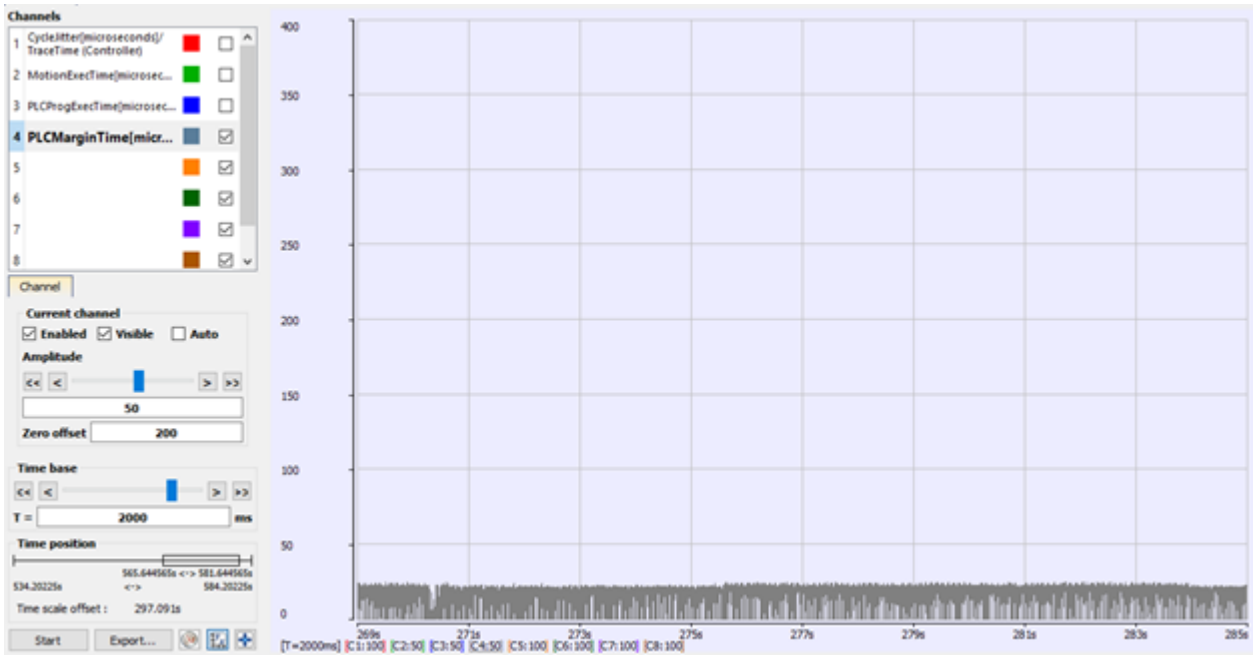

Figure 10-60: PLCMarginTime

- The **PLCMarginTime** is between 0 and 25 microseconds (0% to 10%).
- This is not a comfortable margin for deterministic PLC performance.

9.5.10.5.4 4. Controller Log

The Controller log confirms the occasionally missing PLC execution cycles:

Information and Logs						
Local log		Controller log	Find and Replace	Browse Variable	Breakpoints	Compiler Output
Filter *						
		Time	Source	Level	Message	
24	⚠	7/25/2023 9:52:37 PM (131)	Motion	WARNING	1 cycle(s) of PLC execution were missed in 2000 cycles.	
25	⚠	7/25/2023 9:52:44 PM (132)	Motion	WARNING	1 cycle(s) of PLC execution were missed in 2000 cycles.	
26	⚠	7/25/2023 9:52:47 PM (132)	Motion	WARNING	1 cycle(s) of PLC execution were missed in 2000 cycles.	
27	⚠	7/25/2023 9:52:50 PM (632)	Motion	WARNING	1 cycle(s) of PLC execution were missed in 2000 cycles.	
28	⚠	7/25/2023 9:52:55 PM (632)	Motion	WARNING	7 cycle(s) of PLC execution were missed in 2000 cycles.	
29	⚠	7/25/2023 9:52:59 PM (132)	Motion	WARNING	1 cycle(s) of PLC execution were missed in 2000 cycles.	
30	⚠	7/25/2023 9:53:03 PM (132)	Motion	WARNING	1 cycle(s) of PLC execution were missed in 2000 cycles.	
31	⚠	7/25/2023 9:53:04 PM (632)	Motion	WARNING	1 cycle(s) of PLC execution were missed in 2000 cycles.	
32	⚠	7/25/2023 9:53:11 PM (132)	Motion	WARNING	1 cycle(s) of PLC execution were missed in 2000 cycles.	

Figure 10-61: Controller Log

See Also

- "Example: AKD PDMM and PCMM Heavily Loaded CPU" (→ p. 504)
- "Example: AKD PDMM and PCMM Over Loaded CPU" (→ p. 506)
- "Example: PCMM2G Over Loaded CPU" (→ p. 510)

9.5.10.6 Example: PCMM2G Over Loaded CPU

This example shows an application that is overloading a PCMM2G with the EtherCAT Cycle Time = 250 microseconds.

Specifically, this example looks at:

- "1. MotionExec and PLCProgExec Times" (→ p. 511)
- "2. RealTimeMargin" (→ p. 511)
- "3. Controller Log" (→ p. 512)

9.5.10.6.1 1. MotionExec and PLCProgExec Times

Using the techniques described in "Practical Application: Using Trace Time To Measure CPU Load" (→ p. 499), examine the **MotionExec** and **PLCProgExec** times:

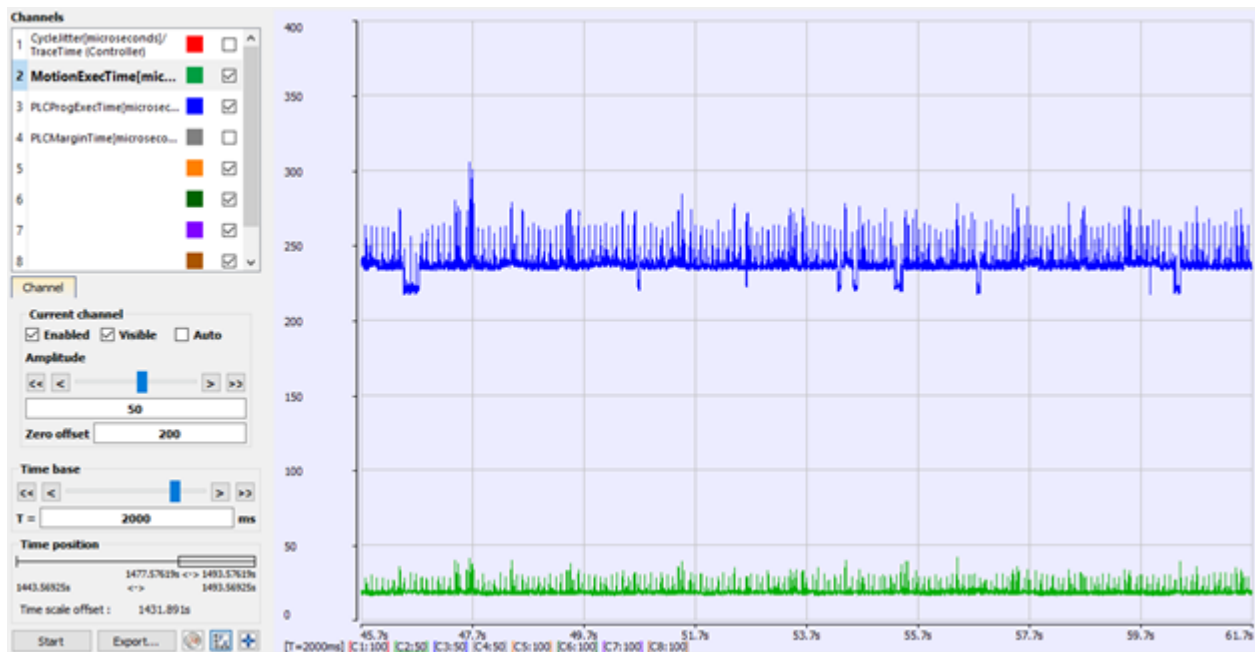

Figure 10-62: MotionExec and PLCProgExec Times

- The average **MotionExec** = 20 microseconds.
 - This is about 8% (20 / 250) of the cycle time.
- The average **PLCProgExec** = 235 microseconds.
 - This is about 94% (235 / 250) of the cycle time.

9.5.10.6.2 2. RealTimeMargin



Figure 10-63: RealTimeMargin

- The **PLCMarginTime** is zero.
- There is not enough time to complete the PLC programs every cycle.

9.5.10.6.3 3. Controller Log

The Controller log confirms the missing PLC execution cycles:

Information and Logs					
Local log Controller log Find and Replace Browse Variable Breakpoints Compiler Output					
Filter *					
		Time	Source	Level	Message
79	⚠	7/25/2023 10:08:20 PM (647)	Motion	WARNING	97 cycle(s) of PLC execution were missed in 2000 cycles.
80	⚠	7/25/2023 10:08:21 PM (147)	Motion	WARNING	99 cycle(s) of PLC execution were missed in 2000 cycles.
81	⚠	7/25/2023 10:08:21 PM (647)	Motion	WARNING	70 cycle(s) of PLC execution were missed in 2000 cycles.
82	⚠	7/25/2023 10:08:22 PM (147)	Motion	WARNING	133 cycle(s) of PLC execution were missed in 2000 cycles.
83	⚠	7/25/2023 10:08:22 PM (647)	Motion	WARNING	89 cycle(s) of PLC execution were missed in 2000 cycles.
84	⚠	7/25/2023 10:08:23 PM (147)	Motion	WARNING	111 cycle(s) of PLC execution were missed in 2000 cycles.
85	⚠	7/25/2023 10:08:23 PM (647)	Motion	WARNING	118 cycle(s) of PLC execution were missed in 2000 cycles.
86	⚠	7/25/2023 10:08:24 PM (147)	Motion	WARNING	135 cycle(s) of PLC execution were missed in 2000 cycles.
87	⚠	7/25/2023 10:08:24 PM (647)	Motion	WARNING	75 cycle(s) of PLC execution were missed in 2000 cycles.

Figure 10-64: Controller log

- The PCMM2G controller CPU core has plenty of time to execute the Motion Engine and Axes.
 - However, the CPU core running the PLC cannot complete within one Motion/EtherCAT cycle.
- The PLC programs are spanning multiple Motion/EtherCAT cycles.
 - This may cause trouble for application programs that rely on Motion and EtherCAT data updated every PLC cycle.

See Also

- "Example: AKD PDMM and PCMM Heavily Loaded CPU" (→ p. 504)
- "Example: AKD PDMM and PCMM Over Loaded CPU" (→ p. 506)
- "Example: PCMM2G Heavily Loaded CPU" (→ p. 508)

10 Advanced Topics

10.1 Coordinated Motion

This section provides an overview of Coordinated Motion, including general concepts to understand and use Coordinated Motion.

- Group State Diagrams
- Coordinate Systems
- Glossary and Acronyms proxy

See Create a Linear or Circular Coordinated Motion Application.

Coordinated motion in KAS-IDE is discussed in several locations and manners.

- Design Coordinated Motion - Use this section to get started quickly with coordinated motion by walking you through the steps of setting up a project that uses coordinated motion.
- Motion / Common - Coordinated Motion - Use this reference section for function block parameters.

NOTE

The coordinated motion library supports coordinated motion for a maximum of 128 axes. Hardware limitations may impose a lower limit for most applications.

10.1.1 Group State Diagrams

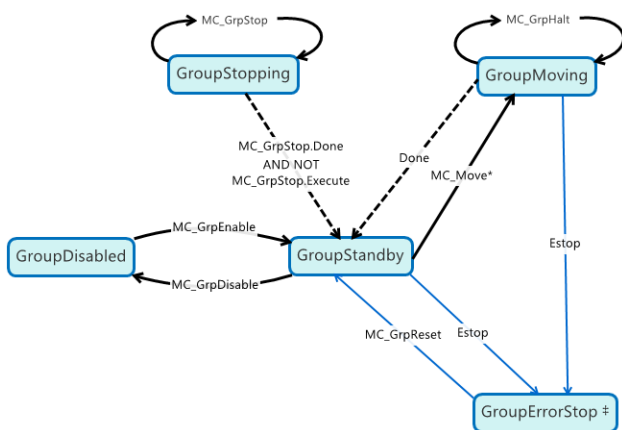

A limitation exists where a single axis ErrorStop condition does not change the AxesGroup state to GroupErrorStop.

10.1.2 Coordinate Systems

These are the different coordinate system (CS) types:

- Machine (MCS)
- Axes (ACS)
- Product/Program (PCS)

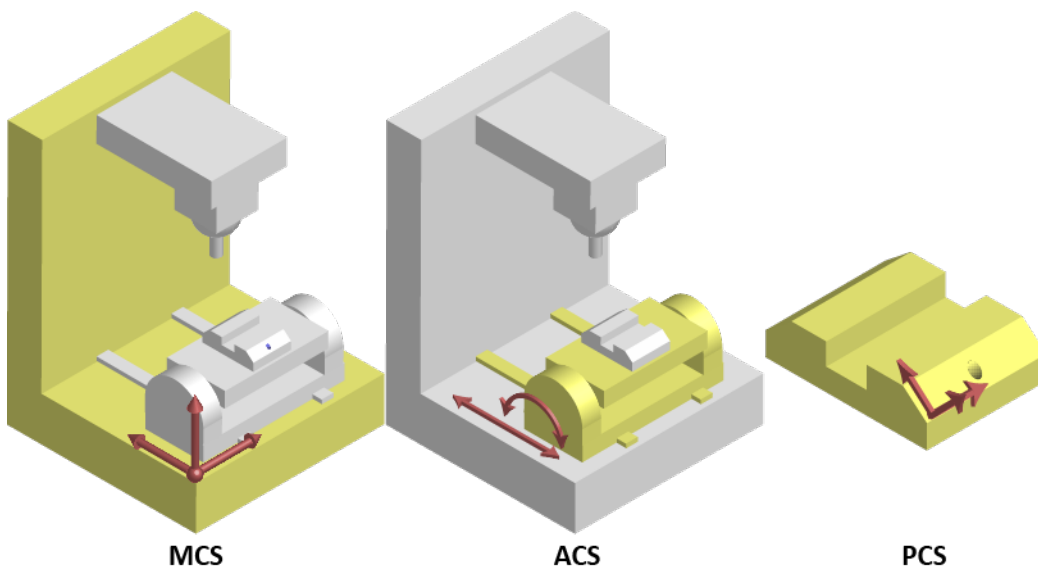
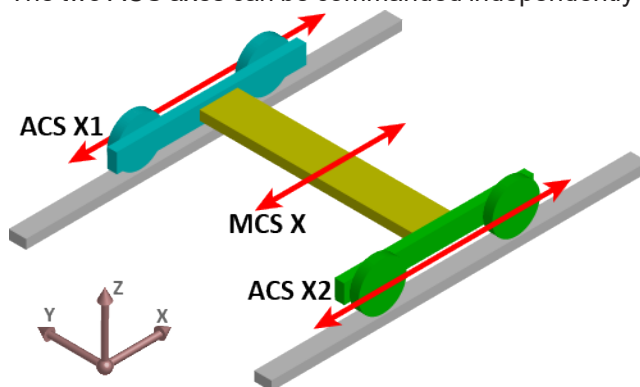

Figure 11-1: Examples of CS types on a machine and part.

- Many coordinated moves may be done in a choice of coordinate systems.
- The differences between the types are offsets and possibly transformational algorithms to convert between the different systems, which ultimately control the actual axes on a piece of machinery.

Example

- The X-axis of a Machine CS is meant to command a pair of Axes CS axes (X1 and X2) which together form a gantry.
- The relative movement of the MCS X axis would be added to both ACS axes.
- The two ACS axes can be commanded independently for minor alignment adjustments.



TIP

The Product Coordinate System is often rotated and/or offset from the Machine Coordinate System.

10.1.3 Design Coordinated Motion

These topics show how to create a coordinated motion application, including adding coordinated motion to existing applications.

- "Blending Between Moves" (→ p. 516)
- "Blending with Transitions" (→ p. 517)
- "Create a Linear or Circular Coordinated Motion Application" (→ p. 518)
- "Differences between MC_GrpHalt and MC_GrpStop" (→ p. 527)
- "Handling Axis Errors" (→ p. 533)
- "Transition Between Moves" (→ p. 535)

See Also

- "Coordinated Motion" (→ p. 514)
- Coordinated Motion Function Blocks

10.1.3.1 Blending Between Moves



Some Coordinated Motion function blocks have a **BufferMode** input parameter.



Buffer modes include:

- BM_ABORTING = 0 = Aborting
- BM_BUFFERED = 1 = Buffered
- BM_BLENDED_PREVIOUS = 2 = Blending Previous
- BM_BLENDED_NEXT = 3 = Blending Next
- BM_BLENDED_LOW = 4 = Blending Low
- BM_BLENDED_HIGH = 5 = Blending High

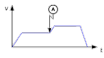
When the current and next motion function blocks are blended (2 through 5), the axes group does not stop between motions.

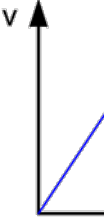
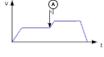
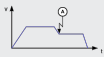
- The velocity is blended according to the specified blending mode.
- The function block's **TransitionMode** parameter can be set to provide a smooth circular arc between moves.
- See "Transition Between Moves" (→ p. 535).

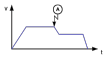
Buffer Mode	Profile	Description
BM_ABORTING		<p>In the image, the second function block starts execution at Point A.</p> <ul style="list-style-type: none"> • The current move stops execution immediately. • The next move becomes active and begins to accelerate or decelerate from the current velocity to its programmed velocity.
BM_BLENDED_HIGH	 	<p>In the image, the second function block starts execution at Point A. The velocity is blended to the highest velocity of the two moves.</p> <ul style="list-style-type: none"> • If the current move's velocity is higher than the next move's velocity, Blending Previous is used. • If the next move's velocity is higher than the current move's velocity, Blending Next is used.
BM_BLENDED_LOW	 	<p>In the image, the second function block starts execution at Point A. The velocity is blended to the lowest velocity of the two moves.</p> <ul style="list-style-type: none"> • If the current move's velocity is lower than the next move's velocity, Blending Previous is used. • If the next move's velocity is lower than the current move's velocity, Blending Next is used.
BM_BLENDED_NEXT		<p>In the image, the second function block starts execution at Point A. The current move begins to accelerate or decelerate so that it reaches the next move's programmed velocity at the time the current move reaches its endpoint.</p>





Buffer Mode	Profile	Description
BM_BLENDING_PREVIOUS		<p>In the image, the second function block starts execution at Point A.</p> <ul style="list-style-type: none"> The current move stays at its programmed velocity to its endpoint. When the current move reaches its endpoint, the next move becomes active and begins to accelerate or decelerate to its programmed velocity.
BM_BUFFERED		<p>In the image, the second function block starts execution at Point A.</p> <ul style="list-style-type: none"> The current move completes as was originally specified, coming to a stop. When the current move reaches its endpoint, the next move becomes active and begins to accelerate to its programmed velocity.

10.1.3.2 Blending with Transitions

When blending and a transition are specified, the buffer mode is used to blend velocities of path segments when the path changes from the incoming segment to the transition segment and from the transition segment to the outgoing segment.

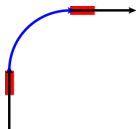
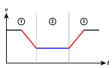
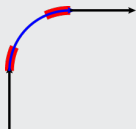
Notes

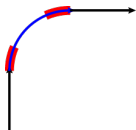
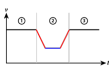
- S-Curve Corner transitions only support blending buffer modes.
 - All blending moves are treated the same when using S-Curve Corner transitions since the transition includes blending.
 - See "S-Curve Corner Line-to-Line Transitions" (→ p. 543).
- The most common blending mode choices for applications are listed in the table.
 - This shows the velocity profile and where acceleration occurs on the path.
 - In the examples:
 - Blue** = Transition arc.
 - Red** = Where the acceleration occurs.
 - 1 = Incoming move.
 - 2 = Transition.
 - 3 = Outgoing move.

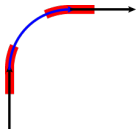
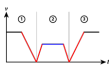
Buffer Mode	Example	Profile
BM_BLENDING_LOW When the transition velocity is smaller than the incoming and outgoing move velocities.		
BM_BLENDING_LOW When the transition velocity is larger than the incoming and outgoing move velocities.		
BM_BLENDING_HIGH When the transition velocity is smaller than the incoming and outgoing move velocities.		
BM_BLENDING_HIGH When the transition velocity is larger than the incoming and outgoing move velocities.		
BM_BUFFERED		

10.1.3.3 Create a Linear or Circular Coordinated Motion Application

A Coordinated Motion application can be created in one of these ways:

- Use a Coordinated Motion template to create a new application.
 - Two Coordinated Motion templates are currently available.
 - The first template controls two PLCopen axes in coordinated motion.
 - The second template controls two PLCopen axes in coordinated motion plus a third independent Pipe Network axis.
- Modify an existing application to include coordinated motion functions.
 - When modifying an existing application, axes need to be grouped to define the axes that will be active when performing coordinated motion on that group.
 - See "What are Axes Groups?" (→ p. 521).

NOTE

Coordinated motion can only be performed with PLCopen axes.

Pipe Network axes do not support this feature.

Pipe Network axes can be moved independently from coordinated motion groups.

Any synchronization between coordinated motion and Pipe Network axes must be performed by the PLC application.

10.1.3.3.1 Groups

- Related axes are grouped in an axes group.
- Coordinated motion is then performed on an axes group.
- See "What are Axes Groups?" (→ p. 521).

TIP

Remember these vital concepts when making interpolated motion.

- Interpolated motion requires creating a motion group that results in a second group coordinate system.
- Group coordinate system positions are only affected by group motion.
- Non-group coordinate system positions are only affected by non-group motion.

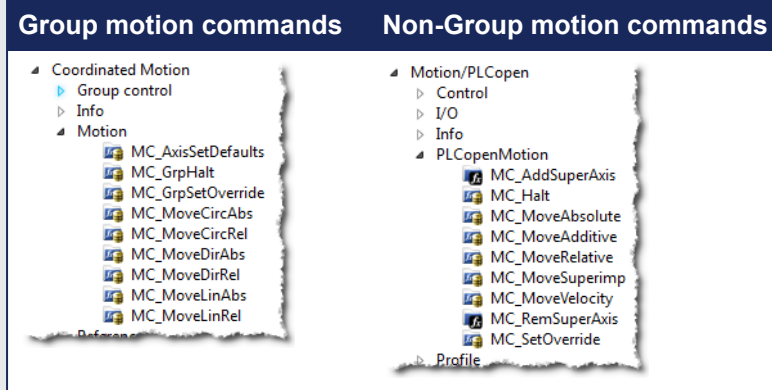

NOTE

Axes that become part of a motion group are first homed using non –group function blocks to establish a home or starting position for the group motion.

10.1.3.3.2 Function Block Calls

These function blocks should be called before executing coordinated motion.

1. Call `MLMotionInit (BasePeriod)` to initialize the motion engine.
Base period is specified in microseconds.

```
MLMotionInit(1000.0); // 1000 µSec -> 1 mSec
```

- Call `MC_CreateAxesGrp` (Enable, GroupName, UpdateRate, MaxNumberOfAxes, AxesGroupRef) to create a Coordinated Motion Axes Group.

NOTE

`MC_CreateAxesGrp` must be called between `MLMotionInit()` and `MLMotionStart()`.

```
Inst_MC_CreateAxesGrp(TRUE, 'GROUP1', 6, 2, Group1_ref);
```

In this example, the axes group name is **GROUP1**, the update rate is 1 mSec (specified by '6') and the maximum number of axes that can be added to the group is 2.

The group reference variable **Group1_ref** is used in future coordinated motion function block calls to reference this newly created group.

- Call `MC_InitAxesGrp` (Enable, AxesGroup, VelLimit, AccLimit, DecLimit, JerkLimit) to initialize the path limits for velocity, acceleration, deceleration, and jerk.

```
Inst_MC_InitAxesGrp(TRUE, Group1_ref, 100.0, 300.0, 300.0, 1000.0);
```

In this example, the kinematic limits for axes group **Group1_ref** is set.

The velocity limit is set to 100.0 user units/second.

Acceleration and deceleration limits are set to 300.0 User unit/sec².

Jerk is set to 1000.0 User unit/sec³.

- Call `MC_CreatePLCAxis` (AxisName, BusInterface, BusAddress, AxisNumber, AxisType, UserUnits, FeedbackUnits, Rollover, UpdateRate) to create a Coordinated Motion Axis. This function must be called for each Coordinated Motion Axis wanted in the application.

NOTE

`MC_CreatePLCAxis` needs to be called between `MLMotionInit()` and `MLMotionStart()`.

```
Inst_MC_CreateAxis(TRUE, 'CoordAxis1', 'EtherCATDriver', 1001, CoordAxis1_AxisNum, 0, 360, 1048576, 0, 6);
Inst_MC_CreateAxis(TRUE, 'CoordAxis2', 'EtherCATDriver', 1002, CoordAxis2_AxisNum, 0, 360, 1048576, 0, 6);
```

In this example:

- Two axes are created and are named **CoordAxis1** and **CoordAxis2**.
 - The bus interface for both is **EtherCATDriver**.
 - The address of the drive on the bus is 1001 and 1002.
 - The axis numbers are set with variables `CoordAxis1_AxisNum` and `CoordAxis2_AxisNum` which is set to an integer value between 1 and 256.
 - Each axis number is unique.
 - The axis type for both, 0, indicates a servo axis.
 - The user units are 360, which is the user unit portion of the user unit/feedback ratio.
 - The feedback units are 1048576.
 - This is the feedback portion of the user unit/feedback ratio.
 - The rollover position for both, 0, indicates no rollover.
 - The update rate for both, 6, indicates a 1mSec update rate.
- Call `MLMotionStart()` to start the Motion and the motion bus driver. This also initializes the EtherCAT network to operational mode.

```
MLMotionStart();
```

- Call `MC_AddAxisToGrp` (Execute, AxesGroup, Axis, IdentInGroup) for each axis to add to the group.

```
Inst_MC_AddAxisToGrp(TRUE, Group1_ref, CoordAxis1_ref, 0);
Inst_MC_AddAxisToGrp(TRUE, Group1_ref, CoordAxis2_ref, 1);
```

In this example, we are adding two axes, CoordAxis1 and CoordAxis2, to the group referenced by **Group1_ref**.

The axes are stored in the IdentInGroup positions 0 and 1.

When the group was created, it was specified that no more than 2 axes will be part of this group.

Therefore, valid IdentInGroup locations are 0 and 1.

7. Call MC_Power (Enable, Axis, EnablePositive, EnableNegative, BufferMode) for each Coordinated Motion Axis to enable the drive and close the servo loop.

```
Inst_MC_Power1(TRUE, CoordAxis1_ref, TRUE, TRUE, 0);
Inst_MC_Power2(TRUE, CoordAxis2_ref, TRUE, TRUE, 0);
```

In this example, drives CoordAxis1_ref and CoordAxis2_ref are enabled and the position loop is closed.

8. Call MC_GrpEnable (Execute, AxesGroup) to change the state of the Coordinated Motion Axis Group from GroupDisabled to GroupStandby and allow motion to be performed on the group.

```
Inst_MC_GrpEnable(TRUE, Group1_ref);
```

In this example, **Group1_ref** state is changed from GroupDisabled to GroupStandby.

The group must be in GroupStandby to perform the motion.

9. In these examples, we want to set the current location of the axes in the group to 0, 0. This is done by calling MC_GrpSetPos (Execute, AxesGroup, Position[], Relative, CoordSystem, BufferMode).

```
PosAbs[1] := 0;
PosAbs[2] := 0;
Inst_MC_GrpSetPos(TRUE, Group1_ref, PosAbs, 0, MC_COORDINATE_SYSTEM_ACS, 0);
```

In this example, the axis positions of **Group1_ref** is set to 0, 0.

PosAbs specifies the position for each axis in the group.

Relative input, 0, uses PosAbs to set the absolute position.

The coordinate system is set to ACS.

NOTE

No motion is performed when this function block is executed.

10. **Optional:** To Add more axes to the group, change the code this way:
 - In Step 2: Update the MaxNumberOfAxes input argument so that the group can handle the desired number of axes.
 - In Step 4: Create the additional axes to add to the group.
 - In Step 6: Add the additional axes to the group.
 - In Step 7: Power on the additional axes.
 - In Step 9: Increase the size of the PosAbs array so it matches the number you used in step 2. Set the position of the additional axes to zero.

After the above function calls have been made, we can start coordinated motion moves.

See Also

- "Perform a Linear Move" (→ p. 525)
- "Perform a Circular Move" (→ p. 521)

10.1.3.3.3 What are Axes Groups?

Related axes are grouped in an Axes Group to support interpolation. Axes Groups are accessed using the type `AXES_GROUP_REF`.

This image shows the relationships between the different CSs and groups.

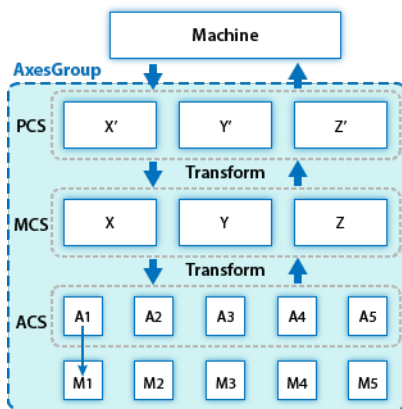

Figure 11-2: Overview of AxesGroup

The Axes Group, shown in blue, provides the interface to the user of the group of axes.

To access the relevant coordinate system, the relevant function blocks have an input Coordinate System which supports the three levels ACS, MCS, and PCS.

Parameters in the AxesGroupRef can include remaining time and remaining distance before target position (or velocity or equal) is reached.

10.1.3.3.4 Perform a Circular Move

Circular moves can be programmed using absolute or relative positions using the following function blocks:

- `MC_MoveCircAbs` which commands interpolated circular movement on an axes group to the specified absolute positions.
- `MC_MoveCircRel` which commands interpolated circular movement on an axes group to the specified relative positions.

Prior to performing any coordinated moves, some setup is needed.

- See "Create a Linear or Circular Coordinated Motion Application" (→ p. 518).
- Once these steps have been performed, a circular move can be performed.

In these examples, two circular moves are performed:

- "Absolute Circular Move" (→ p. 521)
- "Relative Circular Move" (→ p. 522)

10.1.3.3.5.1 Absolute Circular Move

In this move, an absolute circular move goes from (0, 0) to (90, 90).

- `CircMode` specifies that the aux point (0, 180) is crossed during the paths start to end.
- Call `MC_MoveCircAbs`.

```
PosCircAuxAbs[0] := 0; // A point on the circle that is crossed on
the
PosCircAuxAbs[1] := 180; // path from start to end point.
PosCircEndAbs[0] := 90; // Absolute end point.
PosCircEndAbs[1] := 90;
```

```
Inst_MC_MoveCircAbs(TRUE, Group1_ref, CIRC_MODE_BORDER, PosCircAuxAbs,
PosCircEndAbs, CIRC_PATH_CLKWISE, MaxVel, MaxAcc, MaxDec, 0, CS_ACS, BM_
BUFFERED, TM_NONE, TransParam);
```

In the example, a circular move is performed on axis group **Group1_ref**.

- CircMode is defined as CIRC_MODE_BORDER.
 - This mode indicates that the AuxPoint array input indicates a point on the circle which is crossed on the path from the starting point to the end point.
 - See "Circular Moves Diagrams" (→ p. 523) about CircMode movement options.
- The AuxPoint array, **PosCircAuxAbs**, defines an absolute point on the circle which is crossed on the path from the starting point to the end point.
 - The contents of this array are determined by the CircMode variable CIRC_MODE_BORDER.
- The EndPoint array, **PosCircEndAbs**, contains the absolute end point for each axis in the group.
 - The absolute end point of the axis stored in position 0 (IdentInGroup) of the group is 90.0.
 - The absolute end point of the axis stored in position 1 of the group is 90.0.
- PathChoice is only relevant when CircMode is set to CIRC_MODE_CENTER.
 - In this case, this parameter is not used.
- The maximum velocity is specified by variable **MaxVel** and is specified in User unit/sec.
- The maximum acceleration and deceleration are specified by variables **MaxAcc** and **MaxDec** and are specified in User unit/sec².
- The maximum jerk is not supported and can be set to a value of 0.
- The coordinate system is ACS.
- The BufferMode is set to BM_BUFFERED, indicating the move is buffered.
 - See "Buffer Modes" (→ p. 769) for detailed information.
- The TransitionMode is set to TM_NONE, indicating no transition mode is used.
 - See "Transition Between Moves" (→ p. 535).
- The TransParam array is required.
 - The contents can be set to 0 because the transition mode is not being used.
 - The TransParam array is a 2-element array containing the corner distance and velocity for the transition.

10.1.3.3.6.2 Relative Circular Move

This is a relative circular move whose end point is (90, 90) from the end of the first move.

- CircMode specifies that the aux point (0, 90) is the relative center of the circle.
- The BufferMode input is set to **Buffered**; this move waits for the first move to complete before it begins executing.
- Call MC_MoveCircRel.

```
PosCircAuxRel[0] := 0; // Relative center of the circle.
PosCircAuxRel[1] := 90;
PosCircEndRel[0] := 90; // Relative end point.
PosCircEndRel[1] := 90; // Start pt 90,90 + rel 90,90 -> 180,180
absolute end pt

Inst_MC_MoveCircRel(TRUE, Group1_ref, CIRC_MODE_CENTER, PosCircAuxRel,
PosCircEndRel, CIRC_PATH_CLKWISE, MaxVel, MaxAcc, MaxDec, 0, CS_ACS, BM_
BUFFERED, TM_NONE, TransParam);
```

In the example, all the variables have the same meaning as the circular absolute example except:

- CircMode is defined as CIRC_MODE_CENTER.
 - This mode indicates that the AuxPoint array input indicates the center point of the circle.
 - See "Circular Moves Diagrams" (→ p. 523) about CircMode movement options.
- The AuxPoint array, **PosCircAuxRel**, defines the relative center point of the circle.
 - The contents of this array are determined by the CircMode variable, CIRC_MODE_CENTER.
- The EndPoint array, **PosCircEndRel**, contains the relative end point for each axis in the group.
 - The relative end point of the axis stored in position 0 (IdentInGroup) of the group is 90.0.
 - The relative end point of the axis stored in position 1 of the group will be 90.0.
- PathChoice is relevant when CircMode is set to CIRC_MODE_CENTER.
 - In this case, PathChoice is CIRC_PATH_CLKWISE which specifies the direction of the path.

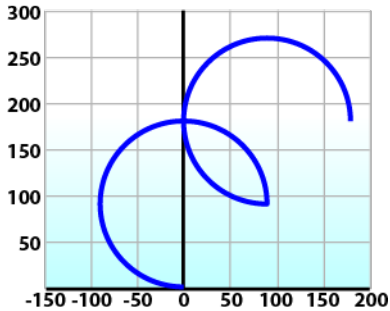

10.1.3.3.7.3 Circular Moves Diagrams

10.2 CircMode = BORDER

- The user defines the end point and a border point (= input AuxPoint) on the sector of the circle which the machine will traverse.
- For Relative mode, both points are defined relative to the starting point.
- Advantage
 - The border point can usually be reached by the machine, i.e., it can be taught.
- Disadvantage
 - Restricted to angles < 360° in one single command.

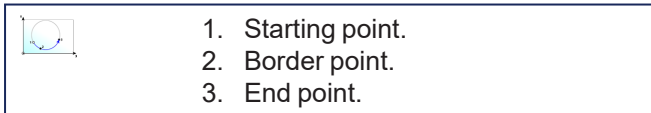

10.3 CircMode = CENTER

- The user defines the end point and center point (= input AuxPoint) of the circle.
- The input PathChoice defines clockwise or counter-clockwise motion.
- For Relative mode, both points are defined relative to the starting point.
- Advantage
 - Full 360° moves are possible.
- Disadvantages
 - Cannot perform zero-distance moves.
 - Over-determination of the circle equation.

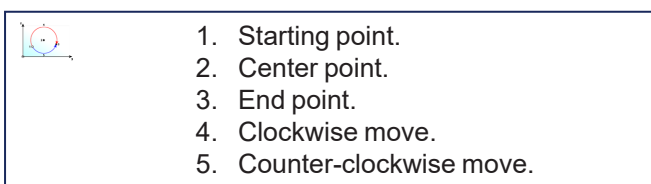

A 360° move is performed if the end point is the same as the start point.

	<ol style="list-style-type: none"> 1. Starting and Ending point. 2. Center point. 3. Clockwise move. 4. Counter-clockwise move.
---	---

10.3.0.0.1.1 Precision Requirements for Circular Move Input Parameters

The input parameters to MC_MoveCircAbs and MC_MoveCircRel are validated when constructing a circle.

- The distance of the center point from the start and end points is checked.
- Ideally, the two distances are the same but calculation errors or input data precision can cause the two distances to be slightly different.
- If the validation fails, PLCopen error 50 (Cannot construct a circle with specified parameters) is returned from the function block.

10.4 Parameter Validation

Input parameters are validated using these methods:

See "PLCopen Function Block ErrorIDs" (→ p. 744).

Here is a circle we want to create.

The distances from the center to the start and end point are measured as r_1 and r_2 respectively.

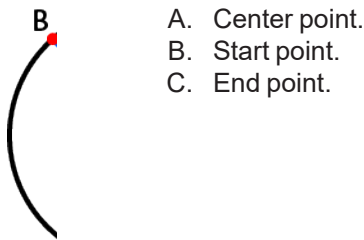

The methods for validating the circle parameters are:

- "Default Validation Method" (→ p. 524)
- "Validation with Custom Tolerance" (→ p. 525)

NOTE

If MC_GRP_PARAM_CIRCLE_TOLERANCE is set to zero (0), the default validation method will be used.

10.5 Default Validation Method

- The difference between the two measurements must not be larger than one part in 100,000.
- If all positions are specified to six significant digits, this requirement is met.
- Assuming that r_2 is greater than r_1 , we can write r_2 in terms of r_1 and a small deviation value named ϵ :

$$r_2 = r_1(1 + \epsilon)$$

- If ϵ exceeds a value of 10⁻⁵, the validation fails.
- A PLCopen error 50 is returned from the function block.

Examples of Default Validation

If the desired circle has a radius of:

- 50 user units, the center must be specified with a precision of 0.0005 user units.
- 2,000 user units, the center must be specified with a precision of 0.02 user units.
- 500,000 user units, the center must be specified with a precision of 5 user units.

10.6 Validation with Custom Tolerance

A custom tolerance can be specified via the group parameter MC_GRP_PARAM_CIRCLE_TOLERANCE.

- See "Axes Group Parameters" (→ p. 748).
- This parameter represents the amount of error allowed, measured in user units.
- The parameter can be set by using MC_GrpWriteParam and can be read via MC_GrpReadParam.
- Assuming that r_2 is greater than r_1 , we can write r_2 in terms of r_1 and a deviation value named Δ :

$$r_2 = r_1 + \Delta$$

- The validation fails if Δ exceeds the value of the group parameter MC_GRP_PARAM_CIRCLE_TOLERANCE.
- A PLCOpen error 50 is returned from the function block.

Examples of Validation using a Custom Tolerance

- If r_1 has a value of 50 user units and the circle tolerance parameter is .1 user units, then r_2 must be in the range of 49.9 to 50.1 user units.
- If r_1 has a value of 2000 user units and the circle tolerance parameter is 1 user units, then r_2 must be in the range of 1999 to 2001 user units.

TIP

Use LREAL variables and LREAL versions of math functions when calculating the desired circle parameters inside a KAS application.

The LREAL versions of functions usually have an 'l' at the end of their name.

Example: The LREAL version of cos is cosl.

This helps avoid errors.

10.6.0.0.1.1 Perform a Complete Circular Move

Use this procedure to perform a full circle.

1. Call either the MC_MoveCircAbs or MC_MoveCircRel function block.
2. Set **CircMode** to Center (**MC_CIRC_MODE_CENTER**).
3. Set the **EndPoint** to be the same as the start point.
4. Repeat as necessary for multiple rotations.

NOTE

MC_CIRC_MODE_BORDER cannot be used because it is limited to angles <360°.

10.6.0.0.2 Perform a Linear Move

Linear moves can be programmed using absolute or relative positions using these function blocks:

- MC_MoveLinAbs commands interpolated linear movement on an axes group to the specified absolute positions.
- MC_MoveLinRel commands interpolated linear movement on an axes group to the specified relative positions.

Prior to performing any coordinated moves, some setup is needed.

- See Create a Linear or Circular Coordinated Motion Application.
- Once these steps have been performed, a linear move can be performed.

In these examples, two linear moves are performed.

- "Absolute Linear Move" (→ p. 526)
- "Relative Linear Move" (→ p. 526)
- "Linear Move With More Than Two Axes" (→ p. 527)

10.6.0.0.3.1 Absolute Linear Move

In this move, an absolute linear move goes from (0, 0) to (100, 200).

- Call MC_MoveLinAbs.
 - PositionArray is an array of absolute end positions containing one position for each axis in the group.
 - The input velocity, acceleration, deceleration, and jerk establish the maximum values for the move.

```
PosArrayAbs[0] := 100;
PosArrayAbs[1] := 200;
TransParam[0] := 0;

Inst_MC_MoveLinRel(TRUE, Group1_ref, PosArrayAbs, MaxVel, MaxAcc,
MaxDec, 0, CS_ACS, BM_BUFFERED, TM_NONE, TransParam);
```

In the example, a linear move is performed on axis group **Group1_ref**.

- PosArrayAbs contains the absolute end points of the axes in the group.
 - The axis stored in position 0 (IdentInGroup) of the group is moved to 100.0.
 - The axis stored in position 1 of the group is moved to 200.0.
- The maximum velocity is specified by variable **MaxVel** and is specified in User unit/sec.
- The maximum acceleration and deceleration are specified by variables **MaxAcc** and **MaxDec** and are specified in User unit/sec².
- The coordinate system is ACS.
- The BufferMode is set to BM_BUFFERED, indicating the move is buffered.
 - See "Buffer Modes" (→ p. 769) for detailed information.
- The TransitionMode is set to TM_NONE, indicating no transition mode is used.
 - See "Transition Between Moves" (→ p. 535).
- The TransParam array is required.
 - The contents can be set to 0 because the transition mode is not being used.
 - There has to be one array entry for each axis in the group.

10.6.0.0.4.2 Relative Linear Move

In this move, a relative linear move goes a distance of (-75, 50) from the end of the first move.

- Call MC_MoveLinRel.
- The Distance input is an array of distances, one distance for each axis in the group.
- The input velocity, acceleration, deceleration, and jerk establish the maximum values for the move.

```
DistArrayRel[0] := -75.0; // Start pt 100 - rel 75 -> 25 absolute end
pt
DistArrayRel[1] := 50.0; // Start pt 200 + rel 50 -> 250 absolute end
pt
TransParam[0] := 0;

Inst_MC_MoveLinRel(TRUE, Group1_ref, DistArrayRel, MaxVel, MaxAcc,
MaxDec, 0, CS_ACS, BM_BUFFERED, TM_NONE, TransParam);
```

In the example, all the variables have the same meaning as the absolute linear example except DistArrayRel.

- DistArrayRel contains the relative distance to move for each axis in the group.
- The axis stored in position 0 (IdentInGroup) of the group is moved a distance of -75.0.
- The axis stored in position 1 of the group is moved a distance of 50.0.

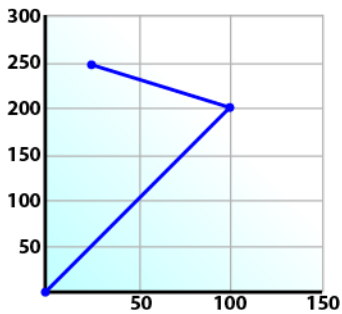

10.6.0.0.5.3 Linear Move With More Than Two Axes

NOTE

The dimensionality of the move is determined by the number of axes mapped to the group. This implies that a group which could hold a maximum of three or more axes does two dimensional moves if it only has two valid axes mapped to it.

To perform higher dimensional moves, additional axes must be added to the group.

The procedure for this are in Create a Linear or Circular Coordinated Motion Application.

After the additional axes are added, perform these steps.

1. From the Dictionary, update the array size of the variable being passed (PosArrayAbs and DistArrayRel in the "Absolute Linear Move" (→ p. 526) and "Relative Linear Move" (→ p. 526) examples) to the Position input so its length matches the maximum number of axes allowed in the group.
2. Set the desired values for the additional axes in the now larger position arrays.

10.6.0.1 Differences between MC_GrpHalt and MC_GrpStop

MC_GrpHalt and MC_GrpStop both perform a controlled motion stop of all axes in an axes group.

These are the differences between the function blocks.

MC_GrpHalt	MC_GrpStop
MC_GrpHalt can be aborted by these other commands: <ul style="list-style-type: none"> • MC_GrpHalt • MC_GrpStop • MC_Move command (e.g., MC_MoveLinAbs, MC_MoveCircRel, etc.) 	MC_GrpStop cannot be aborted by any other command.
While MC_GrpHalt is active, the group state is GroupMoving .	<ul style="list-style-type: none"> • While MC_GrpStop is active, the group state is GroupStopping. • See "Group State Diagrams" (→ p. 514).
When MC_GrpHalt is complete, the group state goes to GroupStandBy .	<ul style="list-style-type: none"> • When MC_GrpStop is complete, the DONE output is TRUE. • The EXECUTE input must be set to FALSE before the group state can go to GroupStandBy.

See Also

- "What MC_GrpHalt Does" (→ p. 528)
- "What MC_GrpStop Does" (→ p. 530)

10.6.0.1.1 What MC_GrpHalt Does

MC_GrpHalt performs a controlled motion stop of all axes in a coordinated motion group.

See "Differences between MC_GrpHalt and MC_GrpStop" (→ p. 527).

Example

This example demonstrates a linear coordinated move with a starting point of (0,0) and an endpoint of (200, 0).

- The first and second MC_GrpHalt commands are called while the linear coordinated move is still moving to the endpoint.
- In the oscilloscope, the second call to MC_GrpHalt aborts the first MC_GrpHalt as seen by the new deceleration rate.
- The path velocity reaches zero (approximately (60, 0)) before the linear coordinated move reaches its endpoint value.

NOTE

For demonstration purposes, it is assumed that the axes and group have been properly setup and configured. Example steps to setup coordinated motion are listed in "Create a Linear or Circular Coordinated Motion Application" (→ p. 518).

```

1: // Perform Linear ABSOLUTE move start (0,0) end (200,0)
PosAbs[0]:= 0;
PosAbs[1]:= 200;
PosAbs[2]:= 0;

pathVelocity := Inst_MC_GrpReadCmdVel2.PathVelocity;

Inst_MC_MoveLinAbs(TRUE, Group1_ref, PosAbs, Velocity, Acceleration,
Deceleration, Jerk, CS_ACS, BM_ABORTING, TM_NONE, TransParam);
Inst_TON3(true, t#600ms); //Allow for the move to reach path velocity
before calling MC_GrpStop
Inst_TON3.Q THEN
    MC_MoveCounter := MC_MoveCounter + 1;
    Inst_TON3(false, t#100ms);
END_IF;

2: //Perform a halt on the group
halt_deceleration := 50.0;

pathVelocity := Inst_MC_GrpReadCmdVel2.PathVelocity;

Inst_MC_GrpHalt(TRUE, Group1_ref, halt_deceleration, default_jerk);

Inst_TON3(true, t#200ms); //Allow for first halt deceleration rate to be
captured on the scope
IF Inst_TON3.Q THEN
    MC_MoveCounter := MC_MoveCounter + 1;
    Inst_TON3(false, t#100ms);
END_IF;

```



```

3: // Perform a second halt increasing the deceleration value.
// The second call to MC_GrpHalt will abort the first MC_GrpHalt
halt_deceleration := 200.0;

pathVelocity := Inst_MC_GrpReadCmdVel2.PathVelocity;

Inst_MC_GrpHalt1(TRUE, Group1_ref, halt_deceleration, default_jerk);

Inst_TON3(true, t#200ms);
IF ((Inst_TON3.Q) and (Inst_MC_GrpHalt1.Done Or Inst_MC_GrpHalt1.Error)) THEN
    Inst_TON3(false, t#100ms);
    Inst_MC_MoveLinAbs(FALSE, Group1_ref, PosAbs, default_velocity, default_
acceleration, default_deceleration, default_jerk,
    CS_ACS, BM_ABORTING, TM_NONE, TransParam);
    Inst_MC_GrpHalt1(FALSE, Group1_ref, default_deceleration, default_jerk);
END_IF;

```

When MC_GrpHalt is called in the example:

- The current move is aborted.
 - A controlled motion stop is applied to axes group **Group1_ref**.
 - The deceleration value, **halt_deceleration** is set to 50.0 User unit/sec² on the first call and 200.0 User unit/sec² on the second call.
 - It is applied to the path velocity until it reaches 0 (zero) when the MC_GrpHalt command is issued during a coordinated motion move.
- The group state is **GroupMoving** while the coordinated move is decelerating.
- The group state goes to **GroupStandBy** once the path velocity reaches 0 (zero).
- Any coordinated moves in the buffer are flushed.
- New coordinated moves can be queued up upon completion of the MC_GrpHalt command.

NOTE

This behavior is different than the MC_GrpStop command.
See "Differences between MC_GrpHalt and MC_GrpStop" (→ p. 527).

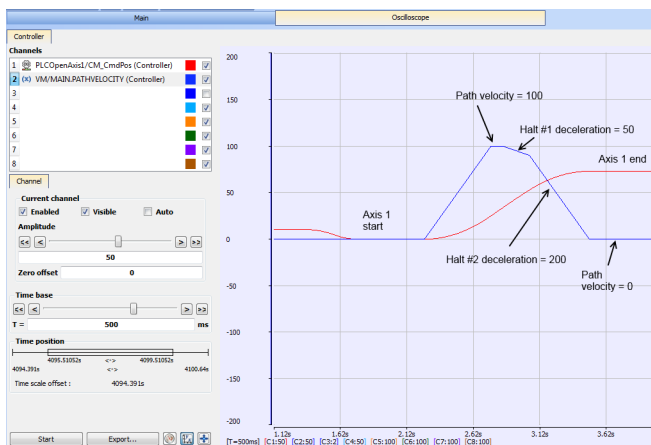

Figure 11-3: Oscilloscope Representation of linear coordinated move with a MC_GrpHalt command called twice.

10.6.1 Exceptions

- The deceleration rate from the MC_GrpHalt function block is only applied to the absolute and relative coordinated motion moves.

- Direct coordinated motion moves use the default deceleration value as defined by the AxisRef.
- MC_GrpHalt cannot occur if a group is not enabled.
- An MC_GrpHalt command may be aborted by another MC_GrpHalt command, a MC_GrpStop command or a MC_Move* command.
- When there are two coordinated motion moves (**Active** and **Next**) in the queue, and the path velocity does not reach 0 (zero) before the end of the **Active** move, the path velocity continues to reach zero during the **Next** move.
- The deceleration rate is increased if there is only one **Active** coordinated move and the path velocity cannot reach zero before the endpoint.
 - This prevents overshooting the endpoint.
- The halt action pauses during S-Curve Corner transitions.
 - Any halt in progress continues after the S-Curve Corner transition is complete.
 - If a halt is started during an S-Curve Corner transition, the halt action starts after the S-Curve Corner transition completes.
 - While a halt action is in progress, there may be a discontinuity in acceleration at the endpoints of S-Curve Corner transition.
- An MC_GrpHalt command does not prevent performing a single axis motion.

10.6.1.0.1 What MC_GrpStop Does

MC_GrpStop performs a controlled motion stop of all axes in a coordinated motion group.

See "Differences between MC_GrpHalt and MC_GrpStop" (→ p. 527).

Example

This example demonstrates a linear coordinated move with a starting point of (0,0) and an endpoint of (200, 0).

- MC_GrpStop is called while the linear coordinated move is still moving to the endpoint.
- In the oscilloscope, the path velocity reaches zero (approximately [100,0]) before the linear coordinated move reaches its endpoint value.

Linear Move Parameters	MC_GroupStop Parameters
Velocity = 100	N/A
Acceleration = 200	N/A
Deceleration = 200	Declaration - 75
Jerk = 0	Jerk = 0

NOTE

For demonstration purposes, it is assumed that the axes and group have been properly setup and configured. Example steps to setup coordinated motion are listed in "Create a Linear or Circular Coordinated Motion Application" (→ p. 518).

```

Inst_MC_GrpReadCmdPos(TRUE, Group1_ref, CS_ACS, CmdPositionArray);
Inst_MC_GrpReadCmdVel2(TRUE, Group1_ref, CS_ACS, VelocityArray);
CASE MC_MoveCounter OF

0: // Enable the group
Inst_MC_GrpEnable(TRUE, Group1_ref);
Inst_TON3( true, t#1500ms ); // Allow for turning on the scope
IF ((Inst_TON3.Q) and (Inst_MC_GrpEnable.Done OR Inst_MC_GrpEnable.Error))
THEN

    Inst_TON3(false, t#1s);

```

```

    IF (Inst_MC_GrpEnable.Error) THEN
        PrintMessage( LEVEL_INFO (*DINT*), 'MC_GrpEnable failed - ErrorID:
' + any_to_string(Inst_MC_GrpEnable.ErrorID));
    END_IF;

    Inst_MC_GrpEnable(FALSE, Group1_ref);
    MC_MoveCounter := MC_MoveCounter + 1;
END_IF;

1: // Perform Linear ABSOLUTE move start (0,0) end (200,0)
PosAbs[0]:= 0;
PosAbs[1]:= 200;
PosAbs[2]:= 0;

pathVelocity := Inst_MC_GrpReadCmdVel2.PathVelocity;

Inst_MC_MoveLinAbs(TRUE, Group1_ref, PosAbs, Velocity, Acceleration,
Deceleration, Jerk,
    CS_ACS, BM_ABORTING, TM_NONE, TransParam);

Inst_TON3(true, t#600ms); //Allow for the move to reach path velocity before
calling MC_GrpStop
IF Inst_TON3.Q THEN
    MC_MoveCounter := MC_MoveCounter + 1;
    Inst_TON3(false, t#100ms);
END_IF;

2: //Perform a stop on the group
stop_deceleration := 75.0;

pathVelocity := Inst_MC_GrpReadCmdVel2.PathVelocity;

Inst_MC_GrpStop(TRUE, Group1_ref, stop_deceleration, default_jerk );

Inst_TON3( true, t#200ms );
IF ((Inst_TON3.Q) AND (Inst_MC_GrpStop.Done Or Inst_MC_GrpStop.Error)) THEN
    IF Inst_MC_GrpStop.Error THEN
        PrintMessage( LEVEL_INFO (*DINT*), 'Step '+any_to_string(MC_
MoveCounter)+'MC_GrpStop ERROR. ErrorID('+any_to_string(Inst_MC_
GrpStop.ErrorID)+'), Description: '+MC_ErrorDescription(any_to_int(Inst_MC_
GrpStop.ErrorID)));
    END_IF;

    Inst_TON3(false, t#100ms);

    Inst_MC_MoveLinAbs(FALSE, Group1_ref, PosAbs, default_velocity, default_
acceleration, default_deceleration, default_jerk,
CS_ACS, BM_ABORTING, TM_NONE, TransParam);

```

```
Inst_MC_GrpStop(FALSE, Group1_ref, stop_deceleration, default_jerk);
END_IF;
```

When MC_GrpStop is called in the example:

- The current move is halted.
- A controlled motion stop is applied to axes group **Group1_ref**.
- The deceleration value, **stop_deceleration**, is set to 75.0 User unit/sec².
 - It is applied to the path velocity until it reaches 0 (zero).
- The group state is **GroupStopping** when the MC_GrpStop function block becomes active.
- While the axes group is in the **GroupStopping** state, no other function blocks can perform any motion on the same axes group.
 - Once the path velocity reaches 0, the **Done** output is TRUE.
- The **Execute** input must be set to FALSE before the group state can go to **GroupStandBy**.
- Any coordinated moves in the buffer are flushed.
- New coordinated moves can be queued up upon completion of the MC_GrpStop command.

NOTE

This behavior is different than the MC_GrpHalt command.
See "Differences between MC_GrpHalt and MC_GrpStop" (→ p. 527).

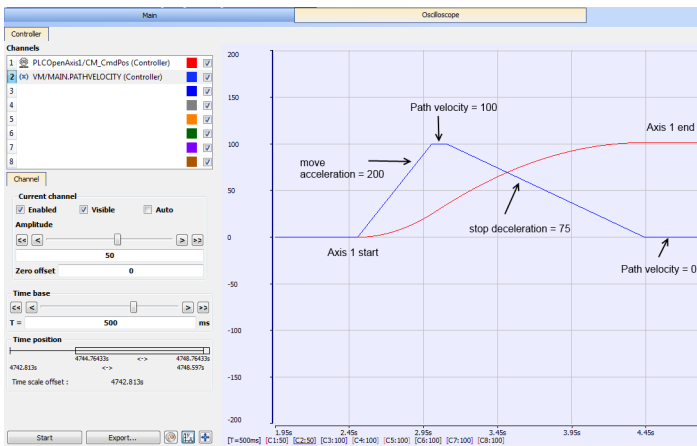

Figure 11-4: Oscilloscope Representation of linear coordinated move with a MC_GrpStop.

10.6.2 Exceptions

- The deceleration rate from the MC_GrpStop function block is only applied to the absolute and relative moves.
 - Direct moves use the default deceleration value as defined by the AxisRef.
- MC_GrpStop cannot occur if a group is not enabled.
- An MC_GrpStop command **cannot** be aborted by any other commands.
- When there are two coordinated motion moves (**Active** and **Next**) in the queue, and the path velocity does not reach 0 (zero) before the end of the **Active** move, the path velocity continues to reach zero during the **Next** move.
- The deceleration rate is increased if there is only one **Active** coordinated move and the path velocity cannot reach zero before the endpoint.
 - This prevents overshooting the endpoint.
- The stop action pauses during S-Curve Corner transitions.
 - Any stop in progress continues after the S-Curve Corner transition is complete.
 - If a stop is started during an S-Curve Corner transition, the stop action starts after the S-Curve Corner transition completes.
 - While a stop action is in progress, there may be a discontinuity in acceleration at the endpoints of the S-Curve Corner transition.

- An MC_GrpStop command does not prevent performing a single axis motion.

10.6.2.1 Handling Axis Errors

Coordinated motion error handling is configurable on a per axis group basis.

- When a PLCopenaxis error occurs, the "Default Error Handling Behavior" (→ p. 533) is for all axes in the group stop.
- This means motion interpolation stops, active and next queues are cleared, and the group state **GroupErrorStop** is enabled.
- The position loop on the drives in the group are opened and the drives are disabled.

The "Optional Error Handling Behavior" (→ p. 533) when a PLCopen axis error occurs is for only the PLCopen axis that caused the error to have its position loop opened and that drive is disabled.

- The application is expected to control the motion for the remaining axes in the group.
- The optional feature may be used when stopping all axes is worse than having one axis stop.

10.6.2.1.1 Optional Behavior

- To configure the optional behavior, use the function block MC_GrpWriteBoolPar and set the parameter **IGNORE_AXIS_ESTOP (1000)** to TRUE.
- To check if the optional behavior has been set, call MC_GrpReadBoolPar and read the state of parameter **IGNORE_AXIS_ESTOP (1000)**.
 - If the result is TRUE, the optional behavior is enabled.

The types of PLCopen Axis Errors that affect coordinated motion include:

- Drive errors.
- Drive communication errors.
- User causes E-stop using MC_EStop on an axis in a group.

10.6.2.1.2 Default and Optional Error Handling Behavior

10.6.2.1.3.1 Default Error Handling Behavior

In the default motion error handling case, a user can detect errors using any of these group function blocks:

- MC_GrpReadStatus - Output GroupErrorStop is true if a group error has occurred.
- MC_GrpReadError - Error output is TRUE.
 - ErrorID output is set to 12 if the error is due to E-stop.
- The originating Coordinated Motion command (MC_MoveLinAbs, MC_MoveCircAbs, etc.) will return Error ID 12

To determine which PLCopen axis has generated the error, call MC_ReadAxisErr for each axis in a group.

- The output ErrorID is set to 12.
- MC_ReadStatus for each axis in the group can be called where the output ErrorStop is TRUE if in a E-stop condition.
- Once an error has been detected, the error must first be resolved.
- MC_GrpReset can be called to reset all PLCopen axis errors.
 - This also resets the group status from GroupErrorStop to GroupStandby.
 - The Done output of MC_GrpReset is TRUE if all axis errors have been reset.
 - This function block may take up to 3 seconds to reset some error conditions.

10.6.2.1.4.2 Optional Error Handling Behavior

TIP

This is configurable on a per group basis.

In the optional motion error handling case, the group status GroupErrorStop is not set when an axis is in error.

The application is responsible for monitoring and handling error conditions. The remaining axes in the group will continue moving.

Errors can be detected using this group function block:

- MC_GrpReadBoolPar - Read the result of parameter ID AXIS_ESTOP_ACTIVE (1001).
 - If the result is TRUE, an axis error exists.
- The group function blocks used for the default case of detecting errors (MC_GrpReadStatus and MC_GrpReadError) do not return an error.

To determine which PLCopen axis has generated the error, call MC_ReadAxisErr for each axis in a group.

- The output ErrorID is set to 12.
- MC_ReadStatus for each axis in the group can be called where the output ErrorStop is TRUE if in a E-stop condition.
- Once an error has been detected, the error must first be resolved.
- MC_ResetError can then be called on each axis in error.
 - This function only sends a request to the drive to clear any error.
 - The error is not yet reset when this function returns.
 - MC_ReadStatus still has to be called to verify that the drive error has been resolved.

10.6.2.1.5 Recovery of the System State After an Axis Error

Recovery from axis errors is more complex with the addition of Coordinated Axes Groups (PLCopen Part 4) to KAS Runtime. This is because of additions in the operation of PLCopen Motion and Coordinated motion. This includes:

- Addition of the Coordinated motion Boolean variable that allows the Runtime to IGNORE_AXIS_ESTOP (ID number 1000).
- Addition of the Coordinated motion Boolean variable that allows the Application to read the state of the Runtime Axis errors: AXIS_ESTOP_ACTIVE (ID number 1001).
- Addition of MC_GrpReadBoolPar.
- Addition of MC_GrpWriteBoolPar.

When the application needs to take control of the default behavior where all axes in a group stop when any of them detect an Estop condition, and the Estop condition does not in itself stop all axes (Loss of EtherCAT communication), the application can set the Group Boolean parameter IGNORE_AXIS_ESTOP (ID := 1000) using MC_GrpWriteBoolPar().

- When set to TRUE, the runtime tries to keep axes in the same group as a faulting axis still able to be commanded.
- The intent is to not give up control of the commanded motion, but allow the application to substitute error handling motion that allows a group of axes to stop in a controlled manner.
- Example: Command the remaining axes to a Home position or a relative move away from the position of the faulted axis.

Once the IGNORE_AXIS_ESTOP parameter is set TRUE, the Group of axes does not enter the ERRORSTOP state when an axis encounters an ESTOP condition but remain in STANDBY or MOVING state.

- Instead, the AXIS_ESTOP_ACTIVE (ID := 1001) parameter can be monitored to trigger a response that aborts the current operation and takes control of the axes that can still be controlled.
- To determine which axis has faulted, the MC_ReadStatus() FB is used to monitor each axis and select the appropriate single axis or Coordinated motion commands to execute to take control of the motion and recover from the error.

To restart Coordinated Motion when the error recovery is completed and the faulting axis restored to normal operation, an MC_GrpSetPos() command must be issued to tell the Coordinated Motion Engine where the axes in the faulted Axes Group, following restoration of the single axis fault(s).

This command must be issued in order to reset the faulted axis.

Alternatively, if the MC_GrpWriteBoolPar() function is issued to set the IGNORE_AXIS_ESTOP parameter to FALSE, the Group enters the ERRORSTOP state if an Axis error has not been reset, and the default behavior

and default usage of MC_GrpResetError() function can be used to clear faults instead of the MC_GrpSetPos() function.

10.6.2.2 Transition Between Moves

A transition mode must be specified when a new move is appended to a move that is already in progress.

- Different transition parameters may be required, depending on the transition mode.
- This characterizes the contour of the transition segment.

The supported transition modes are:

- "No Transition (TM_NONE)" (→ p. 535)
- "Corner Distance (TM_CORNER_DISTANCE)" (→ p. 535)
- "S-Curve Corner (TM_SCURVE_CORNER)" (→ p. 536)

10.6.2.2.1.1 Transition Mode Parameters

Parameters	Number of Transition Parameter Array Elements	Transition Parameter Index	Transition Parameter Name	Transition Parameter Description	Units
TM_NONE	0	N/A	N/A	No transition.	N/A
TM_CORNER_DISTANCE	2	0	Corner Distance	Distance to the corner of the deviation and the return point from the original contour.	User units
TM_CORNER_DISTANCE	2	1	Velocity	The velocity value of the transition segment.	User unit/sec
TM_SCURVE_CORNER	1	0	Corner Distance	Distance to the corner of the deviation and the return point from the original contour.	User units

10.6.2.2.2 No Transition (TM_NONE)

Insert no transition contour segment.

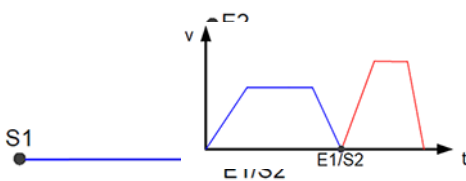

Motion Path Motion Velocity Profile

- The motion blocks are not modified and no transition curve is inserted using this mode.
 - This is the only possible transition mode for the "Buffer Modes" (→ p. 769).
- No transition parameters are used for this transition mode.

10.6.2.2.3 Corner Distance (TM_CORNER_DISTANCE)

Transition with given corner distance.

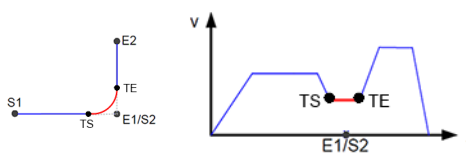

Motion Path Motion Velocity Profile

The corner distance transition mode is specified using **TM_CORNER_DISTANCE** as the transition mode for a motion block.

10.6.2.2.4.1 Transition Parameter Index

Transition Parameter Index	Name	Description
0	Corner Distance	Distance to the corner of the deviation and the return point from the original contour.
1	Velocity	The velocity value of the transition segment.

- Corner Distance transitions are handled differently, depending upon whether the connecting moves are lines or arcs, and all of the possible combinations, (line-line, arc-arc, line-arc, arc-line).
 - Arc-to-Arc transitions shorten the arc with the larger radius by the corner distance.
 - See "Arc-to-Arc Transitions" (→ p. 537).
 - Line-to-Arc and Arc-to-Line transitions shorten the linear move.
 - See "Line-to-Arc and Arc-to-Line Transitions" (→ p. 540).
 - Line-to-Line transitions shorten the next move by the corner distance.
 - See "Line-to-Line Transitions" (→ p. 542).

10.6.2.2.5 S-Curve Corner (TM_SCURVE_CORNER)

Transition with given corner distance, using Jerk for each axis profile.

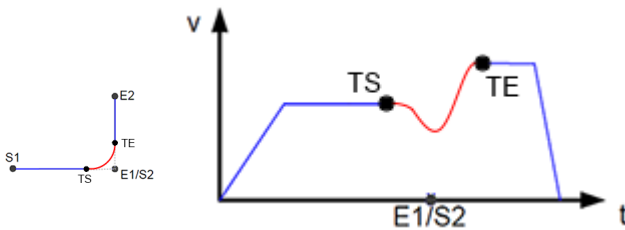

Motion Path Motion Velocity Profile

The S-Curve Corner transition mode is specified using **TM_SCURVE_CORNER** as the transition mode for a motion block.

10.6.2.2.6.1 Transition Parameter Index

Transition Parameter Index	Name	Description
0	Corner Distance	Distance to the corner of the deviation and the return point from the original contour.

- All S-Curve Corner transitions start and end the transition with zero acceleration.
 - If an S-Curve Corner transition is used with buffer mode **BM_ABORTING** and during acceleration or deceleration phases of the first move, then the axes experience an acceleration discontinuity at beginning of the transition.
- Only Line-to-Line transitions are supported with S-Curve Corner.
 - Line-arc, arc-arc, arc-line are **not** supported.
- Line-to-Line transitions shorten the next move by the corner distance.
 - See S-Curve Corner Line-to-Line Transitions.
- Changes to the velocity override during the transition do not take effect until after the transition has completed.
- S-Curve Corner transitions only depend on the corner distance, the incoming and outgoing move velocities, and the incoming and outgoing move directions.

- The transition may exceed the maximum specified values for velocity, acceleration, deceleration, and jerk of the incoming and outgoing moves.
 - Jerk and peak acceleration increase with a larger angle between the incoming and outgoing move directions.
 - Jerk and peak acceleration decrease with a larger corner distance.
- To approximate the path peak acceleration and jerk during the transition, we can use these equations:
 - V_{avg} = The average of the slew speeds of the incoming and outgoing moves.
 - θ = The angle between incoming and outgoing moves.
 - CD = Corner distance.
 - $typical\ accel = \frac{8}{7} \cdot \frac{v_{avg}^2}{CD} \cdot \sqrt{\sin\left(\frac{\theta}{2}\right)}$
 - $typical\ jerk = 16 \cdot \frac{v_{avg}^3}{CD^2} \cdot \sin^2\left(\frac{\theta}{2}\right)$
 - If actual accel = k_a typical accel and actual jerk = k_j typical jerk, then:
 - k_a has an average value of 1 with a standard deviation of 0.5. Values of k_a have been observed as large as 3.
 - k_j has an average value of 1 with a standard deviation of 1.1. Values of k_j have been observed as large as 12.

NOTE

The formulas are approximate guidelines.
Your application may experience different behavior.

See Also

- MC_MoveCircAbs
- MC_MoveCircRel
- MC_MoveLinAbs
- MC_MoveLinRel

10.6.2.2.7 Arc-to-Arc Transitions

In arc-to-arc transition mode, the transitions are processed as.

1. The arc with the larger radius is shortened by an arc length equal to the corner distance.
2. Using this point, a transition move is calculated such that it is tangent to both arcs.
3. The arc with the smaller radius is shortened to the point where it is tangent with the transition move.

The transition move that connects the two original arcs derives its velocity from the velocity transition parameter and the acceleration and deceleration values are derived from the next move.

These are the special cases for Arc-to-Arc transitions:

- "Intersection Transition" (→ p. 537)
- "Line Segment Transition" (→ p. 538)
- "Same Circle: Opposite Direction Transition" (→ p. 538)
 - "n-Degree: Arcs in Opposite Direction" (→ p. 538)
- "Same Circle: Same Direction Transition" (→ p. 539)
 - "n-Degree: Arcs in Same Direction" (→ p. 539)
- "Tangent Transition: Opposite Direction" (→ p. 539)
- "Zero-distance Transition" (→ p. 540)

10.6.2.2.8.1 Intersection Transition

[Click to view Intersection Transition](#)

This occurs when the arcs intersect at two locations and the corner distance is equal to the arc length between the two intersections on the larger arc.

- The transition move is zero distance.
- If the buffer mode is **Buffered**, the path velocity goes to zero.
- All other buffer modes may cause a large acceleration and jerk.

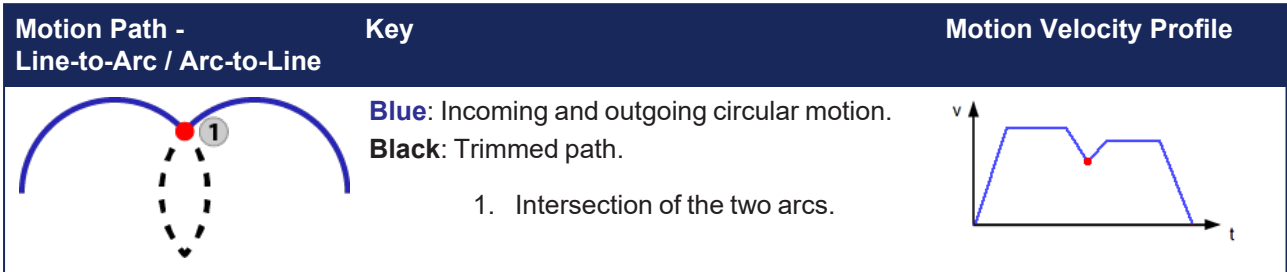

10.6.2.2.9.2 Line Segment Transition

[Click to view Line Segment Transition](#)

- For certain values of corner distance, the transition arc has an infinite radius.
 - A line segment is used instead.

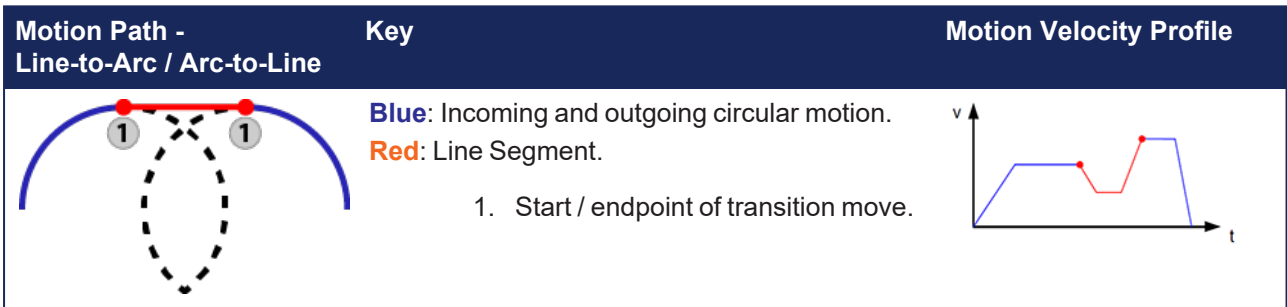

10.6.2.2.10.3 Same Circle: Opposite Direction Transition

[Click to view Same Circle: Opposite Direction Transition](#)

The arcs are shorted by an arc length equal to the corner distance.

- A zero distance transition is inserted if both arcs lie on the same circle and are in the opposite direction.
- If the buffer mode is **Buffered**, the path velocity goes to zero.
- All other buffer modes may cause a large acceleration and jerk.

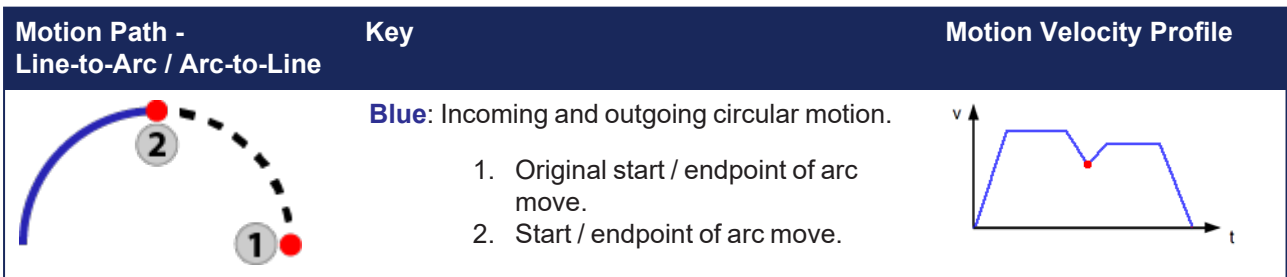

10.6.3 n-Degree: Arcs in Opposite Direction

Motion Path - Line-to-Arc / Arc-to-Line	Key	Motion Velocity Profile
	<p>Blue: Incoming and outgoing circular motion. Black: Trimmed path. Red: Transition arc.</p> <p>1. Start / endpoint of arc move.</p>	

10.6.3.0.1.1 Same Circle: Same Direction Transition

[Click to view Same Circle: Same Direction Transition](#)

A transition arc with a length of twice the corner distance is added if both arcs lie on the same circle and are in the same direction.

- This does not affect the path but does affect blending.

Motion Path - Line-to-Arc / Arc-to-Line	Key	Motion Velocity Profile
	<p>Blue: Incoming and outgoing circular motion. Red: Transition arc.</p> <p>1. Start / endpoint of arc move. 2. Original start / endpoint.</p>	

10.6.4 n-Degree: Arcs in Same Direction

Motion Path - Line-to-Arc / Arc-to-Line	Key	Motion Velocity Profile
	<p>Blue: Incoming and outgoing circular motion. Black: Trimmed path. Red: Transition arc.</p> <p>1. Start / endpoint of arc move. 2. Corner distance.</p>	

10.6.4.0.1.1 Tangent Transition: Opposite Direction

[Click to view Tangent Transition: Opposite Direction](#)

A portion of the arc with the larger radius is replaced by an arc whose length is equal to the corner distance.

- If the arcs have the same radius, the incoming arc is treated as having a larger radius.
- This does not affect the path but does affect blending.

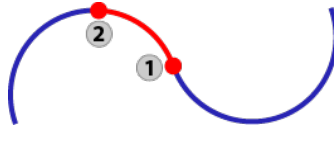
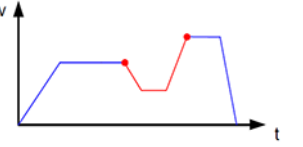
Motion Path - Line-to-Arc / Arc-to-Line	Key	Motion Velocity Profile
	<p>Blue: Incoming and outgoing circular motion. Red: Transition arc.</p> <ol style="list-style-type: none"> 1. Original start / end point of moves. 2. Start / endpoint of arc move. 	

10.6.4.0.2.2 Zero-distance Transition

[Click to view Zero-distance Transition](#)

A zero-distance transition move is inserted when the corner distance is zero.

- This only affects blending.
- If the buffer mode is **Buffered**, the path velocity goes to zero.
- All other buffer modes may cause a large acceleration and jerk.

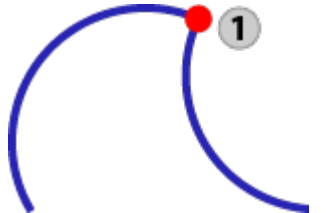
Motion Path - Line-to-Arc / Arc-to-Line	Key	Motion Velocity Profile
	<p>Blue: Incoming and outgoing circular motion.</p> <ol style="list-style-type: none"> 1. Original start / endpoint of arc move. 	<p>User unit/sec</p>

10.6.4.0.3 Line-to-Arc and Arc-to-Line Transitions

With this transition mode, the linear move is shortened when one move is linear and the other is circular.

- The amount is specified by the corner distance.
- A circular arc connects the two moves, allowing for a smooth transition.
- The circular arc that connects the two moves derives its velocity from the transition parameter and the acceleration and deceleration values are derived from the next move.

10.6.5 n-Degree Transition

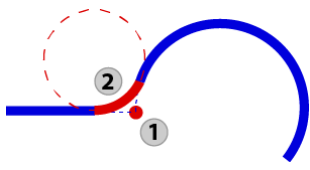
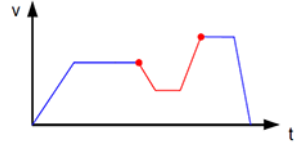
Motion Path - Line-to-Arc / Arc-to-Line	Key	Motion Velocity Profile
	<p>Blue: Incoming and outgoing linear and circular motion. Red: Transition arc.</p> <ol style="list-style-type: none"> 1. Original start / endpoint of linear move. 2. Corner distance. 	

10.6.5.0.1.1 Special Case Transitions

These are the special cases for Line-to-Arc and Arc-to-Line transitions:

- "Intersection Transition" (→ p. 541)
- "Tangent Transition" (→ p. 541)
- "Zero-distance Transition" (→ p. 541)

10.6.6 Intersection Transition

[Click to view Intersection Transition](#)

This is only when the arc intersects the line corner distance away from the point where the line and the arc meet.

- The line intersects the arc a corner distance away from the beginning of the new move.
- The transition move is zero distance.
- If the buffer mode is **Buffered**, the path velocity goes to zero.
- All other buffer modes may cause a large acceleration and jerk.

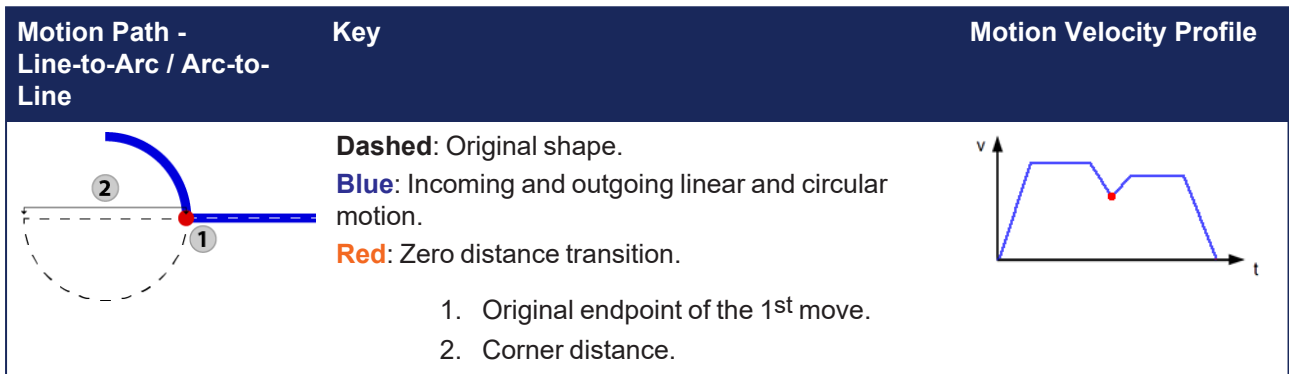

10.6.7 Tangent Transition

[Click to view Tangent Transition](#)

- The linear move is shortened by the corner distance.
- A linear transition move is inserted to cover the distance that was removed.
- The line is tangent to the arc.

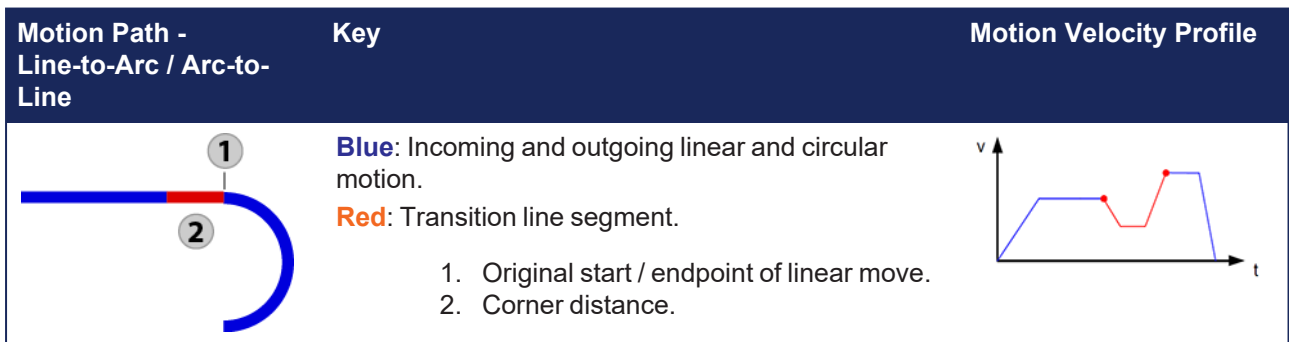

10.6.8 Zero-distance Transition

[Click to view Zero-distance Transition](#)

- A zero distance transition move is inserted.
 - This only affects blending.
- Special behavior for 0-distance transitions.
- If the buffer mode is **Buffered**, the path velocity goes to zero.
- All other buffer modes may cause a large acceleration and jerk.

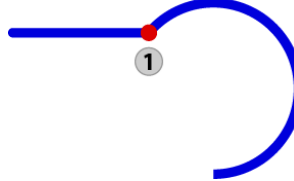
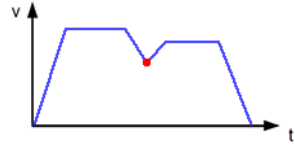
Motion Path - Line-to-Arc / Arc-to-Line	Key	Motion Velocity Profile
	<p>Blue: Incoming and outgoing linear and circular motion.</p> <p>Red: Zero distance transition.</p> <ol style="list-style-type: none"> 1. Original endpoint of the 1st move. 	

10.6.8.0.1 Line-to-Line Transitions

When both moves are linear, the current and next moves are shortened using this transition mode.

- The amount is specified by the corner distance.
- A circular arc connects the two moves, with exceptions.
 - This allows for a smooth transition.
 - See "n-Degree: Transition" (→ p. 542).
- The circular arc that connects the two moves derives its velocity from the transition parameter.
- The acceleration and deceleration values are derived from the next move.

10.6.8.0.2.1 n-Degree: Transition

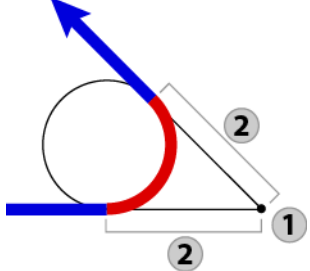
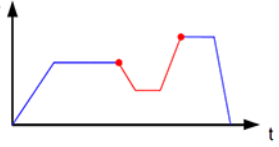
Motion Path - Line-to-Line	Key	Motion Velocity Profile
	<p>Blue: Incoming and outgoing linear motion.</p> <p>Red: Transition arc.</p> <ol style="list-style-type: none"> 1. Original endpoint of the 1st move. 2. Corner distance. 	

10.6.8.0.3.2 Special Case Transitions

These are the special cases for line-to-line transitions:

- "180-degree Transition" (→ p. 542)
- "Zero-degree Transition" (→ p. 543)
- "Zero-distance Transition" (→ p. 543)

10.6.9 180-degree Transition

[Click to view 180-degree Transition](#)

- The current move is shortened by the corner distance when the next move travels in the opposite direction.
- If the buffer mode is **Buffered**, the path velocity goes to zero.
 - All other buffer modes may cause a large acceleration and jerk.
- The new move is in the opposite direction as the old move.
- The sudden change in the direction of motion may result in large jerks to the axes.

	<p>Blue: Incoming linear motion. Red: Outgoing linear motion.</p> <ol style="list-style-type: none"> 1. Original endpoint of the 1st move. 2. Corner distance. 	
--	--	--

10.6.10 Zero-degree Transition

[Click to view Zero-degree Transition](#)

- The path remains unchanged.
- A linear transition move with the specified transition velocity is inserted.
- The new move continues in same direction as old move - continuous behavior.

Motion Path - Line-to-Line	Key	Motion Velocity Profile
	<p>Blue: Incoming and outgoing linear motion. Red: Transition line segment.</p> <ol style="list-style-type: none"> 1. Original endpoint of the 1st move. 2. Corner distance. 	

10.6.11 Zero-distance Transition

[Click to view Zero-distance Transition](#)

- A zero distance transition move is inserted.
 - This only affects blending.
- If the buffer mode is **Buffered**, the path velocity goes to zero.
 - All other buffer modes may cause a large acceleration and jerk.
- Motion passes the first move's endpoint.
- There is no transition arc.
- A sudden change in the direction of motion may result in large jerks to the axes.

Motion Path - Line-to-Line	Key	Motion Velocity Profile
	<p>Blue: Incoming and outgoing linear motion. Red: Zero distance transition move.</p> <ol style="list-style-type: none"> 1. Original endpoint of the 1st move. 	

10.6.11.0.1 S-Curve Corner Line-to-Line Transitions

This topic describes the behavior when both moves are linear the current and next moves are shortened using the S-Curve Corner transition mode.

- The amount each linear move is shortened is specified by the corner distance.
- A spline with continuous acceleration is used to connect the two linear moves.
 - This allows for a smooth transition.
 - See "n-Degree: Transition" (→ p. 543).

10.6.11.0.2.1 n-Degree: Transition

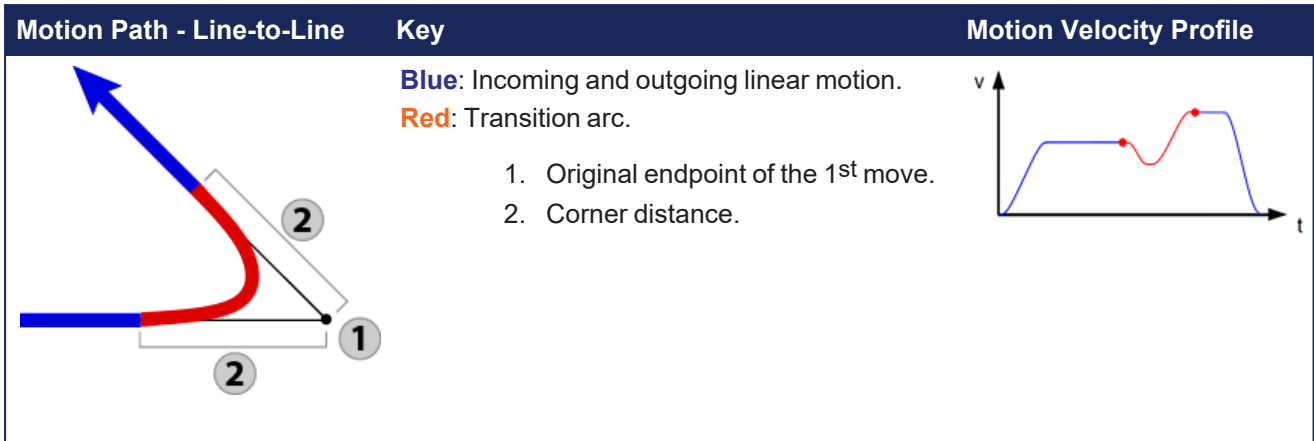

10.6.11.0.3.2 Special Case Transitions

These are the special cases for line-to-line transitions:

- "180-degree Transition" (→ p. 544)
- "Zero-degree Transition" (→ p. 544)
- "Zero-distance Transition" (→ p. 545)

10.6.12 180-degree Transition

[Click to view 180-degree Transition](#)

- The current move is shortened by the corner distance when the next move travels in the opposite direction.
- The velocity drops to zero between the two moves.
- The new move is in the opposite direction as the old move.
- The velocity drops to zero to avoid large accelerations and jerks to the axes.

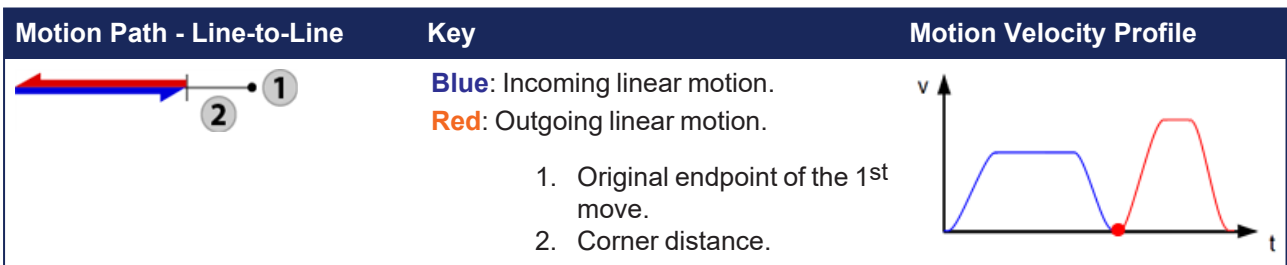

10.6.13 Zero-degree Transition

[Click to view Zero-degree Transition](#)

- The path remains unchanged.
- The corner distance does not affect the path or velocity profile.
- A transition element is not inserted.
- The velocity blending acts like BM_BLENDING_PREVIOUS is being used.
 - See "Blending Between Moves" (→ p. 516).
- The new move continues in same direction as old move - continuous behavior.
- No transition segment is inserted.

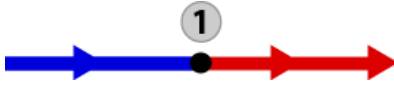
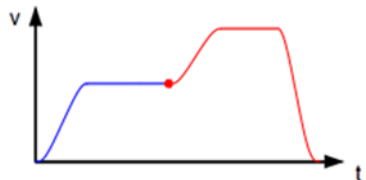
Motion Path - Line-to-Line	Key	Motion Velocity Profile
	<p>Blue: Incoming linear motion.</p> <p>Red: Outgoing linear motion.</p> <p>1. Original endpoint of the 1st move.</p>	

10.6.14 Zero-distance Transition

[Click to view Zero-distance Transition](#)

- The path remains unchanged and a transition element is not inserted.
- The velocity blending acts like BM_BLENDED_PREVIOUS is being used.
 - See "Blending Between Moves" (→ p. 516).
- Motion passes the first move's endpoint.
- No transition segment is inserted.
- A sudden change in the direction of motion may result in large jerks to the axes.

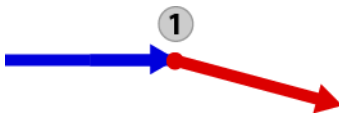
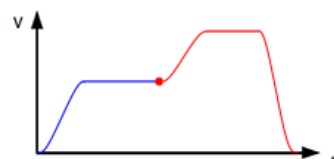
Motion Path - Line-to-Line	Key	Motion Velocity Profile
	<p>Blue: Incoming and outgoing linear motion.</p> <p>Red: Zero distance transition move.</p> <p>1. Original endpoint of the 1st move.</p>	

10.7 Motion Techniques

This chapter explains advanced concepts and procedures related to **motion techniques** that are possible with the KAS-IDE.

10.7.1 Create a Digitizing Axis

Digitizing axes are supported by PLCopen-based projects.

NOTE

This procedure is the general process.
The specifics will vary depending upon the EtherCAT network.

1. From the Project View, right-click the **Controller > Motion > PLCopen** item and select **New Axis**.

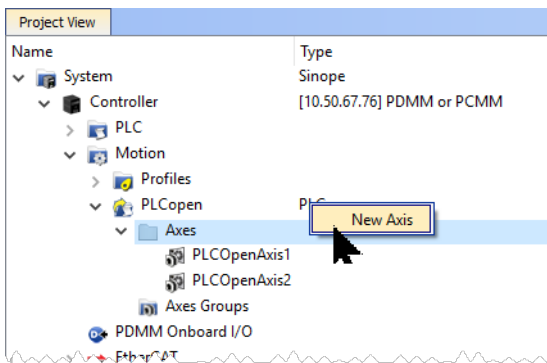

2. Give the axis a name.
Spaces are not supported.
See "Common Axis Parameters" (→ p. 169).
3. Define the data in the **EtherCAT Bus** and **Feedback Settings** areas.
See "Digitizing Axis Parameters" (→ p. 170).
4. Define the "Axis Data Parameters" (→ p. 172).

What happens when the device providing feedback to the digitizing axis is removed?

The feedback position becomes zero if the device providing the Feedback Position for the Digitizing axis is removed using the ECATDeviceAction function block.

The feedback position data coming from the device is automatically connected to the digitizing axis when the device is reconnected to the EtherCAT network.

See Also

- "Create a Digitizing Axis From Code" (→ p. 546)
- "Create a Digitizing Axis When Using an Imported ENI File" (→ p. 546)
- "Create a Digitizing Axis When EtherCAT Devices Are Not Connected" (→ p. 548)
- "Create a Digitizing Axis When EtherCAT Devices Are Defined" (→ p. 547)
- "Digitizing Axis - PLCopen Setup" (→ p. 549) about digitizing axes.

10.7.1.1 Create a Digitizing Axis From Code

This procedure creates digitizing axes without using the GUI.

1. The MC_CreatePLCAxis function block is used to create the axis.
2. The MC_InitAxisFeedback function is used to initialize the feedback.

```
(* ----- Create PLCopen axis 'Digit1' *)
MC_CreatePLCAxis( 'Digit1', 'EtherCATDriver', 1001, 3, 1, 1, 1, 1, LREAL#0, 4
);
MC_InitAxisFeedback( 3, 24804, 2, 32 );
```

10.7.1.2 Create a Digitizing Axis When Using an Imported ENI File

This procedure assumes you are setting up a project when using an imported ENI file.

See "ENI File tab" (→ p. 329) about using ENI files.

1. From the Project View, right-click the **Controller > Motion > PLCopen** item and select **New Axis**.

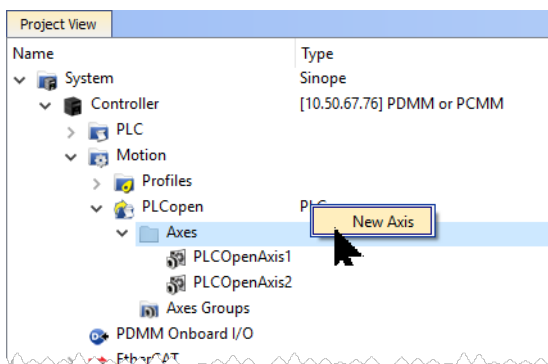

2. Give the axis a name.
Spaces are not supported.
See "Common Axis Parameters" (→ p. 169).
3. Click the **Type** drop-down and select **Digitizing**.
4. Define the data in the **EtherCAT Bus** and **Feedback Settings** areas.
The ENI file provides some information about the digitizing axis.

The **Address**, **CoE Object Index**, **Subindex**, and the **Encoder Resolution** of the device to use are required.

See "Digitizing Axis Parameters" (→ p. 170).

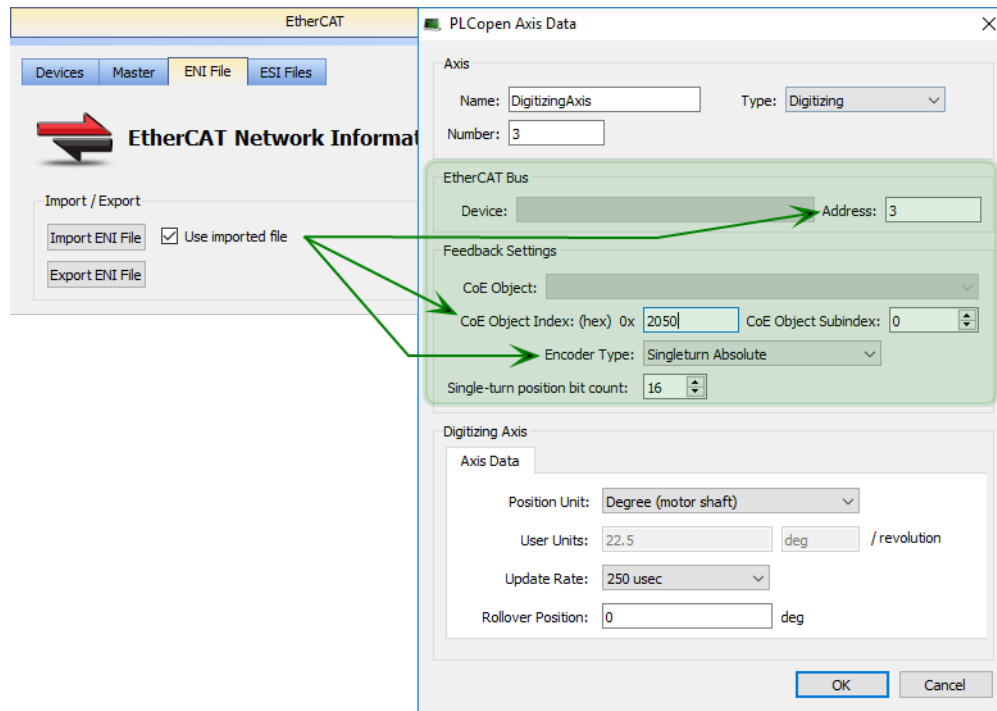

5. Define the "Axis Data Parameters" (→ p. 172).

10.7.1.3 Create a Digitizing Axis When EtherCAT Devices Are Defined

This process assumes that you have already scanned the EtherCAT network and assigned devices to axes.



1. From the Project Tree, right-click on the *Controller > Motion > PLCopen* item and select **New Axis**.

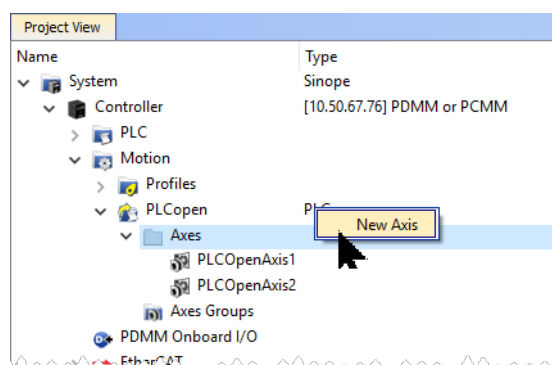

2. Give the axis a name and click **OK**. Note that spaces are not supported and select **"Digitizing"** as the **Type**. See "Common Axis Parameters" (→ p. 169) for details.
3. Digitizing axes have *Bus* and *Feedback Settings* data which needs to be defined. Double-click on the newly defined axis. Using an AKD or AKD2G will automatically set certain parameters, and hide that data. For example the Encoder Resolution for AKD drives is automatically set to 20-bit. See "Digitizing Axis Parameters" (→ p. 170).

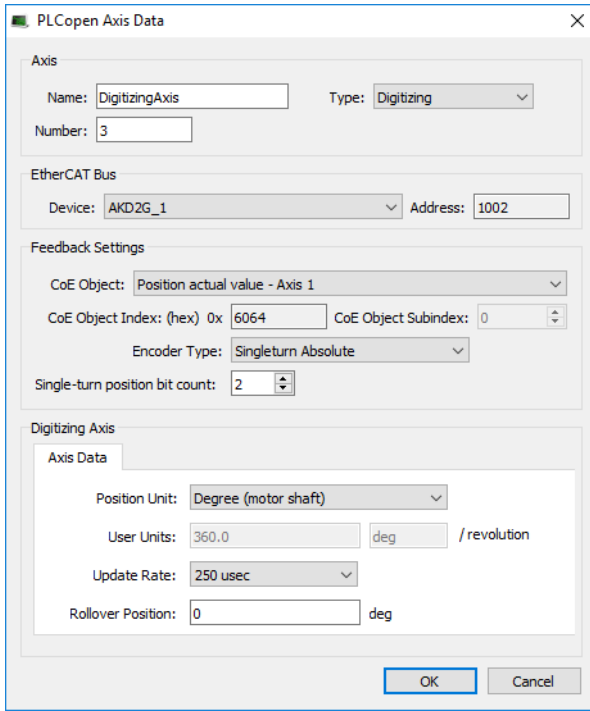

4. Define the "Axis Data Parameters" (→ p. 172).

10.7.1.4 Create a Digitizing Axis When EtherCAT Devices Are Not Connected

This process assumes you are setting up a project and are not connected to the EtherCAT network.

In this example, several devices have been added to the EtherCAT branch of the Project View, including an AKD2G, an AKD-C, and two AKD-Ns.

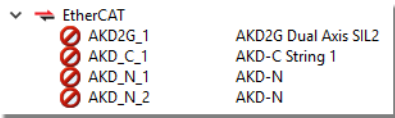

1. From the Project Tree, right-click on the *Controller > Motion > PLCopen* item and select **New Axis**.

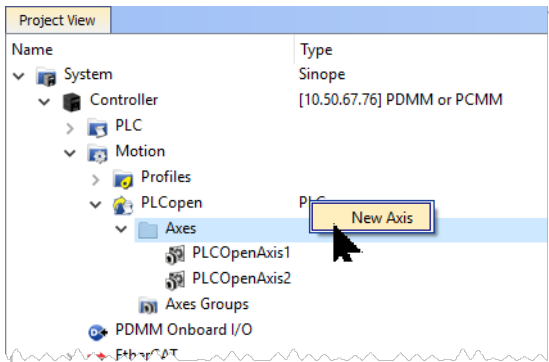

2. Give the axis a name and click **OK**. Note that spaces are not supported and select **"Digitizing"** as the **Type**. See "Common Axis Parameters" (→ p. 169) for details.
3. Digitizing axes have *Bus* and *Feedback Settings* data which needs to be defined. Double-click on the newly defined axis and select the **Device** which will provide the feedback information and the feedback parameters, including the CoE information that will be used. See "Digitizing Axis Parameters" (→ p. 170) for details.

4. Define the "Axis Data Parameters" (→ p. 172).

10.7.1.5 Digitizing Axis - PLCopen Setup

This topic provides the basics of setting up a digitizing axis and describes how to accomplish some common tasks.

See "Common Axis Parameters" (→ p. 169).

- A Digitizing Axis requires a feedback position.
 - The feedback position can come from a secondary feedback of a drive or an EtherCAT device.
 - Typically the AKD, S300, or S700 drives provide the feedback position via the CoE object **0x2050**.

Index	Subindex	Object Name	Size [bit]	PLC Variable
0x2050	0	Position actual val...	32	(Global)/ActPosA1_Feedback2
0x20...	0	Latch status word	16	
0x20...	0	Latch position	32	
0x3470	4	AIN.VALUE	16	Managed in I/O tab
0x6041	0	Status word	16	
0x6063	0	Position actual val...	32	
0x606C	0	Velocity actual val...	32	
0x6077	0	Torque actual value	16	
0x60F4	0	Following error	32	
0x60...	0	Digital inputs	32	Managed in I/O tab

- The Digitizing Axis is created by setting the **Type** to **Digitizing**, selecting the EtherCAT device to provide the feedback, and setting the correct CoE object.

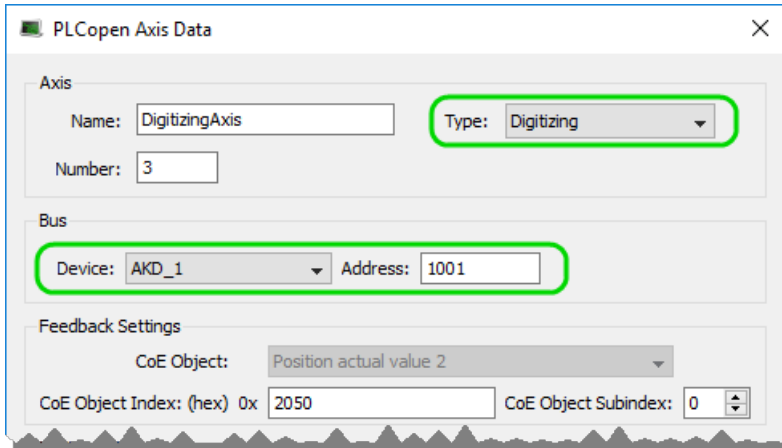

NOTE

First generation AKD drives use certain pre-set values.

- The actual position in user units is read with the MC_ReadActPos function block.

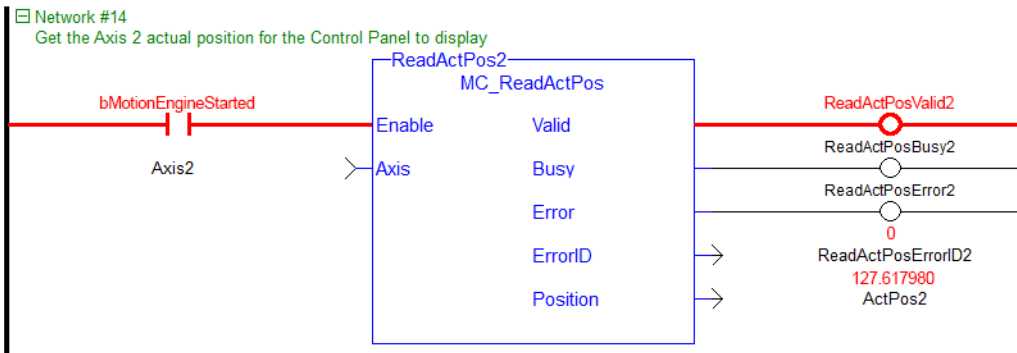

- The position is offset using the MC_SetPos function block.

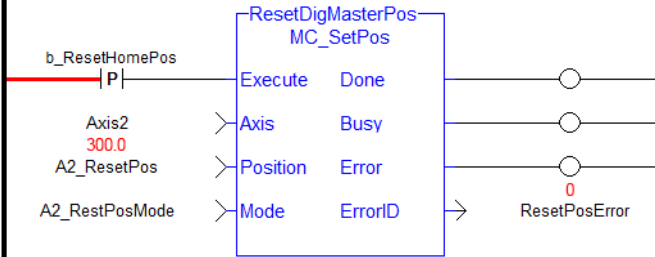

- For AKD drives, the polarity of the feedback signal is changed using drive parameter FB2.DIR.

Parameters

This page lists the current values of all parameters on the device.

Full Name	Value	Units	Parameter	Read/Write
Feedback 1				
Feedback 2				
FB2 counting direction (impact...)	0		FB2.DIR	read-write
Position Feedback Resolution	1,000		FB2.ENCREG	read-write
Feedback 2 Mode	0 - Input - A/B Sig...		FB2.MODE	read-write
FB2.MOTORPHASE	0 deg		FB2.MOTORPHA...	read-write
FB2.MOTORPOLES	6		FB2.MOTORPOL...	read-write
Feedback 2 scaled position	0.000 Counts		FB2.P	read-only
Feedback 2 counting direction	0		FB2.PDIR	read-write

NOTE

If an Endat 2.2 device is used, set FB3.DIR and change DRV.HANDWHEELSRC to 3 to tie the PDO index 2050 parameter read from FB2 to FB3.

What happens when the device providing feedback to the digitizing axis is removed?

The feedback position becomes zero if the device providing the Feedback Position for the Digitizing axis is removed using the ECATDeviceAction function block.

The feedback position data coming from the device is automatically connected to the digitizing axis when the device is reconnected to the EtherCAT network.

10.7.1.6 Digitizing Axis - Encoders without a Z-Channel

If the encoder does not have a Z-channel, there may be some unrelated drive faults associated with the secondary feedback signal.

To disable this, change the setting for FAULT130.ACTION (or fault 131, 132, etc.) in the AKD parameters to 1.

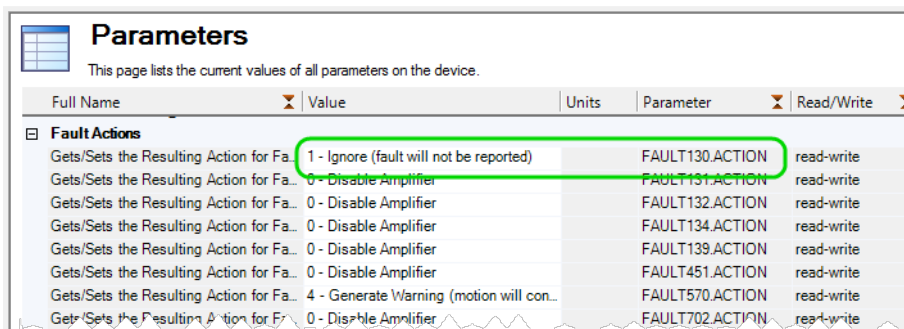

10.7.2 Error Management

When a non-fatal error occurs and motion must be stopped quickly these procedure can be taken:

10.7.2.1 Axis Procedures

Step	Example Application Code
Send Stop Command for each axis.	MLAxisStop (PipeNetwork.AXI_A1_Axis, TRUE, DEF_A1_StopDec);
Stop the Axis Motion Generator.	MLAxisMoveVel (PipeNetwork.AXI_A1_Axis, 0.0);
Wait for Axis to be stopped.	AxisStatus := MLAxisStatus (PipeNetwork.AXI_A1_Axis); IF AxisStatus.11 THEN MLAxisStop (PipeNetwork.AXI_A1_Axis,FALSE,DEF_A1_StopDec);
Turn power off(disable) all the axes.	MLAxisPower (PipeNetwork.AXI_A1_Axis,FALSE);
Disconnect Pipe Network from the axis.	MLCNVDisconnect (PipeNetwork.CNV_A1);

10.7.2.2 Machine Procedures

Step	Example Application Code
Stop Command at the master block level.	MLMstRun MLMstRun (PipeNetwork.MASTER, 0.0);

Step	Example Application Code
Wait for Master command to be stopped.	<pre> IF A1_AckState = DEF_StateErrorStop AND A2_Ackstate = DEF_StateErrorStop AND MLBlkIsReady(PipeNetwork.MASTER) THEN Printf('*** ErrorStop M1=%i ***', M1_ StatusWord, 0, 0, 0); M1_AckState := DEF_StateErrorStop; </pre>

NOTE

This code is only applicable to Pipe Network applications. It does not work in a PLCopen application.

This procedure for error management is based on the **Project Structure Guidelines** described in Application Software Structure - Implementation (→ p. 627).

See Restarting Motion with Pipe Network (→ p. 576) about restarting the motion.

10.7.3 Fast Inputs

Fast (or high-speed) Inputs are digital inputs of a drive that are configured to latch the time at which they are triggered.

- Fast Inputs allow a high-speed application to get position information about the occurrence of an external event at a higher resolution than the cycle time.
- Because of the precise timing of external events, an application can improve its control algorithm, resulting in higher operating performance.
- A position or time capture can be triggered either by the positive (rising) edge or by the negative (falling) edge of the digital input.
 - The "AKD Drive Configuration" (→ p. 817) has two capture engines which can be freely linked to any input.
 - These high speed inputs are used in applications which, when triggered, cause a drive position to be captured and reported back to the controller.

NOTE

Only digital inputs 1 and 2 can be used as Fast Inputs.

ⓘ IMPORTANT

When using S300 or S700, Fast Inputs must be enabled by setting the drive keywords IN1MODE to 26 and IN2MODE to 26.

This can be achieved using DriveGUI configuration tool.

10.7.3.1 Fast Inputs with Pipe Network Motion

↖ TIP

For the Axis and Trigger Pipe Network blocks, see MLAxisCfgFastIn.

This function arms a Fast Input and returns the latched timestamp when the Fast Input event occurs.

Registration Operation	Homing Operation
Related FB (Trigger FB)	Related FB (Axis FB)
MLTrigReadPos	MLAxisCfgFastIn
MLTrigIsTriggered	MLAxisIsTriggered
MLTrigSetEdge	MLAxisRstFastIn

When the input is triggered, the timestamp is latched.

- With EtherCAT, the timestamp sent to the KAS-IDE via the MLAxisTimeStam or MLTrigReadTime function blocks is based on the distributed clock that manages the reference clock.
 - See "Distributed Clock (Synchronization)" (→ p. 789).
- The KAS-IDE converts this timestamp into a relative offset inside the cycle.
- It is also possible to configure a Fast Input to latch the motor position instead of latching the time.
 - See "AKD Drive Configuration" (→ p. 817).
- However, when working with KAS, time latching is more useful, because the positions of all the drives in the application can then be interpolated using the [Trigger](#) block with the MLTrigReadPos function block.

10.7.3.2 Fast Inputs with PLCopen Motion

For PLCopen, see MC_TouchProbe.

This function block arms a Fast Input and returns the latched position when the Fast Input event occurs.

Other PLCopen function blocks include:

Registration Operation	Homing Operation
MC_MachRegist	MC_Reference
MC_MarkRegist	MCFB_StepAbsSwitchFastInput
	MCFB_StepLimitSwitchFastInput

10.7.4 Interpret a Timestamp

The timestamp is based on the EtherCAT system time.

For this value to make sense, the distributed clock must be activated in the drive (see "Distributed Clock tab" (→ p. 354)) and in the EtherCAT master.

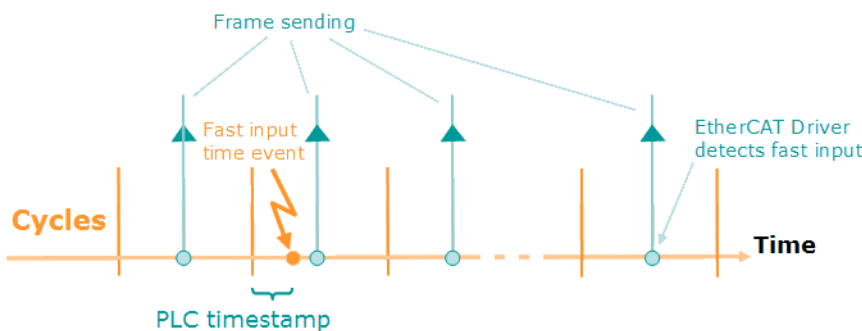

Figure 11-5: PLC Timestamp Related to Fast Input Event

- The timestamp returned is relative to the beginning of the cycle in which the Fast Input is triggered.
- It is called PLC timestamp because it is the value used in PLC programs.

10.7.5 Overtravel Conditions

The PLCopen and Pipe Network motion engines can respond to overtravel conditions from the AKD and AKD2G drive family.

- As a safety feature, AKD and AKD2G drives ignore motion commands once an overtravel is detected in the direction of a hardware limit switch.
- The PLCopen or Pipe Network motion engine applies a stop action to axes when these overtravel conditions occur.

Notes

- Generation 1 AKD drives require setting a fieldbus parameter to enable this behavior.
- The default behavior of the motion engine can be modified by setting these Axis Boolean parameters:
 - Pipe Network = ML_AXIS_PARAM_IGNORE_DRIVE_LIM_STATUS.
 - PLCopen = MC_AXIS_PARAM_IGNORE_DRIVE_LIM_STATUS.
- When this parameter is set to TRUE, the motion engine:
 - Ignores the DS-402 status word Bit 11 from the drive.
 - Allows the application to take the appropriate action.
- See "Configuring Generation 1 AKD Drives" (→ p. 554).

10.7.5.0.1 Configuring Generation 1 AKD Drives

When using generation 1 AKD drives, bit 14 of the parameter FBUS.PARAM05 must be set high to allow KAS-IDE to respond to the hardware limit switches.

See FBUS.PARAM1 TO FBUS.PARAM10.

If FBUS.PARAM05 originally had a value of 0, typing `FBUS . PARAM05 16384` would turn on bit 14. Remember to save your drive parameters to flash memory once bit 14 is set, otherwise the behavior will turn off once the drive is power cycled.

10.7.5.1 Coordinated Motion Behavior

An axis that is part of an axes group issues an emergency stop on the axes group when it experiences an overtravel condition. All axes remain enabled under servo control once the emergency stop action completes. This action puts the axes group into an error state.

To recover from this state:

1. Call MC_GrpReset on the axes group
2. Check the states of the I/O points configured for the positive and negative limit switches on the drives associated with the axes to figure out which axis and which limit switch cause the error.
3. Command motion in the direction opposite to what was previously commanded.

10.7.5.2 Pipe Network Behavior

A Pipe Network axis issues a stop action on the axis when it experiences an overtravel condition.

- This is similar to calling MAxisStop.
- Bit 11 of MAxisStatus is set and the axis remains enabled under servo control once the emergency stop action completes.
- The axis no longer accepts pipe positions.
- The pipe the axis is connected to continues functioning as before and any master will continue generating new positions.
- The axis which experienced overtravel simply no longer responds to new pipe positions.

To recover from this state, call MAxisReAlign to realign the axis with the pipe. See the page "Restarting Motion with Pipe Network" (→ p. 576) to understand how to accomplish this.

NOTE

If a hardware limit flag is being triggered at the program startup by a Pipe Network axis, MAxisReAlign may need to be called immediately before motion occurs. In this case, the distance to travel should be at least as long as the maximum distance the hardware limit flag can remain active.

10.7.5.3 PLCopen Behavior

A PLCopen axis issues an emergency stop of the axis when it experiences an overtravel condition.

- The axis remains enabled under servo control once the emergency stop action completes.
- This action puts the axis into the **ErrorStop** state.
- See "PLCopen State Machine" (→ p. 781).

To recover from this state:

1. Call MC_ResetError on the axis.
2. Command motion in the direction opposite to what was previously commanded.

If you are uncertain about which direction the axis was traveling in, check the states of the I/O points configured for the positive and negative limit switches on the drive.

10.7.6 PLC Online Change

ⓘ IMPORTANT

The project must be saved (📁) and compiled (✅) before doing an online change.

This section provides a detailed description of the PLC Online Change functionality.

See "Using PLC Online Change" (→ p. 560) for more information about using this functionality.

10.7.6.1 What is Online Change

Online Change enables you to update your PLC application on the fly, while it is running on the controller. You do not need to stop the controller, download the new code and start again. You only need to modify, recompile and download the new code as shown in the figure below; and then ask the controller to switch the execution to the new application.

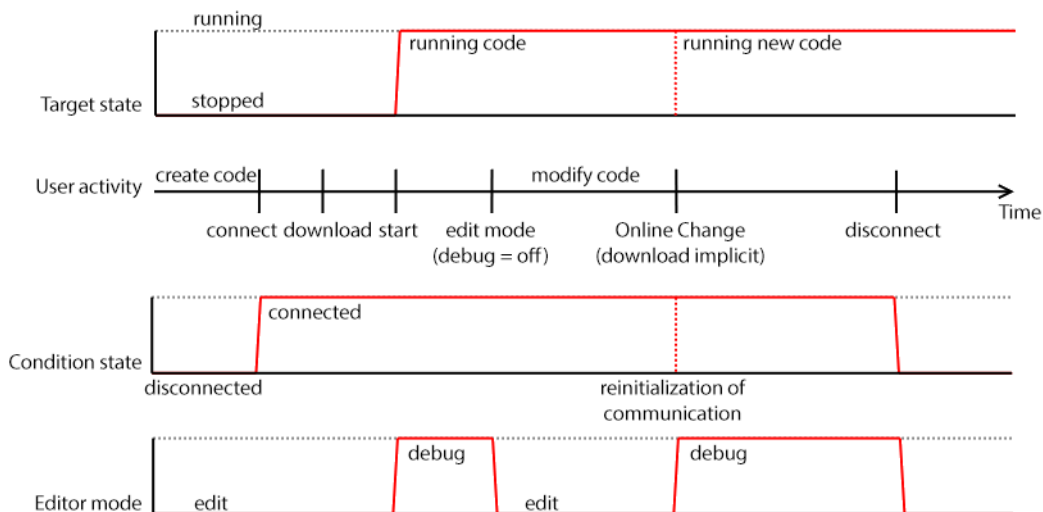

Figure 11-6: Online Change - Process Diagram

🔑 TIP

This capability applies only to PLC code. This is not supported in the Pipe Network editor, the PLCopen axis, or any other part of the system.

NOTE

Depending on the PLC code size, the time to perform the Online Change operation can take more than one [cycle](#).

In that case, you can miss one PLC cycle before the changeover becomes effective.

This duration is also displayed in the [Log](#) window with this **INFO** level message: **Online Change done in X µs**.

The INFO measurement corresponds to the duration for the code hotswap.

The download and loading of new code in memory is not taken into account in this measurement because they occur when the previous code is still running.

This feature is used in these situations:

- **Development Phase**
 - Modify the application and apply these modifications incrementally without stopping the controller.
- **Update in production**
 - Update the running motion application (e.g., with a bug fix release) without stopping the whole production chain.

When Online Change is enabled, you can perform these kinds of changes on the fly:

- Rename a program.
- Change the code of a program.
- Change the condition of an SFC transition or the actions of an SFC step .
- Create, rename, or delete global and local variables.
- Create, rename, or delete global and local function block instances.
- Rename "Retain Variables" (→ p. 707).

These changes **are not allowed**:

- Create or delete a program.
- Add or remove Custom Libraries.
- Add new PLC axes, change or delete PLC axes.
- Add new cam profiles, change or delete existing cam profiles.
- Add new Pipe Network blocks, change or delete existing Pipe Network blocks.
- Add or remove variables in a Structure.
- Create a new Structure or a new UDFB.
- Change the local parameters and variables of a UDFB.
- Change the type or dimension (or string length) of a variable or function block instance.
- Create or delete Retain variables (their position in the runtime cannot be re-allocated).
- Change SFC charts: you cannot add or remove steps in the First Level of an SFC chart.
 - You can modify existing steps.
- Change the set of Input/Output or any modification that leads to an update in the [EtherCAT Motion Bus configuration](#).
- Pulse (P or N) contacts and coils (edge detection).

TIP

Using Pulse contacts in FFLD does not give any error, but the behavior of the contact during the switch is not always safe.
See [click here...](#) for more information and a workaround.

- The WAIT / WAIT_TIME instructions must not be used.

IMPORTANT

The Online Change and Revert functions will fail while executing a WAIT.

- Loops in FBD with no declared variable linked.
 - In this case, you must explicitly insert a variable in the loop.

IMPORTANT

When Online Change is enabled and [custom libraries](#) are used, some errors can occur during the compilation. This happens if you open your project on another PC or under a different user account in Windows.

To fix this limitation:

1. Deactivate the Online Change.
2. Save and then reopen the project.
3. Re-enable the Online Change.

NOTE

Your new application can contain more variables than the previous one.
A memory with sufficient pre-allocated space is defined for the eventual new variables.
If you exceed this limit, a warning message opens.

For limitation about breakpoint with Online Change, see "Online Change" (→ p. 233).

[About the States and Transitions](#)

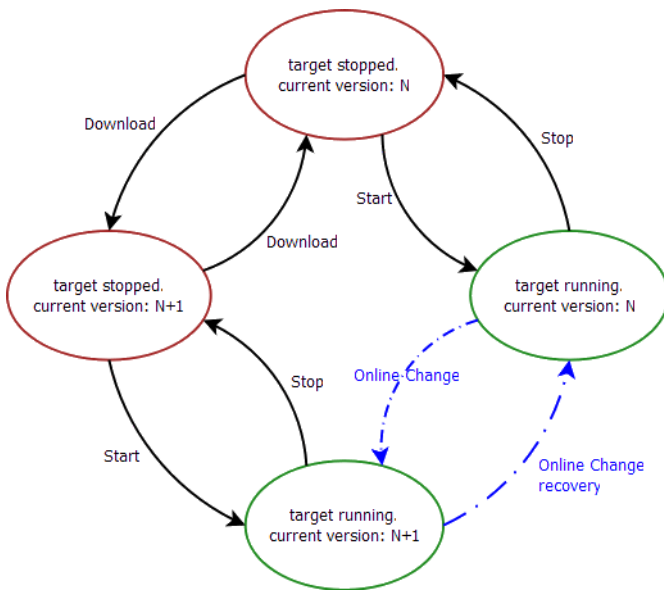

Figure 11-7: Online Change - States and Transitions

10.7.6.2 Activate an Online Change

To allow Online Change, you need to open the PLC options and set the relevant parameters.

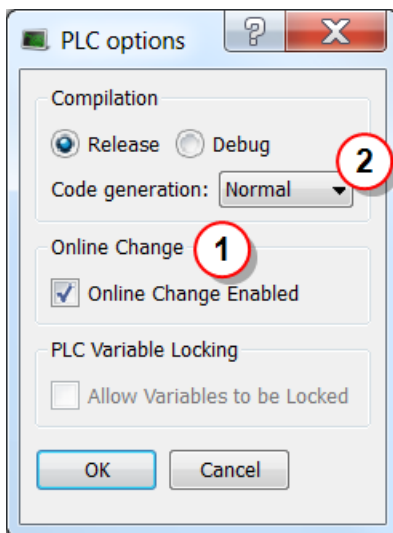

Figure 11-8: PLC Options - Online Change Enable

10.7.6.2.1 Set the Parameters

This box allows you to enable or disable the **Online Change** feature (see call out **1**).

ⓘ IMPORTANT

If you deactivate the Online Change, the next PLC application generated is no more compatible for an online change, even if you re-activated the online change before the compilation.

As a result, you can only apply an Online Change to a running application under these conditions:

- The Online Change was already activated.
- You have never deactivated the Online Change between the compilation of the running application and the compilation of the new application.
 - Check the [Controller Log](#) window for any errors that occur.

Verify the **Normal** code **2** is selected because Online Change is not possible with **Optimized** code.

When **Optimized** code is selected, then Online Change is always deactivated.

Then you can compile the application; this now allows future changes on the fly.

10.7.6.2.2 Switch to Edit Mode

When you start the application, the Debug mode is automatically activated.

- You can see the values changing in the editors and the Dictionary, showing what is happening on the controller.
- In this mode, the editor is read-only, so you are not able to modify the code.

To edit your code, go out of the Debug mode and enter the Edit mode by clicking the () button in the "Main Toolbar" (→ p. 255).

Perform the Online Change

When your new code has compiled correctly, you can perform the Online Change. To do so, click the  button. When you click this button, the KAS-IDE opens a window showing the execution of current actions (download, activation of new code).

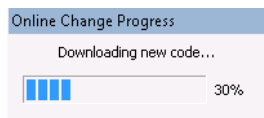

Figure 11-9: Online Change - Updating Controller Version

Once the Online Change is applied, the result is displayed in the window and you can click OK to acknowledge the operation and do a

Warm start.

10.7.6.2.3 Dictionary Behavior

When the Online Change is enabled, the dictionary shows:

- new variables in blue
- deleted variables in red

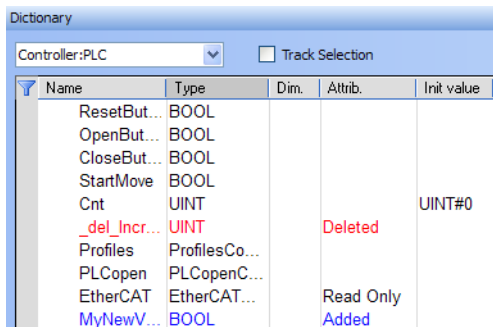

Figure 11-10: Online Change - Dictionary

TIP

The deleted variables can be used for new variables.

10.7.6.3 The Revert Button

The **Revert** button is for security purposes.

- It's used, after an Online Change, to revert the change quickly and return to the previous application.
 - That means switching the execution of the controller to the [P-code](#) that was running before the last Online Change.
 - The source code in the KAS-IDE is not replaced.
 - The WAIT / WAIT_TIME instructions can not be used with **Revert**.

After the Revert, the KAS-IDE automatically goes back to Edit mode and is disconnected from the controller. the controller must be manually reconnected.

NOTE

You can go back to the previous version only when the Online Change feature is activated and while the controller is not stopped.

ⓘ IMPORTANT

After a revert operation, the Online Change feature is **deactivated**.

The Revert button is active when you are connected and the controller is running.

Revert is not possible:

- If you did not perform an Online Change.
- If the controller has been restarted since the previous Online Change.
- After another Revert.
- During a WAIT.

10.7.6.4 Difference between Local and Controller Versions

When you restore a project with the Revert feature after an Online Change, KAS provides a tool to show the differences between two versions of the project.

This tool can help:

- In checking all modifications before the next Online Change.
- Compare the code with the last version after a Revert.

See "Compare PLC Programs" (→ p. 239) for more information.

10.7.6.5 Pulse Limitations with Online Change

At the first cycle, the pulse evaluation is ignored, and the memory is updated. This memory enables the pulse evaluation from the second cycle.

When we apply the Online Change between t_0 and t_1 , the cases where this method is not correct are the two following:

- When we want to detect a **falling** edge:

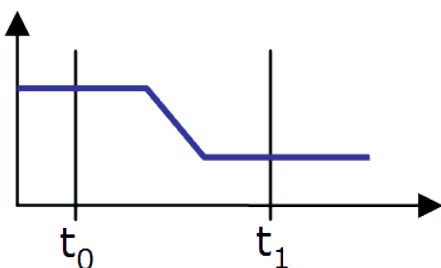

Figure 11-11: Pulse Limitations with Falling Edge

- When we want to detect a **rising** edge:

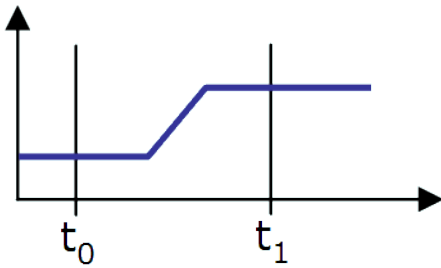

Figure 11-12: Pulse Limitations with Rising Edge

TIP

If you want to avoid this limitation, you must use declared instances of R_TRIG and F_TRIG function blocks.

NOTE

This limitation is temporary and is going to be fixed in a future release.

10.7.6.6 Using PLC Online Change

This section provides an overview of how to use Online Change.

See "PLC Online Change" (→ p. 555) for descriptions of the functionality.





10.7.6.6.1 Set up an Application

1. Create a new PLC application.
2. Connect to a controller and scan for EtherCAT devices.
3. Add logic and function blocks to the application.
4. Compile the project ,

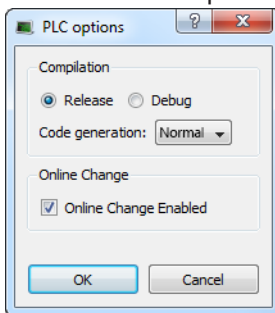

10.7.6.6.2 Enable Online Change

1. Select the PLC Options button from the tool bar.



2. Enable Online Change.
3. Compile the project , connect  and download  the application to the device.
4. Start executing the application. 

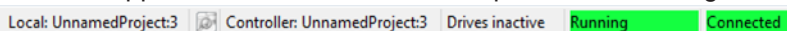

10.7.6.6.3 Using Online Change

1. Enable the Toggle Edit/Debug mode button in the tool bar.  → 
- Note that application variables will not be updated, even though the application is running.

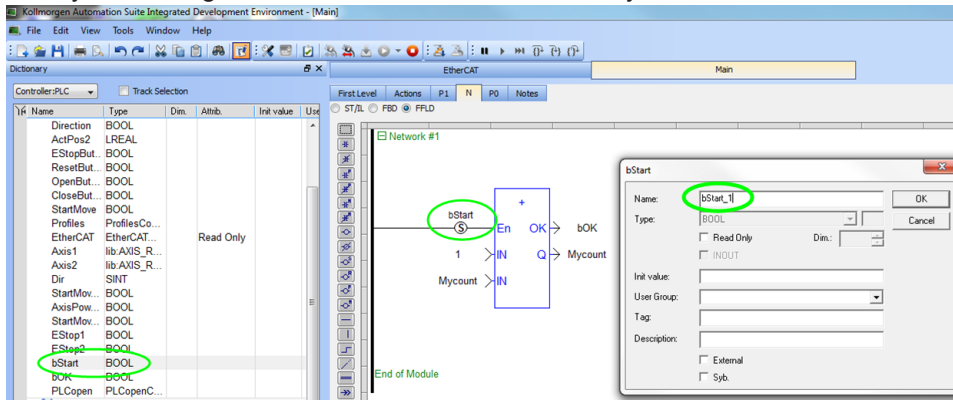

2. Modify a local or global variable name in the Dictionary.



3. Compile  and click the PLC Online Change download button  from the tool bar to download the changes to the controller.
 Note that the status bar has changed from "Running" to "Paused" during the download, and back to "Running" once the download has finished.
 The applications variables should be updating.

NOTE

If Online Change is disabled while the application is running, even temporarily, downloading will fail.

10.7.6.6.4 Revert Online Change

1. Click the PLC Online Change Revert button .
2. A message appears stating that revert was successful.
3. Note the reverted state of the application in the IDE.

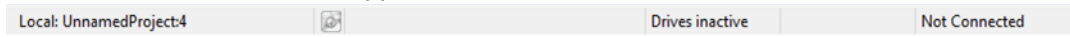

4. Connect to the device. 
5. Note the state of the application and the device.

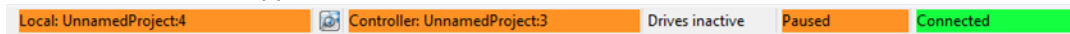

6. From this state, Online Change can only be used again after ...:
 1. Stopping the application
 2. Making changes
 3. Recompile
 4. Download the application to the controller

10.7.7 PLCopen Homing

10.7.7.1 PLCopen Homing Description

The homing features provided in PLCopen create tools for homing of PLCopen axes. Homing may be performed utilizing the MC_Reference function block, utilizing Custom Homing Library UDFB's or by writing your own homing cycles.

- Utilizing MC_Reference
 The application specifies a position for an axis to be assigned to a reference position, then invokes the MC_Reference function block to generate motion to move the axis to the reference location. The AKD capture engine (previously set up by the application via SDO commands) captures the position of the reference location. Based on the desired reference position and the captured actual position, the coordinate system is shifted to correlate the desired reference position to this location.
- Writing your own homing cycles
 UDFBs can be written to provide specific "canned" homing cycles based on feedback type, and desired homing sequences such as homing off of limit switches, encoder markers, homing to "zero" or null

positions etc. by proper configuration of the AKD capture engine, the MC_Reference and MC_SetPositionMC_SetPos function blocks.

- Utilizing Custom Libraries

A library already contains a set of homing UDFB. Contact the [Support](#) for more information. To add the library to your project, refer to "Create and Use Custom Libraries" (→ p. 209)

10.7.7.2 PLCopen Homing Methods

The following common homing methods (among others) can be performed in PLCopen. This section details the setting of the ADK parameters and the PLCopen function blocks to accomplish these methods.

PLCopen does not limit you to these methods, as the capture engine is very configurable.

10.7.7.2.1 Home using Current Position

Homing using the current position is simply accomplished using the MC_SetPositionMC_SetPos function block. Using this function block, the current position can be set to any value.

10.7.7.2.2 Find Input

Homing using a drive input is accomplished by configuring the [AKD capture engine](#), and then using the MC_Reference function block. The following capture engine parameters need to be configured, along with the following input parameters in the MC_Reference.

- Capture Event has to be set to ignore preconditions (0)
- Capture edge – capture edge is programmed in the MC_Referece block
- Capture Trigger must be set to the desired drive input (0-6)
- Capture mode must be set to capture position (0)
- Capture preselect is not used
- Capture Precondition edge is not used
- MC_Reference inputs:
 - Trigger_Ref.InputID must be set to 0 or 1 to select which AKD capture engine to use
 - Trigger_Ref.Direction must be set to Rising (1) or Falling (2) to select Capture Edge
 - Trigger_Ref.Trigid is not required.
 - Position input must be programmed to the desired position at the switch.
 - Option input must be programmed to 0 for "use latched position".

10.7.7.2.3 Find Input then find Zero Angle

Homing using a drive input along with the zero angle is similar to "Find Input" except the position is defined at the zero angle of the feedback device, rather than the switch location. It is typically used for resolver feedback.

- Capture Event must be set to ignore preconditions (0)
- Capture edge – capture edge is programmed in the MC_Referece block
- Capture Trigger must be set to the desired drive input (0-6)
- Capture preselect is not used
- Capture Precondition edge is not used
- Capture mode must be set to capture position (0)
- MC_Reference inputs:
 - Trigger_Ref.InputID must be set to 0 or 1 to select which AKD capture engine to use.
 - Trigger_Ref.Direction must be set to Rising (1) or Falling (2) to select switch capture edge.
 - Trigger_Ref.Trigid is not required.
 - Position input must be programmed to the desired position at the null closest to the switch.
 - Option input must be programmed to identify the number of poles the resolver has.

10.7.7.2.4 Find Input then find Index

Homing using a drive input along with the index is similar to "Find Input" except the position is defined at the index pulse of the feedback device, rather than the switch location. It is typically used for incremental encoder feedback. To accomplish this, a precondition is used in the capture engine. Specifically, the input is the precondition, and the index is the event. The reference method looks for the switch first, and then the index pulse.

- Capture Event must be set to the desired switch operation. Typically set to 1 to require the edge of the switch. Set to 2 or 3 if the state of the switch is required.
- Capture preselect must be set to the desired drive input (0-7)
- Capture edge – capture edge of index pulse is programmed in the MC_Referece block
- Capture Trigger must be set to the desired index input (10 = primary index, 11 = tertiary index)
- Capture mode must be set to capture position (0)
- MC_Reference inputs:
 - Trigger_Ref.InputID must be set to 0 or 1 to select which AKD capture engine to use
 - Trigger_Ref.Direction must be set to Rising (1) or Falling (2) to select Capture Edge
 - Trigger_Ref.Trigid is not required.
 - Position input must be programmed to the desired position at the index pulse.
 - Option input must be programmed to 0 for "use latched position".

10.7.7.2.5 Find Index

Homing using a drive index pulse is accomplished by configuring the AKD capture engine, and then using the MC_Reference function block. The following capture engine parameters need to be configured, along with the following input parameters in the MC_Reference.

- Capture Event must be set to ignore preconditions (0)
- Capture edge – capture edge is programmed in the MC_Referece block
- Capture Trigger must be set to the desired index input (10 = primary index, 11 = tertiary index)
- Capture mode must be set to capture position (0)
- Capture preselect is not used
- Capture Precondition edge is not used
- MC_Reference inputs:
 - Trigger_Ref.InputID must be set to 0 or 1 to select which AKD capture engine to use
 - Trigger_Ref.Direction must be set to Rising (1) or Falling (2) to select Capture Edge
 - Trigger_Ref.Trigid is not required.
 - Position input must be programmed to the desired position at the index pulse.
 - Option input must be programmed to 0 for use latched position.

10.7.7.3 AKD Capture Engine Configuration

The AKD capture engine provides a broad range of capabilities for configuration of the capture events.

- It is capable of configuring preconditions to allow the application programmer to specify sequential events or conditions that must be met before the capture event can be triggered.
- The capture Engine in the AKD is configured with SDO #0x3460 (subindexes 1 to 10).
- The AKD supports two capture engines (0 and 1); the application programmer must configure the desired engine.

Sub Index #	Function
1	Trigger for capture engine 0.
2	Trigger for capture engine 1.
3	Mode for capture engine 0.
4	Mode for capture engine 1.
5	Capture Event for capture engine 0.
6	Capture Event for capture engine 1.
7	Precondition edge for capture engine 0.
8	Precondition edge for capture engine 1.
9	Preselect for capture engine 0.
10	Preselect for capture engine 1.

10.7.7.3.1 AKD Configuration Parameters

These are the configuration parameters for the ADK capture engines.

For more details, see either CAP0.PRESELECT or CAP1.PRESELECT.

Parameter	Description
Capture Edge	Programmed in the MC_Reference function block.
Capture Event (SDO object #0x3460 subindex engine 0 = 5/engine 1 = 6)	<ul style="list-style-type: none"> • 0 = Ignore preconditions. • 1 = Trigger edge after the precondition edge. • 2 = Trigger edge while precondition = 1. • 3 = Trigger edge while precondition = 0.
Capture Mode (SDO object #0x3460 subindex 3/4)	<ul style="list-style-type: none"> • 0 = Capture position. • 1 = Capture internal time. • 2 = Capture EtherCAT distributed time (DCT). • 3 = Capture zero angle position.
Capture Precondition Edge (SDO object #0x3460, subindex 7/8)	<ul style="list-style-type: none"> • 0 = Reserved. • 1 = Precondition with rising edge. • 2 = Precondition with falling edge. • 3 = Precondition with rising and falling edges.

Parameter	Description
Capture Preselect (SDO object #0x3460 subindex 9/10)	<ul style="list-style-type: none"> • 0 = General input 1. • 1 = General input 2. • ... • 6 = General input 7. • 7 = rs485 input 1. • 8 = rs485 input 2. • 9 = rs485 input 3. • 10 = Primary index. • 11 = Tertiary index.
Capture Trigger (SDO object #0x3460 subindex 1/2)	<ul style="list-style-type: none"> • 0 = General input 1. • 1 = General input 2. • ... • 6 = General input 7. • 7 = rs485 input 1. • 8 = rs485 input 2. • 9 = rs485 input 3. • 10 = Primary index. • 11 = Tertiary index.

10.7.8 Pipe Network Homing

UDFBs can be written to provide specific "canned" homing cycles based on feedback type. Contact the [Support](#) for more information.

10.7.8.1 Fast Homing Example with the Pipe Network Motion Engine Axis Pipe Block

This use case explains how to use the motion library functions of the axes when you want to detect the positive edge of the first Fast Input in the drive, and read its associated timestamp. `MLAxisIsTriggered` can be used to accurately perform a homing procedure in a user-defined procedure.

A Setup sequence example.

1. `MLAxisCfgFastIn(PipeNetwork.AXIS1, MLFI_FIRST, MLFI_RISING_EDGE)`
 - Configure Fast Input 0 of AXIS1 to be triggered on the positive edge.

NOTE

Since `tMLFI_FIRST` and `MLFI_SECOND` correspond to the physical Fast Inputs 1 and 2. Therefore the drive must be configured in order to link fast input 1 with engine 0, and fast input 2 with engine 1.

- The first argument indicates the Axis pipe block in the Pipe Network that represents the drive to be configured
 - The second argument identifies which of the two Fast Inputs of the drive is configured (can be 0 or 1)
 - The third argument can indicate detection of positive edge when set to 1 and detection of negative edge when set to 2
Note that if set to 0, Fast Input is disabled
2. `MLAxisIsTriggered(PipeNetwork.AXIS1, 0, 1)`
 - This function returns true if Fast Input 0 of AXIS1 has been triggered on the positive edge.
 - The meaning of the arguments is the same as in `MLAxisCfgFastIn`
 3. `MLAxisTimeStamp(PipeNetwork.AXIS1, 0, 1)`
 - This function returns the time in microseconds when the Fast Input was triggered on the positive edge
This time is relative to the start of the drive cycle time and its value is explained in the section "Interpret a Timestamp" (→ p. 553).
 - The meaning of the arguments is the same as in `MLAxisCfgFastIn`
 4. `MLAxisRstFastIn(PipeNetwork.AXIS1, MLFI_FIRST)`
 - This function resets the Fast Input 0 of AXIS1. The reset keeps the configuration of the Fast Input, but it rearms it so it can be triggered again

- The meaning of the first two arguments is the same as in MLAxisCfgFastIn

5. Follow-up Motion

The following is typical code used in a homing procedure.

```

CASE StepCounter OF

0:

MLAxisRstFastIn(PipeNetwork.Feeder,MLFI_FIRST);

MLAxisMoveVel(PipeNetwork.Feeder,250.0); //Jog Feeder Axis to search for
sensor input

StepCounter := 1;

1:

IF MLAxisIsTriggered(PipeNetwork.Feeder,MLFI_FIRST,MLFI_RISING_EDGE)
    THEN MLAxisAbs(PipeNetwork.Feeder,MLAxisCmdPos(PipeNetwork.Feeder));
//Stop motion when sensor is reached
    StepCounter := 2;
END_IF;

2:

IF MLAxisGenIsRdy(PipeNetwork.Feeder)
    THEN MLAxisWritePos(PipeNetwork.Feeder,0); //Set Feeder Axis position to
zero
    StepCounter := 3;
END_IF;

```

Fast Homing based on the drive's high speed capture mechanism is also supported by the following Kollmorgen KUDFBs in the IDE Function Block Library: MLFB_HomeFindHomeFastInput, MLFB_HomeFindHomeFastInputModulo, MLFB_HomeFindLimitFastInput, and MLFB_HomeFindLimitFastInputModulo.

The Axis Position can also be derived from the Time Stamp by with the following code:

```

TimeStamp := any_to_lreal(MLAxisTimeStamp( iAxisID, any_to_dint
(ibFastInputNumber), 1+any_to_dint(ibHomeSwitchMode) ))/1000000;
CalculatedTriggerPosition := (CurrentVelocity-
PreviousVelocity)/2/iCycleTime*TimeStamp*TimeStamp+PreviousVelocity*TimeStamp
+PreviousPosition;

```

10.7.9 PLCopen Registration

Registration is a technique used to maintain the positional accuracy in repetitive processes.

- It uses a Fast Input switch, typically a photo eye, to measure product position and adjust the axis (or axes) to compensate for variations.

- The basic forms of registration are:
 - "Master/Slave Registration" (→ p. 569)
 - "Single-Axis Registration" (→ p. 570)

10.7.9.1 Decide which Function Blocks to Use for Registration

These are the methods to set up Registration, each using a different set of function blocks.

Method 1 is easy to set up, thus we recommend trying it first.

	Method 1: Using MC_TouchProbe	Method 2: Using MC_MarkRegist or MC_MachRegist
Key Function Blocks	<ul style="list-style-type: none"> • MC_MoveSuperimp • MC_TouchProbe • Trigger_Ref structure 	<ul style="list-style-type: none"> • MC_MachRegist • MC_MarkRegist • MC_MoveSuperimp • MC_ReadParam • Trigger_Ref structure
Details	<p>This method incorporates:</p> <ul style="list-style-type: none"> • MC_TouchProbe to capture the drive position using the high speed capture engine in the drive. • The Trigger_Ref structure is used to set up the drive's capture engine. • MC_TouchProbe outputs a signal when a capture has occurred and also the position captured. • Additional code is created to make motion corrections (typically with MC_TouchProbe) based on the captured position value compared to a reference position or distance. 	<p>This method incorporates:</p> <ul style="list-style-type: none"> • MC_MarkRegist or MC_MachRegist which, in addition to capturing a position from a drive, automatically calculates the position correction. • This can either: <ul style="list-style-type: none"> • Make the offset move (linear acceleration / deceleration). • Outputs the calculated position correction to be done by another function block (typically with MC_TouchProbe). • The Trigger_Ref structure is used to set up the drive's capture engine.
Advantages	<p>Basic implementation.</p> <ul style="list-style-type: none"> • Fast to develop due to having fewer input values to determine . • Simple function block functionality leads to less debug time. 	<p>Incorporates additional functionality including:</p> <ul style="list-style-type: none"> • Automatically calculates the number of good and bad registration marks. • The option to only make corrective moves based on a good registration mark. • Automatically make the corrective motion (linear acceleration / deceleration only). • Position scaling differences are internally calculated if the axis in which the position is captured and the axis in which the motion compensation is made are different.
Example	PLCopen Registration Example Project	Rotary Knife Simulated Application

10.7.9.2 Master/Slave Registration

Master/slave registration is performed on an axis running a master/slave move (e.g., MC_CamIn or MC_GearIn).

- It can be performed by tracking the position of the master axis (Master Registration) or tracking the position of the slave axis (Slave Registration) or both.
- This type of registration:
 - Adjusts the positional relationship between the master and slave axes to accommodate for variations in the distance between products.
 - Keeps the process synchronized to the product over many repetitions.

10.7.9.2.1 Master Registration

Master registration is performed by having the Fast Input switch trigger on a registration mark controlled by the master axis.

- When the Fast Input latches the position of the master axis at this mark, the distance between this position and the position of the previous mark is compared to an expected distance.
- This difference is added to the slave axis's master offset to adjust the position of the slave axis with respect to the position of the master.

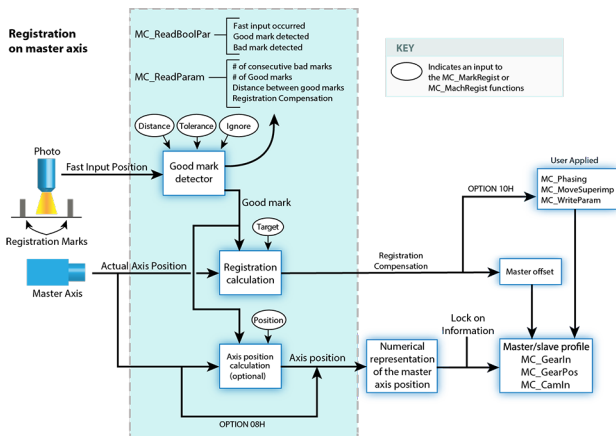

10.7.9.2.2 Slave Registration

Slave registration is performed by having the Fast Input switch trigger on a registration mark controlled by the slave axis.

- When the Fast Input latches the position of the slave axis at this mark, the distance between this position and the position of the previous mark is compared to an expected distance.
- This difference is added to the slave axis's slave offset to adjust the position of the slave axis with respect to the position of the master.

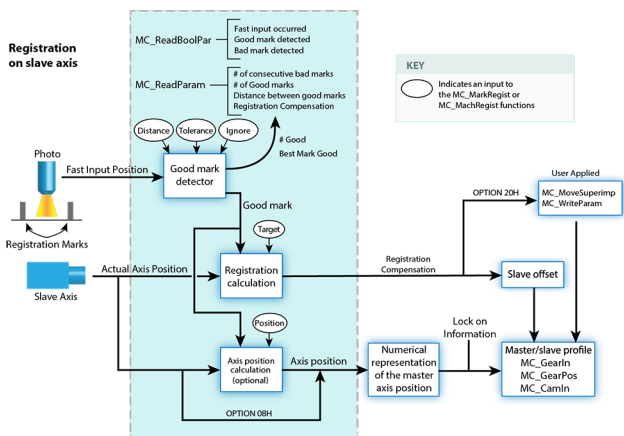

This "Registration" (→ p. 570) image is an example of a printing application using registration.

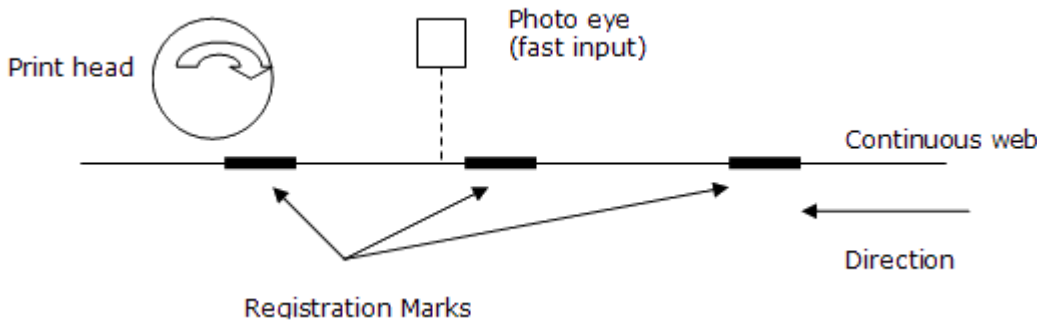

Figure 11-13: Registration

- The axis controlling the web is the master and the axis controlling the print head is the slave.
 - When the photo eye detects a registration mark on the web, the master position is latched.
- The amount of registration compensation required is calculated by comparing the actual distance between the marks to the expected distance.
 - That difference is added to the slave axis's master offset.
 - This adjusts the positional relationship between the web and the print head so that each print on the web is placed accurately.

10.7.9.3 Single-Axis Registration

Single-axis registration is performed on an axis running a discrete move such as MC_MoveAbsolute or MC_MoveRelative.

- When the Fast Input latches the position of the product, the axis position is reset, typically to 0 (zero).
- This resets the axis's coordinates for each product to accommodate for variations in the distance between products and keep the process synchronized to the product over many repetitions.

10.7.9.4 Registration Application Guide

In many closed-loop servo systems it is often necessary to maintain synchronization and accurate positioning repeatedly throughout a process. This can be difficult when the product or process itself is inconsistent. Using registration helps you to overcome this difficulty.

Many factors can contribute to inconsistency. Some examples are:

- Working with non-rigid material which may stretch or shrink during processing.
- Working with the mechanics of a system where the revolution of a feedback device may give you, for example, 5975 counts on one revolution and 5974 on the next.
- Unevenly spaced products on a web or belt.
- Materials which are sensitive to temperature, humidity, pressure, etc.

To overcome the various product and process inconsistencies registration capabilities may be required and can be applied on any servo or digitizing axis, and with any move type. Typically in these applications, sensors are used to detect the position of the product. With non-rigid materials, which may stretch or shrink or are unevenly spaced, a photo eye can detect registration marks on the material. With rigid products or processes a proximity sensor can detect leading or trailing product edges for material spacing.

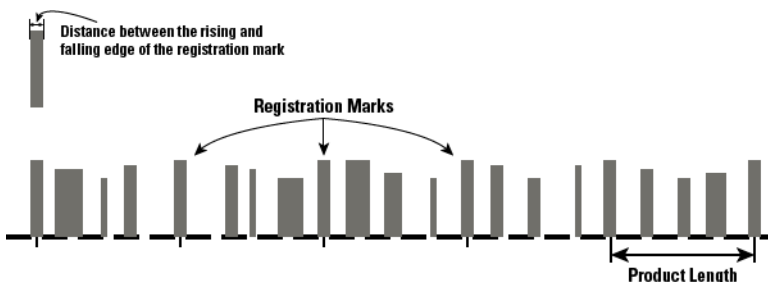

With registration, the registration sensor is wired to the fast input on the servo drive providing the means for the registration trigger that will capture the axis position at the instance of the registration event. When the event occurs, the system will calculate a registration correction to compensate for the inconsistency and then can apply the correction to the registration axis and/or change the numerical representation of the registration axis position.

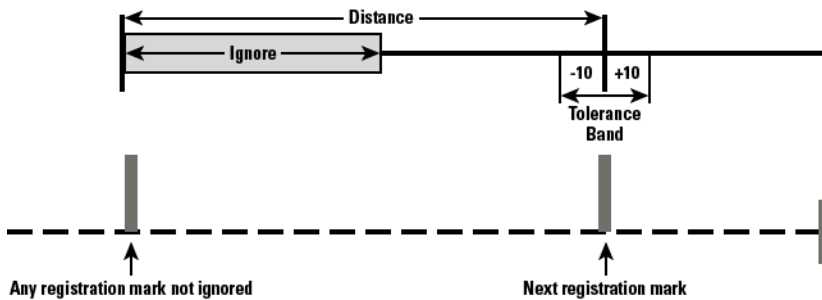

This is important in applications such as printing, packaging, and converting where the process must be precisely coordinated and any non-rigid material cannot be depended upon to retain dimensional relationships. These applications usually involve master/slave moves. Not only does registration provide correction but the fast input signals can also be used as repeatable references to which the master and all subsequent slaves continually synchronize. Two main types of registration are "Mark to Mark Registration" (→ p. 571) and "Mark to Machine Registration" (→ p. 571).

10.7.9.4.1 Mark to Mark Registration

Mark to Mark Registration is implemented with the function block MC_MarkRegist and is based on the desired distance between two registration marks. This distance is used to qualify a "good" mark and then calculate a registration correction. Examples of the different mark to mark registration variations include:

- Clear Lane Registration
- Print Registration
- Product Registration
- Rotary Registration

Clear Lane Registration is the most common type of registration used in industry. A dedicated lane on the material is reserved solely for registration purposes. Only the registration marks in the lane will trigger the sensor and fast input on the servo drive. The distance between one registration mark and the next mark is the basis for registration correction calculations.

Print Registration is less common than Clear Lane Registration. Print registration involves picking out a distinct distance between print features. Here too, this distance is the basis for registration correction calculations. Print registration is used when it is not practical to have a clear lane.

Product Registration uses cycle position where the relationship of the product position in the process cycle is important. Product registration can occur synchronously or asynchronously. In synchronous product registration, products typically flow continuously through the process. Registration will measure and calculate small adjustments required to move each product to the correct position. The distance between products is the basis for registration correction calculations. Asynchronous applications may require the axis to sit and wait for the product to pass the sensor and, when it does, initiate a move and also apply registration correction based on the position of the product.

Rotary Registration is used to maintain a fixed axis position reference point on a rotary axis that has non-integer feedback in one revolution. If the axis position is not adjusted, the actual axis position would walk away from the desired position every revolution because of the non-integer number of feedback units per revolution.

10.7.9.4.2 Mark to Machine Registration

Mark to Machine Registration is implemented with the function block MC_MachRegist and is based on a desired target position on a machine axis. Like mark to mark registration, mark to machine registration uses the desired distance between two registration marks to qualify a "good" mark (using Clear Lane, Print, and Product registration). But instead of using the mark to mark length, it uses an axis position as its basis for correction.

10.7.9.5 Fast Homing Example with the PLCopen Motion Engine

This example shows how to use the axes' motion library functions to detect the positive edge of the first Fast Input in the drive, and read its position. MC_TouchProbe and the Trig_Ref library function are used to accurately perform a homing procedure.

1. Set up an instance of the TrigRef function in the Dictionary. For this example, the name **A1_TrigRef** is used.

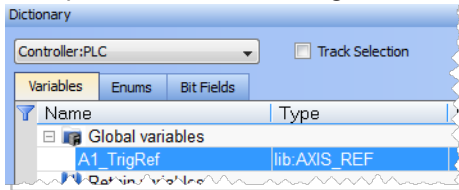

2. Define the TrigRef values.

```
A1_TrigRef.InputID := 0; // configure Drive Capture Engine Used
A1_TrigRef.TrigID := 0; // configure which Drive to capture an input
A1_TrigRef.Direction := 1; // configure Signal transition Direction of
capture
A1_TrigRef.TrigMode := 1; // configure Time or Position Capture
```

3. Activate the TouchProbe function

```
Inst_MC_TouchProbe( True, AxisID, A1_TrigRef, FALSE, 0, 0 );
```

NOTE

The position capture can be time-based (`A1_TrigRef.TrigMode := 0`) or position-based (`A1_TrigRef.TrigMode := 1`).

TIP

Fast Homing based on the drive's high speed capture mechanism is also supported by the following Kollmorgen KUDFBs in the IDE Function Block Library MCFB_StepAbsSwitchFastInput and MCFB_StepLimitSwitchFastInput.

10.7.10 Pipe Network Registration and Fast Homing

10.7.10.1 Fast Homing Example with the Pipe Network Motion Engine Axis Pipe Block

This use case explains how to use the motion library functions of the axes when you want to detect the positive edge of the first Fast Input in the drive, and read its associated timestamp. MlAxisIsTriggered can be used to accurately perform a homing procedure in a user-defined procedure.

A Setup sequence example.

1. MlAxisCfgFastIn(PipeNetwork.AXIS1, MLFI_FIRST, MLFI_RISING_EDGE)
 - Configure Fast Input 0 of AXIS1 to be triggered on the positive edge.

NOTE

Since tMLFI_FIRST and MLFI_SECOND correspond to the physical Fast Inputs 1 and 2. Therefore the drive must be configured in order to link fast input 1 with engine 0, and fast input 2 with engine 1.

- The first argument indicates the Axis pipe block in the Pipe Network that represents the drive to be configured
 - The second argument identifies which of the two Fast Inputs of the drive is configured (can be 0 or 1)
 - The third argument can indicate detection of positive edge when set to 1 and detection of negative edge when set to 2
Note that if set to 0, Fast Input is disabled
2. MlAxisIsTriggered(PipeNetwork.AXIS1, 0, 1)

- This function returns true if Fast Input 0 of AXIS1 has been triggered on the positive edge.
 - The meaning of the arguments is the same as in MLAxisCfgFastIn
3. MLAxisTimeStamp(PipeNetwork.AXIS1, 0, 1)
 - This function returns the time in microseconds when the Fast Input was triggered on the positive edge. This time is relative to the start of the drive cycle time and its value is explained in the section "Interpret a Timestamp" (→ p. 553).
 - The meaning of the arguments is the same as in MLAxisCfgFastIn
 4. MLAxisRstFastIn(PipeNetwork.AXIS1, MLFI_FIRST)
 - This function resets the Fast Input 0 of AXIS1. The reset keeps the configuration of the Fast Input, but it rearms it so it can be triggered again
 - The meaning of the first two arguments is the same as in MLAxisCfgFastIn
 5. Follow-up Motion

The following is typical code used in a homing procedure.

```

CASE StepCounter OF

0:

MLAxisRstFastIn(PipeNetwork.Feeder,MLFI_FIRST);

MLAxisMoveVel(PipeNetwork.Feeder,250.0); //Jog Feeder Axis to search for
sensor input

StepCounter := 1;

1:

IF MLAxisIsTriggered(PipeNetwork.Feeder,MLFI_FIRST,MLFI_RISING_EDGE)
  THEN MLAxisAbs(PipeNetwork.Feeder,MLAxisCmdPos(PipeNetwork.Feeder));
  //Stop motion when sensor is reached
  StepCounter := 2;
END_IF;

2:

IF MLAxisGenIsRdy(PipeNetwork.Feeder)
  THEN MLAxisWritePos(PipeNetwork.Feeder,0); //Set Feeder Axis position to
zero
  StepCounter := 3;
END_IF;

```

Fast Homing based on the drive's high speed capture mechanism is also supported by the following Kollmorgen KUDFBs in the IDE Function Block Library: MLFB_HomeFindHomeFastInput, MLFB_HomeFindHomeFastInputModulo, MLFB_HomeFindLimitFastInput, and MLFB_HomeFindLimitFastInputModulo.

The Axis Position can also be derived from the Time Stamp by with the following code:

```

TimeStamp := any_to_lreal(MLAxisTimeStamp( iAxisID, any_to_dint
(ibFastInputNumber), 1+any_to_dint(ibHomeSwitchMode) ))/1000000;
CalculatedTriggerPosition := (CurrentVelocity-

```

```
PreviousVelocity) / 2 / iCycleTime * TimeStamp * TimeStamp + PreviousVelocity * TimeStamp + PreviousPosition;
```

10.7.10.2 Registration Position Capture Example with Pipe Network Trigger Block

A Pipe Network Trigger block can be used for registration applications to capture a pipe position based on a timestamp which is set when a drive's fast input changes state. A Trigger block is placed in the Pipe Network precisely where the pipe position needs to be captured.

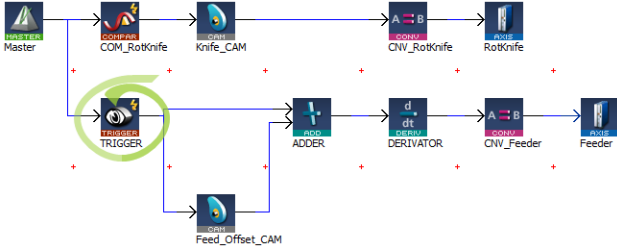

Figure 11-14: Example of using a Pipe Network Trigger block for position capture.

The Pipe Network motion engine captures the pipe position by using the timestamp received from the drive and interpolating two consecutive pipe position updates. The timestamp will have a delay getting into the pipe network from the drive (typically 1-2 cycles) due to sensor delay and the communication latency through the EtherCAT network (typically 1-2 cycles).

```
Corrected timestamp: = Fast input timestamp - DelayCompensation
```

To account for this delay, MLTrigWriteDelay provides delay compensation to the pipe position returned in MLTrigReadPos based on the expected delay.

The Trigger block is first configured by clicking on the block in a pipe network and setting the following parameters.

Function	Description
INPUT_AXIS	Defines the axis whose Fast Input is used. This name is the same given to the corresponding axis block in the Pipe Network
INPUT_ID	Indicates which one of the two available Fast Inputs in that particular axis is used. The value can be MLFI_FIRST or MLFI_SECOND for the trigger block to be triggered on the arrival of the first or the second input respectively. Specify one of the following constants : MLFI_FIRST or MLFI_SECOND for the trigger block to be triggered on the arrival of the first or the second input respectively.
TRIGGER_MODE	Indicates if the trigger block responds to the rising edge or the falling edge of the Fast Input Specify one of the following constants : MLFI_RISING_EDGE or MLFI_FALLING_EDGE

Figure 11-15: Configuration of the Trigger block

After configuring the Trigger block, the order of calls to its motion library functions is as follows:

1. MLTrigWriteDelay(DINT, TriggerID, LREAL, delay)
 - This function sets the delay compensation, typically starting with a value of 2 usec + (1 or 2) EtherCAT cycles.
2. MLTrigSetEdge(PipeNetwork.TRIGGER1, MLFI_FIRST, MLFI_RISING_EDGE)
 - This function reconfigures the edge of a trigger lock.
 - This function only needs to be called if the desired edge is different than the edge specified in configuration of the trigger block or if the edge is different than the previous capture.
3. MLAxisCfgFastIn(PipeNetwork.AXIS1, MLFI_FIRST, MLFI_RISING_EDGE)
 - This function call is necessary at least one time, even if the Trigger pipe block is configured properly
4. MLTrigIsTriggered(PipeNetwork.TRIGGER1)
 - This function returns TRUE if the Fast Input associated to the Trigger pipe block given as argument has been triggered
5. MLTrigReadPos(PipeNetwork.TRIGGER1)
 - This function returns the position of the Pipe Network at the time that the Fast Input associated with the Trigger pipe block was issued

NOTE

You have to correct the position by taking into account the delay due to the number of cycles needed to read the timestamp of the Fast Input. You can use MLTrigWriteDelay to address this issue.

6. MLTrigReadTime(PipeNetwork.TRIGGER1)
 - This function returns the time associated with the Fast Input as explained in "Interpret a Timestamp" (→ p. 553).
Note that this function is of lesser importance compared to the previous one.
7. MLTrigClearFlag(PipeNetwork.TRIGGER1)
 - This function rearms the Trigger pipe block
8. MLAxisRstFastIn(PipeNetwork.AXIS1, MLFI_FIRST)
 - This function rearms the Axis pipe block

After the Trigger block pipe position is determined and calculations are made in the Registration program, a corrective move is typically done using a [Cam](#) Pipe Network block for precision motion control.

10.7.11 Practical Applications - Camming

These topics provide procedures to use when programming camming.

10.7.11.1 Cam On The Fly

In addition to creating and modifying a Cam Profile using the IDE, an application programmer can also create or modify a new Cam Profile directly from their application. This allows new Cam Profiles to be defined while the application is still online, without stopping the machine to load a new application. An application programmer might use this feature to modify their application at runtime to adjust their Cam Profiles for varying product shapes and sizes.

This procedure is used to create and build a new Cam Profile on the fly.

1. Before the motion engine is started, reserve memory for the profile that will be created on the fly.
This is done using MLProfileCreate.
2. Define the profile properties and profile data points.
This can be done at any time but must be done prior to calling MLProfileBuild.
3. Build the profile with MLProfileBuild.
This takes a number of cycles and the profile will not be ready until the "Done" flag is set to TRUE.
4. The newly created profile can now be used exactly like a profile built in the IDE; it can be used in any number of camming relationships using any of the Pipe Network and PLCOpen Cam Profile functions/function blocks.

Once you have created a Cam Profile using MLProfileBuild, if you need to modify that Cam Profile you must first release the existing Cam Profile. The following steps will release the Cam Profile.

1. Ensure the profile is not in use (Deactivate the existing profile). In Pipe Network perform a MLCamSwitch on an active Pipe to a different Profile or deactivate the pipe. In PLCOpen, perform an MC_CamOut on the profile or abort a profile move.

2. Call `MLProfileRelease` with the desired `ProfileID` as its input to release the profile so it can be modified.
3. When the "Done" flag is set, the `ProfileID` will be free. Modify the existing profiles data and then rebuild the profile `MLProfileBuild`.

NOTE

If a cam profile is Active, by having called `MC_CamTblSelect` and then `MC_CamIn` in `PLCopen` or `MLCamSwitch` in `PipeNetwork`, it cannot be released. In this situation use a second non-active cam to release, build (or rebuild), then activate.

An application is limited to 256 Cam Profile IDs. If additional profiles are desired, an existing profile can be released with `MLProfileRelease`. This frees its `ProfileID` so it can be used in the construction of a new profile. Releasing a profile is simple, and is performed with the following steps.

1. Ensure that the profile is not in use (Deactivate the existing profile). See for more details.
2. Call `MLProfileRelease` with the desired `ProfileID` as its input to release the profile so it can be modified.
3. When the "Done" flag is set, the `ProfileID` will be free and the old profile can be used for a new profile, calling either `MLProfileInit` or `MLProfileBuild`.

10.7.11.2 Positioning an Axis Before Starting Camming

The function block `MC_CamStartPos` is used to position a slave axis in its starting position for a `MC_CamIn` move with a slave absolute profile.

To position the slave axis for the `MC_CamIn` move, the typical programming sequence is:

1. With the master axis at standstill, call **`MC_CamStartPos`** to determine the start position for the slave axis.
2. Call `MC_MoveAbsolute` to move the slave axis to its start position.
3. Call **`MC_CamIn`** with `StartMode = 0` (Start mode).
The `MC_CamIn` inputs **`MasterOffset`**, **`SlaveOffset`**, **`MasterScaling`**, and **`SlaveScaling`** should have the same values as used in the call to **`MC_CamStartPos`**.

See "CAM Profile Switching" (→ p. 217).

10.7.11.3 Resume Camming After an E-Stop

The `MC_CamResumePos` function block is used to return a slave axis to its profile position after an event (such as an E-stop) caused the slave axis to go off path.

To return a slave axis to its `MC_CamIn` profile position, the typical programming sequence is:

1. With the master axis at standstill, call **`MC_CamResumePos`** to determine the profile position for the slave axis.
2. Call `MC_MoveAbsolute` to move the slave axis to the position calculated by **`MC_CamResumePos`**.
3. Call **`MC_CamIn`** with `StartMode = 1` (Resume mode).

10.7.12 Restarting Motion with Pipe Network

An advantage of the Pipe Network is to minimize machine downtime and reduce material waste when a non-fatal error occurs. After stopping the motion with `MLAxisStop` command, it can be restarting by using the `MLAxisReAlign` function block.

ⓘ IMPORTANT

`MLAxisReAlign` must be called after the `MLAxisStop` command, otherwise all motion commands are ignored

For each axis:

Step	Example Application Code
Check Axis Status	<pre>AxisStatus := MLAxisStatus(PipeNetwork.AXI_A1_Axis); IF AxisStatus.6 THEN StepCounter := 1; END_IF;</pre>
Turn axis back on (re-enable)	<pre>IF MLAxisPower(PipeNetwork.AXI_A1_Axis, PowerUp) THEN StepCounter := 2; END_IF;</pre>
Calculate position difference between the Reference and Actual Positions	<pre>DeltaPos := (MLAxisCmdPos(PipeNetwork.AXI_A1_Axis) - MLAxisReadActPos(PipeNetwork.AXI_A1_Axis));</pre>
Determine how far to move	<pre>IF DeltaPos > LREAL#0.5*DEF_A1_PosPeriod THEN DeltaPos := DeltaPos - DEF_A1_PosPeriod; ELSE IF DeltaPos < LREAL#-0.5*DEF_A1_PosPeriod THEN DeltaPos := DeltaPos + DEF_A1_PosPeriod; END_IF; END_IF; MLAxisReAlign(PipeNetwork.AXI_A1_Axis, 1000.0, 1000.0, 100.0, DeltaPos); StepCounter := 3;</pre>
Wait for move to be completed	<pre>IF MLAxisReAlgnRdy(PipeNetwork.AXI_A1_Axis) THEN StepCounter := 4; END_IF;</pre>

For the machine:

Step	Example Application Code
Execute multi-axis move	<pre>MLMstRun MLMstRun(PipeNetwork.MASTER, 500);</pre>

10.7.13 Superimposed Axes with PLCopen

This feature allows the application program to superimpose the moves of multiple axes ("Superimposed Axes") on top of the move of another axis ("Receiving Axis").

- This is performed internally by adding the command deltas of the Superimposed Axes to the command delta of the Receiving Axis.
- A maximum of four different Superimposed Axes can be superimposed upon a Receiving Axis.

10.7.14 Torque Feed-forward

The torque feed-forward tells the controller what forces is required to move the axis in an arbitrary trajectory.

Here are the major features of torque feed-forward:

- Torque feed-forward results in virtually instantaneous response of the system.
- Feedback control loops (using PID loop or similar) take a finite amount of time before reacting.
- Torque feed-forward relies on an imperfect model of the system. This means that the feed-forwards need help from the feedback control loop in order to get accurate motion.
- Torque feed-forward can make the bulk of the move very quickly, while the feedback control loops correct the small errors that remain. As a result, a faster settling time can be achieved than if torque feed-forward was not used.
- There is a common misconception that torque feed-forward is similar to control loops and result in instability. Torque feed-forward is open loop, so it cannot suffer from closed loop instability.
- Torque feed-forward is typically less sensitive to being misadjusted than closed loop parameters.
- Feedback control systems can be excited into instability by grossly misadjusted torque feed-forward. However, the amount of misadjustment in the torque feed-forward necessary to cause such instability is very rare.

10.7.15 Tuning Controller Performance for EtherCAT Communication Latency

The response time for reading axis demand position data varies between different drive models.

- The response times also vary in reporting back TxPDO data such as actual position and time-based capture values.
- These different response times can lead to different lag in applications which use camming, gearing, and registration features.
- The KAS-IDE has several configuration parameters which allow you to tune your system to work best.

Example: Drive A has a 1 cycle latency for TxPDO data, and Drive B has 2 cycles latency.

The `MC_AXIS_PARAM_VELCOMP_FACTOR` parameter is used to specify 1 (for Drive A), and 2 (for Drive B) cycles.

The features and corresponding parameters are listed below.

TIP

If the drives in an existing system are changed (e.g., during an upgrade from AKD to AKD2G drives), the parameters need to be retuned to maintain optimal performance.

Feature	Parameters	Read Me For More Information
PLCopen Camming PLCopen Gearing	Axis parameters: <ul style="list-style-type: none"> • <code>MC_AXIS_PARAM_VELCOMP_FACTOR</code> • <code>MC_AXIS_PARAM_VELCOMP_FILTER</code> 	<ul style="list-style-type: none"> • "Axis Parameters" (→ p. 749) • "Velocity Compensation" (→ p. 776)
PLCopen TouchProbe PLCopen Registration	Axis parameter: <code>MC_AXIS_PARAM_SENSOR_DELAY</code>	<ul style="list-style-type: none"> • MC TouchProbe and Time-Based Capture (KDN Article) • "PLCopen Registration" (→ p. 566)
Pipe Network External Feedback	Use a Phaser block to compensate for the delay	Motion Library - Phaser
Pipe Network Trigger Block	Trigger Delay	<ul style="list-style-type: none"> • <code>MLTrigReadDelay</code> • <code>MLTrigWriteDelay</code>

NOTE

The AKD drive supports an object to configure the EtherCAT input data for immediate or 1 cycle delay (default for backwards compatibility).

10.8 Motion Bus and Fieldbuses

Depending on the fieldbus used in your project (i.e., EtherCAT, PROFINET, etc.), you must make use of the configuration tools.

The controller can be connected to multiple Ethernet devices simultaneously by connecting a switch to the top of the controller:

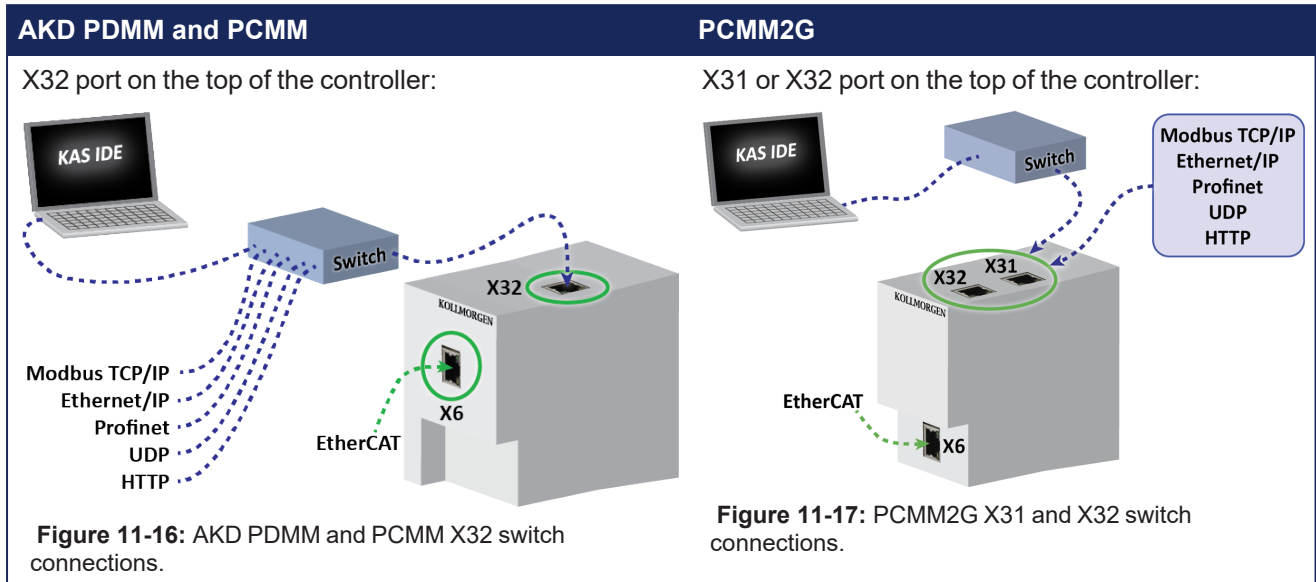

TIP

See the "Controller Performance Guidelines" (→ p. 622) for information on how the CPU load is affected when transmitting and receiving data between network devices and PLC variables.

10.8.1 EtherCAT

- For configuration, see [click here](#)....
- For I/O mapping, see [click here](#)....
- For error management, see [click here](#)....
- For EtherCAT XML Device Description, see the [Beckhoff](#) website.

10.8.2 EtherNet/IP

The KAS Runtime includes a fully integrated EtherNet/IP Adapter driver and Scanner driver for exchanging data with EtherNet/IP tag-based devices such as PLCs.

- EtherNet/IP Adapter (server), Scanner (client), Tag Client, and FlexIO/Point IO configurations are supported.
 - Use drag and drop for mapping PLC variables to PROFINET.
- Setting up "EtherNet/IP IO Scanner (Client)" (→ p. 589).
- Setting up "EtherNet/IP Adapter (Server)" (→ p. 587).
- Setting up "EtherNet/IP Tag Client" (→ p. 592).

10.8.3 Modbus and TCP/IP

- Setting up "Modbus Slave" (→ p. 594).

10.8.4 PROFINET

This fieldbus is PROFIBUS over Ethernet.

We define one controller and have one or more devices.

Configuration

- For configuring the controller, see "Configure a PROFINET IO Controller" (→ p. 597).
- For configuring devices, see "Configure a PROFINET IO Device" (→ p. 602).

10.8.5 I/O Mapping (for Profibus Fieldbus)

This procedure describes how to map inputs and outputs to PLC variables on the Profibus fieldbus.

The mapping can be done from the Dictionary, but also with the "Custom Input/Output Editor" (→ p. 457).

NOTE

See (→ # 314, Map Input and Output to Variables) for more information about remote IOs on EtherCAT Motion Bus.

To map a variable from the Dictionary to a physical input or output:

1. Open the Variable list editor available in the [Dictionary](#) toolbox.
2. Right-click on the variable to be mapped.
3. Select the **Variable I/O Mapping** command in the menu to open the mapping dialog.

By default the setting is NONE which means that the variable is a standard variable.

4. Select I/O (instead of NONE) and the I/O configuration panel appears:

This form is used to configure the different types of I/Os supported by KAS by defining these parameters:

Field	Description
Type	Defines the I/O type of fieldbus: CIFDriver for Profibus.
Direction	Specifies if the variable is an Output or an Input.
BitSize	Defines the length of the frame to be mapped. See "Data Types" (→ p. 702) for information about length.
Deviceld	Defines the address of the I/O communication card located on to the target device (i.e., PAC).
Slaveld	Defines the address of the I/O node on the fieldbus ring (also see "Communication and Fieldbus" on page 66) For EtherCAT, a fixed address is assigned to each slave node that follows the following convention: <ul style="list-style-type: none"> • first slave item on the network has address 1001 • second slave item has address 1002, and so on...
Moduleld	For the current variable, defines the address identifier (id) in the slice
BitOffset	Set to the first bit in the module of the slice which is mapped

To map a variable on Profibus, define these fields:

Field	Definition
I/O type	Enter CIFDriver.
Deviceld	Set to 0.
Slaveld	Set to the id of the I/O node.
Moduleld	Set to the id of the slice.
BitOffset	Set to the first bit of the slice which has to be mapped.

NOTE

For some drivers, you can select CUSTOM.

See "Modify Input/Output" (→ p. 457) for more information about the format of the **Description** field.

10.8.6 Add an Unsupported EtherCAT Device

NOTE

This procedure is for **advanced** users only.

When your project contains EtherCAT devices **not** supported by KAS, you must create the configuration using an external tool, and perform these steps:

1. Get the AKD device description ESI file from the official AKD distribution.
2. Verify all the device description ESI files are available for the external tool.
3. Use the external tool and do all the configuration, including these points:
 - a. Set the Cycle Time.
 - b. Turn on the distributed clocks option for all slave drives in order to share a global system time through EtherCAT.
 - c. Assign PDO to each drive (inputs and outputs).
 - d. Set the mode of operation of the drives into **position** mode.
 - e. Insert variable names and do the mapping (see "Map PLC Variables" (→ p. 582)).
4. Use the external tool to export the ENI description file.
5. In KAS, import the ENI file describing all the EtherCAT devices included in the project.
See "ENI File tab" (→ p. 329).

ⓘ IMPORTANT

Importing an external ENI file overrides all EtherCAT project device information and configuration settings in the KAS-IDE.

These views and configurations are **not** applicable when using an imported ENI file:

- Project View: All devices located under the EtherCAT node.
- EtherCAT Device View tabs:
 - General Properties
 - PDO Selection/Mapping
 - Distributed Clock
 - CoE Init-Commands
- Slice I/O Properties
- Mapping PLC Variables to Slice I/O or PDO objects.

Information displayed in the views may not match the imported ENI file.

10.8.6.1 Modify the EtherCAT Image in Cyclic Mode

In the application program, when integrating non-standard EtherCAT devices, use these function blocks to update the EtherCAT frame.

- ECATReadData
- ECATWriteData

See "EtherCAT Motion Bus Concepts" (→ p. 786).

10.8.6.2 Configure the EtherCAT Device

Use these Functions Blocks:

- ECATReadSdo
- ECATReadSdoData
- ECATWriteSdo
- ECATWriteSdoData

10.8.6.3 Map PLC Variables

When you use an XML network description file generated with an external configurator, you need to add special tags to the PDO names to ensure the PLC variables can be mapped to IO channels.

The tags must comply with this convention:

```
@Scope.VariableName+StartBit-Size
```

Field	Description
@	Prefix with character @ the PLC variable names of each of the image attributes that must be mapped.
Scope	Scope can be: <ul style="list-style-type: none"> (Global) ("Retain Variables" (→ p. 707)) <ul style="list-style-type: none"> Parentheses must surround the scope when it is Global or Retain. Program Name <ul style="list-style-type: none"> Even for the case of nested child SFC programs, the variables still belong to a unique, well-defined subprogram.
+StartBit	Optional: Integer that defines the bit from which the data must be written or read from the PLC variable.
-Size	Optional: Integer that defines the number of consecutive bits in the image which must be copied to/from the PLC variable. When present, this setting has precedence over the <BitSize> tag of the XML file.

10.8.6.3.1 Examples

```
(Global).MachineState
(Global).bLedStatus:0-1
(Global).bLedStatus:1-1
(Global).myINT:+4
main.variable:3+4-8
```

NOTE

This convention is applicable for simple variables.
KAS does not yet support mapping for **Structs and Arrays**.

10.8.7 Set Up FSoE Master and an AKD2G with SafeMotion Monitor

This topic describes how to:

- Manually set up FSoE PDOs
- Copy links for a FSoE Master and an AKD2G with SafeMotion Monitor.

This example uses a simple EtherCAT topology consisting of a Controller (PxMM or PCMM2G), a BBH SCU safety master (**Device_1**), and an AKD2G with SMM Basic safety drive (**AKD2G_1**).

TIP

If using a BBH SCU-1-EC and SafePLC2 software, then the FSoE PDOs can be automatically setup by the KAS-IDE and SafePLC2.
See "SafePLC2 Projects" (→ p. 189) for more information.
For all other third party FSoE Masters, use this procedure.

10.8.7.1 Create Safety Application

First, use the 3rd party Safety PLC software to create a safety application for the FSoE master. For example, the application will contain a FSoE master and an AKD2G with Axis1 and Axis2 as slave devices.

1. Set the AKD2G Connection IDs to match the the AKD2G SafeIDs.
2. Compile and download the safety application to the FSoE Master.
3. Run the safety application in FSoE Master.

The state will be "Run Intern" and the FSoE state will be "8".

10.8.7.2 KAS-IDE Project Set Up

To finish the example, a project is created in the KAS-IDE using the 2-axis Pipe Network template.

1. The IP address of the controller is set in the project.
2. Scan the EtherCAT network to discover the devices.

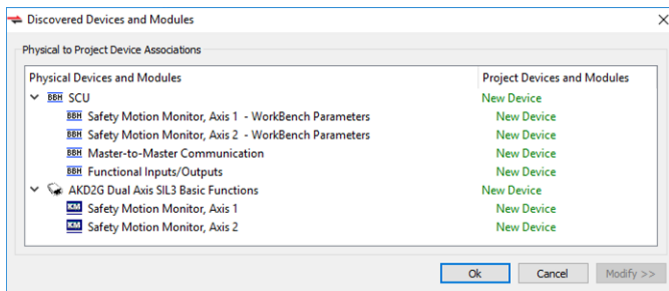

3. We are prompted to recompile the project due to changes in the EtherCAT topology. We respond No because we have not set up the PDO copy links.
4. To connect the PDOs we open the "FSoE / PDO Connections tab" (→ p. 331) which is populated with Input and Output PDOs.

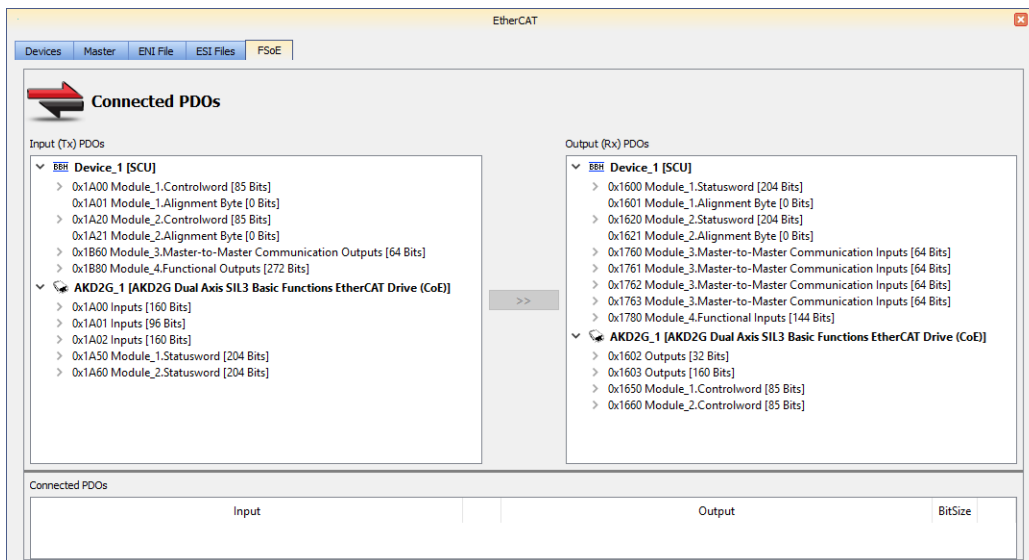

5. To connect PDOs we choose an input, an output, and click the **Connect** button. Connections are displayed at the bottom of the tab.

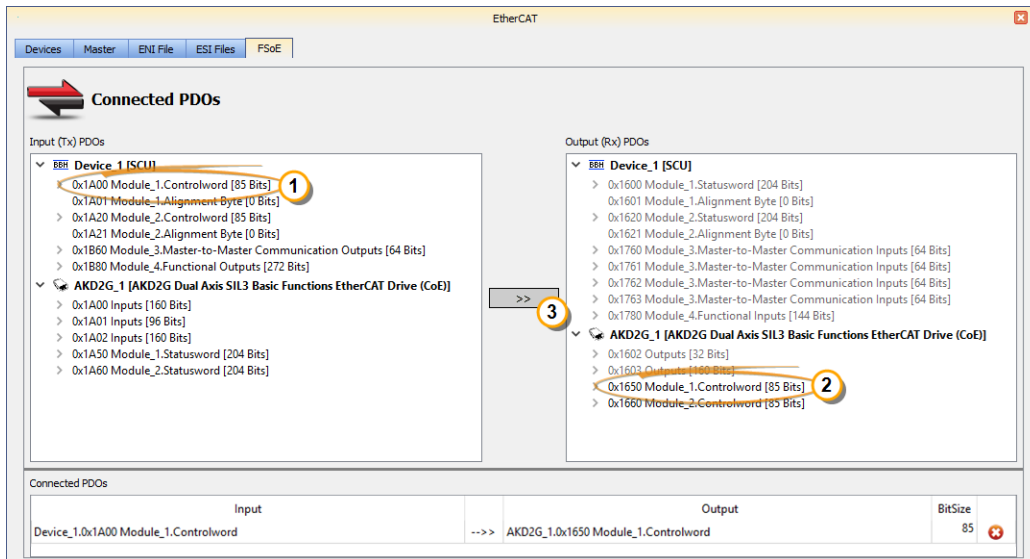

6. We make these connections:

- Device_1[SCU] PDO 0x1A00 to AKD2G_1 PDO 0x1650
- Device_1 [SCU] PDO 0x1A20 to AKD2G_1 PDO 0x1660
- AKD2G_1 PDO 0x1A50 to Device_1 [SCU] PDO 0x1600
- AKD2G_1 PDO 0x1A60 to Device_1 [SCU] PDO 0x1620

7. Compile, download, and run the KAS application.

The BBH master has changed the state to Run and the FSoE state is 4.

The Safety Master and the Safety Slave are now exchanging data over EtherCAT.

See Also

- "AKD2G Safety Parametrization Using FSoE with SCU-1-EC and PxMM / PCMM2G" (→ p. 584)
- FSoEParamsInit
- "Troubleshooting FSoE Safety Parameters" (→ p. 851)

10.8.8 AKD2G Safety Parametrization Using FSoE with SCU-1-EC and PxMM / PCMM2G

The safety features in the AKD2G safety drive (Basic and Advanced) can be activated through either Fail Safe over EtherCAT (FSoE) or digital input or both.

The source of activation is configured inside the safety parameters and it needs to match the system requirements.

This topic describes how to configure and enable safety functions through BBH’s SafePLC and KAS-IDE applications.

10.8.8.1 Requirements

Hardware	<ul style="list-style-type: none"> • SCU-1-EC ("BBH FSoE Master" (→ p. 685)). • Kollmorgen controller (AKD PDMM, PCMM, or PCMM2G). • AKD2G safety drive.
Software	<ul style="list-style-type: none"> • SafePLC2 (BBH Safety Software). • KAS-IDE - v3.05 (or later).

10.8.8.2 Procedure

These steps are for safety parameterization via the direct method using the KAS-IDE and BBH SafePLC2 software.

1. Create a PLCOpen-based project in the KAS-IDE.
2. Scan the EtherCAT network.
3. Configure the safety modules for the AKD2G devices.
 - Choose either the **SRA Parameters** or **SRA Parameters configure via WorkBench** module, based on the application need.
4. When using **SRA Parameters**, add the FSoEParamsInit function block to the project. This function block enables the controller to read the safety parameters from the FSoE Master (SCU-1-EC) and write them to the AKD2G.
5. Follow either of these procedures:
 - If SafePLC2 is installed on the same computer, use "SafePLC2 Projects" (→ p. 189).
 - If SafePLC2 is installed on a different computer than the KAS-IDE, use "SafePLC2 Projects" (→ p. 189).
6. Compile and download the SafePLC application to the BBH safety master (SCU-1-EC) and run the application.
7. Compile the KAS-IDE project.
8. Run the compiled KAS application.
9. Execute the FSoEParamsInit function block when the application is ready and EtherCAT is in OP state.

See Also

- "SafePLC2 Projects" (→ p. 189)
- "Set Up FSoE Master and an AKD2G with SafeMotion Monitor" (→ p. 582)
- FSoEParamsInit
- "Troubleshooting FSoE Safety Parameters" (→ p. 851)

10.8.9 Fieldbus Editor

10.8.9.1 EtherNet/IP Controller Data Communications

This information applies to both the Scanner and Adapter:

- A maximum of four different connections:
 - One Adapter Connection with one O -> T Assembly and one T -> O Assembly.
 - A maximum of three Scanner Connections each with one O -> T Assembly and one T -> O Assembly.
 - Total: A maximum of eight Assemblies (4 O -> T and 4 T -> O).
- Connections can be:
 - All to one product (with unique IP addresses).
 - To a maximum of four products with four unique IP Addresses.
- Each assembly can transfer a maximum of 500 bytes.
- Maximum communications is 8 x 500 = 4000 bytes.
- Assemblies and connections can be mixed in any suitable manner.
 - Examples:
 - Set up the controller to talk to four different Adapters with each one having a O -> T Assembly and T-A Assembly.
 - Set up the controller:
 - As a Scanner (Client) to connect to three different EtherNet/IP Servers (Adapters) each with one O -> T Assembly and one T -> O Assembly.
 - As a Server (Adapter) to connect to a Scanner (Client) with one O -> T Assembly and one T -> O Assembly.

10.8.9.2 EtherNet/IP Controller EDS File

The KAS installation contains an EtherNet/IP EDS file for the Kollmorgen controller.

This file may be needed by other controllers, (e.g., PLCs, PCs, etc.) to configure the EtherNet/IP communication with a controller.

The `KAS_Controller_EIP.eds` file is located in the `\Astrolabe\Bin\EDS` directory, where the KAS software was installed.

By default, the EDS file is located here:

```
C:\Program Files (x86)\Kollmorgen\Kollmorgen Automation Suite\Astrolabe\Bin\EDS\KAS_Controller_EIP.eds
```

Revision	Compatibility	Change
1.0	KAS v2.7 only	Initial revision.
1.1	KAS v2.8 only	Updated vendor information.
1.2	KAS v2.9 only	Support a maximum of four input and output assemblies when KAS Runtime is configured as adapter (server), up from 1.

10.8.9.2.1 Using EDS Files

An EDS file may be required by a third-party tool when the KAS controller is configured as an EtherNet/IP Adapter.

- KAS adapter input/output images are configurable.
- A configuration matching the adapter must be defined on the scanner side.

NOTE

The data limit is:
 500 bytes of data maximum O(originator)->T(target) and
 500 bytes of data maximum T(target) -> O(originator).
 This is based on the EtherNet/IP specification.

The data block sizes in EDS files are predefined in bytes: 0, 1, 2, 4, 8, 16, 32, 64, 128, 256, 500.

Use the closest existing configuration size that exceeds the needed amount of data.

Example: If 40 bytes is sent O->T and 64 bytes is sent T->O, two 64 byte values must be selected.

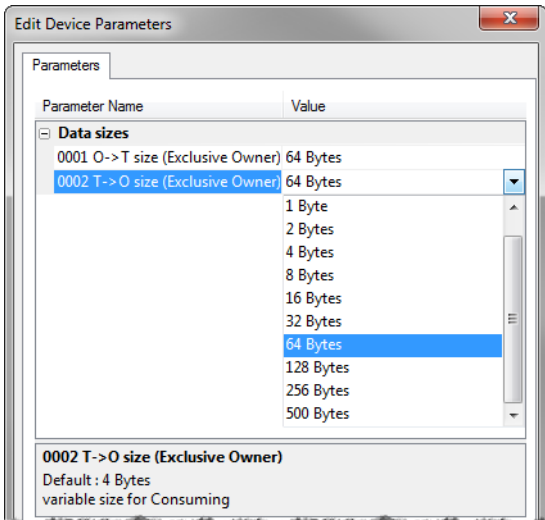

Figure 11-18: Example of setting byte sizes in a third-party Network Configurator.

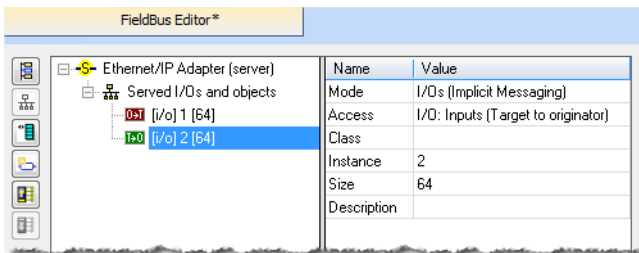



Figure 11-19: Example of setting byte sizes in the KAS-IDE Fieldbus Editor

10.8.9.3 EtherNet/IP Adapter (Server)

The KAS Runtime includes fully integrated EtherNet/IP server driver for exchanging CIP I/O assemblies as an EtherNet/IP adapter in your applications.

10.8.9.3.1 Data Exchange - Configuration

A dedicated configuration tool is integrated in the KAS-IDE.

1. Double-click the Fieldbus node in the project explorer to open it.
2. Click the **Insert Configuration** icon  to add the Fieldbus configuration.
3. Select the **EtherNet/IP Adapter** in the configuration selector.

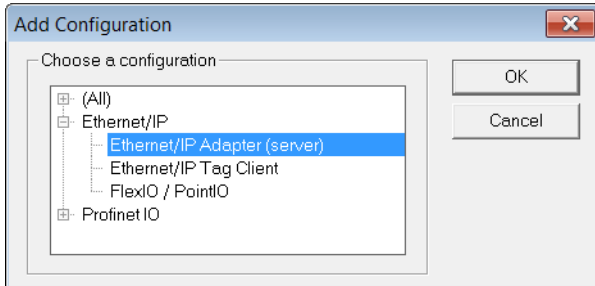

The configuration is represented as a tree:

- EtherNet/IP I/O Scanner
 - Served I/Os and objects
 - I/O Assembly or Vendor Specific Object (*)
 - Exchanged Variable (*)

(*) The items with this mark can appear several times in the configuration.

10.8.9.3.2 Configuration

These items can be configured at the root level:

Identifier	Meaning
Use LAN2	Obsolete
IP Address	IP address of the Ethernet adapter used.

Click the Insert Master icon  to declare a server (adapter device).

Each server is identified by its IP address and an optional Description text.

Select the **Served I/Os and objects node**, then click the Insert Slave icon  to declare a CIP I/O assembly or a vendor specific object. Up to 4 input and 4 output assemblies are supported by the KAS Runtime, even though it is possible to create more in the KAS-IDE.

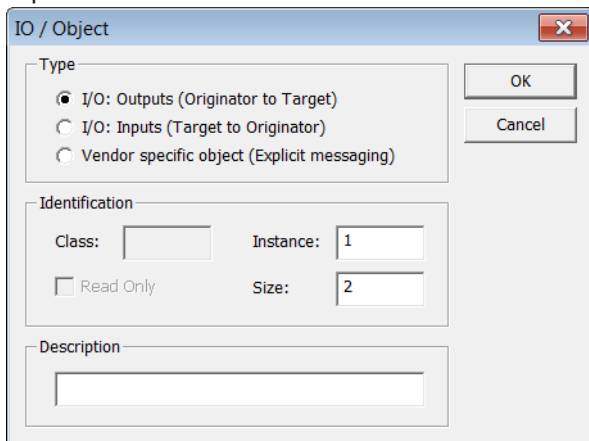

Each assembly is identified by:

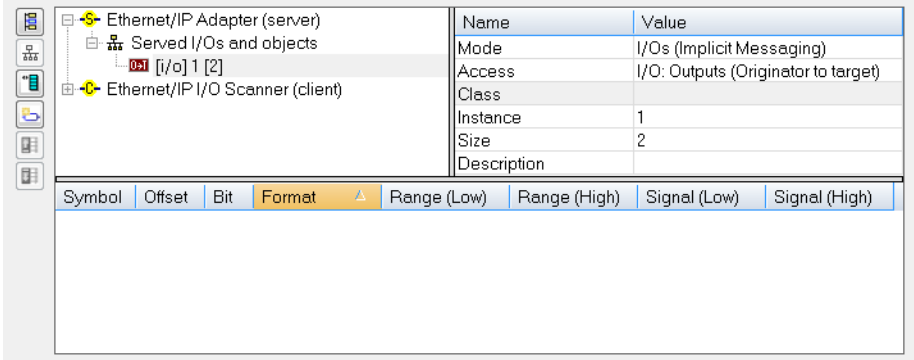
Identifier	Meaning
Mode	The kind of CIP object. Either: <ul style="list-style-type: none"> • I/O assembly • Vendor specific object
Access	In case of a vendor specific object, this property defines the access rights: <ul style="list-style-type: none"> • Read/Write = free access • Read Only = the client (scanner) cannot write the object data
Class	CIP class in case of a vendor specific object. This field should be ignored in case of an I/O assembly. 
Instance	Instance of the CIP assembly or object.
Size	Data size in bytes.
Read Only	Specify that a vendor-specific object is only readable by clients.
Description	Optional description text.

When defining a vendor specific objects, these attributes are available for scanners:

- 1 (get only) = size of the object data.
- 3 (get/set) = object data.

Then map IEC 61131-3 variables on the data of the assembly, for each variable you must specify:

Identifier	Meaning
Symbol	The name of the IEC 61131-3 variable
Offset	Offset in bytes in the assembly data
Bit	Bit offset in the selected byte if format is "Bit"
Format	Format of the data in the assembly

TIP

Drag a variable from the [Dictionary](#) directly to a slave item.

NOTE

The data limit is:
 500 bytes of data maximum O(originator)->T(target) and
 500 bytes of data maximum T(target) -> O(originator).
 This is based on the EtherNet/IP specification.

10.8.9.4 EtherNet/IP FlexIO / PointIO

Before establishing the connection to the POINT IO, these modules require configuration.

This is done through the WEB interface of the POINT IO bus coupler.

1. Double-click the Fieldbus node in the project explorer to open it.
2. Click the Insert Configuration icon  to add the Fieldbus configuration.
3. Select the **FlexIO/PointIO** driver in the configuration selector.

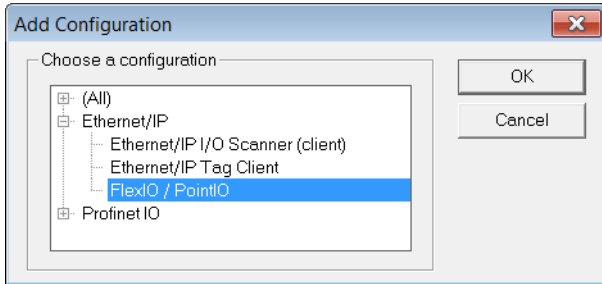

4. Click the Insert Master icon  and select PointIO

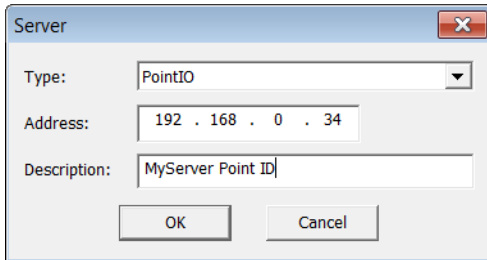

5. Click the Insert Slave icon .
Only modules in the list are supported.
When inserting, the module variables can be declared automatically by checking Declare variables and set a prefix.

NOTE

Modules need to be inserted in the right order.

Configuration is ready and you can download the application to the KAS Runtime.

10.8.9.5 EtherNet/IP IO Scanner (Client)

The KAS Runtime includes a fully integrated EtherNet/IP client driver for exchanging CIP I/O assemblies as an EtherNet/IP scanner in your applications.

10.8.9.5.1 Data Exchange Configuration

A dedicated configuration tool is integrated in the KAS-IDE.

1. Double-click the **Fieldbus** node in the project explorer to open it.
2. Click the **Insert Configuration** icon  to add the Fieldbus configuration.
3. Then select the **EtherNet/IP I/O Scanner** in the configuration selector.

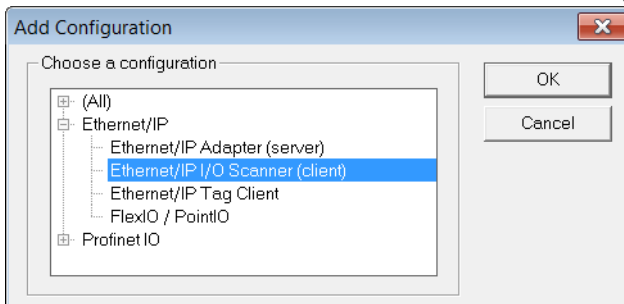

The configuration is represented as a tree:

- EtherNet/IP I/O Scanner
 - Server (an EtherNet/IP adapter device) (*)
 - I/O Assembly (Originator to Target)
 - Exchanged Variable (*)
 - I/O Assembly (Target to Originator)
 - Exchanged Variable (*)

(*) The items with this mark can appear several times in the configuration.

In addition to the IO configuration, explicit messaging can be performed using the blocks eipReadAttr and eipWriteAttr.

10.8.9.5.2 Server Configuration

Click the Insert Master icon  to declare a server (slave adapter).

Each server is identified by its IP address and an optional Description text.

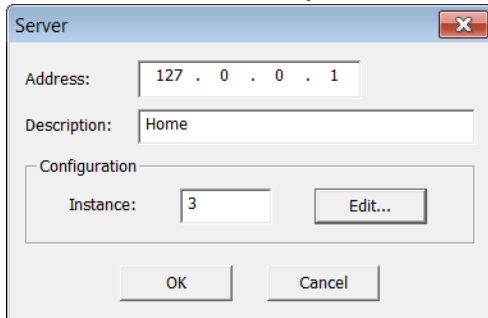

These blocks of data are exchanged with the server for each connection:

- Outputs (originator to target)
- Inputs (target to originator)
- Configuration: a static block sent to the server at connection time.

The instance number for the configuration may be specified in the properties of the server.

10.8.9.5.3 Edit the Configuration Data Block

While most devices do not expect any configuration it may happen that some data is required. For this, double click the server in the tree and click the **Edit...** button in the dialog box.

- The configuration is entered as a list of items.
 - Use the **Type** button to specify the number of items and their data types.
- Structured data types defined in the KAS-IDE are supported.
 - Enter values in the grid.
- If you exchange multiple byte integers (e.g., WORD), you must specify whether the device expects little or big endian formatting.

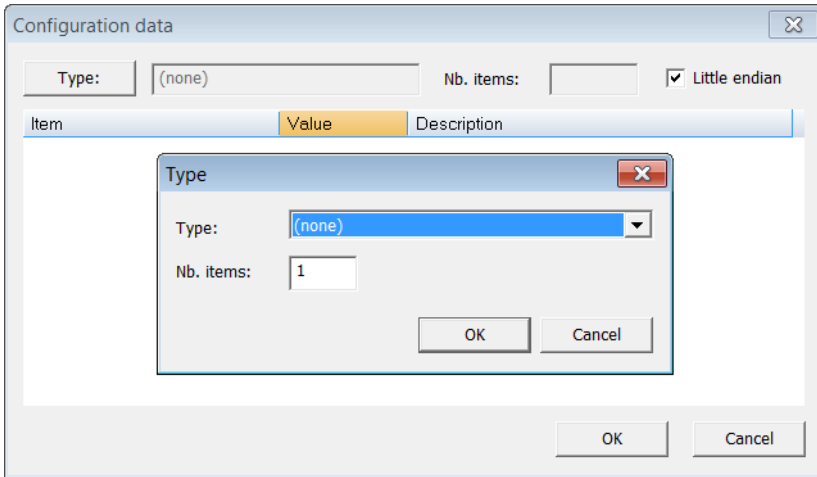

10.8.9.5.4 Assembly Configuration

Click the **Insert Slave** button (🔧) to declare a CIP I/O assembly.

Each assembly is identified by:

Identifier	Meaning
Type	Direction of the I/O assembly. Either: <ul style="list-style-type: none"> • Originator to Target (outputs). • Target to Originator (inputs).
Instance	Instance of the CIP assembly.
Config.instance	The instance number of the configuration assembly. The default value is 100.
Size	Data size in bytes.
Connection type	Type of the CIP connection. Can be Point To Point or MultiCast.
Priority	CIP priority: <ul style="list-style-type: none"> • Low • High • Scheduled • Urgent
32-bit header	Check this option if a 32-bit header is to be sent on notifications.
RPI(ms)	Minimum period for notification of changes in milliseconds. The range is 10 - 10000 ms.
Description	Optional description text.

10.8.9.5.5 Configuring Variables

IEC 61131-3 variables may be mapped on the data of the assembly.

Each variable must have these specifications:

Identifier	Meaning
Symbol	The name of the IEC 61131-3 variable.
Offset	Offset in bytes in the assembly data.
Bit	Bit offset in the selected byte if format is Bit.
Format	Format of the data in the assembly
Mode	Kind of data exchanged through the variable: <ul style="list-style-type: none"> • Data Exchange: A type of input or output data in the assembly. • Server OK: Indicates the status of the IP connection to the server. • I/O connection OK: Indicates the status of the CIP I/O connection. • Last UCMM error: CIP code fo the last error occurred during a connection.

NOTE

The data limit is:

500 bytes of data maximum O(originator)->T(target) and

500 bytes of data maximum T(target) -> O(originator).

This is based on the EtherNet/IP specification.

10.8.9.6 EtherNet/IP Tag Client

The KAS Runtime includes fully integrated EtherNet/IP client driver for exchanging tags with EtherNet/IP tag based devices such as PLCs.

10.8.9.6.1 Data exchange - Configuration

A dedicated configuration tool is integrated in the KAS-IDE.

1. Double-click the Fieldbus node in the project explorer to open it.
2. Click the **Insert Configuration** icon  to add the Fieldbus configuration.
3. Select the **EtherNet/IP Tag Client** in the configuration selector.

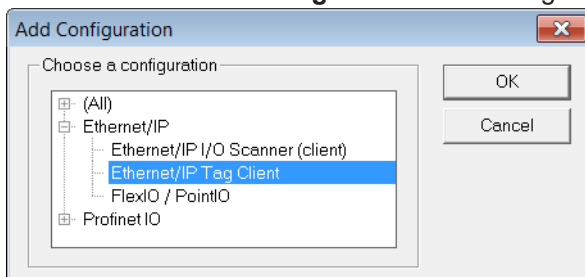

The configuration is represented as a tree:

- EtherNet/IP Tag Client
 - Server (an EtherNet/IP adapter device) (*)
 - Tag (generally an array) (*)
 - Exchanged variable (*)

(*) The items with this mark can appear several times in the configuration.

Driver and configurator are optimized for exchanging arrays (tags declared as arrays in the PLC). However it is also possible to exchange single tags.

10.8.9.6.2 Configuration

Click the Insert Master icon  to declare an server (slave device). Each server is identified by its IP address and an optional description text.

Then you need to configure tags such as declared in the PLC:

- The easiest way is to right-click on the server in the tree and select the **Add ARRAY Tag** command in the contextual menu. Then you enter the properties of the tag request and the symbol of the corresponding array to be used in your IEC 61131-3 application. Configuration of the tag and mapping of all array items is performed automatically.
- Alternatively, click the Insert Slaver icon  to declare the tag and map some variables later on.

A tag request is identified by:

Identifier	Meaning
Tag name	The name of the tag such as declared in the PLC.
PLC Slot	PLC slot number.
Mode	Read or Write. The same tag can be configured twice for both reading and writing.
Nb Elements	Number of array items to read or write.
Offset	O-based index of the first item to read or write in the array.
Tag data type	Data type of the tag such as declared in the PLC. Available Types are: <ul style="list-style-type: none"> • BOOL <ul style="list-style-type: none"> • Single Boolean variable on 1 byte - 00=FALSE / FF=TRUE. • DINT (32-bit signed integer) • DWORD (32-bit string) • DWORD <ul style="list-style-type: none"> • Should be selected if the tag is declared in the PLC as an array of bits. • INT (16-bit signed integer) • SINT (8-bit signed integer)
Period(ms)	Specify in this parameter a period for continuously sending the request. Enter 0 (zero) for a request sent on-demand.
Timeout	Request timeout in milliseconds.

IEC 61131-3 variables are mapped on the data of the tag.

For each variable you must specify:

Identifier	Meaning
Symbol	The name of the IEC 61131-3 variable.
Offset	Offset in bytes in the assembly data.
Bit	Bit offset in the selected byte if format is Bit.
Format	Format of the data in the assembly.
Mode	The kind of data exchanged through the variable: <ul style="list-style-type: none"> • Data Exchange: A piece of input or output data in the assembly. • Server OK: Indicates the status of the IP connection to the server. • Send Request Now: Used as a command for activating the request. • [transaction counter]: Increased each time the request is sent. • [general status]: CIP error code (0 = OK). • [extended status]: CIP extended error code (0 = OK).

The tag is read or written:

- Periodically if a non zero period is specified in the tag configuration.
- When a variable configured as **Send Request Now** becomes TRUE.

In the case of a command variable, the variable is automatically reset to FALSE when the request is sent.

NOTE

The data limit is:
 500 bytes of data maximum O(originator)->T(target) and
 500 bytes of data maximum T(target) -> O(originator).
 This is based on the EtherNet/IP specification.

10.8.9.7 Modbus Slave

- "Protocol Specification" (→ p. 594)
- "Data Exchange Configuration" (→ p. 595)
- "Modbus Slave Configuration" (→ p. 595)
- "Data Types" (→ p. 597)

The KAS Runtime includes fully integrated slave functions for enabling Modbus communication on a serial link or Ethernet.

This communication is done in the background, asynchronously, at the cycle time (20-1000 milliseconds) specified in the Controller Properties. See "Configure the Controller" (→ p. 135) for more information.

- Variables defined in the HMI to describe the interface are passed to the controller this way.
 - See "Map Variables to HMI" (→ p. 186) for more information.
- This means there is no data coherency in the data exchange because the variables read by the Modbus do not come from the same PLC cycle.
- This data has a rather low priority.
 - It is interpreted by human feedback and should never be noticed by the user.

NOTE

Kollmorgen HMIs are limited to communicating no more frequently than every 100 milliseconds.

TIP

It is possible to have two Modbus master devices communicating with a controller at the same time, accessing the same variables.
 Example: Having two separate HMI panels running the same program on a single, large machine.

10.8.9.7.1 Protocol Specification

The protocol supported is Open Modbus on Ethernet.

These are the supported Modbus function codes:

Code	Description
1	Read coils.
2	Read bit inputs.
3	Read holding registers.
4	Read input registers.
5	Write 1 coil.
6	Write 1 register.
15	Write n coils.
16	Write n registers.

- As a default, the first valid address for each kind of data is 1.
- If you use Modbus devices with other addressing conventions, you can change the base offset for each kind of data using the **Tools > Addresses** menu command.

10.8.9.7.2 Data Exchange Configuration

The KAS-IDE has a dedicated configuration tool. To run it,

1. In the **Controller Properties** dialog box, select the **Other Modbus devices** option.
See "Configure the Controller" (→ p. 135) for more information.
2. Double-click the **Fieldbus** node in the project explorer to open it
3. Click the **Insert Configuration** icon to add the Fieldbus configuration.
4. Select the **Modbus Slave** in the configuration selector.
5. Click **OK** to continue.

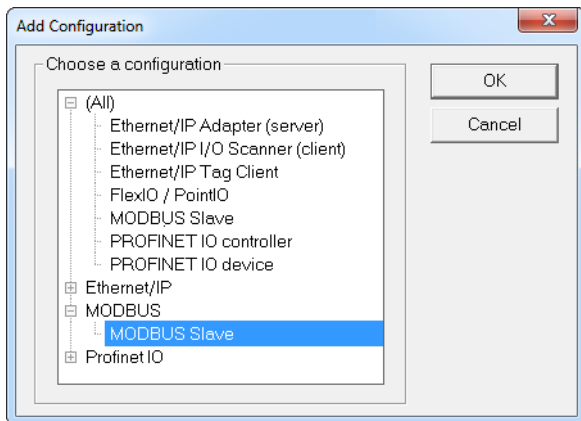

The Modbus Slave configuration is represented as a tree:

- Modbus Slave
 - Slave number (variables that can be accessed from external Modbus masters)
 - Input bits data block (read by masters)
 - Variable (*)
 - Input words data block (read by masters)
 - Variable (*)
 - Coil bits data block (forced by masters)
 - Variable (*)
 - Holding bits data block (forced by masters)
 - Variable (*)

(*) The items with this mark can appear several times in the configuration.

10.8.9.7.3 Modbus Slave Configuration

You need to configure the Modbus Slave to make variables visible from external Modbus masters (e.g., SCADA systems).

This is a simple example of slave configuration:

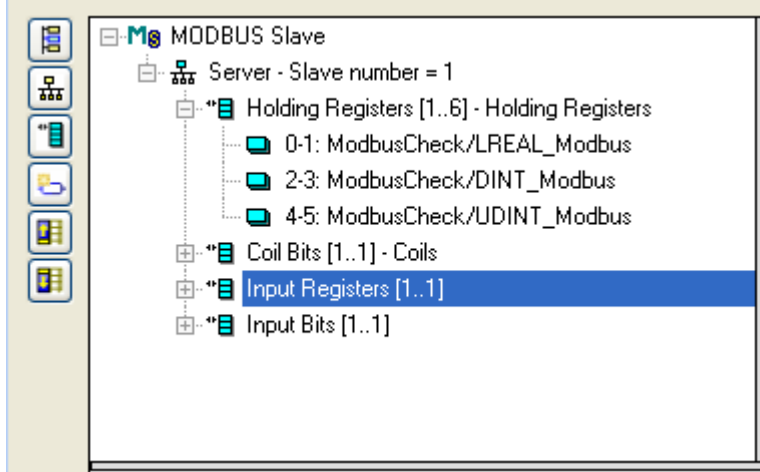

- Double click the **Server** item to setup the Modbus slave number that will identify the runtime application.
- When the local server is selected, use the **Insert Slave/Data Block** menu command to insert Modbus data blocks.
- These kinds of block are available:
 - Coil Bits: bits forced by by external masters (function 5 or 15).
 - Holding Registers: words forced by external masters (function 6 or 16).
 - Input Bits: bits read by external masters (function 2).
 - Input Registers: words read by external masters (function 4).

TIP

For optimal controller performance use Input Registers where possible.

Input Registers require 15-25% less CPU time to exchange data than **Holding Registers** do.

Each data block is identified by a Modbus base address and a number of items (bits or words).

NOTE

Read and write requests sent by Modbus masters are denied if the range specified in the request does not fit within a data block defined in the configuration.

Requests overlapping two data blocks are denied.

Example: If you configure a block of 16 words starting at address 1 and another block of 16 words starting at address 17, a request for read or write of 32 words starting at address 1 is denied and an address error exception is reported.

When a server data block is selected, use the **New symbol** command to map a variable to an item of the data block.

Each variable is identified by a valid symbol of a variable in the open project and an offset in the data block according to Modbus addressing.

Exchanges

- For exchanging:
 - Boolean variables through Modbus words, a hexadecimal mask is available to define to which bit of a word a variable is attached.
 - Example: Enter the mask **0001** to map a Boolean variable to the less significant bit of a word.
 - 32-bit variables (e.g., DINT, REAL, etc.), select to map the variable on two consecutive words.
 - 64-bit variables(e.g., LINT, LREAL, LWORD, ULINT), select to map the variable on four consecutive words

Optional: Sort the variables of each data block according to their offset using the **Sort symbols** menu command at any time.

10.8.9.7.4 Data Types

You can freely map a variable of any data type to a Modbus item.

The Runtime automatically converts the value to the type of the variable.

10.8.9.8 PROFINET Configuration

These topics provide information about PROFINET configuration.

- "Configure a PROFINET IO Controller" (→ p. 597)
- "Configure a PROFINET IO Device" (→ p. 602)
- "PROFINET - Additional Features" (→ p. 607)
- "PROFINET - Data Types" (→ p. 609)
- "PROFINET - Error and Status Codes" (→ p. 609)
- "PROFINET - Resolve Errors" (→ p. 615)

NOTE

Unlike an EtherCAT fieldbus with a dedicated Ethernet interface, the PROFINET fieldbus communicates through the same Ethernet interface as Modbus and other non-fieldbus communication.

There is no prioritization of PROFINET over the other communication protocols.

Frequent HTTP or IDE Oscilloscope communication can cause delay in the PROFINET communications and, ultimately, PROFINET frame loss.

10.8.9.8.1 Configure a PROFINET IO Controller

The IOs of the PROFINET network must be connected to the variables using a PROFINET IO controller.

The KAS-IDE contains a fully integrated configurator for a PROFINET IO RT controller or device.

The PROFINET maximum data size is 1440 bytes Input length and 1440 bytes Output length.

To calculate the size, use the slot configuration view to count the number of bits per slot and convert to bytes.

Example: 7 slots containing 16 outputs of 32-bits each, is $7 \times 16 \times 32 = 3584$ bits = 448 bytes.

ⓘ IMPORTANT

Referring to the PROFINET standard, the units of a PROFINET network are named as IO Controllers (Masters) and IO Devices (Slaves).

🔗 TIP

Install the **CD Prot** driver to use additional features of the PROFINET controller fieldbus editor (e.g., Browse Network for Slaves).

The installer is in `<C:\Program Files (x86)\Kollmorgen\Kollmorgen Automation Suite [version number]\Bin\CDProtDriver>`.

The computer must be rebooted after installing the driver.

NOTE

PROFINET is only supported on AKD PDMM, PCMM, and PCMM2G controllers.

Configuration Procedure

1. Click **Insert > Insert Master/Port** to open the PROFINET IO controller dialog.

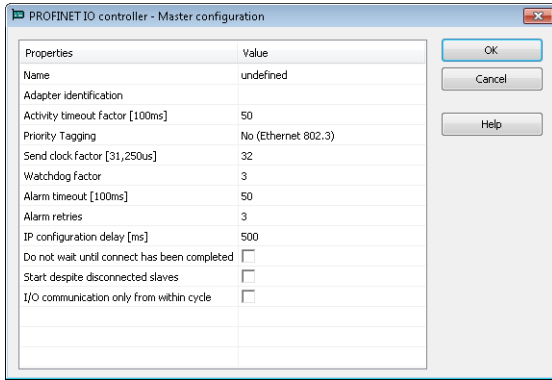

These parameters can be changed:

Parameter	Meaning
Name	<ul style="list-style-type: none"> A device name consists of labels. The labels must follow these conventions: <ul style="list-style-type: none"> 1 or more labels, separated by [.] Total length is 1 to 240. Label length is 1 to 63. Labels consist of [a...z and 0...9]. Labels do not start or end with a hyphen [-]. The first label does not start with port-xyz or port-xyz-abcde with a,b,c,d,e, x, y, z = 0...9. Device names do not have the form n.n.n.n, n = 0...999. Labels only start with xn- if RFC 3490 is applied.
Adapter identification	<ul style="list-style-type: none"> The PROFINET adapter identification for the controllers are: <ul style="list-style-type: none"> AKD PDMM and PCMM: tsec0. PCMM2G: eth1. <p>When the application is compiled, based on the controller type, the PROFINET adapter identification is changed to match the required name.</p>
Activity timeout factor [100ms]	<ul style="list-style-type: none"> Timeout for the connection establishment to the devices. <ul style="list-style-type: none"> Maximum time between beginning of connection establishment and the first cyclic data exchange. Timeout factor based on 100ms.
Priority Tagging	<ul style="list-style-type: none"> Yes: cyclic data exchange without priority tag. No: data exchange with priority tag.
Send clock factor [31,250µs]	<ul style="list-style-type: none"> Send the clock factor. Multiple of 31,250µs (32 = 1ms).
Watchdog factor	<p>Watchdog factor (default 3):</p> <ul style="list-style-type: none"> The watchdog factor defines how many frames may be missing until the device is set back. Watchdog triggers: <ul style="list-style-type: none"> a) frames may be lost (e.g., due to bad cabling). b) frames may arrive delayed due to blocking situations in the network (e.g., due to a non-separated network). The watchdog may be triggered as soon as earlier file transfer occurs between the controller and the IDE when the default value is used. <ul style="list-style-type: none"> Increase this value if you encounter frequent watchdog triggers.
Alarm timeout [100ms]	Alarm timeout (default 50).

Parameter	Meaning
Alarm retries	Number of alarm retries (default 3).
IP configuration delay [ms]	<ul style="list-style-type: none"> IP configuration delay (default 500). Defines the time to wait whether some devices are not ready after start.
Do not wait until connect has been competed	<ul style="list-style-type: none"> Click the Do not wait until connect has been competed checkbox to start the application immediately. Clear the Do not wait until connect has been competed checkbox to start the application after all devices are connected.
Start despite disconnected slaves	<ul style="list-style-type: none"> Click the Start despite disconnected slaves checkbox to start the application despite configured but not found devices. Clear the Start despite disconnected slaves checkbox to start the application if all configured devices were found only.
I/O communication only from within cycle	<ul style="list-style-type: none"> Click the I/O communication only from within cycle checkbox to run IO communication from within the VM-cycle. Clear the I/O communication only from within cycle checkbox to run IO communication outside the VM-cycle.

2. Mark the controller and click **Insert > Insert Slave/Datablock** to add a PROFINET IO device.

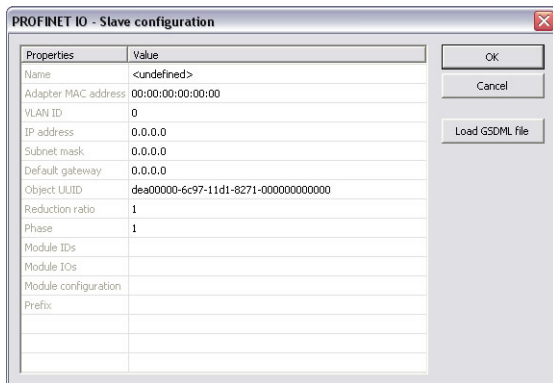

These parameters can be changed:

Parameter	Meaning
Name	<ul style="list-style-type: none"> A device name consists of labels. The labels must follow these conventions: <ul style="list-style-type: none"> 1 or more labels, separated by [.]. Total length is 1 to 240. Label length is 1 to 63. Labels consist of [a...z and 0...9]. Labels do not start or end with a hyphen [-]. The first label does not start with port-xyz or port-xyz-abcde with a,b,c,d,e, x, y, z = 0...9. Device names do not have the form n.n.n.n, n = 0...999. Labels only start with xn- if RFC 3490 is applied.
Adapter MAC address	MAC address of the PROFINET IO device.
VLAN ID	Virtual LAN ID.
IP address	IP address of the device.
Subnet mask	Subnet mask for the IP address of the device.

Parameter	Meaning
Default gateway	Default gateway.
Object UUID	UUID of the device.
Reduction ratio	Reduction ratio (default 16): <ul style="list-style-type: none"> The Reduction ratio defines the frequency for data to be exchanged with the device. The transfer rate is calculated by $\langle \text{Send clock factor} \rangle * 31,250 \mu\text{s} * \langle \text{Reduction ratio} \rangle$. The Send clock factor is a master parameter with a default value of 32. <ul style="list-style-type: none"> All known devices work with this Send clock factor. Example: <ul style="list-style-type: none"> With the default setting of: <ul style="list-style-type: none"> 16, the data transfer rate is 48ms. 2, the data transfer rate is 2ms. Most devices support Reduction ratio settings of 1, 2, 4, 8, 16, 32, etc.
Phase	Phase
Module IDs	Module IDs of the device modules.
Module IOs	Module IOs of the device modules.
Module configuration	Module configuration.
Prefix	Prefix for the variables.

NOTE

With the calculation of $\langle \text{Watchdog factor} \rangle * \langle \text{Reduction ratio} \rangle * \langle \text{Send clock factor} \rangle * 31,250\mu\text{s}$, you get the time that may expire between two frames until the device is set back.
 Example: For the default settings $3 * 32 * 31,250\mu\text{s}$ the connection is set back after 3ms of missing frames. For office networks this time is rather low.
 It is recommended to use a Reduction ratio of 32 and a Watchdog factor of 24 for such networks.
 Example: The connection is reset after $24 * 32 * 31,250\mu\text{s} = 768\text{ms}$.
 If this data exchange rate is too low, separate the PROFINET IO network from the office network (e.g., by a router).

3. Click **Load GSDML file** to import the necessary GSDML file.

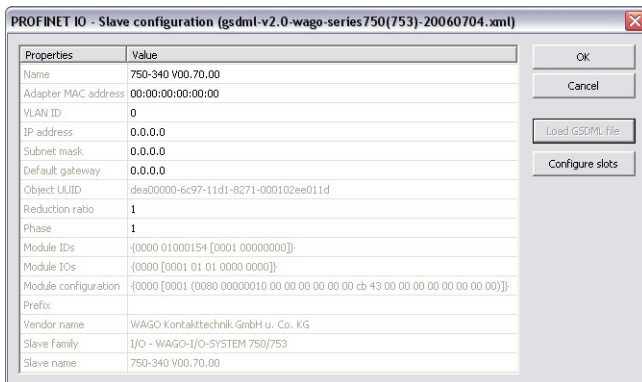

4. Do the slot configuration after the GSDML file import.

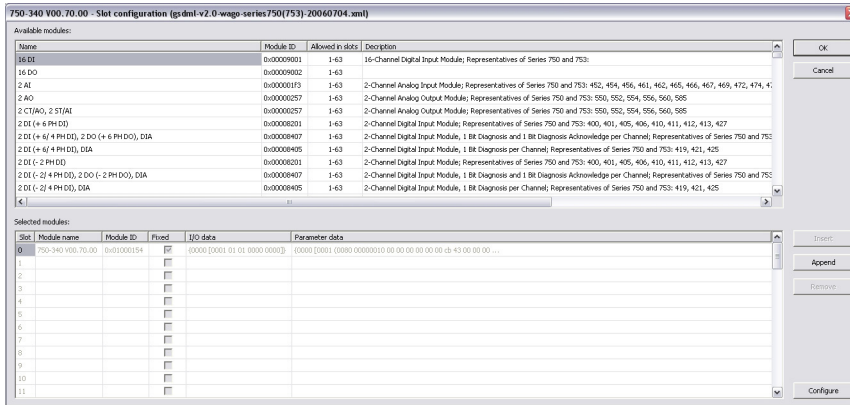

5. Select the modules in the upper list. With the buttons **Insert** and **Append** the modules are copied to the lower list.

You can not configure each module.

Only modules with some sub modules respectively with a sub module with parameter data can be configured.

Mark the according module in the lower list and click the **Configure** button.

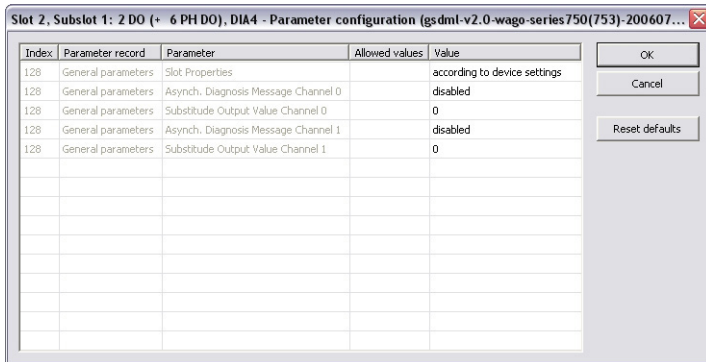
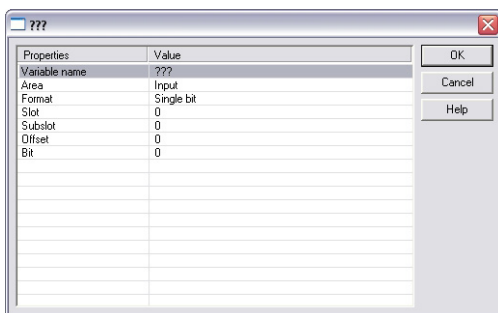

Figure 11-20: Example of configuring sub-modules.

6. Connect the variables with the I/Os. Use **Insert > Insert/Set Variable** to append a variable to a device.



These parameters can be changed:

Parameter	Description
Variable name	Variable name following the IEC 61131-3 syntax.

Parameter	Description
Area	<ul style="list-style-type: none"> Output, Output IOCS, Output IOPS. Input, Input IOCS, Input IOPS. Device status or PNIO status.
Format	<ul style="list-style-type: none"> 32-bit float Signed: <ul style="list-style-type: none"> 8-bit integer 16-bit integer 32-bit integer Single bit Unsigned: <ul style="list-style-type: none"> 8-bit integer 16-bit integer 32-bit integer
Slot	Slot Number.
Subslot	Subslot Number.
Offset	Offset
Bit	Bit

NOTE
 The offset of a variable is relative to a sub module.
 Thus also depending from a slot and subslot.
 The offset of the first variable of a sub module is always 0 (zero).

7. All settings can be changed in the grid too.
 The information refers to the items of the selected item in the configuration tree.

Variable name	Area	Format	Slot	Subslot	Offset	Bit
_0_Slot14_Subslot1_Output0	Output	Signed 16 bit integer	14	1	0	0
_0_Slot15_Subslot1_Output0	Output	Signed 16 bit integer	15	1	0	0
_0_Slot16_Subslot1_Output0	Output	Signed 16 bit integer	16	1	0	0
_0_Slot17_Subslot1_Output0	Output	Signed 16 bit integer	17	1	0	0
_0_Slot18_Subslot1_Output0	Output	Signed 16 bit integer	18	1	0	0
_0_Slot19_Subslot1_Output0	Output	Signed 16 bit integer	19	1	0	0
_0_Slot20_Subslot1_Output0	Output	Signed 16 bit integer	20	1	0	0
_0_Slot2_Subslot1_Output0	Output	Unsigned 8 bit integer	2	1	0	0
_0_Slot3_Subslot1_Input0	Input	Unsigned 8 bit integer	3	1	0	0
_0_Slot4_Subslot1_Input0	Input	Unsigned 8 bit integer	4	1	0	0
_0_Slot5_Subslot1_Input0	Input	Unsigned 8 bit integer	5	1	0	0
_0_Slot6_Subslot1_Input0	Input	Unsigned 8 bit integer	6	1	0	0
_0_Slot7_Subslot1_Input0	Input	Unsigned 8 bit integer	7	1	0	0
_0_Slot8_Subslot1_Input0	Input	Unsigned 8 bit integer	8	1	0	0
_0_Slot8_Subslot1_Output0	Output	Unsigned 8 bit integer	8	1	0	0
_0_Slot1_Subslot1_Input0	Input	Unsigned 16 bit integer	1	1	0	0
_0_Slot14_Subslot1_Output1	Output	Signed 16 bit integer	14	1	2	0
_0_Slot15_Subslot1_Output1	Output	Signed 16 bit integer	15	1	2	0
_0_Slot16_Subslot1_Output1	Output	Signed 16 bit integer	16	1	2	0
_0_Slot17_Subslot1_Output1	Output	Signed 16 bit integer	17	1	2	0

If the GUI Views is online with a target system, the table shows the real-time data of the variables.

10.8.9.8.2 Configure a PROFINET IO Device

The Runtime manages a mapping table containing the PROFINET IO Inputs and Outputs.

The KAS-IDE contains a fully integrated configurator for a PROFINET IO RT controller or device.

The PROFINET maximum data size is 1440 bytes Input length and 1440 bytes Output length.

To calculate the size, use the slot configuration view to count the number of bits per slot and convert to bytes.

Example: 7 slots containing 16 outputs of 32-bits each, is $7 \times 16 \times 32 = 3584$ bits = 448 bytes.

ⓘ IMPORTANT

Referring to the PROFINET standard, the units of a PROFINET network are named as IO Controllers (Masters) and IO Devices (Slaves).

NOTE

PROFINET is only supported on AKD PDMM, PCMM, and PCMM2G controllers.

Configuration Procedure

1. Open the fieldbus configuration window.
2. Right-click in the window and select **Insert > Insert Network**.
The **Add Configuration** dialog opens.

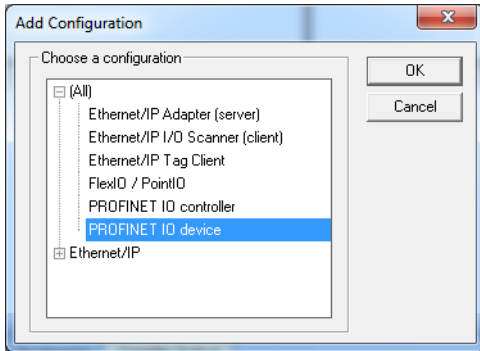

3. Select **PROFINET IO device** and click **OK**.

The configuration is represented as a tree:

- Profinet IO Configuration
 - Profinet IO device (*)
 - Group (*)
 - Variable (*)

(*) These items can appear several times in the configuration (depending on the bus topology).

The I/Os of the PROFINET network must be connected to the variables via a PROFINET IO device.

4. Right-click the PROFINET IO device network and click **Insert Master/Port**.
This starts the declaration of a PROFINET device.
The **PROFINET IO device** dialog opens:

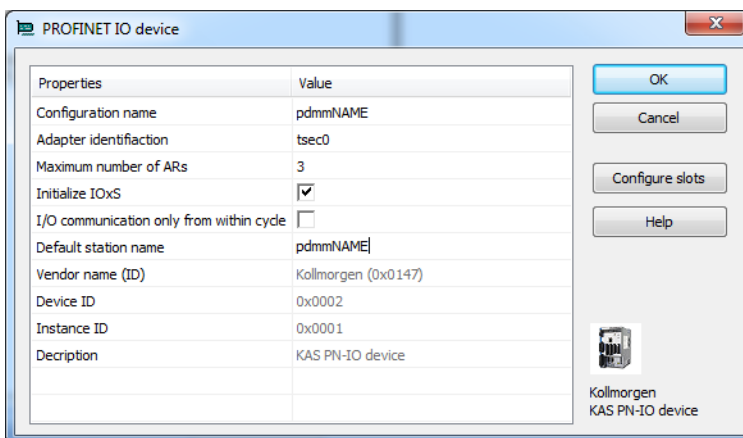

These parameters can be changed:

Parameter	Meaning
Configuration Name	<ul style="list-style-type: none"> A device name consists of labels. The labels must follow these conventions: <ul style="list-style-type: none"> 1 or more labels, separated by [.] Total length is 1 to 240. Label length is 1 to 63. Labels consist of [a...z and 0...9]. Labels do not start or end with a hyphen [-]. The first label does not start with port-xyz or port-xyz-abcde with a,b,c,d,e, x, y, z = 0...9. Device names do not have the form n.n.n.n, n = 0...999. Labels only start with xn- if RFC 3490 is applied.
Adapter identification	<ul style="list-style-type: none"> The PROFINET adapter identification for the controllers are: <ul style="list-style-type: none"> AKD PDMM and PCMM: tsec0. PCMM2G: eth1. <p>When the application is compiled, based on the controller type, the PROFINET adapter identification is changed to match the required name.</p>
Maximum number of ARs	Maximum number of alarm retries (default 3).
Initialize IOxS	<ul style="list-style-type: none"> Click the Initialize IOxS checkbox to initialize IOxS with good status. Clear the Initialize IOxS checkbox to stop initialization of IOxS.
I/O communication only from within cycle	<ul style="list-style-type: none"> Click the I/O communication only from within cycle checkbox to run IO communication from within the VM-cycle. Clear the I/O communication only from within cycle checkbox to run IO communication outside the VM-cycle.
Default station name	Name of the station.

- Click **OK** to save the changes or selections and close the dialog.
- Click the **Configure Slots** button.
The **Slot Configuration** dialog opens.

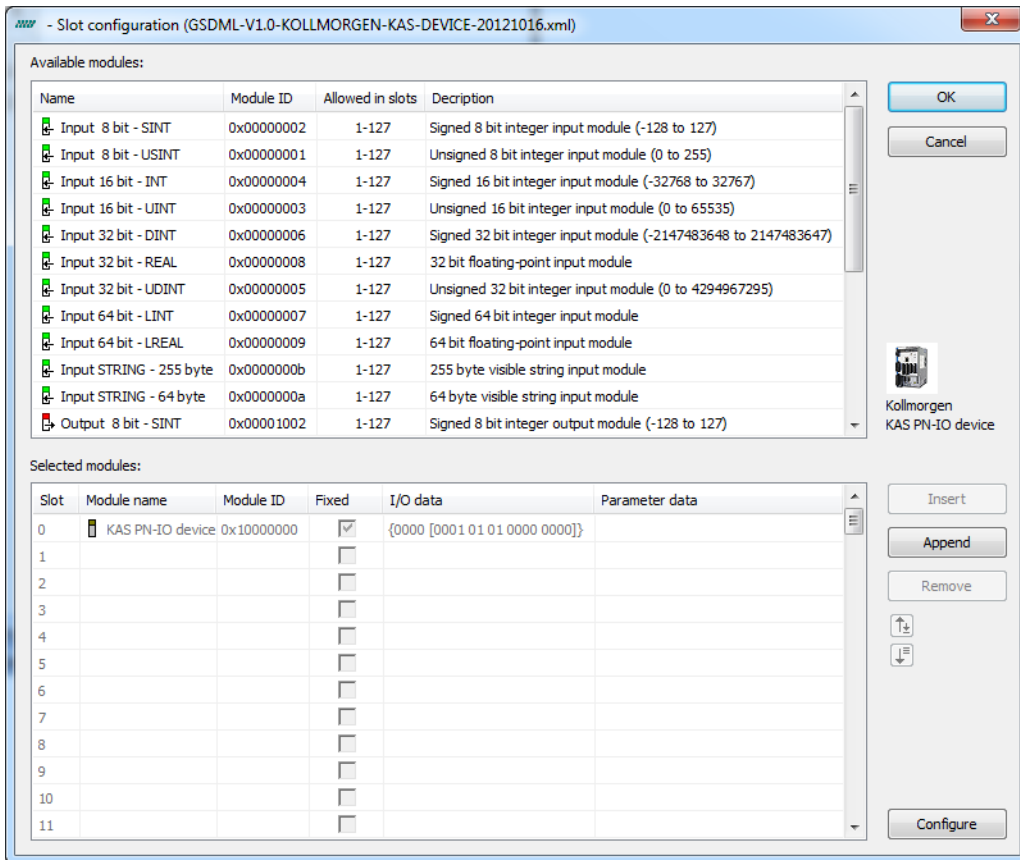

7. Select the modules in the upper list. With the buttons **Insert** and **Append** the modules are copied to the lower list. You can not configure each module. Only modules with some ID sub modules respectively with a sub module with parameter data can be configured. Mark the according module in the lower list and click the **Configure** button.
8. Click **OK** to close the **Slot Configuration** dialog.
9. Click **OK** to close the device window.
10. Click the Insert Variables button.
11. Right click on the master and select Create Variables. This automatically populates the variables and groups.

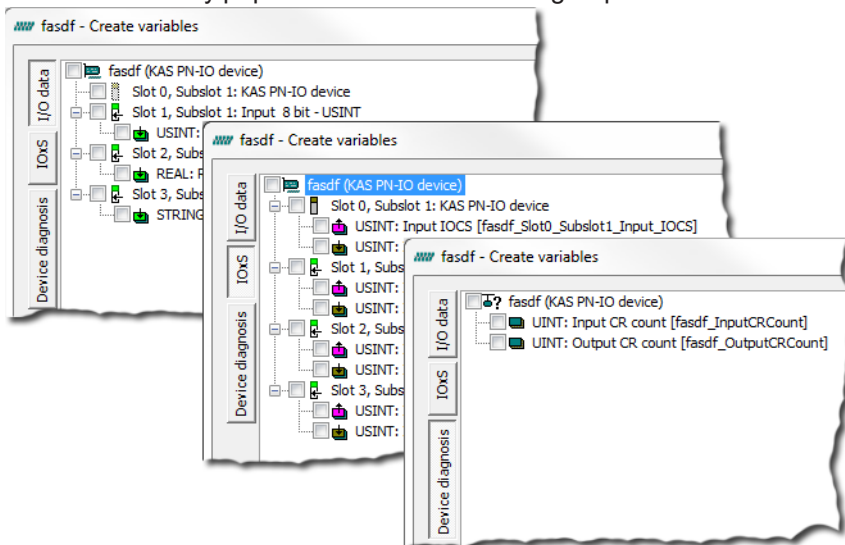

ⓘ IMPORTANT

Every PROFINET variable is expanded to a set of Boolean variables in PLC by default.

Example: A SINT slot is mapped to eight PLC BOOL variables.

If you have many configured slots, many PLC variables are produced.

The controller is slowed by a large amount of PLC variables.

To avoid this, you can right click on a slot in the **Create variables** dialog and select **Pack bits**.

Example: With a SINT slot, this creates one SINT variable in KAS instead of eight BOOL variables.

This helps reduce the number of PLC variables and reduces the load on the controller.

🔖 TIP

The **Pack bits** action may be applied to all slots by right clicking on the root node in the **Create variables** dialog.

- Right-click the device and select **Insert Slave** to add a group.

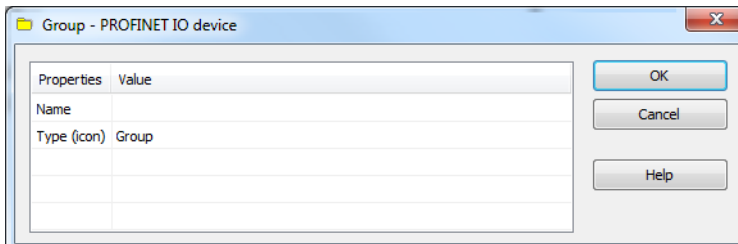

These parameters can be changed:

Parameter	Meaning
Name	Name of the group
Type (icon)	Icon used for the group

- Now you can connect the variables with the I/Os.
Right-click the group and choose **Insert Symbol** to append a variable to a device.

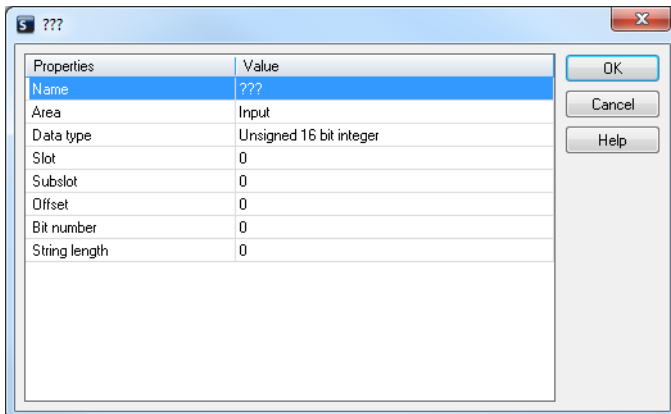

These parameters can be changed:

Parameter	Description
Variable name	Variable name following the IEC 61131-3 syntax.
Area	<ul style="list-style-type: none"> Output, Output IOCS, Output IOPS. Input, Input IOCS, Input IOPS. Device status or PNIO status.

Parameter	Description
Format	<ul style="list-style-type: none"> • 32-bit float • Signed: <ul style="list-style-type: none"> • 8-bit integer • 16-bit integer • 32-bit integer • Single bit • Unsigned: <ul style="list-style-type: none"> • 8-bit integer • 16-bit integer • 32-bit integer
Slot	Slot Number.
Subslot	Subslot Number.
Offset	Offset
Bit	Bit

The offset of a variable is relative to a sub module.

Thus also depending from a slot and subslot.

The offset of the first variable of a sub module is always 0 (zero).

- All settings can be changed in the table.
- The information refers to the items below of the selected item in the configuration tree.

Name	Area	Data type	Slot	Subslot	Offset	Bit number
Broadcom_Slot1_Subslot1_Input0_Bit0	Input	Single bit	1	1	0	0
Broadcom_Slot1_Subslot1_Input0_Bit1	Input	Single bit	1	1	0	1
Broadcom_Slot1_Subslot1_Input0_Bit2	Input	Single bit	1	1	0	2
Broadcom_Slot1_Subslot1_Input0_Bit3	Input	Single bit	1	1	0	3
Broadcom_Slot1_Subslot1_Input0_Bit4	Input	Single bit	1	1	0	4
Broadcom_Slot1_Subslot1_Input0_Bit5	Input	Single bit	1	1	0	5
Broadcom_Slot1_Subslot1_Input0_Bit6	Input	Single bit	1	1	0	6
Broadcom_Slot1_Subslot1_Input0_Bit7	Input	Single bit	1	1	0	7
Broadcom_Slot0_Subslot1_Input_IOCS	Input IOCS	Unsigned 8 bit int...	0	1	0	0
Broadcom_Slot0_Subslot1_Input_IOPS	Input IOPS	Unsigned 8 bit int...	0	1	0	0
Broadcom_Slot1_Subslot1_Input_IOCS	Input IOCS	Unsigned 8 bit int...	1	1	0	0
Broadcom_Slot1_Subslot1_Input_IOPS	Input IOPS	Unsigned 8 bit int...	1	1	0	0

- If KAS is connected to a target system and the system is running, the table shows the real-time data of the variables.

10.8.9.8.3 PROFINET - Additional Features

- "All PROFINET Equipment" (→ p. 607)
 - "Create IOxS for Slave Modules" (→ p. 607)
 - "Create Variables" (→ p. 608)
 - "Device Diagnosis" (→ p. 608)
- "PROFINET Controllers Only" (→ p. 608)
 - "Browse Network for Slaves" (→ p. 608)
 - "Device Configuration" (→ p. 609)
 - "Read Module Configuration" (→ p. 609)
 - "Set Slave Station Name" (→ p. 609)
- "PROFINET - Additional Features" (→ p. 607)
 - "Input Modules or Modules without IO Data" (→ p. 607)
 - "Output Modules" (→ p. 608)

10.8.9.8.4.1 All PROFINET Equipment

10.8.10 Create IOxS for Slave Modules

Based on the defined device modules, the referring IOPS and IOCS variables are generated.

10.8.10.1 Input Modules or Modules without IO Data

- The IOPS state is managed by the device.
 - This is the status sent by the module.
 - If the data is invalid, the external controller that the PxMM is connected to has to ignore it.
- The IOCS state is managed by the external controller.
 - The external controller can indicate if it can't handle the data.

10.8.10.2 Output Modules

- The IOPS state is managed by the external controller, it reflects the status of the data sent by the external controller.
 - If the data is invalid, the device has to ignore it.
- The IOCS state is managed by the device.
 - The device can indicate to the external controller that the data can't be handled.

10.8.11 Create Variables

Find this command in the context menu of the device.

- Based on the defined device modules the referring variables are generated.
- In the same dialog, it is possible to define the variables for:
 - Device diagnosis
 - IOxS

10.8.12 Device Diagnosis

Based on the PROFINET standard, these referring variables can be generated:

- CycleCounter [UINT].
- DataValid [BOOL].
- ProviderState [BOOL].
- StationsProblemIndikator [BOOL].
- Status [BOOL].

10.8.12.0.1.1 PROFINET Controllers Only

TIP

Install the **CD Prot** driver to use additional features of the PROFINET controller fieldbus editor (e.g., Browse Network for Slaves).
 The installer is in <C:\Program Files (x86)\Kollmorgen\Kollmorgen Automation Suite [version number]\Bin\CDProtDriver>.
 The computer must be rebooted after installing the driver.

10.8.13 Browse Network for Slaves

This command is available in the context menu of the network adapter.

All connected PROFINET IO devices are listed.

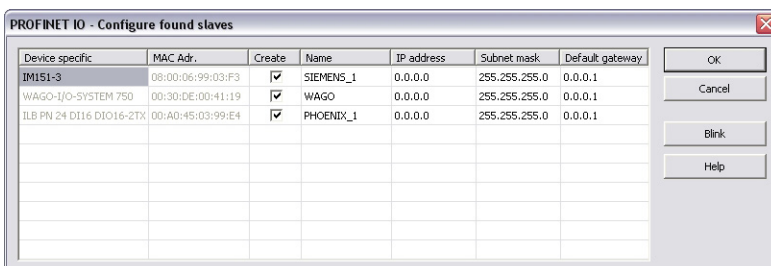

1. In the **Create** column, click the applicable check box to select the devices to add in the tree.
 The Network Link (or another) LED of the marked device blinks for three seconds when the **Blink** button is

clicked.

2. In the **Name** column, set the device name.
 - A device name consists of labels.
 - The labels must follow these conventions:
 - 1 or more labels, separated by [.,].
 - Total length is 1 to 240.
 - Label length is 1 to 63.
 - Labels consist of [a...z and 0...9].
 - Labels do **not** start or end with a hyphen [-].
 - The first label does **not** start with **port-xyz** or **port-xyz-abcde** with a,b,c,d,e, x, y, z = 0...9.
 - Device names do not have the form n.n.n.n, n = 0...999.
 - Labels only start with **xn-** if RFC 3490 is applied.
3. In the IP Address column, define the address of the device.
4. In the **Default gateway** table cell, click the cell to set the gateway automatically.
5. Click **OK** after setting the IP-parameters (address, subnet mask, default gateway).

10.8.14 Device Configuration

After adding the PROFINET devices to the controller, they need to be configured.

1. Double-click the referring device.
2. Load the GSDML file.
If ambiguous module IDs are found, they appear in a window.
3. Choose the right module in the combo-box.

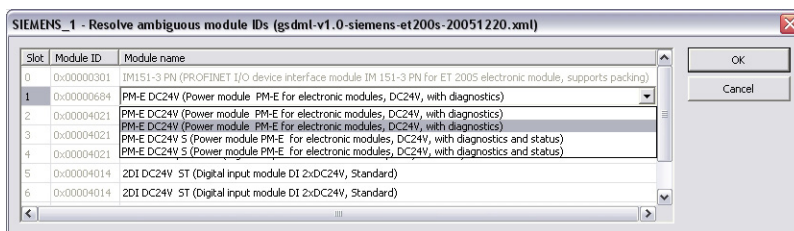

NOTE

Automatic creation of variables can be done primal after this step.

10.8.15 Read Module Configuration

Use this menu command to read out the module configuration.

10.8.16 Set Slave Station Name

Use this menu command to rename the slave names.

10.8.16.0.1 PROFINET - Data Types

Connect variables of any data type to the PROFINET I/Os.

- The Runtime converts the values of the I/Os to the type of the variable.
- STRING variables are not supported.

10.8.16.0.2 PROFINET - Error and Status Codes

The PNIO status is a 32-bit unsigned value.

- It is composed of 4 byte values which define the meaning of the status.
- For positive responses, the PNIO status has a value of 0 (zero).

10.8.16.0.3.1 Error Codes and Meanings

- "PNIO Status Codes - Negative Responses" (→ p. 610)
- "Error Code - Negative Responses" (→ p. 610)
- "Error Decode - Negative Responses" (→ p. 610)
- "Error Code 1 for Error Decode = 80" (→ p. 610)
- "Error Code 1 for Error Decode = 81" (→ p. 611)
- "Error Code 2 for Error Code 1 = 40" (→ p. 612)
- "Error Code 2 for Error Code 1 <> 40" (→ p. 612)
- "Error Code 2 for Error Code 1 = 01" (→ p. 612)
- "Error Code 2 for Error Code 1 = 02" (→ p. 613)
- "Error Code 2 for Error Code 1 = 03" (→ p. 614)
- "Error Code 2 for Error Code 1 = 04" (→ p. 614)
- "Error Code 2 for Error Code 1 = 8" (→ p. 614)
- "Error Code 2 for Error Code 1 = 16" (→ p. 615)

10.8.16.0.4.2 PNIO Status Codes - Negative Responses

Bit	Meaning
0-7	Error Code 2
8-15	Error Code 1
16-23	Error Decode
24-31	Error Code

10.8.16.0.5.3 Error Code - Negative Responses

Error Code	Meaning
DB	Error in connect response
DC	Error in release response
DD	Error in control response
DF	Error in write response

10.8.16.0.6.4 Error Decode - Negative Responses

Error Decode	Meaning
80	Read/Write service
81	Connect, Control, Release service

10.8.16.0.7.5 Error Code 1 for Error Decode = 80

Error Code 1	Meaning
A1	Write error
A2	Module failure
A3-A6	Reserved
A7	Busy
A8	Version conflict
A9	Feature not supported
AA-AF	Device specific
B0	Invalid index

Error Code 1	Meaning
B1	Write length error
B2	Invalid slot/subslot
B3	Type conflict
B4	Invalid area/API
B5	State conflict
B6	Access denied
B7	Invalid range
B8	Invalid parameter
B9	Invalid type
BA	Backup
BB-BF	Device specific
C0	Read constrain conflict
C1	Write constrain conflict
C2	Resource busy
C3	Resource unavailable
C4-C7	Reserved
C8-CF	Device specific

10.8.16.0.8.6 Error Code 1 for Error Decode = 81

Error Code 1	Meaning
01	Connect Parameter Error, Faulty ARBlockReq
02	Connect Parameter Error, Faulty IOCRBlockReq
03	Connect Parameter Error, Faulty ExpectedSubmoduleBlockReq
04	Connect Parameter Error, Faulty AlarmCRBlockReq
05	Connect Parameter Error, Faulty PrmServerBlockReq
06	Connect Parameter Error, Faulty MCRBlockReq
07	Connect Parameter Error, Faulty ARRPCBlockReq
08	Read Write Record Parameter, Error Faulty Record
14	IODControl Parameter Error, Faulty ControlBlockConnect

Error Code 1	Meaning
15	IODControl Parameter Error, Faulty ControlBlockPlug
16	IOXControl Parameter Error , Faulty ControlBlock after a connection establishment
17	IOXControl Parameter Error, Faulty ControlBlock after a plug alarm
28	Release Parameter Error, Faulty ReleaseBlock
40	RMPM (Device state machines, device resources)

10.8.16.0.9.7 Error Code 2 for Error Code 1 = 40

Error Code 2	Meaning
00	ArgsLength invalid
01	Unknown Blocks
02	IOCR Missing
03	Wrong AlarmCRBlock count
04	Out of AR Resources
05	AR UUID unknown
06	State conflict
07	Out of Provider, Consumer, or Alarm Resources
08	Out of Memory
09-FF	Reserved

10.8.16.0.10.8 Error Code 2 for Error Code 1 <> 40

For Error Code 1 <> 40, Error Code 2 refers to a field in the block specified by Error Code 1.

Error Code 2	Meaning
00	Block type
01	Block length
02	Block version (high byte)
03	Block version (low byte)

10.8.16.0.11.9 Error Code 2 for Error Code 1 = 01

Error Code 2	Meaning
04	AR Type

Error Code 2	Meaning
05	AR UUID
06	Session key
07	Initiator MAC address
08	Initiator Object UUID
09	AR Properties
0A	Activity timeout factor
0B	UDP RT port
0C	Station name length
0D	Station name

10.8.16.0.12.10 Error Code 2 for Error Code 1 = 02

Error Code 2	Meaning
04	IOCR Type
05	Reference
06	LT
07	IOCR properties
08	IO data length
09	Frame ID
0A	Send clock factor
0B	Reduction ratio
0C	Phase
0D	Sequence
0E	Frame send offset
0F	Watchdog factor
10	Data hold factor
11	Tag header
12	IOCR multicast MAC address
13	Number of APIs
14	API
15	Number of IO data objects
16	Slot
17	Subslot
18	IO data object offset
19	Number of IOCS
20	Slot
21	Subslot

Error Code 2	Meaning
22	IOCS offset

10.8.16.0.13.11 Error Code 2 for Error Code 1 = 03

Error Code 2	Meaning
04	Number of APIs
05	API
06	Slot
07	Module identification number
08	Module properties
09	Number of sub-modules
0A	Subslot
0B	Sub-module identification number
0C	Sub-module properties
0D	Data description
0E	Data length
0F	IOPS length
10	IOCS length

10.8.16.0.14.12 Error Code 2 for Error Code 1 = 04

Error Code 2	Meaning
04	Type
05	LT
06	AlarmCR Properties
07	RTA timeout factor
08	RTA retries
09	Local alarm reference
0A	Maximum alarm data length
0B	Alarm CRT Tag high
0C	Alarm CRT Tag low

10.8.16.0.15.13 Error Code 2 for Error Code 1 = 8

Error Code 2	Meaning
04	Sequence number
05	AR UUID
06	API
07	Slot number
08	Subslot number

Error Code 2	Meaning
09	Padding
0A	Index
0B	Data length
0C	Target AR UUID

10.8.16.0.16.14 Error Code 2 for Error Code 1 = 16

Error Code 2	Meaning
05	Padding
06	Session key
07	Padding
08	Control block command
09	Control block properties

10.8.16.0.17 PROFINET - Resolve Errors

NOTE

The errors listed in this topic apply to both controllers and devices except where identified.

- "Additional Analyses - Controllers Only" (→ p. 615)
- "CL-RPC Lookup - Devices Only" (→ p. 615)
- "Connect Response Error" (→ p. 616)
- "Device is not Found" (→ p. 616)
- "Error Setting the IP Configuration" (→ p. 616)
- "Module Configuration is Different" (→ p. 616)
- "Other Errors" (→ p. 616)
- "Writing Parameterization Error (with status 0xDF80*)" (→ p. 617)

10.8.16.0.18.1 Additional Analyses - Controllers Only

For further analyses, record the PNIO communication using [Wireshark](http://www.wireshark.org/) (http://www.wireshark.org/).

1. Start Wireshark.
2. In the **Capture** menu, click **Options**.
3. Choose the network interface used for the PNIO communication and enter this **Capture** filter text:

```
ether proto 0x8892 or (ether proto 0x8100 and ether[16:2]=0x8892) or udp
port 0x8894
```

4. Click **Start**.
5. Start the runtime with your application several times.
6. In the **Capture** menu, click **Stop** to stop the Wireshark capturing.
7. In the **File** menu, click **Save** to save the recorded traffic.

10.8.16.0.19.2 CL-RPC Lookup - Devices Only

10.8.17 Timeout Error

- Verify the IP configuration is valid and appropriate for the network.
- Increase the IP configuration delay.

10.8.17.0.1.1 Connect Response Error

10.8.18 Timeout Error

This Timeout Error sub-section was copied from the Device Resolve Errors topic - is this true for Controllers?

- Verify the IP configuration is valid and appropriate for the network.
- Increase the IP configuration delay.

Depending on the PNIO status error, check if the settings listed in this table are appropriate for your device.

PNIO Status	Check the Specified Setting
1C010003	Slave\ObjectUUID (correct GDML file)
DB8103,*	Slave\Module IDs, IOs
DB81010A	Master\Activity timeout factor
DB81010B	Master\Controller name
DB81010C	Master\Controller name
DB81020A	Master\Send clock factor
DB81020B	Slave\Reduction ratio
DB81020C	Slave\Phase
DB81020F	Master\Watchdog factor
DB810207	Master\RT-Class
DB810210	Master\Watchdog factor
DB810407	Master\Alarm timeout
DB810408	Master\Alarm retries

10.8.18.0.1.1 Device is not Found

- Verify:
 - If the device is switched on.
 - The network connection.
 - The correct name was set on the device.

10.8.18.0.2.2 Error Setting the IP Configuration

- Verify:
 - The IP configuration is valid and appropriate for the network.
 - The VLAN ID is setup correctly in the device settings.

10.8.18.0.3.3 Module Configuration is Different

- Verify:
 - The modules on the device are configured.
 - If the module configuration is read from the device, verify you have selected the correct modules in the **Resolve Ambiguous Modules** dialog that opens after selecting the GSDML file.
 - The correct GSDML file is chosen.
 - The GSDML file version is appropriate for the firmware version of the device.

10.8.18.0.4.4 Other Errors

- Verify:
 - The correct device name is used.
 - The correct GSDML file is chosen.
 - If the GSDML file version is appropriate for the firmware version of the device.

10.8.18.0.5.5 Writing Parameterization Error (with status 0xDF80*)

- Verify:
 - The modules on the device are configured.
 - If the module configuration is read from the device, verify you have selected the correct modules in the **Resolve Ambiguous Modules** dialog that opens after selecting the GSDML file.
 - The correct GSDML file is chosen.
 - The GSDML file version is appropriate for the firmware version of the device.
- If the error could not be resolved using these options, update the firmware of the device and the GSDML file to the latest version and try again.

10.8.19 Use Wireshark

For further analyses, record the PNIO communication using [Wireshark](http://www.wireshark.org/) (<http://www.wireshark.org/>).

1. Start Wireshark.
2. In the **Capture** menu, click **Options**.
3. Choose the network interface used for the PNIO communication and enter this **Capture** filter text:

```
ether proto 0x8892 or (ether proto 0x8100 and ether[16:2]=0x8892) or udp
port 0x8894
```

4. Click **Start**.
5. Start the runtime with your application several times.
6. In the **Capture** menu, click **Stop** to stop the Wireshark capturing.
7. In the **File** menu, click **Save** to save the recorded traffic.

10.8.20 Modular EtherCAT Concept

10.8.20.1 Introduction

A modular approach to machine design has many benefits, including flexibility, scalability, and improved efficiency.

- Modular machines are split into sub-sections.
- Each sub-section containing all the mechanical and electrical devices, motors, sensors, etc. as well as corresponding application code, to work together to provide a functional segment in the manufacturing workflow.
- The advantages to modular design are realized when the modules can be re-used.
- Examples include multiple module instances in the same machine and modules replicated across multiple machines.

Special consideration should be given to the physical layout, EtherCAT network topology, and the application code architecture to design a modular machine.

Modular machines are well suited to distributed EtherCAT device topologies (e.g., AKD-x-C/N drives) but can also be applied to other EtherCAT devices.

10.8.20.2 Examples of Modular Machine Design Uses

10.8.20.2.1 Machine with Multiple Variants

- a. Machine Variant = Base module + one, two, (or more) additional modules.
- b. Base Module - Each machine variant has the same base set of EtherCAT devices.
- c. Additional Modules - Each module contains one (or more) EtherCAT devices.

10.8.20.2.2 Module Maintenance

- a. One (or more) modules are removed during machine operation.
- b. The machine continues to operate with the remaining base + modules.

10.8.20.2.3 Share Modules across Machines in a Factory Line

- a. Remove a module from machine A.
- b. Continue to operate machine A with the remaining base + modules.
- c. Move the module to machine B.

10.8.20.3 Modular Design Guidelines

These sections provide guidelines for modular design:

Single project file (.kas) with maximum EtherCAT topology

1. Start with the full topology of EtherCAT devices planned for the maximum machine configuration.
2. Perform an EtherCAT scan to discover the full set of EtherCAT devices and save the project file.

The PLC code in the KAS project can be adapted to handle the cases where modules containing EtherCAT devices are disconnected and removed for different machine configurations, maintenance, etc.

PLCopen/Pipe Network Axis to drive map is the same for all machine variants

Map the axes to the drives for the maximum EtherCAT topology.

The axis to drive map remains consistent if drives are disconnected/removed.

Whether drives are disconnected and removed from the end or from the middle of an EtherCAT network, the axis to drive map relationship remain the same.

Axis is simulated for a disconnected drive

The PLC application code must be adapt to the disconnected/removed devices.

Because disconnected drives behave as simulated axes/drives, the application code can perform many normal axis operations without code adaptations.

This provides flexibility for how the application code is designed to handle disconnected/removed drives.

Safety devices should not be disconnected/removed

FSoE Masters may not support modular EtherCAT designs.

If a safety device is disconnected and removed, the FSoE master does not allow normal machine operation.

See ECATDeviceAction about how to add the ability to connect/disconnect an EtherCAT device to the program.

10.8.20.4 Backing up Modular EtherCAT Devices

This procedure should be followed to backup EtherCAT devices when the modular EtherCAT feature is used to remove devices to create a machine variant.

See "Modular EtherCAT Concept" (→ p. 617) for more information.

1. Run the KAS application which sets up the correct EtherCAT topology for the machine variant.
2. Stop the KAS application.

ⓘ IMPORTANT

Do not power cycle or reboot the controller between Steps 2 and 3.

3. Backup the EtherCAT devices.
See "Backup Procedure" (→ p. 391) for more information.

10.8.20.5 Limitations

- The device topology order cannot be rearranged.
- The Modular EtherCAT features are not supported with imported ENI files.

What happens when the device providing feedback to the digitizing axis is removed?

The feedback position becomes zero if the device providing the Feedback Position for the Digitizing axis is removed using the ECATDeviceAction function block.

The feedback position data coming from the device is automatically connected to the digitizing axis when the device is reconnected to the EtherCAT network.

The Restore function only supports exact matches in the topology of backedup EtherCAT devices.

The Restore function only supports conditions where the network topology exactly matches the topology of the EtherCAT devices backup.

- There are a number of possible permutations and combinations when the Modular EtherCAT feature is used to create a machine with multiple variants.
- If a machine has a base EtherCAT module and a varying number of optional EtherCAT modules, then it is recommended that multiple backups are created:
 - A base EtherCAT module backup and an optional EtherCAT module backup.

Example

This image shows a base EtherCAT module and a varying number of optional type A modules and type B modules.

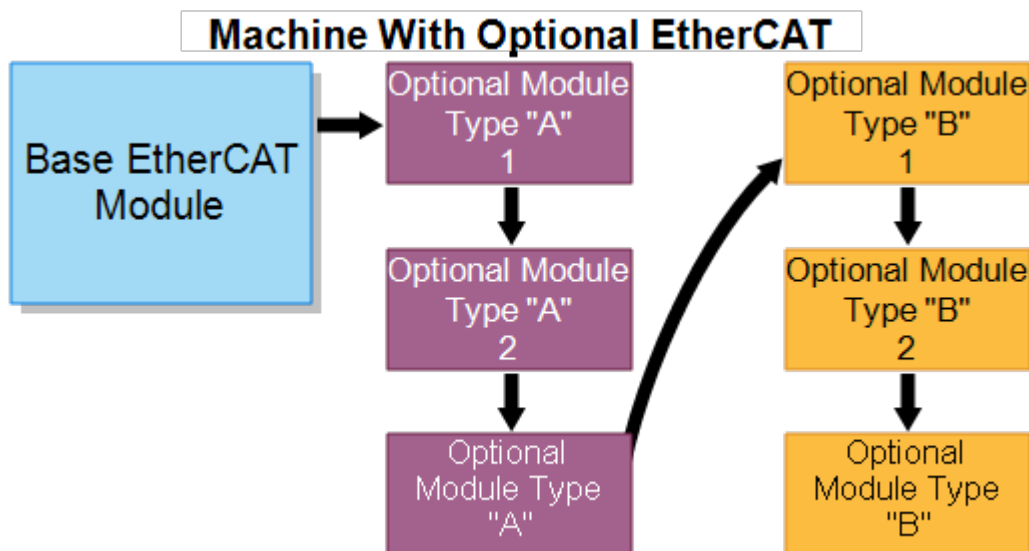

We recommend that EtherCAT Devices backups be made with the following configurations in order to meet different scenarios.

- Backup #1: Base EtherCAT Module + one of Optional Module Type A.
- Backup #2: Base EtherCAT Module + one of Optional Module Type B.

With the two EtherCAT Devices backups, you may be able to restore various combinations by removing the other Optional Modules, keeping only the module you need to restore.

10.8.20.6 Create an Application with Modular EtherCAT

This section discusses how to create an application with modular EtherCAT for various scenarios. We will use the following configuration to describe the scenarios and code snippets. The configuration consists of a full machine with two different modules. The full EtherCAT network consists of seven devices.

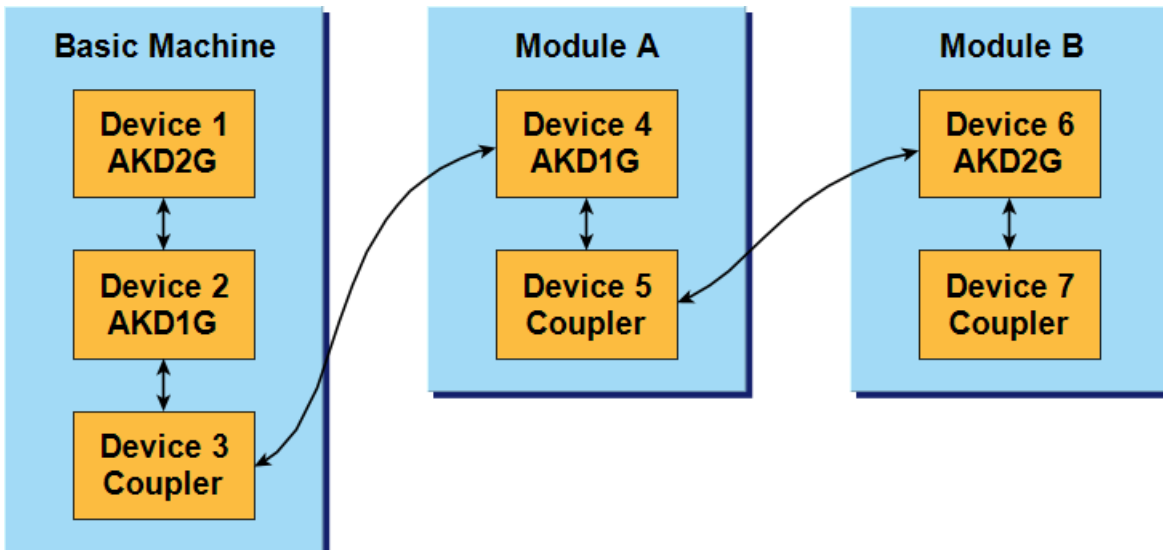

10.8.20.6.1 Create a Machine Variant with the Basic Machine

1. As described in the "Modular Design Guidelines" (→ p. 618), start with a full topology of EtherCAT devices. In this example we have Device1 to Device7.
2. After initializing the motion engine use the ECATDeviceAction function block to disconnect Device 4, Device 5, Device 6, and Device 7 **before** calling the MLMotionStart function block.
3. After the devices are disconnected, call MLMotionStart and finish the code.

10.8.20.6.2 ST Language Example

```

/////MOTION INITIALIZATION//////////////////////////////////////

FirstCycle := TRUE;

On FirstCycle DO //Initialize the motion engine
    MLMotionInit( 1000);
    StatusMessage := 'Initializing Motion Engine';
END_DO;

MotionEngineStatus := MLMotionStatus();//Check the current status of the
motion engine

ON MotionEngineStatus = MLSTATUS_INITIALISED DO//Once motion engine is
initialized, create CAM profiles and defined Axis, then start the motion
engine
    If not FirstInitComplete then
        Profiles( MLPR_CREATE_PROFILES );
        PLCopen( 0 );
        // Disconnect Device 4 through Device 7
        Inst_ECATDeviceAction(True, EtherCAT.Device_4 , DEVICE_ACTION_
DISCONNECT);
        if Inst_ECATDeviceAction.Error then
            //Handle the Error here
        End_if;
        // Repeat the steps done for Device 4 to disconnect Device 5,Device
6, Device 7
        // After disconnecting all the devices that are not part of this
  
```

```

machine variant, start the motion engine.
    MLMotionStart();
    FirstInitComplete := True;
End_If;
END_DO;

```

10.8.20.6.3 Add a Module

Use this procedure when a module needs to be added.

In this example we will add Module A of our example project.

1. Stop the motion engine using MLMotionStop.
2. Verify that motion engine is stopped.
3. Use the action "DEVICE_ACTION_CONNECT" in ECATDeviceAction to connect the EtherCAT devices (Device 4 and Device 5) corresponding to the module.
4. Start the motion engine using MLMotionStart.

10.8.20.6.4 ST Language Example

```

// To Add a Module first stop the Motion Engine.
MLMotionStop();
MotionEngineStatus := MLMotionStatus();//Check the current status of the
motion engine

ON MotionEngineStatus = MLSTATUS_STOPPED DO

    // Connect Device 4 and Device 5 to add Module A
    Inst_ECATDeviceAction(True, EtherCAT.Device_4, DEVICE_ACTION_CONNECT);
    If Inst_ECATDeviceAction.Error then
        //Handle the Error here
    End_if;
    Inst_ECATDeviceAction(True, EtherCAT.Device_5, DEVICE_ACTION_CONNECT);
    If Inst_ECATDeviceAction.Error then
        //Handle the Error here
    End_if;

    // Start the Motion Engine
    MLMotionStart();

END_DO;

```

10.8.20.6.5 Remove a Module

Use this procedure when a module needs to be removed.

In this example we will add Module A of our example project.

1. Stop the motion engine using MLMotionStop.
2. b. Verify that motion engine is stopped.
3. Use the action "DEVICE_ACTION_DISCONNECT" in ECATDeviceAction to disconnect the EtherCAT devices (Device 4 and Device 5) corresponding to the module.
4. Start the motion engine using MLMotionStart.
5. See the code snippet below for ___?

10.8.20.6.6 ST Language Example

```

// To remove a Module first stop the Motion Engine.
  MLMotionStop();
  MotionEngineStatus := MLMotionStatus();//Check the current status of the
motion engine

ON MotionEngineStatus = MLSTATUS_STOPPED DO

  // Disconnect Device 4 and Device 5 to add Module A
  Inst_ECATCHDeviceAction(True, EtherCAT.Device_4, DEVICE_ACTION_
DISCONNECT);
  If Inst_ECATCHDeviceAction.Error then
    //Handle the Error here
  End_if;

  Inst_ECATCHDeviceAction(True, EtherCAT.Device_5, DEVICE_ACTION_
DISCONNECT);
  If Inst_ECATCHDeviceAction.Error then
    //Handle the Error here
  End_if;

  // Start the Motion Engine
  MLMotionStart();

END_DO;

```

10.8.21 Controller Performance Guidelines

Time to share the data over EtherNet/IP or PROFINET does not increase as more variables are shared unless either the:

- EtherNet/IP Requested Packet Interval (RPI) time is changed.
- PROFINET Send clock factor is changed.
- PCMM2G processor is overloaded (i.e., no idle time).

Additional controller CPU usage is required when fieldbuses are used to transmit and receive data between network devices and PLC variables.

The impact to the PLC execution time and the CPU load is estimated as:

$$\text{EtherNet/IP or PROFINET Processing Time} = \text{PLC Overhead} + (\text{Bytes Shared} \times \text{Load per Byte})$$

These models are used to calculate the performance of the EtherNet/IP and PROFINET fieldbuses.

- "AKD PDMM and PCMM - 800MHz" (→ p. 623)
- "AKD PDMM and PCMM - 1.2GHz" (→ p. 623)
- "PCMM2G" (→ p. 623)

Notes

- The **Load per Byte** is dependent on both the:
 - EtherNet/IP RPI.
 - PROFINET Send clock factor.

- The **Load per Byte** values are measured with both:
 - EtherNet/IP: RPI = 10.
 - PROFINET: Send clock factor [31,250us] = 32.

10.8.21.1 AKD PDMM and PCMM - 800MHz

AKD PDMM and PCMM 800MHz as an:	PLC Overhead	Load per Byte
EtherNet/IP Adapter (Server)	42 microseconds	0.5258 microsecond/Byte
EtherNet/IP I/O Scanner (Client)	42 microseconds	0.4603 microsecond/Byte

10.8.21.2 AKD PDMM and PCMM - 1.2GHz

AKD PDMM and PCMM 800MHz 1.2GHz as an:	PLC Overhead	Load per Byte
EtherNet/IP Adapter (Server)	28 microseconds	0.3121 microsecond/Byte
EtherNet/IP I/O Scanner (Client)	25 microseconds	0.269 microsecond/Byte
PROFINET IO Controller	54 microseconds	0.515 microsecond/Byte
PROFINET IO Device	25 microseconds	0.235 microsecond/Byte

10.8.21.3 PCMM2G

PCMM2G as an:	PLC Overhead	Load per Byte
EtherNet/IP Adapter (Server)	15 microseconds	0.0922 microsecond/Byte
EtherNet/IP I/O Scanner (Client)	10 microseconds	0.0753 microsecond/Byte
PROFINET IO Controller	22 microseconds	0.156 microsecond/Byte
PROFINET IO Device	13 microseconds	0.119 microsecond/Byte

10.8.21.4 Example: EtherNet/IP Performance

This example uses an PCMM2G as an I/O Scanner with 8x Assemblies with:

- 3968 Byte PLC variables all with RPI 10ms.
- 4000 microsecond EtherCAT Cycle Time.

```
PLC Time = (3968 x 0.0922) + 15 = 381 microseconds
CPU Usage % = 381 / 4000 = 0.095 (9.5%)
```

Results of exchanging data over EtherNet/IP:

- Increases the PLC execution time by 381 microseconds.
- Reduces the CPU Idle Time by 9.5%.

10.9 Project Structure Guidelines

By implementing a predefined structure for new projects, KAS tries to achieve these goals:

- Efficiency in developing new applications
- High flexibility to keep only functionalities that are needed and to create the new ones that are required
- Safe applications due to an already tested and approved structure that optimize the resources usage (memory and processor load)
- Reliable framework that supports error, state, data and communication management
- Easier to exchange applications



- Less time needed to understand, maintain and teach an application (from a troubleshooting and support standpoint)
- Less documentation work is required since the main behavior of the Application is already documented (only the specific functionalities need some additional work)

10.9.1 External Files

Some items that belong to the application (shown in the "Project Explorer" (→ p. 71)) are not embedded into the project file.

For the domains listed in this table, KAS-IDE uses some resources stored in external files.

TIP
The links open the relevant topic with more details.

Domain	Description	File
Drive 	<p>The AKD drive is fully embedded in the Kollmorgen Automation Suite but not all interwoven at one time.</p> <p>This makes future customization easier to get all the firmware features.</p>	"FAQs" (→ p. 823)
Fieldbus	Kollmorgen Automation Suite tightly integrates the EtherCAT motion bus (standard Ethernet-based cabling) to define all the network description.	"Import or Export an EtherCAT ENI File" (→ p. 329)
HMI 	<p>Using Kollmorgen HMI, tag the variables in the PLC environment to create an export file that describes the data to be exchanged between the PLC and the HMI.</p> <p>Import this Modbus mapping file into the HMI programming environment and use the variables as if they are local variables.</p>	"Add an HMI Device" (→ p. 185)
Motion	<p>The CAM editor is used to create complex CAM profiles online using a "graphical" interface.</p> <p>It is also possible to import existing CAM profile points into the CAM editor to reuse the existing machine building experience seamlessly.</p>	<ul style="list-style-type: none"> • "Import a CAM Profile" (→ p. 455) • "How Do I Export the Oscilloscope Data?" (→ p. 497)
PLC	<p>The PLC programming environment is used to create reusable components (UDFB) and template applications.</p> <p>These can be customized to suit any given application.</p>	<ul style="list-style-type: none"> • "Create and Use Custom Libraries" (→ p. 209) • "Use the Defines List" (→ p. 311)

10.9.2 Application Software Structure - Definitions

10.9.2.1 Modules to Build up the Structure

- "Structure Overview" (→ p. 624)
- "Main Module" (→ p. 625)
- "Axis Module" (→ p. 626)

10.9.2.1.1 Structure Overview

You normally write the PLC program. In most cases, Kollmorgen application team members create the motion control part.

The global software structure is built with different modules placed on different levels:

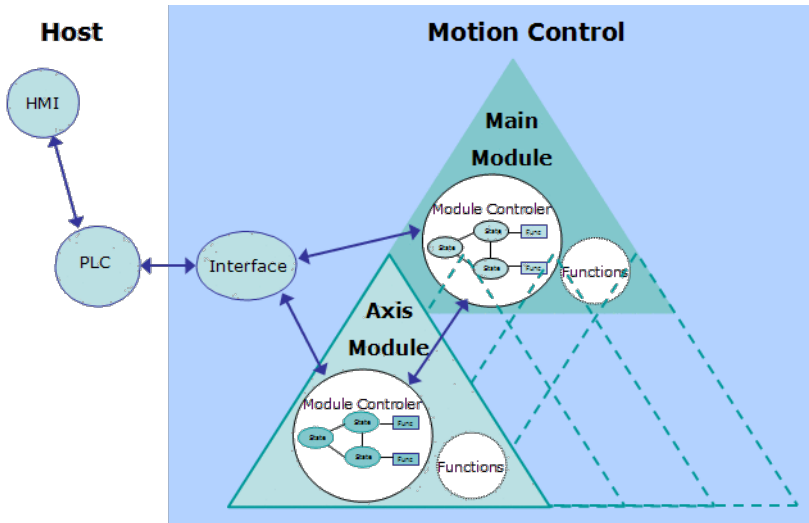

Figure 11-21: Software Structure Overview

Module Definition

- A module is one unit of the software structure (triangle)
- It is controlled by one module from the next higher level and can in turn control several modules in the next lower level
- It never communicates with modules of the same level
- It can generally run independently from any other modules at the same or higher level

To have the structure running as a real application, it needs to be controlled by a PLC. As the PLC is not part of the application structure, only the main and axis modules are described here.

10.9.2.1.2 Main Module

The main module controls the functional work that globally affect the application (e.g. multi axes functions). It receives commands from the PLC and sends back acknowledgements. The main module does not directly act on the physical axes, but controls the axis modules that are linked to them.

Communication between main and axis modules is done via internally defined data channels.

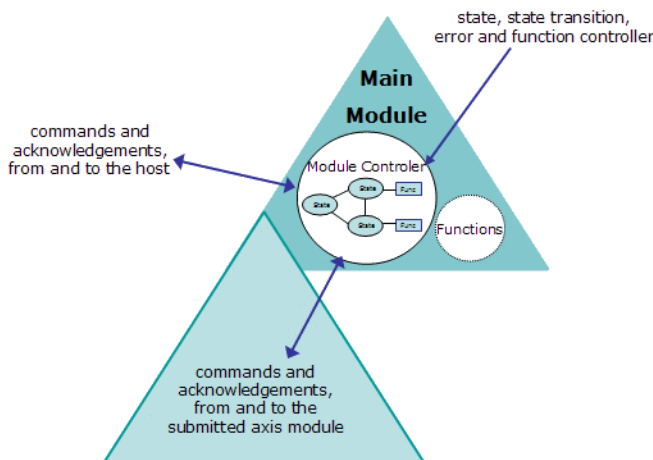

Figure 11-22: Main Module Description

As shown in the "Main Module Description" (→ p. 625) image, the module consists of two parts:

10.9.2.1.3.1 Module Controller

- This part is responsible for state, state transition, error and functions handling.
- It receives state transition and function call commands from the host, performs all needed actions and sends back some acknowledgments.
- In case of an error, it reacts by itself and sends a message to the PLC.
- If requested, it activates state transitions and functions in the axis modules, by sending commands to them and waiting for acknowledgment.
- The main module controller also manages the error status of the submitted modules and performs the needed actions.

10.9.2.1.4.2 Functional Part

- This consists of all functionalities needed for the current application.
- These functions can be state dependent (e.g., multi-axes functions) or state independent (e.g., increase a speed value).

10.9.2.1.5 Axis Module

The axis module controls the functional work that affect the application one or more physical axes (e.g., single-axis functions). It receives commands from the PLC and sends back acknowledgments.

The axis module also communicates with its main module via the internally defined data channel.

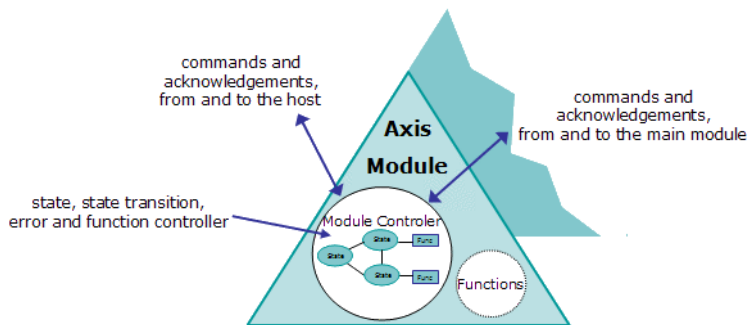

Figure 11-23: Axis Module Description

As shown in the "Axis Module Description" (→ p. 626) image, the axis module consists of the same "Module Controller" (→ p. 626) and "Functional Part" (→ p. 626) two parts as the main module with this Module Controller addition:

10.9.2.1.6.1 Axis Module Controller

- If the axis module is **not** connected to its main module:
 - It receives state transition and function call commands from the host.
 - Performs all needed actions and sends back some acknowledgments.
- If the axis module is connected, state transition commands are received from its main module and not from the host.
 - In case of an error it only reacts by itself, if it is not connected to the main module.

10.9.2.2 State and Function Definitions

A state machine and some functions of general interest are implemented in the software structure.

- They are provided as examples of how to use the structure but can be adjusted to fulfill specific application usage.
 - See (→ # 633, Add a New State) and (→ # 629, Add a New Function) for more information.
- All modules have the same states and state transitions.
 - The state of a module is only influenced by other modules, if they are connected with each other.

The state machine has been defined.

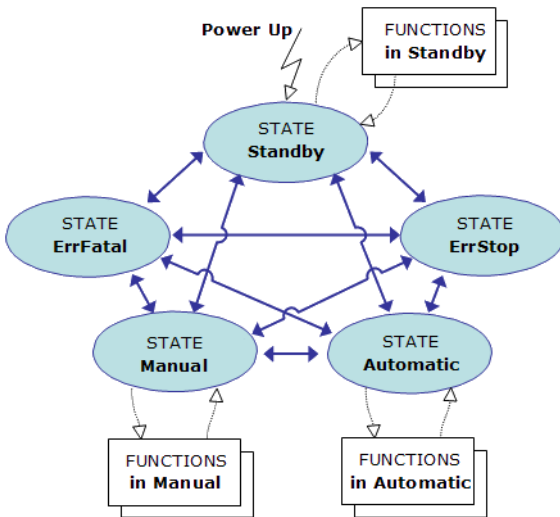

Figure 11-24: State Machine

Image Legend	Description
	Represents the current state of one or more modules (e.g., Standby state means the module is waiting for commands). In addition to the static states, there are two other dynamic states: <ul style="list-style-type: none"> • Busy: When performing a state transition (exit old and enter new state). • Running: When working through a function.
State Transition 	It is the transition from one state to another when performing the corresponding action.
	Any needed machine or single-axis functionality (e.g., single-axis jog), which can be called out of one or several states.

10.9.2.2.1 State, State Transitions and Functions

The structure is built so state transitions are possible from the active state to any other existing states (except state ErrStop).

- After leaving state ErrStop (corresponding to a non-fatal error, which causes a stop and power off) the structure automatically recovers the state which was active before entering ErrStop.
 - This means that all characteristics of the previous state are kept.

NOTE

Because functionalities are always specific to the application, none are included in the structure itself.

10.9.3 Application Software Structure - Implementation

This section describes how the software structure described before is implemented. Insofar as all modules are implemented and behave in the same way, only the main module is described in detail here.

10.9.3.1 SFC Children Building up the Software

These files contain all the data to build up the application.

They are all required to ensure a successful compilation.

10.9.3.1.1 Parent SFC

File	Description
Main	System start up and SFC children call

10.9.3.1.2 Main Module SFC Children

File	Description
M1_StateController	state and function controller of the main module
M1_ErrorHandling	error handling of the main module
M1_IndependentFunctions	state independent functions of the main module
M1_Interface	interface to PLC

10.9.3.1.3 Axis Module SFC Children

With $i = 1 \dots n$

File	Description
Ai_StateController	state and function controller of the axis module
Ai_ErrorHandling	error handling of the axis module
Ai_IndependentFunctions	state independent functions of the axis module

10.9.3.2 Functions Linked to States

10.9.3.2.1 Functions Treatment

The "Function Treatment" (→ p. 628) image shows how functions (that are state dependent) are treated.

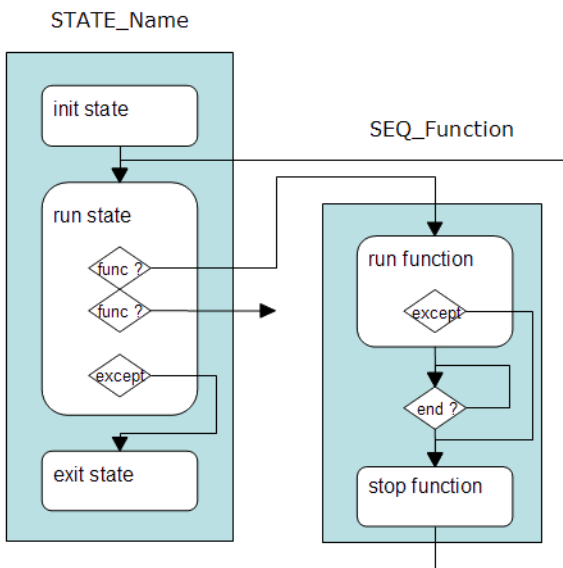

Figure 11-25: Function Treatment

10.9.3.2.2.1 Function (Function Step)

Function	Description	Example
Run Function	<ul style="list-style-type: none"> Initializes exceptions on new state M1_CmdState <> M1_ReqState and on errors set in M1_StatusWord. Goes to exit function when an exception occurs. Acknowledges running. Performs all actions needed for the function until the function call command is reset. 	
Stop Function	<ul style="list-style-type: none"> Performs all actions to properly leave this function. Acknowledges end of exit, by setting M1_AckState to M1_ReqState. Returns to last state. 	

Figure 11-26:
Change State > Error Stop > State

10.9.3.2.3 Add a New Function

1. Copy a similar existing function sequence.
2. Replace the old function name by the new one (e.g., Running replaced with MyFunction).
3. Modify the exit section of the new function to perform the relevant actions.
4. Insert the needed function code into the run part.
5. Add the function call command line to the state sequence where the function is used.

10.9.3.3 Main Module Implementation

In the main module, all necessary state, state transition, error and function handling facilities are implemented for this level.

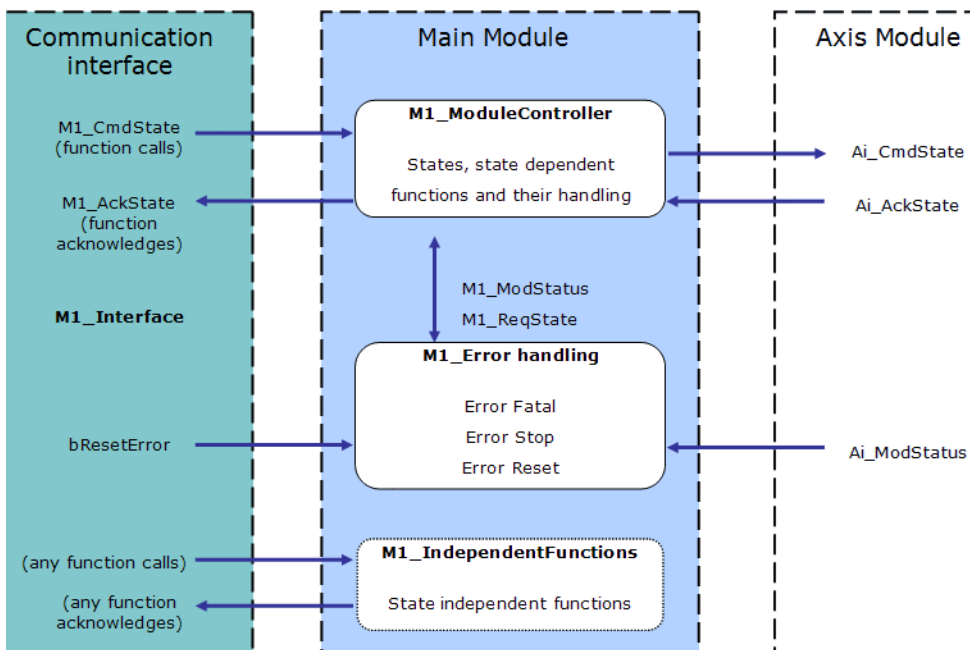

Figure 11-27: Context Diagram for Main Module

These objects (variables, tasks...) are defined in the structure of the main module.

- "bErrorReset" (→ p. 630)
- "M1_AckState" (→ p. 630)
- "M1_CmdState" (→ p. 630)
- "M1_ErrorHandling" (→ p. 630)
- "M1_ModStatus, (Ai_ModStatus)" (→ p. 631)
- "M1_ModuleController" (→ p. 631)
- "M1_ReqState" (→ p. 632)

10.9.3.3.1 bErrorReset

This internal flag variable is used as the error reset command for the main and axis modules. It is reset during power up.

Usage

- Set and reset this flag to activate a reset of the module errors (M1_StatusWord, Ai_StatusWord).

10.9.3.3.2 M1_AckState

This internal word variable contains the actual state acknowledge value, as a result from the **M1_CmdState** state command performed with success.

- Possible values are the same as for the state commands.
 - See "M1_CmdState" (→ p. 630).

Usage

- The corresponding acknowledgments for the PLC can be created in the communication interface.

10.9.3.3.3 M1_CmdState

This internal word variable contains the actual state command value.

It is automatically set to state **Standby** during power up.

```

//*****
/**          State Defines          **
//*****
#define DEF_StateUndefined          0
#define DEF_StateStandby           1
#define DEF_StateManual             2
#define DEF_StateAutomatic         3
#define DEF_StateBusy              4
#define DEF_StateErrorStop         5
#define DEF_StateErrorFatal        6
    
```

Usage

- State commands are usually set in the communication interface (see software listing of ACT_M1_Translate and ACT_M1_SimaticSimu) and must not be set directly from the host system.
- If additional or different state commands are needed, the definitions can be modified.

10.9.3.3.4 M1_ErrorHandling

This program is responsible for the main module error handling.

- If an error occurs (in the main module or a submitted axis module), the corresponding bit in the module status (M1_StatusWord) is set.

- This causes the error reaction bits (`MSK_Mi_StatusErrorStop`, `MSK_Mi_StatusErrorFatal`) to be set in the module status word.

Usage

- Any additional error which needs to be treated has to be included in this program.
- Remember to modify the corresponding masks (`MSK_M1_StatusErrorFatal`, `MSK_M1_StatusErrorStop`) to cause the correct reaction on errors.

10.9.3.3.5 M1_ModStatus, (Ai_ModStatus)

This internal word variable contains the actual module status and error information.

- It is automatically set to the default value during power up.
- The meaning of the predefined **Module Error Bits** are:

Bit	Description
0	Error stop reported by drive (drive error).
1	Error fatal reported by Drive (lag error).
2	Not used (motor temperature too high).
3	Not used (external stop).
4	Not used (negative limit switch reached).
5	Not used (positive limit switch reach).
6	Not used (not used).
7	Not used (not used).
8	Not used (state HW enable)
9	Not used (state AS enable).
10	Not used (axis is powered on).
11	Not used (axis is homed).
12	Not used (axis is running).
13	Not used (pipe is connected).
14	Error stop (error stop).
15	Error fatal (error fatal).

Usage

- The error bits are usually set only by the error handling (`M1_ErrorHandling`).
 - The mode bits can be modified where ever needed in the application program (except in the interface).
 - Several bits can be set at the same time.
- Several masks have been defined to test or modify the whole word.
 - For each module, there is one mask to define the bits causing a fatal error (e.g. `MSK_M1_StatusErrorFatal`) and one for the stop error (e.g. `MSK_M1_StatusErrorStop`).
- To add errors and modes, the bits not already assigned by default can be used (i.e. bits 16 to 31).

10.9.3.3.6 M1_ModuleController

This program is the heart of the whole controller and contains:

- A state manager sequence.
- All state sequences.
- State dependent function sequences of the main module.

Usage

- Some rules have to be followed when using and changing states and functions.
 - See (→ # 633, Add a New State) and (→ # 629, Add a New Function) for more information.

10.9.3.3.7.1 M1_ReqState

This internal word variable contains the internally active state.

- It is used for internal purpose only, to keep the actual state value (e.g., while performing a function).
 - Possible values are the same as for the state commands.
 - See "M1_CmdState" (→ p. 630).

Usage

- Used by system, **do not use** for application purposes.

10.9.3.4 States and Errors

10.9.3.4.1 States and Errors Treatment

The "State and Error Treatments" (→ p. 632) image shows how states and errors are treated.

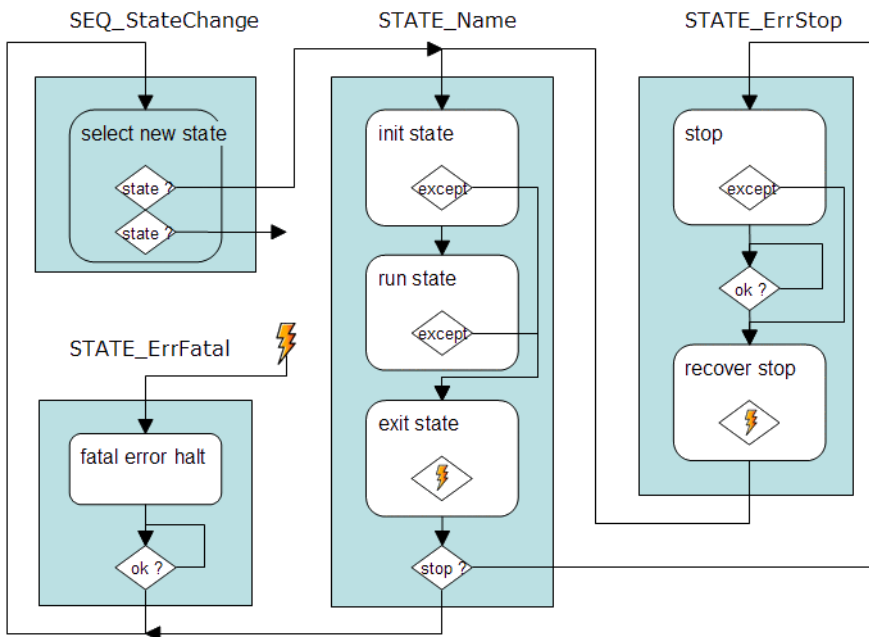

Figure 11-28: State and Error Treatments

StateChange (state manager): Activates the new state required by M1_ReqState.

StateName (state macro).

State	Description
Init State	<ul style="list-style-type: none"> Initializes exceptions on new state M1_CmdState <>¹ M1_ReqState and on errors set in M1_StatusWord. Goes to exit state when an exception occurs. Performs all actions to properly enter this state (e.g., init variables, pipes, etc.) Sends commands to the submitted axis modules by: <ul style="list-style-type: none"> Setting Ai_CmdState to StateName. Waiting for their acknowledgment in Ai_AckState. Acknowledges end of initialization by setting M1_AckState to M1_ReqState.
Run State	<ul style="list-style-type: none"> Waits for any function calls. Activates function if called.
Exit State	<ul style="list-style-type: none"> Performs all actions to properly leave this state. Acknowledges running by setting M1_AckState to busy. If error stop occurs, activates STATE_ErrStop. <ul style="list-style-type: none"> Otherwise, sets new requested state M1_ReqState to M1_CmdState and activates StateChange.

10.9.3.4.2 Add a New State

1. Copy a similar existing state sequence.
2. Replace the old state name by the new one (e.g., Standby replaced with MyState).
3. Modify both init and exit sections of the new state to perform the relevant actions.
4. Insert the needed function calls into the states run part.
5. Add the state call command line into the state change sequence.
6. Add the state definition values to the general declaration.

10.9.3.5 Variables for the Interface

10.9.3.5.1 List of Variables

- bAi_CallAutomaticFunction1
- bAi_CallAutomaticFunction2
- bAi_CallManualFunction1
- bAi_CallManualFunction2
- bAi_CallStandbyFunction1
- bAi_CallStandbyFunction2
- bErrorReset
- bM1_CallAutomaticFunction1
- bM1_CallAutomaticFunction2
- bM1_CallManualFunction1
- bM1_CallManualFunction2
- bM1_CallStandbyFunction1
- bM1_CallStandbyFunction2
- M1_CmdState

10.9.3.5.2 List of Output Variables

- Ai_StatusWord
- bAi_Running
- bM1_Running

¹<> means Not Equal

- M1_AckState
- M1_StatusWord

10.10 Project Templates

KAS provides start up templates to help you get started.

See "Add the Controller" (→ p. 133) to use the project setup wizard.

These are the templates for the Pipe Network and PLCopen motion engines:

- "Coordinated Motion" (→ p. 634)
- "KAS Runtime" (→ p. 634)
- "KDN Download" (→ p. 634)
- "Pipe Network" (→ p. 634)
- "PLCopen" (→ p. 635)

10.10.1 Coordinated Motion

Template Name	Description
"Coordinated Motion - 2-Axis Template" (→ p. 636)	<ul style="list-style-type: none"> • Linear / Circular • Raster Scan Motion Path • 2 PLCopen axes
"Coordinated Motion - 3-Axis Template" (→ p. 637)	<ul style="list-style-type: none"> • Linear / Circular • Raster Scan Motion Path • 1 Pipe Network axis • 2 PLCopen axes
"Coordinated Motion - 3-Axis (3D) Template" (→ p. 638)	<ul style="list-style-type: none"> • Linear 3D • Diamond / Square Motion Path • 3 PLCopen axes

10.10.2 KAS Runtime

Template Name	Description
Library	Used to create a custom library. See also see "Create and Use Custom Libraries" on page 209.

10.10.3 KDN Download

Template Name	Description
KDN	<ol style="list-style-type: none"> 1. Click Finish to close the dialog. A web browser page opens on KDN with custom-built template files. The template files may have enhanced or specific functionality. 2. Download and save a template file. 3. Open it from KAS-IDE.

10.10.4 Pipe Network

Template Name	Description
"Pipe Network 1-Axis Template - FFLD" (→ p. 641)	Simple initialization, relative position move.

Template Name	Description
"Pipe Network 1-Axis Template - ST" (→ p. 641)	Simple initialization, relative position move.
"Pipe Network 2-Axes Template - FFLD" (→ p. 650)	Position and velocity moves, gearing, camming, and drive status.
"Pipe Network 2-Axes Template - ST" (→ p. 647)	Position and velocity moves, gearing, camming, and drive status.
"Pipe Network 2-Axes Template - FBD, FFLD, SFC, and ST" (→ p. 642)	Position and velocity moves, gearing, camming, and drive status with optimized performance.

10.10.5 PLCopen

Template Name	Description
"PLCopen 1-Axis Template - FFLD" (→ p. 653)	Simple initialization, relative position move.
"PLCopen 1-Axis Template - ST" (→ p. 654)	Simple initialization, relative position move.
"PLCopen 2-Axes Template - FFLD" (→ p. 663)	Position and velocity moves, gearing, camming, and drive status.
"PLCopen 2-Axes Template - ST" (→ p. 659)	Position and velocity moves, gearing, camming, and drive status.
"PLCopen 2-Axes Template - FFLD and SFC" (→ p. 655)	Position and velocity moves, gearing, camming, and drive status with optimized performance.

10.10.6 Template Inclusions

These templates come complete with software to:

- Create two or three axes of servo motion
- Enable the drives
- Perform simple motion

The templates contain variables which support these operations.

Name	Type	Dim.	Attrib.	Init value
TravelSp...	LREAL			LREAL...
MasterA...	LREAL			LREAL...
MasterDe..	LREAL			LREAL...
Machine...	LREAL			LREAL...
Axis1Sta...	DINT			
Axis2Sta...	DINT			
Machine...	DINT			0
bMaster...	BOOL			FALSE
bMaster...	BOOL			FALSE
bESop...	BOOL			FALSE
bLedStat...	BOOL	[0..3]		
Profiles	ProfilesCo...			
EtherCAT	EtherCAT...		Read Only	
PipeNet...	PNCCode			
Retain variables				
MachineLogic				
lastTrave...	LREAL			LREAL...
lastMach...	LREAL			LREAL...

Additionally, the templates contain a [Control Panel](#) for ease of running motion.

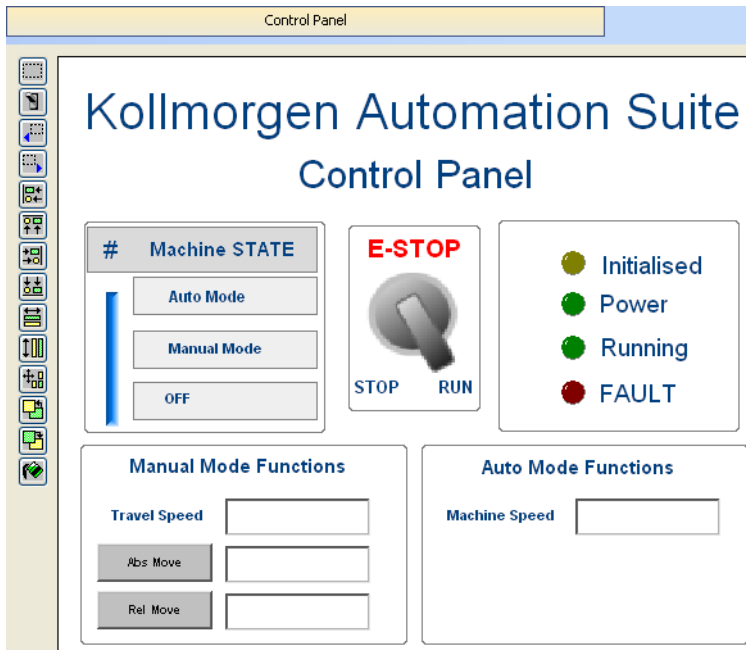
**NOTE**

The templates may need to be changed to run on specific hardware.

10.10.7 Coordinated Motion

- "Coordinated Motion - 2-Axis Template" (→ p. 636)
- "Coordinated Motion - 3-Axis Template" (→ p. 637)
- "Coordinated Motion - 3-Axis (3D) Template" (→ p. 638)

10.10.7.1 Coordinated Motion - 2-Axis Template

This project controls two axes in coordinated motion (PLCOpenAxis1 and PLCOpenAxis2).

10.10.7.1.1 Programs

The program is a Sequential Function Chart (SFC) containing both Structured Text (ST) and Free Form Ladder Diagram (FFLD) code.

- Steps 1 to 5 of the SFC create and initialize the axes and the coordinated motion axes group.
- Step 6 of the SFC interfaces with the Control Panel and performs a back-and-forth coordinated motion pattern with the two axes.
- The program utilizes coordinated motion direct moves, linear moves, circular moves, transitions and blending.

10.10.7.1.2 Motion Procedure

1. Download and start the application.
2. Press the **Enable** button to enable the axes and the axes group.
3. Optional: Press the **Home** button to move the axes to their zero position.
4. When the **Ready** light is on, turn the **Cycle Start** switch to 1.
The axes begin moving in the programmed pattern.

10.10.7.1.3 Control Panel

#	Description	GUI
1	Used to change the coordinated motion feedrate from 0% to 200%.	
2	Displays the axis positions.	
3	Indicator light. <ul style="list-style-type: none"> • Ready indicates: <ul style="list-style-type: none"> • The axes are enabled. • The axes group is ready and enabled for coordinated motion. 	
4	Begins the coordinated motion pattern.	
5	<ul style="list-style-type: none"> • Causes an Emergency Stop for all axes. • The axes are disabled. 	
6	<ul style="list-style-type: none"> • Resets the Emergency Stop. • Clears axis errors. • Enables the axes. 	
7	Disables the axes or axes group.	
8	Enables the axes and the axes group.	
9	Moves all axes or axes group to their zero position.	
10	Causes a reference by setting the axes' position to zero at their current location.	

10.10.7.2 Coordinated Motion - 3-Axis Template

This project controls two axes in coordinated motion (PLCOpenAxis1 and PLCOpenAxis2), and a third independent axis (VERTICAL_AXIS).

This template demonstrates how to use coordinated motion PLCopen axes and a Pipe Network axis.

10.10.7.2.1 PLC Programs

The Coordinated Motion 3-Axis template has a Sequential Function Chart (SFC) program containing both Structured Text (ST) and Free Form Ladder Diagram (FFLD) code.

- Steps 1 to 5 of the SFC program create and initialize the axes and the coordinated motion axes group plus the Pipe Network axis.
- Step 6 of the SFC interfaces with the Control Panel and performs a back-and-forth coordinated motion pattern with the two axes.
- The program utilizes coordinated motion direct moves, linear moves, circular moves, transitions and blending.
 - It performs basic moves for the third (Pipe Network) axis, to move down/up before and after the coordinated motion pattern.

10.10.7.2.2 Motion Procedure

This template uses both motion engines (Pipe Network and PLCopen) simultaneously.

ⓘ IMPORTANT

Coordinated motion can only be performed with PLCopen axes, Pipe Network axes do not support this feature. PLCopen axes that perform coordinated motion can be mixed with independent Pipe Network axes.

There is no axis synchronization at the Motion Engine level between a PLCopen axis and a Pipe Network axis. Any synchronization between the axes must be performed inside the PLC application.

1. Download and start the application.
2. Press the **Enable** button to enable the axes and the axes group.
3. Optional: Press the **Home** button to move the axes to their zero position.
4. When the **Ready** light is on, turn the **Cycle Start** switch to 1.
The axes begin moving in the programmed pattern.

10.10.7.2.3 Control Panel

#	Description	GUI
1	Used to change the coordinated motion feedrate from 0% to 200%.	
2	Displays the axis positions.	
3	Indicator lights. <ul style="list-style-type: none"> • Ready indicates: <ul style="list-style-type: none"> • The axes are enabled. • The axes group is ready and enabled for coordinated motion. • Error Stopped indicates the axes group has been stopped and disabled by the E-Stop button. 	
4	Begins the coordinated motion pattern.	
5	<ul style="list-style-type: none"> • Causes an Emergency Stop for all axes. • The axes are disabled. 	
6	<ul style="list-style-type: none"> • Resets the Emergency Stop. • Clears axis errors. 	
7	Disables the axes or axes group.	
8	Enables the axes and the axes group.	
9	Moves all axes or axes group to their zero position.	
10	Causes a reference by setting the axes' position to zero at their current location.	

10.10.7.3 Coordinated Motion - 3-Axis (3D) Template

This project template controls three axes in coordinated motion (PLCOpenAxis1, PLCOpenAxis2, and PLCOpenAxis3).

- It demonstrates how to use 3D coordinated motion, transitions, blending and a homing cycle with PLCopen axes.
- The path follows a square and diamond pattern on a plane which is rotated ~12.5 degrees about the Y axis with the center of rotation located at Z=30 X=-160.

This is the pattern and the platform for the plane:

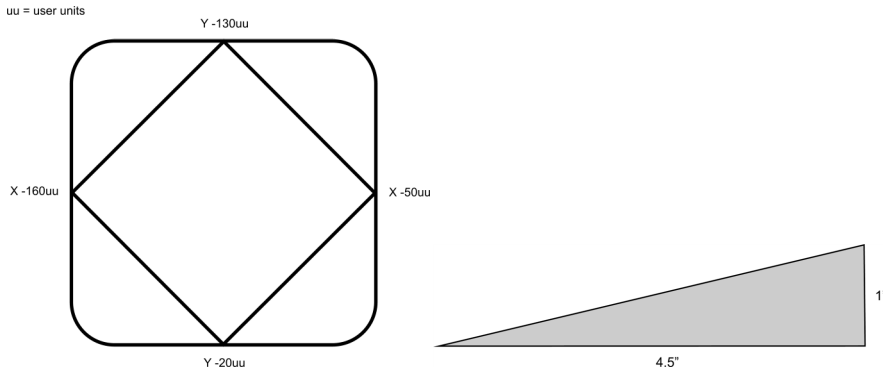
**NOTE**

This program is designed to run on the 3-Axis Demonstration machine shown in the video. It uses the machine's physical end-limit switches for the homing sequence. To run this program on different hardware, press the **Sim Mode** button on the Control Panel. This causes the program to execute in simulator mode and bypasses the homing sequence. The axis scaling parameters (entered in the PLCopen Axis Data dialogs) may need to be changed to accommodate the different hardware.

10.10.7.3.1 PLC Programs

The Coordinated Motion 3-Axis template has a Sequential Function Chart (SFC) program containing both Structured Text (ST) and Free Form Ladder Diagram (FFLD) code.

- Steps 1 to 5 of the SFC program create and initialize the axes and the coordinated motion axes group.
- Step 6 specifies the coordinates of the square and diamond pattern.
 - These coordinates are then rotated about the Y-axis.
- Step 7 monitors the Control Panel and performs two main functions.
 - The first function is to reference the axes to establish a home position.
 - The second function is to perform the 3-axis coordinated motion moves of the square diamond pattern.

This program provides examples of coordinated motion linear moves, transitions, blending, and a homing cycle.

10.10.7.3.2 Motion Pattern Procedure

1. Download and start the application.
2. Press the **Enable** button to enable the axes and the axes group.
3. After the **Ready** light is on:
 - If working with the 3-Axis Demonstration machine, press the **Home** button to reference the axes and move them to their home position.
 - If working with other hardware, press the **Sim Mode** button.
4. After the **Ready** and **Homed** lights are on, turn the **Cycle Start** switch to 1. The axes begin moving in the programmed pattern.

10.10.7.3.3 Control Panel

Image #	Description	GUI
1	Used to change the coordinated motion feedrate from 0% to 200%.	
2	Displays the axis positions.	
3	Ready indicator light. Ready indicates: <ul style="list-style-type: none"> • Ready indicates: <ul style="list-style-type: none"> • The axes are enabled. • The axes group is ready and enabled for coordinated motion. 	
4	Homed indicator light. Homed indicates: <ul style="list-style-type: none"> • Each axis has been referenced. • The axis group has moved to its zero position. 	
5	Simulation Mode indicator light. Sim Mode indicates: <ul style="list-style-type: none"> • The homing functions have been bypassed. • The program is set up as if the homing function has been performed. 	
6	Begins the coordinated motion pattern. Ready and Homed lights must both be on to execute motion.	
7	Causes an Emergency Stop for all axes. <ul style="list-style-type: none"> • The axes are disabled. • Ready and Homed lights are turned off. 	
8	<ul style="list-style-type: none"> • Resets the Emergency Stop. • Clears axis errors. 	
9	Disables the axes or axes group. The axes must be at a standstill to disable the group.	
10	Enables the axes and the axes group. This turns on the Ready light.	
11	Starts a homing function. <ul style="list-style-type: none"> • Each axis is referenced. • Moves all axes or axes group to their zero position. • Homing must be completed before executing a cycle start. • When homing is complete, the Homed light is turned on. 	
12	Sim Mode bypasses the homing function. This mode can be used when running on a simulator or when the hardware reference switches are not available. <ul style="list-style-type: none"> • The current position of each axis is set to zero position. • The homing function is not performed. • The Sim Mode light and Homed light are turned on. 	

10.10.8 Pipe Network Axis Templates

- "Pipe Network 1-Axis Template - FFLD" (→ p. 641)
- "Pipe Network 1-Axis Template - ST" (→ p. 641)
- "Pipe Network 2-Axes Template - FFLD" (→ p. 650)
- "Pipe Network 2-Axes Template - ST" (→ p. 647)
- "Pipe Network 2-Axes Template - FBD, FFLD, SFC, and ST" (→ p. 642)

10.10.8.1 Pipe Network 1-Axis Template - FFLD

The 1-axis Pipe Network template has an FFLD program (called **Main**) that initializes, starts and runs the motion.

There are controls to enable / disable the drive, clear faults, and display fault and axis position information in the Control Panel.

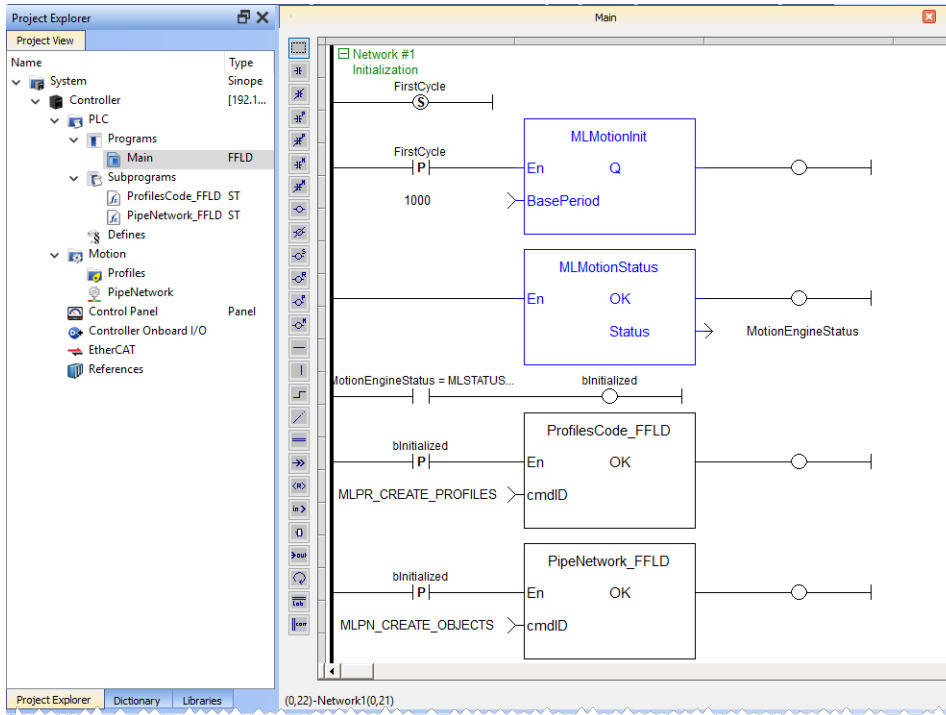
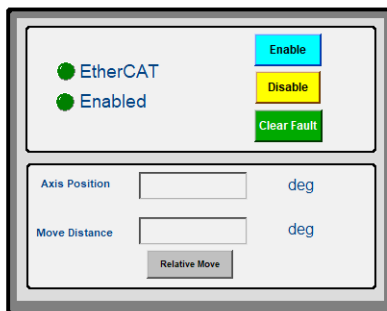

Figure 11-29: PN Template with FFLD - Main

Kollmorgen Automation Suite

Control Panel



10.10.8.2 Pipe Network 1-Axis Template - ST

The 1-axis Pipe Network template has a ST program (called **Main**) that initializes, starts and runs the motion.

Controls are included to enable/disable the drive, clear faults, and display fault and axis position information in the Control Panel.

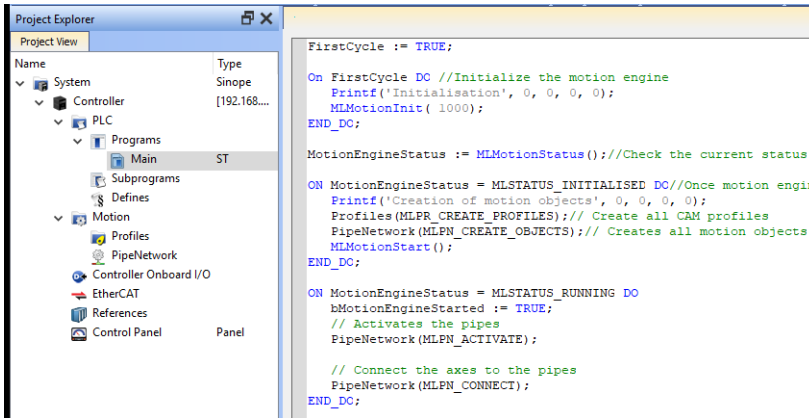
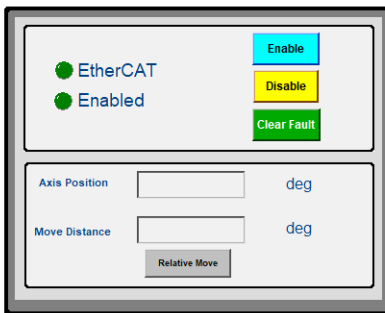

Figure 11-30: PN Template with ST - Main

Kollmorgen Automation Suite

Control Panel



10.10.8.3 Pipe Network 2-Axes Template - FBD, FFLD, SFC, and ST

Based on the template, the project can be run using either the:

- "KAS Simulator Graphical User Interface" (→ p. 365).
- Actual drives and motors.
 - In this case, set up the axes first in the EtherCAT part). See "Configuring EtherCAT" (→ p. 322) for more information.
- "Control Panel" (→ p. 642)
- "HMI" (→ p. 643)
- "Motion" (→ p. 644)
- "PLC Programs" (→ p. 644)

10.10.8.3.1 Control Panel

See "Design the HMI with the Internal Editor" (→ p. 464) for more information.

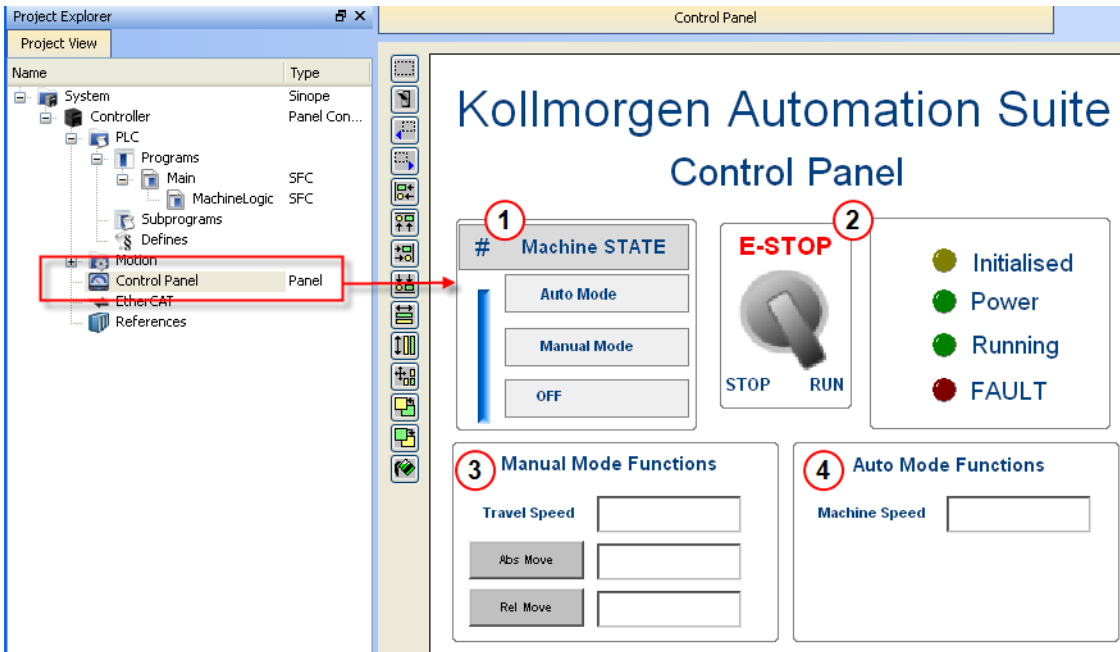

Figure 11-31: PN Template - Control Panel

Call Out#	Description
1	Used to choose how to run the axes between manual (3) and automatic (4) modes.
2	When you click the emergency button: <ul style="list-style-type: none"> The machine state becomes OFF (see call out 1). The two axes stop running.
3	In manual mode, you can set the speed. You can set an absolute and relative move. When you click those commands, the two axes move to the specified position and the speed is reset to 0 (zero).
4	In automatic mode, you can set the speed.

10.10.8.3.2 HMI

In the project template is an HMI screen for the AKI terminals created in the Kollmorgen Visualization Builder (KVB) environment.

The KVB software is a separate installation from the KAS-IDE. KVB can be opened from within KAS-IDE by double-clicking on the **KVB Project** item in the project tree.

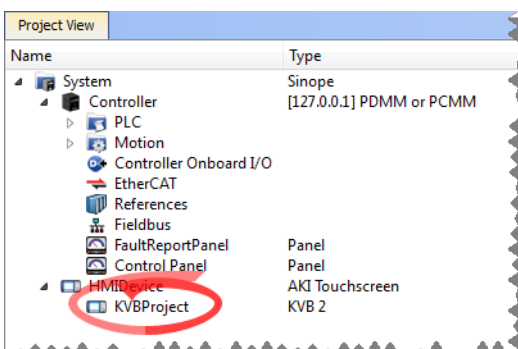

The project can be run in the KVB programming environment after the KAS-IDE program has started running. Click the Run button in the Project ribbon to start the program.

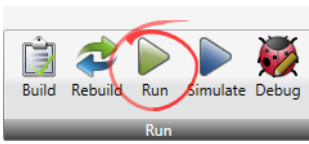

A screen duplicates the controls on the IDE Internal Control panel screen. An English or German screen is available.

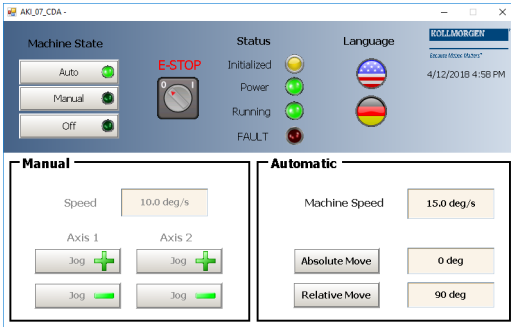

10.10.8.3.3 Motion

The template has a motion profile defined with the graphical Pipe Network editor.

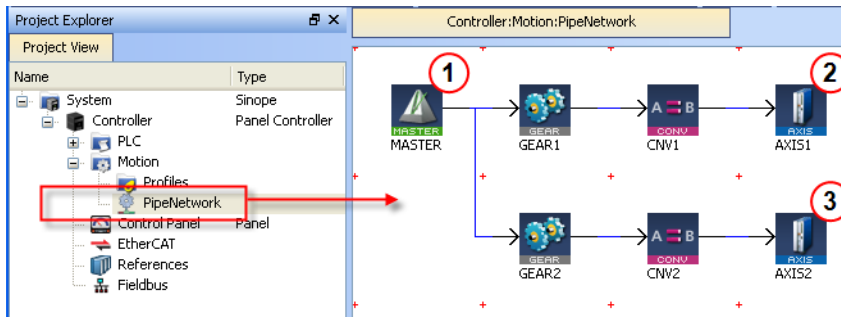

Figure 11-32: PN Template - Motion

The motion profile contains these different pipe blocks:

- The **Master** (see call out 1) is the generator that allows a synchronization between the two pipes (2) and (3).
- The **Gear** modifies (with ratio and offset) the flow of values issued from the Master.
- The **Converter** controls the position of the axis.
- The **Axis** gives access to the physical remote drive.

10.10.8.3.4 PLC Programs

The 2-axes Pipe Network template has an SFC program (called **Main**) that initializes and starts the motion.

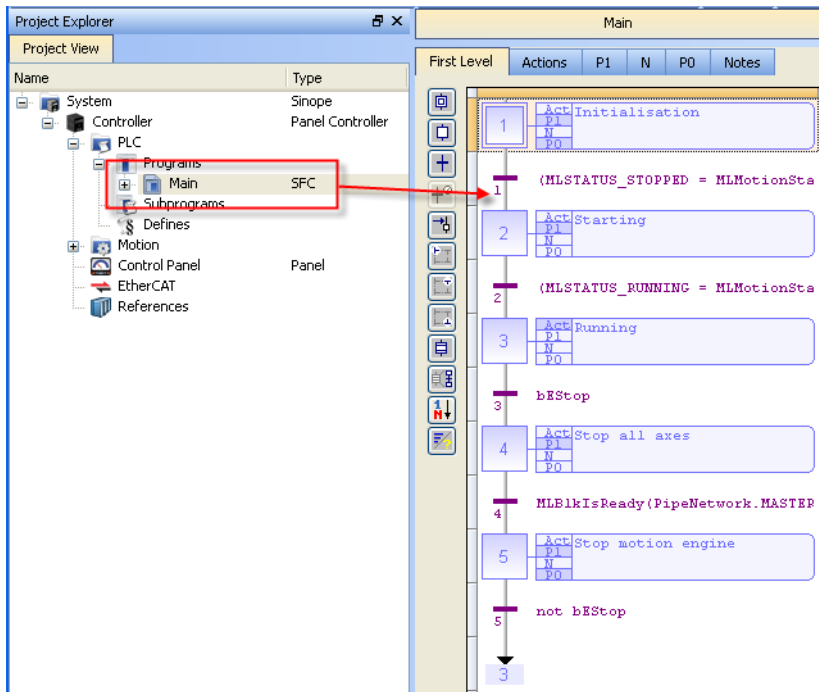

Figure 11-33: PN Template - Main

The Pipe Network Template contains an SFC child program called Machine Logic for running motion.

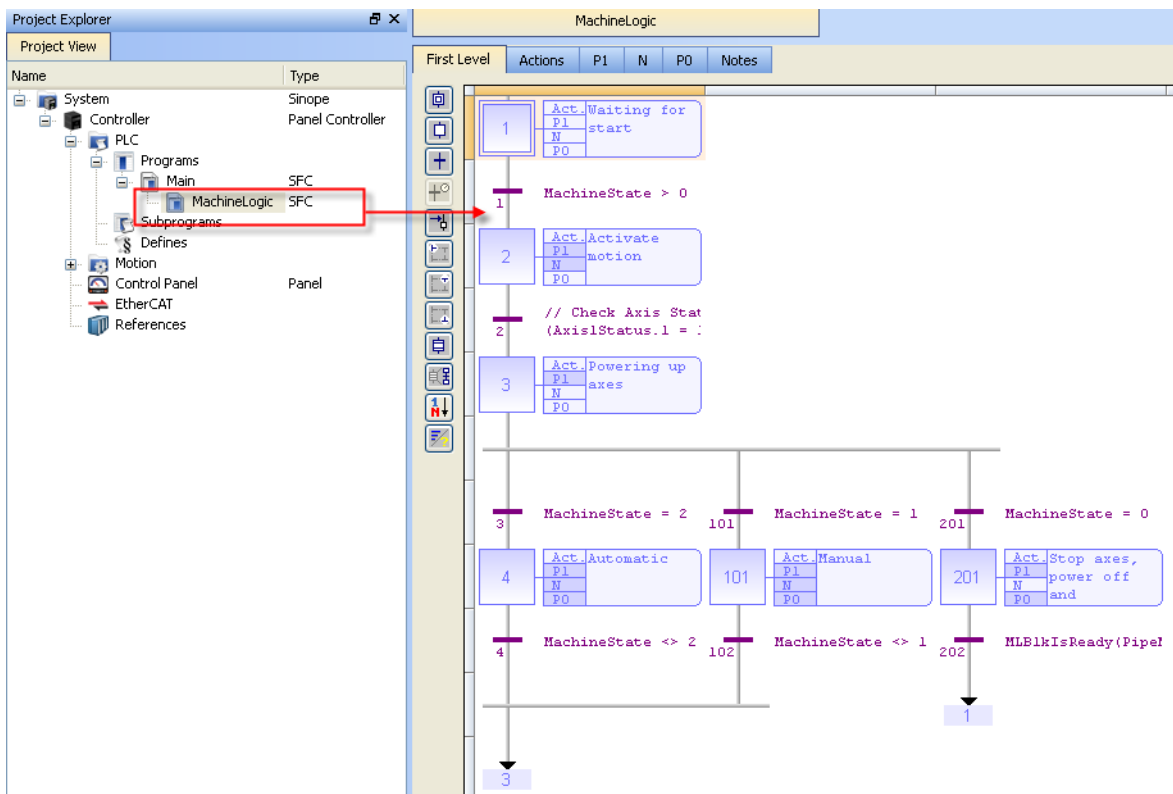
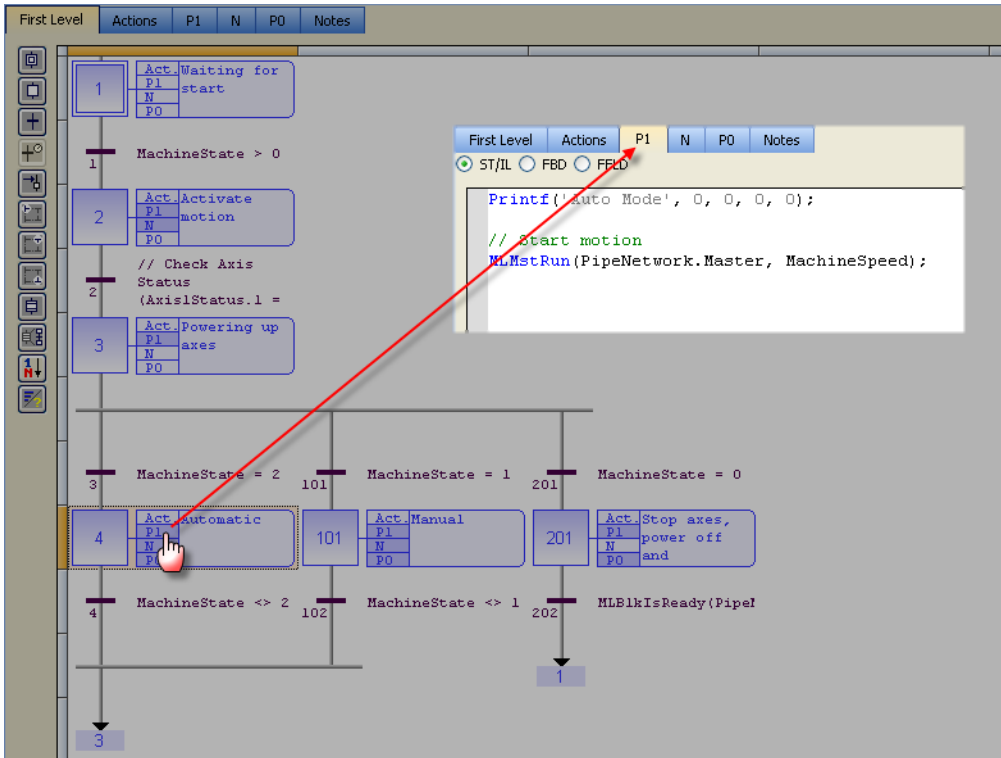
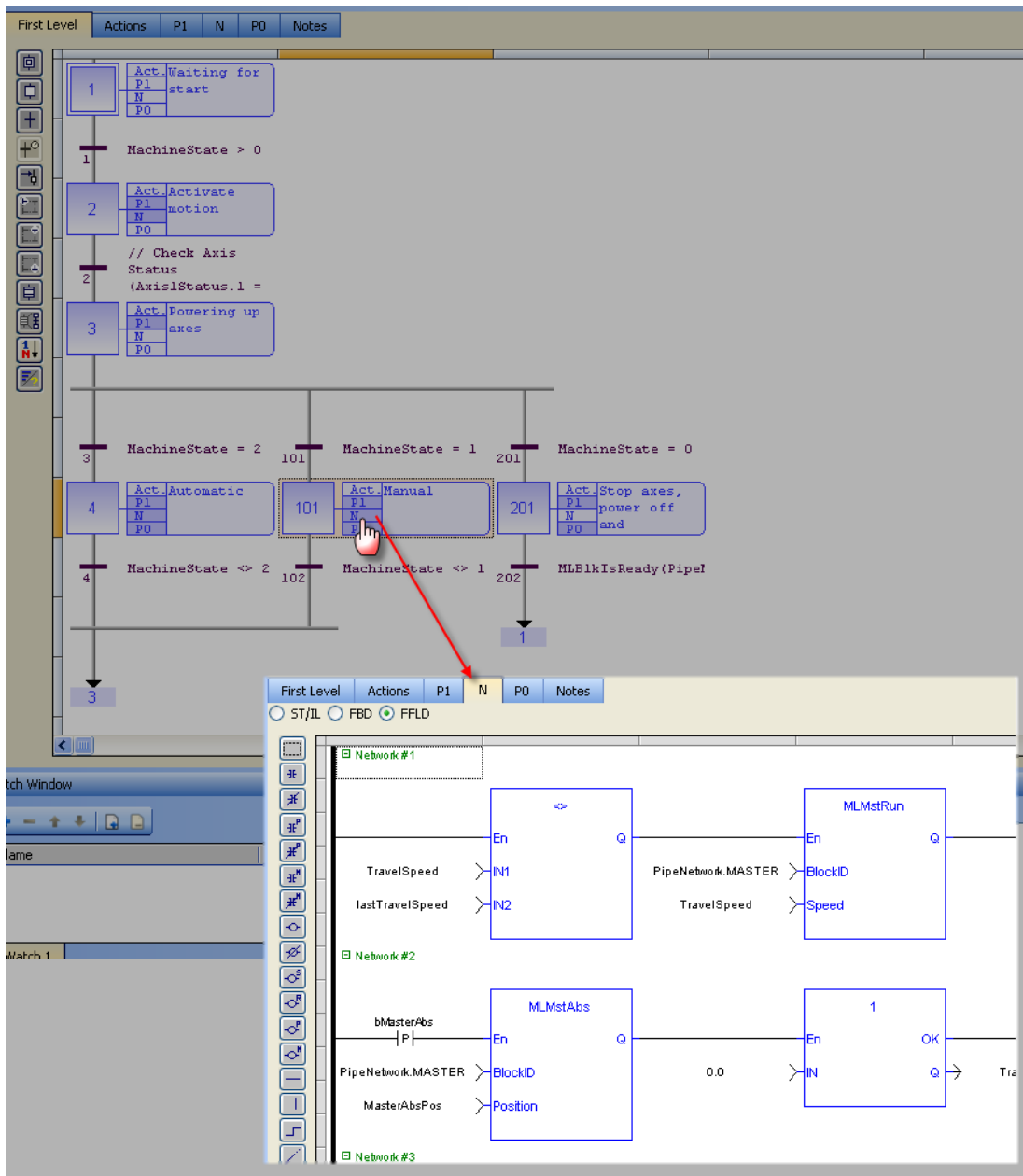

Figure 11-34: PN Template - MachineLogic

ST programs are found in the P1 and P0 actions for many steps



FFLD programs are found in the N action for steps 4 and 101



10.10.8.4 Pipe Network 2-Axes Template - ST

Based on the template, the project can be run using either the:

- "KAS Simulator Graphical User Interface" (→ p. 365).
- Actual drives and motors.
 - In this case, set up the axes first in the EtherCAT part). See "Configuring EtherCAT" (→ p. 322) for more information.

10.10.8.4.1 Control Panel

See "Design the HMI with the Internal Editor" (→ p. 464) for more information.

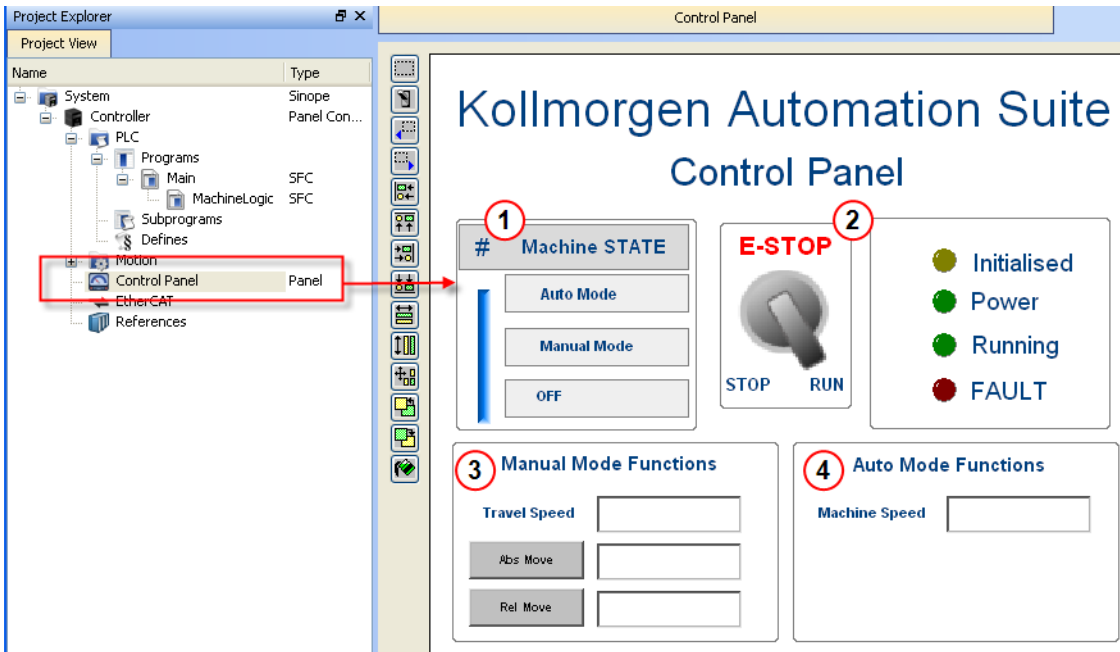

Figure 11-35: PN Template - Control Panel

Call Out#	Description
1	Used to choose how to run the axes between manual (3) and automatic (4) modes.
2	When you click the emergency button: <ul style="list-style-type: none"> The machine state becomes OFF (see call out 1). The two axes stop running.
3	In manual mode, you can set the speed. You can set an absolute and relative move. When you click those commands, the two axes move to the specified position and the speed is reset to 0 (zero).
4	In automatic mode, you can set the speed.

10.10.8.4.2 HMI

In the project template is an HMI screen for the AKI terminals created in the Kollmorgen Visualization Builder (KVB) environment.

The KVB software is a separate installation from the KAS-IDE. KVB can be opened from within KAS-IDE by double-clicking on the **KVB Project** item in the project tree.

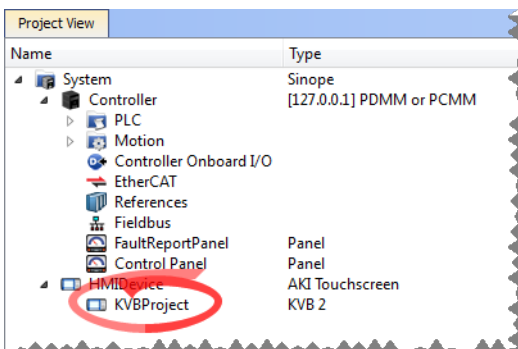

The project can be run in the KVB programming environment after the KAS-IDE program has started running. Click the Run button in the Project ribbon to start the program.

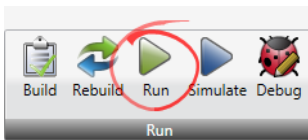

A screen duplicates the controls on the IDE Internal Control panel screen. An English or German screen is available.

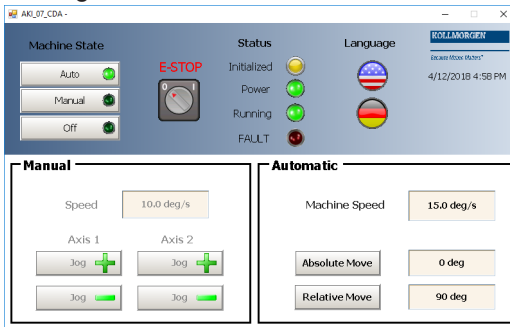

10.10.8.4.3 Motion

The template has a motion profile defined with the graphical Pipe Network editor.

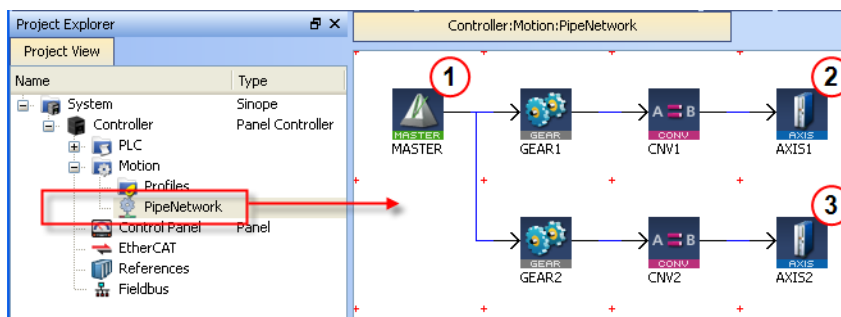

Figure 11-36: PN Template - Motion

The motion profile contains these different pipe blocks:

- The **Master** (see call out **1**) is the generator that allows a synchronization between the two pipes (**2**) and **3**).
- The **Gear** modifies (with ratio and offset) the flow of values issued from the Master.
- The **Converter** controls the position of the axis.
- The **Axis** gives access to the physical remote drive.

10.10.8.4.4 PLC Programs

The 2-axes Pipe Network template has a ST program (called **Main**) that initializes, starts and runs the motion.

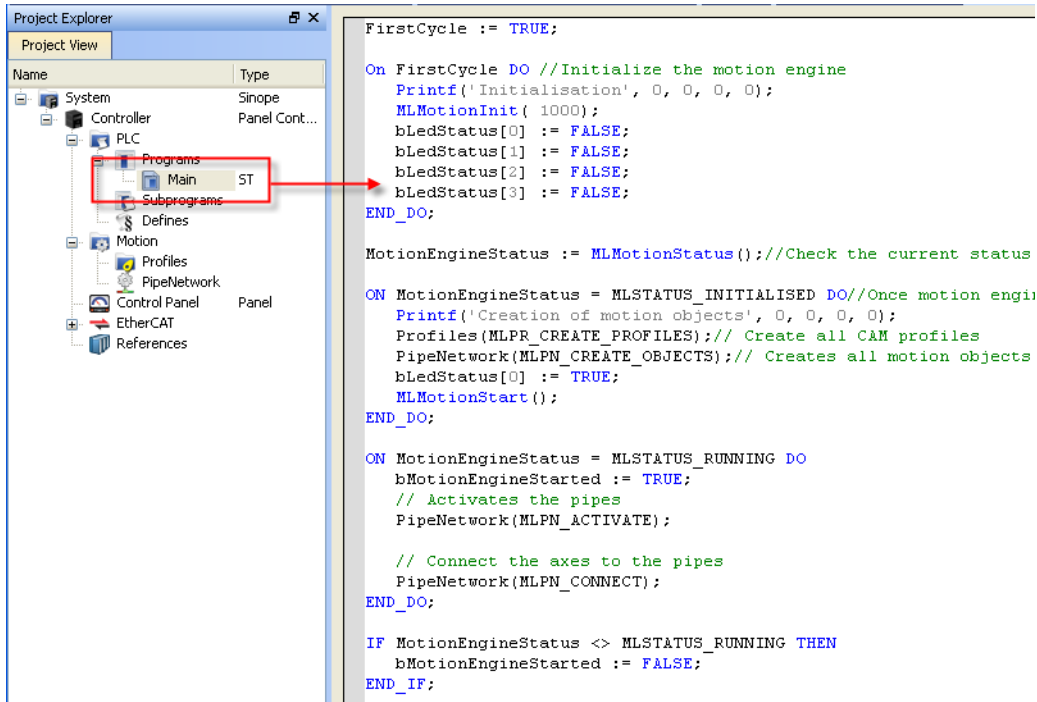

Figure 11-37: PN Template with ST - Main

10.10.8.5 Pipe Network 2-Axes Template - FFLD

Based on the template, the project can be run using either the:

- "KAS Simulator Graphical User Interface" (→ p. 365).
- Actual drives and motors.
 - In this case, set up the axes first in the EtherCAT part).
See "Configuring EtherCAT" (→ p. 322) for more information.
- "Control Panel" (→ p. 650)
- "HMI" (→ p. 651)
- "Motion" (→ p. 652)
- "PLC Programs" (→ p. 652)

10.10.8.5.1 Control Panel

See "Design the HMI with the Internal Editor" (→ p. 464) for more information.

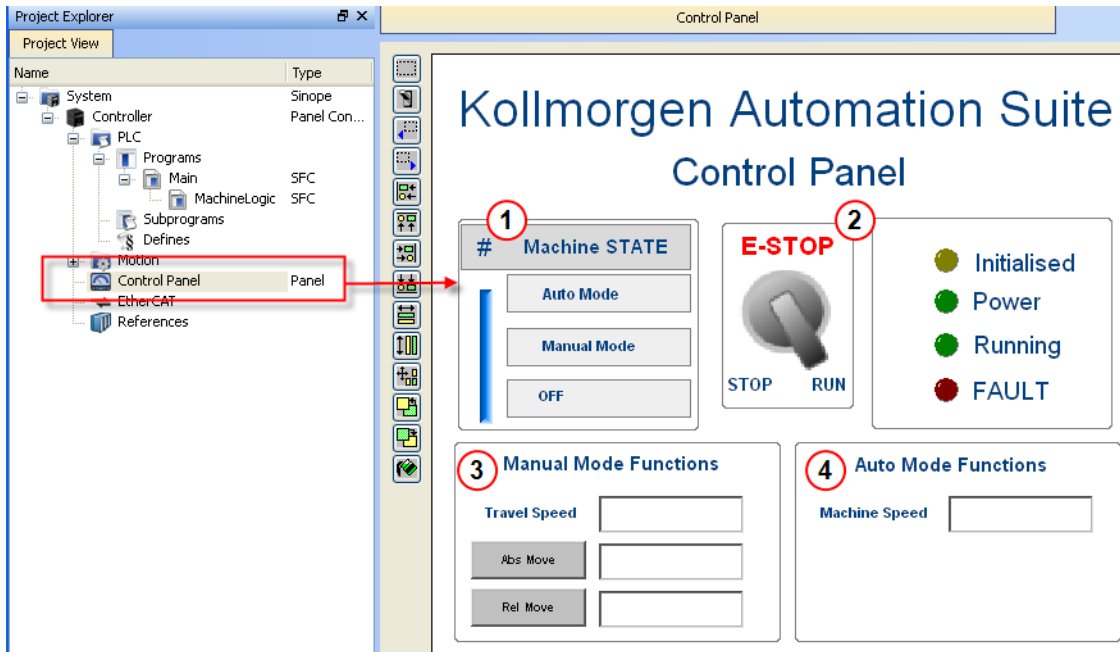

Figure 11-38: PN Template - Control Panel

Call Out#	Description
1	Used to choose how to run the axes between manual (3) and automatic (4) modes.
2	When you click the emergency button: <ul style="list-style-type: none"> The machine state becomes OFF (see call out 1). The two axes stop running.
3	In manual mode, you can set the speed. You can set an absolute and relative move. When you click those commands, the two axes move to the specified position and the speed is reset to 0 (zero).
4	In automatic mode, you can set the speed.

10.10.8.5.2 HMI

In the project template is an HMI screen for the AKI terminals created in the Kollmorgen Visualization Builder (KVB) environment.

The KVB software is a separate installation from the KAS-IDE. KVB can be opened from within KAS-IDE by double-clicking on the **KVB Project** item in the project tree.

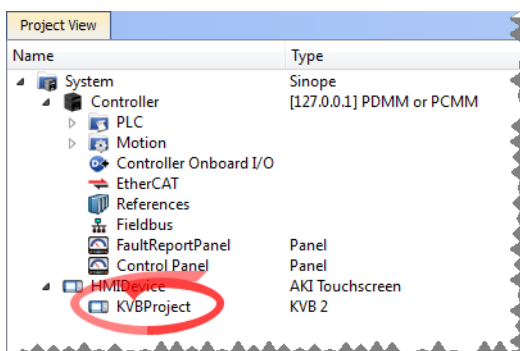

The project can be run in the KVB programming environment after the KAS-IDE program has started running. Click the Run button in the Project ribbon to start the program.

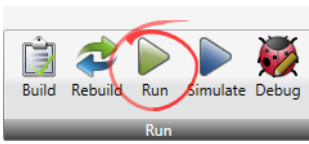

A screen duplicates the controls on the IDE Internal Control panel screen. An English or German screen is available.

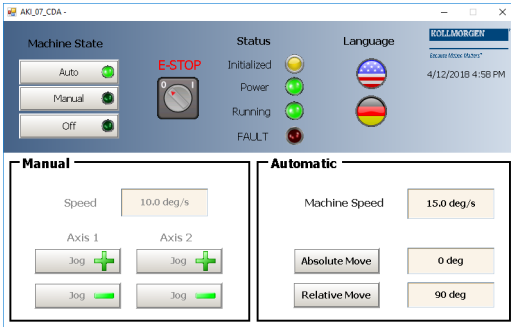

10.10.8.5.3 Motion

The template has a motion profile defined with the graphical Pipe Network editor.

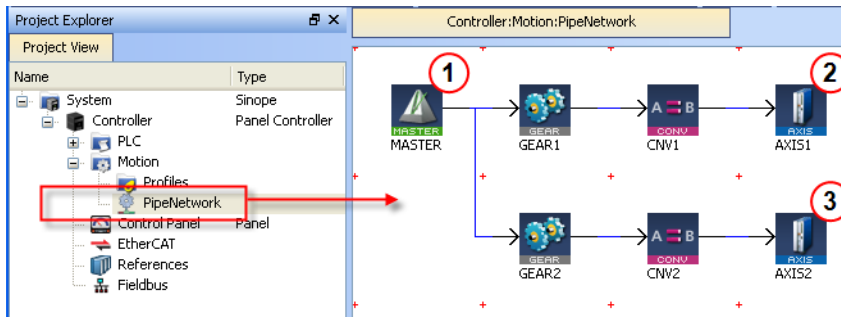

Figure 11-39: PN Template - Motion

The motion profile contains these different pipe blocks:

- The **Master** (see call out 1) is the generator that allows a synchronization between the two pipes (2) and (3).
- The **Gear** modifies (with ratio and offset) the flow of values issued from the Master.
- The **Converter** controls the position of the axis.
- The **Axis** gives access to the physical remote drive.

10.10.8.5.4 PLC Programs

The 2-axes Pipe Network template has a FFLD program (called **Main**) that initializes, starts and runs the motion.

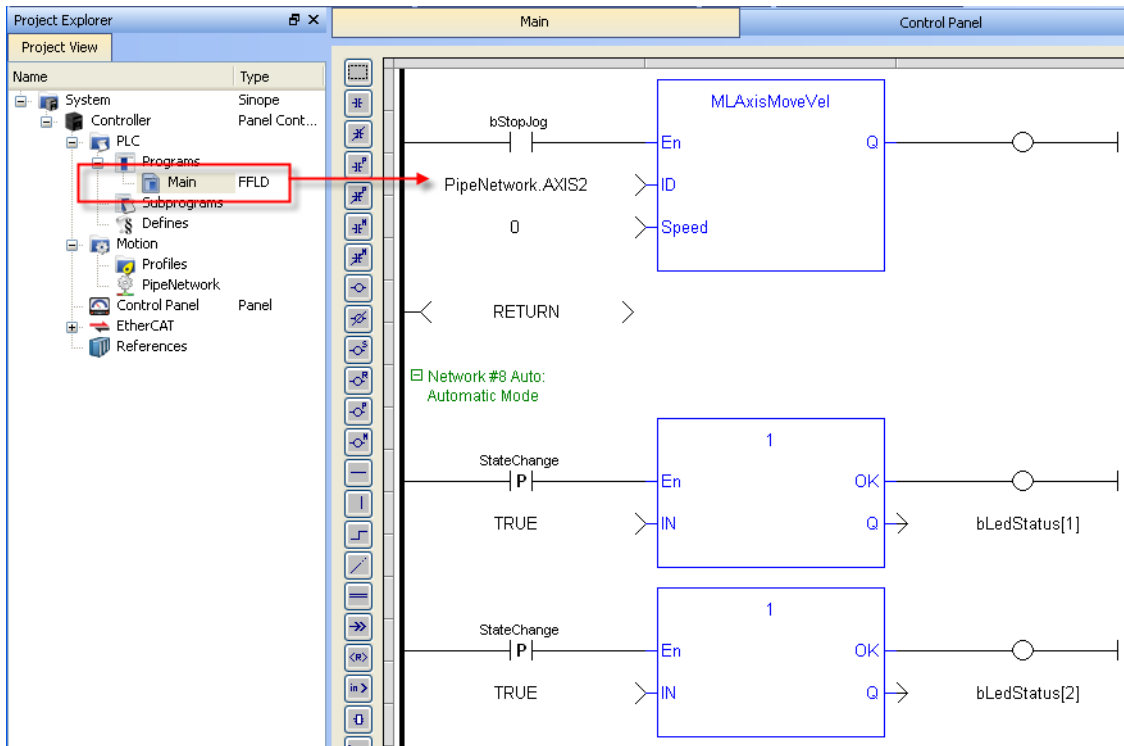

Figure 11-40: PN Template with FFLD - Main

10.10.9 PLCopen Axis Templates

- "PLCopen 1-Axis Template - FFLD" (→ p. 653)
- "PLCopen 1-Axis Template - ST" (→ p. 654)
- "PLCopen 2-Axes Template - FFLD" (→ p. 663)
- "PLCopen 2-Axes Template - ST" (→ p. 659)
- "PLCopen 2-Axes Template - FFLD and SFC" (→ p. 655)

10.10.9.1 PLCopen 1-Axis Template - FFLD

The 1-axis PLCopen template has an FFLD program (called **Main**) that initializes and starts the motion.

- Controls are included to enable/disable the drive, clear faults, and display fault and axis position information in the Control Panel.
- A second program, FaultMonitor, reads the drive fault and position information.
- The programs are commented to ease their use.

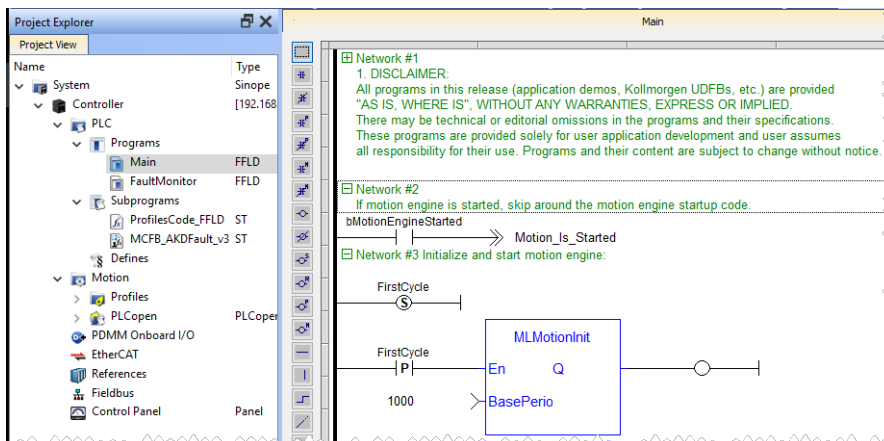
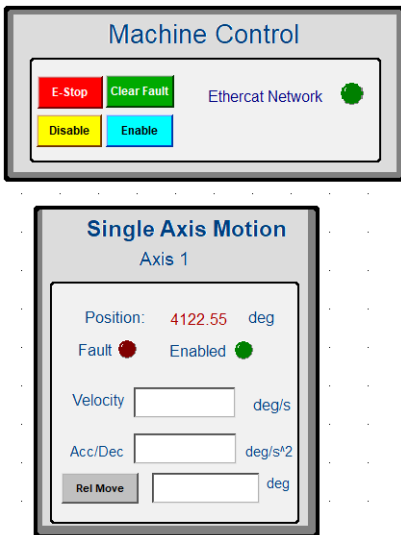

Figure 11-41: PLCopen Template with FFLD - Main



10.10.9.2 PLCopen 1-Axis Template - ST

This 1-axis PLCopen template has a ST program (called **Main**) that initializes, starts and runs the motion.

- Controls are included to enable/disable the drive, clear faults, and display fault and axis position information in the Control Panel.
- A subprogram reads the drive fault and position information.
- The programs are commented to ease their use.

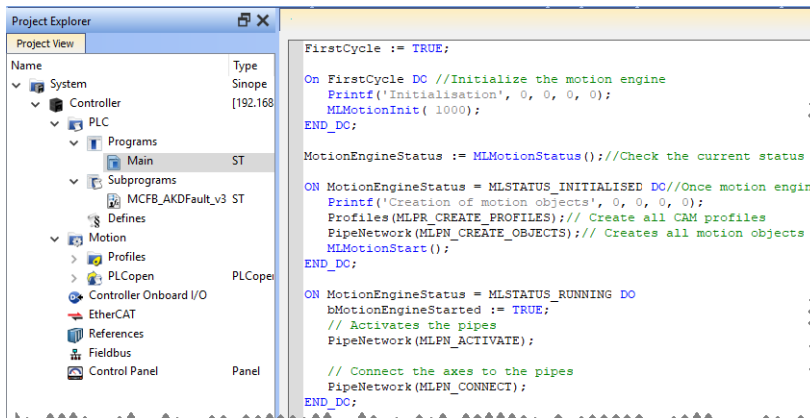
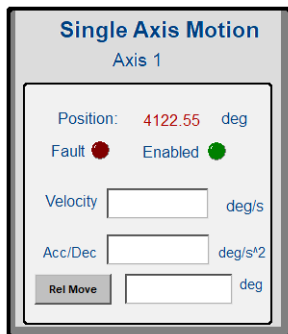
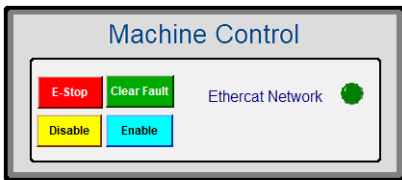

Figure 11-42: PLCopen Template with ST - Main



10.10.9.3 PLCopen 2-Axes Template - FFLD and SFC

This template project contains a two-axis template for getting started with a KAS application.

- It contains key project elements that save development time.
- The templates are designed to add code to the programs and Control Panels in the template or to new templates.
 - This template program can be run on the KAS Simulator or with an AKD PDMM or PCMM and AKD drives.
- A project can contain many programs, and each program can be written in FBD, FFLD, IL, SFC or ST programming languages.
- Additional axes can be added to the template applications that have three, four, five, or more axes.

This project contains two axes where Axis 2 is slaved to Axis 1 at a 2:1 ratio.

10.10.9.3.1 PLC Programs

The 2-axes PLCopen template has an SFC program (called **Main**) that initializes and starts the motion.

- The motion includes single axis jogging, incremental and absolute moves, and gearing motion between axes.
- Controls are included to enable/disable the drive, clear faults, and display fault and axis position information in the Control Panel.

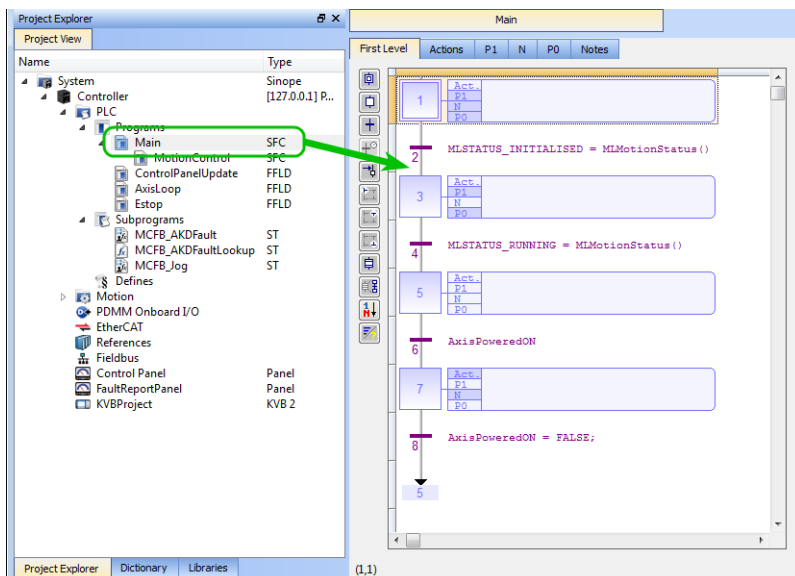

Figure 11-43: PLCopen - Template Main

Step 5 of the Main program in the PLCopen template contains the FFLD code for running the motion. As defined below with the MoveVelocity function block, the motion profile is based on a trapezoidal acceleration / deceleration.

See "S-curve and Trapezoidal Acceleration / Deceleration" (→ p. 771).

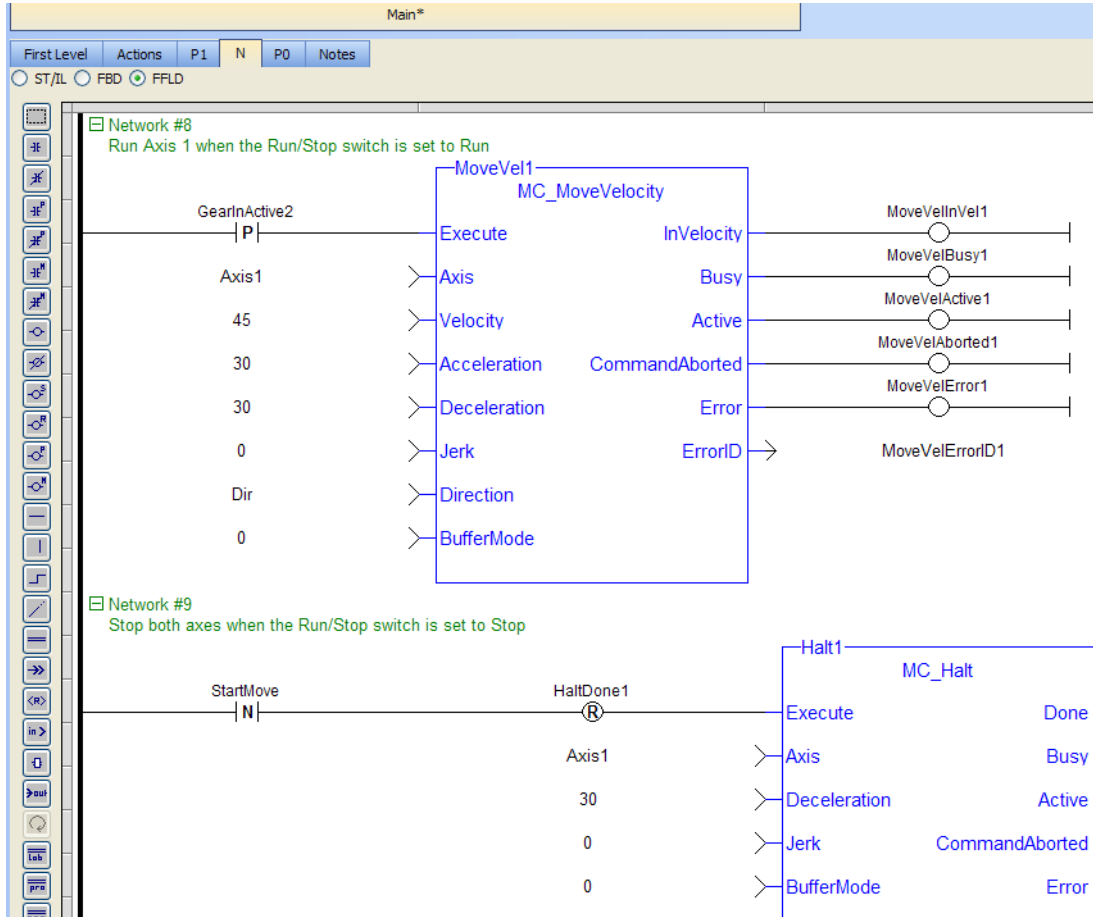

Figure 11-44: PLCopen Template - Step 5 of the Main

The template contains two PLCopen Servo axes where User Units, Update Rate, Rollover Position, and Axis Limits are defined as:

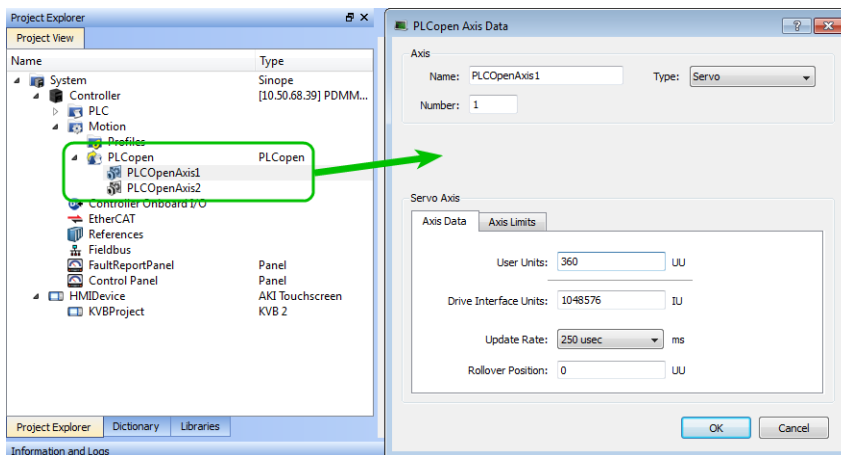

Figure 11-45: PLCopen Template - Motion

See "Axis Data Parameters" (→ p. 172) for more information about PLCopen axis parameters.

The template contains a Control Panel which works inside of the IDE when running a project. It is a useful tool to run and debug programs.

10.10.9.3.2.1 Control Panel Screens

The Control Panel has these screens:

- **Control Panel**
- **Fault Report Panel**

10.10.9.3.3.2 Control Panel Sections

The Control Panel has these sections:

- **Multi-Axis Commands:** Controls motion and shows gearing.
- **Single Axis Motion Commands:** Shows motion at the single axis level and resetting the axis position.
- **Axis Status:** Shows basic axis information.

See "Design the HMI with the Internal Editor" (→ p. 464) for more information.

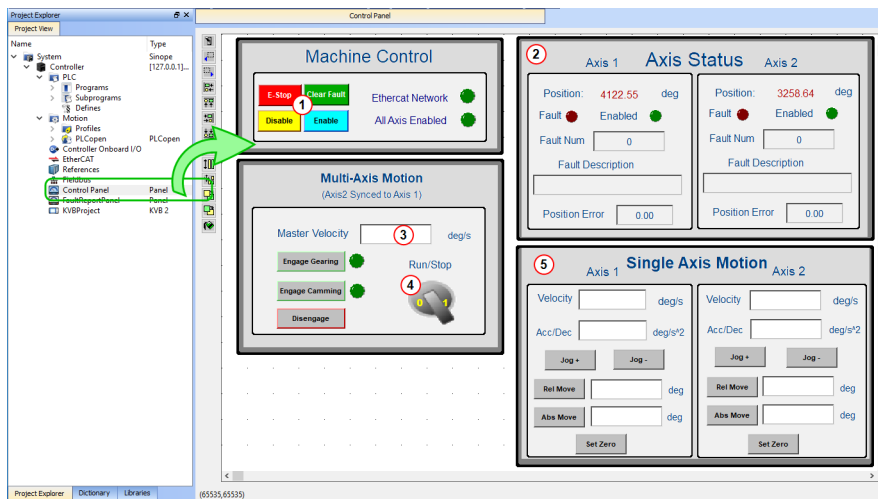

Figure 11-46: PLCopen Template - Control Panel

Call out#	Description
1	Allows for enabling or disabling the axes. After an emergency stop, select the Reset and Enable commands before running the axes.
2	Displays the actual position for each axis.
3	Used to set the speed.
4	Start or stop the motion on the condition that the axes are enable. The green light must be switched on.
5	Control the axis motion.

Fault Report Panel provides more detailed information about when a drive fault occurs.

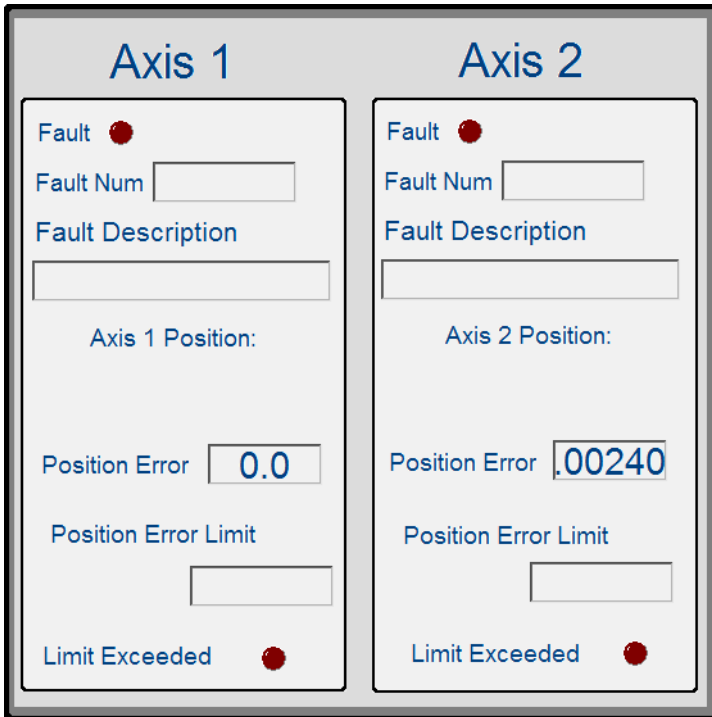

Figure 11-47: PLCopen Template - Fault Report Panel

Based on the template, the project can be run using either the:

- "KAS Simulator Graphical User Interface" (→ p. 365).
- Actual drives and motors.
 - In this case, set up the axes first in the EtherCAT part). See "Configuring EtherCAT" (→ p. 322) for more information.

Included in the project template are HMI screens for the AKI terminals created in the KVB (Kollmorgen Visualization Builder) environment.

- The KVB software is a separate installation from the KAS-IDE.
- In KAS-IDE, double-click the **KVB Project** item in the project tree to open KVB.

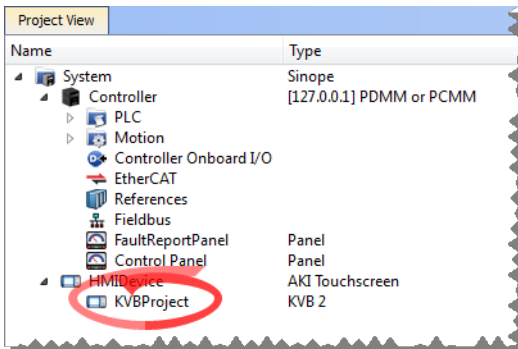

The project can be run in the KVB programming environment after the KAS-IDE program has started running.

Click on the Run button in the Project ribbon to start the program.

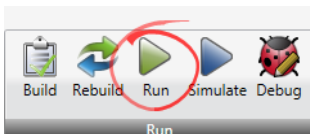

These screens, localized in English and German, are included that duplicate the controls on the IDE Internal Control panel screens.



Home Screen

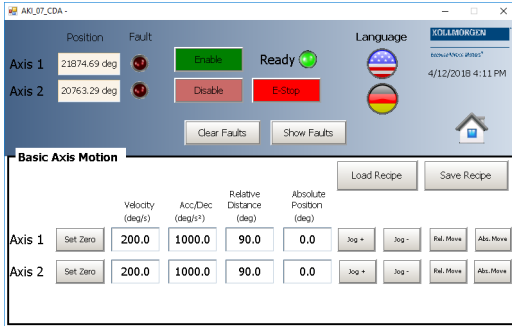

Basic Motion

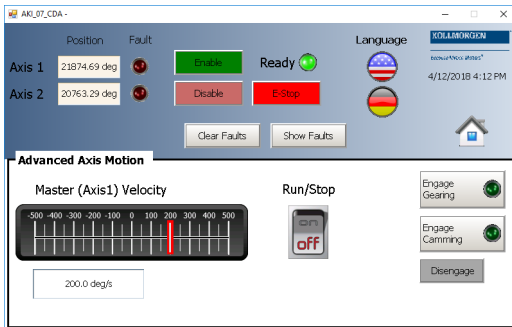

Advanced Motion

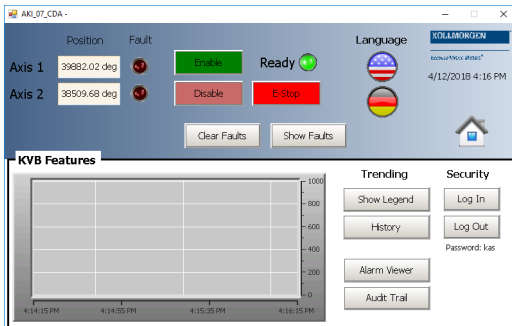

KVB Features

10.10.9.4 PLCopen 2-Axes Template - ST

This template project contains a two-axis template for getting started with a KAS application.

- It contains key project elements that save development time.
- The templates are designed to add code to the programs and Control Panels in the template or to new templates.
 - This template program can be run on the KAS Simulator or with an AKD PDMM or PCMM and AKD drives.
- A project can contain many programs, and each program can be written in FBD, FFLD, IL, SFC or ST programming languages.
- Additional axes can be added to the template applications that have three, four, five, or more axes.

10.10.9.4.1 PLC Programs

This 2-axis PLCopen template has a ST program (called **Main**) that initializes, starts and runs the motion. The motion includes single axis jogging, incremental and absolute moves, and gearing motion between axes. Also included are controls to enable/disable the drives, clear faults, and display fault and axis position information in the Control Panel. A second program, FaultMonitor, reads the drive fault and position information.

The programs are commented to ease their use.

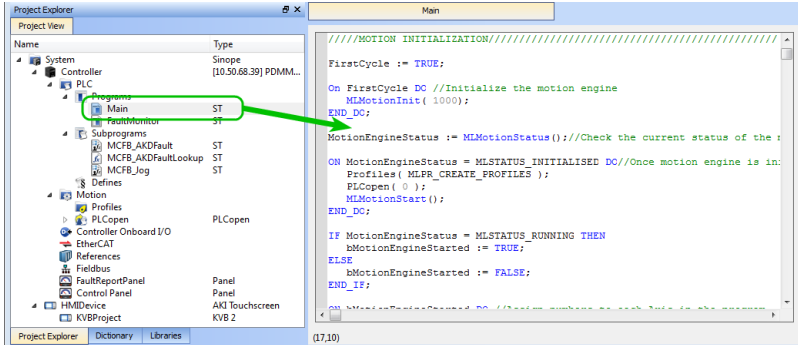

Figure 11-48: PLCopen Template with ST - Main

Also included are three subprograms (**MCFB_AKDFault**, **MCFB_AKDFaultLookup**, and **MCFB_Jog**) that are Kollmorgen UDFBs and can be found in the Project Library section of the IDE.

The template contains two PLCopen Servo axes where User Units, Update Rate, Rollover Position, and Axis Limits are defined as:

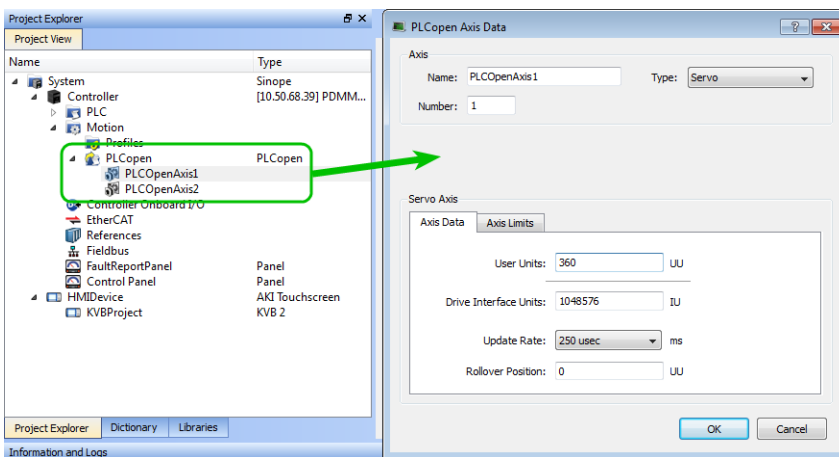

Figure 11-49: PLCopen Template - Motion

See "Axis Data Parameters" (→ p. 172) for more information about PLCopen axis parameters.

The template contains a Control Panel which works inside of the IDE when running a project.

It is a useful tool to run and debug programs.

10.10.9.4.2.1 Control Panel Screens

The Control Panel has these screens:

- **Control Panel**
- **Fault Report Panel**

10.10.9.4.3.2 Control Panel Sections

The Control Panel has these sections:

- **Multi-Axis Commands:** Controls motion and shows gearing.
- **Single Axis Motion Commands:** Shows motion at the single axis level and resetting the axis position.
- **Axis Status:** Shows basic axis information.

See "Design the HMI with the Internal Editor" (→ p. 464) for more information.

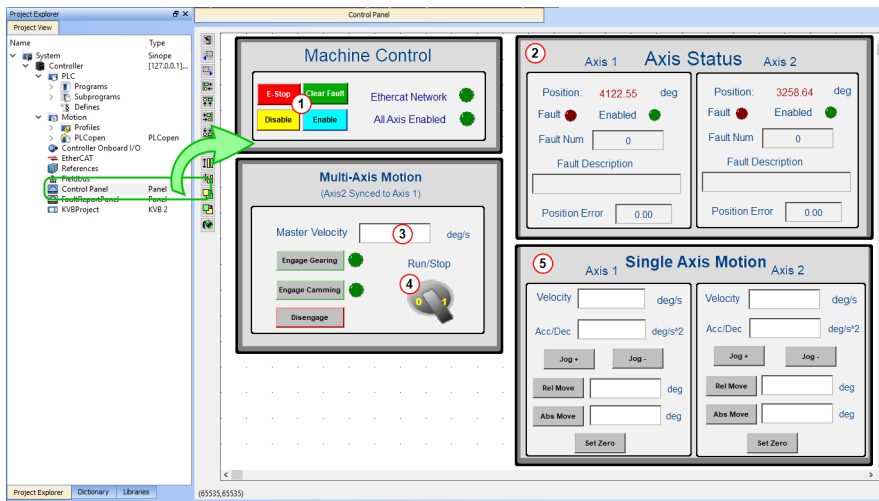

Figure 11-50: PLCopen Template - Control Panel

Call out#	Description
1	Allows for enabling or disabling the axes. After an emergency stop, select the Reset and Enable commands before running the axes.
2	Displays the actual position for each axis.
3	Used to set the speed.
4	Start or stop the motion on the condition that the axes are enable. The green light must be switched on.
5	Control the axis motion.

Fault Report Panel provides more detailed information about when a drive fault occurs.

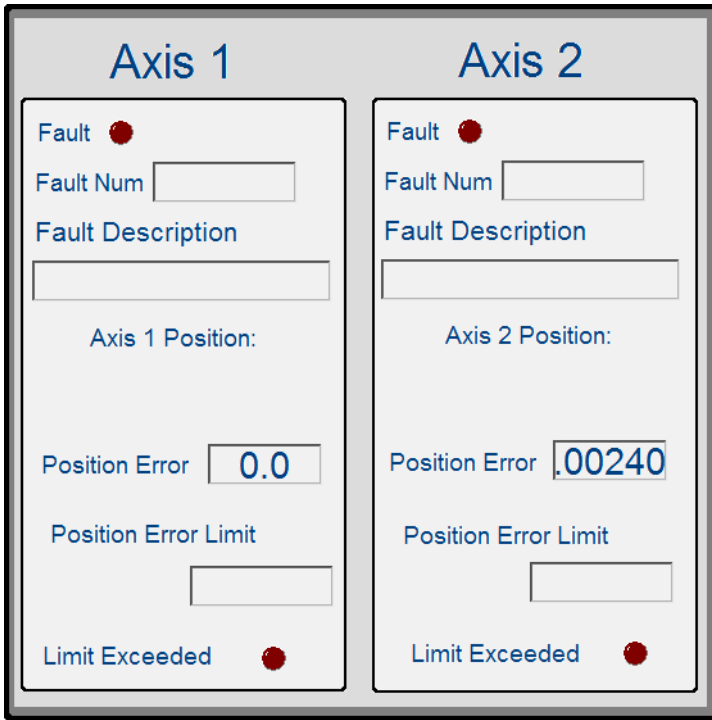
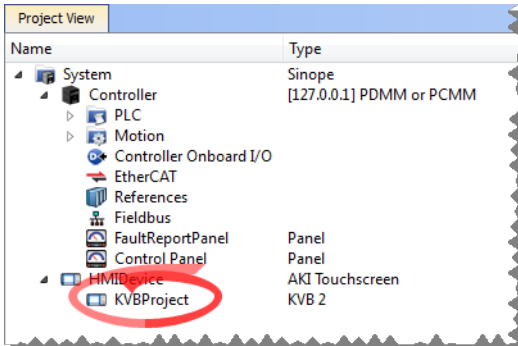

Figure 11-51: PLCopen Template - Fault Report Panel

Included in the project template are HMI screens for the AKI terminals created in the KVB (Kollmorgen Visualization Builder) environment.

- The KVB software is a separate installation from the KAS-IDE.
- In KAS-IDE, double-click the **KVB Project** item in the project tree to open KVB.



The project can be run in the KVB programming environment after the KAS-IDE program has started running. Click on the Run button in the Project ribbon to start the program.

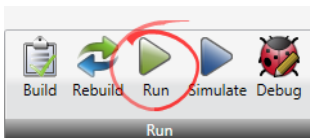

These screens, localized in English and German, are included that duplicate the controls on the IDE Internal Control panel screens.



Home Screen

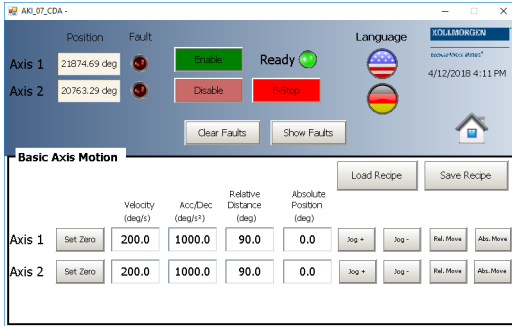

Basic Motion

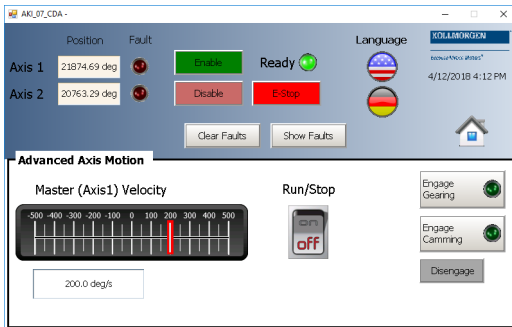

Advanced Motion

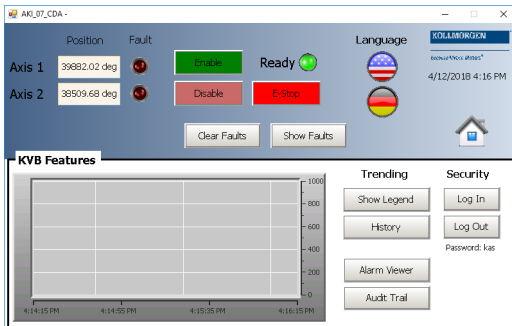

KVB Features

10.10.9.5 PLCopen 2-Axes Template - FFLD

This template project contains a two-axis template for getting started with a KAS application.

- It contains key project elements that save development time.
- The templates are designed to add code to the programs and Control Panels in the template or to new templates.
 - This template program can be run on the KAS Simulator or with an AKD PDMM or PCMM and AKD drives.
- A project can contain many programs, and each program can be written in FBD, FFLD, IL, SFC or ST programming languages.
- Additional axes can be added to the template applications that have three, four, five, or more axes.

This project contains two axes where Axis 2 is slaved to Axis 1 at a 2:1 ratio.

- "Control Panel" (→ p. 664)
- "HMI" (→ p. 665)
- "Motion" (→ p. 666)
- "PLC Programs" (→ p. 667)

10.10.9.5.1 Control Panel

The template contains a Control Panel which works inside of the IDE when running a project. It is a useful tool to run and debug programs.

10.10.9.5.2.1 Control Panel Screens

The Control Panel has these screens:

- **Control Panel**
- **Fault Report Panel**

10.10.9.5.3.2 Control Panel Sections

The Control Panel has these sections:

- **Multi-Axis Commands:** Controls motion and shows gearing.
- **Single Axis Motion Commands:** Shows motion at the single axis level and resetting the axis position.
- **Axis Status:** Shows basic axis information.

See "Design the HMI with the Internal Editor" (→ p. 464) for more information.

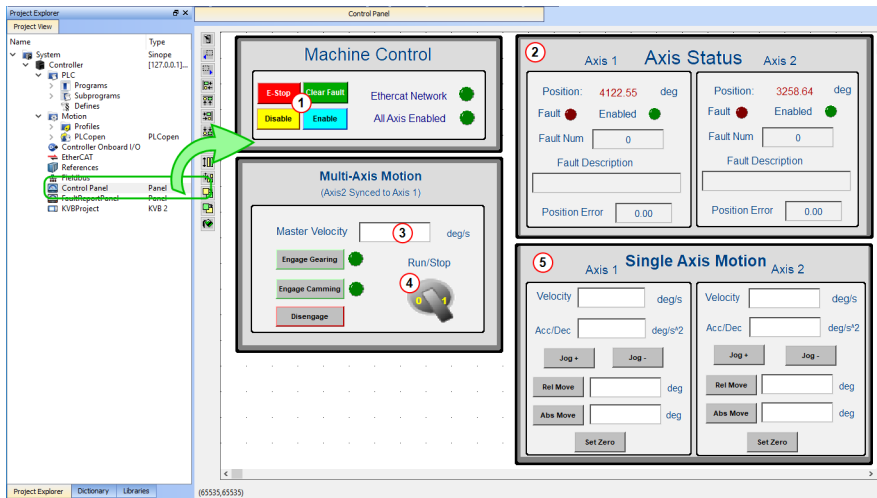

Figure 11-52: PLCopen Template - Control Panel

Call out#	Description
1	Allows for enabling or disabling the axes. After an emergency stop, select the Reset and Enable commands before running the axes.
2	Displays the actual position for each axis.
3	Used to set the speed.
4	Start or stop the motion on the condition that the axes are enable. The green light must be switched on.
5	Control the axis motion.

Fault Report Panel provides more detailed information about when a drive fault occurs.

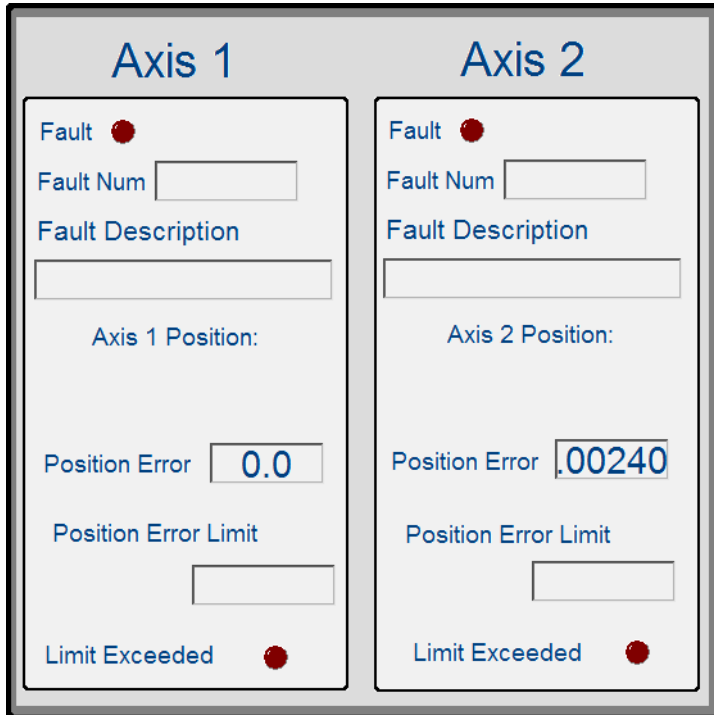
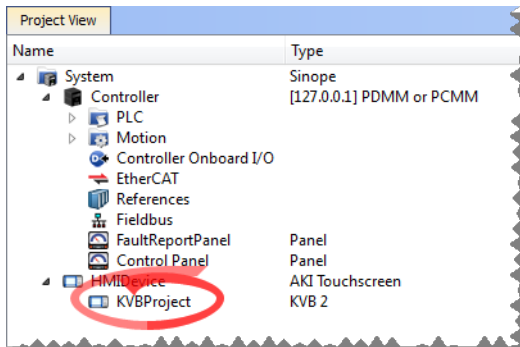

Figure 11-53: PLCopen Template - Fault Report Panel

10.10.9.5.4 HMI

Included in the project template are HMI screens for the AKI terminals created in the KVB (Kollmorgen Visualization Builder) environment.

- The KVB software is a separate installation from the KAS-IDE.
- In KAS-IDE, double-click the **KVB Project** item in the project tree to open KVB.



The project can be run in the KVB programming environment after the KAS-IDE program has started running. Click on the Run button in the Project ribbon to start the program.

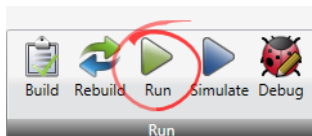

These screens, localized in English and German, are included that duplicate the controls on the IDE Internal Control panel screens.

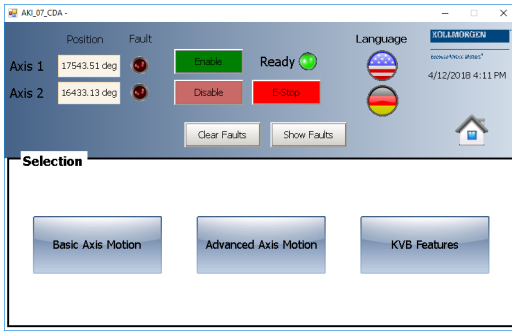

Home Screen

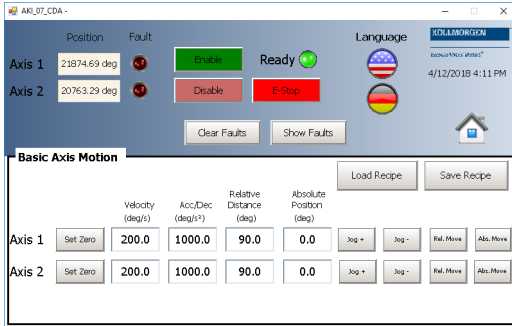

Basic Motion

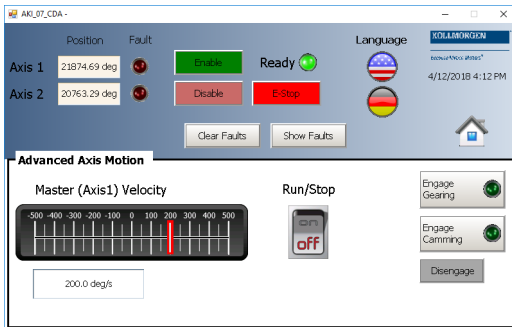

Advanced Motion

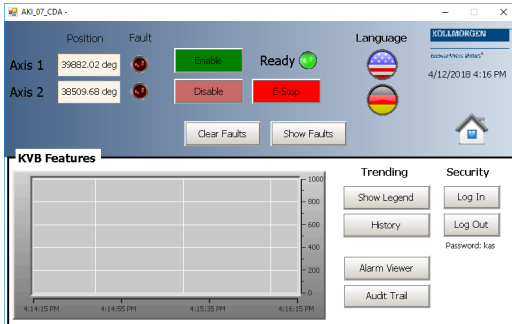

KVB Features

10.10.9.5.5 Motion

The template contains two PLCopen Servo axes where User Units, Update Rate, Rollover Position, and Axis Limits are defined as:

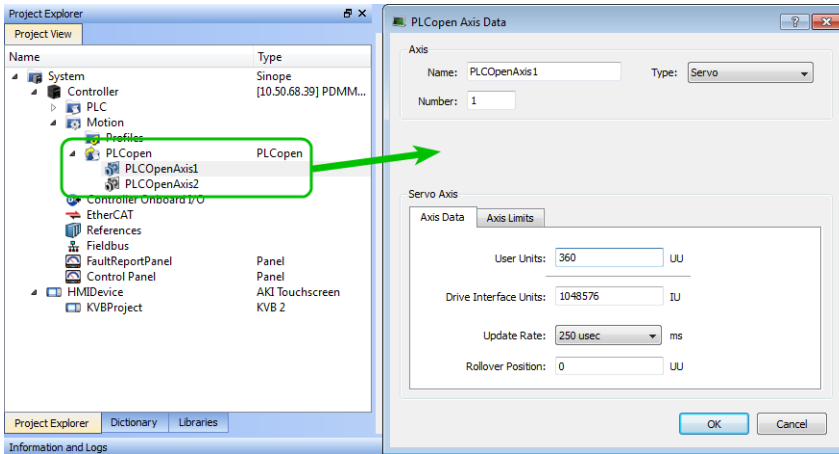

Figure 11-54: PLCopen Template - Motion

See "Axis Data Parameters" (→ p. 172) for more information about PLCopen axis parameters.

10.10.9.5.6 PLC Programs

The 2-axes PLCopen template has an FFLD program (called **Main**) that initializes and starts the motion.

- The motion includes:
 - Single axis jogging, incremental and absolute moves, and gearing motion between axes.
 - Controls to enable/disable the drives, clear faults, and display fault and axis position information in the Control Panel.

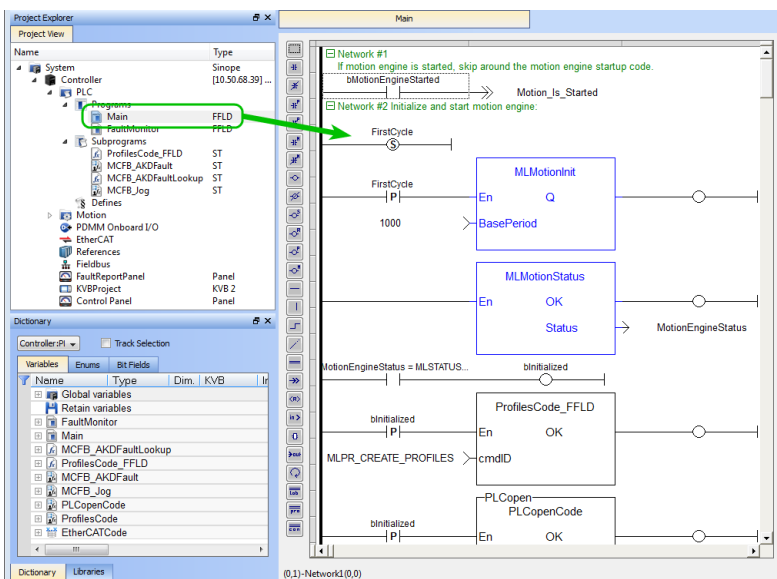

Figure 11-55: PLCopen Template with FFLD - Main

11 Controller Error and Alarm Descriptions

When either Errors or Alarms occur, always check the controller log messages.

- The controller continuously displays any error or alarm codes after booting and not in recovery mode.
- Errors have a priority over Alarms.
 - Only one error or alarm code is displayed at a time.
 - The code with the highest priority is displayed until it is cleared.
- The log messages provide more details about the failure and the history of events leading up to the failure.
 - Use the log messages to determine the specifics about the cause of the failure and correct the underlying problem.

11.1 Errors

Code	Description	Cause	Remedy	How to Clear**
** In the How to Clear column: An HW requires a reboot to clear the error or alarm. An SW error or alarm can be cleared from the web server.				
E01	AKD PDMM and PCMM: <ul style="list-style-type: none"> • After 20 seconds, the controller operation is stopped. • The CPU is put to sleep. • Critical temperature reached. <ul style="list-style-type: none"> • Critical temperature limit is 127 °C. PCMM2G: <ul style="list-style-type: none"> • After 20 seconds, the PLC application is stopped. • The CPU is throttled. • Critical temperature reached. <ul style="list-style-type: none"> • Critical temperature limit is 83 °C. 	Controller temperature exceeds the safe operating temperature limit.	<ul style="list-style-type: none"> • Power-off. • Check airflow and operating environment are within hardware specifications. • Allow unit to cool before power-on. 	<ul style="list-style-type: none"> • HW: <ul style="list-style-type: none"> • AKD PDMM and PCMM • SW: <ul style="list-style-type: none"> • PCMM2G

Code	Description	Cause	Remedy	How to Clear**
** In the How to Clear column: An HW requires a reboot to clear the error or alarm. An SW error or alarm can be cleared from the web server.				
E02	Out of memory. KAS Runtime is stopping.	Memory leak, memory corrupted, or hardware memory failure.	<ul style="list-style-type: none"> • Power-off/on. • If the problem is recurrent, check the Release Notes for firmware updates. • If the problem persists, return the hardware for repair. 	HW
E03	Fan failure.	CPU cooling fan is not able to operate properly.	<ul style="list-style-type: none"> • Check temperature and monitor for High temp alarm (see A01). • Return the hardware for fan replacement. 	<ul style="list-style-type: none"> • HW: <ul style="list-style-type: none"> • AKD PDMM and PCMM • SW: <ul style="list-style-type: none"> • PCMM2G
E10	Firmware is corrupted.	Flash memory corrupted during firmware download or flash hardware failure.	<ul style="list-style-type: none"> • Re-download firmware. • Boot into recovery mode, download firmware, and power-off/on. See "Recover Using the Web server" (→ p. 428) for more information. • If the problem persists, return the hardware for repair. 	SW
E11	AKD PDMM and PCMM only. Flash is corrupted, no file system is available.	AKD PDMM and PCMM only. At startup, the file system could not be mounted on the flash.	AKD PDMM and PCMM only. <ul style="list-style-type: none"> • Reset to factory defaults. • If the problem persists, return the hardware for repair. 	SW: AKD PDMM and PCMM only.
E12	Not enough flash memory available.	Flash memory is full, unable to write to flash.	Clean-up the flash memory by removing log files, application programs, recipes, or other data files.	SW

Code	Description	Cause	Remedy	How to Clear**
** In the How to Clear column: An HW requires a reboot to clear the error or alarm. An SW error or alarm can be cleared from the web server.				
E13	Out of NVRAM space to "Retain Variables" (→ p. 707).	NVRAM is full.	Change application to reduce the amount of retained variables.	SW
E14	AKD PDMM and PCMM only. Reset to factory defaults failed.	AKD PDMM and PCMM only. Flash memory could not be formatted during a Reset to Factory Defaults procedure.	AKD PDMM and PCMM only. <ul style="list-style-type: none"> Reset to factory defaults again from power-on. If the problem persists, return the hardware for repair. 	SW: AKD PDMM and PCMM only.
E15	Cannot read/write files from/to an SD card / USB flash drive.	<ul style="list-style-type: none"> PLC function failures do not cause this error. SD card / USB flash drive is not plugged in. The file system is corrupt and cannot be mounted. 	AKD PDMM and PCMM <ol style="list-style-type: none"> Insert a valid SD card. Reformat the SD card using the Settings > SD Card > Format button. PCMM2G <ol style="list-style-type: none"> Plug-in a valid USB flash drive. Reformat the USB flash drive using the Settings > USB Flash Drive > Format button. 	SW

Code	Description	Cause	Remedy	How to Clear**
** In the How to Clear column: An HW requires a reboot to clear the error or alarm. An SW error or alarm can be cleared from the web server.				
E16	Not enough space available on the SD card / USB flash drive.	<ul style="list-style-type: none"> SD card / USB flash drive is full, unable to write to the SD card / USB flash drive. PLC function failures. 	AKD PDMM and PCMM <ul style="list-style-type: none"> Clean-up the SD card space by deleting files. Reformat the SD card using the Settings > SD Card > Format button. PCMM2G <ul style="list-style-type: none"> Clean-up the USB flash drive space by deleting files. Reformat the USB flash drive using the Settings > USB Flash Drive > Format button. 	SW
E17	Cannot connect to a shared directory.	<ul style="list-style-type: none"> Improper shared directory configuration on remote computer or the controller. Improper permissions, access control, or security policy for computer's share configuration. Computer is not accessible via Ethernet network. 	<ul style="list-style-type: none"> Verify the computer's shared directory is accessible. Check and Apply the KAS Application > Shared Directory configuration. Power-off/on the controller. 	SW

Code	Description	Cause	Remedy	How to Clear**
** In the How to Clear column: An HW requires a reboot to clear the error or alarm. An SW error or alarm can be cleared from the web server.				
E20	Runtime plug-in, process, thread or application failed to start.	<ul style="list-style-type: none"> • KAS Runtime or application code failed to auto-start at boot. • Caused by either a high controller temperature at power up or a system error. 	<ol style="list-style-type: none"> 1. Check the web server for other alarms or errors (e.g., temperature alerts) and resolve them. 2. Power cycle the device. 3. If E20 is still reported, reset to factory defaults. 4. If the problem is recurrent, check the Release Notes for firmware updates. 5. Download firmware. 	HW
E21	Runtime process, thread, or driver failed to respond during operation.	<p>KAS Runtime code failed during normal operation.</p> <p>In extreme cases, the display may indicate that the controller failed at an early stage of the "Boot Sequence" (→ p. 377).</p>	<ul style="list-style-type: none"> • Power-off/on. • If the problem is recurrent, check the Release Notes for firmware updates. 	HW
E22	Fatal error in PLC program, application stopped.	Virtual machine failed to execute an instruction.	<ul style="list-style-type: none"> • Check the PLC application code for programming errors that could cause a fatal execution error (e.g., divide by zero, array out of bound, etc.) • Check that the IDE and controller Runtime versions are compatible. • Re-compile the application, download, and re-start. 	SW

Code	Description	Cause	Remedy	How to Clear**
** In the How to Clear column: An HW requires a reboot to clear the error or alarm. An SW error or alarm can be cleared from the web server.				
E23	CPU is overloaded.	Either: <ul style="list-style-type: none"> • The motion engine did not complete. • The PLC program did not complete within the timeout period due to excessive CPU load. 	<ul style="list-style-type: none"> • Stop the application. • Power-off/on. • Reduce the sample rate, simplify the application, or reduce the application cycles and restart the application. • See "CPU Overload (E23)" (→ p. 682). 	SW

Code	Description	Cause	Remedy	How to Clear**
** In the How to Clear column: An HW requires a reboot to clear the error or alarm. An SW error or alarm can be cleared from the web server.				
E24	PLC application cannot be started	PLC application cannot be started because of an existing condition. Possible reasons: <ul style="list-style-type: none"> • Maintenance operation is in progress. • Controller is in "Online Configuration Mode" (→ p. 255). • AKD Restore failed. • The IDE version of the compiled PLC code and controller runtime version do not match. • Previous download failed. 	<ol style="list-style-type: none"> 1. Check the controller web-server home page for any maintenance operation in-progress. Wait for the operation to finish. 2. Connect to the controller with the IDE and disable "Online Configuration Mode" (→ p. 255). 3. Check the EtherCAT network topology by using the Scan network button in the web-server's Restore tab. Correct the physical topology and re-execute an AKD-x restore. 4. The IDE version (only major.minor.micro) should match with runtime version. To correct, install the correct version of IDE or Runtime. 5. Connect the IDE and download application. 	SW

Code	Description	Cause	Remedy	How to Clear**
** In the How to Clear column: An HW requires a reboot to clear the error or alarm. An SW error or alarm can be cleared from the web server.				
E30	EtherCAT communication failure during operational mode.	Network communication error. <ul style="list-style-type: none"> This is commonly caused by a loose or bad EtherCAT connection occurring after the network successfully starts up. See the IDE Controller log for more information. 	<ul style="list-style-type: none"> Read the AKD-x parameter ECAT.DIAG for more information on where in the EtherCAT network the issue may be occurring. <ul style="list-style-type: none"> See Debugging Intermittent EtherCAT Communication Issues on KDN for more information. Check the EtherCAT network wiring and devices state. Re-start the application. 	SW
E31	EtherCAT communication failure during pre-op mode.	EtherCAT network operation failed due to a network communication error.	<ul style="list-style-type: none"> Check the EtherCAT network wiring and devices state. Re-start the application. 	SW
E32	EtherCAT communication failure during bootstrap mode.	EtherCAT network operation failed due to a network communication error.	<ul style="list-style-type: none"> Check the EtherCAT network wiring and devices state. Re-start the application. 	SW

Code	Description	Cause	Remedy	How to Clear**
** In the How to Clear column: An HW requires a reboot to clear the error or alarm. An SW error or alarm can be cleared from the web server.				
E33	EtherCAT failed to initialize into operational mode.	EtherCAT network initialization failed. <ul style="list-style-type: none"> This is commonly caused by the EtherCAT configuration in the project not matching the actual hardware. See the IDE Controller log for more information. 	<ul style="list-style-type: none"> Check the EtherCAT network wiring and devices state. Re-start the application. See "Why am I getting an E33 error?" (→ p. 827). 	SW
E34	EtherCAT failed to initialize into pre-op mode.	EtherCAT network initialization failed due to a network communication error.	<ul style="list-style-type: none"> Check the EtherCAT network wiring and devices state. Re-start the application. 	SW
E35	EtherCAT failed to initialize into bootstrap mode.	EtherCAT network initialization failed due to a network communication error.	<ul style="list-style-type: none"> Check the EtherCAT network wiring and devices state. Re-start the application. 	SW
E36	EtherCAT failed to discover the expected devices.	EtherCAT network discovery failed due to a mismatch between the discovered and expected devices.	<ul style="list-style-type: none"> Check the EtherCAT devices and wiring order. Correct the device order wiring or re-scan the network, re-compile, and download the updated application. Re-start the application. 	SW
E37	EtherCAT failed to return to init state.	EtherCAT network initialization failed due to a network communication error.	<ul style="list-style-type: none"> Check the EtherCAT network wiring and devices state. Re-start the application. 	SW

Code	Description	Cause	Remedy	How to Clear**
** In the How to Clear column: An HW requires a reboot to clear the error or alarm. An SW error or alarm can be cleared from the web server.				
E50	Backup to SD card / USB flash drive failed.	An unrecoverable error occurred during the backup operation.	AKD PDMM and PCMM <ul style="list-style-type: none"> Repeat the backup to SD card operation. If it fails again, replace the SD card. PCMM2G <ul style="list-style-type: none"> Repeat the backup to USB flash drive operation. If it fails again, replace the USB flash drive. 	SW
E51	Restore from SD card / USB flash drive failed.	An unrecoverable error occurred during the restore operation.	Do not reboot the Controller! <ul style="list-style-type: none"> Repeat the restore operation. If it fails again, reset the Controller to factory defaults. If the problem persists, return the hardware for repair. 	SW

Code	Description	Cause	Remedy	How to Clear**
** In the How to Clear column: An HW requires a reboot to clear the error or alarm. An SW error or alarm can be cleared from the web server.				
E52	SD card / USB flash drive Backup files are missing or corrupt.	The restore operation failed due to missing, incomplete, or corrupt files on the SD card / USB flash drive.	AKD PDMM and PCMM <ul style="list-style-type: none"> Perform a backup operation before the restore. Use an SD card with valid backup files. PCMM2G <ul style="list-style-type: none"> Perform a backup operation before the restore. Use a USB flash drive with valid backup files. 	SW
E53	AKD PDMM and PCMM only. SD card Backup files are not compatible.	AKD PDMM and PCMM only. Backup files on the SD card are not compatible.	AKD PDMM and PCMM only. <ul style="list-style-type: none"> Use a different SD card with Backup files from a compatible controller. 	SW: AKD PDMM and PCMM only.

Code	Description	Cause	Remedy	How to Clear**
** In the How to Clear column: An HW requires a reboot to clear the error or alarm. An SW error or alarm can be cleared from the web server.				
E60	PCMM2G only. Inactive partition is corrupted.	PCMM2G only. An unrecoverable error occurred when starting KAS Runtime on the inactive partition.	PCMM2G only. These are the recovery steps. If Step 1 is not successful, go to Step 2 and continue to Step 3 if needed. <ol style="list-style-type: none"> 1. Re-download firmware. 2. Boot into recovery mode, download firmware, and power-off/on. See "Recover Using the Web server" (→ p. 428) for more information. 3. If the problem persists, return the hardware for repair. See "Booting the PCMM2G Controller" (→ p. 375) for more information about partitions.	SW: PCMM2G only.

11.2 Alarms

Code	Description	Cause	Remedy	How to Clear**
** In the How to Clear column: An HW requires a reboot to clear the error or alarm. An SW error or alarm can be cleared from the web server.				
A01	High temperature exceeded.	CPU temperature near the safe operating temperature limit for: <ul style="list-style-type: none"> • PCMM = 120 °C. • PCMM2G = 78 °C 	Check airflow and operating environment are within hardware specifications.	SW
A02	Low on memory.	Memory leak or corruption.	<ul style="list-style-type: none"> • Power-off/on. • If the problem is recurrent, check the Release Notes for firmware updates. • If the problem persists, return the hardware for repair. 	SW
A04	Low input voltage.	+24 volt input power is +19 volts or less.	Check power supply voltage and connection to the controller.	SW
A05	PCMM2G only. The system time was not set on startup.	PCMM2G only. <ul style="list-style-type: none"> • Network Time Protocol (NTP) is disabled. <ul style="list-style-type: none"> • The time could not be retrieved at startup. • This is most likely caused by a dead or missing battery. 	PCMM2G only. Either: <ul style="list-style-type: none"> • Insert a good battery and set the time. • Enable NTP. • See "Date/Time tab" (→ p. 417) for more information. 	SW: PCMM2G only.
A12	Flash memory is low on free space.	Flash memory is almost full.	Clean-up the flash memory by removing log files, application programs, recipes, or other data files. Reset to factory defaults.	SW
A21	Recoverable process or thread failed to respond during operation.	KAS non-runtime code failed during normal operation and was automatically restarted.	<ul style="list-style-type: none"> • Power-off/on. • If the problem is recurrent, check the Release Notes for firmware updates. 	SW

Code	Description	Cause	Remedy	How to Clear**
** In the How to Clear column: An HW requires a reboot to clear the error or alarm. An SW error or alarm can be cleared from the web server.				
A23	CPU is heavily loaded.	CPU usage is too high for 5 (or more) seconds.	Reduce the sample rate, simplify the application, or reduce the application cycles.	SW
A30	EtherCAT missed a send frame during operation mode.	The EtherCAT master was unable to send a frame for one or more cycles.	Reduce the controller CPU load so it has enough Real-Time margin to send EtherCAT frames every cycle.	SW
A31	EtherCAT received a frame with a wrong Working Counter value. See "Actual Position Interpolation" (→ p. 682).	<ul style="list-style-type: none"> The slave EtherCAT device does not exist or cannot be physically reached due to connector and/or cable failure. Slave hardware failure Slave is still busy with a previous command and is not ready. 	<ul style="list-style-type: none"> Check the EtherCAT cables and the connectors. Check the EtherCAT devices for any device errors. 	
A38	EtherCAT missed a receive frame during operation mode. See "Actual Position Interpolation" (→ p. 682).	The EtherCAT master did not receive, or received too late, a frame for one or more cycles.	<ul style="list-style-type: none"> Read the AKD-x parameter ECAT.DIAG for more information on where in the EtherCAT network the issue may be occurring. <ul style="list-style-type: none"> See Debugging Intermittent EtherCAT Communication Issues on KDN for more information. Check the EtherCAT network wiring and devices state. Decrease the EtherCAT cycle rate. 	SW
A40	Local digital IO missed a cyclic update.	Local digital IO was not updated during a cycle or the updates are no longer synchronous.	Reduce the sample rate, simplify the application, or reduce the application cycles.	SW

Code	Description	Cause	Remedy	How to Clear**
** In the How to Clear column: An HW requires a reboot to clear the error or alarm. An SW error or alarm can be cleared from the web server.				
A53	AKD PDMM and PCMM only. The controller was replaced with a higher performance model.	AKD PDMM and PCMM only. The 1.2GHz model was restored using backup files from an 800MHz model.	AKD PDMM and PCMM only. Either: <ul style="list-style-type: none"> Replace the controller with an 800MHz model. Use the functionally compatible, higher performance 1.2GHz model. 	SW: AKD PDMM and PCMM only.

11.3 Actual Position Interpolation

- If EtherCAT actual position data is missing due to a corrupted, late, or missing EtherCAT frame ("A31" (→ p. 681) or "A38" (→ p. 681)), the controller interpolates the actual position data for servo axes, digitizing axes, and pipe network sampler blocks.
- The interpolation reduces velocity discontinuities when the actual position data is used for camming and gearing.

11.4 CPU Overload (E23)

If the Motion Engine or PLC program execution (VM) do not complete a full cycle within their respective timeout periods, an "E23" (→ p. 673) error is flashed on the 7-segment display.



Process	Timeout
Motion Engine	200 milliseconds
PLC Program (VM)	10 seconds



The Real-Time operation for EtherCAT and the Motion Engine have the highest priority in the controller.

- The PLC VM has the second highest priority in the controller.
- These processes continue to execute, even if their timeout values are exceeded.

If the CPU overload is severe, there may not be enough CPU time to execute the background operations.

- The background operations include the 7-segment display update, monitoring push-buttons, web-server, Modbus, and communications with the KAS-IDE.
- The 7-segment display indicates a CPU overload or frozen software task using one of these patterns:

Display	Meaning	Applicable Controller
	CPU overload is extreme.	<ul style="list-style-type: none"> • AKD PDMM • PCMM • PCMM2G
	Motion thread is no longer able to execute.	AKD PDMM and PCMM only.
	EtherCAT Rx thread is no longer able to execute.	AKD PDMM and PCMM only.

Display	Meaning	Applicable Controller
	PLC thread is no longer able to execute.	AKD PDMM and PCMM only.
	Non-realtime threads are no longer able to execute.	AKD PDMM and PCMM only.

To recover from an E23, stop the application from the IDE or web-browser (KAS Application view).

- If the CPU overload is severe, the controller may not have enough CPU time to respond to the IDE or web-browser.
 - If so, power off/on the controller.
- If the controller is configured for Auto-start, press and hold the B3 menu button at boot-time to prevent the application from automatically re-starting.
 - Then, connect to the controller with the KAS-IDE.

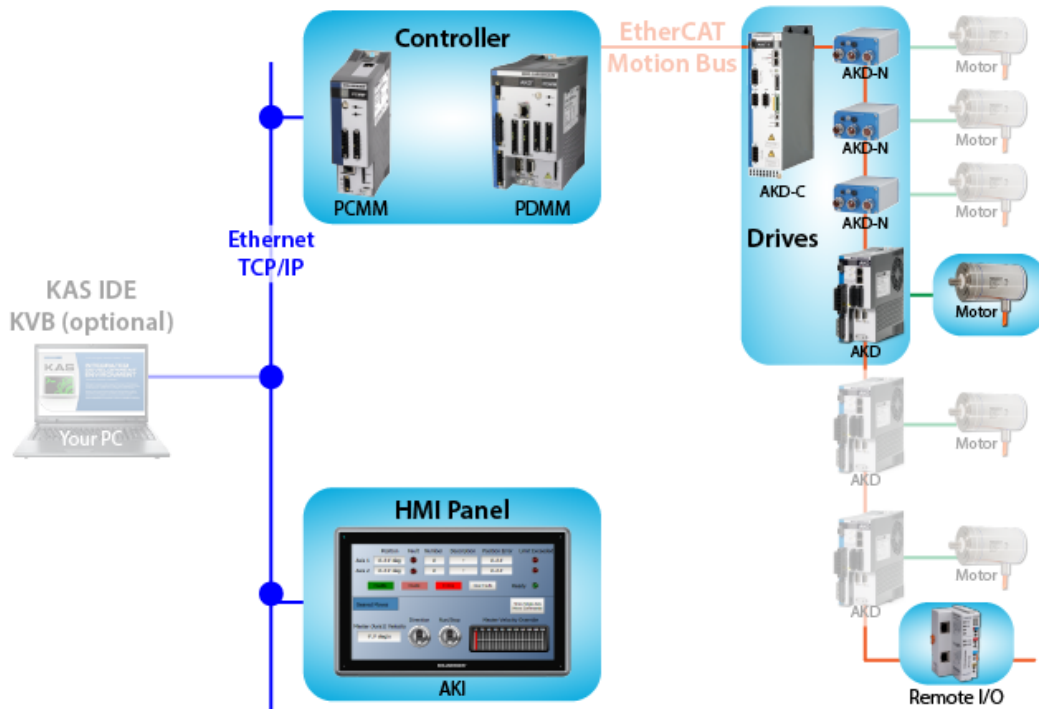

12 KAS Component Manuals



12.1 BBH FSoE Master

This [BBH Products](#) Safety equipment is required to program and operate the SCU-1-EC FSoE Safety master with these Kollmorgen products:

- AKD2G
- AKD PDMM
- AKT2G-SDI-004-000
- AKT2G-SDO-004-000
- KAS-IDE software
- PCMM

Part Number	Description	Image
SCU-1-EC	FSoE Master - modular basic module	
SMX91	Programming adapter (cable)	
SafePLC2	Programming software, License including Hardlock	

Order these items from Kollmorgen.

12.2 Controllers

Controller	Description	Model Number	Main Characteristics
PCMM2G	1.5GHz Quad-core	PCMM2G-C2-08-000-00-000	2 nd Generation High Performance Multi-Axis Controller
PCMM	1.2GHz Dual-core	AKC-PCM-M2-120-00N-00-000	High Performance Multi-Axis Controller
PCMM	1.2GHz Single-core	AKC-PCM-M1-120-00N-00-000	High Performance Multi-Axis Controller
PCMM	800MHz Single-core	AKC-PCM-MC-080-00N-00-000	Standard Multi-Axis Controller
AKD PDMM	1.2GHz	AKD-M0xxx-M1EC-0000 AKD-M0xxx-K1EC-0000	High Performance Drive Resident Controller
AKD PDMM	800MHz	AKD-M0xxx-MCEC-0000 AKD-M0xxx-KCEC-0000	Standard Drive Resident Controller

12.2.1 Controller Differences

These tables list the software and hardware differences between AKD PDMM, PCMM, and PCMM2G:

- "Hardware Differences" (→ p. 686)
- "Software Differences" (→ p. 687)

See these additional specification topics:

- "PCMM Specifications" (→ p. 688).
- "PCMM2G Specifications" (→ p. 689).

12.2.1.1 Hardware Differences

Specification	AKD PDMM and PCMM	PCMM2G
Battery	N/A	<ul style="list-style-type: none"> • CR2032 Lithium Manganese Dioxide primary cell, 3V. • At least 190mAh.
Certifications	CE, UL	TBD
Critical Temperature Limit (CPU)	127 °C	83 °C
Dimensions	174 mm (H) x 50 mm (W) x 111.5 mm (D)	174 mm (H) x 50 mm (W) x 111.5 mm (D)
External Memory	<ul style="list-style-type: none"> • Removable SD Card slot. • SD Card not included. 	<ul style="list-style-type: none"> • Removable USB flash drive slot. • USB flash drive not included.
High Temperature Limit (CPU)	120 °C	78 °C
Input Power	24VDC @ 1.25A	TBD
Internal Memory	64MB Flash memory for program storage.	16GB Flash memory
Local I/O	<ul style="list-style-type: none"> • 6 digital inputs • 2 digital outputs 	<ul style="list-style-type: none"> • 6 digital inputs • 2 digital outputs
Motion Network	EtherCAT, max 4kHz update rate	EtherCAT, max 4kHz update rate

Specification	AKD PDMM and PCMM	PCMM2G
Networking Protocols	1 Ethernet Port 100BaseT connection supporting: <ul style="list-style-type: none"> • EtherNet/IP • HTTP • Modbus TCP • PROFINET • TCP/IP • UDP 	2 Ethernet Ports 100BaseT connection supporting: <ul style="list-style-type: none"> • EtherNet/IP • HTTP • Modbus TCP • PROFINET • TCP/IP • UDP
Operating Temperature (ambient range)	0 °C to 55 °C	0 °C to 55 °C
Processor	<ul style="list-style-type: none"> • 800MHz (MC model) • 1.2GHz (M1 model) • Dual-core 1.2GHz (M2 model) 	Quad-core 1.5GHz (ARM Cortex A-72 processor)
Sealing	IP20	IP20

12.2.1.2 Software Differences

TBD

12.2.2 AKD PDMM Specifications

The AKD PDMM combines an AKD servo drive with an embedded motion controller in a single, compact package.

AKD PDMM can control a maximum of 64 axes on a machine. It provides integrated control for multiple high-performance axes, complete I/O, and HMI interfaces.

12.2.2.1 AKD PDMM Specifications

Specification	Description
Certifications	CE, UL
Critical Temperature Limit (CPU)	127 °C
Dimensions	174 mm (H) x 50 mm (W) x 111.5 mm (D)
External Memory	Removable SD Card slot. SD Card not included.
High Temperature Limit (CPU)	120 °C
Input Power	24VDC @ 1.25A
Internal Memory	64MB Flash memory for program storage.
Local I/O	<ul style="list-style-type: none"> • 6 digital inputs • 2 digital outputs
Motion Network	EtherCAT, max 4kHz update rate

Specification	Description
Networking Protocols	100BaseT connection supporting: <ul style="list-style-type: none"> • EtherNet/IP • HTTP • Modbus TCP • PROFINET • TCP/IP • UDP
Operating Temperature (ambient range)	0 °C to 55 °C
Processor	<ul style="list-style-type: none"> • 800MHz (MCEC model) • 1.2GHz (M1EC model)
Sealing	IP20

12.2.2.2 AKD-Mxxx Model Specifications

Model	Voltage	Continuous Current (Arms)	Peak Current (Arms)	Dimensions
AKD-M00306-xxEC-0000	<ul style="list-style-type: none"> • 120/240VAC • 1- and 3-Phase 	3	9	168 x 89 x 156mm
AKD-M00606-xxEC-0000	<ul style="list-style-type: none"> • 120/240VAC • 1- and 3-Phase 	6	18	168 x 89 x 156mm
AKD-M01206-xxEC-0000	<ul style="list-style-type: none"> • 120/240VAC • 1- and 3-Phase 	12	30	192 x 107 x 187mm
AKD-M02406-xxEC-0000	<ul style="list-style-type: none"> • 120/240VAC • 1- and 3-Phase 	24	48	248 x 96 x 228mm
AKD-M00307-xxEC-0000	<ul style="list-style-type: none"> • 240/400/480VAC • 3-Phase 	3	9	256 x 99 x 185mm
AKD-M00607-xxEC-0000	<ul style="list-style-type: none"> • 240/400/480VAC • 3-Phase 	6	18	256 x 99 x 185mm
AKD-M01207-xxEC-0000	<ul style="list-style-type: none"> • 240/400/480VAC • 3-Phase 	12	30	256 x 99 x 185mm
AKD-M02407-xxEC-0000	<ul style="list-style-type: none"> • 240/400/480VAC • 3-Phase 	24	48	306 x 99 x 228mm
AKD-M04807-xxEC-0000	<ul style="list-style-type: none"> • 240/400/480VAC • 3-Phase 	48	96	385 x 185 x 225mm

12.2.3 PCMM Specifications

The PCMM programmable motion controller delivers a small yet powerful and cost-effective hardware platform. PCMM is ideally suited for modular or stand-alone machines that want the maximum in flexibility and performance.

Specification	Description
Battery	N/A

Specification	Description
Certifications	CE, UL
Critical Temperature Limit (CPU)	127 °C
Dimensions	174 mm (H) x 50 mm (W) x 111.5 mm (D)
External Memory	Removable SD Card slot. SD Card not included.
High Temperature Limit (CPU)	120 °C
Input Power	24VDC @ 1.25A
Internal Memory	64MB Flash memory for program storage.
Local I/O	<ul style="list-style-type: none"> • 6 digital inputs • 2 digital outputs
Motion Network	EtherCAT, max 4kHz update rate
Networking Protocols	1 Ethernet Port 100BaseT connection supporting: <ul style="list-style-type: none"> • EtherNet/IP • HTTP • Modbus TCP • PROFINET • TCP/IP • UDP
Operating Temperature (ambient range)	0 °C to 55 °C
Processor	<ul style="list-style-type: none"> • 800MHz (MC model) • 1.2GHz (M1 model) • Dual-core 1.2GHz (M2 model)
Sealing	IP20

12.2.4 PCMM2G Specifications

The PCMM2G programmable motion controller delivers a small yet powerful and cost-effective hardware platform.

PCMM2G is ideally suited for modular or stand-alone machines that want the maximum in flexibility and performance.

Specification	Description
Battery	<ul style="list-style-type: none"> • CR2032 Lithium Manganese Dioxide primary cell, 3V. • At least 190mAh.
Certifications	CE, RoHS, UKCA, UL
Critical Temperature Limit (CPU)	83 °C
Dimensions	174 mm (H) x 50 mm (W) x 111.5 mm (D)
External Memory	Removable USB flash drive slot. USB flash drive not included.
High Temperature Limit (CPU)	78 °C
Input Power	24VDC @ 1.25A

Specification	Description
Internal Memory	16GB Flash memory
Local I/O	<ul style="list-style-type: none"> • 6 digital inputs • 2 digital outputs
Motion Network	EtherCAT, max 4kHz update rate
Networking Protocols	2 Ethernet Ports 100BaseT connection supporting: <ul style="list-style-type: none"> • EtherNet/IP • HTTP • Modbus TCP • PROFINET • TCP/IP • UDP
Operating Temperature (ambient range)	0 °C to 55 °C
Processor	Quad-core 1.5GHz (ARM Cortex A-72 processor)
Sealing	IP20

12.2.5 Part Number Scheme

Use the part number scheme for product identification only.

Do not use it for the order process because not all features can always be combined among each other.

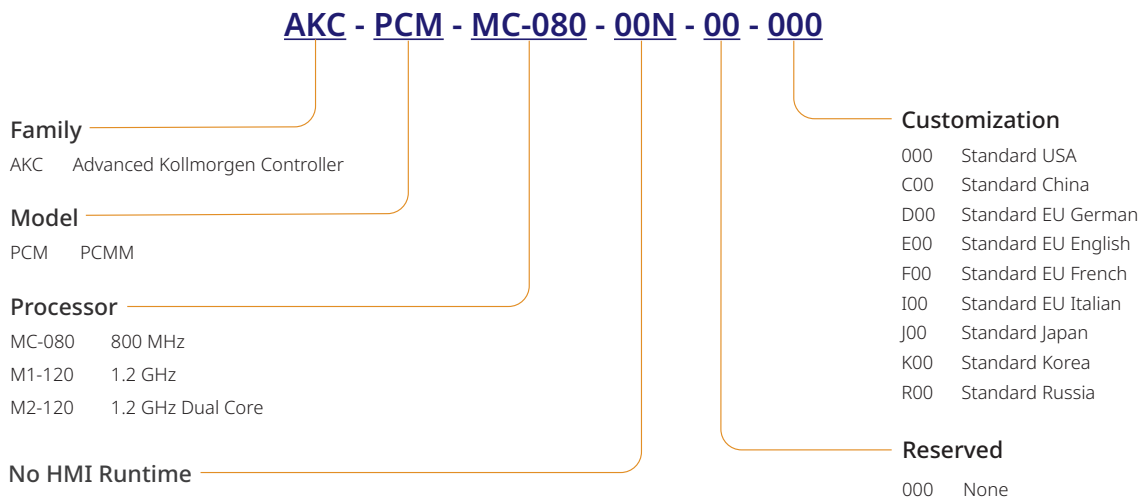

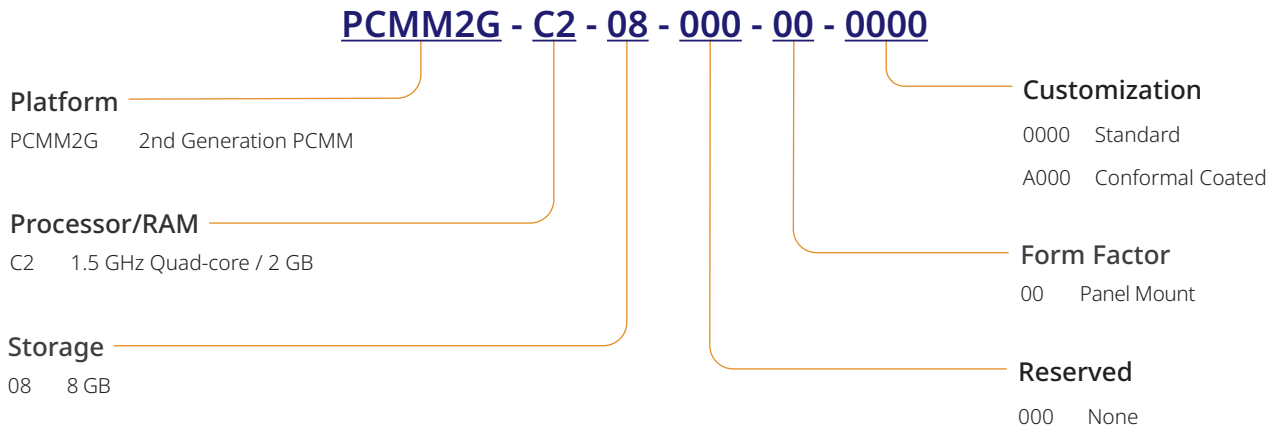

12.2.6 NVRAM

KAS uses NVRAM to save "Retain Variables" (→ p. 707).

Hardware Type	NVRAM Size Allocation
Simulator	256 Kbytes
AKD PDMM or PCMM	32 Kbytes
PCMM2G	256 Kbytes

ⓘ IMPORTANT

Part of NVRAM allocation is reserved to store some internal data (144 bytes).
As a consequence, not all of the complete physical NVRAM is available for the retain variables.

If the size is big enough, KAS updates the non-volatile memory to store the retain variables values.

- This operation is performed in the background every 20 seconds.
- The frequency increases to every two seconds when the application is running or when you shutdown the application.

12.2.6.1 NVRAM Life Expectancy

- **Data Retention:** At maximum operating temperature, the data written to the memory is retained for 10 years.
- **Endurance:** NVRAM memory has an endurance limit of 10^{14} read/write accesses.
 - More than 6,000,000 years of being accessed every 2 seconds.

NOTE

Using the retain variables is very cycle time consuming.
As a consequence, Kollmorgen strongly recommends to carefully monitor the system load with the [TraceTimes](#) command.

12.2.6.1.1 Verify the NVRAM Space

To calculate NVRAM space, add the size of each retained variable according to the:

- "Data Types" (→ p. 702)
- "Arrays" (→ p. 703) - The numbers of elements in case the variable is declared as an array.

Remember! Add the 144 bytes!

In this example, the total size is: **3684 bits** (which is less than 0.5 Kbytes).

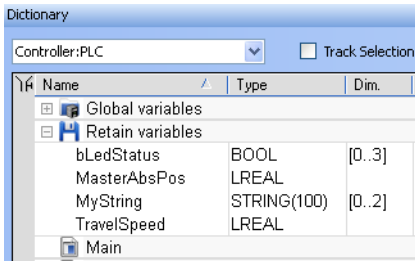

Variable	Size / element	Number of Element	Total Size / variable
bLedStatus	1-bit	4	4
Internal data	1152-bits (144 bytes)	N/A	1152
MasterAbsPos	64-bits	1	64
MyString	800-bits (100 bytes)	3	2400
TravelSpeed	64-bits	1	64

12.3 Drives

These websites provide detailed information about drives:

- [AKD® Series Servo Drives](#)
- [AKD2G Servo Drive](#)
- [AKD-N Decentralized Servo Drive](#)

12.3.1 Related Documents

See these manuals for additional information on drives:

Drive Manuals	Description
AKD EtherCAT Manual	Describes the installation, setup, range of functions, and software protocol for the EtherCAT AKD product series.
AKD Installation Manual	<ul style="list-style-type: none"> • Installation manual for AKD and AKD PDMM drives. • Describes the AKD series of digital drives and includes mechanical, electrical, and software installation information needed to safely install AKD.
AKD PDMM Fault Card	<ul style="list-style-type: none"> • Describes the AKD PDMM (including AKD) faults, warnings, error messages, and alarms. • Provides cause and remedy instructions to determine the specifics of the failure and to correct the underlying problem.
AKD PDMM User Manual	<ul style="list-style-type: none"> • Describes the software installation, setup, and operation for the AKD PDMM drive. • Includes basic topics and examples to help set up and use the various features in the drive.
AKD, AKD2G, S700 (in NA) Accessories Manual	Describes the accessories for Kollmorgen digital drive systems and servo drive motors.
AKD2G EtherCAT Manual	Describes the installation, setup, range of functions, and software protocol for the AKD2G product series.
AKD2G Installation Manual	<ul style="list-style-type: none"> • Describes the AKD2G series of digital drives. • Includes mechanical, electrical, software, and functional safety options.

Drive Manuals	Description
MKD Installation Manual	<ul style="list-style-type: none"> • Installation manual for MKD-N power supply and MKD-C drives. • Describes the MKD devices and includes mechanical, electrical, and software installation information needed to safely install the devices.
S300 Reference Documentation	Kollmorgen website with access to all S300 manuals.
S700 Reference Documentation	Kollmorgen website with access to all S700 manuals.

NOTE

The AKD manuals are located here:
C:\Program Files\Kollmorgen\AKD WorkBench 1.0.x.y\WebHelp.
x.y must be replaced with the version number.
This location differs if a different location was chosen when installing AKD.

12.3.2 AKD-M Kx PDMM Controller / Drive Variant

The AKD-M Kx PDMM is a controller / drive variant introduced in 2022 with a substitute chip.

It is identified with **-Kx** the part number:

AKD-M-xxxxx-KCEC-xxxx

AKD-M-xxxxx-K1EC-xxxx

Contact your local Kollmorgen representative for more information about the AKD-M PDMM.

12.3.2.1 FAQs for the Kx Controller / Drive

[Which AKD firmware versions support the AKD **-Kx** controller / drive?](#)

AKD firmware v01-21-02-000 and later support the **-Kx** controller / drive.

[Which versions of the KAS-IDE are compatible with the AKD **-Kx** controller / drive?](#)

KAS-IDE v3.07.0.88325 and later are compatible.

Kollmorgen recommends using v3.07.0.88325 and later because the drive features available in AKD firmware v01-21-02 are integrated with and supported by KAS-IDE v3.07.0.88325.

[Are there any backwards compatibility issues with the AKD **-Kx** controller / drive?](#)

EtherCAT Devices Backup and Restore requires AKD firmware v01-21-02-000 at a minimum.

The firmware for the **-Kx** controller / drive is not available in the backup files if the existing backup contains older firmware.

See "EtherCAT Devices Backup" (→ p. 391) to update the backup files.

[Where can I find the KAS firmware package with **-Kx** support?](#)

The AKD firmware and KAS firmware packages are available in the downloads section of Kollmorgen website.

- [AKD backup/restore firmware package](#)
- [AKD firmware](#)

[Which AKD PDMM controller / drive variants can be swapped with the **-Kx** model?](#)

The **Mx** variants are functionally compatible and can be swapped using the "Backup and Restore tab" (→ p. 390) feature.

[What is the recommended usage for **-Kx** controller / drive?](#)

Kollmorgen recommends using the **-Kx** PDMM controller / drives for new machines.

Kollmorgen does **not** recommend using **-Kx** PDMM controller / drives as replacements with existing machines because this may require a drive firmware upgrade and an update to existing EtherCAT devices backup files.

12.3.3 AKD-N "ES" Drive Variant

The AKD-N "ES" is a drive variant introduced in 2022 with a substitute chip.

It is identified with "-ES" the part number:

AKD-N-xxxxx-ESxx-xxxx

Contact your local Kollmorgen representative for more information about the drive.

12.3.3.1 FAQs for the "ES" Drive

[Which AKD firmware versions support the AKD-N "ES" drive?](#)

AKD firmware v01-22-00-000 and later support the "ES" drive.

[Which versions of the KAS-IDE are compatible with the AKD-N "ES" drive?](#)

KAS-IDE v4.00 and later are compatible.

Kollmorgen recommends using v4.00 and later because the drive features available in AKD firmware v01-22 are integrated with and supported by KAS-IDE v4.00.

[Are there any backwards compatibility issues with the AKD-N "ES" drive?](#)

EtherCAT Devices Backup and Restore requires AKD firmware v01-22-00-000 at a minimum.

The firmware for the "ES" drive is not available in the backup files if the existing backup contains older firmware.

See "EtherCAT Devices Backup" (→ p. 391) to update the backup files.

[Where can I find the KAS firmware package with "ES" support?](#)

The AKD firmware and KAS firmware packages are available in the downloads section of Kollmorgen website.

- [AKD backup/restore firmware package](#)
- [AKD firmware](#)

[Which AKD-N drive variants can be swapped with the "ES" model?](#)

The "NB" variants are functionally compatible and can be swapped using the "Backup and Restore tab" (→ p. 390) feature.

[What is the recommended usage for "ES" drives?](#)

Kollmorgen recommends using "ES" drives for new machines.

We do not recommend using "ES" drives as replacements with existing machines because this may require a drive firmware upgrade and an update to existing EtherCAT devices backup files.

12.3.4 AKD-P "NC" Drive Variant

The AKD-P "NC" is a drive variant introduced in 2021 with a substitute chip.

It is identified with "-NC" in the part number:

AKD-Pxxxxx-NCxx-xxxx

Contact your local Kollmorgen representative for more information about the drive.

12.3.4.1 FAQs for the "NC" Drive

[Which AKD firmware versions support the AKD "NC" drive?](#)

AKD firmware v01-20-00-003 and later support the "NC" drive.

Which versions of the KAS-IDE are compatible with the AKD "NC" drive?

KAS-IDE v2.09 and later are compatible.

Kollmorgen recommends using v3.05 and later because the drive features available in AKD firmware v01-20 are integrated with and supported by KAS-IDE v3.05.

Are there any backwards compatibility issues with the AKD "NC" drive?

EtherCAT Devices Backup and Restore requires AKD firmware v01-20-00-003 at a minimum.

The firmware for the "NC" drive is not available in the backup files if the existing backup contains older firmware.

See "EtherCAT Devices Backup" (→ p. 391) to update the backup files.

Where can I find the KAS firmware package with "NC" support?

The AKD firmware and KAS firmware packages are available in the downloads section of the Kollmorgen website.

- [AKD backup/restore firmware package](#)
- [AKD firmware](#)

Which AKD drive variants can be swapped with the "NC" model?

The "NB" variants are functionally compatible and can be swapped using the "Backup and Restore tab" (→ p. 390) feature.

What is the recommended usage for "NC" drives?

Kollmorgen recommends using "NC" drives for new machines.

We do not recommend using "NC" drives as replacements with existing machines because this may require a drive firmware upgrade and an update to existing EtherCAT devices backup files.

12.3.5 AKD-P "ND" Drive Variant

The AKD-P "ND" is a drive variant introduced in 2022 with a substitute chip.

It is identified with "-ND" in the part number:

AKD-Pxxxxx-NDxx-xxxx

Contact your local Kollmorgen representative for more information about the drive.

12.3.5.1 FAQs for the "ND" Drive

Which AKD firmware versions support the AKD "ND" drive?

AKD firmware v01-21-02-000 and later support the "ND" drive.

Which versions of the KAS-IDE are compatible with the AKD "ND" drive?

KAS-IDE v3.07.0.88325 and later are compatible.

Kollmorgen recommends using v3.07.0.88325 and later because the drive features available in AKD firmware v01-21-02 are integrated with and supported by KAS-IDE v3.07.0.88325.

Are there any backwards compatibility issues with the AKD "ND" drive?

EtherCAT Devices Backup and Restore requires AKD firmware v01-21-02-000 at a minimum.

The firmware for the "ND" drive is not available in the backup files if the existing backup contains older firmware.

See "EtherCAT Devices Backup" (→ p. 391) to update the backup files.

Where can I find the KAS firmware package with "ND" support?

The AKD firmware and KAS firmware packages are available in the downloads section of the Kollmorgen website.

- [AKD backup/restore firmware package](#)
- [AKD firmware](#)

Which AKD drive variants can be swapped with the "ND" model?

The "NB" and "NC" variants are functionally compatible and can be swapped using the "Backup and Restore tab" (→ p. 390) feature.

What is the recommended usage for "ND" drives?

Kollmorgen recommends using "ND" drives for new machines.

We do not recommend using "ND" drives as replacements with existing machines because this may require a drive firmware upgrade and an update to existing EtherCAT devices backup files.

12.3.6 MKD-C "ND" Central Power Supply Variant

The MKD-C "ND" is a central power supply variant introduced in 2022 with a substitute chip.

It is identified with "-NC" in the part number:

MKD-Cxxxxxx-ND-xxxx

Contact your local Kollmorgen representative for more information about the drive.

12.3.6.1 FAQs for the "ND" Central Power Supply

Which AKD firmware versions support the MKD-C "ND" central power supply?

AKD firmware v01-22-00-000 and later support the "ND" central power supply.

Which versions of the KAS-IDE are compatible with the MKD-C "ND" central power supply?

KAS-IDE v4.00 and later are compatible.

Kollmorgen recommends using v4.00 and later because the features available in AKD firmware v01-22 are integrated with and supported by KAS-IDE v4.00.

Are there any backwards compatibility issues with the MKD-C "ND" central power supply?

The MKD-C "ND" support was introduced in KAS-IDE v4.00 with AKD firmware v01-22.

Previous MKD-C central power supplies are not supported.

Where can I find the KAS firmware package with "ND" support?

The AKD firmware and KAS firmware packages are available in the downloads section of Kollmorgen website.

- [AKD backup/restore firmware package](#)
- [AKD firmware](#)

Which MKD-C "ND" central power supply variants can be swapped with the "ND" model?







Previous models are not supported and should not be swapped with the "ND" model.

What is the recommended usage for MKD-C "ND" central power supply?

Kollmorgen recommends using MKD-C "ND" central power supply for new machines.

12.4 HMI

HMI Part Number	Description	KVB	Manual
AKI-CDC-MOD-21T-000	Graphical Display 21.5" TFT LCD, Touchscreen	v2.0	

HMI Part Number	Description	KVB	Manual
AKI-CDC-MOD-15T-000	Graphical Display 15.4" TFT LCD, Touchscreen	v2.0	
AKI-CDC-MOD-12T-000	Graphical Display 12.1" TFT LCD, Touchscreen	v2.0	
AKI2G-CDA-MOD-07T-000	Graphical Display 5" TFT LCD, Touchscreen	v2.20	
AKI2G-CDA-MOD-05T-000	Graphical Display 7" TFT LCD, Touchscreen	v2.20	
AKI2G-CDB-MOD-12T-000	Graphical Display 12" TFT LCD, Touchscreen	v2.20	
AKI2G-CDB-MOD-07T-000	Graphical Display 7" TFT LCD, Touchscreen	v2.20	

NOTE

See our [Web site](#) for up-to-date information and material available in the **Automation Component Solutions** section.

You must log in before accessing KAS Literature.

Scan this QR code to access our web site with your mobile device.



12.4.1 HMI Accessories

Various accessories are available to compliment the HMI, including:

- Programming Cable, RS232 to HMI Terminal RS232
- Key cover for 5.7" Graphical Display
- Key cover for 10.4" Graphical Display
- Touch cover for 3.5" Touchscreen Graphical Display
- Touch cover for 5.7" Touchscreen Graphical Display
- Touch cover for 10.4" Touchscreen Graphical Display
- Touch cover for 15.1" Touchscreen Graphical Display
- 512 MB Compact Flash Industrial Grade
- 1 GB Compact Flash Industrial Grade

12.5 Remote Input/Output Terminals

KAS remote I/Os provide a complete spectrum of bus couplers, digital and analog inputs, digital and analog outputs, stepper, counter, and thermocouple modules.

Related Documents

This table is a list of each I/O component available.

I/O Terminal Part Number	I/O Terminal Description
AKT2G-AC-FAN-001	Fan cartridge for EtherCAT and Bus Terminals.

I/O Terminal Part Number	I/O Terminal Description
AKT2G-AN-240-000	<ul style="list-style-type: none"> • 2-channel input terminal PT100 (RTD) for resistance sensors. • 16-bit, 2-, 3-wire system.
AKT2G-AN-400-000	<ul style="list-style-type: none"> • 4-channel thermocouple input terminal. • Preset to type K, with wire breakage detection. • 16-bit
AKT2G-AN-430-000	<ul style="list-style-type: none"> • 4-channel analog input. • Parameter capable • -10/0 to 10V • -20/0/+4 to +20mA • 16-bit
AKT2G-AT-410-000	<ul style="list-style-type: none"> • 4-channel analog output terminal. • 0 to 10V • 1-wire system • 12-bit
AKT2G-AT-425-000	<ul style="list-style-type: none"> • 4-channel analog output terminal. • -10V to +10V • 4 x 2-wire system • 12-bit
AKT2G-BRC-000-000	Brake Chopper Terminal
AKT2G-DN-002-000	<ul style="list-style-type: none"> • Up/down counter 24V_{DC} • 100 kHz • 32-bit counter depth
AKT2G-DN-008-000	<ul style="list-style-type: none"> • 8-channel digital input terminal 24V_{DC}. • Filter 3.0ms • 1-wire system
AKT2G-DNH-008-000	<ul style="list-style-type: none"> • 8-channel digital input terminal 24V_{DC}. • Filter 10μs • 1-wire system
AKT2G]DT-008-000	<ul style="list-style-type: none"> • 8-channel digital output terminal 24V_{DC} • 0.5A • 1-wire system
AKT2G-ECT-000-000	EtherCAT Coupler for E-bus terminals
AKT2G-EM-000-000	<ul style="list-style-type: none"> • Bus end cover for E-bus terminals • Cover for power and E-bus contacts, gray
AKT2G-ENC-180-000	<ul style="list-style-type: none"> • 1-channel incremental encoder interface • 32-bit
AKT2G-ENC-190-000	<ul style="list-style-type: none"> • Incremental encoder interface with differential input • 16-bit / 32-bit
AKT2G-PSF-024-000	<ul style="list-style-type: none"> • Power supply terminal with fuse • 24V_{DC}
AKT2G-SDI-004-000	<ul style="list-style-type: none"> • 4-channel digital input terminal 24V_{DC}. • Safety
AKT2G-SDO-004-000	<ul style="list-style-type: none"> • 4-channel digital input terminal 24V_{DC}. • Safety • 0.5A

I/O Terminal Part Number	I/O Terminal Description
AKT2G-SM-L15-000	<ul style="list-style-type: none"> • Stepper motor terminal • 24V_{DC} • 1.5A • Vector control
AKT2G-SM-L50-000	<ul style="list-style-type: none"> • Stepper motor terminal • 50V_{DC} • 5A • Vector control

ⓘ IMPORTANT

24-volt power is not passed through AKT-AN-200-000 and AKT-AN-400-000 thermocouple modules. These are the solutions to get 24VDC power to devices that need it (e.g., an AKT_AT-410-000 Output module):

- Place the module requiring 24VDC before the thermocouple module.
- Add a power feed module (AKT-PS-024-000 or AKT-PSF-024-000) after the thermocouple module.

I/O Terminal Part Number	Description	Replaced By
AKT-AN-200-000	2-channel thermocouple input module	AKT2G-AN-240-000
AKT-AN-400-000	4-channel thermocouple input module	AKT2G-AN-400-000
AKT-AN-410-000	<ul style="list-style-type: none"> • 4-channel analog input module • 0 to 10VDC 	AKT2G-AN-430-000
AKT-AN-420-000	<ul style="list-style-type: none"> • 4-channel analog input module • 0 to 20mA 	AKT2G-AN-430-000
AKT-AN-810-000	<ul style="list-style-type: none"> • 8-channel analog input module • 0 to 10VDC 	AKT2G-AN-430-000
AKT-AN-820-000	<ul style="list-style-type: none"> • 8-channel analog input module • 0 to 20mA 	AKT2G-AN-430-000
AKT-AT-220-000	<ul style="list-style-type: none"> • 2-channel analog output module • 0 to 20mA 	N/A
AKT-AT-410-000	<ul style="list-style-type: none"> • 4-channel analog output module • 0 to 10VDC 	N/A
AKT-AT-420-000	<ul style="list-style-type: none"> • 4-channel analog output module • 0 to 20mA 	N/A
AKT-AT-810-000	<ul style="list-style-type: none"> • 8-channel analog output module • 0 to 10VDC 	AKT2G-AT-410-000
AKT-AT-820-000	<ul style="list-style-type: none"> • 8-channel analog output module • 0 to 20mA 	N/A
AKT-DN-004-000	<ul style="list-style-type: none"> • 4-channel digital input module • 24V_{DC} • 3.0ms 	AKT2G-DN-008-000
AKT-DN-008-000	<ul style="list-style-type: none"> • 8-channel digital input module • 24V_{DC} • 3.0ms 	AKT2G-DN-008-000

I/O Terminal Part Number	Description	Replaced By
AKT-DNH-004-000	<ul style="list-style-type: none"> 4-channel digital input module 24V_{DC} 0.2ms 	AKT2G-DNH-008-000
AKT-DNH-008-000	<ul style="list-style-type: none"> 8-channel digital input module 24V_{DC} 0.2ms 	AKT2G-DNH-008-000
AKT-DT-004-000	<ul style="list-style-type: none"> 4-channel digital output module 24V_{DC} 0.5A 	AKT2G-DT-008-000
AKT-DT-008-000	<ul style="list-style-type: none"> 8-channel digital output module 24V_{DC} 0.5A 	AKT2G-DT-008-000
AKT-DT-2RT-000	<ul style="list-style-type: none"> 2-channel Relay Output Module 230VAC 2.0A Rel.2NO Pot.-Free 	N/A
AKT-ECT-000-000	EtherCAT Bus Coupler	AKT2G-ECT-000-000
AKT-EM-000-000	Standard-Bus End Terminal	AKT2G-EM-000-000
AKT-IM-000-000	Isolation / Separation Terminal	N/A
AKT-PS-024-000	Power Supply, 24V _{DC}	AKT2G-PSF-024-000
AKT-PSF-024-000	Fused Power Supply with diagnostics, 24V _{DC}	AKT2G-PSF-024-000
AKT-SM-L15-000	<ul style="list-style-type: none"> Stepper motor terminal 24V_{DC} 1.5A 	AKT2G-SM-L15-000
AKT-SM-L50-000	<ul style="list-style-type: none"> Stepper motor terminal 50V_{DC} 5A 	AKT2G-SM-L50-000

12.6 Safety Solutions

12.6.1 KSM-compact Safety Module

[KSM 5x](#)

[KSM 11](#)

[KSM 12](#)

[KSM 21R](#)

[KSM 31](#)

- For 1 or 2 safe axes.
- Maximum of 2 expansion modules.
- Base unit with 16 safe I/O.
- Expandable to a maximum 60 safe I/O.
- 1 safe relay output, expandable.
- 2 pulse outputs, 2 signal outputs.
- Expandable to a maximum 6 pulse and 6 signal outputs.
- Maximum of 800 function blocks.
- Space-saving, compact design.

12.6.2 KSM-modular Safety PLC

[KSM 100-1](#)[KSM 100-2](#)[KSM 100-4](#)[KSM 121/-2](#)[KSM 122/-2](#)[KSM 122A](#)[KSM 131](#)[KSM 131R](#)

- Maximum of 12 safe axes.
- Maximum of 8 expansion modules.
- Base unit with 56 safe I/O.
- Expandable to a maximum of 200 safe I/O.
- 1 safe relay output, expandable.
- 2 pulse outputs.
 - Maximum of 10 signal outputs.
- Expandable to a maximum of 14 pulse and 22 signal outputs.
- Maximum of 3000 function blocks.
- For applications with large number of interfaces.

12.6.3 Safety Functions (PLe & SIL3)

- Safe Brake Function: SBC
- Safe Direction Function: SDI
- Safe Position Function: SLP, SCA, SLI
- Safe Stop Function: STO, SS1, SS2, SOS
- Safe Velocity Function: SLS, SSM, SSR, SMS

Learn more about the safety functions on the [Kollmorgen Developer Network](#).

12.6.4 Connectivity

- CANopen
- EtherCAT
- PROFINET
- PROFIsafe and EtherCAT FSoE slave

12.7 Understanding KAS

This section provides information about the most important concepts needed to use KAS.

ⓘ IMPORTANT

To take full advantage of KAS functions, a basic understanding of automation (programming languages and motion control) is required.

12.7.1 IEC 61131-3

To create programs for the implementation of the PLC part of your application, the KAS-IDE complies with IEC 61131-3.

- This standard defines programming languages for programmable control systems.
- The KAS-IDE implements this standard to provide you with well-defined and well-known programming languages.

12.7.1.1 Data Types

Data types are defined within the common elements of IEC 61131-3.

Why Data Typing?

Data typing is implemented to define the type of any parameter used. This helps prevent errors early on in the programming phase (e.g., avoids dividing a Date by an Integer).

When you have defined whether the data is a string, a date, an integer or a 16-bit Boolean input, there is no longer any confusion, nor any conflict between different people using the textual representation (i.e., the name of the variable).

12.7.1.1.1 Different Data Types

- **Common Data Types:** Boolean, Byte, Date, Integer, Real, String, Time_of_Day, Word.
- **Derived Data Types:** Define personal data types based on the Common data types.
 - Example: Define an analog input channel as a data type and re-use it.

12.7.1.1.2 List of Data Types

Type	Prefix	Description	Values
BOOL		Boolean (bit)	<ul style="list-style-type: none"> • FALSE, TRUE • Stored in 1 byte.
BYTE		Same as "USINT" (→ p. 703).	
DINT		Signed double precision integer in 32-bits.	-2147483648 to 2147483647
DWORD		Same as "UDINT" (→ p. 703).	
INT	INT#	Signed integer in 16-bits.	-32768 to +32767
LINT	LINT#	Long signed integer in 64-bits.	
LREAL ‡	LREAL#	Double precision floating point stored in 64-bits.	<ul style="list-style-type: none"> • -1.7E308 to 1.7E308 • 14 to 15 significant digits of accuracy
LWORD		Same as "ULINT" (→ p. 703).	
REAL ‡	REAL# ††	Single precision floating point stored in 32-bits.	<ul style="list-style-type: none"> • -3.4E38 to 3.4E38 • 6 to 7 significant digits of accuracy.

Type	Prefix	Description	Values
SINT	SINT#	Small signed integer in 8-bits.	-128 to +127
STRING		Variable length string with declared maximum length. Each character is store on 1 byte (i.e., on 8-bits).	Maximum length cannot exceed 255 characters.
TIME	T# or TIME#	Time data type is used to specify a time variable. <ul style="list-style-type: none">• Accuracy is 1ms.• See "TIME" (→ p. 712).	0ms - 24hr
UDINT	UDINT#	Unsigned integer in 32-bits.	0 to +4294967295
UINT	UINT#	Unsigned integer in 16-bits.	0 to 65535
ULINT	ULINT#	Long unsigned integer in 64-bits.	
USINT	USINT#	Small unsigned integer in 8-bits.	0 to 255
WORD		Same as "UINT" (→ p. 703).	
WSTRING		Do not use! The WSTRING is not supported.	

NOTE

‡ **REAL** variables are limited to 6 digits of accuracy.

To achieve greater accuracy, a longer mantissa may be specified by prefixing **LREAL** with #.

Example: To achieve an accuracy of 20 digits for the value of Pi, rather than what **REAL** provides (3.14159), set the type to **LREAL#3.141592653589793238**.

ⓘ IMPORTANT

‡‡ **REAL** is restrictive, but because it is the default, it is recommended to explicitly declare real constants with the **LREAL#** prefix.

👉 TIP

Use **2#**, **8#**, or **16#** prefixes to specify an integer in binary, octal or hexadecimal basis, respectively.

12.7.1.1.3 Structure

A structure is a complex data type defined as a set of members.

- Members of a structure can have various data types.
 - A member of a structure can have dimensions or can be an instance of another structure.
- When a structure is defined, it can be used like other data types to declare variables.
- Members of a structure can have an initial value.
 - Corresponding members of all declared variables having this structure type are initialized with the initial value of the member.
- To specify a member of a structured variable in PLC languages, use this notation:

```
VariableName.MemberName
```

12.7.1.1.4.1 Limitation

If a member of a structure is an instance of another structure, the nested structure must be declared **BEFORE** in the list.

12.7.1.1.5 Arrays

You can declare arrays for internal variables by specifying dimension(s).

To declare an array, enter the number of elements in the **Dim.** column on the "Variables tab" (→ p. 86).

See "Create Variables" (→ p. 303) for the procedure.

Name	Type	Dim.	Attrib.
NewVar	BOOL	2,10,4	
MachineLogic			
NewVar	BOOL	[0..1,0..9,0..3]	

For a multi-dimensional array (arrays have a maximum of three dimensions), enter the number of elements for each dimension separated by commas:

- Using **2,10,4** as the 3D array:
 - The first dimension has 2 elements.
 - The second dimension has 10 elements.
 - The third dimension has 4 elements.

Arrays are accessed by variable indices.

```
myArray[myIndex1, myIndex2]
```

ⓘ IMPORTANT

All indexes are 0 based.

Example: In a single dimension array, the first element is always identified by `ArrayName[0]`.

12.7.1.2 Variables

The scopes of the variables are normally limited to the organizational unit in which they are declared, e.g. local. This means that their names can be re-used in other parts without any conflict, eliminating another source of errors, e.g. the scratchpad. If the variables have global scope, they must be declared as such. Parameters can be assigned an initial value to have the right setting at start up and cold restart.

12.7.1.2.1 Retain Variables

A retain variable is a PLC variable which:

- is non-volatile: stored in non-volatile controller memory (AKD PDMM or PCMM). When using KAS Simulator the retain variables are stored in a normal disk file.
- is known by all programs (when its content is changed, the change is propagated to all equations in which this variable is used)
- normally does not contain real-time critical data.

👉 TIP

- Retain variables are saved when you stop the PLC. The next time the PLC is started the retained values are used. Additionally, retains are auto-saved every two seconds. This applies to both the AKD PDMM and PCMM models.
- Variables stored in non-volatile memory that have changed will be updated every two seconds. Unchanged variables are not updated.

Such a variable is used to store application specific data, like for instance to count a cutting-edge cycle in order to stop for its blade replacement after a specific number of iterations.

- On an application "Start", KAS initializes the retain variables with the value stored in the NVRAM.
- On an application "Cold Start", KAS initializes the retain variables with their default value.
- If the declaration of the retain variables is different between the non-volatile memory and the project, the retain variables are also reset to their default value.

Two parameters are checked to identify if the declaration changed:

- The number of variables of each type
- The length of a STRING type variables

ⓘ IMPORTANT

The non-volatile memory size is hardware dependent. If the size of the retained variables is larger than the non-volatile storage space, an error will be logged and the data will not be stored in non-volatile memory. See "NVRAM" (→ p. 691) for more information.

For the KAS Runtime Simulator, the retained variables are saved in a file in your project repository.

NOTE

The following actions will reset retained value(s) to their Init value(s):

- Changing the type of a retain variable
- Changing the length of a string retain variable
- Changing the size of an array variable
- Changing any element of a structure variable

For more information on retained variables see "Retain Variables" (→ p. 707).

12.7.1.2.2 Variables

All variables used in programs must be declared first in the variable editor.

Each variable belongs to a group and must be identified by a unique name in its group.

12.7.1.2.3.1 Groups

A group is a set of variables.

A group refers to a physical class of variables or identifies the variables local to a program or user-defined function block.

This table lists the possible groups:

Groups	Description
%I...	Channels of an input board. <ul style="list-style-type: none"> • Variables with same data type are linked to a physical input device. • See "Variables" (→ p. 705) for more information.
%Q...	Channels of an output board. <ul style="list-style-type: none"> • Variables with same data type are linked to a physical output device. • See "Variables" (→ p. 705) for more information.
GLOBAL	Internal variables known by all programs.
PROGRAMxxx	All internal variables local to a program. The name of the group is the name of the program.

Groups	Description
"Retain Variables" (→ p. 707)	<p>Non volatile internal variables known by all programs.</p> <ul style="list-style-type: none"> • The latest values from RETAIN variables are stored from the Runtime into a file on the hard disk drive (HDD). • In case of a warm (re)start, or a cold start, the Runtime initializes the variables with these stored values. • The Runtime stores these values periodically per default, triggered every 10ms in an own, lower priority thread. • The storage can be configured using either: <ul style="list-style-type: none"> • The menu tab entry Project/Settings.../Runtime/Cycle time. • The function F_SAVERETAIN used in the program code. • If a device with zenon does not have a robust HDD, it is recommended to deactivate the periodical storage and store seldom. <ul style="list-style-type: none"> • This can be done via a manual function call.
UDFBxxx	<p>All internal variables local to a User-Defined Function Block plus its IN and OUT parameters.</p> <p>The name of the group is the name of the program.</p>

12.7.1.2.4.2 Data Type and Dimension

Each variable must have a valid data type.

- It can be either a basic data type or a function block.
 - In a function block, the variable is an instance of the function block.
- Physical I/Os must have a basic data type.
- Instances of function blocks can refer either to a standard block or to a User Defined Function Block.

If the selected data type is STRING, you must specify a maximum length. This cannot exceed 255 characters.

- See the list of "Data Types" (→ p. 702) for more information.
- See Call a Function Block for more information about using a function instance.
- Specify dimensions for an internal variable to declare "Arrays" (→ p. 703).

12.7.1.2.5.3 Name a Variable

A variable must be identified by a unique name within its parent group.

- The variable name cannot:
 - be a reserved keyword of the programming languages.
 - have the same name as a standard or C function or function block.
- A variable must not have the same name as a program or a user-defined function block.
- The name of a variable must begin by a letter or an underscore (_), followed by letters, digits, or underscore marks.
 - Two consecutive underscores in a variable name is not allowed.
- Naming is case-insensitive.
 - Two names with different cases are considered as the same.

12.7.1.2.6.4 Variable Attributes

Physical I/Os are marked as either **Input** or **Output**.

- Each internal variable can be configured as Read / Write or Read-only. See "Attributes" (→ p. 90) for more information.
 - Read-only variables can be mapped to Outputs but not to Inputs.
 - Inputs can change state and a Read-only variable cannot change its value to match the input state.
- Parameters of User-Defined Function Blocks are marked as either **IN** or **OUT**.

12.7.1.2.7 Retain Variables

12.7.1.2.8.1 What is a retain variable?

A retain variable is a PLC variable which:

- is non-volatile: stored in non-volatile controller memory (AKD PDMM or PCMM). When using KAS Simulator the retain variables are stored in a normal disk file.
- is known by all programs (when its content is changed, the change is propagated to all equations in which this variable is used)
- normally does not contain real-time critical data.

TIP

- Retain variables are saved when you stop the PLC. The next time the PLC is started the retained values are used. Additionally, retains are auto-saved every two seconds. This applies to both the AKD PDMM and PCMM models.
- Variables stored in non-volatile memory that have changed will be updated every two seconds. Unchanged variables are not updated.

Such a variable is used to store application specific data, like for instance to count a cutting-edge cycle in order to stop for its blade replacement after a specific number of iterations.

- On an application “Start”, KAS initializes the retain variables with the value stored in the NVRAM.
- On an application “[Cold Start](#)”, KAS initializes the retain variables with their default value.
- If the declaration of the retain variables is different between the non-volatile memory and the project, the retain variables are also reset to their default value.

Two parameters are checked to identify if the declaration changed:

- The number of variables of each type
- The length of a STRING type variables

IMPORTANT

The non-volatile memory size is hardware dependent. If the size of the retained variables is larger than the non-volatile storage space, an error will be logged and the data will not be stored in non-volatile memory. See "NVRAM" (→ p. 691) for more information.

For the KAS Runtime Simulator, the retained variables are saved in a file in your project repository.

NOTE

The following actions will reset retained value(s) to their Init value(s):

- Changing the type of a retain variable
- Changing the length of a string retain variable
- Changing the size of an array variable
- Changing any element of a structure variable

TIP

Retained variables should not be used as the output of Function Blocks.

Doing so may cause problems with retaining the value if the FB is executed with the Enable input off. The output structure can cause it to be conditionally updated to zero or the old value.

A work-around solution is to use a `copy (1 gain)` function to selectively enable updating the retain variable from an intermediate variable, which is the output of a function block.

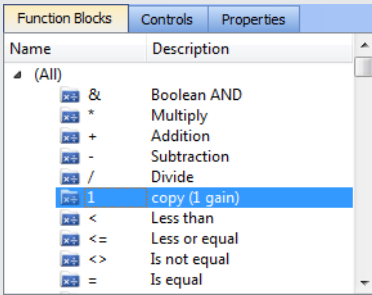

Work-around example

In this image:

- The `ReadActualPositionX` is continually reading position feedback from an axis.
 - The copy block is saving a specific value to a retain variable.
- `ActualPositionX` is the intermediate variable and `SavedPositionX` is the retain variable.

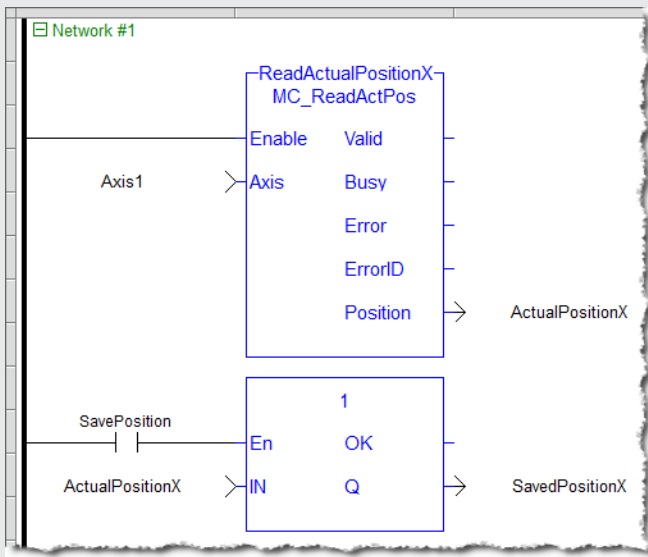

12.7.1.2.9.2 Copy a Retained Variable Value to Init Value

Once determined, retained variable values can be saved to the variable's initial value.

This allows for the KAS project to more easily be re-used for other, similar machines.

This example determines a retain variable's value and saves the value to the retain variable's initial value.

1. Run the program to determine the retain variable's value, which is FALSE.

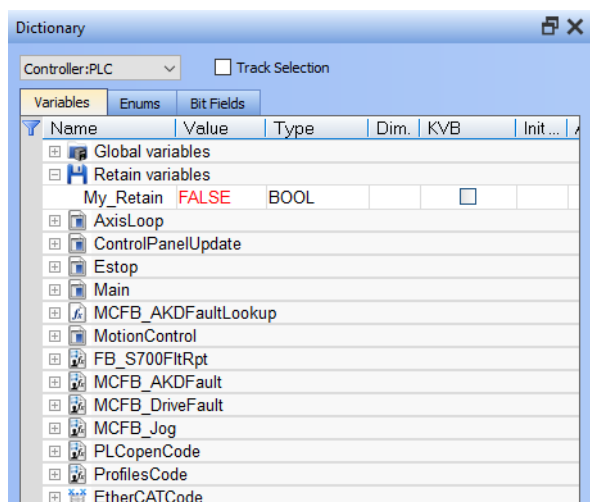

2. Right-click the variable and select **Copy variable value to init value**.

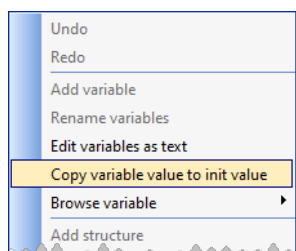

3. The Init value field is now "FALSE".

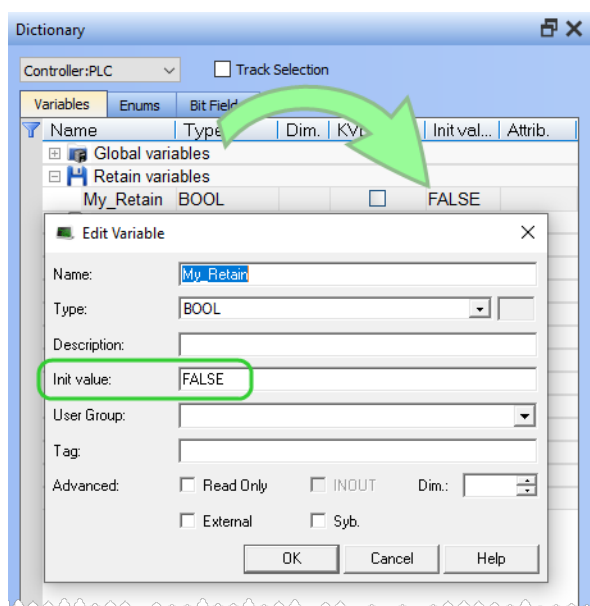

12.7.2 Limitations

The copy function has several limitations

- The menu item is only enabled under these conditions:
 - The project must be compiled and running, and the KAS-IDE is connected to the controller.
 - One or more retain variables must be selected (an individual variable or a group).

- The program must be recompiled and downloaded for this to take effect.
- Arrays and structures are not supported.

12.7.2.1 Constant Expressions

Constant expressions can be used in all languages for assigning a variable with a value.

All constant expressions have well-defined **Data Types** according to their semantics.

ⓘ IMPORTANT

If you program an operation between variables and constant expressions having inconsistent data types, it leads to syntactic errors when the program is compiled.

These are the syntactic rules for constant expressions according to possible data types:

Type	Prefix	Description
BOOL		<p>Boolean</p> <ul style="list-style-type: none"> • These are the Boolean reserved keywords: <ul style="list-style-type: none"> • TRUE • FALSE • See "Valid Constant Expressions" (→ p. 713) for an example.
DINT		<p>32-bit (default) Integer</p> <ul style="list-style-type: none"> • 32-bit integer constant expressions must be valid numbers between -2147483648 to 2147483647. • DINT is the default size for integers: such constant expressions do not need any prefix. • Use 2#, 8#, or 16# prefixes to specify an integer in binary, octal or hexadecimal basis, respectively. • See "Valid Constant Expressions" (→ p. 713) for an example.
INT	INT#	<p>16-bit Integer</p> <ul style="list-style-type: none"> • 16-bit integer constant expressions are valid integer values (between -32768 and +32767). • Must be prefixed with INT#. • All integer expressions having no prefix are considered "DINT" (→ p. 710) integers. • See "Valid Constant Expressions" (→ p. 713) for an example.
LINT	LINT#	<p>Long (64-bit) Integer</p> <ul style="list-style-type: none"> • Long integer constant expressions are valid integer values. • Must be prefixed with LINT#. • All integer expressions having no prefix are considered "DINT" (→ p. 710) integers. • See "Valid Constant Expressions" (→ p. 713) for an example.

Type	Prefix	Description
LREAL	LREAL#	<p>Double Precision Floating Point Value</p> <ul style="list-style-type: none"> • Real constant expressions must be valid numbers, must include a dot (.). • If you need to enter a real expression having an integer value, add .0 (dot zero) at the end of the number. • You can use F or E separators for specifying the exponent in case of a scientific representation. • LREAL constants are limited to 14-15 digits of accuracy. <ul style="list-style-type: none"> • Any digits after these significant digits are lost, leading to a loss of precision. • See "Valid Constant Expressions" (→ p. 713) for an example.
REAL		<p>Single Precision Floating Point Value</p> <ul style="list-style-type: none"> • REAL is the default precision for floating points: such expressions do not require a prefix. • Important: REAL is restrictive, but because it is the default, it is recommended to explicitly declare your real constants with the LREAL# prefix. • Real constant expressions must be valid numbers, must include a dot (.). • If you need to enter a real expression having an integer value, add .0 (dot zero) at the end of the number. • You can use F or E separators for specifying the exponent in case of a scientific representation. • REAL constants are limited to 6-7 digits of accuracy. <ul style="list-style-type: none"> • Any digits after these significant digits are lost, leading to a loss of precision. • See "Valid Constant Expressions" (→ p. 713) for an example.
SINT	SINT#	<p>Small (8-bit) Integer</p> <ul style="list-style-type: none"> • Small integer constant expressions are valid integer values (between -128 and +127). • Must be prefixed with SINT#. • All integer expressions having no prefix are considered "DINT" (→ p. 710) integers. • See "Valid Constant Expressions" (→ p. 713) for an example.

Type	Prefix	Description																		
STRING		<p>Character String</p> <ul style="list-style-type: none"> String expressions must be written between single quote marks (' '). The length of the string cannot exceed 255 characters. See "Valid Constant Expressions" (→ p. 713) for an example. Use these sequences to represent a special or not-printable character within a string: <table border="1"> <thead> <tr> <th>Sequence</th> <th>Description</th> </tr> </thead> <tbody> <tr> <td>\$\$</td> <td>A "\$" character</td> </tr> <tr> <td>\$'</td> <td>A single quote</td> </tr> <tr> <td>\$T</td> <td>A tab stop (ASCII code 9)</td> </tr> <tr> <td>\$R</td> <td>A carriage return character (ASCII code 13)</td> </tr> <tr> <td>\$L</td> <td>A line feed character (ASCII code 10)</td> </tr> <tr> <td>\$N</td> <td>Carriage return plus line feed characters (ASCII codes 13 and 10)</td> </tr> <tr> <td>\$P</td> <td>A page break character (ASCII code 12)</td> </tr> <tr> <td>\$xx</td> <td>Any character (xx is the ASCII code expressed on two hexadecimal digits)</td> </tr> </tbody> </table>	Sequence	Description	\$\$	A "\$" character	\$'	A single quote	\$T	A tab stop (ASCII code 9)	\$R	A carriage return character (ASCII code 13)	\$L	A line feed character (ASCII code 10)	\$N	Carriage return plus line feed characters (ASCII codes 13 and 10)	\$P	A page break character (ASCII code 12)	\$xx	Any character (xx is the ASCII code expressed on two hexadecimal digits)
Sequence	Description																			
\$\$	A "\$" character																			
\$'	A single quote																			
\$T	A tab stop (ASCII code 9)																			
\$R	A carriage return character (ASCII code 13)																			
\$L	A line feed character (ASCII code 10)																			
\$N	Carriage return plus line feed characters (ASCII codes 13 and 10)																			
\$P	A page break character (ASCII code 12)																			
\$xx	Any character (xx is the ASCII code expressed on two hexadecimal digits)																			
TIME	T# or TIME#	<p>Time of Day</p> <ul style="list-style-type: none"> Time-constant expressions represent durations that must be less than 24 hours. Expressions must be prefixed by either T# or TIME#. They are expressed as a number of: <ul style="list-style-type: none"> hours followed by h minutes followed by m seconds followed by s milliseconds followed by ms The order of units (hour, minutes, seconds, milliseconds) must be respected. <ul style="list-style-type: none"> Blank characters are not allowed in the time expression. There must be at least one valid unit letter in the expression. See "Valid Constant Expressions" (→ p. 713) for an example. 																		
UDINT/DWORD	UDINT#	<p>Unsigned 32-bit Integer</p> <ul style="list-style-type: none"> Unsigned 32-bit integer constant expressions are valid integer values (between 0 and 4294967295). Must be prefixed with UDINT#. All integer expressions having no prefix are considered "DINT" (→ p. 710) integers. 																		

Type	Prefix	Description
UINT/WORD	UINT#	Unsigned 16-bit Integer <ul style="list-style-type: none"> Unsigned 16-bit integer constant expressions are valid integer values (between 0 and +65535). Must be prefixed with <code>UINT#</code>. All integer expressions having no prefix are considered "DINT" (→ p. 710) integers.
ULINT/LWORD	ULINT#	Unsigned Long Unsigned (64-bit) Integer <ul style="list-style-type: none"> Unsigned 64-bit integer constant expressions are valid integer values. All integer expressions having no prefix are considered "DINT" (→ p. 710) integers.
USINT/BYTE	USINT#	Unsigned 8-bit Integer <ul style="list-style-type: none"> Unsigned small integer constant expressions are valid integer values (between 0 and 255). Must be prefixed with <code>USINT#</code>. All integer expressions having no prefix are considered "DINT" (→ p. 710) integers.

12.7.2.1.1 Examples

12.7.2.1.2.1 Valid Constant Expressions

These are examples of valid constant expressions.

Constant Expression	Type	Description
'hello'	Character String	Character string.
'I\$'m here'	Character String	Character string with a quote inside (I'm here).
'name\$Tage'	Character String	Character string with two words separated by a tab.
'x\$00y'	Character String	Character string with two characters separated by a null character (ASCII code 0).
0.0	REAL	0 expressed as a REAL number.
1.002E3	REAL	1002 expressed as a REAL number in scientist format.
2#1000100	DINT	DINT integer in binary basis.
8#34712	DINT	DINT integer in octal basis.
16#abcd	DINT	DINT integer in hexadecimal basis.
123456	DINT	DINT (32-bit) integer.
FALSE	BOOL	FALSE Boolean expression.
INT#2000	16-bit Integer	16-bit integer.
LINT#1	Long (64-bit) Integer	Long (64 bit) integer having the value 1.
LREAL#1E-200	Double Precision Floating Point Value	Double precision real number.
SINT#127	Small (8-bit) Integer	Small integer.
T#1h123ms	Time of Day	TIME value with some units missing.
T#23h59m59s999ms	Time of Day	Maximum TIME value.
TIME#0s	Time of Day	Null TIME value.
TRUE	BOOL	TRUE Boolean expression.

12.7.2.1.3.2 Invalid Constant Expressions

These are examples of errors in constant expressions:

Invalid Constant Expressions	Description
'I'm here'	Quote within a string with "\$" mark omitted.
1a2b	Basis prefix ("16#") omitted.
1E-200	"LREAL#" prefix omitted for a double precision float.
BooVar := 1;	0 and 1 cannot be used for Booleans.
hello	Quotes omitted around a character string.
T#12	Time unit missing.

NOTE
 There are pre-defined constants.
 See "Use the Defines List" (→ p. 311), "Internal Defines" (→ p. 312), and "Global Defines" (→ p. 313) for more information.

12.7.2.2 Program Organization Units

Within IEC 61131-3, the "Functions" (→ p. 714), "Function Blocks" (→ p. 715), and "Programs" (→ p. 716) are called Program Organization Units (POU).

In addition to the IEC standard, you can write you own code as either a sub-program or UDFB.

Types	IEC 61131-3	Written by end-user
Basic functions (has no memory)	"Functions" (→ p. 714)	"Programs" (→ p. 716) / "Sub-programs" (→ p. 716)
Instantiated functions (keep track of the past)	"Function Blocks" (→ p. 715) (FB)	"User-Defined Function Blocks" (→ p. 717) (UDFB)

12.7.2.2.1 Differences between Functions and Function Blocks

- Functions are expected to complete in one cycle.
- Function Blocks can take several cycles to complete.

12.7.2.2.2.1 Description of FB Operation

Rather than halt the application or waiting for operations to complete, the FB typically gives control back to the application but does not set its **Done** output.

12.7.2.2.3.2 Examples of Operations Overrunning the Cycle Duration

- A motion command to move from one location to another can take several cycles to complete.
- Operations like reading/writing to files or reading and writing over TCP/IP can also take several cycles to complete.

12.7.2.2.4.3 Operation Sequence

1. When an FB is called, it starts an operation and possibly does not complete it.
2. The FB is called in the next cycle and it checks to determine if the operation is done.
3. If it is done, it sets the **Done** output.
 If not, it continues on.
4. Now the application knows that the operation is complete and can do what ever other processing it needs based on the FB being done.

12.7.2.2.5 Functions

IEC has defined standard functions and also allows you to create your own functions (called user-defined functions). Typically, functions take several inputs and return a single output as the result of processing.

- Standard functions are for example ADD (addition), ABS (absolute), SIN (sine), COS (cosine), GT (Greater Than),....
- User-defined functions, as in the following example, can be used repeatedly once defined.

```
FUNCTION SIMPLE_FUN : REAL
  VAR_INPUT
    A, B : REAL;
    C : REAL := 1.0;
  END_VAR
  SIMPLE_FUN := A*B/C;
END FUNCTION
```

12.7.2.2.6 Function Blocks

Function Blocks (FBs) take several inputs and return a group of values as the output as the result of processing.

Function Blocks are the equivalent to Integrated Circuits (IC), representing a specialized control function. They are specified at such a level that you quickly recognize the functionality of the function block and specifically what happens if it is activated or connected to other blocks in a sequence of motion commands.

They contain data as well as an algorithm, so they can keep track of the past (which is one of the differences from Functions). They have a well-defined interface and hidden internals, like an IC or a black box. The user only sees the interface, being the inputs and outputs. The code itself is hidden.

Function Blocks can be used in any of the IEC languages. In an SFC program, function blocks can be part of a step or transition created in FFLD, FBD, IL, and ST.

Once defined, they can be used repeatedly, in the same program, different programs, or even different projects. This makes them highly re-usable.

There are predefined function blocks (e.g., timers, counters, or triggers) and additional function blocks that can come from libraries produced by you or other suppliers (e.g., a temperature control-loop or PID).

Example of Function Blocks

- The function block is based on the programming language function block Diagram and has the name Hysterisis.
- It has three inputs (XIN1, XIN2 and EPS) of datatype REAL on the left, and one output (called Q) of type BOOL on the right-hand side.

TIP

Input names are not very usable; use meaningful names.

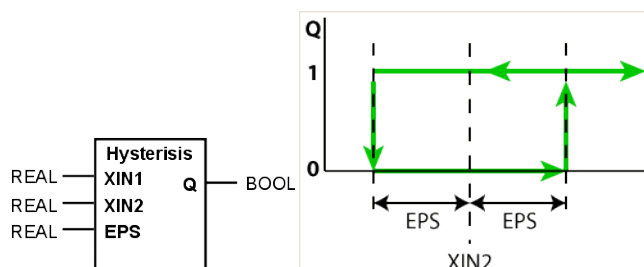

Internally, the FB contains this body code:

```
FUNCTION_BLOCK HYSTERISIS
  VAR_INPUT
```

```

        XIN1, XIN2 : REAL;
        EPS : REAL;  (* Hysterisis ban *)
END_VAR
VAR_OUTPUT
    Q : BOOK := 0
END_VAR
IF Q THEN
    IF XIN1 < ( XIN2 - EPS ) THEN
        Q := 0 (* XIN2 decreasing *)
    END_IF;
    ELSIF XIN1 > ( XIN2 + EPS ) THEN
        Q := 1; (* XIN2 increasing *)
    END_IF;
END_FUNCTION_BLOCK

```

In this example, the body code is written in the Structured Text language:

- The first part deals with the data structure.
- The second with the algorithm.
- No additional data is used.

Whatever name was used for this local data inside the body does not conflict with matching names in other functions, function blocks, or with global expressions. This example of data encapsulation removes a major source of errors.

12.7.2.2.7 Programs

With the above-mentioned basic building blocks, a program can be seen as a network of functions and function blocks. Each of them being written in any of the defined programming languages.

TIP

Programs and Subprograms can be reordered by drag-and-drop. Dragging an item up the list places it above the program you drop it on, while dragging down places it below.

12.7.2.2.8.1 Sub-programs

The list of programs is completed with "Sub-programs". Sub-programs are written in FBD, FFLD, ST or IL languages, and can be called by the programs of the application. Input and output parameters plus local variables of a sub-program are declared in the variable editor as local variables of the sub-program.

- A function type sub-program can call another function type subprogram.
- A UDFB type sub-program can call another UDFB type subprogram or a function type subprogram

Unlike UDFB, local variables of a sub-program are not instantiated. This means that the sub-program always works on the same set of local variables. Local variables of a sub-program keep their value among various calls. The code of a sub-program is not duplicated when called several times by parent programs.

A sub-program cannot have more than 32 input parameters or 32 output parameters.

A good programming practice is to break up your programs into smaller modules.

See also "Application Software Structure - Definitions" (→ p. 624).

12.7.2.2.9.2 Program Guidelines

An application is a list of programs. Programs are executed sequentially within the target cycle, according to the following model:

```

Begin cycle
| exchange I/Os
| execute first program
| ...
| execute last program
| wait for cycle time to be elapsed
End Cycle

```

Programs are executed according to the order defined by the user. All SFC programs must be grouped (it is not possible to insert a program in FBD, FFLD, ST or IL between two SFC programs). Each program is entered using a language chosen when the program is created. Possible languages are Sequential Function Chart (SFC), Function Block Diagram (FBD), Free Form Ladder Diagram (FFLD), Structured Text (ST) or Instruction List (IL). The maximum number of programs in an application is 32767.

12.7.3 Program Name

Programs must have unique names. The name cannot be a reserved keyword of the programming languages and cannot have the same name as a standard or "C" Function or function block. A program must not have the same name as a declared variable. The name of a program must begin by a letter or an underscore ("_") mark, followed by letters, digits or underscore marks. It is not allowed to put two consecutive underscores within a name. Naming is case-insensitive. Two names with different cases are considered as the same.

12.7.4 Child SFC Programs

You can define a hierarchy of SFC programs, entered as a tree in the list of programs. A child program is controlled within action blocks of the parent SFC program.

TIP

Even if you do not want to split your FFLD program, at least separate FFLD from SFC. Simply make a sub-program in FFLD called from the SFC step, and keep only the state machine in the SFC program. This makes everything simpler and more comfortable for editing and debugging.

12.7.4.0.1.1 Program Limitations

When creating your application you have to consider the following important limitations.

For **SFC** programs:

- Actions in SFC steps cannot be more than 32kB
- Condition in SFC transition cannot exceed 32kB
- Total PLC code size of the program cannot exceed 64kB

For **FFLD** programs:

- Width of any network is limited to 255 columns
- Height of any network is limited to 255 rows

For any program, sub-program or UDFB written in **other** languages:

- Jump limit is 64kB
For example, in a Free Form Ladder program, if you create a UDFB or program which is over 64kB and then decide to add a jump to label in the first network to the last network, this jump reaches the limit.
- Total PLC code size of the program, sub-program or UDFB cannot exceed 64kB

12.7.4.0.2 User-Defined Function Blocks

The list of programs is completed with "User-Defined Function Blocks" (UDFBs). UDFBs are described using SFC, FBD, FFLD, ST or IL languages, and can be used as other function blocks in the programs of the

application. Input and output parameters plus private variables of a UDFB are declared in the variable editor as local variables of the UDFB.

There is no restriction using any operation in a UDFB. A UDFB can call standard functions and function blocks.

A UDFB can call another UDFB. Note that the called UDFB must be declared before the calling one in the program list.

Each time a UDFB is instantiated, its private variables are duplicated for the declared instance. The code of the UDFB is duplicated on each call in parent programs. This leads to higher performances at run-time, but consumes code space. It is recommended to package small algorithms in UDFBs. Large parts of code must be managed in programs.

12.7.4.1 Programming Languages

In the IEC 11631 standard, syntax and semantics of the programming languages have been defined, leaving no room for variance. Once you have learned them, you can use a wide variety of systems based on this standard.

The languages consist of these textual and graphical language versions:

Textual:

- Instruction List (IL)
- Structured Text (ST)

Graphical

- Sequential Function Chart (SFC)
- Free Form Ladder Diagram (FFLD)
- Function Block Diagram (FBD)

All the languages are interlinked and provide a common suite. The choice of programming language depends on:

- the programmer's background
- the problem at hand
- the level of describing the problem
- the structure of the control system
- the interface to other people / departments

12.7.4.1.1 Sequential Function Chart

Sequential Function Chart (SFC) graphically describes the sequential behavior of a control program. It is derived from Petri Nets.

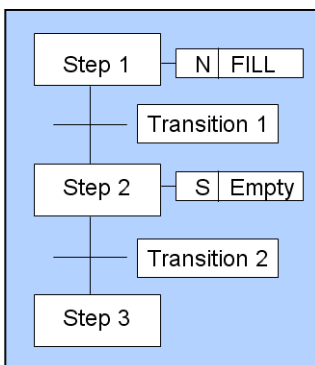

SFC organizes the internal structure of a program and helps to deconstruct a control problem into manageable parts, while maintaining the overview.

SFC consists of steps, linked with Action Blocks and Transitions.

- Each step represents a particular state of the systems being controlled.
- A transition is associated with a condition, which, when true, causes the step before the transition to be deactivated, and the next step to be activated.

- Steps are linked to action blocks, performing a specific control action.
- Each element can be programmed in any of the IEC languages, including SFC itself.

12.7.4.1.2.1 Alternative and Parallel Sequences

You can use alternative sequences and even parallel sequences, like those commonly required in batch applications.

Example: One sequence is used for the primary process and the second for monitoring the overall operating constraints.

In this image, parallel sequences are also possible:

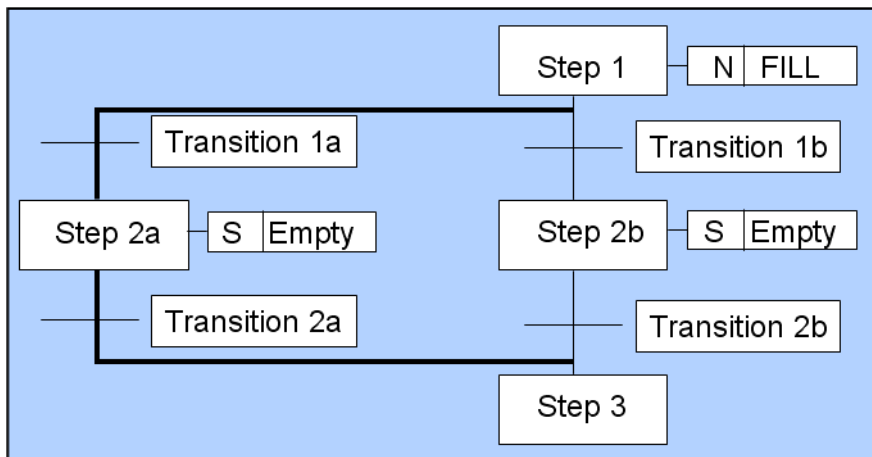

Figure 14-1: Example of a Parallel Sequence in SFC

From Step 1, it either goes to Step 2a or Step 2b, depending on which of the transition conditions is met. Both conditions need to exclude each other.

12.7.4.1.3 Structured Text

Structured Text (ST) is a very powerful, high-level language with its roots in ADA, Pascal, and “C”. It contains all the essential elements of a modern programming language, including selection branches (IF-THEN-ELSE and CASE OF) and iteration loops (FOR, WHILE and REPEAT).

These elements can also be nested. It can be used for the definition of complex function blocks, which can be used within any of the other languages.

12.7.4.1.4 Function Block Diagram

Function Block Diagram (FBD) is very common to the process industry. It expresses the behavior of functions, function blocks, and programs as a set of interconnected graphical blocks, as in electronic circuit diagrams. It looks at a system in terms of the flow of signals between processing elements.

12.7.4.1.5 Free Form Ladder Diagram

Free Form Ladder Diagram (FFLD) is based on the graphical presentation of Relay Ladder Logic.

12.7.4.1.6 Instruction List

Instruction List (IL) is the European counterpart of FFLD. As textual language and looks like Assembler.

12.7.4.2 Alias Definitions

The compiler supports the definition of aliases.

- An alias is a unique identifier used in programs to replace another text.
 - Definitions are typically used to replace a constant expression and facilitate the maintenance of programs.
 - See usage in (→ # 311, Use the Defines List) for more information.

There are three levels of definitions:

- Common to all the projects present on your machine
- Global to all programs within your project
- Local to one program

Local definitions are edited together with the corresponding program.

- Definitions are entered in a text editor.
 - Each definition must be entered on one line of text following this syntax:

```
#define Identifier Equivalence (* comments *)
```

Examples

```
#define OFF    FALSE           (* redefinition of FALSE constant *)
#define PI     3.14            (* numerical constant *)
#define ALARM (bLevel > 100) (* complex expression *)
```

- You can use a definition within the contents of another definition.
 - The definition used in the other one must be declared first.

Example

```
#define PI      3.14
#define TWOPI  (PI * 2.0)
```

- A definition can be empty

Example

```
#define CONDITION
```

The defined word can be used for directing the Conditional Compiling directives.

TIP

You can enter `#define` lines directly in the source code of programs in IL or ST languages.

The use of definitions can disturb the program monitoring and make error reports more complex. It is recommended to restrict the use of definitions to simple expressions that do not risk creating a misunderstanding when reading or debugging a program.

Word	Description
<code>_DATE_</code>	Date stamp of compiling expressed as a string constant expression. Format is: Year/Month/Day-Hours-Minutes.
<code>_MACHINE_</code>	Name of the machine where compiling is run, expressed as a string constant expression.
<code>_USER_</code>	Name of the user where compiling is run, expressed as a string constant expression.

12.7.4.2.1 Example

This ST program sets variables declared as `STRING(255)`:

```

strDate := __DATE__;
strMachine := __MACHINE__;
strUser := __USER__;
strProject := __APPNAME__;

```

Result:

```

strDate is '2007/11/25-10:45'
strMachine is 'LaptopJX'
strUser is 'John'

```

12.7.4.3 Exception Handling

The compiler is used to write your own exception programs for handling particular system events.

These are the exceptions:

- "Division By Zero Exceptions" (→ p. 721).
- "Shutdown Exceptions" (→ p. 721) (after the last cycle).
- "Startup Exceptions" (→ p. 722) (before the first cycle).

NOTE

Exception handling is supported for both Normal and Optimized [PLC code generation](#).

- In the sub-program that handles the exception you can perform any safety or trace operation.
- Then, select between these possibilities:
 - Return without any special call.
 - In this case the standard handling is performed:
 - A system error message is generated.
 - The result of the division is replaced by a maximum value and the application continues.
 - Call the FatalStop function.
 - The runtime then stops immediately in Fatal Error mode.
 - Call the CycleStop function.
 - The runtime finishes the current program and then turns in "cycle setting" mode.

Handlers can also be used in DEBUG mode for tracking the bad operation.

- Put a breakpoint in the handler.
 - When stopped, the call stack shows the location of the division in the source code of the program.

12.7.4.3.1 Division By Zero Exceptions

You can write your own exception program for handling the **Division by zero** exception.

In this procedure, you must follow for setting an exception handler:

1. Create a new sub-program without any parameter that will handle the exception.
2. In the editor of [global defines](#), insert this line:

```
#OnDivZero SubProgramName
```

12.7.4.3.2 Shutdown Exceptions

You can write your own exception program to be executed after the last application cycle when the runtime system is cleanly stopped.

1. Create a new main program that handles the exception.
It cannot be an SFC program.
2. In the editor of [global defines](#), insert this line:

```
#OnShutdown ProgramName
```

⚠ WARNING

You cannot put breakpoints in the Shutdown program.

12.7.4.3.3 Startup Exceptions

You can write your own exception program to be executed before the first application cycle is executed.

1. Create a new main program that will handle the exception.
It cannot be an SFC program.
2. In the editor of [global defines](#), insert this line:

```
#OnStartup ProgramName
```

⚠ WARNING

The program is executed before all other programs within the first cycle.
This implies that the cycle timing can be longer during the first cycle.
You cannot put breakpoints in the Startup program.

12.7.5 Motion Concepts

12.7.5.1 Introducing Motion

12.7.5.1.1 Motion Control Main Functions

To ensure accurate positioning and movement, motion control consists of the two following main parts:

- Setpoint generation
- Regulation

12.7.5.1.2.1 Setpoint Generation

- This consists of generating a trajectory defined by **position versus time**.
- It is purely logical and does not relate to the physical world.

12.7.5.1.3.2 Regulation

Even using the very best drives, you cannot maintain accurate positioning without a feedback loop.

- The regulation consists of following the generated position settings using classical feed-forward or feedback control-loops (by means of PID).
 - See "How do I implement feedback?" (→ p. 831) for more information.
- Regulation is the part which takes care of the physical world of making moving motors.

These two functions can be located on the same hardware (as in a "stand-alone" servo drive) or on two separate hardware devices, linked together by a fieldbus.

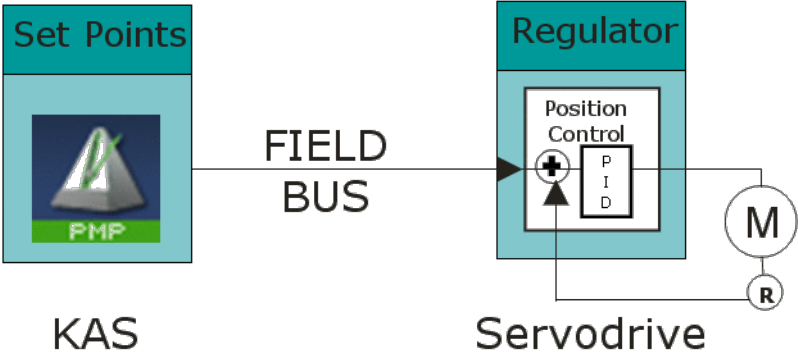

Figure 14-2: Regulation with Remote Drive

12.7.5.1.4 Single and Multi-Axis Motion

In **Single-Axis**, one setpoint generator is linked to one axis.

Multi-Axis motion consists of synchronizing several axes linked to a common motion source.

This source can be external (e.g., a physical motor (called master) or an internal profile generator (called virtual master)) as shown in this Figure: "**Multi-Axis Driven by a Virtual Master**" image:

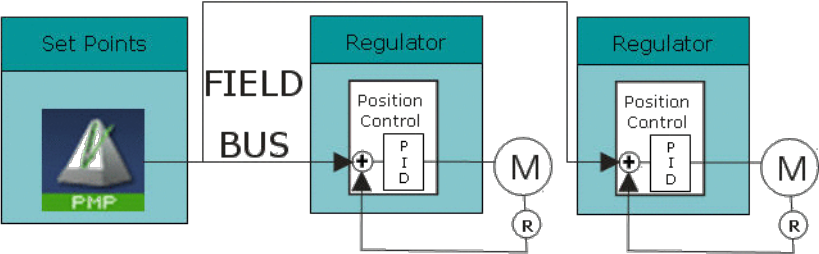

Figure 14-3: Multi-Axis Driven by a Virtual Master

12.7.5.1.5 Hardware Organization of Motion Functions

A complete motion control chain is made of two main parts that can be subdivided into several more basic functionalities. Depending on your hardware system configuration, each of these elementary functions can theoretically be embedded in different hardware modules.

This image is one of the possible configurations:

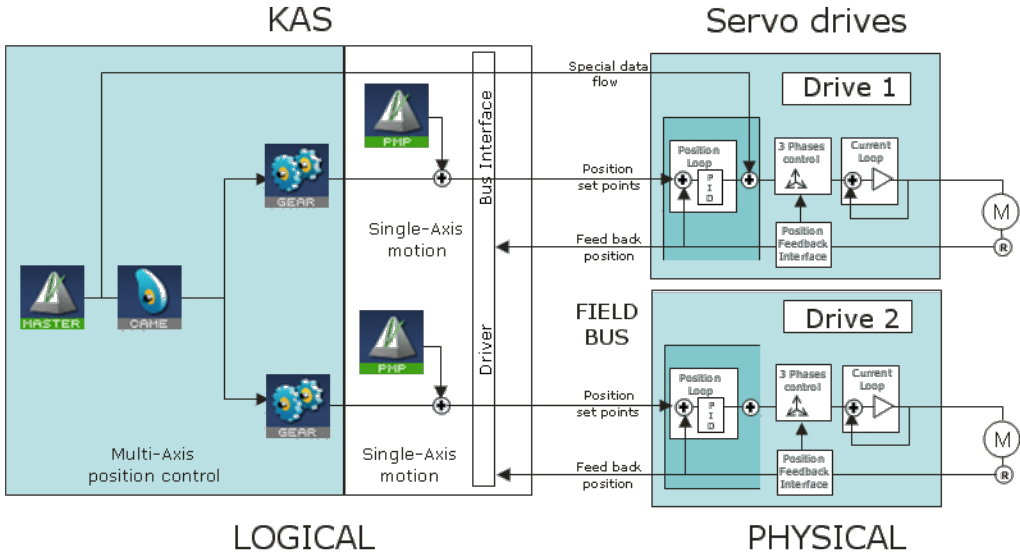

Figure 14-4: Hardware Organization of Motion Functions

The scope of Kollmorgen Automation Suite is to:

- Manage all the logical parts of the motion control.
- Ignore the physical aspects (which are handled by the hardware).

To make the link between the logical and physical worlds, KAS includes some components that acts as interface.

We no longer consider regulation and the physical world. Only "Setpoint Generation" (→ p. 722) is taken into account.

12.7.5.1.6 Motion Profile

In motion control, a common need is to move a system from one steady position to another (point-to-point motion).

Following the fastest possible motion within an allowed maximum value for speed, acceleration, and jerk, results in a third-order motion profile as shown in this image:

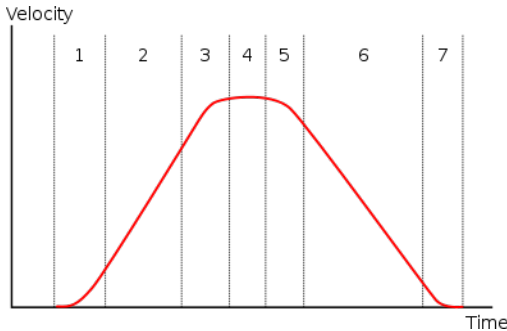

Figure 14-5: Third-order motion profile

The motion profile consists of a maximum of seven phases defined by:

- Acceleration increase with maximum positive jerk.
- Constant maximum acceleration (zero jerk).
- Acceleration decrease, approaching the desired maximum velocity with maximum negative jerk.
- Constant maximum speed (zero jerk, zero acceleration).
- Deceleration increase, approaching the desired deceleration with maximum negative jerk.
- Constant maximum deceleration (zero jerk).
- Deceleration decrease, approaching the desired position at zero velocity with maximum positive jerk.

If the initial and final positions are sufficiently close together, the maximum acceleration or maximum velocity may never be reached.

12.7.5.1.7 KAS Touch Probe and Fast Input Overview

This page provides links to KAS documentation sections which are helpful in configuring and using the Touch Probe feature, also known as "fast inputs" or "capture engine".

12.7.5.1.8.1 Configuration

12.7.6 Drive Configuration

- **AKD:** AKD Support With MC_TouchProbe
- **AKD2G:** AKD2G Support With MC_TouchProbe
- **EtherCAT Configuration for Drives:** The correct input PDOs must enabled for touch probes to work correctly. New KAS projects enable the PDOs needed for most touch probe applications. Some applications need special configurations. Those configurations can be changed here: "PDO Selection/Mapping tab" (→ p. 340)

12.7.7 Pipe Network Configuration

- MLAxisCfgFastIn
- MLTrigSetEdge

12.7.8 PLCopen Configuration

- MC_TouchProbe
- MC_Reference
- MC_MachRegist

12.7.8.0.1.1 List of Function Blocks and Pipe Blocks

12.7.9 PLCopen Function Blocks

I/O

- MC_TouchProbe

Reference

- MC_Reference

Registration

- MC_MachRegist
- MC_MarkRegist
- MC_StopRegist

12.7.10 Pipe Network Blocks

Motion / Pipe Network - Axis

- MLAxisCfgFastIn
- MLAxisIsTriggered
- MLAxisRstFastIn

Motion / Pipe Network - Trigger

- MLTrigClearFlag
- MLTrigInit
- MLTrigIsTriggered
- MLTrigReadDelay
- MLTrigReadPos
- MLTrigReadTime
- MLTrigSetEdge
- MLTrigWriteDelay

12.7.10.1 Pipe Network or PLCopen

Using KAS these are the ways to generate motion functions and motion profiles:

- "Pipe Network" (→ p. 725)
- "PLCopen" (→ p. 726)

12.7.10.1.1 Pipe Network

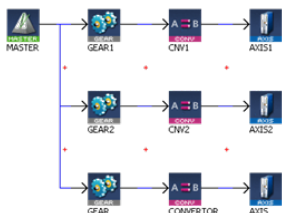

The Pipe Network is used to create a high-performance motion algorithm which is tightly integrated to the PLC program with motion library function blocks.

- For high-performance, complex, or synchronized multi-axis applications, the pipe concept in KAS provides a simple conversion of mechanical applications into a graphical representation of application elements and the process flow.
- This format makes it easy to understand, program, and update the motion profiles and positional relationships.
- The KAS application begins with the creation of a Pipe Network structure linking Master objects (source) to Axes objects (destination).
 - This includes the definition of specific transformer motion profiles.
 - This structure is controlled from the PLC application using dedicated function blocks in the Motion Library.
- To be able to use pipes correctly, it is necessary to consider the "Pipe Network Concept" (→ p. 727).

12.7.10.1.2 PLCopen



- Standard function blocks can be used and directly incorporated into the PLC application.
- Programming of motion is done using standard MC function blocks that can be incorporated in [single-axis](#) or [multi-axis](#) applications.
- See the [PLCopen Web site](#) for more information.

12.7.10.1.3 Pipe Network and PLCopen Motion Engine Differences

This table outlines some of the main feature differences between the Pipe Network and the PLCopen motion engines and their associated function blocks.

Topic	Pipe Network	PLCopen
Axis setup method	Includes in the Pipe Network Axis block properties. See Motion / Pipe Network - Axis.	Part of Axis definition screen in the Project tree.
Does a Function block requires instantiation?	No except for MLAxisStop.	Most require it.
Function block format	Begins with ML (e.g., MLAxisRel)	Begins with MC_ (e.g., MC_MoveRelative)
Function block standard input format	Requires additional function blocks to define motion parameters (e.g., speed, accel, decel, etc.)	Includes standard set of inputs to define motion (e.g., speed, accel, decel, etc.)
How the Axis name is setup?	Automatically done as part of Pipe Network Axis block properties. See Motion / Pipe Network - Axis.	1. Create an instance of a Axis_Ref variable structure in the dictionary. 2. Assign an axis number to it in a PLC program.
Is there additional motion editor?	Yes (Pipe Network editor)	No
Method to start execution	Most are level triggered.	Most are edge triggered.
Motion buffering	Execution of multiple motion commands in a row is handled by the programmer.	Function blocks have built in buffering modes.

Topic	Pipe Network	PLCopen
Motion execution status for function block executing motion	Use the MLMotionStatus function block.	Each function block includes a standard set of outputs for motion status.
Motion jerk reduction	Primarily available by adding cams to the Pipe Network.	Function blocks have jerk reduction input.

12.7.10.2 Pipe Network Concept

To introduce the Pipe Network concept, we can use a mechanical analogy.

In this figure, the mechanical system is composed of three-axes and driven by one motor.

- All axes are connected to the motor through shafts, gears and cams.
- When the motor is in motion, all axes are moving synchronously.
- The speed relation between the Master and the Axis is achieved by using a mechanical Gear.
- A mechanical cam is used to get linear motion from a rotating wheel.

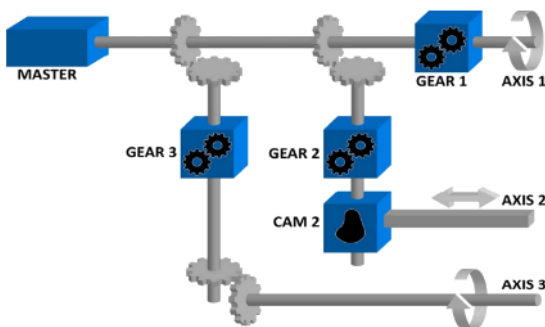

Figure 14-6: Mechanical System

The Pipe Network in this figure corresponds to the mechanical system described above. The pipe concept is a one-to-one translation of a mechanical system into the logical world.

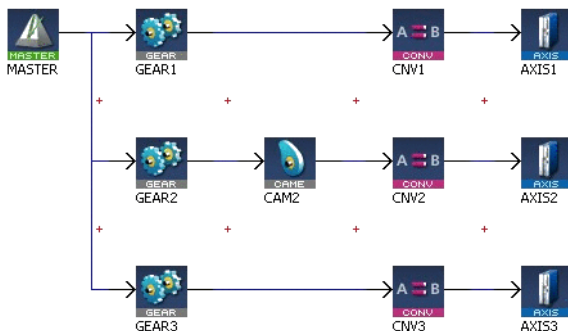

Figure 14-7: Pipe Network Structure

In our Pipe Network, the analogy is:

- The main motor of the mechanical machine becomes a Virtual Master Pipe Block.
- The gear boxes becomes Gear Blocks.
- The mechanical cam becomes a Cam Block.
- The axes becomes Axis Blocks.

The Pipe Network concept allows motion engineers to define, in a very natural way, the physical relationships between the different axes of their machine.

This modular approach provides a solution for almost any multi-axis requirements. It remains open for new, additional functions that can be required in the future.

12.7.10.2.1 Pipe Network

To control the machine application with multi-axes that are dynamically interconnected, you can design several pipes with the KAS-IDE to create the global Pipe Network. See Figure: "Pipe Network Structure" for more information.

Relationships between the axes are developed and connected graphically, allowing you to visualize how the machine functions. Each horizontal flow is considered as a separate pipe. In the application below there are three pipes.

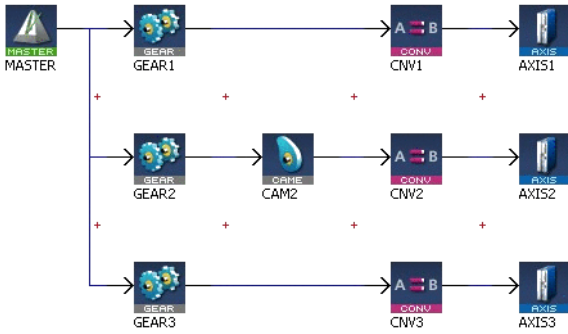

- The Pipe Network can be edited at any time.

NOTE

You do not have to finalize the Pipe Network before writing a PLC program. You must compile the project to have the latest Pipe Network information available in the PLC program editor.

- Program code does not have to be written when setting up the foundation of a program because the parameters are entered in set-up screens.

IMPORTANT

Pipe Network code is generated automatically by the compiler. Do not try to modify it.

- In the programs, define activation or deactivation statements to install or remove pipes and Pipe Blocks.
 - This allows the dynamic adjustment of the machine behavior depending on the result.
- The Pipe Network contains a full library of single-axis motion commands for sections of an application where an axis operates independently.

12.7.10.2.2 Pipe Structure

A pipe is a set of Pipe Blocks linked together (where position flows from one Pipe Block to the next). The general structure of a pipe is:

- Start with an input Pipe Block (source).
- Optionally followed by transformer Pipe Blocks.
- Followed by an output Pipe Block (converter).
- Finish with the destination Pipe Block.

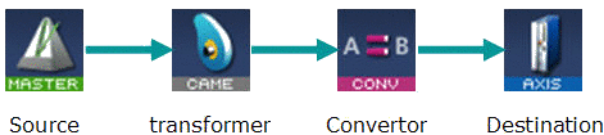

Figure 14-8: Typical Pipe Structure

TIP

Jerk may ultimately cause a jerk in motor motion when a cam block is applied to the upstream pipe network positions.

To avoid jerk in the pipe network, the potential position offset between the cam's first point and the input to the cam block must be taken care of in the application program by setting a cam offset or another method.

NOTE

This image shows an option for velocity instead of position using a differential Pipe Block:

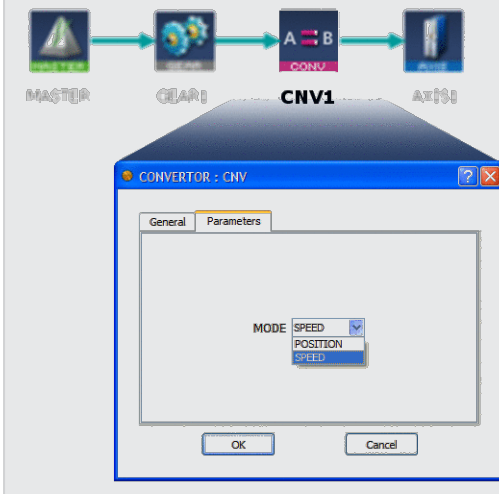

See (→ # 158, Adding Motion) for more information about the different kinds of Pipe Blocks.

12.7.10.2.3 Pipe Block

Pipes are built using logical entities called Pipe Blocks.

- A Pipe Block:
 - Is an object whose purpose is to modify a flow of values with strict time constraints.
 - Normally has both input and output flows of values.
 - See Pipe Block Descriptions.

This table has the different Pipe Blocks, based on their functions:



Function	Description
Destination	Models a physical axis of the machine.
Input (source)	Works as generator of values: <ul style="list-style-type: none"> • Sample external source objects. • Create a discrete flow of values as an input to the pipe.
Output (convertor)	Block that can end a pipe: <ul style="list-style-type: none"> • Convert the incoming values from user units to correct system units for the destination objects.
Transformer	<ul style="list-style-type: none"> • Apply a specific algorithm to the input value to produce their output. <ul style="list-style-type: none"> • Transformations can be linear or complex (e.g., cam). • Can create events depending on the incoming values.

12.7.10.2.4.1 Pipe Network - List of Pipe Blocks

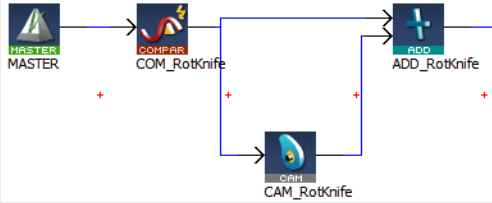
This table provides a description of each Pipe Block.

Pipe Block	Function	Link to Pipe Block Function Overviews	Description
Adder	Mathematical	Motion / Pipe Network - Adder.	Adds two data flows. Use an Adder block with a Cam block to dynamically change the distance moved during each period (or modulo) of motion.
Axis	Destination	Motion / Pipe Network - Axis	Models the link from the Pipe Network to a physical axis.
Cam	Modification	Motion / Pipe Network - CAM Profile	Use a Cam Pipe Block to optimize the motion profile. Applies a cam table (also called Cam Profile) to the input data flow.
Comparator	Event-driven	Motion / Pipe Network - Comparator	<p>Monitor the input data flow and detects the crossing of a particular value. By tracking the position at one point of the Pipe Network, you can use a Comparator Pipe Block to synchronize when code is executed in a PLC application program.</p> <p>Click to view an example</p> <p>This example shows the changing of the offset move by changing the amplitude (or offset) of the Cam Pipe Block.</p>  <p>In a PLC application program, the:</p> <ul style="list-style-type: none"> • MLCompWriteRef function block is used to arm the comparator block. • MLCompCheck function block is used to check the position. • By using condition statements in a user program, specific actions (e.g., changing the move distance of the offset) can then be taken. <p>Another example shows the use of a Comparator Pipe Block to determine if a high-speed input is within the acceptable position range.</p>
Convertor	Output	Motion / Pipe Network - Convertor	Converts input data flow to a position and forwards it to an axis.

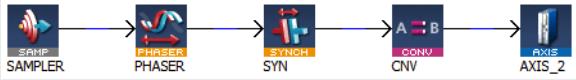
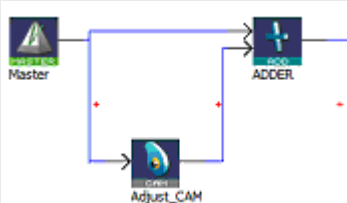
Pipe Block	Function	Link to Pipe Block Function Overviews	Description
Delay	Event-driven	Motion / Pipe Network - Delay	<p>Delay the data flow during some cycles. Use a Delay Pipe Block to delay the flow of position through a Pipe Network.</p> <ul style="list-style-type: none"> • Example: Place it before a Trigger block in a pipe which is not connected to a drive. • There is a delay of five servo update cycles between the dynamic position in the Pipe Network and the triggering of a high-speed digital input.
Derivator	Mathematical	Motion / Pipe Network - Derivator	Applies a derivation on the input data flow.
Gear	Modification	Motion / Pipe Network - Gear	<p>Applies a gearing ration on the input data flow. Use a Gear Pipe Block to perform electronic gearing.</p> <p>This block allows gear ratios and the slope of the gear change to be initially set, then changed from in the application program.</p>
Integrator	Mathematical	Motion / Pipe Network - Integrator	Integrates the input data flow.
Master	Input	Motion / Pipe Network - Master	<p>Virtual master generating values (position) at each cycle.</p>  <p>Use a Master Pipe Block to create a virtual master to link two or more axes.</p> <ul style="list-style-type: none"> • The Profile generator in the Master block is trapezoidal. <ul style="list-style-type: none"> • If a parabolic type profile is required, use a PMP Pipe Block. • If the master is an external encoder or another axis, use the Sampler Pipe Block.
Phaser	Modification	Motion / Pipe Network - Phaser	<p>Applies a phase offset to the input. Use a Phaser Pipe Block to:</p> <ul style="list-style-type: none"> • Perform a dynamic phase adjustment inside the Pipe Network. • Phase-advance or phase-retard a position as required to synchronize different motion elements on a machine.

Pipe Block	Function	Link to Pipe Block Function Overviews	Description
Sampler	Input	Motion / Pipe Network - Sampler	<p>Samples external value (encoder, resolver, PLC variable etc.)</p>  <p>Use a Sampler Pipe Block to:</p> <ul style="list-style-type: none"> • Read an external encoder as an input signal into the Pipe Network. • Directly read the actual position of another axis.  <p>Cam Profiles are created using the "Cam Profile Editor" (→ p. 444).</p>
Synchronizer	Event-driven	Motion / Pipe Network - Synchronizer	<p>Starts and stops a sub-pipe in a controlled way.</p> <ul style="list-style-type: none"> • Use a Synchronizer Pipe Block to synchronize two axes. • This Pipe Block is useful in applications where it is necessary to start the motion of a second axis and sync to the first.
Trigger	Event-driven	Motion / Pipe Network - Trigger	<p>Computes the local pipe value from the timestamp of a Fast Input event.</p>  <ul style="list-style-type: none"> • Use a Trigger Pipe Block to read the position when a high-speed input is triggered on the machine. • The trigger block allows you to catch the position at a particular location in the Pipe Network, as required by the application.

12.7.10.2.5.2 Change the Information Flow from Position to Velocity

Use the **Convertor** Pipe Block to change the Pipe Network flow of information from position to velocity.

This block is normally set up to a Receive position, so it must be changed to receive the expected input signal type shown in this image:



Figure 14-9: Change the Mode of Converter Block to SPEED (not POSITION mode).

12.7.10.2.6 Axis Pipe Block

The Axis pipe block is the link between the logical and physical worlds, managing position data for a physical or simulated axis.

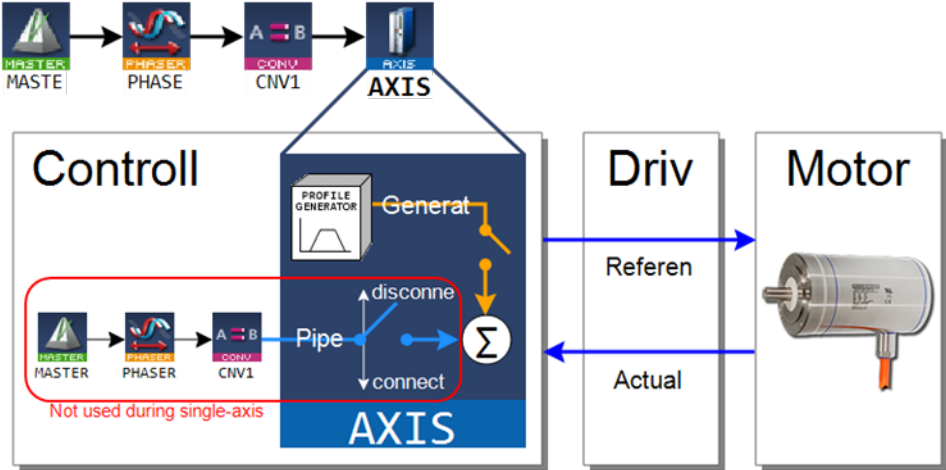
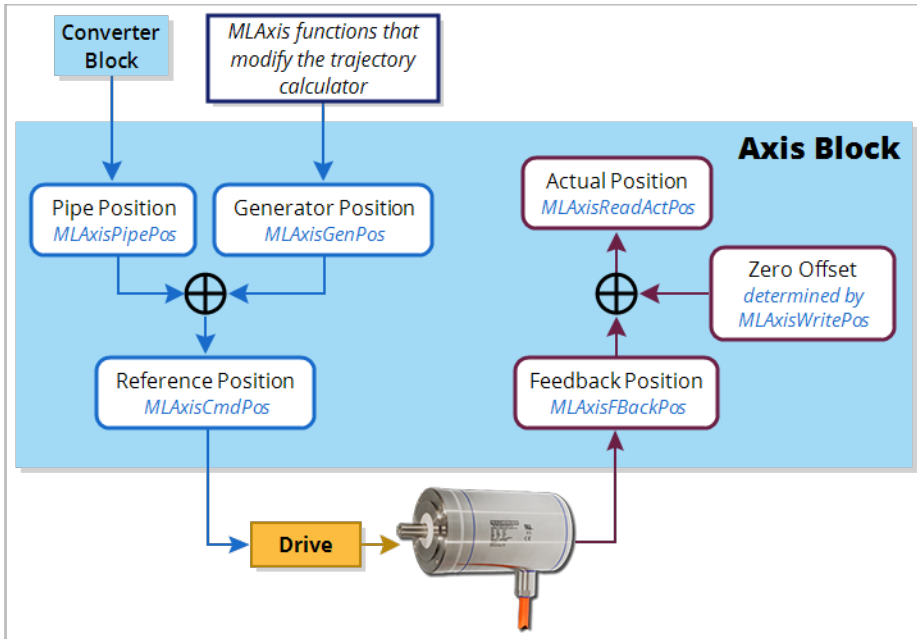

Figure 14-10: Axis Pipe Block Positions

12.7.10.2.7.1 Associated Data on Positions

This data are illustrated here:



NOTE

All positions are in user units with modulo applied if active, unless specified.

Position / Offset	Description
Actual Position	<p>This is the actual position of the underlying axis as reported by the drive.</p> <ul style="list-style-type: none"> It is the sum of the feedback value (Position actual value) returned from the communication link to the drive and any zero-offset due to an MLWritePos function block. See either MLAxisWritePipPos or MLAxisWritePos. <pre>ActualPos := FeedbackPos + ZeroOffset</pre>
Feedback Position	<p>This is the current position the drive reports for an axis, scaled to user units. It does not take into account the value of the Zero Offset or axis modulo.</p>
Generator Position	<p>This is the summation of all previous commands (i.e., calls to functions which perform motion) to the Axis internal motion generator. See either such as MLAxisAbs, MLAxisMoveVel, or MLAxisRel.</p> <ul style="list-style-type: none"> It is modified by MLAxisWritePos to insure no jumps in the Reference Position command. It accumulates changes in pipe position due to activate and deactivation of the pipe the Axis block is associated with.
Pipe Position	<p>This is the output of the convertor block is written into the Pipe Position value whenever the Converter block is connected to the axis and the pipe is active. See Motion / Pipe Network - Converter.</p>
Reference Position	<p>This is the commanded axis position sent to the drive. It is the summation of Pipe Position and Generator Position. $\text{ReferencePosition} = \text{Pipe Position} + \text{Generator Position}$</p>
Zero Offset	<p>This adjusts the coordinate system so the Actual Position reports correct values after homing or using MLAxisWritePos.</p>

12.7.10.2.8.2 Axis Block Initialization

A call to the `MLAxisInit` function block is required to implement motion for the axis.

- All positions and offsets are set to zero.
- The Axis Block motion generator is initialized with the proper ranges.
- Values are aligned: $\text{ReferencePosition} = \text{Pipe Position} + \text{Generator Position}$.

12.7.10.2.9.3 Axis Connection to a Pipe

A call to the `MLCNVConnect` function block is required to get motion generated in the pipe to the Axis.

- Pipe Offset calculation is: $\text{Pipe Offset} = \text{Pipe Position} - \text{Reference Position}$.
- Values are aligned: $\text{ReferencePosition} = \text{Pipe Position} + \text{Generator Position}$.

12.7.10.2.10.4 Change Axis Position Functions

Function	Description
<code>MLAxisAbs</code>	Performs a move to an absolute position.
<code>MLAxisAdd</code>	A selected Axis performs a move for a specified distance relative to the endpoint of the previous move.
<code>MLAxisMoveVel</code>	Jog at the specified speed.
<code>MLAxisReAlign</code>	Realigns the actual position with the reference position by moving the axis by the specified delta position.
<code>MLAxisRel</code>	A selected Axis performs a move for a specified distance relative to the current position.
<code>MLAxisStop</code>	Stop with the specified deceleration. This does NOT remove the input source, but to stop the drive from continuing to move.
<code>MLAxisWritePipPos</code>	Forces the pipe position internal value. ⚠ IMPORTANT This function works only when no pipe is connected.
<code>MLAxisWritePos</code>	Sets a new value to an axis' current location.
<code>MLCNVConnect</code>	Connects a converter Pipe Block to the specified axis.
<code>MLCNVDisconnect</code>	Disconnect a converter Pipe Block from its associated axis.
Motion / Pipe Network - Pipe	Starts calculating Pipe data. If the convertor block is connected to the axis it will reconnect the convertor and start updating the pipe position.
Motion / Pipe Network - Pipe	Stops sending Pipe data to the Axis Block Pipe Position and disconnects the convertor output from the axis.

12.7.10.2.11.5 Homing

Homing is the process of moving the motor to a known physical reference point on the machine.

- Homing can be performed with the **MLFB_Home*** Kollmorgen or by adding custom application code that uses only the Motion / Pipe Network - Axis function blocks.
 - The Pipe Network is typically not used in homing.
- Custom homing is done with `MLAxisRel` and `MLAxisAbs` to make motion and `MLAxisWritePos` to set a position offset.

12.7.10.2.12.6 Monitor an Axis

These are the function blocks to monitor the performance and status of an axis.

Function	Description
MLAxisCmdPos	Returns the reference position of the axis.
MLAxisGenIsRdy	Verifies if an axis is ready.
MLAxisReadActPos	Returns the actual position of the axis.
MLAxisReadGenStatus	Returns the status of the internal generator of the axis.
MLAxisStatus	Returns the status of the axis.

12.7.10.2.13.7 Multi-Axis Operation

For multi-axis applications, automatic operation requires both:

- Motion synchronization between two or more axes.
- The Pipe Network is required to achieve the synchronization.

To start up the Pipe Network, these two function calls must be executed in an application program:

```
PipeNetwork(MLPN_ACTIVATE) ;
PipeNetwork(MLPN_CONNECT) ;
```

Multi-axis synchronized motion is accomplished using a motion block associated with one of these input Pipe Blocks:

- Master: MLMstRun, MLMstRel, and MLMstAbs
- PMP: MLPmpAbs, MLPmpRel
- Sampler: MLSmpConnect, MLSmpConECAT, MLSmpConPNAxis, MLSmpConPLCAxis

12.7.10.2.14.8 Realign Positions

A call to the MLAxisReAlign function block is used to realign the axis after an error occurs

- Motion must come to a stop first.
- The MLAxisReAlign is executed.
You must set the movement of this block to MLAxisReadActPos - MLAxisCmdPos.
- The target position must be reached before any additional motion can occur.
It can be checked by using the MLAxisReAlgnRdy function block.

12.7.10.2.15.9 Set Zero Axis

A call to the MLAxisWritePos function block is used to set a position offset at the Axis when the Pipe Network is not yet connected.

- Pipe Position and Pipe Offset are set to zero.
- Generator Position is set to equal to Zero Position.
Zero Position is defined in MLAxisWritePos function block.
- Then $ReferencePosition = Pipe\ Position + Generator\ Position$.

12.7.10.2.16.10 Single-Axis Operation

This includes motion done on an individual axis block: jogging, absolute move, or incremental moves.

- If these are single-axis based, then motion is executed with the MLAxisMoveVel, MLAxisAbs, and MLAxisRel FBs.
 - These motions are typically done during machine setup or adjustment and are often referred to as manual mode.
 - For these operations, the Pipe Network does not need to be connected to the axis.

12.7.10.2.17.11 Units

User Units (abbreviated UU) are dimensions used in the application code to define axis position or distance for an axis.

The **User Units per Revolution** field is used to set how many of these custom units are associated with one revolution of the motor.

Examples

User Units	User Units per Revolution Value	Notes
Degrees	360.0	
Gradians	400.0	
Inches	15.7079632679489662	This equals pi*5. This could represent the circumference of a 5 inch diameter drum.
Radians	3.14159265358979324	

KAS standard units for velocity and acceleration are UU/sec and UU/sec².

12.7.10.2.18.12 View Axis Block Position Functions

Function	Description
MLAxisCmdPos	Returns the reference position of the axis.
MLAxisFBackPos	Returns the feedback position of the axis.
MLAxisGenPos	Returns the generator position of the axis.
MLAxisPipePos	Returns the pipe position of the axis.
MLAxisReadActPos	Returns the actual position of the axis.

12.7.10.2.19 Executing Motion

Axis block and Input block are the types of Pipe Blocks are used to command motion in a Pipe Network.

- **Axis block** starts motion directly on one axis.
- **Input blocks** start motion that affect all axes connected downstream in a Pipe Network.
 - Input blocks can be one of three types:
 - [Master](#) - Trapezoidal motion
 - [PMP](#) - Parabolic Motion
 - [Sampler](#) - Externally generated motion from another axis or external encoder.
- In this example:
 - Executing [MLAxisMoveVel](#), [MLAxisAbs](#) and [MLAxisRel](#) Functions can be used to cause motion on a particular axis.

- MLMstRun, MLMstAbs and MLMstRel functions cause motion on Axis1, Axis2 and Axis3.

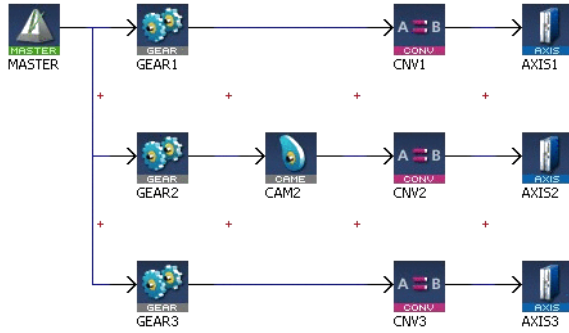

See these topics for more information:

- [click here...](#)
- ([→ # 576, Restarting Motion with Pipe Network](#))

12.7.10.2.20 Pipe Block Lifetime

Activation

- The pipe is activated when the output of the Convertor Pipe Block is connected to its related Axis.
- All characteristics are reset to the declaration values and the history of the block begins.

Usage

- As long as the pipe remains active, its values are cyclically calculated.
- Functions can be performed and events can be created.

Deactivation

- The pipe is deactivated when the deactivate function is applied to the pipe.
- All internal current values are lost and the block no longer exists.

12.7.10.2.21 Motion State Machine

The Motion State Machine is driven by the IEC 61131-3 application with the help of dedicated function blocks.

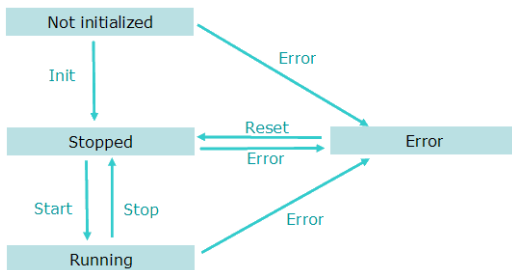

Figure 14-11: Motion State Machine

Each arrow represents a transition from one state to another.

12.7.10.2.22 Phase Execution in the Pipe Network

12.7.10.2.23.1 Absolute Phase of Execution

The absolute phase of execution of a pipe is the elapsed time between any fixed reference and the next computation for the specified pipe.

12.7.10.2.24.2 Relative Phase of Execution

The relative phase of execution between two pipes is the elapsed time between the computation of the first pipe and the second one.

- The relative phase of execution between two pipes of the same Pipe Network is 0 (zero).
- The phase of execution between two Pipe Networks cannot be specified by the user and depend on the pipe activation time of the application execution.

12.7.10.2.25 Use Motion Function Block for Pipe Network

Use motion library function blocks in your PLC application program to interface to the Pipe Network (see [click here...](#)).

ML function blocks are used to:

1. Create and initialize the Pipe Network.
2. Perform motion at a single-axis or multi-axis level.
3. Read information from points in the Pipe Network.

Example:

- Read a high-speed input position from a Trigger Pipe Block.
 - Read Command or Reference position from an Axis Pipe Block.
 - Determine when a position has been reached in a Comparator Pipe Block.
4. Modify how the blocks work in the Pipe Network.

Example:

- Change the phase offset of Phaser Pipe Block.
- Change the amplitude or offset of a CAM profile.
- Change the speed of a Master Pipe Block.

12.7.10.2.26.1 Buffer Mode

With the Pipe Network engine, when a motion function block is executed while another one is presently executing, there is an immediate change. That means the previous function block is aborted and the new one immediately becomes the active move and begins executing.

12.7.10.2.27.2 Motion Init

During initialization, the IEC 61131-3 application can create (using the `MLMotionInit` function) the different motion objects it needs (pipes, blocks, axes):

- Pipe Create
- Profile Create

NOTE

When the state machine leaves the Init state, the creation of new motion objects is no longer allowed. This is to avoid memory allocation problems while running the application.

12.7.10.2.28.3 Motion Start

The Start method (`MLMotionStart` function) initializes the motion engine, motion bus driver, and initializes the EtherCAT network to operational mode. `MLMotionStopbus` driver deactivates the execution of the motion engine.

The function blocks `MLMotionStart`, `MLMotionStop`, and `MLMotionRstErr` can be used by the IEC 61131-3 applications to navigate between states (i.e., Not initialized, Running, Stopped and Error).

12.7.10.2.29.4 Using the Q Output of ML Function Blocks for the Pipe Network

There is a Q output on most ML function blocks. The operation of the Q output is different for different ML function blocks. The Q output can be useful in PLC application programs.

Examples:

- MLAxisRel.Q is set when function block successfully executes.
- MLAxisStop.Q is set when motion is stopped (zero speed).
- MLPrfWriteOffset.Q is set if cam offset has been changed to the new value.

For more details on Q output, see (→ # 740, What is the Difference between Q and OK?)

12.7.10.2.30 Pipe Network - General Rules

This section outlines rules for using ML function in the Pipe Network context.

12.7.10.2.31.1 Languages

Functions that interact with the Pipe Network start with ML (e.g., MLAxisRel, MLPrfWriteOScale, or MLMstRel). These functions can be used in all the Programming Languages.

12.7.10.2.32.2 BlockID Inputs

The BlockID input is a DINT ID.

It is the second input to a Pipe Network function when using the FFLD Language:

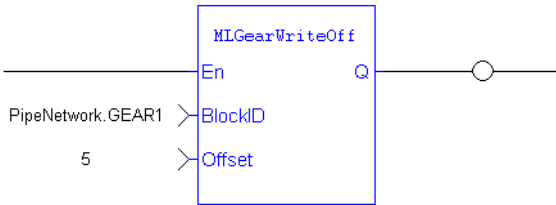

The BlockID input is the first one if programming in the ST Language:

```
MLGearRatSlp( BlockID (*DINT*));
```

This input identifies the block in the Pipe Network the function interacts with.

If using the graphical "Pipe Network Editor" (→ p. 480), the used variable starts with **PipeNetwork.xxx**.

The exception is if it is acting on a CAM profile, then the input is named ProfileID and the variable starts with **Profiles.xxx**.

TIP

When selecting a Pipe Block as the BlockID for an ML function, choose a Pipe Block with the same type which is in the name of the ML function.

Example: MLMstxxx functions expect a Master block to be chosen for the BlockID.

MLAxisxxx functions need an Axis block to be chosen for the AxisID input and MLPrfxxx functions need a Profile entered for ProfileID, etc.

12.7.10.2.33.3 Output Status

Most Pipe Network functions have a default Boolean output labeled either **Q** or **OK**:



12.7.10.2.34.4 What is the Difference between Q and OK?

- **OK** returns True when the function successfully executes.
- **Q** output is initially set to 0 (zero) until the first time the block is successfully executed in a running program.
 - After this execution, the Q output is set to 1.
 - It remains to 1 until the function does NOT execute successfully.
 - Alternately, after an unsuccessful execution the Q output is set to 0 (zero).
 - It remains to 0 (zero) until a successful execution resumes.

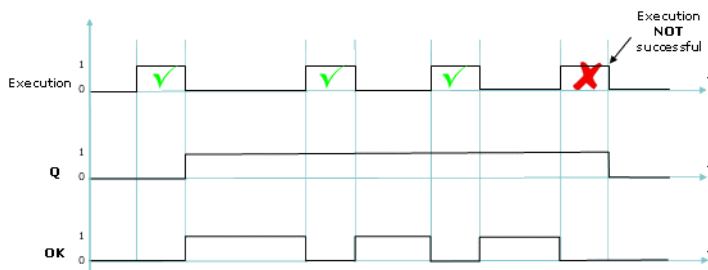

Figure 14-12: Execution Not Successful

12.7.10.2.35.5 When Q is Set to TRUE

Verify the description for each individual function block to be sure how its Q output is behaving.

- Some functions change the Q output from low to high immediately after it starts executing.
- Others (including most functions that command motion) wait to change the output until the function has completely finished executing.

12.7.10.2.36.6 Input Parameters

- The En input parameter, which is used to execute the function, is not edge-triggered.
 - If a function is seen in the PLC code and its En input is positive, the function executes.
- Example: A MLAxisRel command continuously executes relative moves in a program if it is called each program cycle; thus it acts as a Run/Jog command if continually commanded.

12.7.10.2.37.7 Missing Input Parameters

All inputs to a function must be entered for code to compile.

12.7.10.2.38.8 Position versus Distance

- **Position** is a value defined in a coordinate system.
- **DeltaPosition** is a relative measure related to technical units.
 - It is the difference between two positions.

12.7.10.2.39.9 Default Block Parameters

The parameters set when initializing a Pipe Network block are used as defaults when calling functions.

- These parameters can be modified in a program by using specific functions to set these values.
 - If a value is never set in a program the parameter entered during initialization is used.
- Example: When making a Master relative move (MLMstRel) you input the DeltaPosition but not the velocity or acceleration.

You can set the velocity for the move by using the MLMstWriteSpeed function before calling the relative move.

If the speed is not set in the program, the default parameter entered during the initialization (i.e., in the properties dialog box of the Pipe Blocks) is used.

12.7.10.2.40 Using the Generated Pipe Network Function

When the "Pipe Network Editor" (→ p. 480) is used, the KAS-IDE automatically creates a subprogram named **PNCode** and an instance of that subprogram named **Pipe Network**, which can be found in the Dictionary under **Global variables**.

The Pipe Network instance contains the IDs for all the pipe blocks created in the Pipe Network Editor. It also can execute certain actions when called as a function. These functions are:

- Pipe Network(MLPN_CREATE_OBJECTS) — Creates all Pipe Network related objects. This needs to be called first, before any other access to the Pipe Network instance. The Pipe Network template applications make this call in the **Main** program.
- Pipe Network(MLPN_ACTIVATE) — Activates all pipes defined in the Pipe Network Editor by calling Motion / Pipe Network - Pipe on each pipe.
- Pipe Network(MLPN_DEACTIVATE) — Deactivates all pipes defined in the Pipe Network Editor by calling Motion / Pipe Network - Pipe on each pipe.
- Pipe Network(MLPN_CONNECT) — Connects all converter blocks defined in the Pipe Network Editor to their associated axis blocks by calling MLCNVConnect on each converter block. This is typically done after all homing is completed.
- Pipe Network(MLPN_DISCONNECT) — Disconnects all converter blocks defined in the Pipe Network Editor from their associated axis blocks by calling MLCNVDisconnect on each converter block. This is typically done when axes need to be re-homed.
- Pipe Network(MLPN_POWER_ON) — Powers up (Enables) all axes defined in the Pipe Network Editor, enabling any associated servo or stepper drives mapped to the axes. This is done by calling MAxisPower on each axis block.
- Pipe Network(MLPN_POWER_OFF) — Powers down (Disables) all axes defined in the Pipe Network Editor, disabling any associated servo or stepper drives mapped to the axes. This is done by calling MAxisPower on each axis block.

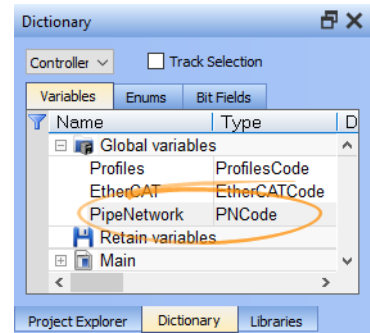

The IDs for the blocks used in the Pipe Network Editor are needed when writing code that accesses those function blocks. For example, when you need to read the actual position for an axis, you will need to use the pipe block ID in MAxisReadActPos:

```
// Structured Text Example
// Syntax = Function Name (PN Instance Name. Pipe Block ID)
MAxisReadActPos (PipeNetwork.AXIS1);
```

The IDs for the pipe blocks can be found in the dictionary under the **PNCode** subprogram but are accessed through the Pipe Network instance.

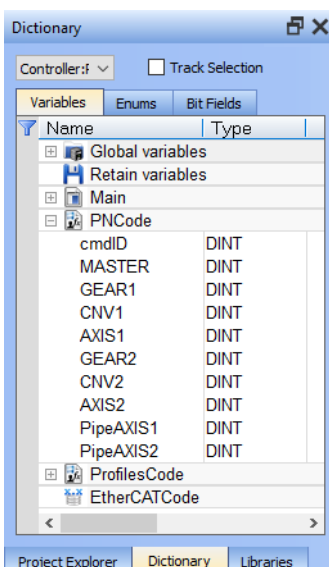

12.7.10.3 PLCopen®

Kollmorgen Automation Suite supports the International [PLCopen®](#) motion standard.

- The PLCopen international standard was created to obtain uniformity of motion function blocks and motion startup between machine control products.
- Users familiar with PLCopen are automatically familiar with PLCopen inside the KAS-IDE.
- The PLCopen function blocks for Motion Control, is based on the IEC 61131-3 "Function Blocks" (→ p. 715) concept with these factors in consideration:
 - Completeness
 - Consistency - conforming to the IEC 61131-3 standard
 - Efficiency - in the number of function blocks, for efficiency in design (and understanding)
 - Flexibility - future extensions / range of applications
 - Simplicity - ease of use for the application program builder and installation & maintenance
 - Universality - hardware independent

KAS supports PLCopen motion in these program formats: FBD, FFLD, IL, SFC, and ST.

- PLCopen blocks in KAS start with MC (e.g., MC_MoveAbsolute).
 - MC blocks are an alternative to using the ML Motion function blocks (e.g., MLAxisAbs) and associated Pipe Networks in many applications.
- Using MC Motion function blocks does **not** require a separate motion editor.

12.7.10.3.1 PLCopen Function Blocks

This function block (FB) library is designed for controlling one or more servo axes using the IEC 61131-3 [PLCopen](#) standard. See "Function Blocks" (→ p. 715).

To offer flexibility, ease of use, and reusability, the library consists of command-oriented function blocks with a reference to the axis (e.g., the abstract data type "AXIS_REF Structure" (→ p. 768)).

The PLCopen Library contains function blocks for:

- **Control:** Function blocks to define and initialize motion, control power, and reset errors.
- **I/O:** Function blocks to control interaction with Digital I/O and Touch Probe and trigger "PLCopen Registration" (→ p. 566) functionality.
- **Info:** Function blocks to provide information on motion, position, status, and the ability to read and write other drive parameters.
- **PLCopen Motion:** Function blocks to execute different types of motion.
- **Profile:** Function blocks for master/slave motion.
- **Reference:** Function blocks to reset position.
- **Registration:** Function blocks to perform registration.

Function Block	Description
MC_AddSuperAxis	Adds a Superimposed Axis to the Axis's list of assigned superimposed axes.
MC_CamIn	Performs a slave axis move which follows the master axis based on the Cam Table specified by CamTableID.
MC_CamOut	Disengages the slave axis from an MC_CamIn move or the master axis immediately in a cam block.
MC_CamTblSelect	Defined to read and initialize the specified profile. Selects the Cam tables by setting the pointers to the relevant tables.
MC_GearIn	Performs a slave axis move which follows the master axis based on the ratio specified by RatioNumerator and RatioDenominator.
MC_GearOut	Disengages the slave axis from a MC_GearIn or MC_GearInPos move or the master axis.
MC_MachRegist	Enables Mark-to-Machine registration.

Function Block	Description
MC_MarkRegist	Enables Mark-to-Mark registration.
MC_MoveAbsolute	Performs a single-axis move to a specified endpoint position.
MC_MoveAdditive	Performs a single-axis move for a specified distance from the endpoint of the previous move.
MC_MoveRelative	Performs a single-axis move of a specified distance relative to the actual position at the time of the start of execution.
MC_MoveSuperimp	Performs a single-axis move superimposed upon the currently executing move.
MC_MoveVelocity	Performs a single-axis, non-ending move at a specified velocity.
MC_Power	Requests to either enable the drive and close the loop, or disable the drive and open the loop.
MC_ReadActPos	Reads the actual position of the axis.
MC_ReadAxisErr	Returns the error status of the specified axis.
MC_ReadBoolPar	Returns the value of the specified Boolean axis parameter. Returns the value of a drive parameter. <ul style="list-style-type: none"> The returned value has to be converted to REAL if required. If not possible, the vendor must provide a supplier-dependent FB for it.
MC_ReadParam	Returns the value of the specified axis parameter. Returns the value of a drive parameter. <ul style="list-style-type: none"> The returned value has to be converted to REAL if required. If not possible, the vendor must provide a supplier-dependent FB for it.
MC_ReadStatus	Returns the state of the specified axis.
MC_RemSuperAxis	Remove an axis from the axis's list of assigned, superimposed axes.
MC_ResetError	Resets the errors of the specified axis.
MC_Stop	Aborts the active move, removes the next move from the queue, performs a controlled stop, and switches the axis to Stopping state.
MC_StopRegist	Turns off registration for the specified axis and disarms the specified fast input.
MC_WriteBoolPar	Writes the specified axis Boolean parameter.
MC_WriteParam	Writes the specified axis parameter.

12.7.10.3.2.1 PLCopen Function Block ErrorIDs

These are the errors returned in the ErrorID output of the function blocks.

ErrorID	Description
0	No error.
1	Queue full.

ErrorID	Description
2	Abort mode required.
3	Invalid axis.
4	One of these possible scenarios: <ul style="list-style-type: none"> • Invalid master axis. • Master axis and slave axis are the same. • Master axis is currently slaved to the specified slave axis. • Master axis and slave axis do not have the same update rate.
5	Invalid parameter number.
6	Invalid move.
7	Invalid override.
8	Buffer mode required.
9	Invalid parameter data.
10	Move cannot be executed because either: <ul style="list-style-type: none"> • An axis error exists. • The axis is in the stopping state. • The axis is disabled.
11	Invalid buffer mode.
12	Move was aborted due to an E-stop.
13	Move was aborted due to a controlled stop.
14	Invalid start mode or sync mode.
15	Invalid cam profile.
16	Invalid slave count.
17	Input value is out of range.
18	Cannot access time stamp or latched position data.
19	Data not available. Example: If a MC_ReadParam of FollowingError (1006) is programmed on a simulator axis where no following error is available, an error 19 (data not available) is returned.
20	Motion engine is not running.
21	Invalid ratio of velocity to acceleration, or acceleration to jerk. See "Limitations on Acceleration and Jerk" (→ p. 775).
22	Too many profiles – the number of selected profiles is limited to 256.
23	Internal Error.
24	Object already exists.
25	Block needs to be called between MLMotionInit and MLMotionStart.
26	The axis is owned by another group.
27	The axis is already present in the group.
28	No axes are mapped to the group.

ErrorID	Description
29	Invalid name. A name cannot be an empty string.
30	Name is already used.
31	The number of axes is too small.
32	The number of axes is too large.
33	Invalid update rate.
34	Invalid axis group.
35	Invalid kinematic parameter (i.e., position, speed, velocity, acceleration, deceleration, or jerk).
36	Invalid floating point number.
37	Invalid object index.
38	Invalid number of positions in array.
39	Position is not a valid number.
40	Invalid coordinate system.
41	Axis is not initialized.
42	Array is not the correct size.
43	A move cannot be made while the group is in a stopping state.
44	The axes group is not in the Disabled or Standby state.
45	The axes group is in the Disabled state.
46	The axis is not in this axes group.
47	Duplicate points specified.
48	Invalid radius specified.
49	Co-linear points were specified for the border points of a circle.
50	Cannot construct a circle with specified parameters.
51	Invalid circle mode.
52	Invalid path choice for circular move.
53	Invalid transition mode.
54	The axis group does not have exactly two axes. Example: Transitions are only allowed on groups with two axes.
55	Invalid engine type for axis.
56	An axis or its associated drive is in an error state.
57	Cannot execute function because both queues are not empty.
58	Lines are parallel.
59	Not enough room for transitions.
60	Abort mode not allowed for Circular Absolute moves.
61	Invalid transition parameters.
62	Transition not allowed with Abort Move.

ErrorID	Description
63	The axes group is not in the Standby state.
64	The maximum number of axes has been created.
65	The axis is not powered on.
66	Error in data reported from drive.
67	The axes group is not in the ErrorStop state.
68	The axes group is still in Error State.
69	The axes group is not in Standby or ErrorStop state.
70	The fast input is in use.
71	Set position is in progress.
72	Invalid data point count.
73	Position Axis and Trigger Axis cannot be different for position mode trigger.
74	Invalid Fast Input trigger mode.
75	Cannot simultaneously perform motion from different motion engines.
76	Cannot call this function block twice in the same cycle with the same value for execute input. This error may arise from these scenarios: <ul style="list-style-type: none"> The user application code was written to call the function block more than once in the same cycle. The PLC program is overloaded causing the application to think the function block is called more than once in the same cycle.
77	An axis is in a controlled stop error state.
78	Invalid kinematic transform type specified.
79	Invalid kinematic transform parameter specified.
80	Axes group has no ACS to MCS transform specified.
81	The maximum number of transforms has been created.
82	Invalid transition between coordinate systems.
83	Invalid enabled physical axes count.
84	Operation is not valid when the axis is enabled.
86	The requested transition mode is not supported.
87	The remaining distance of the active move is shorter than the transition corner distance.
88	Aborting a move during an S-Curve Corner transition is not allowed.
100	The Cam_Data array is not large enough to hold the specified number of elements.
101	Invalid master or slave scale. The scale cannot be less than 0 (zero).
102	Element master or slave position is outside the range defined by Cam_Props.
103	A segment type was specified that is not supported by the value of the Options argument.
104	Master position of an element is too close to the master position of a previous element.
106	Invalid profile ID.

ErrorID	Description
107	CamDataCount argument exceeds maximum array size of 20,000 data points.
108	Profile is currently is use.
109	Attempting to build a profile already containing elements.
110	Unable to allocate cam table.
111	Too few cam elements specified.
112	Cam elements are not sorted.
113	Average segment velocity outside of range defined by start and end element velocities.
200	First element's MasterIn value not equal to 0 (zero).
201	Last element's MasterIn value does not equal value of InputScale.
202	Cannot modify the first element in the cam element table. SlaveOut value is outside the output range specified by Cam_Props.
203	Cannot modify the last element in the cam element table. SlaveOut value is outside the output range specified by Cam_Props.
204	Unknown cam error.

12.7.10.3.3.2 Axes Group Parameters

12.8 Boolean Parameters

This is a list of Boolean parameters currently supported.

These parameters are read and written by the MC_GrpReadBoolPar and MC_GrpWriteBoolPar function blocks.

Parameter	ID	Name	R/W	Description
MC_GRP_PARAM_IGNORE_AXIS_ESTOP	1000	Ignore Axis EStop	Read/Write	<ul style="list-style-type: none"> Controls whether the axes group continues performing motion if one of the member axes is experiencing an Estop. FALSE indicates the axes group should enter an Estop state if a member axis enters the Estop state. TRUE indicates the axes group should continue performing motion.
MC_GRP_PARAM_AXIS_ESTOP_ACTIVE	1001	Axis EStop Active	Read Only	<ul style="list-style-type: none"> This Read-only parameter is TRUE whenever an axis in the group is experiencing an axis Estop Error. When there are no axis Estop Errors present on the axes in a group, this parameter is FALSE.

12.9 Non-Boolean Parameters

This is a list of non-Boolean parameters currently supported.

These parameters are read and written by the MC_GrpReadParam and MC_GrpWriteParam function blocks.

Parameter	ID	Name	R/W	Description
MC_GRP_ PARAM_CIRCLE_ TOLERANCE	2000	Command Velocity	Read/Write	<ul style="list-style-type: none"> This parameter controls how large an error is acceptable when constructing circles using circle mode MC_CIRC_MODE_CENTER. Zero defaults to the 1 part in 100,000 tolerance. See "Precision Requirements for Circular Move Input Parameters" (→ p. 524) for more information.

12.9.0.0.1.1 Axis Parameters

See:

- "Boolean Parameters" (→ p. 751)
- "Non-Boolean Parameters" (→ p. 756)

12.10 Update Rate Types

12.10.1 Controller

The update rate depends on KAS application program update rate.
See "Define the PLC Cycle" (→ p. 219).

12.10.2 EtherCAT Cyclic

The update rate depends on the EtherCAT.
See these topics about update rates:

- "EtherCAT Master Settings tab" (→ p. 327)
- "Define the PLC Cycle" (→ p. 219)

12.10.3 EtherCAT Non-Cyclic

The update rate depends on the reading of the parameter through EtherCAT.

12.10.4 Static

The Values do not change after the axis is created.

12.11 User Units to Feedback Units Ratio

Parameters "Non-Boolean Parameters" (→ p. 756) and "Non-Boolean Parameters" (→ p. 756) are set during the MC_CreatePLCAxis function block execution.

- These two parameters work together to form the User Units to Feedback Units Ratio (UU/FBU Ratio).
- The drive interface units are fixed by the drive and define the drive units per revolution.
 - This is used to command the drive per the ratio.

12.11.1 Example 1

Where the drive interface units are set to 1048576 units per revolution, the value of the **UU-per-revolution** ratio is calculated as:

$$\text{UU per revolution} = \text{MC_AXIS_PARAM_UU_FB_RATIO_NUM} * 1048576 / \text{MC_AXIS_PARAM_UU_FB_RATIO_DEN}$$

12.11.2 Example 2

A Drive with a Ratio of:	Generates Revolution of Drive Motor	Generates UU-to-FBU Ration
360 UU / 1048576 FBU	360 UU	0.000343323
11379 UU / 189899640 FBU	6.283185 UU	5.99211e-6

12.11.3 Example 3 - Reading the Current to Units of Amps

After reading the current using MC_ReadParam, this equation converts current to amps for a 12 amp peak drive:

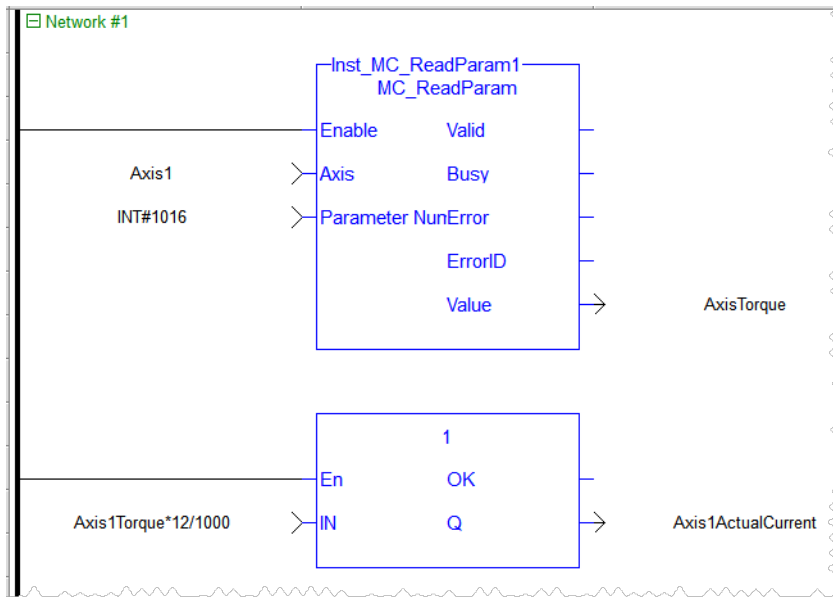
$$\text{MC_AXIS_PARAM_TORQUE_ACTUAL} * \text{Drive Continuous Current Rating} / 1000$$

13 Boolean Parameters

This table is a list of Boolean supported parameters.

These parameters are read and written by the function blocks MC_ReadBoolPar and MC_WriteBoolPar.

"1011" (→ p. 751) "1013" (→ p. 751) "1025" (→ p. 751) "1026" (→ p. 751)
 "1027" (→ p. 752) "1033" (→ p. 753) "1038" (→ p. 755)

13.0.1 Parameter Details

ID	Parameter	Name	R/W	Update Rate Type	Description
1011	MC_AXIS_PARAM_IN_POSITION	Axis In-Position	Read-only	"Controller" (→ p. 749)	<ul style="list-style-type: none"> • TRUE if the axis: <ul style="list-style-type: none"> • Has no active or next move queued. • Command delta is 0 (zero). • Actual position is within the in-position bandwidth of the command position. • FALSE otherwise, Boolean.
1013	MC_AXIS_PARAM_DRIVE_WARNING	Drive Warning	Read-only	"EtherCAT Cyclic" (→ p. 749)	Drive Warning Status. See Note 1 .
1025	MC_AXIS_PARAM_REGIST_GOOD	Good Registration Mark Occurred	Read-only	"EtherCAT Non-Cyclic" (→ p. 749)	<ul style="list-style-type: none"> • TRUE indicates a good registration mark was encountered. • This Boolean is automatically reset after it has been read. <ul style="list-style-type: none"> • See Note 2.
1026	MC_AXIS_PARAM_REGIST_BAD	Bad Registration Mark Occurred	Read-only	"EtherCAT Non-Cyclic" (→ p. 749)	<ul style="list-style-type: none"> • TRUE indicates a bad registration mark was encountered. • This Boolean is automatically reset after it has been read. <ul style="list-style-type: none"> • See Note 2.

ID	Parameter	Name	R/W	Update Rate Type	Description
1027	MC_AXIS_PARAM_FL_OCCURRED	Fast Input Occurred	Read-only	"EtherCAT Non-Cyclic" (→ p. 749)	<ul style="list-style-type: none"> This parameter is deprecated. The recommended replacement is the Done output of the MC_TouchProbe function block to verify if the fast input has occurred. <p>Deprecated Behavior</p> <ul style="list-style-type: none"> TRUE if a fast input occurred on either Capture Engine 0 or Engine 1. This Boolean is automatically reset after it has been read. <ul style="list-style-type: none"> See Note 3.

ID	Parameter	Name	R/W	Update Rate Type	Description
1033	MC_AXIS_ PARAM_APPLY_ SUPERIMPOSED_ DISTANCE	Apply Superimposed Distance	Read / Write	"Controller" (→ p. 749)	<p>The default value for this parameter is FALSE.</p> <ul style="list-style-type: none"> If FALSE, MC_MoveAbsolute does not take into account any added superimposed distance due to MC_MoveSuperimp. The final reported position of the axis, which does include superimposed distance, may not be equal to the Position input to MC_MoveAbsolute. <p>Click for an Example of FALSE</p> <pre> Param 1033 = False MC_ MoveSuperimp move 1 +50 MC_ MoveSuperimp move 2 - 35 MC_ MoveAbsolute 125 (superimposed distance = 50-35 = 15) End Position = 140 </pre> <ul style="list-style-type: none"> If TRUE, MC_MoveAbsolute compensates for all added

ID	Parameter	Name	R/W	Update Rate Type	Description
					<p>superimposed distance from MC_ MoveSuperimp calls at the time of the initial MC_ MoveAbsolute call.</p> <ul style="list-style-type: none"> • The final reported position of the axis is equal to the Position input to MC_ MoveAbsolute. • If MC_ MoveSuperimp is called during MC_ MoveAbsolute, then the final position includes the superimposed distance. <p>Click for an Example of TRUE</p> <pre data-bbox="1209 1115 1433 1720"> Param 1033 = True MC_ MoveSuperimp move 1 +50 MC_ MoveSuperimp move 2 - 35 MC_ MoveAbsolute 125 End Position = 125 </pre>

ID	Parameter	Name	R/W	Update Rate Type	Description
1038	MC_AXIS_ PARAM_IGNORE_ DRIVE_LIM_ STATUS	Ignore Drive Limit Active	Read / Write	"EtherCAT Non- Cyclic" (→ p. 749)	<ul style="list-style-type: none"> When TRUE, the Pipe Network motion engine ignores the DS-402 Status word bit 11 (Internal Limit Active). See "Overtravel Conditions" (→ p. 553).

Notes

See "Tuning Controller Performance for EtherCAT Communication Latency" (→ p. 578).

1. This is a configuration parameter.
2. There is some delay in acquiring fast input information from drives and calculating the registration marks. While the information is evaluated cyclically, there may be a few cycles between when the fast input occurs and the system records the registration marks.
3. There is some delay in acquiring fast input information from drives and calculating the fast input position. While the information is evaluated cyclically, there may be a few cycles between when the fast input occurs and the system records the fast input data.
4. There is some delay in acquiring the actual position values. While the information is evaluated cyclically, there may be a few cycles between when the actual position is updated in the drive and the system records the fast input data.

See Also

- "Axis Parameters" (→ p. 749)
- "Non-Boolean Parameters" (→ p. 756).

14 Non-Boolean Parameters

This table is a list of non-Boolean parameters currently supported.

These parameters are read and written by the function blocks MC_ReadParam and MC_WriteParam.

"1" (→ p. 756)	"10" (→ p. 756)	"11" (→ p. 756)	"1000" (→ p. 756)	"1001" (→ p. 757)	"1002" (→ p. 757)	"1003" (→ p. 757)	"1004" (→ p. 757)	"1005" (→ p. 757)
"1006" (→ p. 757)	"1007" (→ p. 758)	"1008" (→ p. 758)	"1009" (→ p. 759)	"1010" (→ p. 759)	"1012" (→ p. 759)	"1014" (→ p. 759)	"1015" (→ p. 760)	"1016" (→ p. 760)
"1017" (→ p. 760)	"1018" (→ p. 760)	"1019" (→ p. 761)	"1020" (→ p. 761)	"1021" (→ p. 761)	"1022" (→ p. 761)	"1023" (→ p. 762)	"1024" (→ p. 763)	"1028" (→ p. 763)
"1029" (→ p. 763)	"1030" (→ p. 763)	"1031" (→ p. 764)	"1032" (→ p. 764)	"1034" (→ p. 764)	"1035" (→ p. 764)	"1036" (→ p. 765)	"1037" (→ p. 766)	

14.0.1 Parameter Details

ID	Parameter	Name	R/W	Update Rate Type	Description
1	MC_AXIS_PARAM_CMD_POS	Command Position	Read-only	"Controller" (→ p. 749)	<ul style="list-style-type: none"> Axis command position – includes any command deltas from superimposed axes. User units. If a set position is in process due to homing or registration, there may be a 1 cycle delay.
10	MC_AXIS_PARAM_ACT_VEL	Actual Velocity	Read-only	"EtherCAT Cycle" (→ p. 749)	<ul style="list-style-type: none"> Axis actual velocity User unit/sec
11	MC_AXIS_PARAM_CMD_VEL	Command Velocity	Read-only	"Controller" (→ p. 749)	<ul style="list-style-type: none"> Axis command velocity – includes any command deltas from superimposed axes. User unit/sec
1000	MC_AXIS_PARAM_PHASE_SHIFT	Phase Shift	Read-only	"Controller" (→ p. 749)	<ul style="list-style-type: none"> The amount of phase shift applied by MC_Phasing. Slave axis' user units

ID	Parameter	Name	R/W	Update Rate Type	Description
100 1	MC_AXIS_ PARAM_ SUPERIMPOS ED_ DISTANCE	Superimposed Distance	Read- only	"Controller" (→ p. 749)	<ul style="list-style-type: none"> The cumulative distance traveled via MC_MoveSuperimp moves. User units
100 2	MC_AXIS_ PARAM_ MASTER_ OFFSET	Master Offset	Read / W rite	"Controller" (→ p. 749)	<ul style="list-style-type: none"> Write: The amount to increment the master offset for an active master/slave move. <ul style="list-style-type: none"> User units. Read: The amount of master offset applied. <ul style="list-style-type: none"> User units.
100 3	MC_AXIS_ PARAM_ SLAVE_ OFFSET	Slave Offset	Read / W rite	"Controller" (→ p. 749)	<ul style="list-style-type: none"> Write: The amount to increment the slave offset for an active master/slave move. <ul style="list-style-type: none"> User units. Read: The amount of slave offset applied. <ul style="list-style-type: none"> User units.
100 4	MC_AXIS_ PARAM_ MOVE_TYPE_ ACTIVE	Active Move Type	Read- only	"Controller" (→ p. 749)	The active move type. See Move Types.
100 5	MC_AXIS_ PARAM_ MOVE_TYPE_ NEXT	Next Move Type	Read- only	"Controller" (→ p. 749)	The queued (next) move type. See Move Types.
100 6	MC_AXIS_ PARAM_ POSITION_ ERROR	Position Error	Read- only	"EtherCAT Cy clic" (→ p. 749)	Position error in user units.

ID	Parameter	Name	R/W	Update Rate Type	Description
1007	MC_AXIS_PARAM_FEEDBACK_LAST	Raw Feedback	Read-only	"EtherCAT Cycle" (→ p. 749)	<ul style="list-style-type: none"> Raw Feedback position in user units. Keeps track of the actual position based on the physical feedback device connected to the drive. Not offset as a result of calling MC_SetPos.
1008	MC_AXIS_PARAM_ROLLOVER_POSITION	Rollover	Read / Write	"Controller" (→ p. 749)	<ul style="list-style-type: none"> The axis rollover position is in User units. If the axis is a servo axis: <ul style="list-style-type: none"> This parameter can only be written when there are no moves in the queue. ¹ When this parameter is changed, the new position is scaled from the old position. <p>In particular:</p> <div style="border: 1px solid black; padding: 5px; margin-top: 10px;"> $\text{New Position} = \text{OldPosition} * \frac{\text{New Rollover}}{\text{Old Rollover}}$ </div>

ID	Parameter	Name	R/W	Update Rate Type	Description
1009	MC_AXIS_PARAM_VELCOMP_FACTOR	Velocity Compensation Factor	Read / Write	"Controller" (→ p. 749)	<ul style="list-style-type: none"> The factor used to multiply the velocity compensation value to account for the number of updates of delay in transmission of the feedback value from the drive to the control. See "Velocity Compensation" (→ p. 776). <ul style="list-style-type: none"> See Note 1 and Note 4.
1010	MC_AXIS_PARAM_VELCOMP_FILTER	Velocity Compensation Filter	Read / Write	"Controller" (→ p. 749)	<ul style="list-style-type: none"> The number of updates to apply a change in velocity compensation. See "Velocity Compensation" (→ p. 776). <ul style="list-style-type: none"> See Note 1 and Note 4.
1012	MC_AXIS_PARAM_IN_POSITION_BAND	Axis In-Position Bandwidth	Read / Write	"Controller" (→ p. 749)	<p>The bandwidth about the command position to determine the state of the in-position flag.</p> <p>See Note 2.</p>
1014	MC_AXIS_PARAM_DRIVE_STATUS	Drive Status	Read-only	"EtherCAT Cycle" (→ p. 749)	<ul style="list-style-type: none"> Drive Status Word <ul style="list-style-type: none"> Similar to MAxisStatus. Some status bits are set only at program startup.

ID	Parameter	Name	R/W	Update Rate Type	Description
101 5	MC_AXIS_ PARAM_UU_ FB_RATIO_ NUM	User Unit to feedback unit ratio numerator	Read- only	"Static" (→ p. 749)	<ul style="list-style-type: none"> The numerator of the user-units-to-feedback-units ratio (UU/FBU Ratio). See "User Units to Feedback Units Ratio" (→ p. 749). <ul style="list-style-type: none"> See Note 1.
101 6	MC_AXIS_ PARAM_ TORQUE_ ACTUAL	Actual Torque	Read- only	"EtherCAT Cy- cler" (→ p. 749)	<ul style="list-style-type: none"> The actual torque being delivered by the drive, expressed in thousandths of max torque. See "Example 3 - Reading the Current to Units of Amps" (→ p. 750).
101 7	MC_AXIS_ PARAM_BUS_ ADDRESS	Drive Address	Read- only	"Static" (→ p. 749)	<ul style="list-style-type: none"> Drive address value used in EtherCAT fieldbus functions as drive address. Before using in fieldbus functions, this value needs to be converted to an integer by using a convert any to DINT function. <ul style="list-style-type: none"> See Note 1.
101 8	MC_AXIS_ PARAM_ SENSOR_ DELAY	Sensor Delay	Read / W rite	"Controller" (→ p. 749)	<p>Compensation for Physical sensor delay for MC_TouchProbe, in microseconds.</p> <p>See Note 1.</p>

ID	Parameter	Name	R/W	Update Rate Type	Description
1019	MC_AXIS_PARAM_INTERP_CMD_POS	Interpolated Command Position	Read-only	"Controller" (→ p. 749)	<ul style="list-style-type: none"> Command position solely from this axis's interpolator (in User units). This value does not include any command deltas from other axes that are currently superimposed upon it.
1020	MC_AXIS_PARAM_INTERP_CMD_VEL	Interpolated Command Velocity	Read-only	"Controller" (→ p. 749)	<ul style="list-style-type: none"> Command velocity solely from this axis's interpolator (in user units). This value does not include any command deltas from other axes that are currently superimposed upon it.
1021	MC_AXIS_PARAM_REGIST_COMP	Registration Compensation	Read-only	"Controller" (→ p. 749)	<ul style="list-style-type: none"> The latest calculated registration compensation value. This value is updated each time a good registration mark is encountered. This value is in User units.
1022	MC_AXIS_PARAM_REGIST_DIST	Distance Between the Last Two Good Registration Marks	Read-only	"EtherCAT Non-Cyclic" (→ p. 749)	<ul style="list-style-type: none"> The distance between the last two good registration marks. This value is in User units. <ul style="list-style-type: none"> See Note 2.

ID	Parameter	Name	R/W	Update Rate Type	Description
1023	MC_AXIS_PARAM_REGIST_GOOD_CNT	Number of Consecutive Good Registration Marks	Read / Write	"EtherCAT Non-Cyclic" (→ p. 749)	<ul style="list-style-type: none"> • Number of consecutive good registration marks. • This value is incremented each time a good registration mark is encountered. <ul style="list-style-type: none"> • It is automatically zeroed when a bad registration mark is encountered. • The ability to write this parameter is provided to allow the application to zero this value. <ul style="list-style-type: none"> • See Note 2.

ID	Parameter	Name	R/W	Update Rate Type	Description
1024	MC_AXIS_PARAM_REGIST_BAD_CNT	Number of Consecutive Bad Registration Marks	Read / Write	"EtherCAT Non-Cyclic" (→ p. 749)	<ul style="list-style-type: none"> Number of consecutive bad registration marks. This value is incremented each time a bad registration mark is encountered. <ul style="list-style-type: none"> It is automatically zeroed when a good registration mark is encountered. The ability to write this parameter is provided to allow the application to zero this value. <ul style="list-style-type: none"> See Note 2.
1028	MC_AXIS_PARAM_UU_FB_RATIO_DEN	User units to feedback unit ratio denominator	Read-only	"Static" (→ p. 749)	<ul style="list-style-type: none"> The denominator of the User units to feedback-units ratio (UU/FBU Ratio). See "User Units to Feedback Units Ratio" (→ p. 749).
1029	MC_AXIS_PARAM_CM_ACT_CMD_POS	Coordinated Motion Applied Command Position	Read-only	"Controller" (→ p. 749)	Amount of motion actually applied to the PLCopen axis drive by Coordinated Motion commands.
1030	MC_AXIS_PARAM_CM_CMD_POS	Coordinated Motion Command Position	Read-only	"Controller" (→ p. 749)	Amount of motion requested of a PLCopen axis by the Coordinated Motion commands.

ID	Parameter	Name	R/W	Update Rate Type	Description
103 1	MC_AXIS_ PARAM_ INGEAR_ BANDWIDTH	In Gear bandwidth	Read / Write	"Controller" (→ p. 749)	<ul style="list-style-type: none"> The bandwidth about the target slave velocity where the slave axis locks onto the master axis and the InGear output turns on for the MC_GearIn function block. User unit/sec Default value = 0.1. See Note 1.
103 2	MC_AXIS_ PARAM_ DRIVE_AXIS_ NUMBER	Drive Axis Number	Read-only	"Static" (→ p. 749)	One-based number that specifies the axis on the drive.
103 4	MC_AXIS_ PARAM_UU_ FB_RATIO	User units to feedback unit ratio	Read-only	"Controller" (→ p. 749)	<ul style="list-style-type: none"> The User units to feedback units ratio for the axis. See "User Units to Feedback Units Ratio" (→ p. 749).
103 5	MC_AXIS_ PARAM_BUS_ INTERFACE_ TYPE	Bus Interface Type	Read-only	"Static" (→ p. 749)	<p>The parameter value is:</p> <ul style="list-style-type: none"> DRIVE_BUS_INTERFACE_ECAT when the axis is associated with an EtherCAT device. DRIVE_BUS_INTERFACE_SIMULATOR when the axis is simulated.

ID	Parameter	Name	R/W	Update Rate Type	Description
103 6	MC_AXIS_ PARAM_SIM_ CLOSING	Simulator Distance Closing Fraction	Write- only	"Controller" (→ p. 749)	<p>This setting affects how responsive a simulated axis to changing command positions.</p> <ul style="list-style-type: none"> The valid range of this parameter is (0.0, 1.5]. The default value is 0.7. <p>Values are broken down into these ranges:</p> <ul style="list-style-type: none"> (0.0, 1.0): Simulate following error. <ul style="list-style-type: none"> A value of 0.1 generates a large following error. A value of 0.9 generates a small following error. 1.0: No following error. (1.0, 1.5]: Simulate leading error. <p>TIP A value of 1.0 is recommended when using an axis as a virtual master to command motion through camming and/or gearing.</p>

ID	Parameter	Name	R/W	Update Rate Type	Description
1037	MC_AXIS_PARAM_UU_REV_RATIO	User units revolution ratio	Read / Write	"Controller" (→ p. 749)	<ul style="list-style-type: none"> The user units per revolution ratio for the axis. See "Axis Data Parameters" (→ p. 172). <div style="border: 1px solid black; padding: 5px; margin-top: 10px;"> <p>⚠ WARNING</p> <p>Do NOT change the user units per revolution ratio when the axis is enabled, geared, or cammed to another axis. Undefined behavior may result.</p> </div>

Notes

See "Tuning Controller Performance for EtherCAT Communication Latency" (→ p. 578).

- This is a configuration parameter.
- There is some delay in acquiring fast input information from drives and calculating the registration marks. While the information is evaluated cyclically, there may be a few cycles between when the fast input occurs and the system records the registration marks.
- There is some delay in acquiring fast input information from drives and calculating the fast input position. While the information is evaluated cyclically, there may be a few cycles between when the fast input occurs and the system records the fast input data.
- There is some delay in acquiring the actual position values. While the information is evaluated cyclically, there may be a few cycles between when the actual position is updated in the drive and the system records the fast input data.

See Also

- "Axis Parameters" (→ p. 749)
- "Boolean Parameters" (→ p. 751).

14.0.1.0.1.1 Axis Positions Data

14.1 Actual Position

This is the position of the axis read from the drive interface, which is read from the feedback device.

14.2 CommandPosition

This is the command position (without modulo and in the axis' user units) sent to the drive interface to command an axis.

This position is tied to the Status output of the MC_Power function block:

- Status = 1: The command position is a combination of the Normal, Superimposed, and Phasing commands.
- Status = 0: The command position tracks the Actual Position.

14.2.1 CoordinatedMotionCmdPos

This is the command position generated by the Coordinated Motion Interpolator when interpolating coordinated motion moves.

14.2.2 Group Actual Position

This is the set of positions of an axes group read from the axis interface:

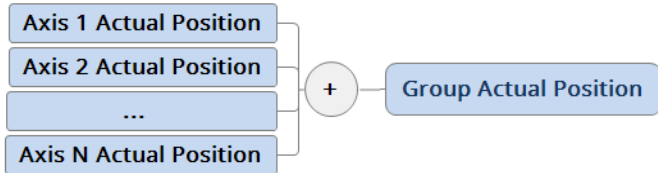
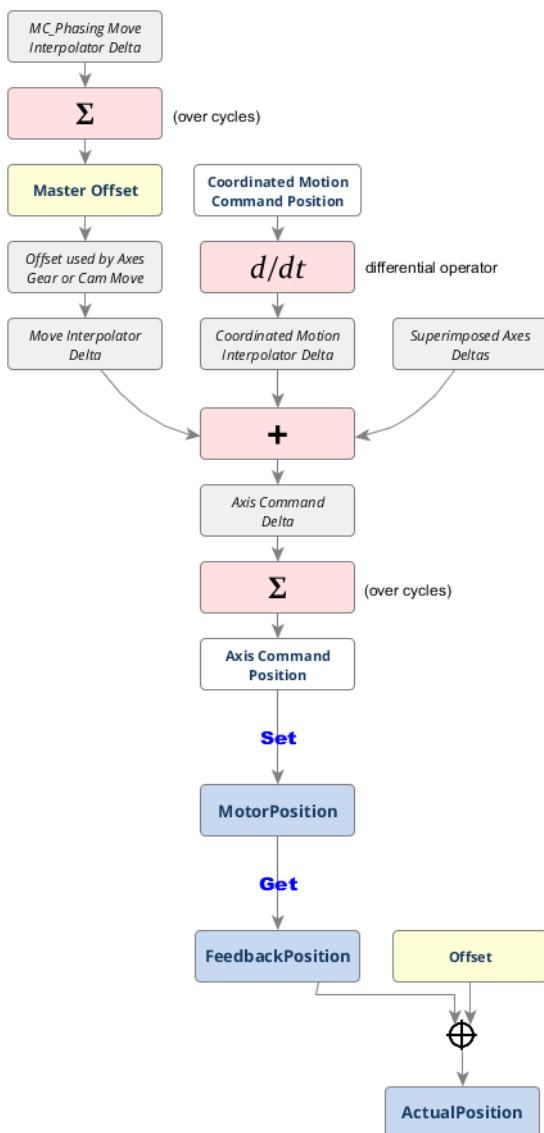

Figure 14-13: How Actual Position is Calculated



14.2.3 NormalCmdPos

This is the command position generated by the Normal Interpolator when interpolating a single axis move or a slave move.

14.2.4 PhaseCmd Pos

This is the command position generated by the Phasing Interpolator when interpolating a MC_Phasing master phase shift.

It is incorporated in the generation of the NormalCmdPos when interpolating a slave move.

14.2.5 SuperimposedCmdPos

This is the command position generated by the Superimposed Interpolator when interpolating a MC_Superimp move

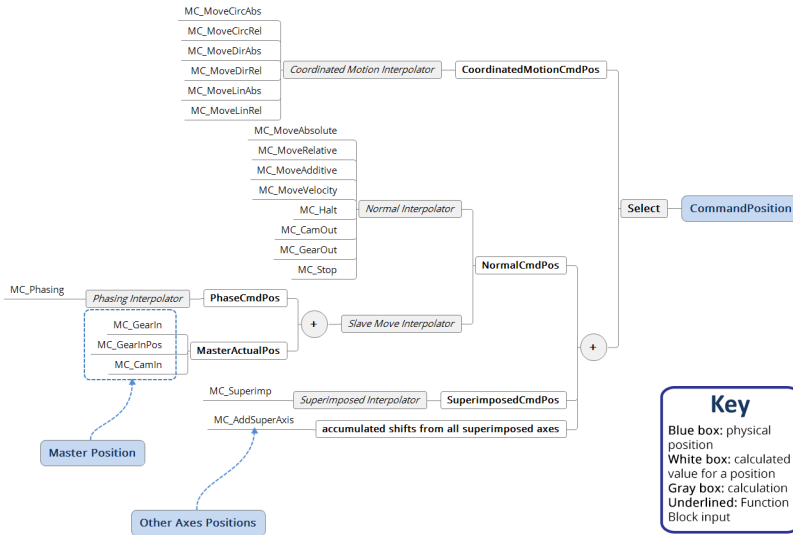

Figure 14-14: Calculated PLCOpen Axis Position Data

14.2.5.0.1.1 AXIS_REF Structure

The PLCOpen specification indicates a "Structure" (→ p. 703) used for identifying the axis at a function block input.

AXIS_REF contains these members:

Member	Type	Description
AXIS_NUM	INT	The axis number.
AXIS_ENGINE	UINT	Reserved. Do not modify this variable or rely on its value.

See "Modify PLCOpen Axis" (→ p. 166) about Axis Number.

You have to create and initialize this data structure in your application.

14.2.5.0.2.2 Axis Velocity Data

Velocity data are related to PLCOpen Axis.

14.3 Actual Velocity

This is the rate of change of the actual position of the axis read from the drive interface which is read from the feedback device:

$$\text{Feedback device} > \text{Drive interface} > \text{ActualPosition}(n) - \text{ActualPosition}(n-1)$$

14.4 Command Velocity

This is the rate of change in command position.

- This velocity is tied to the Status output of the MC_Power function block.
 - Since command velocity is the rate change of command position:
 - Status = 1: The rate of change of the command position sent to the drive interface to command the axis.
 - Status = 0: The command velocity tracks the Actual Velocity.

14.4.0.0.1.1 Buffer Modes

Some of the function blocks (FBs) have an input called BufferMode.

- With this input, the FB can either work in a Non-buffered mode (default behavior) or in a buffered mode.
 - The difference between those modes is when they start their action:
 - A non-buffered mode command acts immediately, even if this interrupts another motion.
 - A buffered mode command waits until the current FB sets its **Done** output (or **InPosition** or **InVelocity**).

This table lists the buffer modes that can be specified at the BufferMode input of the function blocks.

Value	Buffer Mode	Short Name	Description
0	BM_ ABORTING	Abort	A move that specifies Abort: <ul style="list-style-type: none"> • Aborts the active move. • Removes the next move from the queue. • Immediately becomes the active move and begins executing.
1	BM_ BUFFERED	Buffer	One of these events can happen with a move that specifies Buffer: <ul style="list-style-type: none"> • Case 1: If there is no active move, this move immediately becomes the active move and begins executing. • Case 2: If there is an active move but no next move queued, this move is queued as the next move. <ul style="list-style-type: none"> • It begins executing when the active move has completed and decelerated to zero velocity. • Case 3: If there is an active move and a queued next move, this move does not execute but returns the error queue full at the ErrorID output.
2	BM_ BLENDING_ PREVIOUS	Blend to Previous	A move specifying Blend-to-Active behaves the same as Buffer in Cases 1 and 3 . <ul style="list-style-type: none"> • In Case 2, this move is queued as the next move. • The active move stays at its programmed velocity to its endpoint. • When the active move reaches its endpoint, this move becomes active and begins to accelerate or decelerate to its programmed velocity.
3	BM_ BLENDING_ NEXT	Blend to Next	A move specifying Blend-to-Next behaves the same as Buffer in Cases 1 and 3 . <ul style="list-style-type: none"> • In Case 2, this move is queued as the next move. • When the expected time is reached, the active move begins to accelerate or decelerate so it reaches this move's programmed velocity at the time the active move reaches its endpoint.

Value	Buffer Mode	Short Name	Description
4	BM_BLENDING_LOW	Blend to Low	<p>A move specifying Blend-to-Low behaves like Blend-to-Active if the active move's velocity is lower than this move's velocity.</p> <ul style="list-style-type: none"> It behaves like Blend-to-Next if this move's velocity is lower than the active move's velocity.
5	BM_BLENDING_HIGH	Blend to High	<p>A move specifying Blend-to-High behaves like Blend-to-Active if the active move's velocity is higher than this move's velocity.</p> <ul style="list-style-type: none"> It behaves like Blend-to-Next if this move's velocity is higher than the active move's velocity.

ⓘ IMPORTANT

The **MC_BUFFER_MODE_BLENDING_NEXT** and **MC_BUFFER_MODE_BLENDING_HIGH** buffer modes may increase the acceleration to meet the target position at the specified velocity. The acceleration is automatically re-calculated to reach the target position at the specified velocity if the specified acceleration is too small to reach the target velocity within the specified distance.

Example: These absolute position moves are commanded:
 Move #1:

Position = 90, Velocity = 180, Accel = 360

Move #2: (with Blending High or Blending Next)

Position = 360, Velocity = 360, Accel = 360

To reach velocity = 360 within a distance of 90, the acceleration must be 720. The function block automatically calculates and applies an acceleration of 720 to reach the target position at the specified velocity:

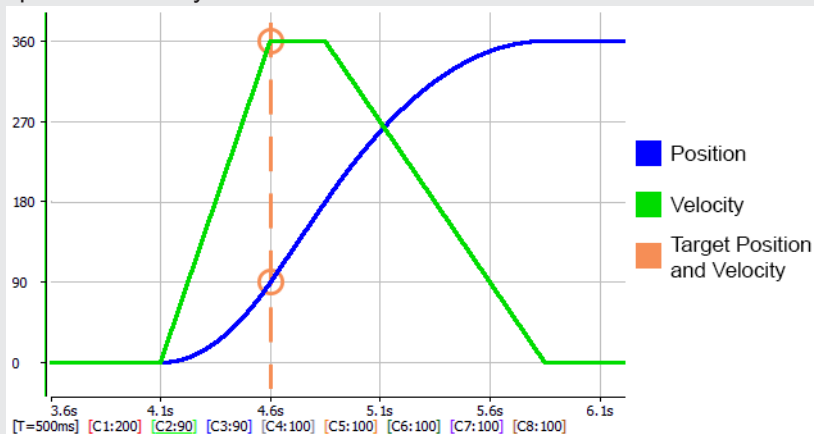

14.4.0.0.2.2 Move Types

MoveID	Description	Related FB
0	No move	
1	Distance move	<ul style="list-style-type: none"> MC_MoveRelative MC_MoveSuperimp MC_Phasing
2	Position move	MC_MoveAbsolute

MoveID	Description	Related FB
3	Velocity move	MC_MoveVelocity
4	Halt move	MC_Halt
5	Gear-in move	MC_GearIn
6	Gear-out move	MC_GearOut
7	Reference move	MC_Reference
8	Stop move	MC_Stop
9	Gear-in pos. move	MC_GearInPos
10	Cam profile move	MC_CamIn
11	Cam-out move	MC_CamOut

14.4.0.0.3.3 Profile Generator

Each servo axis has these Profile Generators which has its own queue:

- Normal - handles all single-axis and master-slave moves.
- Superimposed - handles MC_MoveSuperimp moves exclusively.
- Phasing - handles MC_Phasing phase shifts exclusively.

The Profile Generators allow these types of moves to execute simultaneously.

14.4.0.0.4.4 Queuing

A queuing mechanism is provided for all PLCopen motion function blocks including single-axis and master/slave moves.

- This mechanism allows the application to queue a next move while the active move is executing.
- The Buffer Modes define the transition from the active move to the next move.

14.4.0.0.5.5 S-curve and Trapezoidal Acceleration / Deceleration

14.5 S-curve

If the Jerk input of a motion function block is non-zero, S-curve acceleration / deceleration is used.

- The Acceleration input specifies the maximum acceleration / deceleration reached during changes in velocity.
 - The Jerk input specifies the constant rate of change of acceleration and deceleration used to cause a smooth transition to and from maximum acceleration / deceleration.
- The Deceleration input is unused.

14.6 Small Jerk Acceleration

The Figure: "**Small Jerk Acceleration**" is a velocity plot of the acceleration of a move when Jerk is a small value.

The smaller the Jerk value, the more gradual the rate of change of acceleration / deceleration when transitioning from one velocity to another.

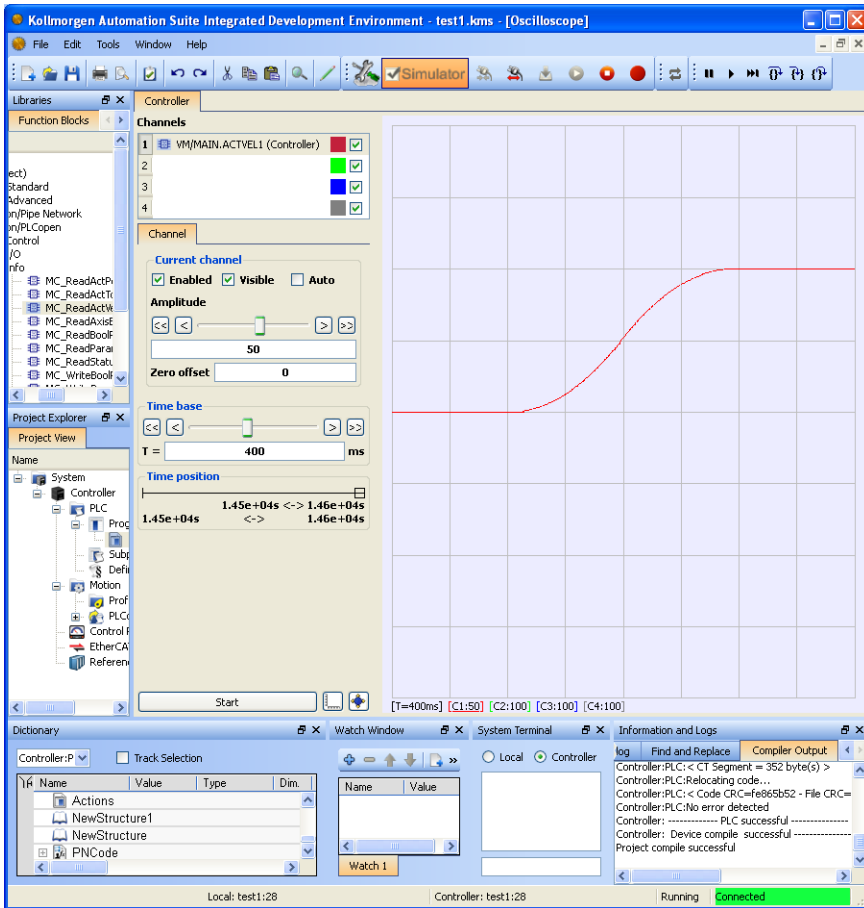

Figure 14-15: Small Jerk Acceleration

14.7 Large Jerk Acceleration

This Figure: "Large Jerk Acceleration" is a velocity plot of the acceleration of a move when Jerk is a large value.

The larger the Jerk value, the more abrupt the rate of change of acceleration / deceleration when transitioning from one velocity to another.

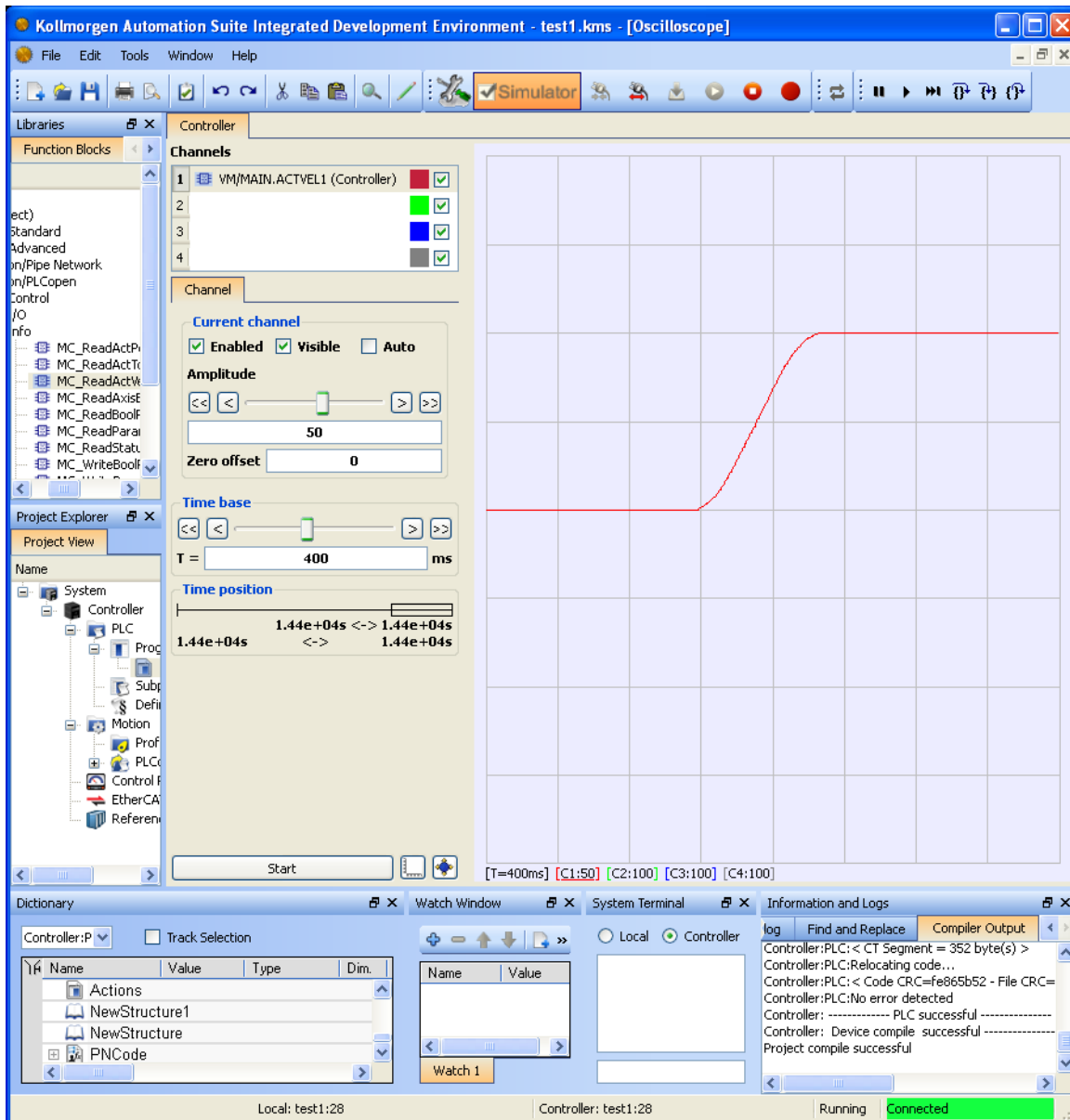

Figure 14-16: Large Jerk Acceleration

14.8 Trapezoidal

If the Jerk input of a motion function block is zero, trapezoidal acceleration / deceleration is used.

- The Acceleration input specifies the linear acceleration rate.
- The Deceleration input specifies the linear deceleration rate.

This Figure: "**Trapezoidal Acceleration**" is a velocity plot of the acceleration of a move when trapezoidal acceleration is used (Jerk = 0 (zero)).

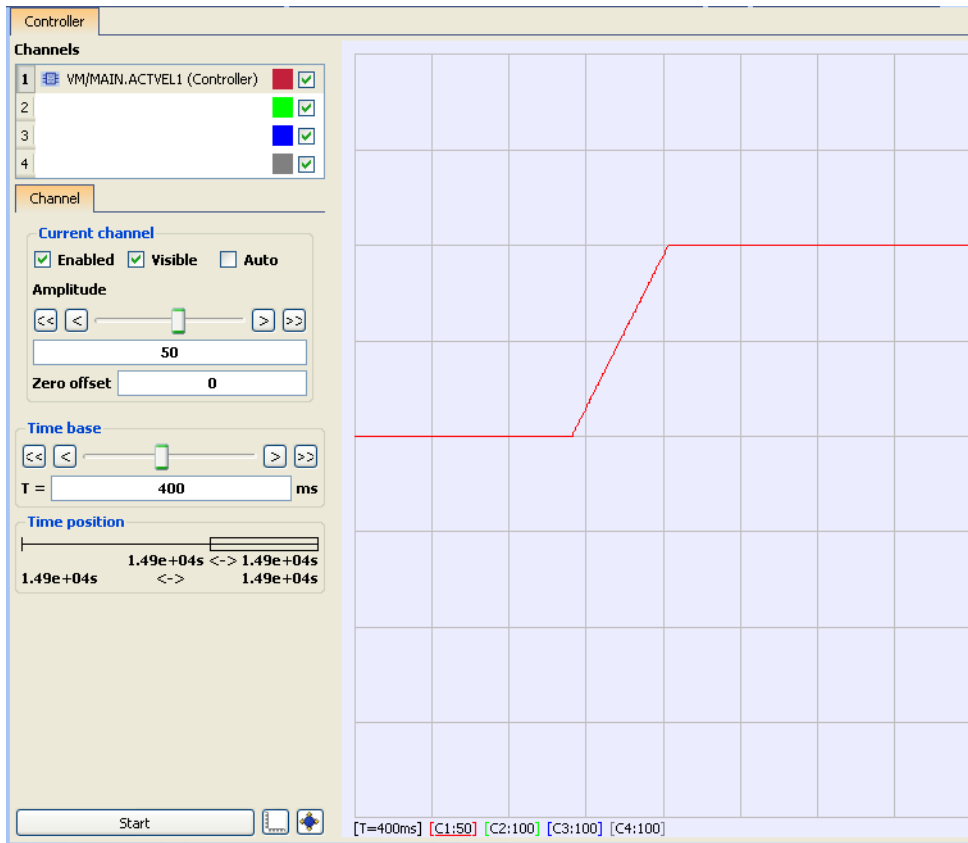

Figure 14-17: Trapezoidal Acceleration

14.8.0.0.1.1 Function Block Acceleration and Jerk Parameters

Acceleration is the first derivative of velocity, or the rate of change of velocity.

- The acceleration rate specifies how quickly an axis may change its velocity.
- Jerk is the second derivative of velocity, or the rate change of acceleration.
 - The jerk rate therefore specifies how quickly an axis may change its acceleration.
 - Jerk controls how abrupt the axis begins and ends the acceleration and deceleration curves.

See "Motion Profile" (→ p. 724).

14.9 Rules

The amount of time an axis takes to change its velocity from one velocity to another is a function of both acceleration and jerk.

The larger the values of acceleration and jerk, the more quickly an axis will attain its programmed velocity.

These are generalizations that can be made about acceleration, jerk, and their relationships to each other.

- The higher the acceleration rate, the faster the axis obtains programmed velocity.
- The higher the jerk rate, the more responsive the axis is to changes in command.
- Excessive jerk typically, and more noticeably, contributes to harsh acceleration rather than excessive acceleration.
- Too low of a jerk value contributes to slow axis responsiveness to changing commands.
 - Lower jerks tend to soften the beginning and end of acceleration.
 - Higher jerks sharpen the beginning and end of acceleration.
- Typically, Jerk > Acceleration; Acceleration > Velocity.

14.10 Methods

There are several methodologies to determine proper acceleration and jerk values.

- These methodologies allow calculation of parameters given different desired profiles.
 - Once parameters are calculated, they can be modified to obtain the designated results.
- Acceleration and Jerk values are subject to the limits of ratios.

14.10.1 Example 1

1/3, 1/3, 1/3 time, given velocity and time.

```
Acceleration = (3 * Velocity) / (2 * time)
Jerk = 3 * Acceleration / time
```

- This allows you to calculate an appropriate acceleration and jerk for an axis acceleration / deceleration profile to:
 - Jerk or ramp acceleration up for 1/3 of the time.
 - Accelerate 1/3 of the time.
 - Ramp acceleration down 1/3 of the time.
- Time is the desired amount of time to reach desired velocity.
 - This is the time to change velocity, not the time to complete the move.

14.10.2 Example 2

1/3, 1/3, 1/3 velocity, given velocity and time.

```
Acceleration = (5 * Velocity) / (3 * time)
Jerk = (3 * Acceleration ^2) / (2 * velocity)
```

- This allows you to calculate an appropriate acceleration and jerk, if you would like an axis acceleration / deceleration profile to:
 - Jerk or ramp acceleration up for 1/3 of the velocity change.
 - Accelerate 1/3 of the velocity change.
 - Ramp acceleration down 1/3 of the velocity change.
- Where velocity is the desired velocity change, and time is the desired amount of time to reach the desired velocity change.
 - This is the time to change velocity, not the time to complete the move.

14.10.3 Example 3

Calculate jerk, given velocity, acceleration, and time.

```
Jerk = (2 * Acceleration) / (time - (velocity / (2 * acceleration)))
```

If you know the maximum acceleration of the axis and want to calculate a jerk given the velocity and time, use this equation.

This is the time to change velocity, not the time to complete the move.

14.11 Limitations on Acceleration and Jerk

The ratios of Acceleration to Jerk and Velocity to Jerk are limited on most function blocks.

- The ratio of Velocity to Acceleration must be less than **20**.

- A value of 20 suggests a time to accelerate to velocity of approximately 20 seconds, assuming infinite jerk.
- As jerk is decreased, this acceleration time is increased.
- The ratio of Acceleration to Jerk must be less than 2.
 - A value of 2 suggests the time to jerk to the acceleration rate is approximately 2 seconds.

14.11.0.0.1.1 Velocity Compensation

Velocity compensation is a value that is added to the master actual position to predict where the master will be when the new slave command position is sent to the slave.

- The compensation is used to get rid of the delay in reading the master's feedback.
- This involves prediction about where the master will be, so there is likely some small error in the prediction.

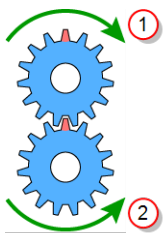

Figure 14-18: Ideal 1:-1 Gearing

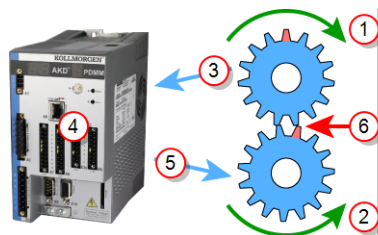

Figure 14-19: Real-world 1:-1 Gearing

1. Master
2. Slave
3. Feedback
4. 1+ cycle delay
5. Slave command position
6. Out of sync

Figure 14-18 and Figure 14-19 represent a 1:-1 gearing.

- Figure 14-18 is ideal gearing where the master and slave are always perfectly synchronized.
 - When the red tooth of the master gear is at the top, the red tooth of the slave gear is also at the top.
- Figure 14-19 is a real-world gearing example.
 - There is a time delay in reading the master feedback position, communicating that value to the controller, and the controller communicating the new command position to the slave axis.
 - This delay causes the slave to lag behind in its position.
 - This is demonstrated by the slave's read tooth being slightly out of position.

To compensate for the delay, we want to predict where the master axis will be when the new slave position is applied to the slave. This is the purpose of the velocity compensation.

- Velocity compensation is controlled by two axis parameters:
 - "Velocity Compensation Factor" (→ p. 776)
 - "Velocity Compensation Filter" (→ p. 777)
- Both parameters are properties of master axes.
- When an axis is synchronized to a master via camming or gearing, the PLCopen motion engine uses these two properties of the master axis to predict where the master axis will be in the next motion cycle.
- The PLCopen motion engine then uses this predicted master position to calculate the new slave position.

14.12 Velocity Compensation Factor

The **Velocity Compensation Factor** (Axis Parameter 1009) is the number of motion cycles to compensate for the feedback latency.

- It should be set equal to the number of motion cycles between when the feedback device acquires the position and when the motion controller processes the position feedback.
- A value of 0 indicates no compensation is applied.
- The larger the value of Velocity Compensation Factor, the more prediction takes place and the more prediction error there will be.

- For physical axes, the value for Velocity Compensation Factor is normally 1 or 2.
 - Some feedback devices or drives may require larger values.
- For virtual masters, the value is usually be 0.
 - Virtual masters do not need compensation since their position is always known by the controller.

14.13 Velocity Compensation Filter

The **Velocity Compensation Filter** (Axis Parameter 1010) is a way to filter noisy feedback systems and/or masters that may have jitter due to servo action.

- Numerically, the Velocity Compensation Filter is the number of motion cycles over which a previously calculated compensation is applied.
 - This helps smooth noisy systems.
- The default value for Velocity Compensation Filter is 1.
 - No filtering takes place.
 - All corrections are applied in a single cycle.
- Larger values smooth the noise, but can also cause the prediction of the master position to be further off by what is characterized as additional following error or phase delay.
- Balancing between the level of noise and the amount of phase delay is application specific and is best determined by experimentation.
- Good values typically lie in the range of 1 to 5.

See Also

"Axis Parameters" (→ p. 749)

14.13.0.0.1 Function Blocks - General Rules

The general rules for [PLCopen](#) are:

- "Active Output" (→ p. 777)
- "Behavior of Busy Output" (→ p. 778)
- "Behavior of CommandAborted Output" (→ p. 778)
- "Behavior of Done Output" (→ p. 778)
- "Error Handling Behavior" (→ p. 778)
- "Input Parameters" (→ p. 778)
- "Inputs Exceed Application Limits" (→ p. 780)
- "Missing Input Parameters" (→ p. 780)
- "Output Exclusivity" (→ p. 780)
- "Output Status" (→ p. 781)
- "Sign Rules" (→ p. 781)

14.13.0.0.2.1 Active Output

The **Active** output is set at the moment the function block takes control of the motion of the respective axis.

14.14 Coordinated Motion

Use this table to determine the state of the Busy and Active outputs when transitioning from one move to the next.

FB Output	First Move	Second Move
Busy	False	True
Active	False	False
Done	True*	False

*This output is False if the move is interrupted by a MC_GrpHalt, MC_GrpStop or if the second move's buffer mode is **Aborting**.

14.14.0.0.1.1 Behavior of Busy Output

The **Busy** output indicates that the function block is still working, with new output values to be expected.

- **Busy** is SET at the rising edge of **Execute** and RESET when one of the outputs (e.g., **Done**, **Aborted**, or **Error**) is set.
- It is recommended that this function block is kept in the active loop of the application program for at least as long as **Busy** is TRUE, because the outputs can still change.
- For one axis, several function blocks can be busy, but only one can be active at a time.
 - Exceptions are **MC_SuperImposed** and **MC_Phasing**, where more than one function block related to one axis can be active.

14.14.0.0.2.2 Behavior of CommandAborted Output

- **CommandAborted** is set when a commanded motion is interrupted by another motion command.
- The reset-behavior of **CommandAborted** is similar to **Done**.
 - When **CommandAborted** occurs, the other output signals (e.g., **InVelocity**) are reset.

14.14.0.0.3.3 Behavior of Done Output

The **Done** output (as well as **InGear**, **InSync**) is set when the commanded action has been completed successfully.

- With multiple function blocks working on the same axis in a sequence, this applies:
 - When one movement on an axis is interrupted with another movement on the same axis without having reached the final goal, **Done** of the first function block is not set.

When a motion command is executed, these are the possible outcomes:

- It completes successfully.
 - At that time, the **Done** output goes high.
- It is aborted prior to completing by a subsequent motion command.
 - At that time, the **CommandAborted** output goes high.
- It encounters an error prior to completing or an invalid input is specified.
 - At that time, the **Error** output goes high.

These outputs stay in this state until that motion function block is executed again.

At that time, the **Done**, **CommandAborted** and **Error** outputs goes low and the **Busy** output goes high, provided all the inputs are valid.

14.14.0.0.4.4 Error Handling Behavior

Two outputs deal with errors that can occur while executing a function block.

These outputs are defined as:

- **Error**: The rising edge of **Error** informs you that an error occurred during the execution of the function block.
- **ErrorID**: Error number.
- **Done**, **InVelocity**, **InGear**, and **InSync** mean successful completion.
 - These signals are logically exclusive to **Error**.
- Instance errors do not always result in an axis error.
 - Some bring the axis to **StandStill**.

14.14.0.0.5.5 Input Parameters

Unless otherwise specified in the function block's description, the input parameters are read with the rising edge of the **Execute** input.

The input parameters are:

The PLCopen function / function block input parameters are:

- "PLCopen Function Blocks with Execute" (→ p. 779)
- "PLCopen Function Blocks with Enable" (→ p. 779)
- "PLCopen Functions with Input Parameter En" (→ p. 780)

14.15 PLCopen Function Blocks with Execute

- These FBs initiate execution on the rising edge of **Execute**.
- Execution continues until completion independent of the **Execute** value (or values) following initiation.
- Once execution is complete, the function block can be rearmed or reengaged by introducing another rising edge of **Execute**.

NOTE

Dual-Core limitation: Consecutive calls to the function block with repeating **Execute** values in the same cycle return an error code "76" (→ p. 747).

Function Block	Description
MC_ AbortTrigger	A positive transition of this input causes this function block to execute.
MC_SetPosition	
MC_SyncSlaves	
MC_ TouchProbe	
MC_CamIn	A positive transition of this input requests to queue the move.
MC_CamOut	
MC_GearIn	
MC_GearInPos	
MC_GearOut	
MC_Halt	
MC_ MoveAbsolute	
MC_ MoveAdditive	
MC_ MoveRelative	
MC_ MoveSuperimp	
MC_ MoveVelocity	
MC_ CamTblSelect	A positive transition of this input reads and initializes the specified profile.
MC_Phasing	A positive transition of this input requests to queue the phase shift move.
MC_Reference	A positive transition of this input requests to queue the reference move and arm the reference trigger events.
MC_Stop	A positive transition of this input initiates a stop move. While this input is held high, no other move can be queued for this axis.
MC_ WriteBoolPar	A positive transition of this input writes the specified parameter.
MC_WriteParam	

14.16 PLCopen Function Blocks with Enable

These FBs continuously execute every PLC cycle, as long as the Enable remains high.

Function Block	Description
MC_Power	<ul style="list-style-type: none"> If this input is high and the drive is currently disabled, this function block requests to close the servo loop and enable the drive. If this input is low and the drive is currently enabled, this function block requests to open the servo loop and disable the drive.
MC_ReadActPos	
MC_ReadActVel	When this input is high, the axis's actual velocity is returned.
MC_ReadAxisErr	When this input is high, the axis's error status is returned.
MC_ReadBoolPar	When this input is high, the specified parameter is read.
MC_ReadParam	
MC_ReadStatus	When this input is high, the function block outputs is updated.
MC_SetOverride	When this input is high, the override factors is written.

14.17 PLCopen Functions with Input Parameter En

This is similar to ENABLE on function blocks.

Functions are expected to complete in one cycle.

See "Differences between Functions and Function Blocks" (→ p. 714).

Function	Description
MC_AddSuperAxis	When this input is high, the specified axis is added to the superimposed axis list of the receiving axis.
MC_CreatePLCAxis	When this input is high, a PLCopen axis is created.
MC_EStop	When this input is high, an E-stop is generated for the specified axis.
MC_InitAxis	When this input is high, the specified axis is initialized.
MC_RemSuperAxis	When this input is high, the specified axis is removed from the superimposed axis list for the specified receiving axis.
MC_ResetError	When this input is high, the specified axis's errors is reset.

14.17.0.0.1.1 Inputs Exceed Application Limits

If a function block is commanded with parameters which result in a violation of application limits, the instance of the function block generates an error.

14.17.0.0.2.2 Missing Input Parameters

If any input parameter of a function block is missing (**open**), the compiler generates an error.

14.17.0.0.3.3 Output Exclusivity

If the **Execute** input of a function block is set TRUE, either the **Busy**, **Done**, **Error**, or **CommandAborted** outputs must also be set TRUE.

- These outputs are mutually exclusive, meaning that a function block may have only one of them set TRUE at any time.
- The output of the MC_GearOut function block is an exception to this exclusivity rule.
- The MC_GearOut is done when the slave axis is disengaged from the master axis.
- When completed, the MC_GearOut remains busy and active until it is aborted by a different motion function block.
- The MC_GearOut function block represents an exception to the exclusivity rule as the **Done** and **Active** outputs can be TRUE at the same time.

14.17.0.0.4.4 Output Status

The **Done**, **Error**, **ErrorID** and **CommandAborted** outputs are reset with the next rising edge of **Execute**.

If a function block receives a new **Execute** before it finishes (as a series of commands on the same instance), the function block does not return any feedback, like **Done** or **CommandAborted**, for the previous action.

14.17.0.0.5.5 Sign Rules

- Velocity, Acceleration, Deceleration and Jerk are **always positive** values.
- Position and Distance can be **positive or negative**.

14.17.0.0.6 PLCopen State Machine

This diagram normatively defines according to PLCopen the behavior of the axis at a high-level when multiple motion control function blocks are simultaneously activated.

- This combination of motion profiles is useful in building a more complicated profile or in handling exceptions within a program.
 - In real implementations there can be additional states defined at a lower level.
- The basic rule is that motion commands are always taken sequentially, even if the PLC has the capability of real parallel processing.
 - These commands act on the state diagram of the axis.
- The axis is always in one of the defined states.
 - A change of state is reflected immediately when issuing the corresponding motion command.
 - The response time of immediately is system dependent.

The defined seven states are:

- Continuous Motion
- Discrete Motion
- Error Stop
- Homing
- Stand Still
- Stopping
- Synchronized Motion

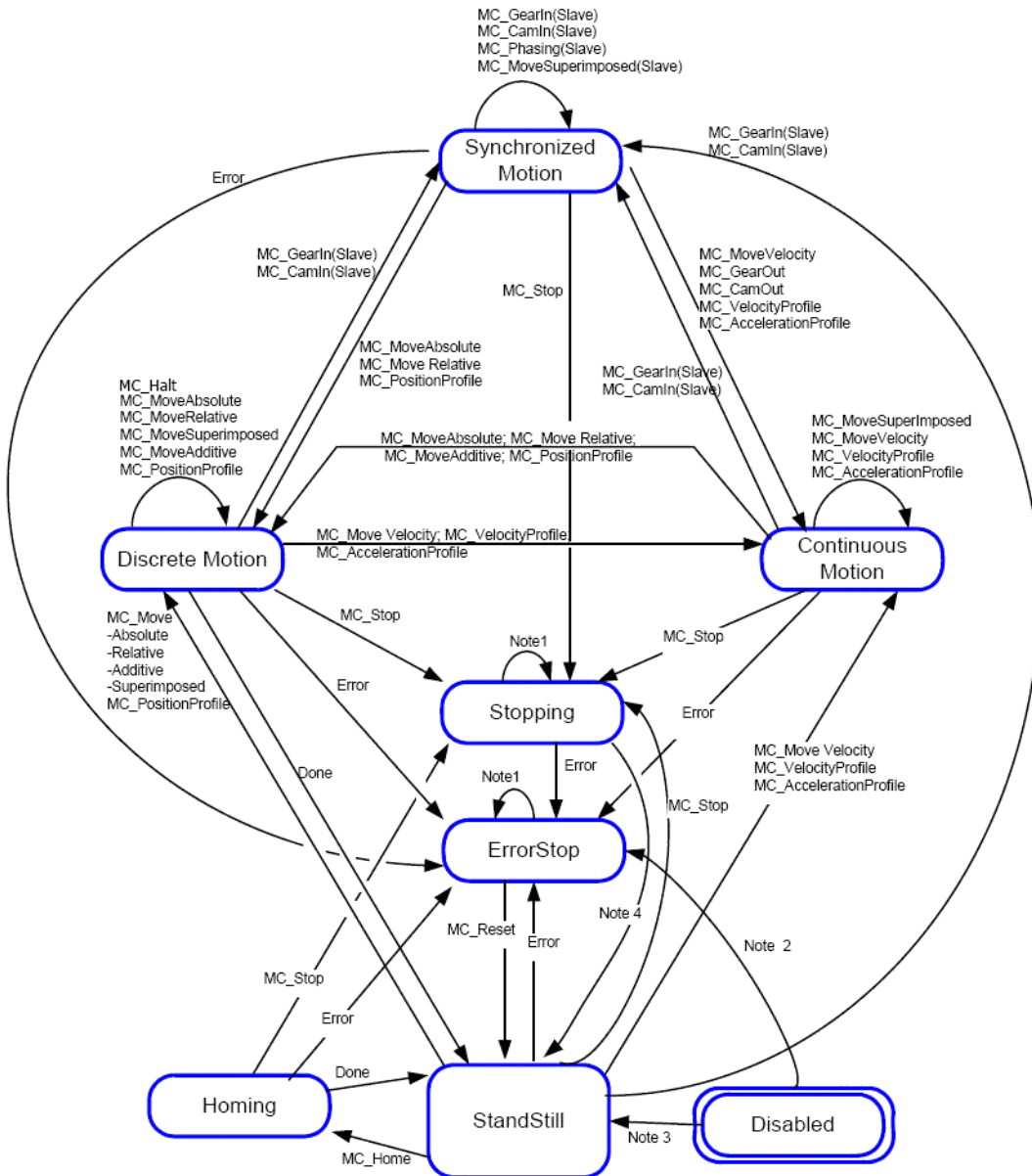

Figure 14-20: Motion State Machine (PLCopen)

Notes

- In the **ErrorStop** or **Stopping** state, all function blocks can be called, although they are not executed. The exceptions are MC_Reset and Error which generate the transition to **StandStill** or **ErrorStop** respectively.
- MC_Power FB is called with Enable=TRUE and there is an error in the Axis.
- MC_Power FB is called with Enable=TRUE and there is **no** error in the Axis.
- MC_Stop.Done **and not** MC_Stop Execute.

14.17.1 State Machine for Multi-axes Motion Control

The diagram is focused on a single-axis.

- The multi-axes function blocks (e.g., MC_CamIn, MC_GearIn, or MC_Phasing) can be looked at, from a state diagram point of view, as multiple single-axes all in specific states.
- Example: The CAM-master can be in the state **Continuous Motion**.

- The corresponding slave is in the state **Synchronized Motion**.
- Connecting a slave axis to a master axis has no influence on the master axis.

A normal procedure starts in **StandStill**.

- In this state the power can be switched on per axis (via the MC_Power command).
 - Access the **Homing** state (via the issue of the command Home per axis). This returns to **StandStill** after normal completion.
 - From here, transfer an axis to either **Discrete Motion** or **Continuous Motion**.
 - Via the **Stopping** state you can return to **StandStill**.
 - **ErrorStop** is a state to which the axis transfers in case of error.
 - Via a (manual) MC_ResetError command, return to **StandStill**.
 - From this state, the machine can be moved to an operational state again.

The States define the functionality of the function blocks.

- Function Blocks not listed in the State Diagram do not affect the state of the axis.
 - This means that, whenever they are called, the state does not change.
 - They are:
 - MC_CamTblSelect
 - MC_ReadActPos
 - MC_ReadAxisErr
 - MC_ReadBoolPar
 - MC_ReadParam
 - MC_ReadStatus
 - MC_WriteBoolPar
 - MC_WriteParam

14.17.1.0.1.1 Disabled State

The **Disabled** state describes the initial state of the axis.

Disable means power off without error.

- In this state, the movement of the axis is not influenced by the FBs.
 - The axis feedback is operational.
 - If the MC_Power FB is called with Enable=TRUE while being in **Disabled**, this leads to either:
 - **Standstill** if there is no error inside the axis.
 - **ErrorStop** if an error exists.
 - Calling **MC_Power** with Enable=FALSE in any state, the axis goes to the state **Disabled**, either directly or via any other state.
 - If a motion generating FB controls an axis while the **MC_Power** FB with Enable=FALSE is called, the motion generating FB is aborted (CommandAborted).

14.17.1.0.2.2 ErrorStop State

The **ErrorStop** state is the axis goes to a stop, if possible.

- No further FBs are accepted until a reset has been done from the **ErrorStop** state.
- The transition Error refers to errors from the axis and axis control, and not from the function block instances.
- These axis' errors are reflected in the output of the function blocks FB instances errors.
- Issuing MC_Home in any other state than **StandStill** goes to **ErrorStop**, even if MC_Home is issued from the **Homing** state itself.
- **ErrorStop** is valid as highest priority and applicable in case of an error.
 - The axis can have either power enabled or disabled, and can be changed via MC_Power.
 - However, as long as the error is pending, the state remains **ErrorStop**.

14.17.1.0.3.3 From StandStill to Stopping

StandStill is power on without an error.

- Calling the FB MC_Stop in state **StandStill** changes the state to **Stopping** and back to **Standstill** when Execute = FALSE.
- The **Stopping** state is kept as long as the input Execute = TRUE.
- The **Done** output is set when the stop ramp is finished.

14.17.1.0.4 Program a Multi-Core Controller

A multi-core controller operates slightly differently to take advantage of the extra performance provided by a multi-core CPU.

Consequently, there are some differences in programming a multi-core controller from programming a single-core controller.

This page lists those differences.

14.17.1.0.5.1 Cached Data

A multi-core controller gains most of its performance by running PLC code and motion code at the same time.

To avoid [race conditions](#), function blocks that read motion data reports the data that the motion code used or calculated during the last cycle.

14.17.2 Function Blocks - Return Cached Data

[List of function blocks that return cached data](#)

- MC_AddSuperAxis
- MC_ClearFaults
- MC_EStop
- MC_GrpReadActAcc
- MC_GrpReadActPos
- MC_GrpReadActVel
- MC_GrpReadBoolPar
- MC_GrpReadCmdPos
- MC_GrpReadCmdVel
- MC_GrpReadError
- MC_GrpReadParam
- MC_GrpReadStatus
- MC_GrpWriteBoolPar
- MC_GrpWriteParam
- MC_MoveContVel
- MC_Power
- MC_ReadActPos
- MC_ReadActVel
- MC_ReadAxisErr
- MC_ReadBoolPar
- MC_ReadParam
- MC_ReadStatus
- MC_RemSuperAxis
- MC_ResetError
- MC_SetPos
- MC_SetPosition - Deprecated
- MC_StopRegist
- MC_WriteParam
- MAxisAddTq
- MAxisCmdPos
- MAxisFBackPos
- MAxisGenEN
- MAxisGenIsRdy
- MAxisGenPos

- MLAxisPipePos
- MLAxisReadActPos
- MLAxisReadGenStatus
- MLAxisReadTq
- MLAxisReadVel
- MLAxisReAlgnRdy
- MLAxisStatus
- MLAxisStop
- MLAxisTimeStamp
- MLBklReady
- MLBklReadOutVal
- MLCNVConECAT
- MLCNVConnect
- MLCNVConnectEx
- MLCNVDisconnect
- MLMotionStatus
- MLPhaReadActPhase
- MLPmpStatus
- MLSyncWriteDeltaS
- MLTrigClearFlag
- MLTrigIsTriggered
- MLTrigReadPos
- MLTrigReadTime
- MLTrigSetEdge
- Motion / Pipe Network - Comparator
- Motion / Pipe Network - Integrator

14.17.2.0.1.1 Call Function Blocks Multiple Times in the Same Cycle

A given function block can usually be called multiple times without causing problems when using a single-core controller.

Example

It is possible to call **MC_MoveVelocity** multiple times to start velocity moves on multiple axes.

Set the **Execute** input to **False** between every call to start a new velocity move.

- When doing this, the ability to monitor the status of the velocity moves is lost because the axis parameter is changed for each call.
- If there is no concern with monitoring the status of the velocity moves, call **MC_MoveVelocity** any number of times in a given cycle.

Function blocks that start a motion-related action need to avoid race conditions when using a multi-core controller.

The function blocks have to save argument data so that calculations and error detection can be determined during the next controller cycle.

There are two consequences to this:

- With the possible exception of the **multicoreFbExecuteDuplicateValueInCycle** error "76" (→ p. 747), the **Error** and **ErrorID** outputs report no error on the first cycle.
 - The **Error** and **ErrorID** outputs reports their status in the next VM cycle.
- The function block cannot be called with the same Execute state twice in a single VM cycle.
 - If a function block is called with the same Execute state twice in a single VM cycle, a **multicoreFbExecuteDuplicateValueInCycle** error "76" (→ p. 747) is returned immediately.

14.17.3 Function Blocks - Start Motion-related Actions

[List of function blocks that start motion-related actions](#)

- MC_AbortTrigger
- MC_AddAxisToGrp
- MC_AxisSetDefaults
- MC_CamIn
- MC_CamOut
- MC_CamResumePos
- MC_CamStartPos
- MC_GearIn
- MC_GearInPos
- MC_GearOut
- MC_GrpDisable
- MC_GrpEnable
- MC_GrpHalt
- MC_GrpReset
- MC_GrpSetPos
- MC_GrpStop
- MC_Halt
- MC_MachRegist
- MC_MarkRegist
- MC_MoveAbsolute
- MC_MoveAdditive
- MC_MoveCircAbs
- MC_MoveCircRel
- MC_MoveContVel
- MC_MoveDirAbs
- MC_MoveDirRel
- MC_MoveLinAbs
- MC_MoveLinRel
- MC_MoveRelative
- MC_MoveSuperimp
- MC_MoveVelocity
- MC_Phasing
- MC_Reference
- MC_RemAxisFromGrp
- MC_SetPos
- MC_Stop
- MC_SyncSlaves
- MC_TouchProbe
- MC_UngroupAllAxes

14.17.4 EtherCAT Motion Bus Concepts

To exchange data between the controller (master) and the devices (slaves), the KAS Runtime relies on the EtherCAT motion bus. This communication is done in two modes: cyclic and non-cyclic (mailbox).

In **cyclic mode**, a single frame containing the data of all slaves (input and output) travels along all slaves and goes back to the master. Data is read and/or written on the fly by each slave.

The slave device input and output data definitions are:

- Outputs are written by the master and read by the slave device.
- Inputs are written by the slave device and read by the master.

14.17.4.1 EtherCAT Process Image

This cyclic frame is called the EtherCAT Process Image.

- It contains the Process Data, which is defined during network initialization.
- The cyclic data is grouped in predefined blocks called Process Data Objects or PDO.

NOTE

PDOs contain real-time cyclic data which is deterministic.
 Non-cyclic data is not deterministic and is defined by Service Data Objects (ScDO).

14.17.4.1.1 References

- EtherCAT Specification V1.0 - see <http://www.ethercat.org> in the Member Area - Downloads.
- Büttner, H.; Janssen, D.; Rostan, M. (2003), [EtherCAT - the Ethernet fieldbus](#), (PDF), PC Control Magazine 3: 14-19.

**14.17.4.2 EtherCAT Functional Principle**

Automation networks are characterized by short data-length per node, typically less than the minimum payload of an Ethernet frame. Using one frame per node per cycle leads to low bandwidth utilization and thus to poor overall network performance.

EtherCAT takes a different approach, called **processing on the fly** (see (→ # 793, EtherCAT Implementation) for more information).

- With EtherCAT, the Ethernet packet or frame is no longer received, and then interpreted and copied as process data at every node.
- Instead, the EtherCAT slave devices read the data addressed to them while the telegram passes through the device.
 - Input data is inserted while the telegram passes through.
- The frames are only delayed by a fraction of a microsecond in each node, and many nodes - typically the entire network - can be addressed with just one frame.

14.17.4.3 EtherCAT Features

EtherCAT is characterized by outstanding performance, very simple wiring, and openness to other protocols. EtherCAT sets new standards where conventional fieldbus systems reach their limits:

- 1000 I/Os in 30 μ s.
- Optionally twisted-pair cable or optical fiber.
- Optimum vertical integration (thanks to Ethernet and Internet technologies).

With EtherCAT, the costly Ethernet star topology is replaced with a simple line structure - no expensive infrastructure components are required.

- Optionally, EtherCAT can be wired in the classic way using switches, to integrate other Ethernet devices.
- Where other real-time Ethernet approaches require special connections in the controller, for EtherCAT, very cost-effective standard Ethernet cards suffice.

14.17.4.3.1 EtherCAT is Versatile

These communication connections are supported (see image):

- Master to Master
- Master to Slave
- Slave to Slave

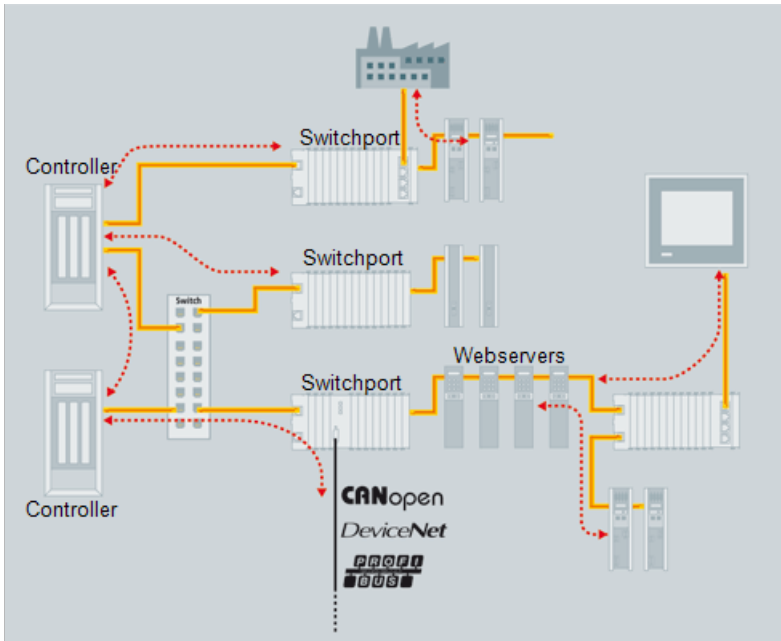

Figure 14-21: Versatile Network Architecture

14.17.4.3.2 Safety over EtherCAT is Available

- EtherCAT makes Ethernet down to the I/O level technically feasible and economically sensible.
- Outstanding features of this network include:
 - Full Ethernet compatibility.
 - Internet technologies (even in simple devices).
 - Maximum utilization of the large bandwidth offered by Ethernet.
 - Outstanding real-time characteristics at low costs.

14.17.4.3.3 Device Profiles

Device profiles describe the application parameters and the functional behavior of the devices, including the device class-specific state machines.

- For many device classes, fieldbus technology already offers reliable device profiles, such as for I/O devices or drives.
 - Users are familiar with these profiles and the associated parameters and tools.
- No EtherCAT-specific device profiles have been developed for these device classes.
 - Simple interfaces for existing device profiles are offered.
 - This greatly assists users and device manufacturers alike during the change from existing fieldbuses to EtherCAT.

14.17.4.3.4.1 CANopen over EtherCAT (CoE)

CANopen device and application profiles are available for a wide range of device classes and applications.

Devices include I/O components, drives, encoders, proportional valves and hydraulic controllers to application profiles for plastic or textile machinery.

- EtherCAT can provide the same communication mechanisms as the familiar CANopen mechanisms: object dictionary, PDO (process data objects) and SDO (service data objects), and even the network management is comparable.
- EtherCAT can be implemented with minimum effort on devices equipped with CANopen.
- Large parts of the CANopen firmware can be re-used.
- Objects can optionally be expanded in order to account for the larger bandwidth offered by EtherCAT.

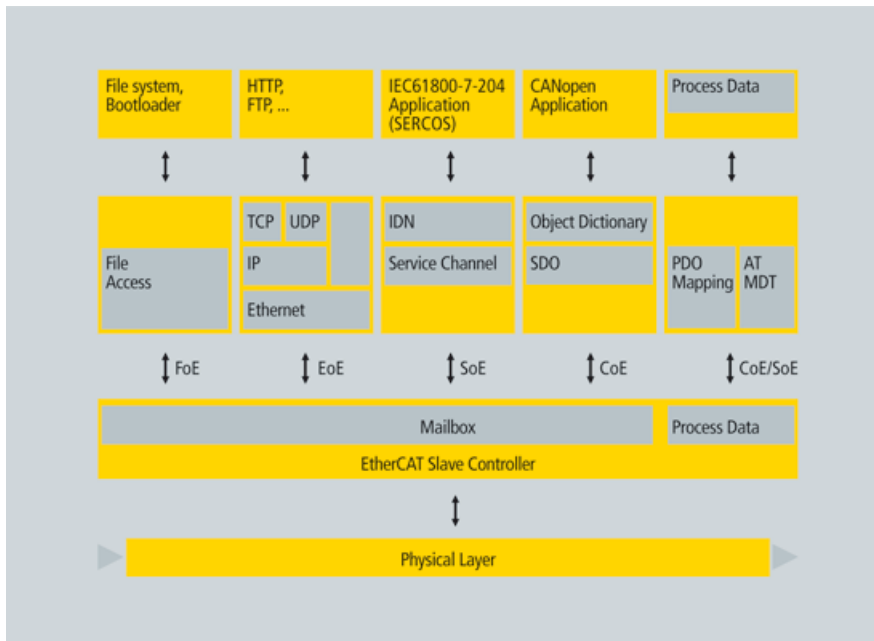

Figure 14-22: Several Device Profiles and Protocols can Coexist

14.17.4.3.5 Distributed Clock (Synchronization)

A distributed clock is an EtherCAT feature that allows synchronization, with a reference clock, of all EtherCAT slaves and the master. This solves problems related to clock-shifting between the master and the devices.

This mechanism leads to very low jitter of significantly less than 1 μ s. Even if the communication cycle jitters, it is still compliant with the IEEE 1588 Precision Time Protocol standard.

EtherCAT does not require special hardware in the master device and can be implemented in software on any standard Ethernet MAC, even without a dedicated communication coprocessor.

- The typical process of establishing a distributed clock is initiated by the master by sending a broadcast to all slaves at a specific address.
 - On reception of this message, all slaves latch the value of their internal clock twice, once when the message is received and once when it returns (remember EtherCAT has a ring topology).
 - The master then reads all latched values and calculates the delay for each slave.
- This process can be repeated as many times as required to reduce jitter and to average out values.
- Total delays are calculated for each slave depending on their position in the slave-ring and are uploaded to an offset register.
- Finally the master issues a broadcast read-write on the system clock, which makes the first slave the reference clock and forcing all other slaves to set their internal clock appropriately with the now known offset.

To keep the clocks synchronized after initialization, the master or slave must regularly send out the broadcast again to counter any effects of speed difference between the internal clocks of each slave.

- Each slave has to adjust the speed of their internal clock or implement an internal correction mechanism whenever they have to adjust.
- The system clock is specified as a 32-bit counter with a base unit of 1 ns starting at January 1st 2000, 0:00.

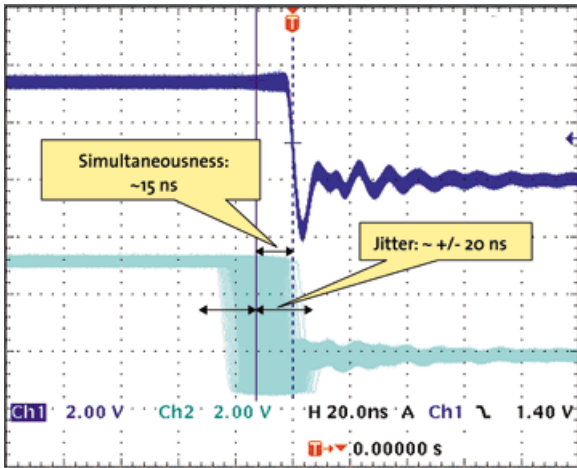

Figure 14-23: Synchronicity and Simultaneousness

Scope view of two distributed devices with 300 nodes and 120 m of cable between them.

14.17.4.3.6 File Access over EtherCAT (FoE)

This very simple protocol, similar to TFTP, enables access to any data structure in the device.

Standardized firmware upload to devices is possible, regardless of whether or not they support TCP/IP.

14.17.4.3.7 Gateways

Gateway devices are available for the integration of existing fieldbus components (e.g., CANopen, DeviceNet) into EtherCAT networks.

- Other Ethernet protocols can be used in conjunction with EtherCAT.
 - The Ethernet frames are tunneled via the EtherCAT protocol, which is the standard approach for Internet applications.
- The EtherCAT network is fully transparent for the Ethernet device.
 - The real-time characteristics are not impaired since the master dictates exactly when the tunneled transfers are to occur and how much of the 100Mb/s media the tunneled protocols can use.
- Therefore, all Internet technologies can also be used in the EtherCAT environment.

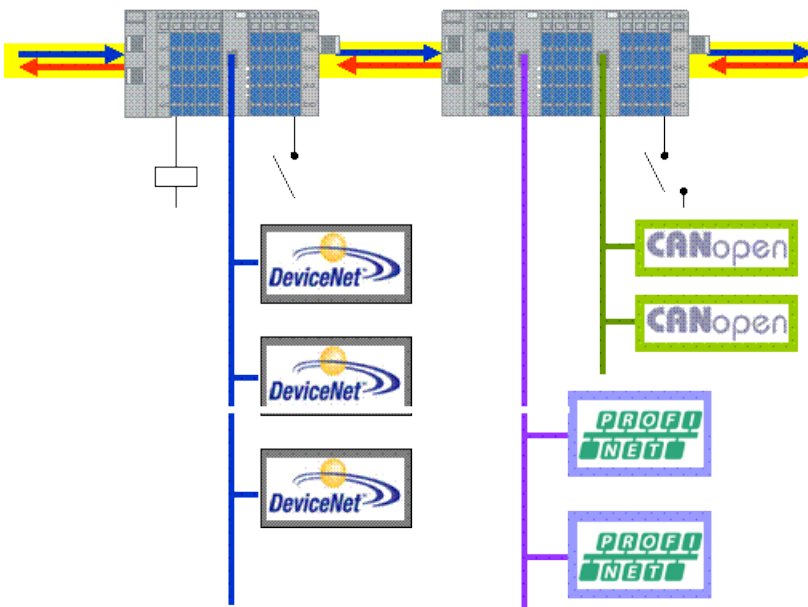

Figure 14-24: Fieldbus Gateway

14.17.4.3.8 Performance

Short cycle times can be achieved because the host microprocessors in the slave devices are not involved in the processing of the Ethernet packets to transfer the process images.

- All process data communication is handled by the slave controller hardware.
- Combined with these features, this makes EtherCAT a high-performance distributed I/O system:
 - Process data exchange with 1000 distributed digital I/O takes about 30 μs , which is typical for a transfer of 125 byte over 100Mb/s Ethernet. Data for and from 100 servo axes can be updated with up to 10 kHz.
- Typical network update rates are 1-30 kHz, but EtherCAT can be used with slower cycle times, too, if the DMA load is too high on your PC.

Process Data	Update Time
256 distributed digital I/O	11 μs = 0,01 ms
1000 distributed digital I/O	30 μs
200 analog I/O (16 bit)	50 μs \leftrightarrow 20 kHz
100 Servo Axis, with 8 Bytes input and output data each	100 μs
1 Fieldbus Master-Gateway (1486 Bytes Input and 1486 Bytes Output Data)	150 μs

Figure 14-25: EtherCAT Performance Overview

The communication with 100 servo axes is also extremely fast: every 100 μs , all axes are provided with command values and control data and report their actual position and status.

- The "Distributed Clock (Synchronization)" (\rightarrow p. 789) technique enables the axes to be synchronized with a deviation of significantly less than 1 microsecond.
- Even at this pace, there is more than sufficient bandwidth for asynchronous communications such as TCP/IP, parameter download or diagnostic data upload.

14.17.4.3.9 Protocol

The EtherCAT protocol is optimized for process data and is transported directly within the standard IEEE 802.3 Ethernet frame using Ethertype 0x88a4.

- It can consist of several sub-datagrams, each serving a particular memory area of the logical process images that can be a maximum of four gigabytes in size.
- The data sequence is independent of the physical order of the nodes in the network and addressing can be in any order.
- Broadcast, multicast, and communication between slaves is possible and must be done by the master device.
- If IP routing is required, the EtherCAT protocol can be inserted into UDP/IP datagrams.
 - This enables any control with Ethernet protocol stack to address EtherCAT systems.

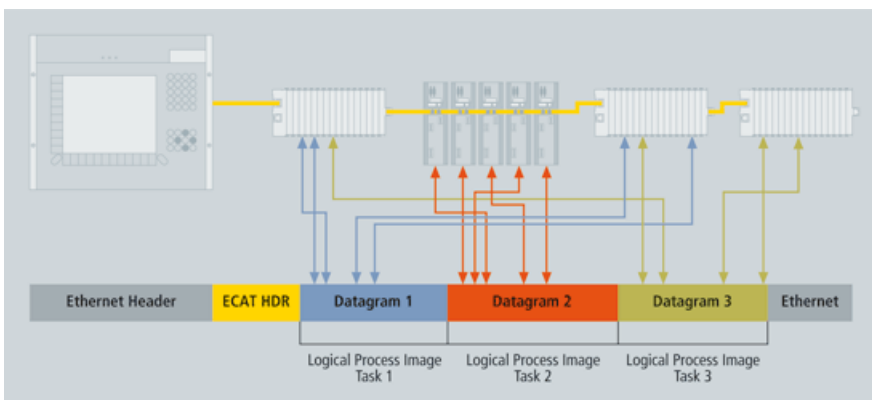

Figure 14-26: Process Data is Inserted in Telegrams

- KAS supports "CANopen over EtherCAT (CoE)" (→ p. 788).
 - It enables the advantages of EtherCAT in terms of transfer characteristics to be combined with proven, profile-specific drive functions.
- KAS uses "File Access over EtherCAT (FoE)" (→ p. 790) protocols to provide options for efficiently exchanging firmware via the bus.
 - See Figure: **"Several Device Profiles and Protocols can Coexist"** for more information.

14.17.4.3.10 Safety over EtherCAT

The protocol enhancement called Safety over EtherCAT (FcSoE) enables safety-related communication and control communication on the same network.

- The safety protocol is based on the application layer of EtherCAT, with no influence on the lower layers.
- It is certified according to IEC 61508 and meets the requirements of Safety Integrity Level (SIL) 3.

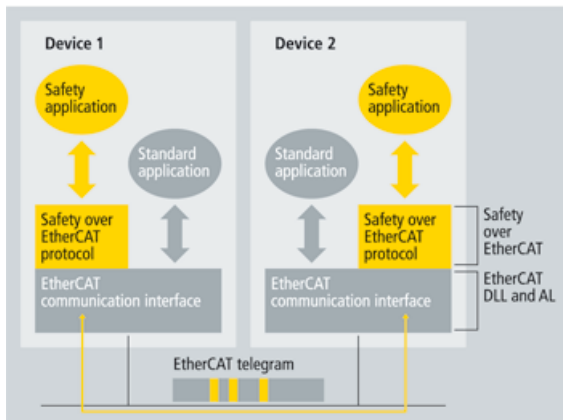
**Figure 14-27:** Safety over EtherCAT Software Architecture

14.17.4.3.11 Topology

Using full-duplex Ethernet physical layers, EtherCAT slave controllers close an open port automatically and return the Ethernet frame if no downstream device is detected.

- Slave devices can have several ports.
- Using these features, EtherCAT can support almost any physical topology (e.g., line, tree, or star).
 - The bus or line structure known from the fieldbuses is then available for Ethernet.

The combination of line and branches or stubs is also possible.

- Any EtherCAT device with three or more ports can act as a junction; no additional switches are required.
- The classic switch-based Ethernet star topology can be used either with switches configured to forward traffic directly between ports, or with special slave devices.
 - The switches are then located between the network master and the slave devices.

The special slave device assembly (i.e., standard slave devices don't have a MAC address) attached to one switch port together forms an EtherCATsegment. This is either addressed via its MAC address or via port-based VLANs.

- Since the 100BASE-TX Ethernet physical layer is used, the distance between any two nodes can be up to a maximum of 100 m (300 ft).
- Up to 65535 devices can be connected per segment.
- If an EtherCAT network is wired in ring configuration (requiring two ports on the master device), it can provide cable redundancy.

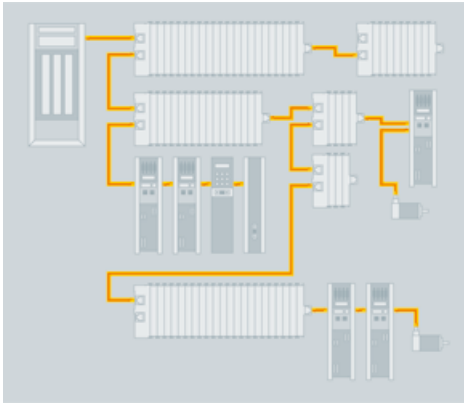

Figure 14-28: Flexible Topology: Line, Tree, or Star

- KAS controllers support line, tree, and star topologies.
- Ring topologies and cable redundancy is not supported because the KAS controllers have a single EtherCAT port.

14.17.4.4 EtherCAT Implementation

EtherCAT was developed with very low cost devices in mind, like I/O terminals, sensors, and embedded controllers.

- EtherCAT only uses standard Ethernet frames according to IEEE 802.3.
 - These frames are sent by the master device, and the slave devices extract and/or insert data on the fly.
 - EtherCAT uses standard Ethernet MACs, where they really make sense: in the master device.
- EtherCAT slave controllers are used where such dedicated chips really make sense: in the slave device.
 - They handle the process data protocol in hardware and provide maximum real-time performance regardless of the local processing power or software quality.

14.17.4.4.1 Master Configuration

EtherCAT communicates a maximum of 1486 bytes of distributed process data with just one Ethernet frame.

- Unlike other solutions where the master device in each network cycle has to process, send, and receive frames for each node, EtherCAT systems typically only need one or two frames per cycle for the entire communication with all nodes.
 - EtherCAT masters do not require a dedicated communication processor.
 - The master functionality puts hardly any load on the host CPU, which can handle this task easily while processing the application program.
- EtherCAT can be implemented without special or expensive active plug-in cards, just by using a passive NIC card or the on-board Ethernet MAC.
 - Implementation of an EtherCAT master is very easy, particularly for small and medium-sized control systems and for clearly defined applications.

Example

- A PLC with a single process image: if it does not exceed the 1486 bytes, cyclic sending of a single Ethernet frame with the cycle time of the PLC is sufficient.
 - See Figure: "**Master-Implementation with One Process Image**" for more information.
 - Because the header does not change at run-time, the only thing required is that a constant header be added to the process image and that the result be transferred to the Ethernet controller.
- The process image is already sorted, since with EtherCAT mapping does not occur in the master, but in the slaves - the peripheral devices insert their data at the respective points in the passing frame.
 - This further unburdens the host CPU.
- It was found that an EtherCAT master entirely implemented in software on the host CPU uses less of its processing power than much slower fieldbus systems implemented with active plug-in cards.
 - Servicing the DPRAM of the active card alone puts more load on the host.

System configuration tools provide the network and device parameters (including the corresponding boot-up sequence) in a standardized XML format.

See "Configure EtherCAT Motion Bus" (→ p. 138) for more information.

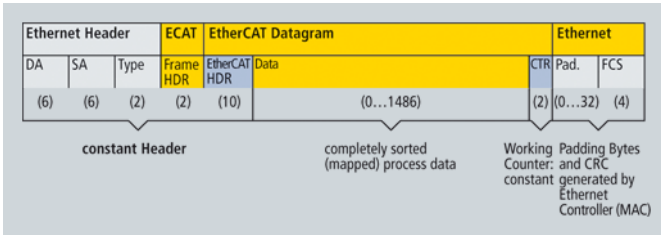

Figure 14-29: Master-Implementation with One Process Image

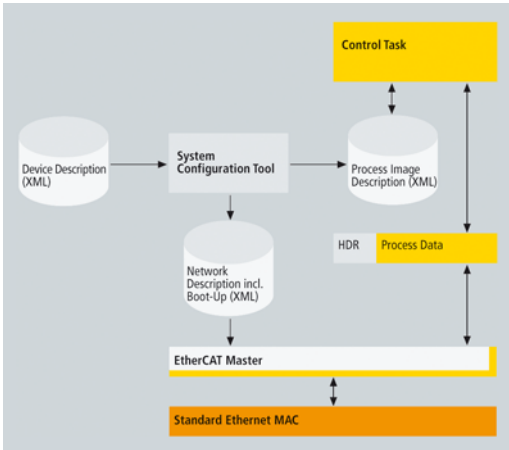

Figure 14-30: Structure of EtherCAT Master Implementation

14.17.4.4.2.1 ESI and ENI Files

The EtherCAT master uses the information from the ENI file to initialize and configure the EtherCAT network.

- The ESI files are provided by the vendor for each device.
 - They contain information about the device functionality and its settings.
- The ESI files are used by the KAS-IDE to generate the ENI file.
- The KAS controller's EtherCAT master uses the ENI file for network initialization and configuration.

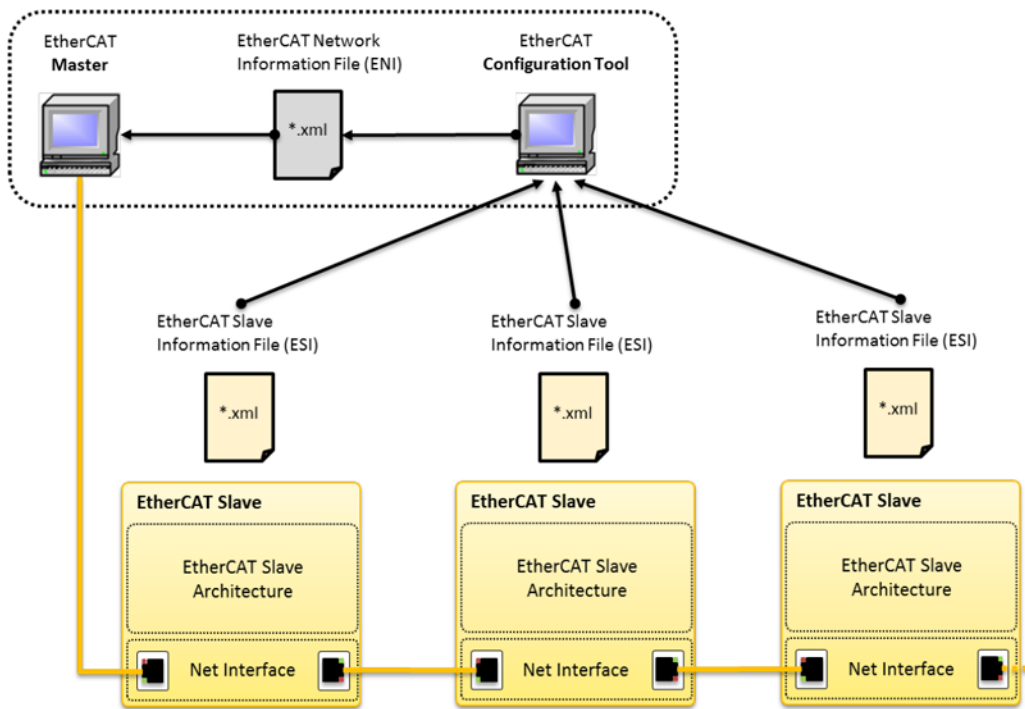

Figure 14-31: EtherCAT Network Architecture ¹

ENI File A network configuration file in XML format.

- The ENI file describes the network topology, the initialization commands for each device, and commands which have to be sent cyclically.
 - The ENI file is provided to the master, which sends commands according to this file.
- The KAS-IDE creates the ENI file after a network discovery, which can be exported or imported.
 - A scan and compile should be redone, if the network changes, in order to regenerate the ENI file.

ESI File A device description in XML format.

- This is a fixed file provided by the supplier of a given EtherCAT device.
 - The ESI file contains information about the device's functionality and settings.
- EtherCAT device vendors must provide an ESI file, which is used by the KAS-IDE to compile the network information (e.g., process data structures, initialization commands) and create the ENI file.

NOTE

KAS uses ENI schema version 1.3 (May 20, 2009).
See the ETG.2100 specification at www.ethercat.org for more information.

14.17.4.4.3 Slave Configuration

A cost-effective EtherCAT slave controller (ESC) is used in the slave devices.

- With EtherCAT, the slave does not need a microcontroller.
 - Simple devices with an I/O interface can be implemented only with the ESC and the RJ45 connector.

¹Image courtesy of EtherCAT.org, http://www.ethercat.org/pdf/english/etg2200_v2i0i1_slaveimplementationguide.pdf

- The process data interface (PDI) to the slave application is a 32-bit I/O interface.
 - This slave without configurable parameters needs no software or mailbox protocol.
- The EtherCAT State Machine is handled in the ESC.
 - The boot-up information for the ESC comes out of the EEPROM that also supports the identity information of the slave.
 - More complex slaves that are configurable have a host CPU on board.
 - This CPU is connected to the ESC with an 8-bit or 16-bit parallel interface or via a serial connection.

14.17.4.4.1 EtherCAT Slave Controller

The slave controllers typically feature an internal DPRAM and offer a range of interfaces for accessing this application memory:

- The SPI (serial peripheral interface bus) is intended for devices with small process data quantity (e.g., analog I/O modules, sensors, encoders or simple drives).
- The parallel 8/16-bit microcontroller interface corresponds to conventional interfaces for fieldbus controllers with DPRAM interface.
 - It is particularly suitable for more complex devices with larger data volume.
- The 32-bit parallel I/O interface is suitable for the connection of up to 32 digital inputs/outputs, but also for simple sensors or actuators operating with 32 data bits.
 - Such devices do not need a host CPU at all (see image Figure: "**Slave Hardware: FPGA with direct I/O**").

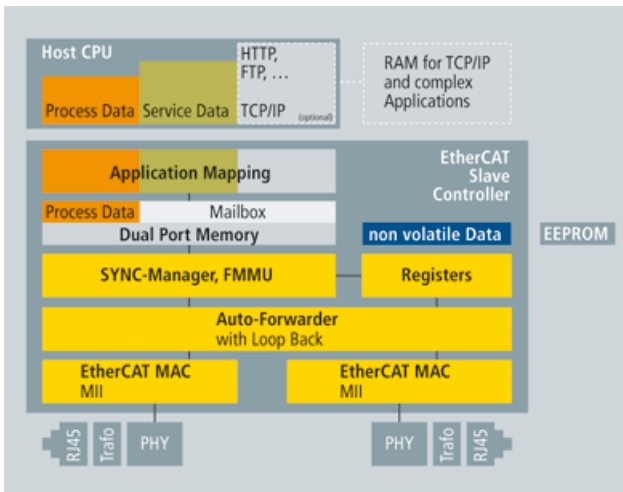

Figure 14-32: Slave Hardware: FPGA with Host CPU

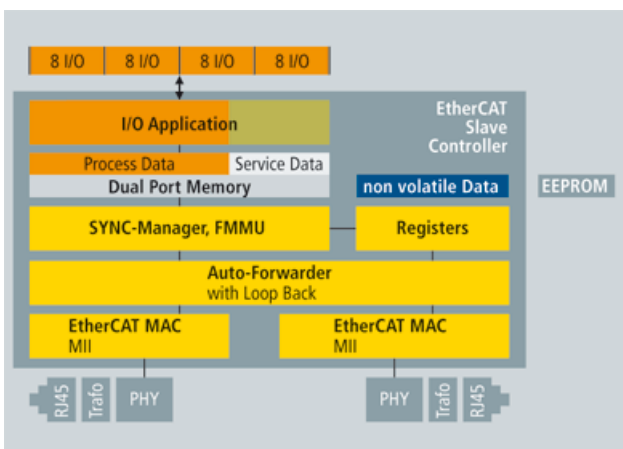

Figure 14-33: Slave Hardware: FPGA with direct I/O

14.17.4.4.5 EtherCAT State Machine

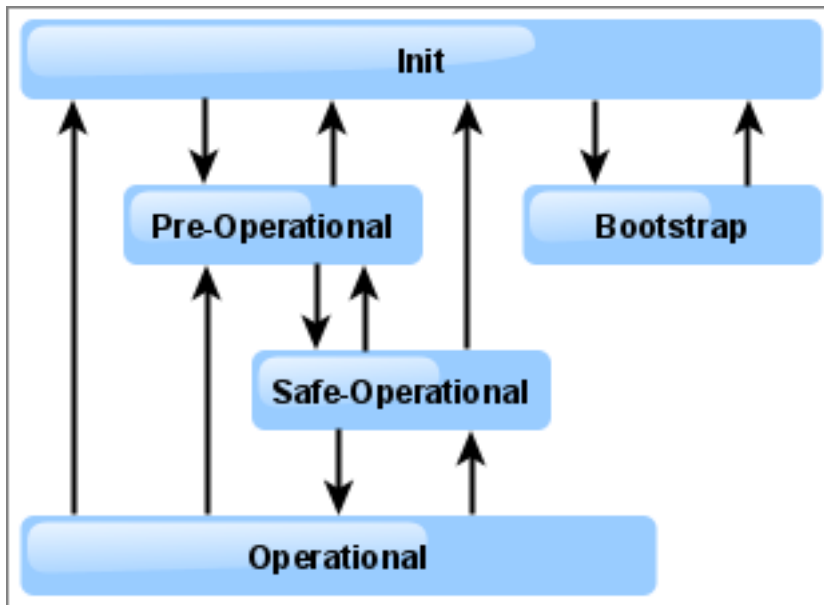

Figure 14-34: EtherCAT State Machine

Where the transitions are from:

- **Init to Pre-Operational (Pre-Op)**: Master configures the Sync Manager channels for Mailbox communication.
- **Pre-Op to Safe-Operational (Safe-Op)**: Master configures parameter using the Mailbox.
- **Safe-Op to Operational (Op)**: Master sends valid Outputs.

14.17.4.4.6.1 Different States

State	Description
Bootstrap	<ul style="list-style-type: none"> • Recommended if firmware updates are necessary. • No Process Data communication. • Communication via Mailbox on Application Layer. • Only the "File Access over EtherCAT (FoE)" (→ p. 790) protocol is available.
Init	<ul style="list-style-type: none"> • No communication on the Application Layer. • Master has access to the DL-Information registers.
Operational (Op)	Inputs and Outputs are valid.
Pre-Operational (Pre-Op)	<ul style="list-style-type: none"> • Mailbox communication on the Application Layer. • No Process Data communication.
Safe-Operational (Safe-Op)	<ul style="list-style-type: none"> • Mailbox communication on the Application Layer. • Process Data communication. • Only Inputs are evaluated (Outputs in Safe state).

14.17.4.4.7 PDOs for AKD, AKD2G, AKD-N, S300, or S700

The KAS Motion Engine interacts with the AKD, AKD2G, AKD-N, S300, or S700 drives through CANopen objects in the selected PDOs.

- Some of the ML and MC function blocks require specific CANopen objects in the PDOs.
- Defaults:
 - AKD, AKD2G, and AKD-N PDOs include all of the CANopen objects needed by the motion engine and function blocks.
 - S300 and S700 PDOs include only the minimal CANopen objects required by the KAS motion engine.

14.17.4.4.8.1 PDO Types

- **RxPDO** — "From Controller to Drive (RxPDO)" (→ p. 798)
 - Drive and Objects
 - "RxPDO - AKD Drive CANopen Objects" (→ p. 800)
 - "RxPDO - AKD2G Drive CANopen Objects" (→ p. 801)
 - "RxPDO - AKD-N Drive CANopen Objects" (→ p. 803)
 - "RxPDO - S300 and S700 Drive CANopen Objects" (→ p. 804)
- **TxPDO** — "From Drive to Controller (TxPDO)" (→ p. 804)
 - Drives and Objects
 - "TxPDO - AKD Drive CANopen Objects" (→ p. 807)
 - "TxPDO - AKD2G Drive CANopen Objects" (→ p. 805)
 - "TxPDO - AKD-N Drive CANopen Objects" (→ p. 810)
 - "TxPDO - S300 and S700 Drive CANopen Objects" (→ p. 811)

14.17.4.4.9.2 Examples

These are examples where the PDO object is passed as an argument in the function block.

14.17.5 Example 1

```
MLSmpConECAT( PipeNetwork.SMP1, 1001, 16#2050, 0 );
```

Where:

- PipeNetwork.SMP1 is a Sampler block ID.
- 1001 is the EtherCAT address for the first device.
- 16#2050 (0x2050) is the object index and 0 is the subindex for the AKD's "Position actual value 2" object.

14.17.6 Example 2

```
MLCNVConnectEx(PipeNetwork.CNV1, PipeNetwork.AXIS1, EC_ADDITIVE_TORQUE_VALUE, 0 ) ;
```

The argument is a constant based on the object index.

14.17.7 Example 3

```
MLSmpConPNAxis(PipeNetwork.SMP1, PipeNetwork.AXIS1, ML_SECOND_FEEDBACK_POSITION) ;
```

Where:

ML_SECOND_FEEDBACK_POSITION specifies the secondary actual position from the Pipe Network Axis.

NOTE

The ML_SECOND_FEEDBACK_POSITION constant has been deprecated and only AKD devices supported it. It is deprecated because the AKD2G supports more than one secondary feedback.

14.17.7.0.1.1 From Controller to Drive (RxPDO)

These Controller to Drive objects are available in the default PDO.

- "RxPDO - AKD Drive CANopen Objects" (→ p. 800)
- "RxPDO - AKD2G Drive CANopen Objects" (→ p. 801)
- "RxPDO - AKD-N Drive CANopen Objects" (→ p. 803)
- "RxPDO - S300 and S700 Drive CANopen Objects" (→ p. 804)

15 RxPDO - AKD Drive CANopen Objects

This table identifies:

- The CANopen objects required by the motion engine and function blocks.
- Whether the objects are available in the default PDO.
- Their corresponding drive parameter.

ⓘ IMPORTANT

Review the table to verify the objects needed by the features the application uses are included in the PDO selection.

RxPDO - AKD Drive CANopen Objects					
Index - subindex	Object Name	Required	Associated ML FB	Associated MC FB	Associated Drive Parameter
0x20A4 - 0 or 0x2802 - 0	Latch control word	No	<ul style="list-style-type: none"> • MLAxisCfgFastIn • MLAxisTimeStampr • All Trigger MLTrig FB 	<ul style="list-style-type: none"> • MC_AbortTrigger • MC_TouchProbe 	<ul style="list-style-type: none"> • CAP0.EN • CAP1.EN • CAP0.MODE • CAP1.MODE
0x3470 - 3	AOUT.VALUE Used by Onboard I/O mappings	No	N/A	N/A	AOUT.VALUEU
0x6040 - 0	CANopen Control Word	Yes		<ul style="list-style-type: none"> • MC_ClearFaults • MC_Power 	
0x60B2 - 0 or 0x60F6 - 1	Additive torque value Torque Feed Forward	No	MLAxisAddTq	N/A	IL.BUSFF
0x60C1 - 1 or 0x6062 - 0	Position demand value	Yes	<ul style="list-style-type: none"> • Related to the Axis MLAxisCmdPos pipe block positions. • See "Associated Data on Positions" (→ p. 733) for more information. 	<ul style="list-style-type: none"> • MC_ReadParam • ID-1 in "Non-Boolean Parameters" (→ p. 756) 	PL.CMD
0x60FE - 1	Digital outputs Used by Onboard I/O mappings	No	N/A	N/A	DOUT.STATES

16 RxPDO - AKD2G Drive CANopen Objects

This table identifies:

- The CANopen objects required by the motion engine and function blocks.
- Whether the objects are available in the default PDO.
- Their corresponding drive parameter.

ⓘ IMPORTANT

Review the table to verify the objects needed by the features the application uses are included in the PDO selection.

NOTE

Axis 1 objects begin with 0x60.
Axis 2 objects begin with 0x68.

RxPDO - AKD2G Drive CANopen Objects

Index - subindex	Object Name	Required	Associated ML FB	Associated MC FB	Associated Drive Parameter
0x3601:1	Physical Outputs Used by Onboard I/O mappings	No	N/A	N/A	DOUT.STATES
0x3800:2	AOUT1.Fieldbus Value Used by Onboard I/O mappings	No	N/A	N/A	AOUT.VALUE
0x3801:2	AOUT2.Fieldbus Value Used by Onboard I/O mappings	No	N/A	N/A	AOUT.VALUE
0x6040:0 or 0x6840:0	CANopen Control Word	Yes	Needed for motion engine axis to work properly.	<ul style="list-style-type: none"> • Needed for motion engine axis to work properly: <ul style="list-style-type: none"> • MC_ClearFaults • MC_Power 	

RxPDO - AKD2G Drive CANopen Objects					
Index - subindex	Object Name	Required	Associated ML FB	Associated MC FB	Associated Drive Parameter
0x6070A:0 or 0x6870:0	Target Position Axis 1 / 2	Yes	<ul style="list-style-type: none"> • Needed for motion engine axis to work properly: <ul style="list-style-type: none"> • Related to the Axis MLAxisCmdPos pipe block positions. • See "Associated Data on Positions" (→ p. 733) for more information. 	<ul style="list-style-type: none"> • Needed for motion engine axis to work properly: <ul style="list-style-type: none"> • MC_ReadParam • ID-1 in "Non-Boolean Parameters" (→ p. 756) 	
0x60B8:0 or 0x68B8:0	Touchprobe function Axis 1 / 2	No	<ul style="list-style-type: none"> • MLAxisCfgFastIn • MLAxisTimeStamp • All Trigger MLTrig FB 	<ul style="list-style-type: none"> • MC_AbortTrigger • MC_MachRegist • MC_MarkRegist • MC_Reference • MC_StopRegist • MC_TouchProbe 	

17 RxPDO - AKD-N Drive CANopen Objects

This table identifies:

- The CANopen objects required by the motion engine and function blocks.
- Whether the objects are available in the default PDO.
- Their corresponding drive parameter.

ⓘ IMPORTANT

Review the table to verify the objects needed by the features the application uses are included in the PDO selection.

RxPDO - AKD-N Drive CANopen Objects					
Index - subindex	Object Name	Required	Associated ML FB	Associated MC FB	Associated Drive Parameter
0x20A4 - 0 or 0x2802 - 0	Latch control word	No	<ul style="list-style-type: none"> • MLAxisCfgFastIn • MLAxisTimeStamp • All Trigger MLTrig FB 	<ul style="list-style-type: none"> • MC_AbortTrigger • MC_TouchProbe 	<ul style="list-style-type: none"> • CAP0.EN • CAP1.EN • CAP0.MODE • CAP1.MODE
0x6040 - 0	CANopen Control Word	Yes		<ul style="list-style-type: none"> • MC_ClearFaults • MC_Power 	
0x60B2 - 0 or 0x60F6 - 1	Additive torque value Torque Feed Forward	No	MLAxisAddTq	N/A	IL.BUSFF
0x60C1 - 1 or 0x6062 - 0	Position demand value	Yes	<ul style="list-style-type: none"> • Related to the Axis MLAxisCmdPos pipe block positions. • See "Associated Data on Positions" (→ p. 733) for more information. 	<ul style="list-style-type: none"> • MC_ReadParam • ID-1 in "Non-Boolean Parameters" (→ p. 756) 	PL.CMD
0x60FE - 1	Digital outputs Used by Onboard I/O mappings	No	N/A	N/A	DOUT.STATES

18 RxPDO - S300 and S700 Drive CANopen Objects

This table identifies:

- The CANopen objects required by the motion engine and function blocks.
- Whether the objects are available in the default PDO.
- Their corresponding drive parameter.

ⓘ IMPORTANT

Review the table to verify the objects needed by the features the application uses are included in the PDO selection.

RxPDO - S300 and S700 Drive CANopen Objects					
Index - subindex	Object Name	Required	Associated ML FB	Associated MC FB	Associated Drive Parameter
0x20A4 - 0 or 0x2802 - 0	Latch control word	No	<ul style="list-style-type: none"> • MLAxisCfgFastIn • MLAxisTimeStamp • All Trigger MLTrig FB 	<ul style="list-style-type: none"> • MC_AbortTrigger • MC_TouchProbe 	<ul style="list-style-type: none"> • CAP0.EN • CAP1.EN • CAP0.MODE • CAP1.MODE
0x6040 - 0	CANopen Control Word	Yes		<ul style="list-style-type: none"> • MC_ClearFaults • MC_Power 	
0x60B2 - 0 or 0x60F6 - 1	Additive torque value Torque Feed Forward	No	MLAxisAddTq	N/A	IL.BUSFF
0x60C1 - 1 or 0x6062 - 0	Position demand value	Yes	<ul style="list-style-type: none"> • Related to the Axis MLAxisCmdPos pipe block positions. • See "Associated Data on Positions" (→ p. 733) for more information. 	<ul style="list-style-type: none"> • MC_ReadParam • ID-1 in "Non-Boolean Parameters" (→ p. 756) 	PL.CMD

18.0.0.0.1.1 From Drive to Controller (TxPDO)

These Drive to Controller objects are available in the default PDO.

- "TxPDO - AKD Drive CANopen Objects" (→ p. 807)
- "TxPDO - AKD2G Drive CANopen Objects" (→ p. 805)
- "TxPDO - AKD-N Drive CANopen Objects" (→ p. 810)
- "TxPDO - S300 and S700 Drive CANopen Objects" (→ p. 811)

19 TxPDO - AKD2G Drive CANopen Objects

This table identifies:

- The CANopen objects required by the motion engine and function blocks.
- Whether the objects are available in the default PDO.
- Their corresponding drive parameter.

ⓘ IMPORTANT

Review the table to verify the objects needed by the features the application uses are included in the PDO selection.

NOTE

Axis 1 objects begin with 0x60.
Axis 2 objects begin with 0x68.

TxPDO - AKD2G Drive CANopen Objects

Index - subindex	Object Name	Required	Associated ML FB	Associated MC FB	Associated Drive Parameter
0x3780:1	AIN1.VALUE	No	N/A	N/A	
0x3781:1	AIN2.VALUE	No	N/A	N/A	
0x6041:0 or 0x6841:0	Status word Axis 1 / 2	Yes	Needed for the servo axis mapped to the drive to work properly.	Needed for the servo axis mapped to the drive to work properly.	
0x6064:0 or 0x6864:0	Position actual value Axis 1 / 2	Yes	Needed for the servo axis mapped to the drive to work properly.	Needed for the servo axis mapped to the drive to work properly.	
0x6077:0 or 0x6877:0	Torque actual value Axis 1 / 2	No	MLAxisReadTq	MC_ReadParam	
0x60B9:0 or 0x68B9:0	Touch Probe Status Axis 1 / 2	No	<ul style="list-style-type: none"> • MLAxisCfgFastIn • MLAxisTimeStamp • All Trigger MLTrig FB 	<ul style="list-style-type: none"> • MC_AbortTrigger • MC_MachRegist • MC_MarkRegist • MC_Reference • MC_StopRegist • MC_TouchProbe 	

TxPDO - AKD2G Drive CANopen Objects					
Index - subindex	Object Name	Required	Associated ML FB	Associated MC FB	Associated Drive Parameter
0x60D1:0 or 0x68D1:0	Touch Probe 1 Time Stamp positive value Axis 1 / 2	No	<ul style="list-style-type: none"> • MLAxisCfgFastIn • MLAxisTimeStamp • All Trigger MLTrig FB 	<ul style="list-style-type: none"> • MC_AbortTrigger • MC_MachRegist • MC_MarkRegist • MC_Reference • MC_StopRegist • MC_TouchProbe 	
0x60D4:0 or 0x68D4:0	Touch Probe 2 Time Stamp positive value Axis 1 / 2	No	<ul style="list-style-type: none"> • MLAxisCfgFastIn • MLAxisTimeStamp • All Trigger MLTrig FB 	<ul style="list-style-type: none"> • MC_AbortTrigger • MC_MachRegist • MC_MarkRegist • MC_Reference • MC_StopRegist • MC_TouchProbe 	
0x60E4:3	3rd additional Position actual value Axis 1	No	MLSmpConECAT	For a digitizing axis	
0x60E4:4	4th additional Position actual value Axis 1		MLSmpConECAT	For a digitizing axis	
0x60E4:5	5th additional Position actual value Axis 1		MLSmpConECAT	For a digitizing axis	
0x60F4:0 or 0x68F4:0	Following error Actual value: Axis 1 / 2	No	MLAxisReadFEUU	MC_ReadParam	

20 TxPDO - AKD Drive CANopen Objects

This table identifies:

- The CANopen objects required by the motion engine and function blocks.
- Whether the objects are available in the default PDO.
- Their corresponding drive parameter.

ⓘ IMPORTANT

Review the table to verify the objects needed by the features the application uses are included in the PDO selection.

TxPDO - AKD Drive CANopen Objects					
Index - subindex	Object Name	Required	Associated ML FB	Associated MC FB	Associated Drive Parameter
0x6041 - 0	CANopen Control Word	Yes	N/A	N/A	N/A
0x6063 - 0 or 0x6064 - 0	Position actual value	No	<ul style="list-style-type: none"> • MLAxisFBackPos • MLAxisReadActPos 	MC_ReadActPos	PL.FB

TxPDO - AKD Drive CANopen Objects					
Index - subindex	Object Name	Required	Associated ML FB	Associated MC FB	Associated Drive Parameter
0x2050 - 0 or 0x35C9 - 0	Position actual value 2	No	MLAxisRead2ndFB	For a Digitizing axis:	PL.FB (If DRV.CMDSOURCE = 1)
			<div style="border: 1px solid black; padding: 5px; background-color: #f0f0f0;"> <p style="text-align: center; margin: 0;">NOTE</p> <p>This FB is deprecated. The recommended method for accessing feedback 1-5 on an AKD2G, or a third-party device's position feedback, is to use the Sampler block and MLSmpConECAT.</p> </div>	<ul style="list-style-type: none"> Secondarily feedback can be read by reading the actual position of the axis which is assigned to the secondary feedback. Digitizing axes always use the second feedback for the Drive. KAS does not allow a digitizing axis on a drive which has not had a servo axis already assigned. 	
0x606C - 0	Velocity actual value	No	MLAxisReadVel	MC_ReadActVel	VL.FB
0x6077 - 0	Torque actual value	No	MLAxisReadTq	MC_ReadParam	IL.FB
0x20A5 - 0 or 0x2901 - 0	Latch status word	No	<ul style="list-style-type: none"> MLAxisCfgFastIn MLAxisTimeStamp All Trigger MLTrig FB 	<ul style="list-style-type: none"> MC_AbortTrigger MC_TouchProbe 	CAPx.STATE

TxPDO - AKD Drive CANopen Objects					
Index - subindex	Object Name	Required	Associated ML FB	Associated MC FB	Associated Drive Parameter
0x20A6-0 or 0x2902-0	Latch position	No	<ul style="list-style-type: none"> MLAxisCfgFastIn MLAxisTimeStamp All Trigger MLTrig FB 	<ul style="list-style-type: none"> MC_AbortTrigger MC_TouchProbe 	<ul style="list-style-type: none"> CAPx.T - for time CAPx.PLFB - for position
0x60FD-0	Digital inputs Used by Onboard I/O mappings	No	N/A	N/A	DIN.STATES
0x3470-4	AIN.VALUE Used by Onboard I/O mappings	No	N/A	N/A	AIN.VALUE
0x60F4	Following error	No	MLAxisReadFEUU	MC_ReadParam	PL.ERR

21 TxPDO - AKD-N Drive CANopen Objects

This table identifies:

- The CANopen objects required by the motion engine and function blocks.
- Whether the objects are available in the default PDO.
- Their corresponding drive parameter.

ⓘ IMPORTANT

Review the table to verify the objects needed by the features the application uses are included in the PDO selection.

TxPDO - AKD-N Drive CANopen Objects						
Index - subindex	Object Name	Required	Associated ML FB	Associated MC FB	Associated Drive Parameter	
0x6041 - 0	CANopen Control Word	Yes	N/A	N/A	N/A	
0x6063 - 0 or 0x6064 - 0	Position actual value	No	<ul style="list-style-type: none"> • MLAxisFBackPos • MLAxisReadActPos 	MC_ReadActPos	PL.FB	
0x606C - 0	Velocity actual value	No	MLAxisReadVel	MC_ReadActVel	VL.FB	
0x6077 - 0	Torque actual value	No	MLAxisReadTq	MC_ReadParam	IL.FB	
0x20A5 - 0 or 0x2901 - 0	Latch status word	No	<ul style="list-style-type: none"> • MLAxisCfgFastIn • MLAxisTimeStamp • All Trigger MLTrig FB 	<ul style="list-style-type: none"> • MC_AbortTrigger • MC_TouchProbe 	CAPx.STATE	
0x20A6 - 0 or 0x2902 - 0	Latch position	No	<ul style="list-style-type: none"> • MLAxisCfgFastIn • MLAxisTimeStamp • All Trigger MLTrig FB 	<ul style="list-style-type: none"> • MC_AbortTrigger • MC_TouchProbe 	<ul style="list-style-type: none"> • CAPx.T - for time • CAPx.PLFB - for position 	
0x60FD - 0	Digital inputs Used by Onboard I/O mappings	No	N/A	N/A	DIN.STATES	
0x60F4	Following error	No	MLAxisReadFEUU	MC_ReadParam	PL.ERR	

22 TxPDO - S300 and S700 Drive CANopen Objects

This table identifies:

- The CANopen objects required by the motion engine and function blocks.
- Whether the objects are available in the default PDO.
- Their corresponding drive parameter.

ⓘ IMPORTANT

Review the table to verify the objects needed by the features the application uses are included in the PDO selection.

TxPDO - S300 and S700 Drive CANopen Objects

Index - subindex	Object Name	Required	Associated ML FB	Associated MC FB	Associated Drive Parameter
0x6041 - 0	CANopen Control Word	Yes	N/A	N/A	N/A
0x6063 - 0 or 0x6064 - 0	Position actual value	No	<ul style="list-style-type: none"> • MLAxisFBackPos • MLAxisReadActPos 	MC_ReadActPos	PL.FB
0x2050 - 0 or 0x35C9 - 0	Position actual value 2	No	<p>NOTE</p> <p>This FB is deprecated. The recommended method for accessing feedback 1-5 on an AKD2G, or a third-party device's position feedback, is to use the Sampler block and MLSmpConECAT.</p>	<p>For a Digitizing axis:</p> <ul style="list-style-type: none"> • Secondary feedback can be read by reading the actual position of the axis which is assigned to the secondary feedback. • Digitizing axes always use the second feedback for the Drive. • KAS does not allow a digitizing axis on a drive which has not a servo axis already assigned. 	PL.FB (If DRV.CMDSOURCE = 1)

Index - subindex	Object Name	Required	Associated ML FB	Associated MC FB	Associated Drive Parameter
0x6077 - 0	Torque actual value	No	MLAxisReadTq	MC_ReadParam	IL.FB
0x20A5 - 0 or 0x2901 - 0	Latch status word	No	<ul style="list-style-type: none"> MLAxisCfgFastIn MLAxisTimeStamp All Trigger MLTrig FB 	<ul style="list-style-type: none"> MC_AbortTrigger MC_TouchProbe 	CAPx.STATE
0x20A6 - 0 or 0x2902 - 0	Latch position	No	<ul style="list-style-type: none"> MLAxisCfgFastIn MLAxisTimeStamp All Trigger MLTrig FB 	<ul style="list-style-type: none"> MC_AbortTrigger MC_TouchProbe 	CAPx.T - for time CAPx.PLFB - for position
0x60F4	Following error	No	MLAxisReadFEUU	MC_ReadParam	PL.ERR

22.0.0.1 CANopen

22.0.0.1.1 CANopen Status Machine

The states of the status machine are revealed by using the "CANopen Status Word" (→ p. 816).

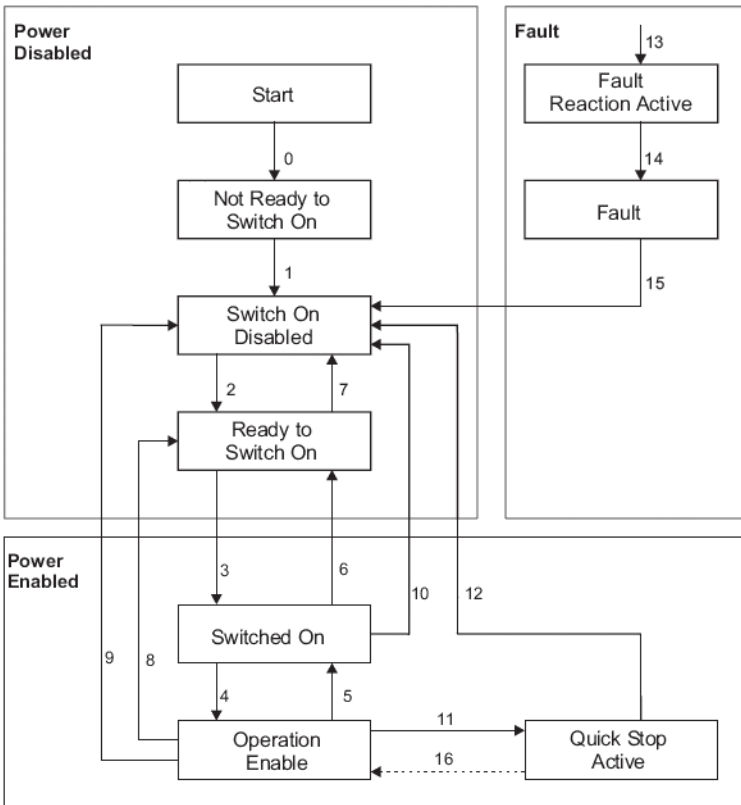

Figure 14-35: CANopen Status Machine

The start state is a pseudo-state indicating the start when the state machine is activated during the start-up sequence of the device drive's application software.

22.0.0.1.2.1 Status Description

Status	Description
Fault	<ul style="list-style-type: none"> A fault is active. The drive has been stopped and disabled.
Fault reaction active	<ul style="list-style-type: none"> A fault has occurred. The drive is stopped with the emergency stop ramp.
Not ready to switch on	<p>The drive is not ready to switch on.</p> <ul style="list-style-type: none"> The controller has not indicated readiness for service. The drive is still in the boot phase or in the fault status
Operation enabled	<p>The drive is enabled and the setpoints are transferred from the EtherCAT interface.</p> <ul style="list-style-type: none"> No fault present. Output stage is enabled. Motion functions are enabled.
Quick stop active	<ul style="list-style-type: none"> The drive has been stopped with the quick stop ramp. Output stage is enabled. Motion functions are not enabled.
Ready to switch on	<p>The drive can be enabled via the control word.</p> <ul style="list-style-type: none"> DC-link voltage can be switched on. Parameters can be transferred Motion functions cannot be performed yet.
Switch on disabled	<p>The drive cannot be enabled via the EtherCAT interface. Example: There is no connection to a power source.</p>
Switched on	<p>The drive is enabled but the setpoints are not yet transferred from the EtherCAT interface.</p> <ul style="list-style-type: none"> The drive is idle. DC-link voltage must be switched on. <ul style="list-style-type: none"> Parameters can be transferred but motion functions cannot be performed yet. Output stage is switched on (enabled). Operation Enable No fault present; output stage is enabled; motion functions are enabled.

22.0.0.1.3.2 Transitions of the Status Machine

The drive device supports these transitions and actions.

- The event initiates the transition.
- The transition is terminated after the action has been performed.

22.0.1 Transition Events and Actions

Transition	Event	Action
0	Automatic transition after power-on or reset application.	Drive device self-test and/or self initialization has to be performed.
1	Automatic transition	Communication has to be activated.

Transition	Event	Action
2	Shutdown command from control device or local signal.	None
3	Switch on command received from control device or local signal.	The high-level power has to be switched ON, if possible.
4	Enable operation command received from control device or local signal.	<ul style="list-style-type: none"> The drive function has to be enabled. All internal setpoints cleared.
5	Disable operation command received from control device or local signal.	The drive function has to be disabled.
6	Shutdown command received from control device or local signal.	The high-level power has to be switched OFF, if possible.
7	Quick stop or disable voltage command from control device or local signal.	None
8	Shutdown command from control device or local signal.	<ul style="list-style-type: none"> The drive function has to be disabled. The high-level power has to be switched OFF, if possible.
9	Disable voltage command from control device or local signal.	<ul style="list-style-type: none"> The drive function has to be disabled. The high-level power has to be switched OFF, if possible.
10	Disable voltage or quick stop command from control device or local signal.	The high-level power has to be switched OFF, if possible.
11	Quick stop command from control device or local signal.	The quick stop function has to be started.
12	Either: <ul style="list-style-type: none"> Automatic transition when the quick stop function is completed and quick stop option code is 1, 2, 3 or 4. Disable voltage command received from control device (depends on the quick stop option code). 	<ul style="list-style-type: none"> The drive function has to be disabled. The high-level power has to be switched OFF, if possible.
13	Fault signal	The configured fault reaction function has to be executed.
14	Automatic transition	<ul style="list-style-type: none"> The drive function has to be disabled. The high-level power has to be switched OFF, if possible.
15	Fault reset command from control device or local signal.	A reset of the fault condition is performed if no fault exists currently on the drive device. After leaving the Fault state, the Fault reset bit in the control word has to be cleared by the control device.

Transition	Event	Action
16	If the quick stop option code is 5, 6, 7, or 8, enable operation command from control device	The drive function has to be enabled.

22.0.1.0.1 CANopen Control Word

The status machine for the control word corresponds to the CANopen status machine.

- The control word indicates the received command controlling the state machine.
 - It is only read during **Operational** status.
- The control commands allow the manipulation of the state of a drive by setting its control word.
- Commands are built up from the logical combination of the bits in the control word and external signals (e.g., enable output stage).

22.0.1.0.2.1 Bit Assignment in Control Word

Bit	Name
0	Switch On
1	Disable Voltage
2	Quick Stop
3	Enable Operation
4	Operation-mode Specific
5	Operation-mode Specific
6	Operation-mode Specific
7	Reset Fault (only effective for faults)
8	Pause/halt
9	Reserved
10	Reserved
11	Reserved
12	Reserved
13	Manufacturer-specific
14	Manufacturer-specific
15	Manufacturer-specific

22.0.1.0.3.2 Coded Commands

Command	Bits of the Control Word					Transitions
	Bit 7	Bit 3	Bit 2	Bit 1	Bit 0	
Shutdown	0	X	1	1	0	2,6,8
Switch On	0	0	1	1	1	3
Switch On + Enable Operation	0	1	1	1	1	3 + 4 See Note.
Disable Voltage	0	X	X	0	X	7,9,10,12

Command	Bits of the Control Word					Transitions
	Bit 7	Bit 3	Bit 2	Bit 1	Bit 0	
Quick Stop	0	X	0	1	X	7,10,11
Disable Operation	0	0	1	1	1	5
Enable Operation	0	1	1	1	1	4,16
Fault Reset	Up	X	X	X	X	15

NOTE

Automatic transition to Enable operation state after executing SWITCHED ON state functionality. Bits marked by an X are irrelevant.

22.0.1.0.4 CANopen Status Word

- The status machine for the control word corresponds to the CANopen status machine.
- The status word is only updated and written by the drive in **Safe-Op** and **Operational** states.

22.0.1.0.5.1 Bit Assignment in Status Word

Bit	Name
0	Ready to switch on
1	Switched on
2	Operation Enable
3	Fault
4	Voltage Enabled
5	Quick Stop
6	Switch On Disabled
7	Warning
8	Manufacturer-specific (reserved)
9	Remote (always 1)
10	Target Reached
11	Internal Limit Active
12	Operation-mode Specific (reserved)
13	Operation-mode Specific (reserved)
14	Manufacturer-specific (reserved)
15	Manufacturer-specific (reserved)

22.0.1.0.6.2 State Coding

These are the bit combinations coding the states.

Status Word	State
MSB (15..12) (11 .. 8) (7 .. 4) (3 .. 0) LSB	
xxxx xxxx x0xx 0000	Not ready to switch on
xxxx xxxx x1xx 0000	Switch on disabled

Status Word MSB (15..12) (11 .. 8) (7 .. 4) (3 .. 0) LSB	State
xxxx xxxx x01x 0001	Ready to switch on
xxxx xxxx x01x 0011	Switched on
xxxx xxxx x01x 0111	Operation enabled
xxxx xxxx x00x 0111	Quick stop active
xxxx xxxx x0xx 1111	Fault reaction active
xxxx xxxx x0xx 1000	Fault

NOTE

Bits marked by an X are irrelevant.

22.0.2 AKD Drive

- The **servo loops** in a KAS system are located in the AKD Drive.
- The **profile generator** used for all the motion in the application is located in the controller (AKD PDMM or PCMM).

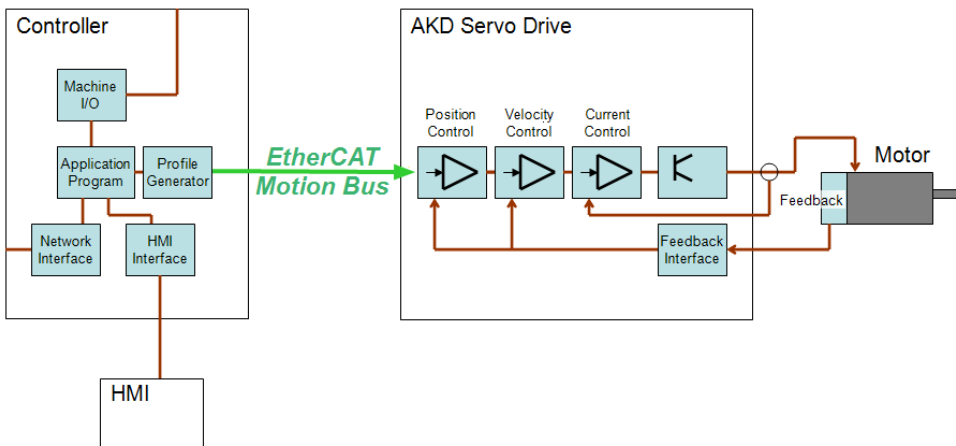

22.0.2.1 AKD Drive Configuration

22.0.2.1.1 Connection Modes

The AKD drive parameters can be configured when the KAS-IDE is connected to the controller and operating in one of these functional modes:

- "Online Configuration Mode" (→ p. 818)
- "Project Running on the Controller" (→ p. 818)

22.0.2.1.2.1 Disconnected

If the controller is not operating in one of these modes, then the AKD configurations are not accessible.

The Configuration tab indicates the AKD is Disconnected.

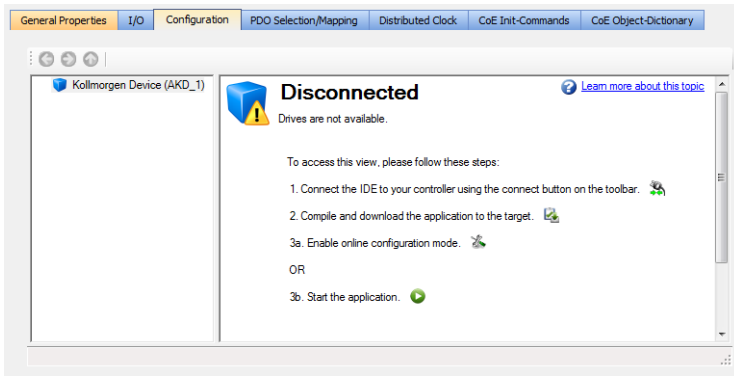

22.0.2.1.3.2 Online Configuration Mode

In Online Configuration mode, parameters are updated directly to the AKD or AKD2G through TelNet commands with EtherCAT in Pre-Operational mode.

When you modify the value of a parameter, a command is sent to the drive and the corresponding parameter is updated.

22.0.2.1.4.3 Project Running on the Controller

When a project is running on the controller, parameters are updated directly to the AKD with EtherCAT in Operational mode.

- When the value of a parameter is modified, a command is sent to the drive and the corresponding parameter is updated.
- Beware that your PLC application is running and can also read or write parameters to the AKD.

NOTE

An AKD drive cannot be deleted while it is connected.
The AKD drive leaves Online Configuration mode and starts the application if you start an application while the drive is in that mode.

ⓘ IMPORTANT

Before leaving Online Configuration mode (either by clicking the Online Configuration button or the Start button when the device is in Online Configuration mode), verify these conditions exist:

1. The drive is not enabled.
2. The service motion is not enabled.
3. Auto-tuning is not enabled.

Recommendation: Click the Disable button to force this scenario.

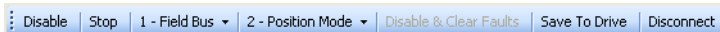

22.0.2.1.5 AKD Configuration According to EtherCAT State

The drive configuration can only take place when the EtherCAT is in the Op or Pre-Op state.

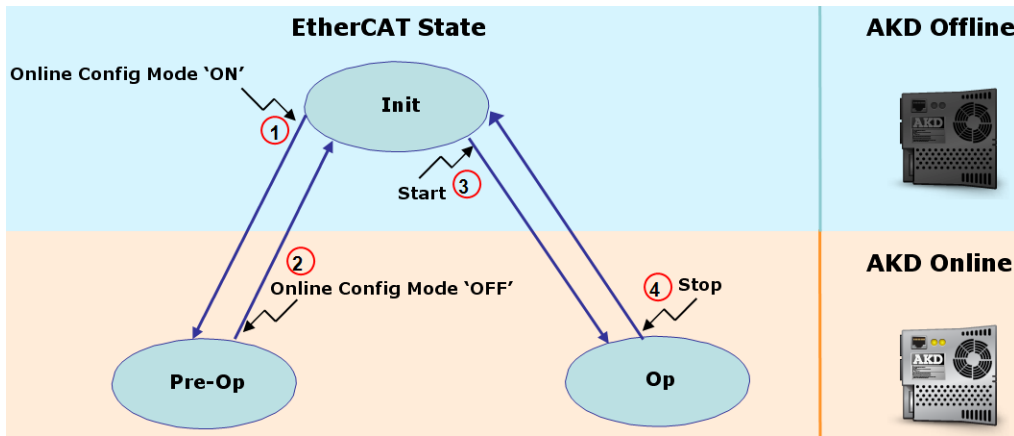

Figure 14-36: AKD Configuration According to EtherCAT State

Action	Name	Description
1	Online Configuration Mode ON	<p>Online Configuration Mode</p> <ul style="list-style-type: none"> • Sets the EtherCAT fieldbus to the Pre-Op state and allows AKD configuration. • See "Online Configuration Mode" (→ p. 255) to access this button in the KAS-IDE. • See "Configure the AKD / AKD2G Drive" (→ p. 191)) for the procedure.
2	Online Configuration Mode OFF	<ul style="list-style-type: none"> • Sets the EtherCAT fieldbus to the Init state. • Does not allow AKD configuration. • All AKD drives are disconnected from the KAS-IDE.
3	Start the Project	<ul style="list-style-type: none"> • Sets the EtherCAT fieldbus to the Operational state ¹. • See "Menus and Toolbar Overview" (→ p. 249) to access this button. • This starts the application program running and allows AKD configuration (with some restrictions for the views: Service Motion and Performance Servo Tuner). <ul style="list-style-type: none"> • See "AKD Drive" (→ p. 122).
4	Stop the Project	<ul style="list-style-type: none"> • This step stops the application from running. <ul style="list-style-type: none"> • Sets the EtherCAT fieldbus to the Init state. • Does not allow AKD configuration. • All AKD drives are disconnected from the KAS-IDE.

22.0.3 Tasking Model / Scheduling

In the KAS Runtime, both the Motion and Programmable Logic Controller (PLC) Programs are run every cycle.

- The cycle time is set when configuring the EtherCAT motion bus.
- See "EtherCAT Master Settings tab" (→ p. 327) for more information.
- The cycle time becomes effective only when the Motion Engine is started (i.e., when the PLC code initializes the Motion by calling the MLMotionIni function block) and the application runs on a controller.
 - When the Motion Engine is **not** started, the rate the PLC code runs at is approximately 10 milliseconds.

¹Depending on the number of AKD drives physically present in the EtherCAT network, the KAS-IDE can slow down when getting data.

The KAS Runtime is **not concerned** with this limitation.

22.0.3.1 Priority Between Motion and PLC

The Motion computation is always executed each cycle, and occurs before executing the PLC programs application. The "Cycle Execution On A Single-Core Controller" (→ p. 820) image shows the execution in this order:

1. Motion command, position feedback from each axis, and other elements in the EtherCAT PDO object are sent and received on the EtherCAT motion bus.
This includes servo drives and Remote I/O.
2. Motion engines are executed.
3. I/O related to the PLC program are serviced.
See "EtherCAT Processing Time" (→ p. 820) for more information.
4. PLC programs are executed.
5. NVRAM variables are saved.
See "NVRAM Processing Time" (→ p. 821) for more information.

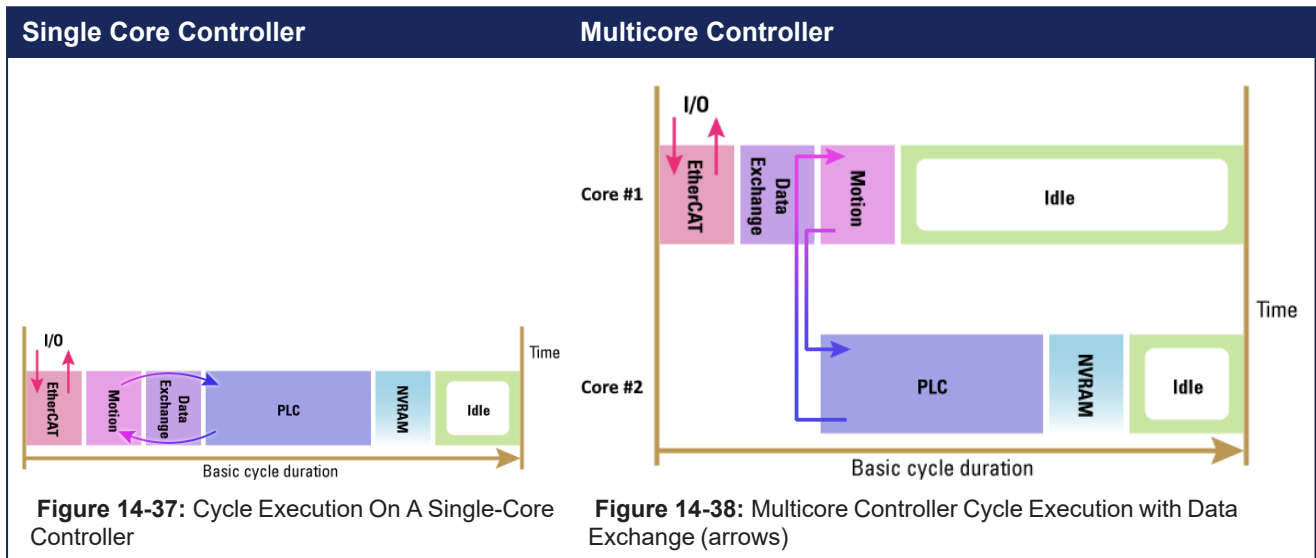

NOTE

The Motion time in the "Cycle Execution On A Single-Core Controller" (→ p. 820) image must be shorter than the basic cycle duration at each cycle. This condition is checked at each cycle and, if the cycle is overrun, Kollmorgen Automation Suite generates a fatal error and the application execution is stopped.

22.0.3.1.1 EtherCAT Processing Time

The EtherCAT frame is executed at the beginning of the cycle.

During this period, all the values related to EtherCAT are exchanged, including:

- **Inputs** are read
- **Outputs** are set

See "PDOs for AKD, AKD2G, AKD-N, S300, or S700" (→ p. 797) for more information.

- Based on the I/O mapping to PLC variables, the I/Os are updated before they are effectively used during the PLC period.
 - See "Map Input and Output to Variables" (→ p. 314) for more information.
- As a consequence, when the PLC variables set an Output, it is updated during the EtherCAT frame of the next cycle.

22.0.3.1.2.1 Variation during the EtherCAT Processing

The EtherCAT period is subject to time variation along the cycles because of these reasons:

- Some EtherCAT function blocks use asynchronous SDO communication, which is not deterministic.
 - See EtherCAT Function Blocks that Work with SDOs for more information.
- Some EtherCAT slave devices support mailbox protocols.
 - The master cyclically reads the mailbox of the EtherCAT slaves.
 - Polling of the mailbox is performed every 50 cycles
 - It is spread on several cycles depending on the number of EtherCAT slaves.

See the "FAQs" (→ p. 823) for information about SDO communication.

22.0.3.1.3 NVRAM Processing Time

Due to slow processing when saving Retain "Variables" (→ p. 704) to the NVRAM, this action is not performed each cycle.

- The save operation is performed in the background every 20 seconds.
 - The frequency increases to each 2 seconds when the application is running.
- When executed during a cycle, it occurs after the PLC period.

22.0.3.1.4 Results when a PLC Program is Overrunning the Cycle Duration

Large application can require more than one cycle to completely execute all the PLC programs.

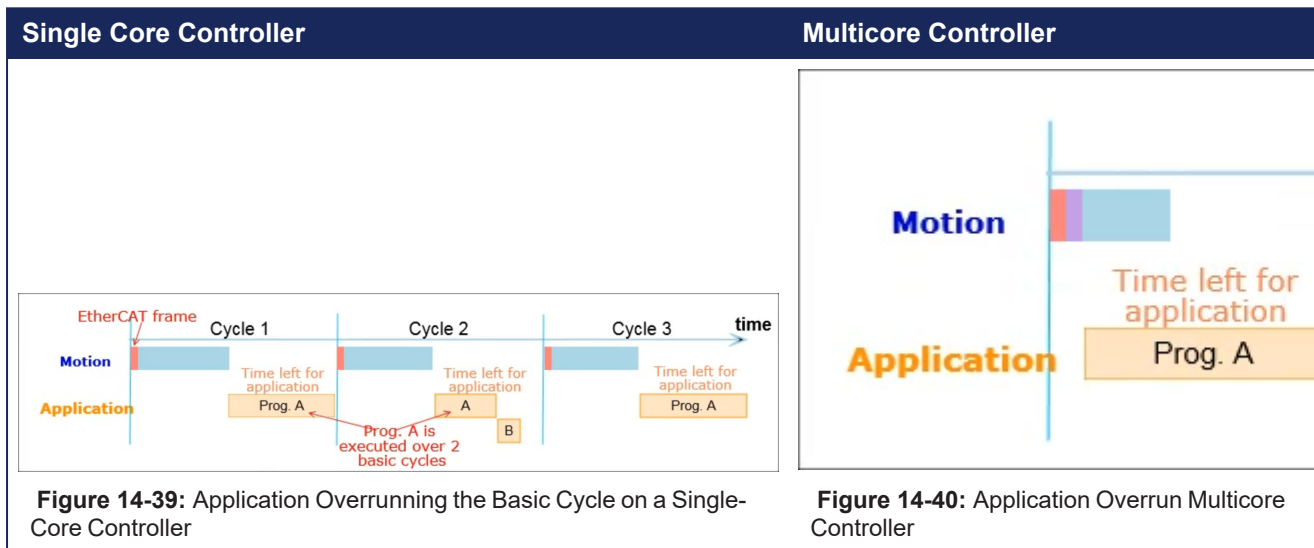

Figure 14-39: Application Overrunning the Basic Cycle on a Single-Core Controller

Figure 14-40: Application Overrun Multicore Controller

The "Application Overrunning the Basic Cycle on a Single-Core Controller" (→ p. 821) image is an example of an application with two PLC programs (A and B). It takes two cycles to execute all the code in the two programs.

- Cycle 1 executes most of Prog. A
- Cycle 2 finishes Prog. A and executes Prog. B, which is set to run with a cycle period of every other cycle.
- Cycle 3 starts executing Prog. A again

Notes

- Even if there is time left over in the cycle, execution of Prog. A does not start until the next cycle.
- An application overrun has no effect other than a short delay in the application execution. Execution of the real-time application is recovered as soon as the overload disappears.
- When running with the KAS Simulator, there is no overrunning because the cycle is extended to include all the PLC programs, right after the Motion computation.

ⓘ IMPORTANT

If Outputs are set when a program runs over several basic cycles, unexpected and potentially dangerous effects can happen.

See Also

"Change the Priority Between PLC Programs" (→ p. 822)

22.0.3.2 Change the Priority Between PLC Programs

PLC programs are assigned a priority. At times of heavy demand for processing time, the operating system serves programs with higher priority first.

For details, see:

- "Define the PLC Cycle" (→ p. 219)
- "Priority Between Motion and PLC" (→ p. 820)

23 Troubleshooting

These topics may prove useful in troubleshooting:

- "FAQs" (→ p. 823)
- "Compiler Errors" (→ p. 834)
- "Compiler Warnings" (→ p. 838)
- "Connect Remotely" (→ p. 840)
- "CPU Load Reduction Techniques" (→ p. 841)
- "Error Management" (→ p. 551) - this topic provides a programmatic procedure for when a non-fatal error occurs in the machine and motion needs to be halted quickly.
- "EtherCAT Coupler Error Handling And Diagnosis" (→ p. 841)
- "EtherCAT Diagnostics & Errors" (→ p. 845)
- "Practical Application: Using Trace Time To Measure CPU Load" (→ p. 499) - this topic provides a procedure for calculating CPU usage.
- "Re-import Kollmorgen UDFBs" (→ p. 849)
- "Troubleshooting KAS-IDE and SafePLC2" (→ p. 853)
- "Troubleshooting FSoE Safety Parameters" (→ p. 851)

23.1 FAQs

- "Basic" (→ p. 823)
- "Computer / Controller" (→ p. 826)
- "EtherCAT" (→ p. 827)
- "Performance" (→ p. 829)
- "Programming" (→ p. 831)
- "Setup" (→ p. 833)

23.1.1 Basic

Why does the Installer not Start when I insert the CD?

The Autorun feature may be deactivated.

1. Open an Explorer window to see the autorun.exe file.
2. Use the Run command in the contextual menu to manually start the installer.

Can I install more than one version of the KAS-IDE?

That depends on the version of KAS.

You may have one version of KAS-IDE v3.00 and earlier installed along with any number of later versions.

KAS version	Only 1 version	Multiple Installed Verions
< v3.00	✓	✗
v3.01 and later	✗	✓

Can I run more than one version of the KAS-IDE simultaneously?

Yes, as long as one of the versions is v3.02 or later.

With the release of v3.02 multiple instances of the KAS-IDE are permitted.

That includes running one older (<v3.02) instance and any number of newer instances. This includes multiple instances of the same version. The only limitation is available RAM.



TIP

The KAS-IDE supports simultaneously running multiple instances. Double-click a shortcut or project file, or selecting the application from the Start menu opens another instance. Double-click a project file more than once opens a copy of the project in another instance of the KAS-IDE.

How do I launch my project with a particular version of the KAS-IDE?

Window 10 and earlier

Right-click a KAS project file to choose which of your installed versions of the KAS-IDE to use for that instance.

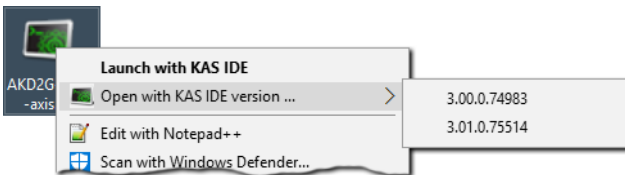

Windows 11

Right-click a KAS project file and click **Show more options**.

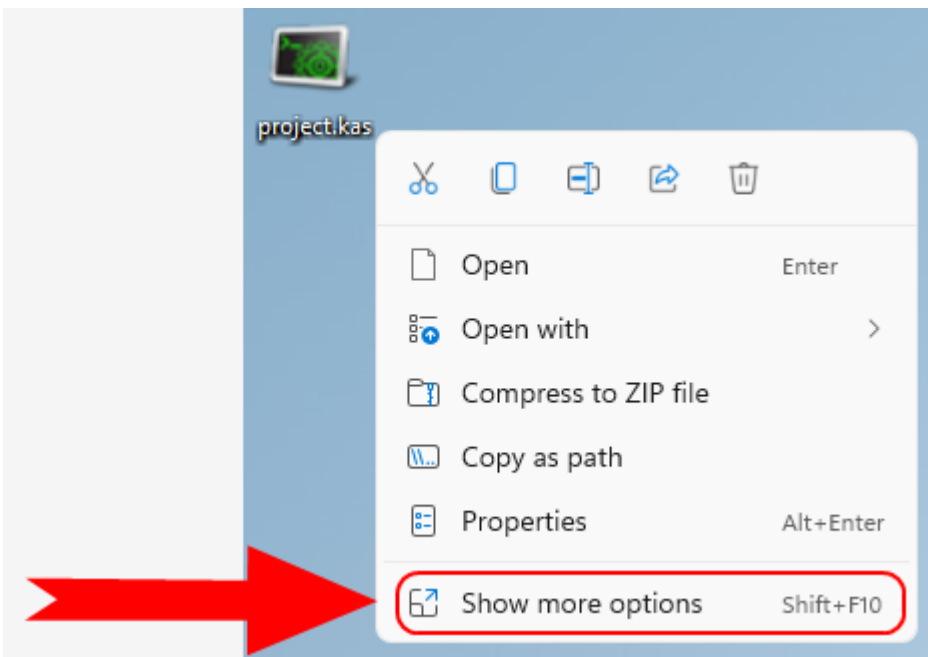

Or

Select the KAS project file and press <Shift+F10>.

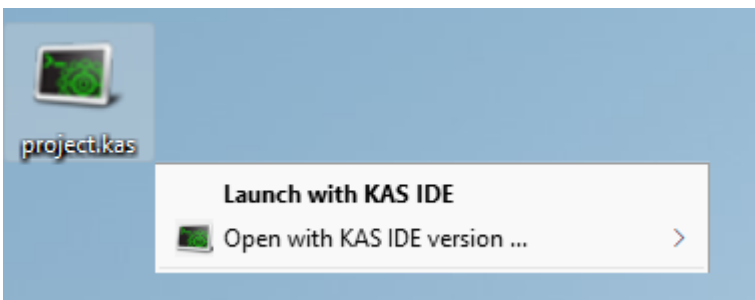

How do I choose the default version of the KAS-IDE to use?

The default version of the KAS-IDE is the one most recently installed.

This can be changed to a preferred version by changing an Environment Variable.

From the list of System variables, edit KAS_INSTALL_DIR. Enter the path to your preferred version.

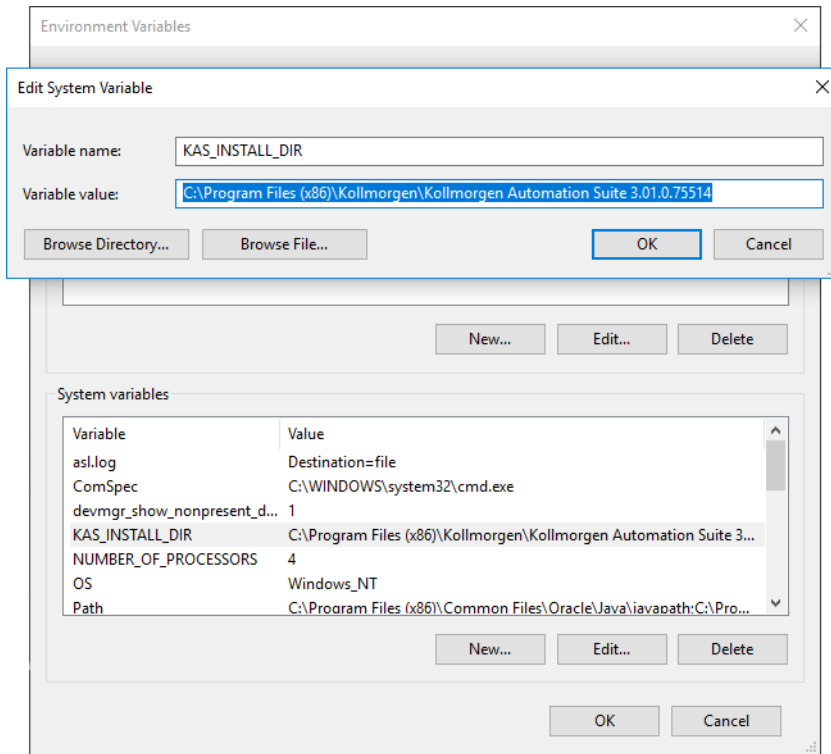

Can I copy and paste or drag and drop between instances of the KAS-IDE

Yes, the KAS-IDE supports copying and pasting between simultaneously running instances.

- This is supported in both the same version and different version numbers.
- This includes drag and drop for supported objects (e.g., FBD blocks).

The KAS-IDE attempts to recreate what you have copied, but there are some limitations.

Example: It may not automatically associate variables with a function.

If you copy and paste only a function block from an FFLD program, the assigned variables is not copied and pasted.

If you select the entire network, the KAS-IDE automatically creates the variables for you.

<p>Copying a block</p>	<p>Copying an entire network recreates assigned variables in the Dictionary</p>

NOTE
 Closing the KAS-IDE automatically clears the Clipboard.
 Anything that was copied is cleared from memory.
 This means you can not copy something, close the KAS-IDE, and then paste.

Why does the KAS-IDE not display all the items in the Project Explorer when I create a new project based on a template?

A side effect with some remaining files that were not deleted properly can interfere with your new project. To fix this issue:

1. Close your current project without saving.
2. Open Windows Explorer and go to **C:\Documents and Settings\user\Local Settings\Application Data\Kollmorgen\KAS\Project**, where "(user)" is the Windows' username you are currently logged in with.
3. Delete all the remaining files and folders.
4. You can now create your new project.

Where can I get the latest User Manuals?

Everything in our manuals may be found in the online help.

If you need a printable document or want stand-alone manuals, the documentation is available as [PDFs on KDN](#).

also see "Learning Kollmorgen Automation Suite" on page 42

Can I automatically save my files?

The KAS IDE does have an AutoSave feature which automatically backs up your crash recovery files at a specified interval.

This is set in the **Tools** menu.

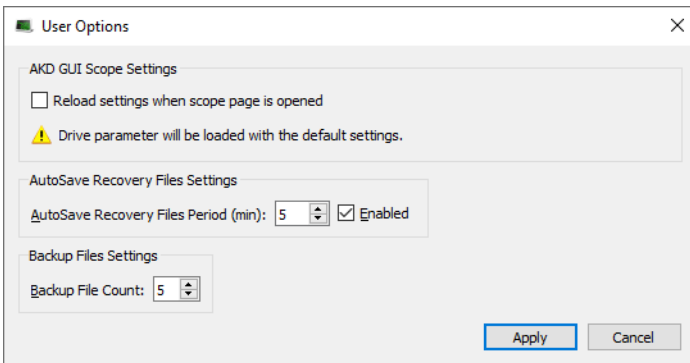

How does file recovery work?

With the AutoSave function, project files are saved for recovery.

More than one file may exist due to multiple versions of the KAS-IDE being installed or used.

- When you restart the KAS-IDE you are prompted to recover a found file.
- When there is more than one file, the recovery process starts with the latest date from the newest KAS-IDE version.
- Assuming you choose to recover the file it is opened and you may resume work but the older recovery files still exist.

The next time you launch the KAS-IDE, you are prompted to recover the next oldest file. Choosing to not recover the file will delete it, and you are prompted to open the next oldest file until none are left.

23.1.2 Computer / Controller

How many axes can the KAS-IDE manage in 1ms?

This number is mainly dependent upon the application and your PC's computing power.

An average number would be 20 axes/ms.

How can I see the CPU load between the PLC and motion parts?

This procedure allows you to determine if your controller is overloaded due to the PLC program or motion system load.

You can use the Softscope and the **Trace Times** button to display these CPU loads:

- Cycle Jitter (microseconds)
- Motion execution time (microseconds)
- PLC execution time (microseconds)
- Real Time Margin (microseconds)

To view the load:

1. Open the Softscope.
2. Plug four probes to any kind of data.
See "Mapping a Variable to the Oscilloscope" (→ p. 492).
3. In the Control Panel, click the [TraceTimes](#) button.

I cannot log into the controller's webpage. What do I do?

If you are unable to log into the controller's webpage using a valid user ID and password, the controller's file system may be corrupt.

To recover the system you will need to use the push buttons on the controller (see "Boot from Recovery Image (B2 Button)" (→ p. 384)) to recover the system.

How can I check if there is enough NVRAM space to store my Retain Variables?

See [click here...](#)

I have custom graphics in my project's control panel. Why don't they show up when the file is opened on other computers?

Graphics need to be made portable with a project, otherwise the KAS-IDE attempts to point to the original location of the graphic files.

To make graphics portable, copy them to

C:\Users\[user folder]\AppData\Local\Kollmorgen\Project\Controller\PLC.

After this the graphics are a part of the .KAS file.

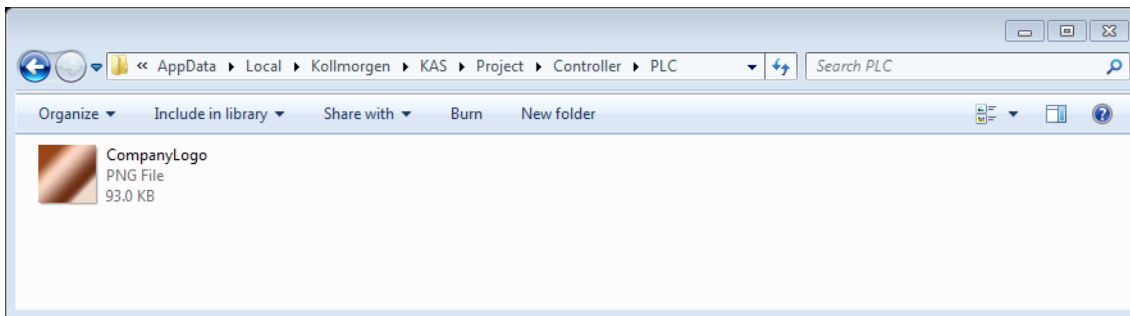

Why is the timestamp on the controller logs incorrect?

On the PCMM2G, the time is incorrect if all these conditions are TRUE:

- The controller loses power.
- Network Time Protocol (NTP) is disabled.
- There is no battery backup.

23.1.3 EtherCAT

Why am I getting an E33 error?

An "E33" (→ p. 676) occurs when the EtherCAT network fails to start when first loading a KAS project.

This typically occurs when the devices on the EtherCAT network do not exactly match the ENI file inside the KAS project.

- This can mean that devices were added, removed, or put in a different order.
- If this happens with a machine in the field that was working, it means that one or more devices are no longer being seen on the EtherCAT network because they are not powering on or an Ethernet cable came unplugged or broke.

Error Correction:

- Check the EtherCAT network wiring and devices state.
- Re-start the application.
- If you have the KAS-IDE software, you can scan the EtherCAT network to see if all the devices are found and in the correct order.

See "ESI and ENI Files" (→ p. 794).

Is EtherCAT limited to Master/Slave applications?

No. As with every real-time Industrial Ethernet system, one device (the master) has to be in charge of the network management and organize the Medium Access Control. With EtherCAT, Slave-to-Slave communication is supported either with:

- Topology dependent within one communication cycle ("upstream" device talks to "downstream" device).
- Topology independent within two cycles.

Since EtherCAT is so much faster than competing systems, slave-to-slave communication, using two cycles is faster.

What is the maximum number of EtherCAT nodes per network?

The maximum number of node addresses is 65,535.

Typically, the number of the nodes on the network is limited by the maximum EtherCAT frame size, which is 1500 bytes.

See the Frame Size in the "EtherCAT Master Settings tab" (→ p. 327) for more information.

When can I expect my SDO command to be completed?

If you need to rely on SDO communication to set the parameter of an EtherCAT device, you can do this with the ECATWriteSdo FB

Being asynchronous and based on the EtherCAT mailbox, the SDO communication is not deterministic.

- The EtherCAT master uses a polling mode to ensure the SDO command is completed.
- In operational mode, this polling is performed every 50 cycles¹.
 - As a consequence, you can expect the acknowledgment of your SDO command usually before less than 100ms.
- A good practice is to set the update rate for SDO communication in your PLC application each 25 cycles.

See also see "EtherCAT Motion Bus Concepts" on page 786 for more information.

When I compile I get a warning about the total number of PDO entries. How do I fix this?

The AKD2G has a limit on the number of PDO objects which can be mapped, depending on the sample rate.

Sample Rate	Cycle Time	Max. PDOs
4kHz	250µs	14 Rx, 14 Tx
2kHz	>500µs	30 RX, 30 Tx

This limitation can be hit during compilation with this error:

¹To avoid overloading the controller, this rate is set according to the communication load, as well as the duration the AKD takes to process commands

```
EtherCAT: ERROR: In AKD2G_1, the total number of entries for all selected Tx PDOs is greater than the max allowed at a cycle time of 250 µs: 17 > 14
```

There are three possible solutions.

- Increase the Cycle Time – see "EtherCAT Master Settings tab" (→ p. 327)
- Deselect unused PDOs – see "PDO Selection/Mapping tab" (→ p. 340)
- Delete unused objects – see "Delete a CoE Object" (→ p. 351)

Why is the PLC execution rate not the same as the EtherCAT rate with the KAS Simulator?

When the application runs on the KAS Simulator, the PLC execution rate is approximately 10ms.

KAS Simulator cannot execute the PLC programs faster because Windows is not able to handle timing less than 10ms.

23.1.4 Performance

Why does the PCMM2G take a long time to boot from the recovery image?

It is generally recommended to use USB 3.0 ([USB - Wikipedia](#)) or higher standard on the PCMM2G to have a better performance.

The normal recovery image boot up is around 30 to 40 seconds.

- If the controller 7-segment display is **H** for a longer period of time (more than two minutes), this delay could be because the recovery image is being flashed to an incompatible USB flash drive.
- This delay may not prevent the user from following the recovery procedure.
- See "Boot from Recovery Image (B2 Button)" (→ p. 384) for more information.

Contact Kollmorgen Technical Support if the issue is still not resolved using a USB 3.0 or higher.

I am having trouble with the WorkBench navigation tree. What can I do?

Due to excessive ASCII SDO commands or very slow Ethernet communication, the WorkBench tree may not fully populate or navigation may be unresponsive.

To recover from this situation:

1. Click the **Refresh Tree** button in KAS-IDEWorkBench view.

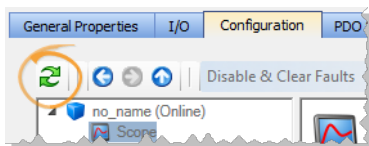

2. Disconnect and Reconnect the KAS-IDE to restart KAS-IDE-WorkBench communication.

What can I do if the KAS-IDE's embedded WorkBench (drive Configuration tab) is slow or unresponsive?

The status bar may display a warning if communication between the KAS-IDE, controller, and drive is too slow.

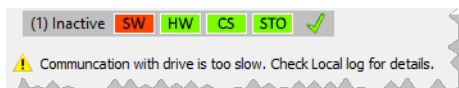

To begin troubleshooting, configure the Local log for **WARNING** level (or lower) and check for "*communication too slow*" messages.

The IDE-WorkBench navigation and views may become very slow or completely unresponsive if the average response time for drive communication is too long.

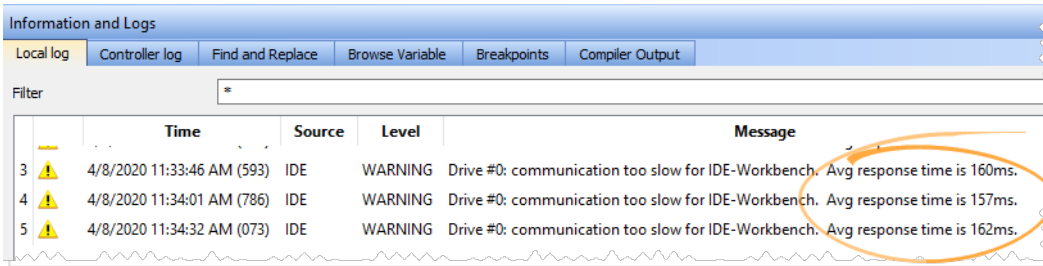

Communication delays between the KAS-IDE and Controller can be caused by degraded Ethernet bandwidth or high latencies.

You can use the Windows Resource Monitor (resmon.exe) and select **kas_ide.exe** to monitor and diagnose high latency and/or poor bandwidth.

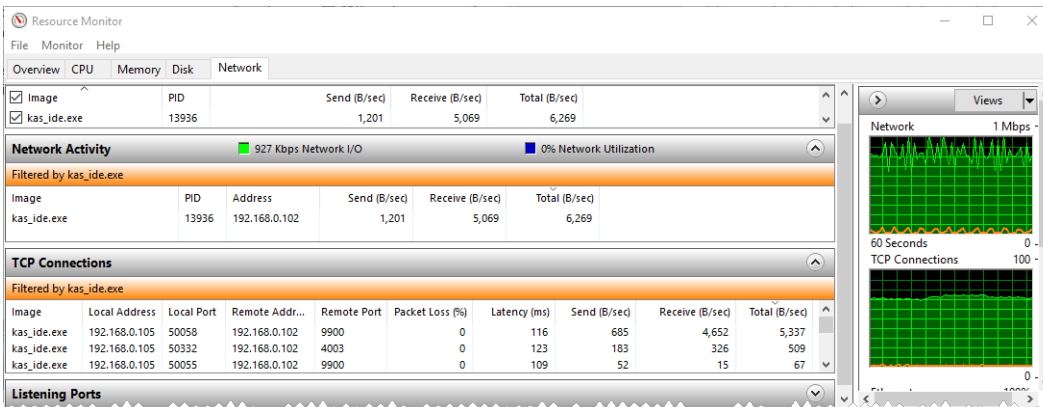

Communication delays between the Controller and Drive can occur while an application is running on the controller.

Degraded drive communication can be caused by excessive ASCII SDO commands from the application code.

- Check your application code for calls to DriveParamRead/Write(...), DriveParamStrRead(...), or ECATRead/WriteSdo(...), and minimize the frequency of these calls.
- Use "Online Configuration Mode" (→ p. 255) with KAS-IDEWorkBench to avoid ASCII SDO channel competition between your application and KAS-IDEWorkBench

I am having trouble connecting to drives with multiple WorkBench views/windows open. What can I do?

There are times when trying to connect to multiple drives simultaneously with WorkBench is problematic, particularly on slower networks.

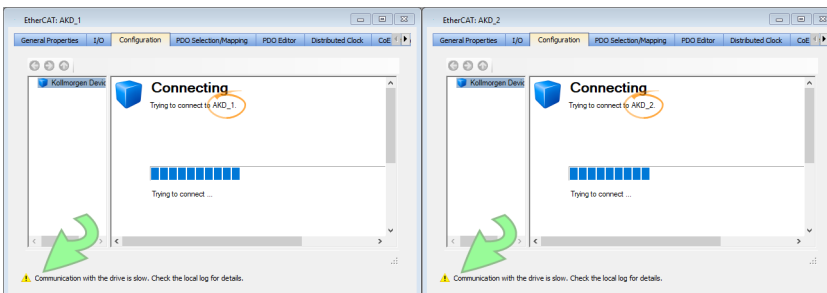

23.1.4.1 Resolution

- Close all of the open windows in the IDE workspace, leaving only one WorkBench window open.
- Connect the KAS-IDE and run the project or use Online Configuration mode.

These actions reduce the network and KAS-IDE loads. This allows the embedded WorkBench to establish communication and access the views.

To access multiple drives at the same time:

1. Open one WorkBench window
2. Wait for communication and initialization to complete successfully
3. Open each additional WorkBench window one at a time.
Allow enough time for each to successfully complete initialization.

23.1.5 Programming**How can I control the time execution for an SFC step?**

When you want to check the maximum time execution for an SFC step, you have to program this action based on the SFC alarm capability.

To show this status:

1. In the Dictionary, declare a Boolean PLC variable linked to the related SFC program.

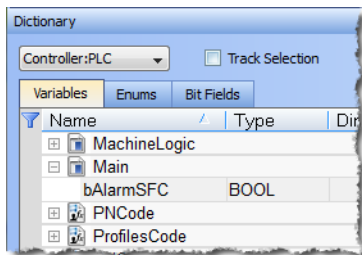

2. Add the instruction in the Actions tab related to the SFC step, with first parameter set to **A** (for Alarm).

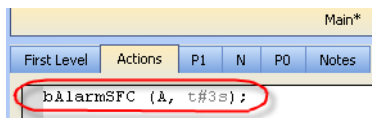

Figure 15-1: SFC Step - Timeout Alarm

How can I fix the Library Access issue?

If you open a project containing a link on a library which is no longer available, a warning is displayed. To fix this issue, refer to (→ # 211, What happens when a library no longer exists?)

What is the Fast Input?

The Fast Input allows an application to get information about the occurrence of an external event at a higher resolution than the cycle time.

For more details, see "Fast Inputs with Pipe Network Motion" (→ p. 552).

How do I implement feedback?

There are two kinds of feedback:

23.1.5.1 Primary Feedback

- With a S300 drive you can use a resolver for primary feedback.

Secondary Feedback

- If a secondary feedback is required with your S300 drive, you can use a BiSS feedback device.
 - If you use the same setup with an S300 drive, the S300's EXTPOS parameter has to be set to **-11**.
IMPORTANT: do not omit the negative sign!
 - To access secondary feedback, use a SAMPLER Pipe Network block.
- Use the MLSmpConPNAxis, MLSmpConPLCAxis, or MLSmpConECAT functions to configure the block.

How do I implement Torque Feed-forward?

Current drives that support torque feed-forward are the [S300](#) and [AKD](#) drives.

To use torque feed-forward, you have to rely on a CONVERTER Pipe Network block.

Use the MLCNVConnectEx function to configure the block.

The arguments must be:

- The Pipe Network block ID being configured.
- The ID of the axis to which the torque feed-forward is applied.
- The constant EC_ADDITIVE_TORQUE_VALUE.
- An ignored integer value (usually set to zero).

For more information, see:

- [Torque Feed-forward](#)
- [Guidelines for Choosing feed-forward Control in Industrial Applications](#)
- [Tuning with Feed-forwards](#)
- [Measurement-based Feed-forward Tuning](#)

How is Torque Feed-forward Scaled?

If I measure a number (e.g., 500) as an input at the [Converter](#) block which is connected with the PDO object (Additive Torque Value 0x60B2), how many Amps are fed in the current loop at the AKD?

```
Current loop feed-forward value = Rated current x IL.KBUSFF x input at
converter block / 1000
```

Example: With an AKD where:

Rated current	3A
IL.KBUSFF	1.0
Additive Torque (PDO object)	500 units

Then

```
IL.FF = 3 x 1.0 x 500 / 1000
IL.FF = 1.5A
```

What are the limitations with cams?

There is no limitation with the cams, the number of cams, the number of cam points, etc.

The limitation is only given by the processing power of your PC.

If a variable is associated with an I/O point value, would it get automatically updated?

Yes, I/O points represent the state of real world values.

How does the Pipe Network engine interact with a PLC program?

See "Use Motion Function Block for Pipe Network" (→ p. 739) for this information.

When I pressed Ctrl-V to paste Pipe Network blocks, nothing happened.

The system needs to know where to place the copied blocks.

Press Ctrl-V then use the mouse to point to where you want the copied blocks to be pasted.

How can I capture the correct pipe position?

There are network and mechanical delays in systems that make capturing a correct pipe position difficult.

To remove the delays, use a sampler block to capture the actual position of an axis.

This image shows how this works:

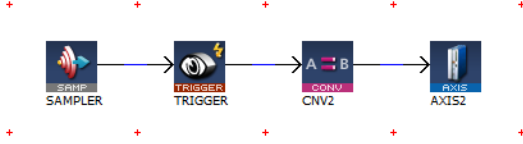

- This sampler block is configured to capture the actual position of axis 1.
 - The conversion and axis blocks are only needed to terminate the pipe.
 - MLTrigWriteDelay may still be needed to compensate for sensor delay.
- If you need to calculate the master pipe value corresponding to the captured axis position, add the difference between the axis command position and the master pipe value.

[A hardware limit flag is being thrown by a Pipe Network axis at the start of my program.](#)

If a hardware limit flag is being triggered at the program startup by a Pipe Network axis, MLAxisReAlign may need to be called immediately before motion occurs.

In this case, the distance to travel should be at least as long as the maximum distance the hardware limit flag can remain active.

23.1.6 Setup

[How are fieldbuses connected to the KAS Runtime?](#)

The fieldbus serially links all the drives to the industrial PC.

See the figures in (→ # 68, Different Implementations) for more information.

NOTE

When the KAS-IDE is used to deploy an automation system on a master drive (also known as programmable drive), the fieldbus serially links all the drives to the master drive.

[How does Kollmorgen Automation Suite communicate with a Host?](#)

KAS can communicate with outside world through Ethernet, CANopen, DeviceNet.

See (→ # 66, Communication and Fieldbus) for more information.

[Why does Online Configuration Mode not work after I reload the drive's factory default parameters?](#)

23.1.6.1 Description

This issue occurs with these actions:

1. Connect to the controller and download your application.
2. In the Project Explorer, open the EtherCAT properties.
3. Click the "Online Configuration Mode" (→ p. 255).
4. In the Project Explorer, right-click the AKD_1 and select **Load/Save Parameter...**

5. Select the **Factory Defaults...** command to reset the drive to its default parameters.

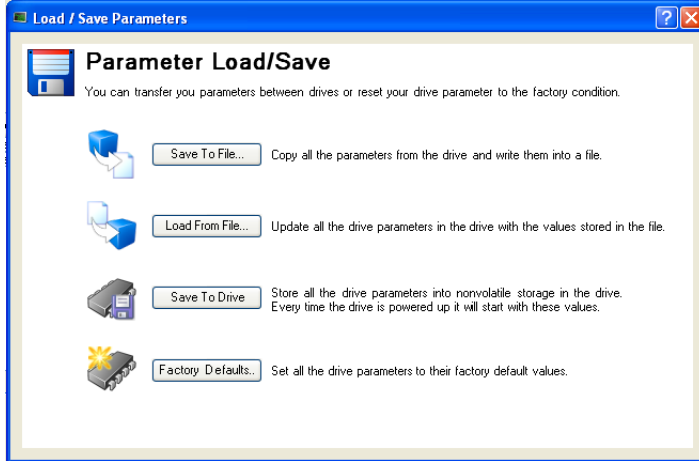

NOTE

Clicking the Online Configuration Mode leads to this error:

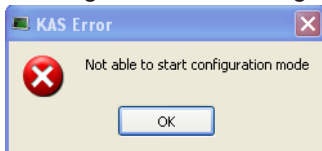

Reason

If you set the drive to its default parameters, then all the AKD parameters are restored and the unique ID (FBUS.PARAM03) used to identify the drive is lost.

Solution

You have to perform a new scan operation after setting the parameters to its default values.

TIP

You can also clear the **Write a unique ID** option in the XML configuration tab. See the [click here...](#) for more information.

How can I fix security issues?

If you encounter any security issues during execution of Kollmorgen Automation Suite, contact your IT department to set your proxy properly.

23.1.6.2 Firewall

You may have to define your firewall settings to allow accessing the IP addresses used by KAS (e.g., IP address of the target system or localhost IP address for the KAS Runtime Simulator: 127.0.0.1).

23.1.6.3 Port Numbers

Port numbers have to be set properly in your firewall settings to avoid any trouble during communication, such as when [downloading](#) the application to the target or plugging a probe to the Softscope.

Kollmorgen strongly recommends opening port numbers over 1024, as well as the range 502 to 520.

23.2 Compiler Errors

These errors may be seen when compiling a project.

"EtherCAT: ERROR: Failed to retrieve Vendor...", or
"EtherCAT: ERROR: Failed to retrieve EtherCAT device..."

These errors indicate either:

- The ESI file for the EtherCAT device is missing.
- Information is missing from the ESI file for a device and/or module.

Examples

```
EtherCAT: ----- Generating EtherCAT Network Information (ENI) file
-----
EtherCAT: ERROR: Failed to retrieve Vendor for vendorID=0x21 in ESI cache
Project compile failed
```

```
EtherCAT: ----- Generating EtherCAT Network Information (ENI) file
-----
EtherCAT: ERROR: Failed to retrieve EtherCAT device (vendorID=0x2,
productCode=0x44c2c52, revision=0x120000) in ESI cache
Project compile failed
```

Error Correction

1. Identify which EtherCAT devices or modules are listed as **Unknown** in the Project View.
2. Import an appropriate ESI file.

See "Unknown – Missing ESI File" (→ p. 141) for more information.

"EtherCAT: ERROR: In AKD_1, PDO object index 0x6040, subIndex 0 is redundant" or
 "Failed to export ENI file, check the logs for more details." or
 "EtherCAT: Warning : In AKD_1, PDO object index 0x3470, subIndex 4 is redundant."

These errors indicate redundant PDO entries.

Error Correction

See "Redundant PDO Entries" (→ p. 352) for more information.

Compile Optimized Code FAILED

These compiler outputs indicate a failure to compile the optimized C code:

```
Controller:PLC:> ----- Compile Optimized Code -----
Controller:PLC:> Compiling "C" code.
Controller:PLC:> ERROR: Failed to compile PLC "C" code.
Controller:PLC:> Compilation log:
...
Controller:PLC:> End of Compilation log
Controller:PLC:> Compile Time Elapsed:1.37 seconds
Controller:PLC:> ----- Compile Optimized Code FAILED -----
```

Error Correction

Locate and send these items to Kollmorgen technical support:

- The compilation log (copied from the compiler output).
- All the files in this directory:
 - %LOCALAPPDATA%\Kollmorgen\KAS\Project\Controller\PLC\CC\
 - The path can be copied and pasted into the Windows Explorer address bar.

To help us resolve the error with you, Kollmorgen technical support contact information can be found here:

- Global Support Contacts
- [Kollmorgen Support and Service](#)

Call or e-mail the appropriate support for your region.

Compiling optimized code fails due to user permissions

A possible cause for optimized PLC code to fail compilation is if the user does not have permission to write to an output file or folder.

Example 1: The file clog.txt is not writeable.

```
Controller:PLC:> ----- Compile Optimized Code -----
Controller:PLC:> ERROR: cannot remove old output file
"C:\Users\my.name\AppData\Local\Kollmorgen\KAS\Project\Controller\PLC\CC\c
log.txt"
Controller:PLC: > To resolve the issue, set the permissions on the file so
that it is writeable.
Controller:PLC:> Compile Time Elapsed:0.02 seconds
Controller:PLC:> ----- Compile Optimized Code FAILED -----
```

Example 2: The file main.c is not writeable.

```
Controller:----- Compile PLC -----
...
Controller:PLC:main
Controller:PLC:c:\users\my.name\appdata\local\kollmorgen\kas\project\contro
ller\plc\cc\main.c:
Cant write output file
Controller:PLC:appli
Controller:PLC:Error(s) detected
Controller:----- PLC failed -----
```

Error Correction

Change the file permissions to allow writing to the file.

"Unexpected complex data in expression." or
"Boolean expression expected after IF."

These errors indicate that the IF THEN ELSE ELSIF END_IF condition used in the application code does not evaluate to a BOOL expression.

```
Controller:----- Compile PLC -----
...
Controller:PLC:MCFB_Jog
Controller:PLC:MCFB_Jog: (16): Unexpected complex data in expression
Controller:PLC:MCFB_Jog: (16): Boolean expression expected after IF
Controller:PLC:MCFB_Jog: (19): END_IF: New statement expected
Controller:PLC:Error(s) detected
Controller:----- PLC failed -----
Controller:----- Device compile failed -----
...
Project compile failed
```

This compile error can happen when a non-compliant syntax is used for verifying the function block outputs.

- In the KAS v4.0 and earlier releases, it was possible to use the function block return statement in the same way as function return values.
 - This could result in undefined behavior.
- In KAS v4.0 and later releases, the compiler generates an **Unexpected complex data in expression** error for non-compliant syntax.

```
IEC 61131-3 Non-Compliant Syntax:
If inst_functionBlock(myVar1) Then
    // ...
End_If;
```

```
IEC 61131-3 Compliant Syntax:
inst_functionBlock(myVar1);
If inst_functionBlock.Q Then
    // ...
End_If;
```

Error Correction

1. Identify the code that caused compile error.
2. If the error is due to non-compliant syntax, replace this code using compliant syntax for the corresponding function block.

Example: Non-compliant Syntax

```
IF Inst_r_trig(Inst_TON.Q) THEN
    Inst_DriveParamRead( TRUE, any_to_int(Inst_MC_ReadParam.Value),
'DRV.FAULT1' );
END_IF;
```

Example: Compliant Syntax

```
Inst_r_trig(Inst_TON.Q);
IF Inst_r_trig.Q THEN
    Inst_DriveParamRead( TRUE, any_to_int(Inst_MC_ReadParam.Value),
'DRV.FAULT1' );
END_IF;
```

WARNING

UDFBs and libraries can have improper syntax.

These Kollmorgen UDFBs have been corrected and can be re-imported into the application code.

See [Re-import Kollmorgen UDFBs](#) for more information.

- FB_AKDFItRpt
- FB_AxisPlsPosModulo
- FB_AxisPlsPosNoModulo
- FB_S700FitRpt
- MCFB_AKDFault
- MCFB_DriveFault
- MCFB_Jog
- MCFB_StepAbsSwitchFastInput
- MCFB_StepLimitSwitchFastInput
- MLFB_DriveFault
- MLFB_PlsPosFw
- MLFB_PlsPosFwBw
- MLFB_PlsTimeFw

23.3 Compiler Warnings

These messages explain the cause of the warning messages from the compiler.

- "10001 - Macro Redefinition" (→ p. 838)
- "10002 - Not IEC Compliant" (→ p. 838)
- "10003 - Same Name to a Global Variable and a Local Variable" (→ p. 838)
- "10014 - Empty Line Ignored in Signal Resource (No Time Defined)" (→ p. 838)
- "10015 - On Line Change may not be Possible: Too Many POUs or Variables" (→ p. 838)
- "10019 - Definition of the Block was Changed" (→ p. 839)
- "10020 - Backward Jump may Block the Target Cycle" (→ p. 839)
- "10021 - FB Instance Missing (Unsafe)" (→ p. 839)
- "10022 - Output Used Before it is Set. Execution may be Unsafe" (→ p. 839)
- "10023 - Loop Instructions may Block the Target Cycle" (→ p. 839)
- "10024 - Implicit Loops may be Unsafe" (→ p. 839)
- "10025 - Input Parameters are not Considered as IN/OUT" (→ p. 840)
- "10026 - Backward Jumps may Block the Cycle" (→ p. 840)
- "10030 - Invalid PRINTF Format" (→ p. 840)
- "10033 - LREAL# Prefix is Required to Avoid Loss of Accuracy" (→ p. 840)
- "10034 - Loop Instructions may Block the Target Cycle" (→ p. 840)
- "10037 - The Same Modbus Address is Used for Several Variables" (→ p. 840)

23.3.0.1 10001 - Macro Redefinition

This warning occurs when the same identifier is used for several definitions.

Example:

- #define PI 3.14
- #define PI 3.1416

This can also happen if the same identifier is used for a global definition and definition local to a program.

- If an identifier is reused, the compiler uses the last definition.
- If the identifier is defined both in global and local definitions, the local one is used.

23.3.0.2 10002 - Not IEC Compliant

This warning occurs when the use a semantic or block not compliant with the IEC 61131-3 standard.

This can occur in case of a specific block (e.g., **blink**) or some C-like operators (e.g., **Addition +** or **EQ =**).

23.3.0.3 10003 - Same Name to a Global Variable and a Local Variable

This warning occurs when the same name is used for a global variable and a variable local to a program.

- If the variable name is used in the body of the program, it represents the local variable.
- It is strongly **not** recommended to reuse names because this creates unclear programming and may lead to confusion and errors.

23.3.0.4 10014 - Empty Line Ignored in Signal Resource (No Time Defined)

This warning occurs when an empty line is inserted in the definition of a signal resource.

The compiler considers a line as empty if the line has no time value defined.

23.3.0.5 10015 - On Line Change may not be Possible: Too Many POUs or Variables

If Online Change is enabled, this warning occurs when more than 10 POUs in an application.

- Ignore this warning.
 - This warning is for a future feature, when the number of additional POUs during Online Change is configurable.

23.3.0.6 10019 - Definition of the Block was Changed

This warning occurs when the set of arguments of a block used in a FBD diagram has changed and diagram was not updated with the new block interface.

Re-select the block and check its input and output parameters in the program referred to by the message.

23.3.0.7 10020 - Backward Jump may Block the Target Cycle

This warning highlights the use in an FBD diagram of:

- A backward **Jumps JMP JMPC JMPNC JMPCN** instruction.
- A loop instruction (**REPEAT UNTIL END_REPEAT** or **WHILE DO END_WHILE**) put on a network break.

When using these programming semantics, **be very careful** the loop is finite and it brings no risk to hang the PLC execution cycle.

23.3.0.8 10021 - FB Instance Missing (Unsafe)

This warning occurs when a function block is used in an FBD diagram without any instance specified.

- In some conditions, the compiler may authorize this and an instance is automatically created.
 - This is not safe.
 - This can lead to unpredictable errors if you operate an On Line Change.
- Always specify a valid declared instance for a function block call.

23.3.0.9 10022 - Output Used Before it is Set. Execution may be Unsafe

This warning occurs when a sub-program uses the value of a local variable before setting its value.

This can lead to unpredictable errors if you operate an On Line Change.

23.3.0.10 10023 - Loop Instructions may Block the Target Cycle

This warning highlights the use in an FBD diagram of:

- A backward **Jumps JMP JMPC JMPNC JMPCN** instruction.
- A loop instruction (**REPEAT UNTIL END_REPEAT** or **WHILE DO END_WHILE**) put on a network break.

When using these programming semantics, **be very careful** the loop is finite and it brings no risk to hang the PLC execution cycle.

23.3.0.11 10024 - Implicit Loops may be Unsafe

This warning indicates an implicit loop in a FBD diagram.

- An implicit loop is a set of links in between functions without any variable specified in the entire flow.
Example:

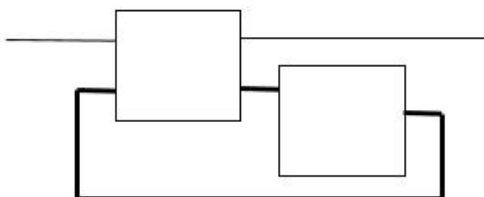

- This can lead to unpredictable errors if you operate an On Line Change.
- To avoid any problem, insert a variable on this link.

23.3.0.12 10025 - Input Parameters are not Considered as IN/OUT

This warning indicates that a sub-program assigns the value of one of its INPUT parameters.

- This can be correct in some use cases.
- Avoid any confusion by copying the input parameter to a temporary variable and use it in the sub-program.

23.3.0.13 10026 - Backward Jumps may Block the Cycle

This warning highlights the use in an FFLD of a backward **Jumps JMP JMPC JMPNC JMPCN** instruction (i.e., a jump to a rung defined before).

When using these programming semantics, **be very careful** the loop is finite and it brings no risk to hang the PLC execution cycle.

23.3.0.14 10030 - Invalid PRINTF Format

This warning indicates a program uses a call to the **printf** function with a potentially unsupported “%” format.

Only “%ld”, “%lu”, “%lx” formats are supported by all systems.

23.3.0.15 10033 - LREAL# Prefix is Required to Avoid Loss of Accuracy

By default, REAL and LREAL constants are interpreted as REAL (single precision).

- If this constant is used in an LREAL expression or statement, it is converted to LREAL (double precision) and this will lose its accuracy.
 - To avoid this, always specify the LREAL# prefix for LREAL expressions.
- Floating-point numbers are store in memory in binary radix.
 - Even a simple decimal value(e.g., 1.3) is not finite when coded in binary.

23.3.0.16 10034 - Loop Instructions may Block the Target Cycle

This warning highlights the use in an ST Language program of a loop instruction:

- **FOR TO BY END_FOR**
 - Even a FOR loop with bounds may become infinite if the index variable is forced within the body of the loop.
- **REPEAT UNTIL END_REPEAT**
- **WHILE DO END_WHILE**
- When using these programming semantics, **be very careful** the loop is finite and it brings no risk to hang the PLC execution cycle.

23.3.0.17 10037 - The Same Modbus Address is Used for Several Variables

This warning indicates a MODBUS configuration (master or slave) contains two or more variables mapped to the same MODBUS address.

- This can make sense in some use cases (e.g., map two variables on the same input) and can really highlight a configuration error.
 - Example: Two variables mapped on the same output bit or register.

23.4 Connect Remotely

You can connect to a controller from an external network using [VPN](#) or other tunneling protocol.

You must open these ports which are used by KAS to connect to a controller:

Port	Component / Protocol Using the Port
80	KAS-IDE: <ul style="list-style-type: none"> • Controller Web Server • Download PLC application • Runtime front end communication. <ul style="list-style-type: none"> • This is necessary for the connection to the runtime. • If port 80 is used by any other application, the Simulator uses an alternate port available in the host computer for HTTP communication.
502	HMI and other Modbus devices to communicate with Modbus TCP.
2222	EtherNet/IP communication.
4002	KAS-IDE: Oscilloscope variable monitoring.
4003	KAS-IDE: <ul style="list-style-type: none"> • Communication with the PLC Virtual Machine. • This is necessary for the connection to the runtime.
9900	KAS-IDE: <ul style="list-style-type: none"> • Communication with the runtime engine; WorkBench views. <ul style="list-style-type: none"> • This is necessary for the connection to the runtime.
34962	PROFINET communication.
34964	PROFINET communication.
44848	EtherNet/IP communication.

23.5 CPU Load Reduction Techniques

There are several things you can change to reduce the CPU load:

- Reduce the cyclic update rate by increasing the [Cycle Time](#) in the EtherCAT view. This will have the biggest impact to improve the RealTimeMargin.
- Reduce the number of axes. This will decrease the MotionExecTime.
- Distribute the PLC program execution across multiple PLC cycles (see "Define the PLC Cycle" on page 219). This will decrease the PLCProgExecTime.

23.6 EtherCAT Coupler Error Handling And Diagnosis

This section provides information about the diagnostic LEDs for the EtherCAT Coupler (AKT-ECT-000).

NOTE

This section is an excerpt of the [EtherCAT Coupler Technical Manual](#).

23.6.1 EtherCAT Diagnostic LEDs

After switching on, the ETHERCAT Bus Coupler immediately checks the connected configuration. Error-free start-up is indicated when the red I/O ERR LED goes out. If the I/O ERR LED blinks, an error in the area of the terminals is indicated. The error code can be determined from the frequency and number of blinks. See below for more information.

The ETHERCAT Bus Coupler has respectively a green and yellow LED at the RJ45 plug sockets, which indicate the state of the fieldbus (Figure 4.1). The RUN and ERROR LEDs (upper middle) indicate the state of the EtherCAT State Machine.

On the upper right hand side of the Bus Couplers are two more green LEDs that indicate the supply voltage. The left hand LED indicates the presence of the 24 V supply for the Bus Coupler. The right hand LED indicates the presence of the supply to the power contacts.

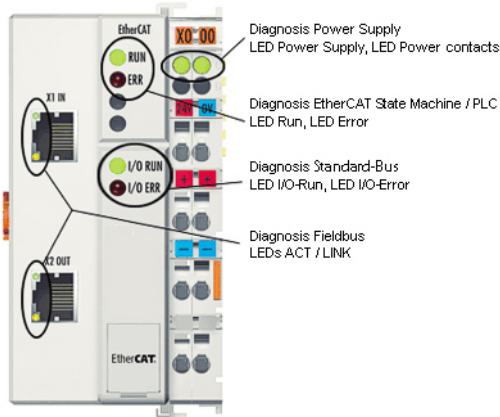

Figure 15-2: ETHERCAT Coupler Diagnostic LEDs

23.6.2 EtherCAT LED Power Supply Diagnosis

LED	Display	Description
Power Supply	Green Off	No operating voltage connected
	Green On	24 VDC operating voltage connected
Power Contacts	Green Off	No 24 VDC power connected to the power contacts
	Green On	24 VDC power connected to the power contacts

23.6.3 EtherCAT LED Off Power Supply Diagnosis

LEDs	
Left Green LED Off	Bus coupler has no power
Right Green LED Off	No 24 VDC power connected to the power contacts

23.6.4 LEDs for EtherCAT State Machine/PLC Diagnosis

LEDs	Display	Status	Description	
Run	Green	Off	Init	State of the EtherCAT State Machine: INIT = Initialization
		Blinking	Pre-operational	State of the EtherCAT State Machine: PREOP = Pre-Operational
		Single Flash	Safe operational	State of the EtherCAT State Machine: SAFEOP = Safe-Operational
		On	Operational	State of the EtherCAT State Machine: OP = Operational
		Flashes	Bootstrap	State of the EtherCAT State Machine: BOOT = Bootstrap (Update of the coupler firmware)
Error	Red	Off	–	No errors
		Blinking	Err-Operational No Communication	PLC error / Lost frames

23.6.5 LEDs for EtherCAT Connection Diagnosis

LEDs	Display	Status	Description	
LINK (X1 IN)	Yellow	Off	No connection with the previous EtherCAT client	
		On	Linked	Previous EtherCAT-client connected
ACT (X1 IN)	Green	Blinking	Active	Communication with the previous EtherCAT client
		Off		No connection with the previous EtherCAT client
		On		No communication with the previous EtherCAT client
LINK (X2 OUT)	Yellow	Off	Linked	Next EtherCAT client connected
		On	Active	Next EtherCAT client connected
ACT(X2 OUT)	Green	Blinking	Active	Communication with the next EtherCAT client
		Off		No connection with the next EtherCAT client
		On		No communication with next previous EtherCAT client

23.6.6 LEDs for EtherCAT Data Diagnosis

LEDs		Display	Status	Description
I/O-Run	Green	Off	–	EtherCAT Bus inactive
		On	–	EtherCAT Bus active
LED Red; I/O Error	Error Code Argument	Description	Remedy	
Persistent, continuous blinking		EMC problems	<ul style="list-style-type: none"> • Check power supply for overvoltage or under voltage peaks • Implement EMC measures • If a EtherCAT Bus error is present, it can be localized by a restart of the coupler (by switching it off and then on again) 	
1 Pulse	0	EEPROM checksum error	Set manufacturer's setting with the configuration software	
	1	Code buffer overflow	Insert fewer Bus Terminals. The programmed configuration has too many entries in the table Software update required for the Bus Coupler	
	2	Unknown data type	Software update required for the Bus Coupler	
2 Pulses	0	Programmed configuration has an incorrect table entry	Check programmed configuration for correctness	
	n (n > 0)	Table comparison (Bus Terminal n)	Incorrect table entry	
3 Pulses	0	EtherCAT Bus command error	<ul style="list-style-type: none"> • No Bus Terminal inserted • One of the Bus Terminals is defective; halve the number of Bus Terminals attached and check whether the error is still present with the remaining Bus Terminals. Repeat until the defective Bus Terminal is located. 	
4 Pulses	0	EtherCAT Bus data error, break behind the Bus Coupler	Check whether the n+1 Bus Terminal is correctly connected; replace if necessary.	
	n	Break behind Bus Terminal n	Check whether the Bus End Terminal is connected.	
5 Pulses	n	EtherCAT Bus error in register communication with Bus Terminal n	Exchange the nth Bus Terminal	

LED Red; I/O Error	Error Code Argument	Description	Remedy
14 Pulses	n	nth Bus Terminal has the wrong format	Start the Bus Coupler again, and if the error occurs again then exchange the Bus Terminal
15 Pulses	n	Number of Bus Terminals is no longer correct	Start the Bus Coupler again. If the error occurs again, restore the manufacturers setting using the configuration software
16 Pulses	n	Length of the EtherCAT Bus data is no longer correct	Start the Bus Coupler again. If the error occurs again, restore the manufacturers setting using the configuration software

23.7 EtherCAT Diagnostics & Errors

23.7.1 EtherCAT Diagnostics

The EtherCAT nodes provide several types of diagnostic information through various registers.

The KAS controller uses these diagnostic registers to detect error conditions in the EtherCAT network.

This can include:

Diagnostic Register	Description
Physical Link status	Indicates if a hardware connection between two nodes is established.
Link Lost Counter	Indicates how many connection lost events have occurred between two nodes. Some EtherCAT devices do not detect the lost link event.
Rx Error Counter	This counter is incremented when the node detects any signal error detected by the hardware.
Rx Invalid Frame Counter	Invalid frame error is detected when the Cyclic Redundancy Check (CRC) does not match the received frame CRC.
Forwarded Rx Error Counter	Frame error detected by the previous node and forwarded to this node.
EtherCAT Processing Unit Error Counter	Counts errors in the EtherCAT frames such as frame length or a non-EtherCAT frame. Not all EtherCAT devices support this register.

- **Application Started:** When the application is started, the KAS controller resets these items of all the nodes:
 - Link Lost Counter
 - Rx Error Counter
 - Rx Invalid Frame Counter
 - Forwarded Rx Error Counter
 - EtherCAT Processing Unit Error Counter registers.
- **Application Running:** While the application is running, the KAS controller monitors every cyclic frame and detects any missing or invalid frames.
 - If any frame is missed or invalid, it generates an "A38" (→ p. 681) alarm.
- **Application Stopped:** When the application is stopped, the controller reads the EtherCAT node diagnostic registers and process them.
 - If any error condition is detected, an EtherCAT diagnostic log message is generated.
 - The log messages can be used to identify the location of the communication failure.

The node register of **Link Lost Counter**, **Rx Error Counter**, **Rx Invalid Frame Counter**, **Forwarded Rx Error Counter**, and **EtherCAT Processing Unit Error Counter** have non-zero values when a cable disconnection or an EtherCAT frame corruption occurs.

These examples indicate a communication failure occurred between Node 0 and Node 1.

```
EtherCAT | WARNING | EtherCAT diagnostics: AKD_1, port B (out) RX Error Counter is 255
```

```
EtherCAT | WARNING | EtherCAT diagnostics: AKD_2, port A (in) RX Error Counter is 255
```

23.7.2 EtherCAT Error Messages

This section covers these error messages linked to the EtherCAT motion bus displayed in the "Information and Logs window" (→ p. 102) window:

```
Working Counter failure limit exceeded due to failed node response to cyclic commands. Stopping EtherCAT network cyclic communication.
```

```
Link Error detected! Please, check controller connection.
```

```
Slave %s is not responding to acyclic frame. Please, check power supply or connection.
```

These messages can appear because of these causes:

Error	Case Description	Results
Wrong / Missing Device	<p>The XML network configuration file contains the list of all EtherCAT devices present in the network.</p> <p>At the EtherCAT initialization phase, the master checks that:</p> <ul style="list-style-type: none"> • Every physical device in the network corresponds to the configured devices. <ul style="list-style-type: none"> • The master detects if the configuration does not match the physical devices. • The Standard I/O Couplers and I/O slices are correct by adding the proper commands in the network configuration file. <ul style="list-style-type: none"> • This allows the detection of wrong or missing Standard I/O Coupler. 	<ul style="list-style-type: none"> • An Error log is generated with the relevant information. • The EtherCAT startup is aborted, as well as the startup of the machine.

Error	Case Description	Results
Link Loss / Device Fault	<ul style="list-style-type: none"> This kind of error can appear anytime in the EtherCAT communication, typically when a cable is disconnected, cut, or whenever an EtherCAT device is damaged. The master has a mechanism that detects such situations. 	<ul style="list-style-type: none"> An Error log is generated with the relevant information. All still-reachable axes must be stopped and powered off. The EtherCAT communication is aborted. If the network is cut, the drives on the side of the network disconnected from the master are moved into an error state (F29). <ul style="list-style-type: none"> They are automatically stopped and powered off. <div data-bbox="995 701 1198 734" style="background-color: #333; color: white; padding: 2px; text-align: center;">NOTE</div> <p data-bbox="995 734 1453 831">It can be necessary to put the axes in a safe position before powering it off (this action is application dependent).</p>
Frame Loss	<ul style="list-style-type: none"> For security, all frames sent must be received in a given timeout period (at least before the next cycle is started). The master detects this case by managing the appropriate timeout watchdogs. 	<ul style="list-style-type: none"> An Error log is generated with the relevant information. The EtherCAT communication is aborted.
Working Counter	<ul style="list-style-type: none"> When EtherCAT master (KAS controller) sends out an EtherCAT data gram, it sets the Working Counter (WC) value to 0. The nodes receiving the frame increment the WC at the hardware level according to a precise rule. When the controller receives the frame, it compares the WC with the expected value to detect error conditions. <p data-bbox="544 1541 938 1603">Possible reasons for the working counter error:</p> <ul style="list-style-type: none"> The slave EtherCAT device does not exist or cannot be physically reached due to connector/cable failure. Slave hardware failure. Slave is still busy with a previous command and is not ready. 	<ul style="list-style-type: none"> The controller generates an A31 alarm and logs a warning message when the WC values does not match the expected value. When the controller detects three such working counter failures within 1000 EtherCAT frames, it generates an "E30" (→ p. 675) error and shuts down the EtherCAT communication.

23.7.2.1 Other Messages Linked to EtherCAT

See "Communication and Fieldbus" (→ p. 66) for more information.

This message is displayed if an error or inconsistency is discovered during the parsing of the XML file when the application is started:

```
Unable to open EtherCAT config file <file-name>
<file-name>:<line>:<column>: <parsing error>
```

23.7.3 Example: EtherCAT Communication Diagnosis Steps

These are the steps to diagnose EtherCAT communication errors.

Examples are for how an application program can help a technician detect the issue and repair it.

23.7.3.1 Diagnosing EtherCAT Communication Errors

This flow chart explains the steps involved in diagnosing the EtherCAT errors.

TIP

Click the blue fields in the flow chart to see sample code that can be used in a program to help with diagnosis.

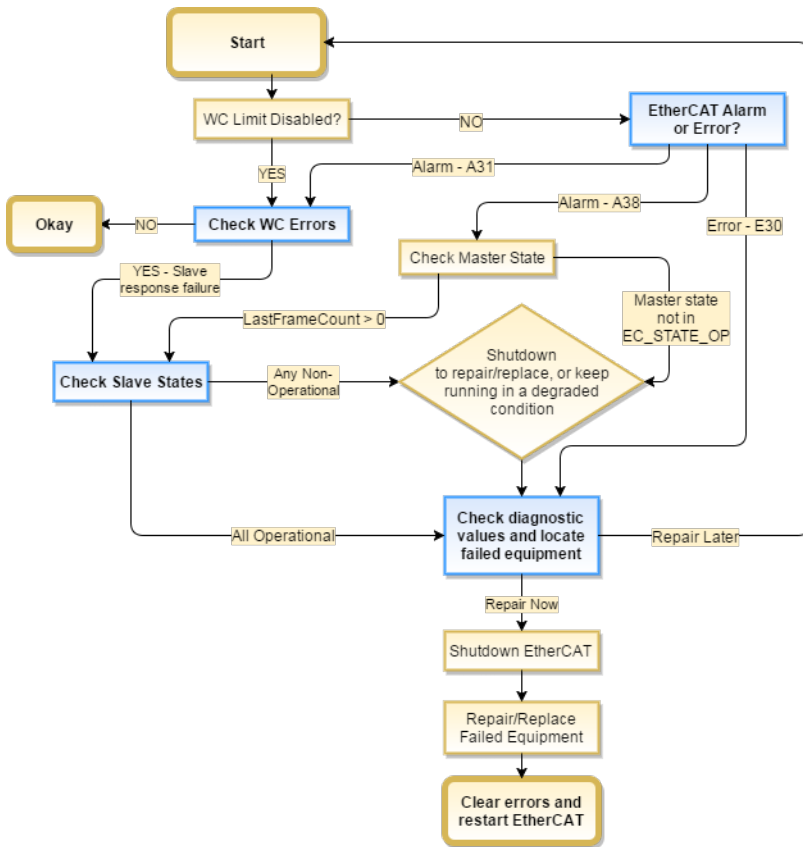

23.7.3.1.1 Code Examples for Diagnosing EtherCAT Communication Errors

Check for Working Counter Errors

This sample code checks for any Working Counter failure using the function ECATWCStatus.

If there is one or more working counter errors, the return value is greater than 0 (zero).

```
WC_ErrorCount := ECATWCStatus( 0 );
IF WC_ErrorCount > 0 THEN
    WC_error :=TRUE; // There is a communication problem.
ELSE
```



```

    WC_error := FALSE; // No communication problem
END_IF;

```

Check for existing EtherCAT Alarms and Errors

The GetCtrlErrors function is used to get the Errors and Alarms in the controller that are related to EtherCAT.

```

ControllerErrorStatus:= GetCtrlErrors(ActiveError, ActiveAlarm) ;
A31Active := ActiveAlarm[31]; // True if A31 is active.
    A38Active := ActiveAlarm[38]; // True if A38 alarm is active
    E30Active := ActiveError[30] // True if E30 is active.
    // Process the alarms and Errors here.

```

Check the Device States

The ECATDeviceStatus function block is used to read the device state of the application.

```

Inst_ECATDeviceStatus(True, slaveAddress);
IF Inst_ECATDeviceStatus.Done THEN
    IF Inst_ECATDeviceStatus.LinkStatus = EC_LINK_NO_COMMUNICATION THEN
        device_not_reachable := TRUE; // Device is not reachable. Link to the
device is broken.
    END_IF
    IF Inst_ECATDeviceStatus.State <> EC_STATE_OP THEN
        device_not_in_OPMODE := TRUE; // Slave is not in Operational mode.
    END_IF
END_IF;

```

Check the Connections for Errors

This sample code uses the ECATCommErrors function block to identify the connections that have errors.

```

Inst_ECATCommErrors( TRUE, connections);
IF Inst_ECATCommErrors.Done THEN
    IF Inst_ECATCommErrors.ConnectionCount > 0 THEN
        // Process the connection errors here.
    END_IF;
END_IF

```

TIP

See the article [Building KAS Applications with Built-in EtherCAT Diagnostics](#) on KDN for a code sample and project file that uses EtherCAT diagnostics.

23.8 Re-import Kollmorgen UDFBs

1. In the Project Explorer, expand **Subprograms**.

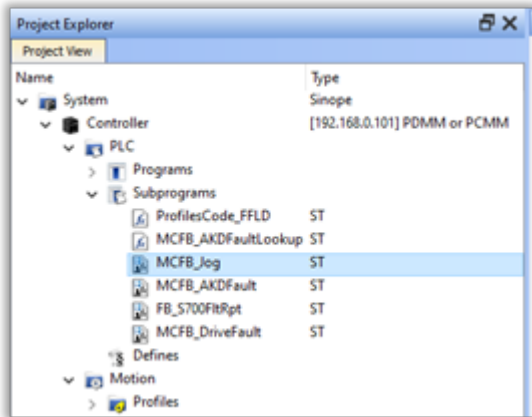

2. Right-click the Kollmorgen UDFB with the improper syntax and click **Delete**.

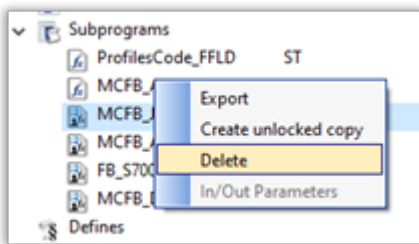

A confirmation message appears.

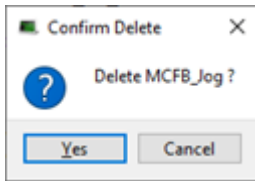

3. Click **Yes** to confirm deletion.
4. Click the **Libraries** tab.
5. Locate the UDFB that was just deleted.

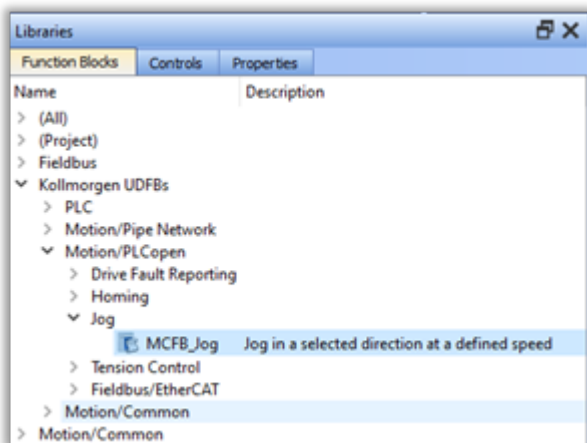

6. Drag and Drop the selected UDFB to any program in the PLC code.

NOTE

This step copies the latest UDFB subprogram from the Kollmorgen library to the PLC code.

NOTE

Press the **key** or click the **X** in the popup to avoid creating an instance of the function block in the program and delete the new code that was added here.

7. Compile the program and verify that the compilation error is resolved.

23.9 Troubleshooting FSoE Safety Parameters

Safety parameters can be set by using the FSoEParamsInit function block.

This operation requires proper configuration of the FSoE master, FSoE safety devices, and the EtherCAT master (the AKD PDMM or PCMM).

Are there any errors?

First, check the ErrorID output of FSoEParamsInit.

There are some common failure cases that can be identified from the ErrorID values and the controller log messages.

ECERR_DEVICE_NOTREADY	<p>The Safety parameters can only be sent after the EtherCAT network state is in op-mode. To verify EtherCAT is ready:</p> <ul style="list-style-type: none"> • Verify the motion engine is running. <ul style="list-style-type: none"> • Use MLMotionStatus to verify the status is MLSTATUS_RUNNING before calling FSoEParamsInit. • Check the The EtherCAT state directly. <ul style="list-style-type: none"> • Use ECATMasterStatus to verify the state is EC_STATE_OP.
ECERR_DEVICE_FSOE_MASTER_INVALID	<p>This error is generated if the argument specified for FSoEParamsInit's FSoEMasterAddress is not an FSoE master.</p> <ul style="list-style-type: none"> • Check to ensure that the EtherCAT address specified for the FSoE master is correct. • Check the supported FSoE masters list.
ECERR_DEVICE_TIMEOUT	<p>This can occur if the FSoE master is not responding or is not configured properly.</p> <ul style="list-style-type: none"> • Check the FSoE master diagnostic LEDs, Error Codes/Messages, log messages, and any other diagnostic tools available from the FSoE master vendor. • Example: With the BBH SCU-1-EC FSoE master, use the SafePLC2 software.

FSoEParamsInit(...) is successful but the AKD2G Safety State does not reach 6 - Normal operation.

If FSoeParamsInit(...) is successful but the AKD2G Safety State does not reach 6 - Normal operation, then the CRC expected by the AKD2G SMM does not match the CRC sent by the FSoE master.

1. Use WorkBench or the KAS-IDE's integrated WorkBench (Configuration tab for the AKD2G) to diagnose.
2. Click the **Safety** item in the status bar.
 - If FSoE is operating normally:
 - The Safety State is 6 - Normal Operation.
 - The FSoE State is 54 - Process Data.

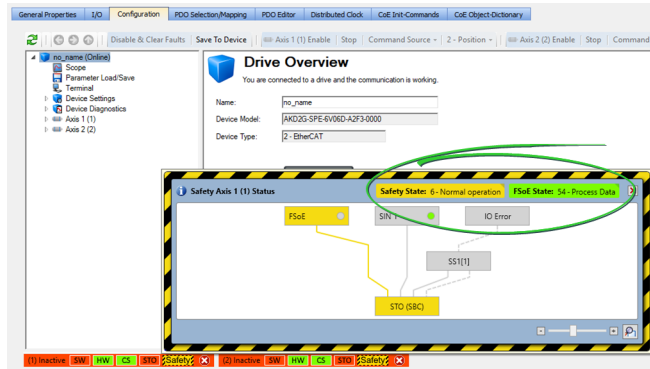

- If the CRC does not match the Safety State is 3 - Configuration required.

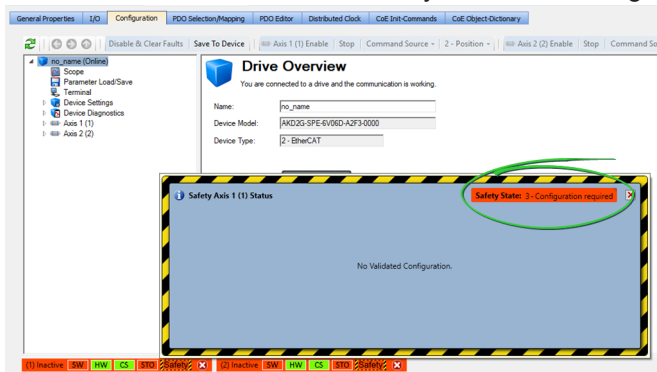

AKD2G module(s) are incorrectly set to use “Workbench Parameters”

The AKD2G has two options for configuring safety parameters.

These are determined by selecting the modules associated with the AKD2G in the KAS-IDE Project Tree.

- If the modules are set for **Workbench Parameters**, the FSoE master cannot set the AKD2G’s safety parameters.
- The **WorkBench Parameter** modules are set by default when the AKD2G is scanned and discovered.
 - The modules must be changed to accept the parameter from the Safety Maser to use FSoEParamsInit.
 - This image shows the appropriate modules for using FSoEParamsInit with AKD2G.

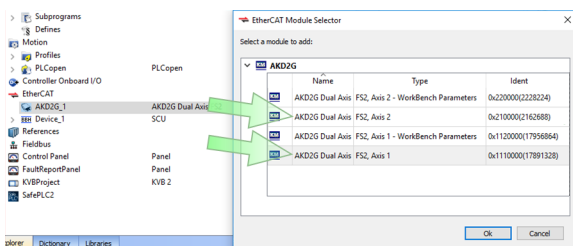

Additionally, the AKD2G profile in the SafePLC2 project should be set to **FSx Axis Y** in order to send the parameters to the AKD2G.

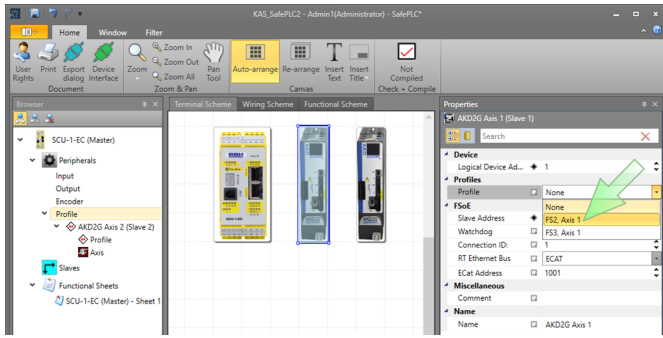

FSoEParamsInit returns with Done = TRUE and Error = FALSE, but no parameters are initialized.

This can occur in two situations:

- If the FSoE safety parameters have been previously configured correctly.
- If the FSoE master has not been configured properly.

FSoEParamsInit only initializes safety parameters if the FSoE master determines there are parameters to set in the safety device(s).

Check the FSoE master configuration using the vendor's software.

Example: With the BBH SCU-1-EC FSoE master, use the SafePLC2 software.

See Also

- "Set Up FSoE Master and an AKD2G with SafeMotion Monitor" (→ p. 582)
- "AKD2G Safety Parametrization Using FSoE with SCU-1-EC and PxMM / PCMM2G" (→ p. 584)
- FSoEParamsInit

23.10 Troubleshooting KAS-IDE and SafePLC2

These are situations you may encounter when you are setting up a KAS project involving SafePLC2.

The ESI file for a Safety device is reported as missing.

EtherCAT devices missing ESI files are identified in the KAS-IDE's EtherCAT **Devices** tab.

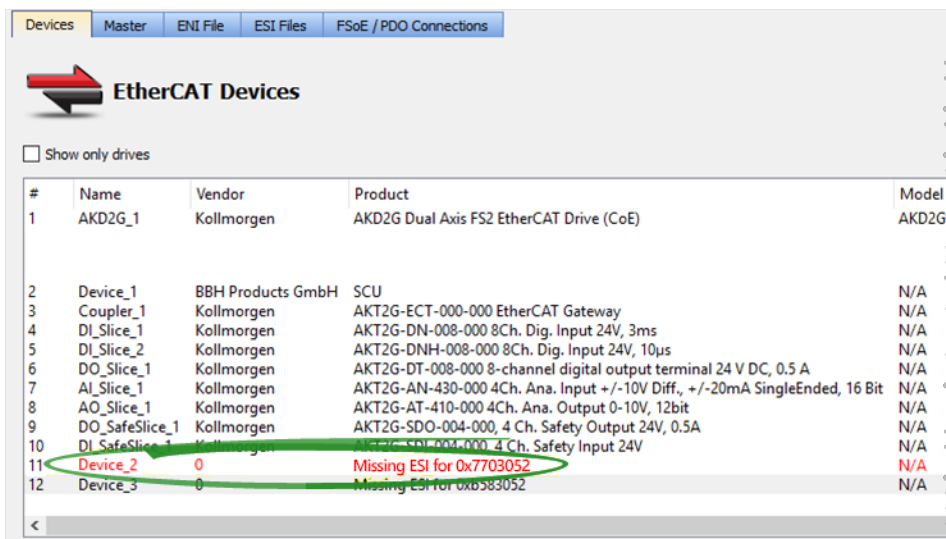

If a Safety device is added to a SafePLC2 project and the KAS-IDE's ESI library does not have a corresponding ESI file for the device, the Local log messages indicates a problem with device creation.

Example:

```

WARNING | Slave creation failed while trying to retrieve slave default
WARNING | Device_2: Slave creation failed while trying to retrieve
slave default Init Commands
WARNING | Device_2: Slave creation failed while trying to get
Distributed Clock(DC) details
WARNING | Slave creation failed while trying to retrieve slave default
PDOs

```

Avoid Error

- Add all Safety devices from the KAS-IDE, including their ESI files, and then launch SafePLC2 from the KAS-IDE project tree.
- SafePLC2 automatically reads the Safety device topology from the KAS-IDE.

Error Correction

- Use the KAS-IDE's EtherCAT-> **ESI Files** tab to add the ESI files for the missing devices.

Topology mismatch with the imported SafePLC2 project

If a SafePLC2 project file is imported into a KAS project, the KAS-IDE checks the incoming Safety project's EtherCAT topology.

Importing the project fails if there is a topology mismatch and the Local logs identifies the mismatched nodes.

Example 1

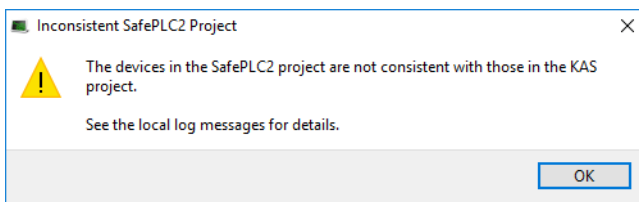

```

ERROR | SafePLC2 topology parser: device #1 - SafeModule #1 -
ConnectsTo element - KAS ID 0 does not match that of the device with
SafePLC2 ID 1 - 4
ERROR | SafePLC2 topology parser: device #1 - SafeModule #2 -
ConnectsTo element - KAS ID 0 does not match that of the device with
SafePLC2 ID 1 - 4
ERROR | SafePLC2 topology parser: device #1 - SafeModule #3 -
ConnectsTo element - KAS ID 8 does not match that of the device with
SafePLC2 ID 3 - 9
ERROR | SafePLC2 topology parser: device #1 - SafeModule #4 -
ConnectsTo element - KAS ID 9 does not match that of the device with
SafePLC2 ID 4 - 8
ERROR | SafePLC2 topology parser: device #2 - the EtherCAT ID of the
device with KAS ID 4 does not match that of "DI_Slice_2"
ERROR | SafePLC2 topology parser: device #3 - SafePLC2 ID (3) does not
match that of "DI_SafeSlice_1" (4)
ERROR | SafePLC2 topology parser: device #3 - the EtherCAT ID of the
device with KAS ID 9 does not match that of "DI_SafeSlice_1"
ERROR | SafePLC2 topology parser: device #4 - SafePLC2 ID (4) does not

```

```
match that of "DO_SafeSlice_1" (3)
ERROR | SafePLC2 topology parser: device #4 - the EtherCAT ID of the
device with KAS ID 8 does not match that of "DO_SafeSlice_1"
```

Example 2

```
ERROR | SafePLC2 topology parser: device #1 - no device with
identifier 11
ERROR | SafePLC2 topology parser: device #2 - no device with
identifier 10
ERROR | SafePLC2 topology parser: device #3 - no device with
identifier 18
ERROR | SafePLC2 topology parser: device #4 - no device with
identifier 19
```

NOTE

Any pre-existing SafePLC2 project inside the KAS project is retained if importing the SafePLC2 project fails.

Error Correction

- Import the SafePLC2 project to the matching .kas project that was originally exported to SafePLC2.

Duplicate FSoE Address

When compiling, the KAS-IDE checks to ensure the FSoE address is unique.

A compiler warning message is generated if the address is not unique.

Example:

```
EtherCAT: Warning: FSoE address 101 is duplicated for these devices:
AKD2G_1, DI_SafeSlice_1, DO_SafeSlice_1
```

Error Correction

1. Change the FSoE address of the devices and set them to be unique to the network.
Refer to the device installation manual for setting the FSoE address.
2. Rescan the EtherCAT network and repeat the steps described in "SafePLC2 Projects" (→ p. 189).

FSoE / PDO Connections do not match the EtherCAT topology.

The compiler generates warnings if the FSoE / PDO Connections defined by the Safety device topology from the SafePLC2 project do not match the EtherCAT Safety device topology defined by the KAS-IDE.

Example:

```
< compiler messages go here! >
```

Avoid Error

- Scan and discover all physical EtherCAT Safety devices from the KAS-IDE before launching SafePLC2 from the KAS-IDE Project tree.
- SafePLC2 automatically reads the Safety device topology from the KAS-IDE.

Error Correction

- Use the KAS-IDE's EtherCAT-> **Scan Devices** to discover and associate the physical Safety devices that are expected by the SafePLC2 project.

24 Appendices: Lists of Manuals, Content, and Support Information

This section provides lists of available manuals, tables, figures, how-to's, etc.

24.1 AKD PDMM and PCMM - File Naming Conventions

AKD PDMM and PCMM use only .IMG files.

24.1.1 File Contents

This .IMG file contains the Operating System (OS) and the KAS Runtime (RT) software.

24.1.2 Usage

The contents of this .IMG file are used to update the AKD PDMM and PCMM from the web server interface.

24.1.3 File Format and Examples

24.1.3.1 AKD PDMM

Controller	File Name Format	Example File Name
AKD PDMM	KAS-PDMM-M- {Model-Code} - {Software-Version} .img	KAS-PDMM-M- K1EC- 4.01.0.91992 .img

24.1.3.2 PCMM

Controller	File Name Format	Example File Name
PCMM	KAS-PCMM-M- {Model-Code} - {Software-Version} .img	KAS-PCMM-M- M2EC- 4.01.0.91992 .img

24.1.4 Model Code

This table shows the specified model's CPU speed and number of cores.

Model Code	CPU Speed	Core
KCEC and MCEC	800 MHz	Single
K1EC and M1EC	1.2 GHz	Single
M2EC	1.2 GHz	Dual

See Also

- "PCMM2G - File Naming Conventions" (→ p. 858)
- "AKD PDMM and PCMM - File Naming Conventions" (→ p. 857)
- "Operating System (OS) License Sources - File Naming Convention" (→ p. 859)
- "Operating System (OS) + KAS Runtime (RT) - File Naming Convention" (→ p. 859)
- "Recovery Operating System (OS) + KAS Runtime (RT) - File Naming Convention" (→ p. 860)
- "KAS Runtime (RT) Only - File Naming Convention" (→ p. 862)
- "Recover Using the Web server" (→ p. 428)

24.2 PCMM2G - File Naming Conventions

There are different KAS files used with the PCMM2G.

Each of these files have unique naming conventions to identify what is included in the file.

24.2.1 PCMM2G Firmware Files

- "Operating System (OS) + KAS Runtime (RT) - File Naming Convention" (→ p. 859)
- "Recovery Operating System (OS) + KAS Runtime (RT) - File Naming Convention" (→ p. 860)
- "KAS Runtime (RT) Only - File Naming Convention" (→ p. 862)
- "Boot Loader - File Naming Convention" (→ p. 861)

24.2.2 PCMM2G Operating Source (OS) and License Files

- "Operating System (OS) Build Sources - File Naming Convention" (→ p. 858)
- "Operating System (OS) License Sources - File Naming Convention" (→ p. 859)

See Also

- "AKD PDMM and PCMM - File Naming Conventions" (→ p. 857)
- "PCMM2G - File Naming Conventions" (→ p. 858)
- "Recover Using the Web server" (→ p. 428)

24.2.3 Operating System (OS) Build Sources - File Naming Convention

24.2.3.1 File Contents

This .ZIP file contains the PCMM2G's OS build source scripts.

24.2.3.2 Usage

The contents of this .ZIP file are used to build the PCMM2G's OS image.

NOTE

See the README.md file in the .ZIP file for build instructions and details about what is included in the OS image.

24.2.3.3 File Format and Example

File Name Format	Example File Name
KAS-PCMM2G-OS-Build-Sources- {OS-Version} .zip	KAS-PCMM2G-OS-Build-Sources- 1.0.0.00289 .zip

See Also

- "AKD PDMM and PCMM - File Naming Conventions" (→ p. 857)
- "PCMM2G - File Naming Conventions" (→ p. 858)

- "Operating System (OS) License Sources - File Naming Convention" (→ p. 859)
- "Operating System (OS) + KAS Runtime (RT) - File Naming Convention" (→ p. 859)
- "Recovery Operating System (OS) + KAS Runtime (RT) - File Naming Convention" (→ p. 860)
- "KAS Runtime (RT) Only - File Naming Convention" (→ p. 862)
- "Recover Using the Web server" (→ p. 428)

24.2.4 Operating System (OS) License Sources - File Naming Convention

24.2.4.1 File Contents

This .ZIP file contains:

- The source code of the PCMM2G's OS, bootloader ([U-Boot](#)), and their software components.
- Kollmorgen's custom modifications to the OS sources.
- Copyright notices, license texts, and disclaimers of warranty.

24.2.4.2 Usage

The contents of this .ZIP file are used to:

- Review the licenses of all the packages used in the PCMM2G OS.
- Identify custom modifications made to these packages.
- The files in this .ZIP are read-only.

24.2.4.3 File Format and Example

File Name Format	Example File Name
KAS-PCMM2G-OS-License-Sources- {OS-Version} .zip	KAS-PCMM2G-OS-License-Sources- 1.0.0.00289 .zip

See Also

- "AKD PDMM and PCMM - File Naming Conventions" (→ p. 857)
- "PCMM2G - File Naming Conventions" (→ p. 858)
- "Operating System (OS) License Sources - File Naming Convention" (→ p. 859)
- "Operating System (OS) + KAS Runtime (RT) - File Naming Convention" (→ p. 859)
- "Recovery Operating System (OS) + KAS Runtime (RT) - File Naming Convention" (→ p. 860)
- "KAS Runtime (RT) Only - File Naming Convention" (→ p. 862)
- "Recover Using the Web server" (→ p. 428)

24.2.5 Operating System (OS) + KAS Runtime (RT) - File Naming Convention

24.2.5.1 File Contents

This .ZIP file contains the PCMM2G's OS and RT files.

24.2.5.2 Usage

The contents of this .ZIP file are used to update the PCMM2G from the web server interface.

24.2.5.3 File Format and Example

File Name Format	Example File Name
KAS-PCMM2G- {Processor/RAM Code} - {Storage-Code} - {OS-Version} - {RT-Version} .zip	KAS-PCMM2G- Cx-08 -OS- 1.0.0.00288 -RT- 4.01.0.91998 .zip

24.2.5.4 Model Code

This table shows the specified model's CPU speed, number of cores, RAM, and storage size.

Processor / RAM / Storage Code	CPU Speed	Core	RAM	Storage
Cx-08	1.5G Hz	Quad	2 / 4 / 8 GB	8GB
Cx-16	1.5G Hz	Quad	2 / 4 / 8 GB	16GB
Cx-32	1.5G Hz	Quad	2 / 4 / 8 GB	32GB

See Also

- "AKD PDMM and PCMM - File Naming Conventions" (→ p. 857)
- "PCMM2G - File Naming Conventions" (→ p. 858)
- "Operating System (OS) + KAS Runtime (RT) - File Naming Convention" (→ p. 859)
- "Operating System (OS) License Sources - File Naming Convention" (→ p. 859)
- "Recovery Operating System (OS) + KAS Runtime (RT) - File Naming Convention" (→ p. 860)
- "KAS Runtime (RT) Only - File Naming Convention" (→ p. 862)
- "Recover Using the Web server" (→ p. 428)

24.2.6 Recovery Operating System (OS) + KAS Runtime (RT) - File Naming Convention

24.2.6.1 File Contents

This .BZ2 file contains the factory default OS and the RT files.

24.2.6.2 Usage

The contents of this .BZ2 file are used to rebuild the PCMM2G when the main flash becomes corrupted. Customers flash this .BZ2 file onto a USB flash drive and use it to recover their broken PCMM2G.

24.2.6.2.1 Reset Changes

The changes which occur during a reset are:

Erased Items

- User data files.
- Any application previously downloaded.
- Retained variables.
- Shared directory settings.
- Log files.

Defaults Restored

- Password for both the web page and SSH login.
 - See "SSH Login to a Controller" (→ p. 400) and "User Authentication" (→ p. 406).
- Controller network configuration.
 - Examples: IP address, Subnet, and Gateway settings.
- Auto-Start option.

PCMM2G Only

- The SSH keys are regenerated.
 - SSH clients logged on during the factory reset are forced to log in again.
 - All Date and Time settings are reset to default (NTP enabled).

24.2.6.3 File Format and Example

File Name Format	Example File Name
KAS-PCMM2G- { Processor/RAM Code } - { Storage Code } - Recovery - { OS-Version } - { RT-Version } .wic.bz2	KAS-PCMM2G- Cx-08-Recovery -OS- 1.0.0.00288 -RT- 4.01.0.91998 .wic.bz2

24.2.6.4 Model Code

This table shows the specified model's CPU speed, number of cores, RAM, and storage size.

Processor / RAM / Storage Code	CPU Speed	Core	RAM	Storage
Cx-08	1.5G Hz	Quad	2 / 4 / 8 GB	8GB
Cx-16	1.5G Hz	Quad	2 / 4 / 8 GB	16GB
Cx-32	1.5G Hz	Quad	2 / 4 / 8 GB	32GB

See Also

- "AKD PDMM and PCMM - File Naming Conventions" (→ p. 857)
- "PCMM2G - File Naming Conventions" (→ p. 858)
- "Recovery Operating System (OS) + KAS Runtime (RT) - File Naming Convention" (→ p. 860)
- "Operating System (OS) License Sources - File Naming Convention" (→ p. 859)
- "Operating System (OS) + KAS Runtime (RT) - File Naming Convention" (→ p. 859)
- "KAS Runtime (RT) Only - File Naming Convention" (→ p. 862)
- "Recover Using the Web server" (→ p. 428)

24.2.7 Boot Loader - File Naming Convention

24.2.7.1 File Contents

This .ZIP file contains the PCMM2G's boot loader file.

The PCMM2G controller uses a Kollmorgen customized version of the [U-Boot](#) boot loader.

See "Copyrights, Licenses, and Trademarks" (→ p. 2) for licensing terms and downloading instructions.

24.2.7.2 Usage

The contents of this .ZIP file are used to update the PCMM2G's boot loader from the Web server interface.

24.2.7.3 File Format and Example

File Name Format	Example File Name
KAS-PCMM2G- {Processor/RAM Code} - {Storage-Code} -bootimage- {Version} .zip	KAS-PCMM2G- Cx-08 -bootimage- 2022.01.01 .zip

24.2.7.4 Model Code

This table shows the specified model's CPU speed, number of cores, RAM, and storage size.

Processor / RAM / Storage Code	CPU Speed	Core	RAM	Storage
Cx-08	1.5G Hz	Quad	2 / 4 / 8 GB	8GB
Cx-16	1.5G Hz	Quad	2 / 4 / 8 GB	16GB
Cx-32	1.5G Hz	Quad	2 / 4 / 8 GB	32GB

See Also

- "AKD PDMM and PCMM - File Naming Conventions" (→ p. 857)
- "PCMM2G - File Naming Conventions" (→ p. 858)
- "Operating System (OS) License Sources - File Naming Convention" (→ p. 859)
- "Operating System (OS) + KAS Runtime (RT) - File Naming Convention" (→ p. 859)
- "Recovery Operating System (OS) + KAS Runtime (RT) - File Naming Convention" (→ p. 860)
- "Recover Using the Web server" (→ p. 428)
- "Upgrade the Controller's Firmware" (→ p. 423)

24.2.8 KAS Runtime (RT) Only - File Naming Convention

This is an unofficial runtime patch file.

24.2.8.1 File Contents

This .ZIP file contains only the RT software.

24.2.8.2 Usage

This file may be sent to individual users when troubleshooting specific issues.

24.2.8.3 File Format and Example

File Name Format	Example File Name
KAS-PCMM2G- {Processor/RAM Code} - {Storage Code} - {RT-Version} .zip	KAS-PCMM2G- Cx-08 -RT- 4.01.0.91998 .zip

24.2.8.4 Model Code

This table shows the specified model's CPU speed, number of cores, RAM, and storage size.

Processor / RAM / Storage Code	CPU Speed	Core	RAM	Storage
Cx-08	1.5G Hz	Quad	2 / 4 / 8 GB	8GB
Cx-16	1.5G Hz	Quad	2 / 4 / 8 GB	16GB
Cx-32	1.5G Hz	Quad	2 / 4 / 8 GB	32GB

See Also

- "AKD PDMM and PCMM - File Naming Conventions" (→ p. 857)
- "PCMM2G - File Naming Conventions" (→ p. 858)
- "Operating System (OS) License Sources - File Naming Convention" (→ p. 859)
- "Operating System (OS) + KAS Runtime (RT) - File Naming Convention" (→ p. 859)
- "Recovery Operating System (OS) + KAS Runtime (RT) - File Naming Convention" (→ p. 860)
- "Recover Using the Web server" (→ p. 428)

25 List of Documentation

This is the available documentation for these components:

- "KAS Documentation" (→ p. 868)
- "KVB Documentation" (→ p. 869)
- "HMI Documentation" (→ p. 865)
- "AKD PDMM and PCMM Documentation" (→ p. 864)
- "AKD, AKD2G, S300, and S700 Documentation" (→ p. 864)
- "IO Documentation" (→ p. 865)
 - "AKT2G-IO (EtherCAT) Terminals" (→ p. 867)
 - "AKT (K-Bus) Terminals" (→ p. 865)



25.1 AKD, AKD2G, S300, and S700 Documentation

Drive Manuals	Description
AKD EtherCAT Manual	Describes the installation, setup, range of functions, and software protocol for the EtherCAT AKD product series.
AKD Installation Manual	<ul style="list-style-type: none"> • Installation manual for AKD and AKD PDMM drives. • Describes the AKD series of digital drives and includes mechanical, electrical, and software installation information needed to safely install AKD.
AKD PDMM Fault Card	<ul style="list-style-type: none"> • Describes the AKD PDMM (including AKD) faults, warnings, error messages, and alarms. • Provides cause and remedy instructions to determine the specifics of the failure and to correct the underlying problem.
AKD PDMM User Manual	<ul style="list-style-type: none"> • Describes the software installation, setup, and operation for the AKD PDMM drive. • Includes basic topics and examples to help set up and use the various features in the drive.
AKD, AKD2G, S700 (in NA) Accessories Manual	Describes the accessories for Kollmorgen digital drive systems and servo drive motors.
AKD2G EtherCAT Manual	Describes the installation, setup, range of functions, and software protocol for the AKD2G product series.
AKD2G Installation Manual	<ul style="list-style-type: none"> • Describes the AKD2G series of digital drives. • Includes mechanical, electrical, software, and functional safety options.
MKD Installation Manual	<ul style="list-style-type: none"> • Installation manual for MKD-N power supply and MKD-C drives. • Describes the MKD devices and includes mechanical, electrical, and software installation information needed to safely install the devices.
S300 Reference Documentation	Kollmorgen website with access to all S300 manuals.
S700 Reference Documentation	Kollmorgen website with access to all S700 manuals.

25.2 AKD PDMM and PCMM Documentation

Product Guides - AKD PDMM / PCMM	
Product Guide	Description
AKD and AKD PDMM Installation Manual	Provides: <ul style="list-style-type: none"> The most important points to install the drive hardware and software. Instructions for basic drive setup and connection to a network.
AKD PDMM Fault Card	Technical data and dimensional drawings of accessories (e.g., cables, brake resistors, and mains supplies).
AKD PDMM Quick Start	All the information needed to safely install and setup an AKD drive.
AKD PDMM User Guide	Provides information on AKD drive parameters, EWV (Embedded Workbench Views), and using the AKD PDMM in the KAS-IDE.
PCMM Installation Guide	Installation and setup of the controller.

25.3 HMI Documentation

HMI Part Number	Description	KVB	Manual
AKI-CDC-MOD-21T-000	Graphical Display 21.5" TFT LCD, Touchscreen	v2.0	
AKI-CDC-MOD-15T-000	Graphical Display 15.4" TFT LCD, Touchscreen	v2.0	
AKI-CDC-MOD-12T-000	Graphical Display 12.1" TFT LCD, Touchscreen	v2.0	
AKI2G-CDA-MOD-07T-000	Graphical Display 5" TFT LCD, Touchscreen	v2.20	
AKI2G-CDA-MOD-05T-000	Graphical Display 7" TFT LCD, Touchscreen	v2.20	
AKI2G-CDB-MOD-12T-000	Graphical Display 12" TFT LCD, Touchscreen	v2.20	
AKI2G-CDB-MOD-07T-000	Graphical Display 7" TFT LCD, Touchscreen	v2.20	

25.4 IO Documentation

- "AKT2G-IO (EtherCAT) Terminals" (→ p. 867)
- "AKT (K-Bus) Terminals" (→ p. 865)

25.4.1 AKT (K-Bus) Terminals

ⓘ IMPORTANT

24-volt power is not passed through AKT-AN-200-000 and AKT-AN-400-000 thermocouple modules. These are the solutions to get 24VDC power to devices that need it (e.g., an AKT_AT-410-000 Output module):

- Place the module requiring 24VDC before the thermocouple module.
- Add a power feed module (AKT-PS-024-000 or AKT-PSF-024-000) after the thermocouple module.

I/O Terminal Part Number	Description	Replaced By
AKT-AN-200-000	2-channel thermocouple input module	AKT2G-AN-240-000

I/O Terminal Part Number	Description	Replaced By
AKT-AN-400-000	4-channel thermocouple input module	AKT2G-AN-400-000
AKT-AN-410-000	<ul style="list-style-type: none"> 4-channel analog input module 0 to 10VDC 	AKT2G-AN-430-000
AKT-AN-420-000	<ul style="list-style-type: none"> 4-channel analog input module 0 to 20mA 	AKT2G-AN-430-000
AKT-AN-810-000	<ul style="list-style-type: none"> 8-channel analog input module 0 to 10VDC 	AKT2G-AN-430-000
AKT-AN-820-000	<ul style="list-style-type: none"> 8-channel analog input module 0 to 20mA 	AKT2G-AN-430-000
AKT-AT-220-000	<ul style="list-style-type: none"> 2-channel analog output module 0 to 20mA 	N/A
AKT-AT-410-000	<ul style="list-style-type: none"> 4-channel analog output module 0 to 10VDC 	N/A
AKT-AT-420-000	<ul style="list-style-type: none"> 4-channel analog output module 0 to 20mA 	N/A
AKT-AT-810-000	<ul style="list-style-type: none"> 8-channel analog output module 0 to 10VDC 	AKT2G-AT-410-000
AKT-AT-820-000	<ul style="list-style-type: none"> 8-channel analog output module 0 to 20mA 	N/A
AKT-DN-004-000	<ul style="list-style-type: none"> 4-channel digital input module 24V_{DC} 3.0ms 	AKT2G-DN-008-000
AKT-DN-008-000	<ul style="list-style-type: none"> 8-channel digital input module 24V_{DC} 3.0ms 	AKT2G-DN-008-000
AKT-DNH-004-000	<ul style="list-style-type: none"> 4-channel digital input module 24V_{DC} 0.2ms 	AKT2G-DNH-008-000
AKT-DNH-008-000	<ul style="list-style-type: none"> 8-channel digital input module 24V_{DC} 0.2ms 	AKT2G-DNH-008-000
AKT-DT-004-000	<ul style="list-style-type: none"> 4-channel digital output module 24V_{DC} 0.5A 	AKT2G-DT-008-000
AKT-DT-008-000	<ul style="list-style-type: none"> 8-channel digital output module 24V_{DC} 0.5A 	AKT2G-DT-008-000
AKT-DT-2RT-000	<ul style="list-style-type: none"> 2-channel Relay Output Module 230VAC 2.0A Rel.2NO Pot.-Free 	N/A
AKT-ECT-000-000	EtherCAT Bus Coupler	AKT2G-ECT-000-000
AKT-EM-000-000	Standard-Bus End Terminal	AKT2G-EM-000-000
AKT-IM-000-000	Isolation / Separation Terminal	N/A



I/O Terminal Part Number	Description	Replaced By
AKT-PS-024-000	Power Supply, 24V _{DC}	AKT2G-PSF-024-000
AKT-PSF-024-000	Fused Power Supply with diagnostics, 24V _{DC}	AKT2G-PSF-024-000
AKT-SM-L15-000	<ul style="list-style-type: none"> Stepper motor terminal 24V_{DC} 1.5A 	AKT2G-SM-L15-000
AKT-SM-L50-000	<ul style="list-style-type: none"> Stepper motor terminal 50V_{DC} 5A 	AKT2G-SM-L50-000





25.4.2 AKT2G-IO (EtherCAT) Terminals

I/O Terminal Part Number	I/O Terminal Description
AKT2G-AC-FAN-001	Fan cartridge for EtherCAT and Bus Terminals.
AKT2G-AN-240-000	<ul style="list-style-type: none"> 2-channel input terminal PT100 (RTD) for resistance sensors. 16-bit, 2-, 3-wire system.
AKT2G-AN-400-000	<ul style="list-style-type: none"> 4-channel thermocouple input terminal. Preset to type K, with wire breakage detection. 16-bit
AKT2G-AN-430-000	<ul style="list-style-type: none"> 4-channel analog input. Parameter capable -10/0 to 10V -20/0/+4 to +20mA 16-bit
AKT2G-AT-410-000	<ul style="list-style-type: none"> 4-channel analog output terminal. 0 to 10V 1-wire system 12-bit
AKT2G-AT-425-000	<ul style="list-style-type: none"> 4-channel analog output terminal. -10V to +10V 4 x 2-wire system 12-bit
AKT2G-BRC-000-000	Brake Chopper Terminal
AKT2G-DN-002-000	<ul style="list-style-type: none"> Up/down counter 24V_{DC} 100 kHz 32-bit counter depth
AKT2G-DN-008-000	<ul style="list-style-type: none"> 8-channel digital input terminal 24V_{DC}. Filter 3.0ms 1-wire system
AKT2G-DNH-008-000	<ul style="list-style-type: none"> 8-channel digital input terminal 24V_{DC}. Filter 10μs 1-wire system
AKT2G]DT-008-000	<ul style="list-style-type: none"> 8-channel digital output terminal 24V_{DC} 0.5A 1-wire system
AKT2G-ECT-000-000	EtherCAT Coupler for E-bus terminals

I/O Terminal Part Number	I/O Terminal Description
AKT2G-EM-000-000	<ul style="list-style-type: none"> • Bus end cover for E-bus terminals • Cover for power and E-bus contacts, gray
AKT2G-ENC-180-000	<ul style="list-style-type: none"> • 1-channel incremental encoder interface • 32-bit
AKT2G-ENC-190-000	<ul style="list-style-type: none"> • Incremental encoder interface with differential input • 16-bit / 32-bit
AKT2G-PSF-024-000	<ul style="list-style-type: none"> • Power supply terminal with fuse • 24V_{DC}
AKT2G-SDI-004-000	<ul style="list-style-type: none"> • 4-channel digital input terminal 24V_{DC}. • Safety
AKT2G-SDO-004-000	<ul style="list-style-type: none"> • 4-channel digital input terminal 24V_{DC}. • Safety • 0.5A
AKT2G-SM-L15-000	<ul style="list-style-type: none"> • Stepper motor terminal • 24V_{DC} • 1.5A • Vector control
AKT2G-SM-L50-000	<ul style="list-style-type: none"> • Stepper motor terminal • 50V_{DC} • 5A • Vector control

25.5 KAS Documentation

Document Title	Description	Download
Release Notes	<p>The KAS Release Notes contain a summary of:</p> <ul style="list-style-type: none"> • New features, fixed and known limitations, workarounds • Information on all hardware and software components that have been updated, changed, or added in the release. 	
Getting Started	<p>Contains these main steps to get the KAS system up and running.</p> <ul style="list-style-type: none"> • Hardware (HW) Installation (Connection and Wiring): Wiring and hardware details, connectors, system diagrams. • HW Configuration: Basic configuration and settings needed to start the HW components (e.g., HMI, Industrial PC, Fieldbus, I/O). • Software (SW) Installation: KAS software setup. 	

Document Title	Description	Download
30 Minutes to Motion	<p>Contains the main topics to get started quickly with KAS-IDE. The objective is to familiarize you with the basic principles and the way the program works by creating a simple motion application project. This document contains information about:</p> <ul style="list-style-type: none"> • Key Features <ul style="list-style-type: none"> • See the Key Features in KAS. • Explore the Workspace <ul style="list-style-type: none"> • See "Describing the KAS Graphical User Interface" (→ p. 70). • Build a Motion Project <ul style="list-style-type: none"> • Almost every task performed in KAS falls under one of these basic steps (which may not always be completed in this order): <ul style="list-style-type: none"> • Start Projects - Create a project from scratch or modify an existing project. See Create a Project. • Add Components - Add necessary elements to build the project and control the motion part of the system. This includes: "Create Variables" (→ p. 303), "Adding Motion" (→ p. 158), and "Programs: Structure and Syntax" (→ p. 269). • Build Output - Select a device and generate the application to deliver to users. See "Run the Project" (→ p. 222). • Run Output - Make the output accessible to end-users. 	
KAS-IDE User Manual	Contains content to help with KAS-IDE except the topics included in the Reference Manuals.	
Reference Manual - PLC Library	Contains Technical References on PLC Programming Languages and Library.	
Reference Manual - Motion Library	Contains Technical References on Motion Library for Pipe Network and PLCopen.	

25.6 KVB Documentation

KVB Manuals	Description
Kollmorgen Visualization Builder™ Quick Start Guide	<p>The Quick Start covers these important points to:</p> <ul style="list-style-type: none"> • Install and use Kollmorgen Visualization Builder. • Configure HMI Panels and PC operated control applications.
Kollmorgen Visualization Builder™ User Manual	Contains all the content to help with Kollmorgen Visualization Builder.

26 List of How-Tos

- "Advanced Motion How-Tos" (→ p. 870)
- "EtherCAT Fieldbus How-Tos" (→ p. 870)
- "Hardware How-Tos" (→ p. 870)
- "PLC Code How-Tos" (→ p. 870)
- "Run the Application How-Tos" (→ p. 870)

26.1 Advanced Motion How-Tos

- "How do I implement Torque Feed-forward?" (→ p. 831)
- Use "Fast Inputs with Pipe Network Motion" (→ p. 552)
- Use "Fast Inputs with PLCopen Motion" (→ p. 553)
- "Digitizing Axis - PLCopen Setup" (→ p. 549)

26.2 EtherCAT Fieldbus How-Tos

- "Create a Digitizing Axis" (→ p. 545)

26.3 Hardware How-Tos

- "Verify the NVRAM Space" (→ p. 691)
- "FAQs" (→ p. 823)
- "Download the KVB Panel" (→ p. 464)

26.4 PLC Code How-Tos

- "How to change a Pipe Network link?" (→ p. 159)
- Control an SFC Child Program
- "Create a PLCopen Axis" (→ p. 166)
- "Draw SFC Divergences" (→ p. 295)
- "Read the Output of a MC Function Block in ST" (→ p. 302)
- "How can variables be arranged and/or sorted?" (→ p. 89)
- Start and Stop a PLC Application using a Command Line Tool
- "How to toggle the connection to make it negative?" (→ p. 275)
- "Location Details" (→ p. 110)

26.5 Run the Application How-Tos

- "Activate an Online Change" (→ p. 557)
- "Change the Priority Between PLC Programs" (→ p. 822)
- "Log Messages Settings" (→ p. 104)
- "How Do I Export the Oscilloscope Data?" (→ p. 497)
- "Plugging Probes, Mapping Variables" (→ p. 492)
- "Plug Motion Variables" (→ p. 236)
- "Plug PLC Variables" (→ p. 238)
- Set "Breakpoints" (→ p. 232)
- Specify the Duration of a Cycle using the "EtherCAT Master Settings tab" (→ p. 327)

27 Licenses

27.1 AjaxFileUpload — MPL License

See www.mozilla.org/MPL/2.0/ for the Mozilla Public License.

27.2 Apache log4net — Apache License

Apache License
Version 2.0, January 2004
<http://www.apache.org/licenses/>

TERMS AND CONDITIONS FOR USE, REPRODUCTION, AND DISTRIBUTION

1. Definitions.

"License" shall mean the terms and conditions for use, reproduction, and distribution as defined by Sections 1 through 9 of this document.

"Licensor" shall mean the copyright owner or entity authorized by the copyright owner that is granting the License.

"Legal Entity" shall mean the union of the acting entity and all other entities that control, are controlled by, or are under common control with that entity. For the purposes of this definition, "control" means (i) the power, direct or indirect, to cause the direction or management of such entity, whether by contract or otherwise, or (ii) ownership of fifty percent (50%) or more of the outstanding shares, or (iii) beneficial ownership of such entity.

"You" (or "Your") shall mean an individual or Legal Entity exercising permissions granted by this License.

"Source" form shall mean the preferred form for making modifications, including but not limited to software source code, documentation source, and configuration files.

"Object" form shall mean any form resulting from mechanical transformation or translation of a Source form, including but not limited to compiled object code, generated documentation, and conversions to other media types.

"Work" shall mean the work of authorship, whether in Source or Object form, made available under the License, as indicated by a copyright notice that is included in or attached to the work (an example is provided in the Appendix below).

"Derivative Works" shall mean any work, whether in Source or Object form, that is based on (or derived from) the Work and for which the editorial

revisions, annotations, elaborations, or other modifications represent, as a whole, an original work of authorship. For the purposes of this License, Derivative Works shall not include works that remain separable from, or merely link (or bind by name) to the interfaces of, the Work and Derivative Works thereof.

"Contribution" shall mean any work of authorship, including the original version of the Work and any modifications or additions to that Work or Derivative Works thereof, that is intentionally submitted to Licensor for inclusion in the Work by the copyright owner or by an individual or Legal Entity authorized to submit on behalf of the copyright owner. For the purposes of this definition, "submitted" means any form of electronic, verbal, or written communication sent to the Licensor or its representatives, including but not limited to communication on electronic mailing lists, source code control systems, and issue tracking systems that are managed by, or on behalf of, the Licensor for the purpose of discussing and improving the Work, but excluding communication that is conspicuously marked or otherwise designated in writing by the copyright owner as "Not a Contribution."

"Contributor" shall mean Licensor and any individual or Legal Entity on behalf of whom a Contribution has been received by Licensor and subsequently incorporated within the Work.

2. Grant of Copyright License. Subject to the terms and conditions of this License, each Contributor hereby grants to You a perpetual, worldwide, non-exclusive, no-charge, royalty-free, irrevocable copyright license to reproduce, prepare Derivative Works of, publicly display, publicly perform, sublicense, and distribute the Work and such Derivative Works in Source or Object form.

3. Grant of Patent License. Subject to the terms and conditions of this License, each Contributor hereby grants to You a perpetual, worldwide, non-exclusive, no-charge, royalty-free, irrevocable (except as stated in this section) patent license to make, have made, use, offer to sell, sell, import, and otherwise transfer the Work, where such license applies only to those patent claims licensable by such Contributor that are necessarily infringed by their Contribution(s) alone or by combination of their Contribution(s) with the Work to which such Contribution(s) was submitted. If You institute patent litigation against any entity (including a cross-claim or counterclaim in a lawsuit) alleging that the Work or a Contribution incorporated within the Work constitutes direct or contributory patent infringement, then any patent licenses granted to You under this License for that Work shall terminate as of the date such litigation is filed.

4. Redistribution. You may reproduce and distribute copies of the Work or Derivative Works thereof in any medium, with or without modifications, and in Source or Object form, provided that You meet the following conditions:

(a) You must give any other recipients of the Work or Derivative Works

a copy of this License; and

(b) You must cause any modified files to carry prominent notices stating that You changed the files; and

(c) You must retain, in the Source form of any Derivative Works that You distribute, all copyright, patent, trademark, and attribution notices from the Source form of the Work, excluding those notices that do not pertain to any part of the Derivative Works; and

(d) If the Work includes a "NOTICE" text file as part of its distribution, then any Derivative Works that You distribute must include a readable copy of the attribution notices contained within such NOTICE file, excluding those notices that do not pertain to any part of the Derivative Works, in at least one of the following places: within a NOTICE text file distributed as part of the Derivative Works; within the Source form or documentation, if provided along with the Derivative Works; or, within a display generated by the Derivative Works, if and wherever such third-party notices normally appear. The contents of the NOTICE file are for informational purposes only and do not modify the License. You may add Your own attribution notices within Derivative Works that You distribute, alongside or as an addendum to the NOTICE text from the Work, provided that such additional attribution notices cannot be construed as modifying the License.

You may add Your own copyright statement to Your modifications and may provide additional or different license terms and conditions for use, reproduction, or distribution of Your modifications, or for any such Derivative Works as a whole, provided Your use, reproduction, and distribution of the Work otherwise complies with the conditions stated in this License.

5. Submission of Contributions. Unless You explicitly state otherwise, any Contribution intentionally submitted for inclusion in the Work by You to the Licensor shall be under the terms and conditions of this License, without any additional terms or conditions. Notwithstanding the above, nothing herein shall supersede or modify the terms of any separate license agreement you may have executed with Licensor regarding such Contributions.

6. Trademarks. This License does not grant permission to use the trade names, trademarks, service marks, or product names of the Licensor, except as required for reasonable and customary use in describing the origin of the Work and reproducing the content of the NOTICE file.

7. Disclaimer of Warranty. Unless required by applicable law or agreed to in writing, Licensor provides the Work (and each Contributor provides its Contributions) on an "AS IS" BASIS, WITHOUT WARRANTIES OR CONDITIONS OF ANY KIND, either express or implied, including, without limitation, any warranties or conditions of TITLE, NON-INFRINGEMENT, MERCHANTABILITY, or

FITNESS FOR A PARTICULAR PURPOSE. You are solely responsible for determining the appropriateness of using or redistributing the Work and assume any risks associated with Your exercise of permissions under this License.

8. Limitation of Liability. In no event and under no legal theory, whether in tort (including negligence), contract, or otherwise, unless required by applicable law (such as deliberate and grossly negligent acts) or agreed to in writing, shall any Contributor be liable to You for damages, including any direct, indirect, special, incidental, or consequential damages of any character arising as a result of this License or out of the use or inability to use the Work (including but not limited to damages for loss of goodwill, work stoppage, computer failure or malfunction, or any and all other commercial damages or losses), even if such Contributor has been advised of the possibility of such damages.

9. Accepting Warranty or Additional Liability. While redistributing the Work or Derivative Works thereof, You may choose to offer, and charge a fee for, acceptance of support, warranty, indemnity, or other liability obligations and/or rights consistent with this License. However, in accepting such obligations, You may act only on Your own behalf and on Your sole responsibility, not on behalf of any other Contributor, and only if You agree to indemnify, defend, and hold each Contributor harmless for any liability incurred by, or claims asserted against, such Contributor by reason of your accepting any such warranty or additional liability.

END OF TERMS AND CONDITIONS

APPENDIX: How to apply the Apache License to your work.

To apply the Apache License to your work, attach the following boilerplate notice, with the fields enclosed by brackets "[]" replaced with your own identifying information. (Don't include the brackets!) The text should be enclosed in the appropriate comment syntax for the file format. We also recommend that a file or class name and description of purpose be included on the same "printed page" as the copyright notice for easier identification within third-party archives.

Copyright [yyyy] [name of copyright owner]

Licensed under the Apache License, Version 2.0 (the "License"); you may not use this file except in compliance with the License. You may obtain a copy of the License at

<http://www.apache.org/licenses/LICENSE-2.0>

Unless required by applicable law or agreed to in writing, software distributed under the License is distributed on an "AS IS" BASIS, WITHOUT WARRANTIES OR CONDITIONS OF ANY KIND, either express or implied. See the License for the specific language governing permissions and limitations under

the License.

27.3 bsdtar and libarchive 2 — BSD License

bsdtar.exe and libarchive2.dll for Windows

Copyright (c) 2003-2006 Tim Kientzle
All rights reserved.

Redistribution and use in source and binary forms, with or without modification, are permitted provided that the following conditions are met:

1. Redistributions of source code must retain the above copyright notice, this list of conditions and the following disclaimer in this position and unchanged.
2. Redistributions in binary form must reproduce the above copyright notice, this list of conditions and the following disclaimer in the documentation and/or other materials provided with the distribution.

THIS SOFTWARE IS PROVIDED BY THE AUTHOR(S) ``AS IS'' AND ANY EXPRESS OR IMPLIED WARRANTIES, INCLUDING, BUT NOT LIMITED TO, THE IMPLIED WARRANTIES OF MERCHANTABILITY AND FITNESS FOR A PARTICULAR PURPOSE ARE DISCLAIMED. IN NO EVENT SHALL THE AUTHOR(S) BE LIABLE FOR ANY DIRECT, INDIRECT, INCIDENTAL, SPECIAL, EXEMPLARY, OR CONSEQUENTIAL DAMAGES (INCLUDING, BUT NOT LIMITED TO, PROCUREMENT OF SUBSTITUTE GOODS OR SERVICES; LOSS OF USE, DATA, OR PROFITS; OR BUSINESS INTERRUPTION) HOWEVER CAUSED AND ON ANY THEORY OF LIABILITY, WHETHER IN CONTRACT, STRICT LIABILITY, OR TORT (INCLUDING NEGLIGENCE OR OTHERWISE) ARISING IN ANY WAY OUT OF THE USE OF THIS SOFTWARE, EVEN IF ADVISED OF THE POSSIBILITY OF SUCH DAMAGE.

27.4 bzip2.dll — BSD License

bzip2.dll

Copyright © 1996-2007 Julian Seward

This program, bzip2, the associated library libbzip2, and all documentation, are copyright © 1996-2007 Julian Seward. All rights reserved.

Redistribution and use in source and binary forms, with or without modification, are permitted provided that the following conditions are met:

- Redistributions of source code must retain the above copyright notice, this list of conditions and the following disclaimer.
- The origin of this software must not be misrepresented; you must not claim that you wrote the original software. If you use this software in a product, an acknowledgment in the product documentation would be appreciated but is not required.
- Altered source versions must be plainly marked as such, and must not be misrepresented as being the original software.
- The name of the author may not be used to endorse or promote products

derived from this software without specific prior written permission.

THIS SOFTWARE IS PROVIDED BY THE AUTHOR "AS IS" AND ANY EXPRESS OR IMPLIED WARRANTIES, INCLUDING, BUT NOT LIMITED TO, THE IMPLIED WARRANTIES OF MERCHANTABILITY AND FITNESS FOR A PARTICULAR PURPOSE ARE DISCLAIMED. IN NO EVENT SHALL THE AUTHOR BE LIABLE FOR ANY DIRECT, INDIRECT, INCIDENTAL, SPECIAL, EXEMPLARY, OR CONSEQUENTIAL DAMAGES (INCLUDING, BUT NOT LIMITED TO, PROCUREMENT OF SUBSTITUTE GOODS OR SERVICES; LOSS OF USE, DATA, OR PROFITS; OR BUSINESS INTERRUPTION) HOWEVER CAUSED AND ON ANY THEORY OF LIABILITY, WHETHER IN CONTRACT, STRICT LIABILITY, OR TORT (INCLUDING NEGLIGENCE OR OTHERWISE) ARISING IN ANY WAY OUT OF THE USE OF THIS SOFTWARE, EVEN IF ADVISED OF THE POSSIBILITY OF SUCH DAMAGE.

27.5 DockPanel Suite — MIT License

DockPanel

The MIT License

Copyright (c) 2007 Weifen Luo (email: weifenluo@yahoo.com)

Permission is hereby granted, free of charge, to any person obtaining a copy of this software and associated documentation files (the "Software"), to deal in the Software without restriction, including without limitation the rights to use, copy, modify, merge, publish, distribute, sublicense, and/or sell copies of the Software, and to permit persons to whom the Software is furnished to do so, subject to the following conditions:

The above copyright notice and this permission notice shall be included in all copies or substantial portions of the Software.

THE SOFTWARE IS PROVIDED "AS IS", WITHOUT WARRANTY OF ANY KIND, EXPRESS OR IMPLIED, INCLUDING BUT NOT LIMITED TO THE WARRANTIES OF MERCHANTABILITY, FITNESS FOR A PARTICULAR PURPOSE AND NONINFRINGEMENT. IN NO EVENT SHALL THE AUTHORS OR COPYRIGHT HOLDERS BE LIABLE FOR ANY CLAIM, DAMAGES OR OTHER LIABILITY, WHETHER IN AN ACTION OF CONTRACT, TORT OR OTHERWISE, ARISING FROM, OUT OF OR IN CONNECTION WITH THE SOFTWARE OR THE USE OR OTHER DEALINGS IN THE SOFTWARE.

27.6 FileHelpers

FileHelpers

<http://www.filehelpers.com> - SF Home:
<http://sourceforge.net/projects/filehelpers>

The FileHelpers are an easy to use library to import/export data from fixed length or delimited files.

If you want to start using the library go directly to the Quick Start Guide in the CHM.

Who needs the File Helpers Library ?

In almost every project there is a need to read/write data from/to a file of a specified format.

For example for log parsing, data warehouse and OLAP applications, communication between systems, file format transformations (for example from a fixed length to a CSV file).

This library aims to provide an easy and reliable way to accomplish this task.

History

Check The docs for the History (is hard to mantain two copies =)

Licence

FileHelpers Library is © Copyright 2005-2006 to Marcos Meli but it's source code and the binaries are free for commercial and non commercial use.

LGPL license description is available here:
<http://www.opensource.org/licenses/lgpl-license.php>

Contact and Ideas

If you find that there is a feature that I must include, or you have a new idea (for the API, Source Code or Examples), only let me know, sending an e-mail to marcos@filehelpers.com or entering the FileHelpers Forums at

<http://www.filehelpers.com/forums/>

```
-----
Full Sources and Updates
-----
```

If you want to help in the development of the library please go to

```
http://sourceforge.net/project/showfiles.php?group_id=152382&package_
id=169468
```

and download the AllInOne DevPack with the binaries of NUnit, NAnt and NDoc.

27.7 jQuery Cookies

Copyright (c) 2005 - 2013 James Auldridge

Permission is hereby granted, free of charge, to any person obtaining a copy of this software and associated documentation files (the "Software"), to deal in the Software without restriction, including without limitation the rights to use, copy, modify, merge, publish, distribute, sublicense, and/or sell copies of the Software, and to permit persons to whom the Software is furnished to do so, subject to the following conditions:

The above copyright notice and this permission notice shall be included in all copies or substantial portions of the Software.

THE SOFTWARE IS PROVIDED "AS IS", WITHOUT WARRANTY OF ANY KIND, EXPRESS OR IMPLIED, INCLUDING BUT NOT LIMITED TO THE WARRANTIES OF MERCHANTABILITY, FITNESS FOR A PARTICULAR PURPOSE AND NONINFRINGEMENT. IN NO EVENT SHALL THE AUTHORS OR COPYRIGHT HOLDERS BE LIABLE FOR ANY CLAIM, DAMAGES OR OTHER LIABILITY, WHETHER IN AN ACTION OF CONTRACT, TORT OR OTHERWISE, ARISING FROM, OUT OF OR IN CONNECTION WITH THE SOFTWARE OR THE USE OR OTHER DEALINGS IN THE SOFTWARE.

27.8 jQuery File Tree — MIT License

JQueryFileTree

Copyright (c) 2008 A Beautiful Site, LLC.

Permission is hereby granted, free of charge, to any person obtaining a copy of this software and associated documentation files (the "Software"), to deal in the Software without restriction, including without limitation the rights to use, copy, modify, merge, publish, distribute, sublicense, and/or sell copies of the Software, and to permit persons to whom the Software is furnished to do so, subject to the following conditions:

The above copyright notice and this permission notice shall be included in

all copies or substantial portions of the Software.

THE SOFTWARE IS PROVIDED "AS IS", WITHOUT WARRANTY OF ANY KIND, EXPRESS OR IMPLIED, INCLUDING BUT NOT LIMITED TO THE WARRANTIES OF MERCHANTABILITY, FITNESS FOR A PARTICULAR PURPOSE AND NONINFRINGEMENT. IN NO EVENT SHALL THE AUTHORS OR COPYRIGHT HOLDERS BE LIABLE FOR ANY CLAIM, DAMAGES OR OTHER LIABILITY, WHETHER IN AN ACTION OF CONTRACT, TORT OR OTHERWISE, ARISING FROM, OUT OF OR IN CONNECTION WITH THE SOFTWARE OR THE USE OR OTHER DEALINGS IN THE SOFTWARE.

27.9 JavaScript Graphics Library — GNU Lesser General Public License

GNU GENERAL PUBLIC LICENSE

Version 3, 29 June 2007

Copyright (C) 2007 Free Software Foundation, Inc. <<http://fsf.org/>>
Everyone is permitted to copy and distribute verbatim copies of this license document, but changing it is not allowed.

Preamble

The GNU General Public License is a free, copyleft license for software and other kinds of works.

The licenses for most software and other practical works are designed to take away your freedom to share and change the works. By contrast, the GNU General Public License is intended to guarantee your freedom to share and change all versions of a program--to make sure it remains free software for all its users. We, the Free Software Foundation, use the GNU General Public License for most of our software; it applies also to any other work released this way by its authors. You can apply it to your programs, too.

When we speak of free software, we are referring to freedom, not price. Our General Public Licenses are designed to make sure that you have the freedom to distribute copies of free software (and charge for them if you wish), that you receive source code or can get it if you want it, that you can change the software or use pieces of it in new free programs, and that you know you can do these things.

To protect your rights, we need to prevent others from denying you these rights or asking you to surrender the rights. Therefore, you have certain responsibilities if you distribute copies of the software, or if you modify it: responsibilities to respect the freedom of others.

For example, if you distribute copies of such a program, whether gratis or for a fee, you must pass on to the recipients the same freedoms that you received. You must make sure that they, too, receive or can get the source code. And you must show them these terms so they know their rights.

Developers that use the GNU GPL protect your rights with two steps: (1) assert copyright on the software, and (2) offer you this License giving you legal permission to copy, distribute and/or modify it.

For the developers' and authors' protection, the GPL clearly explains that there is no warranty for this free software. For both users' and authors' sake, the GPL requires that modified versions be marked as changed, so that their problems will not be attributed erroneously to authors of previous versions.

Some devices are designed to deny users access to install or run modified versions of the software inside them, although the manufacturer can do so. This is fundamentally incompatible with the aim of protecting users' freedom to change the software. The systematic pattern of such abuse occurs in the area of products for individuals to use, which is precisely where it is most unacceptable. Therefore, we have designed this version of the GPL to prohibit the practice for those products. If such problems arise substantially in other domains, we stand ready to extend this provision to those domains in future versions of the GPL, as needed to protect the freedom of users.

Finally, every program is threatened constantly by software patents. States should not allow patents to restrict development and use of software on general-purpose computers, but in those that do, we wish to avoid the special danger that patents applied to a free program could make it effectively proprietary. To prevent this, the GPL assures that patents cannot be used to render the program non-free.

The precise terms and conditions for copying, distribution and modification follow.

TERMS AND CONDITIONS

0. Definitions.

"This License" refers to version 3 of the GNU General Public License.

"Copyright" also means copyright-like laws that apply to other kinds of works, such as semiconductor masks.

"The Program" refers to any copyrightable work licensed under this License. Each licensee is addressed as "you". "Licensees" and "recipients" may be individuals or organizations.

To "modify" a work means to copy from or adapt all or part of the work in a fashion requiring copyright permission, other than the making of an exact copy. The resulting work is called a "modified version" of the earlier work or a work "based on" the earlier work.

A "covered work" means either the unmodified Program or a work based on the

Program.

To "propagate" a work means to do anything with it that, without permission, would make you directly or secondarily liable for infringement under applicable copyright law, except executing it on a computer or modifying a private copy. Propagation includes copying, distribution (with or without modification), making available to the public, and in some countries other activities as well.

To "convey" a work means any kind of propagation that enables other parties to make or receive copies. Mere interaction with a user through a computer network, with no transfer of a copy, is not conveying.

An interactive user interface displays "Appropriate Legal Notices" to the extent that it includes a convenient and prominently visible feature that (1) displays an appropriate copyright notice, and (2) tells the user that there is no warranty for the work (except to the extent that warranties are provided), that licensees may convey the work under this License, and how to view a copy of this License. If the interface presents a list of user commands or options, such as a menu, a prominent item in the list meets this criterion.

1. Source Code.

The "source code" for a work means the preferred form of the work for making modifications to it. "Object code" means any non-source form of a work.

A "Standard Interface" means an interface that either is an official standard defined by a recognized standards body, or, in the case of interfaces specified for a particular programming language, one that is widely used among developers working in that language.

The "System Libraries" of an executable work include anything, other than the work as a whole, that (a) is included in the normal form of packaging a Major Component, but which is not part of that Major Component, and (b) serves only to enable use of the work with that Major Component, or to implement a Standard Interface for which an implementation is available to the public in source code form. A "Major Component", in this context, means a major essential component (kernel, window system, and so on) of the specific operating system (if any) on which the executable work runs, or a compiler used to produce the work, or an object code interpreter used to run it.

The "Corresponding Source" for a work in object code form means all the source code needed to generate, install, and (for an executable work) run the object code and to modify the work, including scripts to control those activities. However, it does not include the work's System Libraries, or general-purpose tools or generally available free programs which are used unmodified in performing those activities but which are not part of the work.

For example, Corresponding Source includes interface definition files associated with source files for the work, and the source code for shared libraries and dynamically linked subprograms that the work is specifically designed to require, such as by intimate data communication or control flow between those subprograms and other parts of the work.

The Corresponding Source need not include anything that users can regenerate automatically from other parts of the Corresponding Source.

The Corresponding Source for a work in source code form is that same work.

2. Basic Permissions.

All rights granted under this License are granted for the term of copyright on the Program, and are irrevocable provided the stated conditions are met. This License explicitly affirms your unlimited permission to run the unmodified Program. The output from running a covered work is covered by this License only if the output, given its content, constitutes a covered work. This License acknowledges your rights of fair use or other equivalent, as provided by copyright law.

You may make, run and propagate covered works that you do not convey, without conditions so long as your license otherwise remains in force. You may convey covered works to others for the sole purpose of having them make modifications exclusively for you, or provide you with facilities for running those works, provided that you comply with the terms of this License in conveying all material for which you do not control copyright. Those thus making or running the covered works for you must do so exclusively on your behalf, under your direction and control, on terms that prohibit them from making any copies of your copyrighted material outside their relationship with you.

Conveying under any other circumstances is permitted solely under the conditions stated below. Sublicensing is not allowed; section 10 makes it unnecessary.

3. Protecting Users' Legal Rights From Anti-Circumvention Law.

No covered work shall be deemed part of an effective technological measure under any applicable law fulfilling obligations under article 11 of the WIPO copyright treaty adopted on 20 December 1996, or similar laws prohibiting or restricting circumvention of such measures.

When you convey a covered work, you waive any legal power to forbid circumvention of technological measures to the extent such circumvention is effected by exercising rights under this License with respect to the covered work, and you disclaim any intention to limit operation or modification of the work as a means of enforcing, against the work's users, your or third parties' legal rights to forbid circumvention of technological measures.

4. Conveying Verbatim Copies.

You may convey verbatim copies of the Program's source code as you receive it, in any medium, provided that you conspicuously and appropriately publish on each copy an appropriate copyright notice; keep intact all notices stating that this License and any non-permissive terms added in accord with section 7 apply to the code; keep intact all notices of the absence of any warranty; and give all recipients a copy of this License along with the Program.

You may charge any price or no price for each copy that you convey, and you may offer support or warranty protection for a fee.

5. Conveying Modified Source Versions.

You may convey a work based on the Program, or the modifications to produce it from the Program, in the form of source code under the terms of section 4, provided that you also meet all of these conditions:

a) The work must carry prominent notices stating that you modified it, and giving a relevant date.

b) The work must carry prominent notices stating that it is released under this License and any conditions added under section 7. This requirement modifies the requirement in section 4 to "keep intact all notices".

c) You must license the entire work, as a whole, under this License to anyone who comes into possession of a copy. This License will therefore apply, along with any applicable section 7 additional terms, to the whole of the work, and all its parts, regardless of how they are packaged. This License gives no permission to license the work in any other way, but it does not invalidate such permission if you have separately received it.

d) If the work has interactive user interfaces, each must display Appropriate Legal Notices; however, if the Program has interactive interfaces that do not display Appropriate Legal Notices, your work need not make them do so.

A compilation of a covered work with other separate and independent works, which are not by their nature extensions of the covered work, and which are not combined with it such as to form a larger program, in or on a volume of a storage or distribution medium, is called an "aggregate" if the compilation and its resulting copyright are not used to limit the access or legal rights of the compilation's users beyond what the individual works permit. Inclusion of a covered work in an aggregate does not cause this License to apply to the other parts of the aggregate.

6. Conveying Non-Source Forms.

You may convey a covered work in object code form under the terms of sections 4 and 5, provided that you also convey the machine-readable Corresponding Source under the terms of this License, in one of these ways:

a) Convey the object code in, or embodied in, a physical product (including a physical distribution medium), accompanied by the Corresponding Source fixed on a durable physical medium customarily used for software interchange.

b) Convey the object code in, or embodied in, a physical product (including a physical distribution medium), accompanied by a written offer, valid for at least three years and valid for as long as you offer spare parts or customer support for that product model, to give anyone who possesses the object code either (1) a copy of the Corresponding Source for all the software in the product that is covered by this License, on a durable physical medium customarily used for software interchange, for a price no more than your reasonable cost of physically performing this conveying of source, or (2) access to copy the Corresponding Source from a network server at no charge.

c) Convey individual copies of the object code with a copy of the written offer to provide the Corresponding Source. This alternative is allowed only occasionally and noncommercially, and only if you received the object code with such an offer, in accord with subsection 6b.

d) Convey the object code by offering access from a designated place (gratis or for a charge), and offer equivalent access to the Corresponding Source in the same way through the same place at no further charge. You need not require recipients to copy the Corresponding Source along with the object code. If the place to copy the object code is a network server, the Corresponding Source may be on a different server (operated by you or a third party) that supports equivalent copying facilities, provided you maintain clear directions next to the object code saying where to find the Corresponding Source. Regardless of what server hosts the Corresponding Source, you remain obligated to ensure that it is available for as long as needed to satisfy these requirements.

e) Convey the object code using peer-to-peer transmission, provided you inform other peers where the object code and Corresponding Source of the work are being offered to the general public at no charge under subsection 6d.

A separable portion of the object code, whose source code is excluded from the Corresponding Source as a System Library, need not be included in conveying the object code work.

A "User Product" is either (1) a "consumer product", which means any tangible personal property which is normally used for personal, family, or household purposes, or (2) anything designed or sold for incorporation into a dwelling. In determining whether a product is a consumer product, doubtful

cases shall be resolved in favor of coverage. For a particular product received by a particular user, "normally used" refers to a typical or common use of that class of product, regardless of the status of the particular user or of the way in which the particular user actually uses, or expects or is expected to use, the product. A product is a consumer product regardless of whether the product has substantial commercial, industrial or non-consumer uses, unless such uses represent the only significant mode of use of the product.

"Installation Information" for a User Product means any methods, procedures, authorization keys, or other information required to install and execute modified versions of a covered work in that User Product from a modified version of its Corresponding Source. The information must suffice to ensure that the continued functioning of the modified object code is in no case prevented or interfered with solely because modification has been made.

If you convey an object code work under this section in, or with, or specifically for use in, a User Product, and the conveying occurs as part of a transaction in which the right of possession and use of the User Product is transferred to the recipient in perpetuity or for a fixed term (regardless of how the transaction is characterized), the Corresponding Source conveyed under this section must be accompanied by the Installation Information. But this requirement does not apply if neither you nor any third party retains the ability to install modified object code on the User Product (for example, the work has been installed in ROM).

The requirement to provide Installation Information does not include a requirement to continue to provide support service, warranty, or updates for a work that has been modified or installed by the recipient, or for the User Product in which it has been modified or installed. Access to a network may be denied when the modification itself materially and adversely affects the operation of the network or violates the rules and protocols for communication across the network.

Corresponding Source conveyed, and Installation Information provided, in accord with this section must be in a format that is publicly documented (and with an implementation available to the public in source code form), and must require no special password or key for unpacking, reading or copying.

7. Additional Terms.

"Additional permissions" are terms that supplement the terms of this License by making exceptions from one or more of its conditions. Additional permissions that are applicable to the entire Program shall be treated as though they were included in this License, to the extent that they are valid under applicable law. If additional permissions apply only to part of the Program, that part may be used separately under those permissions, but the entire Program remains governed by this License without regard to the additional permissions.

When you convey a copy of a covered work, you may at your option remove any additional permissions from that copy, or from any part of it. (Additional permissions may be written to require their own removal in certain cases when you modify the work.) You may place additional permissions on material, added by you to a covered work, for which you have or can give appropriate copyright permission.

Notwithstanding any other provision of this License, for material you add to a covered work, you may (if authorized by the copyright holders of that material) supplement the terms of this License with terms:

a) Disclaiming warranty or limiting liability differently from the terms of sections 15 and 16 of this License; or

b) Requiring preservation of specified reasonable legal notices or author attributions in that material or in the Appropriate Legal Notices displayed by works containing it; or

c) Prohibiting misrepresentation of the origin of that material, or requiring that modified versions of such material be marked in reasonable ways as different from the original version; or

d) Limiting the use for publicity purposes of names of licensors or authors of the material; or

e) Declining to grant rights under trademark law for use of some trade names, trademarks, or service marks; or

f) Requiring indemnification of licensors and authors of that material by anyone who conveys the material (or modified versions of it) with contractual assumptions of liability to the recipient, for any liability that these contractual assumptions directly impose on those licensors and authors.

All other non-permissive additional terms are considered "further restrictions" within the meaning of section 10. If the Program as you received it, or any part of it, contains a notice stating that it is governed by this License along with a term that is a further restriction, you may remove that term. If a license document contains a further restriction but permits relicensing or conveying under this License, you may add to a covered work material governed by the terms of that license document, provided that the further restriction does not survive such relicensing or conveying.

If you add terms to a covered work in accord with this section, you must place, in the relevant source files, a statement of the additional terms that apply to those files, or a notice indicating where to find the applicable terms.

Additional terms, permissive or non-permissive, may be stated in the form

of a separately written license, or stated as exceptions; the above requirements apply either way.

8. Termination.

You may not propagate or modify a covered work except as expressly provided under this License. Any attempt otherwise to propagate or modify it is void, and will automatically terminate your rights under this License (including any patent licenses granted under the third paragraph of section 11).

However, if you cease all violation of this License, then your license from a particular copyright holder is reinstated (a) provisionally, unless and until the copyright holder explicitly and finally terminates your license, and (b) permanently, if the copyright holder fails to notify you of the violation by some reasonable means prior to 60 days after the cessation.

Moreover, your license from a particular copyright holder is reinstated permanently if the copyright holder notifies you of the violation by some reasonable means, this is the first time you have received notice of violation of this License (for any work) from that copyright holder, and you cure the violation prior to 30 days after your receipt of the notice.

Termination of your rights under this section does not terminate the licenses of parties who have received copies or rights from you under this License. If your rights have been terminated and not permanently reinstated, you do not qualify to receive new licenses for the same material under section 10.

9. Acceptance Not Required for Having Copies.

You are not required to accept this License in order to receive or run a copy of the Program. Ancillary propagation of a covered work occurring solely as a consequence of using peer-to-peer transmission to receive a copy likewise does not require acceptance. However, nothing other than this License grants you permission to propagate or modify any covered work. These actions infringe copyright if you do not accept this License. Therefore, by modifying or propagating a covered work, you indicate your acceptance of this License to do so.

10. Automatic Licensing of Downstream Recipients.

Each time you convey a covered work, the recipient automatically receives a license from the original licensors, to run, modify and propagate that work, subject to this License. You are not responsible for enforcing compliance by third parties with this License.

An "entity transaction" is a transaction transferring control of an organization, or substantially all assets of one, or subdividing an organization, or merging organizations. If propagation of a covered work

results from an entity transaction, each party to that transaction who receives a copy of the work also receives whatever licenses to the work the party's predecessor in interest had or could give under the previous paragraph, plus a right to possession of the Corresponding Source of the work from the predecessor in interest, if the predecessor has it or can get it with reasonable efforts.

You may not impose any further restrictions on the exercise of the rights granted or affirmed under this License. For example, you may not impose a license fee, royalty, or other charge for exercise of rights granted under this License, and you may not initiate litigation (including a cross-claim or counterclaim in a lawsuit) alleging that any patent claim is infringed by making, using, selling, offering for sale, or importing the Program or any portion of it.

11. Patents.

A "contributor" is a copyright holder who authorizes use under this License of the Program or a work on which the Program is based. The work thus licensed is called the contributor's "contributor version".

A contributor's "essential patent claims" are all patent claims owned or controlled by the contributor, whether already acquired or hereafter acquired, that would be infringed by some manner, permitted by this License, of making, using, or selling its contributor version, but do not include claims that would be infringed only as a consequence of further modification of the contributor version. For purposes of this definition, "control" includes the right to grant patent sublicenses in a manner consistent with the requirements of this License.

Each contributor grants you a non-exclusive, worldwide, royalty-free patent license under the contributor's essential patent claims, to make, use, sell, offer for sale, import and otherwise run, modify and propagate the contents of its contributor version.

In the following three paragraphs, a "patent license" is any express agreement or commitment, however denominated, not to enforce a patent (such as an express permission to practice a patent or covenant not to sue for patent infringement). To "grant" such a patent license to a party means to make such an agreement or commitment not to enforce a patent against the party.

If you convey a covered work, knowingly relying on a patent license, and the Corresponding Source of the work is not available for anyone to copy, free of charge and under the terms of this License, through a publicly available network server or other readily accessible means, then you must either (1) cause the Corresponding Source to be so available, or (2) arrange to deprive yourself of the benefit of the patent license for this particular work, or (3) arrange, in a manner consistent with the requirements of this

License, to extend the patent license to downstream recipients. "Knowingly relying" means you have actual knowledge that, but for the patent license, your conveying the covered work in a country, or your recipient's use of the covered work in a country, would infringe one or more identifiable patents in that country that you have reason to believe are valid.

If, pursuant to or in connection with a single transaction or arrangement, you convey, or propagate by procuring conveyance of, a covered work, and grant a patent license to some of the parties receiving the covered work authorizing them to use, propagate, modify or convey a specific copy of the covered work, then the patent license you grant is automatically extended to all recipients of the covered work and works based on it.

A patent license is "discriminatory" if it does not include within the scope of its coverage, prohibits the exercise of, or is conditioned on the non-exercise of one or more of the rights that are specifically granted under this License. You may not convey a covered work if you are a party to an arrangement with a third party that is in the business of distributing software, under which you make payment to the third party based on the extent of your activity of conveying the work, and under which the third party grants, to any of the parties who would receive the covered work from you, a discriminatory patent license (a) in connection with copies of the covered work conveyed by you (or copies made from those copies), or (b) primarily for and in connection with specific products or compilations that contain the covered work, unless you entered into that arrangement, or that patent license was granted, prior to 28 March 2007.

Nothing in this License shall be construed as excluding or limiting any implied license or other defenses to infringement that may otherwise be available to you under applicable patent law.

12. No Surrender of Others' Freedom.

If conditions are imposed on you (whether by court order, agreement or otherwise) that contradict the conditions of this License, they do not excuse you from the conditions of this License. If you cannot convey a covered work so as to satisfy simultaneously your obligations under this License and any other pertinent obligations, then as a consequence you may not convey it at all. For example, if you agree to terms that obligate you to collect a royalty for further conveying from those to whom you convey the Program, the only way you could satisfy both those terms and this License would be to refrain entirely from conveying the Program.

13. Use with the GNU Affero General Public License.

Notwithstanding any other provision of this License, you have permission to link or combine any covered work with a work licensed under version 3 of the GNU Affero General Public License into a single combined work, and to convey the resulting work. The terms of this License will continue to apply to the

part which is the covered work, but the special requirements of the GNU Affero General Public License, section 13, concerning interaction through a network will apply to the combination as such.

14. Revised Versions of this License.

The Free Software Foundation may publish revised and/or new versions of the GNU General Public License from time to time. Such new versions will be similar in spirit to the present version, but may differ in detail to address new problems or concerns.

Each version is given a distinguishing version number. If the Program specifies that a certain numbered version of the GNU General Public License "or any later version" applies to it, you have the option of following the terms and conditions either of that numbered version or of any later version published by the Free Software Foundation. If the Program does not specify a version number of the GNU General Public License, you may choose any version ever published by the Free Software Foundation.

If the Program specifies that a proxy can decide which future versions of the GNU General Public License can be used, that proxy's public statement of acceptance of a version permanently authorizes you to choose that version for the Program.

Later license versions may give you additional or different permissions. However, no additional obligations are imposed on any author or copyright holder as a result of your choosing to follow a later version.

15. Disclaimer of Warranty.

THERE IS NO WARRANTY FOR THE PROGRAM, TO THE EXTENT PERMITTED BY APPLICABLE LAW. EXCEPT WHEN OTHERWISE STATED IN WRITING THE COPYRIGHT HOLDERS AND/OR OTHER PARTIES PROVIDE THE PROGRAM "AS IS" WITHOUT WARRANTY OF ANY KIND, EITHER EXPRESSED OR IMPLIED, INCLUDING, BUT NOT LIMITED TO, THE IMPLIED WARRANTIES OF MERCHANTABILITY AND FITNESS FOR A PARTICULAR PURPOSE. THE ENTIRE RISK AS TO THE QUALITY AND PERFORMANCE OF THE PROGRAM IS WITH YOU. SHOULD THE PROGRAM PROVE DEFECTIVE, YOU ASSUME THE COST OF ALL NECESSARY SERVICING, REPAIR OR CORRECTION.

16. Limitation of Liability.

IN NO EVENT UNLESS REQUIRED BY APPLICABLE LAW OR AGREED TO IN WRITING WILL ANY COPYRIGHT HOLDER, OR ANY OTHER PARTY WHO MODIFIES AND/OR CONVEYS THE PROGRAM AS PERMITTED ABOVE, BE LIABLE TO YOU FOR DAMAGES, INCLUDING ANY GENERAL, SPECIAL, INCIDENTAL OR CONSEQUENTIAL DAMAGES ARISING OUT OF THE USE OR INABILITY TO USE THE PROGRAM (INCLUDING BUT NOT LIMITED TO LOSS OF DATA OR DATA BEING RENDERED INACCURATE OR LOSSES SUSTAINED BY YOU OR THIRD PARTIES OR A FAILURE OF THE PROGRAM TO OPERATE WITH ANY OTHER PROGRAMS), EVEN IF SUCH HOLDER OR OTHER PARTY HAS BEEN ADVISED OF THE POSSIBILITY OF SUCH DAMAGES.

17. Interpretation of Sections 15 and 16.

If the disclaimer of warranty and limitation of liability provided above cannot be given local legal effect according to their terms, reviewing courts shall apply local law that most closely approximates an absolute waiver of all civil liability in connection with the Program, unless a warranty or assumption of liability accompanies a copy of the Program in return for a fee.

END OF TERMS AND CONDITIONS

How to Apply These Terms to Your New Programs

If you develop a new program, and you want it to be of the greatest possible use to the public, the best way to achieve this is to make it free software which everyone can redistribute and change under these terms.

To do so, attach the following notices to the program. It is safest to attach them to the start of each source file to most effectively state the exclusion of warranty; and each file should have at least the "copyright" line and a pointer to where the full notice is found.

```
<one line to give the program's name and a brief idea of what it does.>
Copyright (C) <year> <name of author>
```

This program is free software: you can redistribute it and/or modify it under the terms of the GNU General Public License as published by the Free Software Foundation, either version 3 of the License, or (at your option) any later version.

This program is distributed in the hope that it will be useful, but WITHOUT ANY WARRANTY; without even the implied warranty of MERCHANTABILITY or FITNESS FOR A PARTICULAR PURPOSE. See the GNU General Public License for more details.

You should have received a copy of the GNU General Public License along with this program. If not, see <http://www.gnu.org/licenses/>.

Also add information on how to contact you by electronic and paper mail.

If the program does terminal interaction, make it output a short notice like this when it starts in an interactive mode:

```
<program> Copyright (C) <year> <name of author>
This program comes with ABSOLUTELY NO WARRANTY; for details type `show
w'.
```

```
This is free software, and you are welcome to redistribute it
under certain conditions; type `show c' for details.
```

The hypothetical commands ``show w'` and ``show c'` should show the appropriate parts of the General Public License. Of course, your program's commands might be different; for a GUI interface, you would use an "about box".

You should also get your employer (if you work as a programmer) or school, if any, to sign a "copyright disclaimer" for the program, if necessary. For more information on this, and how to apply and follow the GNU GPL, see <http://www.gnu.org/licenses/>.

The GNU General Public License does not permit incorporating your program into proprietary programs. If your program is a subroutine library, you may consider it more useful to permit linking proprietary applications with the library. If this is what you want to do, use the GNU Lesser General Public License instead of this License. But first, please read

<http://www.gnu.org/philosophy/why-not-lgpl.html>.

27.10 Mongoose — MIT License

Copyright (c) 2004-2013 Sergey Lyubka

Permission is hereby granted, free of charge, to any person obtaining a copy of this software and associated documentation files (the "Software"), to deal in the Software without restriction, including without limitation the rights to use, copy, modify, merge, publish, distribute, sublicense, and/or sell copies of the Software, and to permit persons to whom the Software is furnished to do so, subject to the following conditions:

The above copyright notice and this permission notice shall be included in all copies or substantial portions of the Software.

THE SOFTWARE IS PROVIDED "AS IS", WITHOUT WARRANTY OF ANY KIND, EXPRESS OR IMPLIED, INCLUDING BUT NOT LIMITED TO THE WARRANTIES OF MERCHANTABILITY, FITNESS FOR A PARTICULAR PURPOSE AND NONINFRINGEMENT. IN NO EVENT SHALL THE AUTHORS OR COPYRIGHT HOLDERS BE LIABLE FOR ANY CLAIM, DAMAGES OR OTHER LIABILITY, WHETHER IN AN ACTION OF CONTRACT, TORT OR OTHERWISE, ARISING FROM, OUT OF OR IN CONNECTION WITH THE SOFTWARE OR THE USE OR OTHER DEALINGS IN THE SOFTWARE.

27.11 MVVM Light Toolkit — MIT License

MVVM Light Toolkit

<http://mvvmlight.codeplex.com/>

License: The MIT License (MIT)

Copyright (c) 2009 - 2011 Laurent Bugnion

Permission is hereby granted, free of charge, to any person obtaining a copy of this software and associated documentation files (the "Software"), to deal in the Software without restriction, including without limitation the rights to use, copy, modify, merge, publish, distribute, sublicense, and/or sell copies of the Software, and to permit persons to whom the Software is furnished to do so, subject to the following conditions:

The above copyright notice and this permission notice shall be included in all copies or substantial portions of the Software.

THE SOFTWARE IS PROVIDED "AS IS", WITHOUT WARRANTY OF ANY KIND, EXPRESS OR IMPLIED, INCLUDING BUT NOT LIMITED TO THE WARRANTIES OF MERCHANTABILITY, FITNESS FOR A PARTICULAR PURPOSE AND NONINFRINGEMENT. IN NO EVENT SHALL THE AUTHORS OR COPYRIGHT HOLDERS BE LIABLE FOR ANY CLAIM, DAMAGES OR OTHER LIABILITY, WHETHER IN AN ACTION OF CONTRACT, TORT OR OTHERWISE, ARISING FROM, OUT OF OR IN CONNECTION WITH THE SOFTWARE OR THE USE OR OTHER DEALINGS IN THE SOFTWARE.

27.12 pugixml — MIT License

Copyright (c) 2006-2012 Arseny Kapoulkine

Permission is hereby granted, free of charge, to any person obtaining a copy of this software and associated documentation files (the "Software"), to deal in the Software without restriction, including without limitation the rights to use, copy, modify, merge, publish, distribute, sublicense, and/or sell copies of the Software, and to permit persons to whom the Software is furnished to do so, subject to the following conditions:

The above copyright notice and this permission notice shall be included in all copies or substantial portions of the Software.

THE SOFTWARE IS PROVIDED "AS IS", WITHOUT WARRANTY OF ANY KIND, EXPRESS OR IMPLIED, INCLUDING BUT NOT LIMITED TO THE WARRANTIES OF MERCHANTABILITY, FITNESS FOR A PARTICULAR PURPOSE AND NONINFRINGEMENT. IN NO EVENT SHALL THE AUTHORS OR COPYRIGHT HOLDERS BE LIABLE FOR ANY CLAIM, DAMAGES OR OTHER LIABILITY, WHETHER IN AN ACTION OF CONTRACT, TORT OR OTHERWISE, ARISING FROM, OUT OF OR IN CONNECTION WITH THE SOFTWARE OR THE USE OR OTHER DEALINGS IN THE SOFTWARE.

27.13 Qt — LGPL3 License

GNU LESSER GENERAL PUBLIC LICENSE

Version 3, 29 June 2007

Copyright © 2007 Free Software Foundation, Inc.

Everyone is permitted to copy and distribute verbatim copies of this license document, but changing it is not allowed.

This version of the GNU Lesser General Public License incorporates the terms and conditions of version 3 of the GNU General Public License, supplemented by the additional permissions listed below.

0. Additional Definitions.

As used herein, "this License" refers to version 3 of the GNU Lesser General Public License, and the "GNU GPL" refers to version 3 of the GNU General Public License.

"The Library" refers to a covered work governed by this License, other than an Application or a Combined Work as defined below.

An "Application" is any work that makes use of an interface provided by the Library, but which is not otherwise based on the Library. Defining a subclass of a class defined by the Library is deemed a mode of using an interface provided by the Library.

A "Combined Work" is a work produced by combining or linking an Application with the Library. The particular version of the Library with which the Combined Work was made is also called the "Linked Version".

The "Minimal Corresponding Source" for a Combined Work means the Corresponding Source for the Combined Work, excluding any source code for portions of the Combined Work that, considered in isolation, are based on the Application, and not on the Linked Version.

The "Corresponding Application Code" for a Combined Work means the object code and/or source code for the Application, including any data and utility programs needed for reproducing the Combined Work from the Application, but excluding the System Libraries of the Combined Work.

1. Exception to Section 3 of the GNU GPL.

You may convey a covered work under sections 3 and 4 of this License without being bound by section 3 of the GNU GPL.

2. Conveying Modified Versions.

If you modify a copy of the Library, and, in your modifications, a facility refers to a function or data to be supplied by an Application that uses the facility (other than as an argument passed when the facility is invoked), then you may convey a copy of the modified version:

- a) under this License, provided that you make a good faith effort to

ensure that, in the event an Application does not supply the function or data, the facility still operates, and performs whatever part of its purpose remains meaningful, or

b) under the GNU GPL, with none of the additional permissions of this License applicable to that copy.

3. Object Code Incorporating Material from Library Header Files.

The object code form of an Application may incorporate material from a header file that is part of the Library. You may convey such object code under terms of your choice, provided that, if the incorporated material is not limited to numerical parameters, data structure layouts and accessors, or small macros, inline functions and templates (ten or fewer lines in length), you do both of the following:

a) Give prominent notice with each copy of the object code that the Library is used in it and that the Library and its use are covered by this License.

b) Accompany the object code with a copy of the GNU GPL and this license document.

4. Combined Works.

You may convey a Combined Work under terms of your choice that, taken together, effectively do not restrict modification of the portions of the Library contained in the Combined Work and reverse engineering for debugging such modifications, if you also do each of the following:

a) Give prominent notice with each copy of the Combined Work that the Library is used in it and that the Library and its use are covered by this License.

b) Accompany the Combined Work with a copy of the GNU GPL and this license document.

c) For a Combined Work that displays copyright notices during execution, include the copyright notice for the Library among these notices, as well as a reference directing the user to the copies of the GNU GPL and this license document.

d) Do one of the following:

- 0) Convey the Minimal Corresponding Source under the terms of this License, and the Corresponding Application Code in a form suitable for, and under terms that permit, the user to recombine or relink the Application with a modified version of the Linked Version to produce a modified Combined Work, in the manner specified by section 6 of the GNU GPL for conveying Corresponding Source.

◦1) Use a suitable shared library mechanism for linking with the Library. A suitable mechanism is one that (a) uses at run time a copy of the Library already present on the user's computer system, and (b) will operate properly with a modified version of the Library that is interface-compatible with the Linked Version.

e) Provide Installation Information, but only if you would otherwise be required to provide such information under section 6 of the GNU GPL, and only to the extent that such information is necessary to install and execute a

modified version of the Combined Work produced by recombining or relinking the Application with a modified version of the Linked Version. (If you use option 4d0, the Installation Information must accompany the Minimal Corresponding Source and Corresponding Application Code. If you use option 4d1, you must provide the Installation Information in the manner specified by section 6 of the GNU GPL for conveying Corresponding Source.)

5. Combined Libraries.

You may place library facilities that are a work based on the Library side by side in a single library together with other library facilities that are not Applications and are not covered by this License, and convey such a combined library under terms of your choice, if you do both of the following:

a) Accompany the combined library with a copy of the same work based on the Library, uncombined with any other library facilities, conveyed under the terms of this License.

b) Give prominent notice with the combined library that part of it is a work based on the Library, and explaining where to find the accompanying uncombined form of the same work.

6. Revised Versions of the GNU Lesser General Public License.

The Free Software Foundation may publish revised and/or new versions of the GNU Lesser General Public License from time to time. Such new versions will be similar in spirit to the present version, but may differ in detail to address new problems or concerns.

Each version is given a distinguishing version number. If the Library as you received it specifies that a certain numbered version of the GNU Lesser General Public License "or any later version" applies to it, you have the option of following the terms and conditions either of that published version or of any later version published by the Free Software Foundation. If the Library as you received it does not specify a version number of the GNU Lesser General Public License, you may choose any version of the GNU Lesser General Public License ever published by the Free Software Foundation.

If the Library as you received it specifies that a proxy can decide whether future versions of the GNU Lesser General Public License shall apply, that proxy's public statement of acceptance of any version is permanent authorization for you to choose that version for the Library.

27.14 Qwt — GNU Lesser General Public License

GNU GENERAL PUBLIC LICENSE
Version 3, 29 June 2007

Copyright (C) 2007 Free Software Foundation, Inc. <<http://fsf.org/>>
Everyone is permitted to copy and distribute verbatim copies of this license document, but changing it is not allowed.

Preamble

The GNU General Public License is a free, copyleft license for software and other kinds of works.

The licenses for most software and other practical works are designed to take away your freedom to share and change the works. By contrast, the GNU General Public License is intended to guarantee your freedom to share and change all versions of a program--to make sure it remains free software for all its users. We, the Free Software Foundation, use the GNU General Public License for most of our software; it applies also to any other work released this way by its authors. You can apply it to your programs, too.

When we speak of free software, we are referring to freedom, not price. Our General Public Licenses are designed to make sure that you have the freedom to distribute copies of free software (and charge for them if you wish), that you receive source code or can get it if you want it, that you can change the software or use pieces of it in new free programs, and that you know you can do these things.

To protect your rights, we need to prevent others from denying you these rights or asking you to surrender the rights. Therefore, you have certain responsibilities if you distribute copies of the software, or if you modify it: responsibilities to respect the freedom of others.

For example, if you distribute copies of such a program, whether gratis or for a fee, you must pass on to the recipients the same freedoms that you received. You must make sure that they, too, receive or can get the source code. And you must show them these terms so they know their rights.

Developers that use the GNU GPL protect your rights with two steps: (1) assert copyright on the software, and (2) offer you this License giving you legal permission to copy, distribute and/or modify it.

For the developers' and authors' protection, the GPL clearly explains that there is no warranty for this free software. For both users' and authors' sake, the GPL requires that modified versions be marked as changed, so that their problems will not be attributed erroneously to authors of previous versions.

Some devices are designed to deny users access to install or run modified versions of the software inside them, although the manufacturer can do so. This is fundamentally incompatible with the aim of protecting users' freedom to change the software. The systematic pattern of such abuse occurs in the area of products for individuals to use, which is precisely where it is most unacceptable. Therefore, we have designed this version of the GPL to prohibit the practice for those products. If such problems arise substantially in other domains, we stand ready to extend this provision to those domains in

future versions of the GPL, as needed to protect the freedom of users.

Finally, every program is threatened constantly by software patents. States should not allow patents to restrict development and use of software on general-purpose computers, but in those that do, we wish to avoid the special danger that patents applied to a free program could make it effectively proprietary. To prevent this, the GPL assures that patents cannot be used to render the program non-free.

The precise terms and conditions for copying, distribution and modification follow.

TERMS AND CONDITIONS

0. Definitions.

"This License" refers to version 3 of the GNU General Public License.

"Copyright" also means copyright-like laws that apply to other kinds of works, such as semiconductor masks.

"The Program" refers to any copyrightable work licensed under this License. Each licensee is addressed as "you". "Licensees" and "recipients" may be individuals or organizations.

To "modify" a work means to copy from or adapt all or part of the work in a fashion requiring copyright permission, other than the making of an exact copy. The resulting work is called a "modified version" of the earlier work or a work "based on" the earlier work.

A "covered work" means either the unmodified Program or a work based on the Program.

To "propagate" a work means to do anything with it that, without permission, would make you directly or secondarily liable for infringement under applicable copyright law, except executing it on a computer or modifying a private copy. Propagation includes copying, distribution (with or without modification), making available to the public, and in some countries other activities as well.

To "convey" a work means any kind of propagation that enables other parties to make or receive copies. Mere interaction with a user through a computer network, with no transfer of a copy, is not conveying.

An interactive user interface displays "Appropriate Legal Notices" to the extent that it includes a convenient and prominently visible feature that (1) displays an appropriate copyright notice, and (2) tells the user that there is no warranty for the work (except to the extent that warranties are provided), that licensees may convey the work under this License, and how to

view a copy of this License. If the interface presents a list of user commands or options, such as a menu, a prominent item in the list meets this criterion.

1. Source Code.

The "source code" for a work means the preferred form of the work for making modifications to it. "Object code" means any non-source form of a work.

A "Standard Interface" means an interface that either is an official standard defined by a recognized standards body, or, in the case of interfaces specified for a particular programming language, one that is widely used among developers working in that language.

The "System Libraries" of an executable work include anything, other than the work as a whole, that (a) is included in the normal form of packaging a Major Component, but which is not part of that Major Component, and (b) serves only to enable use of the work with that Major Component, or to implement a Standard Interface for which an implementation is available to the public in source code form. A "Major Component", in this context, means a major essential component (kernel, window system, and so on) of the specific operating system (if any) on which the executable work runs, or a compiler used to produce the work, or an object code interpreter used to run it.

The "Corresponding Source" for a work in object code form means all the source code needed to generate, install, and (for an executable work) run the object code and to modify the work, including scripts to control those activities. However, it does not include the work's System Libraries, or general-purpose tools or generally available free programs which are used unmodified in performing those activities but which are not part of the work. For example, Corresponding Source includes interface definition files associated with source files for the work, and the source code for shared libraries and dynamically linked subprograms that the work is specifically designed to require, such as by intimate data communication or control flow between those subprograms and other parts of the work.

The Corresponding Source need not include anything that users can regenerate automatically from other parts of the Corresponding Source.

The Corresponding Source for a work in source code form is that same work.

2. Basic Permissions.

All rights granted under this License are granted for the term of copyright on the Program, and are irrevocable provided the stated conditions are met. This License explicitly affirms your unlimited permission to run the unmodified Program. The output from running a covered work is covered by this License only if the output, given its content, constitutes a covered work.

This License acknowledges your rights of fair use or other equivalent, as provided by copyright law.

You may make, run and propagate covered works that you do not convey, without conditions so long as your license otherwise remains in force. You may convey covered works to others for the sole purpose of having them make modifications exclusively for you, or provide you with facilities for running those works, provided that you comply with the terms of this License in conveying all material for which you do not control copyright. Those thus making or running the covered works for you must do so exclusively on your behalf, under your direction and control, on terms that prohibit them from making any copies of your copyrighted material outside their relationship with you.

Conveying under any other circumstances is permitted solely under the conditions stated below. Sublicensing is not allowed; section 10 makes it unnecessary.

3. Protecting Users' Legal Rights From Anti-Circumvention Law.

No covered work shall be deemed part of an effective technological measure under any applicable law fulfilling obligations under article 11 of the WIPO copyright treaty adopted on 20 December 1996, or similar laws prohibiting or restricting circumvention of such measures.

When you convey a covered work, you waive any legal power to forbid circumvention of technological measures to the extent such circumvention is effected by exercising rights under this License with respect to the covered work, and you disclaim any intention to limit operation or modification of the work as a means of enforcing, against the work's users, your or third parties' legal rights to forbid circumvention of technological measures.

4. Conveying Verbatim Copies.

You may convey verbatim copies of the Program's source code as you receive it, in any medium, provided that you conspicuously and appropriately publish on each copy an appropriate copyright notice; keep intact all notices stating that this License and any non-permissive terms added in accord with section 7 apply to the code; keep intact all notices of the absence of any warranty; and give all recipients a copy of this License along with the Program.

You may charge any price or no price for each copy that you convey, and you may offer support or warranty protection for a fee.

5. Conveying Modified Source Versions.

You may convey a work based on the Program, or the modifications to produce it from the Program, in the form of source code under the terms of section 4, provided that you also meet all of these conditions:

a) The work must carry prominent notices stating that you modified it, and giving a relevant date.

b) The work must carry prominent notices stating that it is released under this License and any conditions added under section 7. This requirement modifies the requirement in section 4 to "keep intact all notices".

c) You must license the entire work, as a whole, under this License to anyone who comes into possession of a copy. This License will therefore apply, along with any applicable section 7 additional terms, to the whole of the work, and all its parts, regardless of how they are packaged. This License gives no permission to license the work in any other way, but it does not invalidate such permission if you have separately received it.

d) If the work has interactive user interfaces, each must display Appropriate Legal Notices; however, if the Program has interactive interfaces that do not display Appropriate Legal Notices, your work need not make them do so.

A compilation of a covered work with other separate and independent works, which are not by their nature extensions of the covered work, and which are not combined with it such as to form a larger program, in or on a volume of a storage or distribution medium, is called an "aggregate" if the compilation and its resulting copyright are not used to limit the access or legal rights of the compilation's users beyond what the individual works permit. Inclusion of a covered work in an aggregate does not cause this License to apply to the other parts of the aggregate.

6. Conveying Non-Source Forms.

You may convey a covered work in object code form under the terms of sections 4 and 5, provided that you also convey the machine-readable Corresponding Source under the terms of this License, in one of these ways:

a) Convey the object code in, or embodied in, a physical product (including a physical distribution medium), accompanied by the Corresponding Source fixed on a durable physical medium customarily used for software interchange.

b) Convey the object code in, or embodied in, a physical product (including a physical distribution medium), accompanied by a written offer, valid for at least three years and valid for as long as you offer spare parts or customer support for that product model, to give anyone who possesses the object code either (1) a copy of the Corresponding Source for all the software in the product that is covered by this License, on a durable physical medium customarily used for software interchange, for a price no more than your reasonable cost of physically performing this conveying of source, or (2) access to copy the Corresponding Source from a network server

at no charge.

c) Convey individual copies of the object code with a copy of the written offer to provide the Corresponding Source. This alternative is allowed only occasionally and noncommercially, and only if you received the object code with such an offer, in accord with subsection 6b.

d) Convey the object code by offering access from a designated place (gratis or for a charge), and offer equivalent access to the Corresponding Source in the same way through the same place at no further charge. You need not require recipients to copy the Corresponding Source along with the object code. If the place to copy the object code is a network server, the Corresponding Source may be on a different server (operated by you or a third party) that supports equivalent copying facilities, provided you maintain clear directions next to the object code saying where to find the Corresponding Source. Regardless of what server hosts the Corresponding Source, you remain obligated to ensure that it is available for as long as needed to satisfy these requirements.

e) Convey the object code using peer-to-peer transmission, provided you inform other peers where the object code and Corresponding Source of the work are being offered to the general public at no charge under subsection 6d.

A separable portion of the object code, whose source code is excluded from the Corresponding Source as a System Library, need not be included in conveying the object code work.

A "User Product" is either (1) a "consumer product", which means any tangible personal property which is normally used for personal, family, or household purposes, or (2) anything designed or sold for incorporation into a dwelling. In determining whether a product is a consumer product, doubtful cases shall be resolved in favor of coverage. For a particular product received by a particular user, "normally used" refers to a typical or common use of that class of product, regardless of the status of the particular user or of the way in which the particular user actually uses, or expects or is expected to use, the product. A product is a consumer product regardless of whether the product has substantial commercial, industrial or non-consumer uses, unless such uses represent the only significant mode of use of the product.

"Installation Information" for a User Product means any methods, procedures, authorization keys, or other information required to install and execute modified versions of a covered work in that User Product from a modified version of its Corresponding Source. The information must suffice to ensure that the continued functioning of the modified object code is in no case prevented or interfered with solely because modification has been made.

If you convey an object code work under this section in, or with, or specifically for use in, a User Product, and the conveying occurs as part of

a transaction in which the right of possession and use of the User Product is transferred to the recipient in perpetuity or for a fixed term (regardless of how the transaction is characterized), the Corresponding Source conveyed under this section must be accompanied by the Installation Information. But this requirement does not apply if neither you nor any third party retains the ability to install modified object code on the User Product (for example, the work has been installed in ROM).

The requirement to provide Installation Information does not include a requirement to continue to provide support service, warranty, or updates for a work that has been modified or installed by the recipient, or for the User Product in which it has been modified or installed. Access to a network may be denied when the modification itself materially and adversely affects the operation of the network or violates the rules and protocols for communication across the network.

Corresponding Source conveyed, and Installation Information provided, in accord with this section must be in a format that is publicly documented (and with an implementation available to the public in source code form), and must require no special password or key for unpacking, reading or copying.

7. Additional Terms.

"Additional permissions" are terms that supplement the terms of this License by making exceptions from one or more of its conditions. Additional permissions that are applicable to the entire Program shall be treated as though they were included in this License, to the extent that they are valid under applicable law. If additional permissions apply only to part of the Program, that part may be used separately under those permissions, but the entire Program remains governed by this License without regard to the additional permissions.

When you convey a copy of a covered work, you may at your option remove any additional permissions from that copy, or from any part of it. (Additional permissions may be written to require their own removal in certain cases when you modify the work.) You may place additional permissions on material, added by you to a covered work, for which you have or can give appropriate copyright permission.

Notwithstanding any other provision of this License, for material you add to a covered work, you may (if authorized by the copyright holders of that material) supplement the terms of this License with terms:

a) Disclaiming warranty or limiting liability differently from the terms of sections 15 and 16 of this License; or

b) Requiring preservation of specified reasonable legal notices or author attributions in that material or in the Appropriate Legal Notices displayed by works containing it; or

c) Prohibiting misrepresentation of the origin of that material, or requiring that modified versions of such material be marked in reasonable ways as different from the original version; or

d) Limiting the use for publicity purposes of names of licensors or authors of the material; or

e) Declining to grant rights under trademark law for use of some trade names, trademarks, or service marks; or

f) Requiring indemnification of licensors and authors of that material by anyone who conveys the material (or modified versions of it) with contractual assumptions of liability to the recipient, for any liability that these contractual assumptions directly impose on those licensors and authors.

All other non-permissive additional terms are considered "further restrictions" within the meaning of section 10. If the Program as you received it, or any part of it, contains a notice stating that it is governed by this License along with a term that is a further restriction, you may remove that term. If a license document contains a further restriction but permits relicensing or conveying under this License, you may add to a covered work material governed by the terms of that license document, provided that the further restriction does not survive such relicensing or conveying.

If you add terms to a covered work in accord with this section, you must place, in the relevant source files, a statement of the additional terms that apply to those files, or a notice indicating where to find the applicable terms.

Additional terms, permissive or non-permissive, may be stated in the form of a separately written license, or stated as exceptions; the above requirements apply either way.

8. Termination.

You may not propagate or modify a covered work except as expressly provided under this License. Any attempt otherwise to propagate or modify it is void, and will automatically terminate your rights under this License (including any patent licenses granted under the third paragraph of section 11).

However, if you cease all violation of this License, then your license from a particular copyright holder is reinstated (a) provisionally, unless and until the copyright holder explicitly and finally terminates your license, and (b) permanently, if the copyright holder fails to notify you of the violation by some reasonable means prior to 60 days after the cessation.

Moreover, your license from a particular copyright holder is reinstated permanently if the copyright holder notifies you of the violation by some

reasonable means, this is the first time you have received notice of violation of this License (for any work) from that copyright holder, and you cure the violation prior to 30 days after your receipt of the notice.

Termination of your rights under this section does not terminate the licenses of parties who have received copies or rights from you under this License. If your rights have been terminated and not permanently reinstated, you do not qualify to receive new licenses for the same material under section 10.

9. Acceptance Not Required for Having Copies.

You are not required to accept this License in order to receive or run a copy of the Program. Ancillary propagation of a covered work occurring solely as a consequence of using peer-to-peer transmission to receive a copy likewise does not require acceptance. However, nothing other than this License grants you permission to propagate or modify any covered work. These actions infringe copyright if you do not accept this License. Therefore, by modifying or propagating a covered work, you indicate your acceptance of this License to do so.

10. Automatic Licensing of Downstream Recipients.

Each time you convey a covered work, the recipient automatically receives a license from the original licensors, to run, modify and propagate that work, subject to this License. You are not responsible for enforcing compliance by third parties with this License.

An "entity transaction" is a transaction transferring control of an organization, or substantially all assets of one, or subdividing an organization, or merging organizations. If propagation of a covered work results from an entity transaction, each party to that transaction who receives a copy of the work also receives whatever licenses to the work the party's predecessor in interest had or could give under the previous paragraph, plus a right to possession of the Corresponding Source of the work from the predecessor in interest, if the predecessor has it or can get it with reasonable efforts.

You may not impose any further restrictions on the exercise of the rights granted or affirmed under this License. For example, you may not impose a license fee, royalty, or other charge for exercise of rights granted under this License, and you may not initiate litigation (including a cross-claim or counterclaim in a lawsuit) alleging that any patent claim is infringed by making, using, selling, offering for sale, or importing the Program or any portion of it.

11. Patents.

A "contributor" is a copyright holder who authorizes use under this License

of the Program or a work on which the Program is based. The work thus licensed is called the contributor's "contributor version".

A contributor's "essential patent claims" are all patent claims owned or controlled by the contributor, whether already acquired or hereafter acquired, that would be infringed by some manner, permitted by this License, of making, using, or selling its contributor version, but do not include claims that would be infringed only as a consequence of further modification of the contributor version. For purposes of this definition, "control" includes the right to grant patent sublicenses in a manner consistent with the requirements of this License.

Each contributor grants you a non-exclusive, worldwide, royalty-free patent license under the contributor's essential patent claims, to make, use, sell, offer for sale, import and otherwise run, modify and propagate the contents of its contributor version.

In the following three paragraphs, a "patent license" is any express agreement or commitment, however denominated, not to enforce a patent (such as an express permission to practice a patent or covenant not to sue for patent infringement). To "grant" such a patent license to a party means to make such an agreement or commitment not to enforce a patent against the party.

If you convey a covered work, knowingly relying on a patent license, and the Corresponding Source of the work is not available for anyone to copy, free of charge and under the terms of this License, through a publicly available network server or other readily accessible means, then you must either (1) cause the Corresponding Source to be so available, or (2) arrange to deprive yourself of the benefit of the patent license for this particular work, or (3) arrange, in a manner consistent with the requirements of this License, to extend the patent license to downstream recipients. "Knowingly relying" means you have actual knowledge that, but for the patent license, your conveying the covered work in a country, or your recipient's use of the covered work in a country, would infringe one or more identifiable patents in that country that you have reason to believe are valid.

If, pursuant to or in connection with a single transaction or arrangement, you convey, or propagate by procuring conveyance of, a covered work, and grant a patent license to some of the parties receiving the covered work authorizing them to use, propagate, modify or convey a specific copy of the covered work, then the patent license you grant is automatically extended to all recipients of the covered work and works based on it.

A patent license is "discriminatory" if it does not include within the scope of its coverage, prohibits the exercise of, or is conditioned on the non-exercise of one or more of the rights that are specifically granted under this License. You may not convey a covered work if you are a party to an arrangement with a third party that is in the business of distributing

software, under which you make payment to the third party based on the extent of your activity of conveying the work, and under which the third party grants, to any of the parties who would receive the covered work from you, a discriminatory patent license (a) in connection with copies of the covered work conveyed by you (or copies made from those copies), or (b) primarily for and in connection with specific products or compilations that contain the covered work, unless you entered into that arrangement, or that patent license was granted, prior to 28 March 2007.

Nothing in this License shall be construed as excluding or limiting any implied license or other defenses to infringement that may otherwise be available to you under applicable patent law.

12. No Surrender of Others' Freedom.

If conditions are imposed on you (whether by court order, agreement or otherwise) that contradict the conditions of this License, they do not excuse you from the conditions of this License. If you cannot convey a covered work so as to satisfy simultaneously your obligations under this License and any other pertinent obligations, then as a consequence you may not convey it at all. For example, if you agree to terms that obligate you to collect a royalty for further conveying from those to whom you convey the Program, the only way you could satisfy both those terms and this License would be to refrain entirely from conveying the Program.

13. Use with the GNU Affero General Public License.

Notwithstanding any other provision of this License, you have permission to link or combine any covered work with a work licensed under version 3 of the GNU Affero General Public License into a single combined work, and to convey the resulting work. The terms of this License will continue to apply to the part which is the covered work, but the special requirements of the GNU Affero General Public License, section 13, concerning interaction through a network will apply to the combination as such.

14. Revised Versions of this License.

The Free Software Foundation may publish revised and/or new versions of the GNU General Public License from time to time. Such new versions will be similar in spirit to the present version, but may differ in detail to address new problems or concerns.

Each version is given a distinguishing version number. If the Program specifies that a certain numbered version of the GNU General Public License "or any later version" applies to it, you have the option of following the terms and conditions either of that numbered version or of any later version published by the Free Software Foundation. If the Program does not specify a version number of the GNU General Public License, you may choose any version ever published by the Free Software Foundation.

If the Program specifies that a proxy can decide which future versions of the GNU General Public License can be used, that proxy's public statement of acceptance of a version permanently authorizes you to choose that version for the Program.

Later license versions may give you additional or different permissions. However, no additional obligations are imposed on any author or copyright holder as a result of your choosing to follow a later version.

15. Disclaimer of Warranty.

THERE IS NO WARRANTY FOR THE PROGRAM, TO THE EXTENT PERMITTED BY APPLICABLE LAW. EXCEPT WHEN OTHERWISE STATED IN WRITING THE COPYRIGHT HOLDERS AND/OR OTHER PARTIES PROVIDE THE PROGRAM "AS IS" WITHOUT WARRANTY OF ANY KIND, EITHER EXPRESSED OR IMPLIED, INCLUDING, BUT NOT LIMITED TO, THE IMPLIED WARRANTIES OF MERCHANTABILITY AND FITNESS FOR A PARTICULAR PURPOSE. THE ENTIRE RISK AS TO THE QUALITY AND PERFORMANCE OF THE PROGRAM IS WITH YOU. SHOULD THE PROGRAM PROVE DEFECTIVE, YOU ASSUME THE COST OF ALL NECESSARY SERVICING, REPAIR OR CORRECTION.

16. Limitation of Liability.

IN NO EVENT UNLESS REQUIRED BY APPLICABLE LAW OR AGREED TO IN WRITING WILL ANY COPYRIGHT HOLDER, OR ANY OTHER PARTY WHO MODIFIES AND/OR CONVEYS THE PROGRAM AS PERMITTED ABOVE, BE LIABLE TO YOU FOR DAMAGES, INCLUDING ANY GENERAL, SPECIAL, INCIDENTAL OR CONSEQUENTIAL DAMAGES ARISING OUT OF THE USE OR INABILITY TO USE THE PROGRAM (INCLUDING BUT NOT LIMITED TO LOSS OF DATA OR DATA BEING RENDERED INACCURATE OR LOSSES SUSTAINED BY YOU OR THIRD PARTIES OR A FAILURE OF THE PROGRAM TO OPERATE WITH ANY OTHER PROGRAMS), EVEN IF SUCH HOLDER OR OTHER PARTY HAS BEEN ADVISED OF THE POSSIBILITY OF SUCH DAMAGES.

17. Interpretation of Sections 15 and 16.

If the disclaimer of warranty and limitation of liability provided above cannot be given local legal effect according to their terms, reviewing courts shall apply local law that most closely approximates an absolute waiver of all civil liability in connection with the Program, unless a warranty or assumption of liability accompanies a copy of the Program in return for a fee.

END OF TERMS AND CONDITIONS

How to Apply These Terms to Your New Programs

If you develop a new program, and you want it to be of the greatest possible use to the public, the best way to achieve this is to make it free software which everyone can redistribute and change under these terms.

To do so, attach the following notices to the program. It is safest to attach them to the start of each source file to most effectively state the exclusion of warranty; and each file should have at least the "copyright" line and a pointer to where the full notice is found.

```
<one line to give the program's name and a brief idea of what it does.>
Copyright (C) <year> <name of author>
```

This program is free software: you can redistribute it and/or modify it under the terms of the GNU General Public License as published by the Free Software Foundation, either version 3 of the License, or (at your option) any later version.

This program is distributed in the hope that it will be useful, but WITHOUT ANY WARRANTY; without even the implied warranty of MERCHANTABILITY or FITNESS FOR A PARTICULAR PURPOSE. See the GNU General Public License for more details.

You should have received a copy of the GNU General Public License along with this program. If not, see <http://www.gnu.org/licenses/>.

Also add information on how to contact you by electronic and paper mail.

If the program does terminal interaction, make it output a short notice like this when it starts in an interactive mode:

```
<program> Copyright (C) <year> <name of author>
This program comes with ABSOLUTELY NO WARRANTY; for details type `show
w'.
This is free software, and you are welcome to redistribute it
under certain conditions; type `show c' for details.
```

The hypothetical commands `show w' and `show c' should show the appropriate parts of the General Public License. Of course, your program's commands might be different; for a GUI interface, you would use an "about box".

You should also get your employer (if you work as a programmer) or school, if any, to sign a "copyright disclaimer" for the program, if necessary. For more information on this, and how to apply and follow the GNU GPL, see <http://www.gnu.org/licenses/>.

The GNU General Public License does not permit incorporating your program into proprietary programs. If your program is a subroutine library, you may consider it more useful to permit linking proprietary applications with the library. If this is what you want to do, use the GNU Lesser General Public License instead of this License. But first, please read

```
<http://www.gnu.org/philosophy/why-not-lgpl.html>.
```

27.15 ZedGraph — LGPL License

For easy distribution, this archive provides the dll form of ZedGraph only. This distribution of the ZedGraph source code includes two versions:

Version 4.6.x is the .Net 1.1 compatible version

Version 5.1.x is the .Net 2.0 compatible version

Complete source code for ZedGraph is available on sourceforge here:

<http://sourceforge.net/projects/zedgraph/>

A wiki providing help, samples, etc. is available here:

<http://zedgraph.org>

A tutorial on using ZedGraph is available here:

<http://www.codeproject.com/csharp/zedgraph.asp>

GNU LESSER GENERAL PUBLIC LICENSE
Version 2.1, February 1999

Copyright (C) 1991, 1999 Free Software Foundation, Inc.

59 Temple Place, Suite 330, Boston, MA 02111-1307 USA

Everyone is permitted to copy and distribute verbatim copies of this license document, but changing it is not allowed.

[This is the first released version of the Lesser GPL. It also counts as the successor of the GNU Library Public License, version 2, hence the version number 2.1.]

Preamble

The licenses for most software are designed to take away your freedom to share and change it. By contrast, the GNU General Public Licenses are intended to guarantee your freedom to share and change free software--to make sure the software is free for all its users.

This license, the Lesser General Public License, applies to some specially designated software packages--typically libraries--of the Free Software Foundation and other authors who decide to use it. You can use it too, but we suggest you first think carefully about whether this license or the ordinary General Public License is the better strategy to use in any particular case, based on the explanations below.

When we speak of free software, we are referring to freedom of use, not price. Our General Public Licenses are designed to make sure that you have the freedom to distribute copies of free software (and charge for this service if you wish); that you receive source code or can get it if you want it; that you can change the software and use pieces of it in new free programs; and that you are informed that you can do these things.

To protect your rights, we need to make restrictions that forbid distributors to deny you these rights or to ask you to surrender these rights. These restrictions translate to certain responsibilities for you if you distribute copies of the library or if you modify it.

For example, if you distribute copies of the library, whether gratis or for a fee, you must give the recipients all the rights that we gave you. You must make sure that they, too, receive or can get the source code. If you link other code with the library, you must provide complete object files to the recipients, so that they can relink them with the library after making changes to the library and recompiling it. And you must show them these terms so they know their rights.

We protect your rights with a two-step method: (1) we copyright the library, and (2) we offer you this license, which gives you legal permission to copy, distribute and/or modify the library.

To protect each distributor, we want to make it very clear that there is no warranty for the free library. Also, if the library is modified by someone else and passed on, the recipients should know that what they have is not the original version, so that the original author's reputation will not be affected by problems that might be introduced by others.

Finally, software patents pose a constant threat to the existence of any free program. We wish to make sure that a company cannot effectively restrict the users of a free program by obtaining a restrictive license from a patent holder. Therefore, we insist that any patent license obtained for a version of the library must be consistent with the full freedom of use specified in this license.

Most GNU software, including some libraries, is covered by the ordinary GNU General Public License. This license, the GNU Lesser General Public License, applies to certain designated libraries, and is quite different from the ordinary General Public License. We use this license for certain libraries in order to permit linking those libraries into non-free programs.

When a program is linked with a library, whether statically or using a shared library, the combination of the two is legally speaking a combined work, a derivative of the original library. The ordinary General Public License therefore permits such linking only if the Public License permits more lax criteria for linking other code with the library.

We call this license the "Lesser" General Public License because it does Less to protect the user's freedom than the ordinary General of an advantage over competing non-free programs. These disadvantages are the reason we use the ordinary General Public License for many libraries. However, the Lesser license provides advantages in certain special circumstances.

For example, on rare occasions, there may be a special need to encourage the widest possible use of a certain library, so that it becomes a de-facto standard. To achieve this, non-free programs must be allowed to use the library. A more frequent case is that a free library does the same job as widely used non-free libraries. In this case, there is little to gain by limiting the free library to free software only, so we use the Lesser General Public License.

In other cases, permission to use a particular library in non-free programs enables a greater number of people to use a large body of free software. For example, permission to use the GNU C Library in non-free programs enables many more people to use the whole GNU operating system, as well as its variant, the GNU/Linux operating system.

Although the Lesser General Public License is Less protective of the users' freedom, it does ensure that the user of a program that is linked with the Library has the freedom and the wherewithal to run that program using a modified version of the Library.

The precise terms and conditions for copying, distribution and modification follow. Pay close attention to the difference between a "work based on the library" and a "work that uses the library". The former contains code derived from the library, whereas the latter must be combined with the library in order to run.

GNU LESSER GENERAL PUBLIC LICENSE

TERMS AND CONDITIONS FOR COPYING, DISTRIBUTION AND MODIFICATION

0. This License Agreement applies to any software library or other program which contains a notice placed by the copyright holder or other authorized party saying it may be distributed under the terms of this Lesser General Public License (also called "this License"). Each licensee is addressed as "you".

A "library" means a collection of software functions and/or data prepared so as to be conveniently linked with application programs (which use some of those functions and data) to form executables.

The "Library", below, refers to any such software library or work which has been distributed under these terms. A "work based on the Library" means either the Library or any derivative work under copyright law: that is to say, a work containing the Library or a portion of it, either verbatim or

with modifications and/or translated straightforwardly into another language. (Hereinafter, translation is included without limitation in the term "modification".)

"Source code" for a work means the preferred form of the work for making modifications to it. For a library, complete source code means all the source code for all modules it contains, plus any associated interface definition files, plus the scripts used to control compilation and installation of the library.

Activities other than copying, distribution and modification are not covered by this License; they are outside its scope. The act of running a program using the Library is not restricted, and output from such a program is covered only if its contents constitute a work based on the Library (independent of the use of the Library in a tool for and what the program that uses the Library does.

1. You may copy and distribute verbatim copies of the Library's complete source code as you receive it, in any medium, provided that you conspicuously and appropriately publish on each copy an appropriate copyright notice and disclaimer of warranty; keep intact all the notices that refer to this License and to the absence of any warranty; and distribute a copy of this License along with the Library.

You may charge a fee for the physical act of transferring a copy, and you may at your option offer warranty protection in exchange for a fee.

2. You may modify your copy or copies of the Library or any portion of it, thus forming a work based on the Library, and copy and distribute such modifications or work under the terms of Section 1 above, provided that you also meet all of these conditions:

- a) The modified work must itself be a software library.
- b) You must cause the files modified to carry prominent notices stating that you changed the files and the date of any change.
- c) You must cause the whole of the work to be licensed at no charge to all third parties under the terms of this License.
- d) If a facility in the modified Library refers to a function or a table of data to be supplied by an application program that uses the facility, other than as an argument passed when the facility is invoked, then you must make a good faith effort to ensure that, in the event an application does not supply such function or table, the facility still operates, and performs whatever part of its purpose remains meaningful.

(For example, a function in a library to compute square roots has a purpose that is entirely well-defined independent of the application.

Therefore, Subsection 2d requires that any application-supplied function or table used by this function must be optional: if the application does not supply it, the square root function must still compute square roots.)

These requirements apply to the modified work as a whole. If identifiable sections of that work are not derived from the Library, and can be reasonably considered independent and separate works in themselves, then this License, and its terms, do not apply to those sections when you distribute them as separate works. But when you distribute the same sections as part of a whole which is a work based on the Library, the distribution of the whole must be on the terms of this License, whose permissions for other licensees extend to the entire whole, and thus to each and every part regardless of who wrote it.

Thus, it is not the intent of this section to claim rights or contest your rights to work written entirely by you; rather, the intent is to exercise the right to control the distribution of derivative or collective works based on the Library.

In addition, mere aggregation of another work not based on the Library with the Library (or with a work based on the Library) on a volume of a storage or distribution medium does not bring the other work under the scope of this License.

3. You may opt to apply the terms of the ordinary GNU General Public License instead of this License to a given copy of the Library. To do this, you must alter all the notices that refer to this License, so that they refer to the ordinary GNU General Public License, version 2, instead of to this License. (If a newer version than version 2 of the ordinary GNU General Public License has appeared, then you can specify that version instead if you wish.) Do not make any other change in these notices.

Once this change is made in a given copy, it is irreversible for that copy, so the ordinary GNU General Public License applies to all subsequent copies and derivative works made from that copy.

This option is useful when you wish to copy part of the code of the Library into a program that is not a library.

4. You may copy and distribute the Library (or a portion or under the terms of Sections 1 and 2 above provided that you accompany it with the complete corresponding machine-readable source code, which must be distributed under the terms of Sections 1 and 2 above on a medium customarily used for software interchange.

If distribution of object code is made by offering access to copy source code from the same place satisfies the requirement to distribute the source code, even though third parties are not compelled to copy the source along with the object code.

5. A program that contains no derivative of any portion of the Library, but is designed to work with the Library by being compiled or inked with it, is called a "work that uses the Library". Such a work, in isolation, is not a derivative work of the Library, and therefore falls outside the scope of this License.

However, linking a "work that uses the Library" with the Library creates an executable that is a derivative of the Library (because it contains portions of the Library), rather than a "work that uses the library". The executable is therefore covered by this License. Section 6 states terms for distribution of such executables.

When a "work that uses the Library" uses material from a header file that is part of the Library, the object code for the work may be a derivative work of the Library even though the source code is not. Whether this is true is especially significant if the work can be linked without the Library, or if the work is itself a library. The threshold for this to be true is not precisely defined by law.

If such an object file uses only numerical parameters, data structure layouts and accessors, and small macros and small inline functions (ten lines or less in length), then the use of the object file is unrestricted, regardless of whether it is legally a derivative work. (Executables containing this object code plus portions of the Library will still fall under Section 6.)

Otherwise, if the work is a derivative of the Library, you may distribute the object code for the work under the terms of Section 6. Any executables containing that work also fall under Section 6, whether or not they are linked directly with the Library itself.

6. As an exception to the Sections above, you may also combine or link a "work that uses the Library" with the Library to produce a work containing portions of the Library, and distribute that work under terms of your choice, provided that the terms permit modification of the work for the customer's own use and reverse engineering for debugging such modifications.

You must give prominent notice with each copy of the work that the Library is used in it and that the Library and its use are covered by this License. You must supply a copy of this License. If the work during execution displays copyright notices, you must include the copyright notice for the Library among them, as well as a reference directing the user to the copy of this License. Also, you must do one of these things:

a) Accompany the work with the complete corresponding machine-readable source code for the Library including whatever changes were used in the work (which must be distributed under Sections 1 and 2 above); and, if the work is an executable linked with the Library, with the complete machine-readable "work that uses the Library", as object code and/or source code, so that the

user can modify the Library and then relink to produce a modified executable containing the modified Library. (It is understood that the user who changes the contents of definitions files in the Library will not necessarily be able to recompile the application to use the modified definitions.)

b) Use a suitable shared library mechanism for linking with the Library. A suitable mechanism is one that (1) uses at run time a copy of the library already present on the user's computer system, rather than copying library functions into the executable, and (2) will operate properly with a modified version of the library, if the user installs one, as long as the modified version is interface-compatible with the version that the work was made with.

c) Accompany the work with a written offer, valid for at least three years, to give the same user the materials specified in Subsection 6a, above, for a charge no more than the cost of performing this distribution.

d) If distribution of the work is made by offering access to copy from a designated place, offer equivalent access to copy the above specified materials from the same place.

e) Verify that the user has already received a copy of these materials or that you have already sent this user a copy.

For an executable, the required form of the "work that uses the Library" must include any data and utility programs needed for reproducing the executable from it. However, as a special exception, the materials to be distributed need not include anything that is normally distributed (in either source or binary form) with the major components (compiler, kernel, and so on) of the operating system on which the executable runs, unless that component itself accompanies the executable.

It may happen that this requirement contradicts the license restrictions of other proprietary libraries that do not normally accompany the operating system. Such a contradiction means you cannot use both them and the Library together in an executable that you distribute.

7. You may place library facilities that are a work based on the Library side-by-side in a single library together with other library facilities not covered by this License, and distribute such a combined library, provided that the separate distribution of the work based on the Library and of the other library facilities is otherwise permitted, and provided that you do these two things:

a) Accompany the combined library with a copy of the same work based on the Library, uncombined with any other library facilities. This must be distributed under the terms of the Sections above.

b) Give prominent notice with the combined library of the fact that part of it is a work based on the Library, and explaining where to find the

accompanying uncombined form of the same work.

8. You may not copy, modify, sublicense, link with, or distribute the Library except as expressly provided under this License. Any attempt otherwise to copy, modify, sublicense, link with, or distribute the Library is void, and will automatically terminate your rights under this License. However, parties who have received copies, or rights, from you under this License will not have their licenses terminated so long as such parties remain in full compliance.

9. You are not required to accept this License, since you have not signed it. However, nothing else grants you permission to modify or distribute the Library or its derivative works. These actions are prohibited by law if you do not accept this License. Therefore, by modifying or distributing the Library (or any work based on the Library), you indicate your acceptance of this License to do so, and all its terms and conditions for copying, distributing or modifying the Library or works based on it.

10. Each time you redistribute the Library (or any work based on the Library), the recipient automatically receives a license from the original licensor to copy, distribute, link with or modify the Library subject to these terms and conditions. You may not impose any further restrictions on the recipients' exercise of the rights granted herein. You are not responsible for enforcing compliance by third parties with this License.

11. If, as a consequence of a court judgment or allegation of patent infringement or for any other reason (not limited to patent issues), conditions are imposed on you (whether by court order, agreement or otherwise) that contradict the conditions of this License, they do not excuse you from the conditions of this License. If you cannot distribute so as to satisfy simultaneously your obligations under this License and any other pertinent obligations, then as a consequence you may not distribute the Library at all. For example, if a patent license would not permit royalty-free redistribution of the Library by all those who receive copies directly or indirectly through you, then the only way you could satisfy both it and this License would be to refrain entirely from distribution of the Library.

If any portion of this section is held invalid or unenforceable under any particular circumstance, the balance of the section is intended to apply, and the section as a whole is intended to apply in other circumstances.

It is not the purpose of this section to induce you to infringe any patents or other property right claims or to contest validity of any such claims; this section has the sole purpose of protecting the integrity of the free software distribution system which is implemented by public license practices. Many people have made generous contributions to the wide range of software distributed through that system in reliance on consistent application of that system; it is up to the author/donor to decide if he or she is willing to distribute software through any other system and a licensee

cannot impose that choice.

This section is intended to make thoroughly clear what is believed to be a consequence of the rest of this License.

12. If the distribution and/or use of the Library is restricted in certain countries either by patents or by copyrighted interfaces, the original copyright holder who places the Library under this License may add an explicit geographical distribution limitation excluding those countries, so that distribution is permitted only in or among countries not thus excluded. In such case, this License incorporates the limitation as if written in the body of this License.

13. The Free Software Foundation may publish revised and/or new versions of the Lesser General Public License from time to time. but may differ in detail to address new problems or concerns.

Each version is given a distinguishing version number. If the Library specifies a version number of this License which applies to it and "any later version", you have the option of following the terms and conditions either of that version or of any later version published by the Free Software Foundation. If the Library does not specify a license version number, you may choose any version ever published by the Free Software Foundation.

14. If you wish to incorporate parts of the Library into other free programs whose distribution conditions are incompatible with these, write to the author to ask for permission. For software which is copyrighted by the Free Software Foundation, write to the Free Software Foundation; we sometimes make exceptions for this. Our decision will be guided by the two goals of preserving the free status of all derivatives of our free software and of promoting the sharing and reuse of software generally.

NO WARRANTY

15. BECAUSE THE LIBRARY IS LICENSED FREE OF CHARGE, THERE IS NO WARRANTY FOR THE LIBRARY, TO THE EXTENT PERMITTED BY APPLICABLE LAW. EXCEPT WHEN OTHERWISE STATED IN WRITING THE COPYRIGHT HOLDERS AND/OR OTHER PARTIES PROVIDE THE LIBRARY "AS IS" WITHOUT WARRANTY OF ANY KIND, EITHER EXPRESSED OR IMPLIED, INCLUDING, BUT NOT LIMITED TO, THE IMPLIED WARRANTIES OF MERCHANTABILITY AND FITNESS FOR A PARTICULAR PURPOSE. THE ENTIRE RISK AS TO THE QUALITY AND PERFORMANCE OF THE LIBRARY IS WITH YOU. SHOULD THE LIBRARY PROVE DEFECTIVE, YOU ASSUME THE COST OF ALL NECESSARY SERVICING, REPAIR OR CORRECTION.

16. IN NO EVENT UNLESS REQUIRED BY APPLICABLE LAW OR AGREED TO IN WRITING WILL ANY COPYRIGHT HOLDER, OR ANY OTHER PARTY WHO MAY MODIFY AND/OR REDISTRIBUTE THE LIBRARY AS PERMITTED ABOVE, BE LIABLE TO YOU FOR DAMAGES, INCLUDING ANY GENERAL, SPECIAL, INCIDENTAL OR CONSEQUENTIAL DAMAGES ARISING OUT OF THE USE OR INABILITY TO USE THE LIBRARY (INCLUDING BUT NOT LIMITED TO

LOSS OF DATA OR DATA BEING RENDERED INACCURATE OR LOSSES SUSTAINED BY YOU OR THIRD PARTIES OR A FAILURE OF THE LIBRARY TO OPERATE WITH ANY OTHER SOFTWARE), EVEN IF SUCH HOLDER OR OTHER PARTY HAS BEEN ADVISED OF THE POSSIBILITY OF SUCH DAMAGES.

END OF TERMS AND CONDITIONS

How to Apply These Terms to Your New Libraries

If you develop a new library, and you want it to be of the greatest possible use to the public, we recommend making it free software that everyone can redistribute and change. You can do so by permitting redistribution under these terms (or, alternatively, under the terms of the ordinary General Public License).

To apply these terms, attach the following notices to the library. It is safest to attach them to the start of each source file to most effectively convey the exclusion of warranty; and each file should have at least the "copyright" line and a pointer to where the full notice is found.

```
<one line to give the library's name and a brief idea of what it does.>
Copyright (C) <year> <name of author>
```

This library is free software; you can redistribute it and/or modify it under the terms of the GNU Lesser General Public License as published by the Free Software Foundation; either version 2.1 of the License, or (at your option) any later version.

This library is distributed in the hope that it will be useful, but WITHOUT ANY WARRANTY; without even the implied warranty of MERCHANTABILITY or FITNESS FOR A PARTICULAR PURPOSE. See the GNU Lesser General Public License for more details.

You should have received a copy of the GNU Lesser General Public License along with this library; if not, write to the Free Software Foundation, Inc., 59 Temple Place, Suite 330, Boston, MA 02111-1307 USA

Also add information on how to contact you by electronic and paper mail.

You should also get your employer (if you work as a programmer) or your school, if any, to sign a "copyright disclaimer" for the library, if necessary. Here is a sample; alter the names:

```
Yoyodyne, Inc., hereby disclaims all copyright interest in the library
`Frob' (a library for tweaking knobs) written by James Random Hacker.
```

```
<signature of Ty Coon>, 1 April 1990
Ty Coon, President of Vice
```

That's all there is to it!

27.16 Zlib1.dll — BSD License

zlib1.dll

Copyright © 1995-2004 Jean-loup Gailly and Mark Adler

This software is provided 'as-is', without any express or implied warranty. In no event will the authors be held liable for any damages arising from the use of this software.

Permission is granted to anyone to use this software for any purpose, including commercial applications, and to alter it and redistribute it freely, subject to the following restrictions:

1. The origin of this software must not be misrepresented; you must not claim that you wrote the original software. If you use this software in a product, an acknowledgment in the product documentation would be appreciated but is not required.
2. Altered source versions must be plainly marked as such, and must not be misrepresented as being the original software.
3. This notice may not be removed or altered from any source distribution.

Jean-loup Gailly
jloup@gzip.org

Mark Adler
madler@alumni.caltech.edu

If you use the zlib library in a product, we would appreciate *not* receiving lengthy legal documents to sign. The sources are provided for free but without warranty of any kind. The library has been entirely written by Jean-loup Gailly and Mark Adler; it does not include third-party code.

If you redistribute modified sources, we would appreciate that you include in the file ChangeLog history information documenting your changes. Please read the FAQ for more information on the distribution of modified source versions.

Support and Services

About Kollmorgen

When you need motion and automation systems for your most demanding applications and environments, count on Kollmorgen - the innovation leader for more than 100 years. We deliver the industry's highest-performing, most reliable motors, drives, AGV control solutions and automation platforms, with over a million standard and easily modifiable products to meet virtually any motion challenge. We offer manufacturing facilities, distributors and engineering expertise in all major regions around the world, so you can bring a better machine to market faster and keep it profitable for many years to come.

Kollmorgen Developer Network



Join the [Kollmorgen Support Network](#) for product support.

Ask the community questions, search the knowledge base for answers, get downloads, and suggest improvements.



Kollmorgen Support Locations

North America

Kollmorgen

201 West Rock Road
Radford, VA 24141, USA

Web: www.kollmorgen.com
Email: support@kollmorgen.com
Tel.: +1-540-633-3545
Fax: +1-540-639-4162

Europe

Kollmorgen Europe GmbH

Pempelfurtstr. 1
40880 Ratingen, Germany

Web: www.kollmorgen.com
Email: technik@kollmorgen.com
Tel.: +49-2102-9394-0
Fax: +49-2102-9394-3155

South America

Altra Industrial Motion do Brasil

Equipamentos Industriais LTDA.
Avenida João Paulo Ablas, 2970
Jardim da Glória, Cotia – SP
CEP 06711-250, Brazil

Web: www.kollmorgen.com
Email: contato@kollmorgen.com
Tel.: (+55 11) 4615-6300

China and SEA

KOLLMORGEN

Room 302, Building 5, Libao Plaza,
88 Shenbin Road, Minhang District,
Shanghai, China.

Web: www.kollmorgen.cn
Email: sales.china@kollmorgen.com
Tel.: +86-400 668 2802