

Kollmorgen Automation Suite

KAS - PLC Library Reference Guide



Document Edition: BB, December 2024

Valid for KAS Software Revision 4.03

Part Number: 959717



For safe and proper use, follow these instructions.
Keep for future use.

Copyrights, Licenses, and Trademarks

PCMM2G

The PCMM2G's Operating System (OS) and boot loader ([U-Boot](#)) are based on free and open-source software, distributed under version 3 of the GNU General Public License as published by the Free Software Foundation. For more information about your rights and obligations with GPL-3.0, see the GNU website: [GNU General Public License](#).

The individual copyright notices, license texts, and disclaimers of warranty for the software components are located in the controller, under the directory: `/usr/share/common-licenses/`.

For more information about accessing the PCMM2G's files, see [SSH Login to a Controller](#).

The OS, bootloader, and their software component's source codes including modifications, copyright notices, license texts, disclaimers of warranty, and the compilation scripts to build the OS image are available from the Kollmorgen web-site [Kollmorgen Support Network - Downloads](#).

The OS image and its corresponding sources file is identified by an "OS-Sources" designator, followed by its version number: OS-Sources-x.xx.x.xxxxx.

The compilation scripts and sources file used to build the OS image is identified by the "OS-Build-Sources" designator, followed by its version number: OS-Build-Sources-x.xx.x.xxxxx.

See [PCMM2G - File Naming Conventions](#) in the KAS online help.

Copyrights

Copyright © 2009-2024 Regal Rexnord Corporation, All Rights Reserved.

Information in this document is subject to change without notice.

The software package described in this document is furnished under a license agreement. The software package may be used or copied only in accordance with the terms of the license agreement.

Trademarks

Regal Rexnord and [Kollmorgen](#) are trademarks of [Regal Rexnord Corporation](#) or one of its affiliated companies.

- KAS and AKD are registered trademarks of [Kollmorgen](#).
- EnDat® is a registered trademark of Dr. Johannes Heidenhain GmbH.
- EtherCAT is a registered trademark and patented technology, licensed by Beckhoff Automation GmbH.
- Ethernet/IP Communication Stack: copyright (c) 2009, Rockwell Automation.
- Ethernet/IP is a registered trademark of ODVA, Inc.
- [Ghostscript](#) is a registered trademark of Artifex Software, Inc. and is distributed under the [AGPL](#) license.
- HIPERFACE® is a registered trademark of Max Stegmann GmbH.
- [PLCopen](#) is an independent association providing efficiency in industrial automation.
- PROFINET® is a registered trademark of PROFIBUS and PROFINET International (PI).
- SIMATIC® is a registered trademark of SIEMENS AG.
- SyCon® is a registered trademark of [Hilscher GmbH](#).
- Windows® is a registered trademark of Microsoft Corporation.

Kollmorgen Automation Suite is based on the work of:

- [7-zip](#) (distributed under the terms of the LGPL and the BSD 3-clause licenses - [7-zip - License](#))
- [C++ Mathematical Expression Library](#) (distributed under the [MIT License](#))
- [civetweb: Embedded C/C++ web server](#) software (distributed under [MIT License](#))
- [curl](#) software library
- [jsoncpp](#) software (distributed under the MIT License - see [jsoncpp License](#))
- [Mongoose](#) software (distributed under the MIT License - see [Mongoose license](#))
- [Qt](#) cross-platform SDK (distributed under the [terms of the LGPL3](#); Qt source is available on KDN)
- [Qwt](#) project (distributed under the terms of the [Qwt - GNU Lesser General Public License](#))
- [U-Boot](#), a universal boot loader is used by the AKD PDMM and PCMM (distributed under the [terms](#) of the GNU General Public License). The U-Boot source files, copyright notice, and readme are available on the distribution disk that is included with the AKD PDMM and PCMM.
- [Zlib](#) software library

All other product and brand names listed in this document may be trademarks or registered trademarks of their respective owners.

Disclaimer

Technical changes which improve the performance of the device may be made without prior notice!

This document is the intellectual property of Kollmorgen. All rights reserved. No part of this work may be reproduced in any form (by photocopying, microfilm or any other method) or stored, processed, copied or distributed by electronic means without the written permission of Kollmorgen.

The information in this document is believed to be accurate and reliable at the time of its release. Kollmorgen assumes no responsibility for any damage or loss resulting from the use of this help, and expressly disclaims any liability or damages for loss of data, loss of use, and property damage of any kind, direct, incidental or consequential, in regard to or arising out of the performance or form of the materials presented herein or in any software programs that accompany this document.

All timing diagrams, whether produced by Kollmorgen or included by courtesy of the PLCopen organization, are provided with accuracy on a best-effort basis with no warranty, explicit or implied, by Kollmorgen. The user releases Kollmorgen from any liability arising out of the use of these timing diagrams.

Table of Contents

1 Programming Languages	11
1.1 Sequential Function Chart (SFC)	11
1.1.1 SFC Execution at Runtime	11
1.1.1.1 Divergence	12
1.1.1.1.1 Order of Action Block Execution	12
1.1.2 Hierarchy of SFC Programs	14
1.1.3 Control an SFC Child Program	14
1.2 Function Block Diagram (FBD)	15
1.2.1 Data Flow	15
1.2.2 FFLD Symbols	15
1.3 Instruction List (IL)	15
1.3.1 Comments	16
1.3.2 Data Flow	16
1.3.3 Evaluation of Expressions	16
1.3.4 Actions	17
1.4 Structured Text (ST)	18
1.4.1 Comments	18
1.4.2 Expressions	18
1.4.3 Statements	18
1.4.3.1 Basic Statements	18
1.4.3.2 Conditional Statements	19
1.4.3.3 Loop Statements	19
1.4.3.4 Other Statements	19
1.5 Constant Expressions	20
1.5.1 Examples	23
1.5.1.1 Valid Constant Expressions	23
1.5.1.2 Invalid Constant Expressions	23
1.6 Variables	24
1.6.1 Groups	24
1.6.2 Data Type and Dimension	25
1.6.3 Name a Variable	25
1.6.4 Variable Attributes	25
1.7 Free Form Ladder Diagram (FFLD)	25
1.7.1 Use of EN Input and ENO Output for Blocks	26
1.7.1.1 Examples	26
1.7.2 FFLD Contacts and Coils	27
1.7.2.1 FFLD Contacts	27
1.7.2.1.1 Serialized and Parallel Contacts	28
1.7.2.1.2 Transition Contacts	28
1.7.2.2 FFLD Coils	29
2 PLC Advanced Libraries	31
2.1 All Functions - Alphabetical	31
2.1.1 Alarm Management	32
2.1.2 Analog Signal Processing	32
2.1.3 Communication	32
2.1.4 Data Collections and Serialization	32

2.1.5 Data Log	32
2.1.6 Special Operations	33
2.2 AS-interface Functions	33
2.2.1 Interface	33
2.2.2 Arguments	33
2.3 File Management	34
2.3.1 Sequential Read / Write Function Blocks	34
2.3.2 SD card Functions	35
2.3.2.1 Related Function Blocks	35
2.3.3 SD Card Access	35
2.3.4 File Path Conventions	36
2.3.4.1 File Name Warning and Limitations	36
2.3.4.2 Shared Directory Path Conventions	37
2.3.4.3 SD Card Path Conventions	37
2.3.4.3.1 Valid Paths	38
2.3.4.3.2 Invalid Paths	38
2.3.4.4 USB Flash Drive Path Conventions	38
2.3.4.4.1 Valid Paths	38
2.3.4.4.2 Invalid Paths	39
2.4 PLC Advanced - Advanced	39
2.4.1 Alarm_A	40
2.4.1.0.1 Sequence	40
2.4.2 Alarm_M	41
2.4.2.0.1 Sequence	42
2.4.3 ApplyRecipeColumn	43
2.4.4 average / averageL	45
2.4.5 CurveLin	47
2.4.6 derivate	48
2.4.7 FIFO	49
2.4.8 FilterOrder1	51
2.4.8.0.1 Example	52
2.4.9 hyster	52
2.4.10 integral	54
2.4.11 LIFO	55
2.4.12 lim_alm	57
2.4.13 PWM	58
2.4.14 RAMP	60
2.4.15 rand	62
2.4.16 SerializeIn	62
2.4.17 SerializeOut	64
2.4.18 SigID	65
2.4.19 SigPlay	67
2.4.20 SigScale	68
2.4.21 stackint	69
2.4.22 SurfLin	71
2.4.23 VLID	72
2.5 PLC Advanced - Files	73
2.5.1 LogFileCSV	74

2.5.2 SD Card Mounting Functions	76
2.5.2.1 SD_ISREADY	76
2.5.2.2 SD_MOUNT	77
2.5.2.3 SD_UNMOUNT	77
2.6 PID	78
2.6.0.1 Diagram	79
3 PLC Standard Libraries	81
3.1 Programming Languages	81
3.2 Programming Features	81
3.3 Arithmetic Operations	81
3.3.1 All Functions and Operators (Alphabetically)	81
3.3.1.1 Standard Functions	82
3.3.1.2 Standard Operators	82
3.3.2 Addition +	82
3.3.3 Divide /	83
3.3.4 NEG -	85
3.3.5 limit	86
3.3.5.0.1 Function Diagram	86
3.3.6 max	87
3.3.7 min	88
3.3.8 mod / modLR / modR	90
3.3.9 Multiply	91
3.3.10 odd	92
3.3.11 SetWithin	93
3.3.12 Subtraction -	94
3.4 Basic Operations	96
3.4.1 Data Manipulation	96
3.4.2 Control Program Execution	96
3.4.2.1 Language Features	96
3.4.2.2 Structured Statements	96
3.4.3 Assignment :=	97
3.4.4 Bit Access	98
3.4.5 Differences between Functions and Function Blocks	98
3.4.6 Call a Sub-Program	99
3.4.6.1 FBD and FFLD Languages	99
3.4.7 CASE OF ELSE END_CASE	100
3.4.7.1 Syntax	100
3.4.8 EXIT	101
3.4.9 FOR TO BY END_FOR	102
3.4.9.1 Syntax	102
3.4.10 IF THEN ELSE ELSIF END_IF	103
3.4.10.1 Syntax	103
3.4.11 ON	104
3.4.11.1 Syntax	104
3.4.12 Parenthesis ()	105
3.4.13 REPEAT UNTIL END_REPEAT	106
3.4.13.1 Syntax	106
3.4.14 RETURN RET RETC RETNC RETCN	107

3.4.15 WAIT / WAIT_TIME	109
3.4.15.1 Syntax	109
3.4.16 WHILE DO END_WHILE	110
3.4.16.1 Syntax	110
3.5 Boolean Operations	111
3.5.1 All Functions (Alphabetically)	111
3.5.1.1 Standard Operators	111
3.5.1.2 Available Blocks	112
3.5.2 FlipFlop	112
3.5.3 f_trig	113
3.5.4 QOR	115
3.5.5 R	116
3.5.6 RS	117
3.5.7 r_trig	118
3.5.8 S	119
3.5.9 sema	121
3.5.10 SR	122
3.5.11 XOR / XORN	123
3.6 Clock Management Functions (Real Time)	125
3.6.1 All Functions (Alphabetically)	125
3.6.1.1 Format the Present Date / Time	126
3.6.1.2 Read the Real Time Clock	126
3.6.1.3 Time Zone and Clock Synchronization	126
3.6.1.4 Triggering Operations	127
3.6.2 day_time	127
3.6.3 DTAt	128
3.6.3.1 Inputs	128
3.6.3.2 Outputs	128
3.6.4 DTCurDate	130
3.6.5 DTCurDateTime	131
3.6.6 DTCurTime	133
3.6.7 DTDay	133
3.6.8 DTGetNTPServer	134
3.6.9 DTGetNTPSync	136
3.6.10 DTGetTimeZone	138
3.6.10.1 Inputs	138
3.6.10.2 Outputs	139
3.6.11 DTEvery	140
3.6.12 DTFormat	142
3.6.13 DTHour	143
3.6.14 DTListTimeZones	144
3.6.15 DTMake	146
3.6.16 DTMin	147
3.6.17 DTMonth	148
3.6.18 DTMs	149
3.6.19 DTSec	150
3.6.20 DTSetDateTime	151
3.6.21 DTSetNTPServer	153

3.6.22 DTSetNTPSync	155
3.6.23 DTSetTimeZone	157
3.6.24 DTYear	159
3.6.25 List of Date / Time / NTP ErrorID Codes	159
3.7 Comparison Operations	160
3.7.1 CMP	160
3.7.2 GE >=	161
3.7.3 GT >	163
3.7.4 EQ =	164
3.7.5 NE <>	165
3.7.6 LE <=	167
3.7.7 LT <	168
3.8 Conversion Functions	169
3.8.1 All Functions (Alphabetically)	170
3.8.1.1 Convert Data to Another Data Type	170
3.8.1.2 BCD Format Conversions	170
3.8.2 any_to_bool	171
3.8.3 any_to_dint / any_to_udint	172
3.8.4 any_to_int / any_to_uint	173
3.8.5 any_to_lint / any_to_ulint	174
3.8.6 any_to_lreal	176
3.8.7 any_to_real	177
3.8.7.1 Outputs	177
3.8.8 any_to_time	178
3.8.9 any_to_sint / any_to_usint	180
3.8.10 any_to_string	181
3.8.11 num_to_string	182
3.8.12 bcd_to_bin	183
3.8.13 bin_to_bcd	185
3.9 Counters	186
3.9.1 CTD / CTDr	186
3.9.2 CTU / CTUr	187
3.9.3 CTUD / CTUDr	189
3.9.3.1 Remarks	189
3.10 Mathematic Operations	190
3.10.1 abs / absL	191
3.10.2 expt	192
3.10.3 EXP / EXPL	193
3.10.4 log / logL	194
3.10.5 LN / LNL	195
3.10.6 pow / powL	196
3.10.7 root	198
3.10.7.1 FBD Language	198
3.10.8 ScaleLin	199
3.10.9 sqrt / sqrtL	200
3.10.10 trunc / truncL	202
3.11 Miscellaneous Functions	203
3.11.1 EnableEvents	203

3.11.2 GetSysInfo	204
3.12 Registers	206
3.12.1 All Register Functions (Alphabetically)	206
3.12.1.1 Advanced Function	206
3.12.1.2 Bit Access	207
3.12.1.3 Bit-to-Bit Functions	207
3.12.1.4 Pack / Unpack Functions	207
3.12.1.5 Standard Functions	207
3.12.2 and_mask	208
3.12.3 HiByte	209
3.12.4 LoByte	210
3.12.5 HiWord	211
3.12.6 LoWord	212
3.12.7 MakeDWord	213
3.12.8 MakeWord	215
3.12.9 MBSHift	216
3.12.10 not_mask	217
3.12.11 or_mask	218
3.12.12 Pack8	220
3.12.13 rol	221
3.12.14 ror	222
3.12.15 SetBit	225
3.12.16 shl	226
3.12.17 shr	227
3.12.18 SWAB	228
3.12.18.0.1 Examples	229
3.12.19 TestBit	230
3.12.20 Unpack8	231
3.12.21 xor_mask	232
3.13 Selectors	233
3.13.1 mux	234
3.13.1.0.1	234
3.13.1.0.2	235
3.13.2 mux4	235
3.13.2.0.1	236
3.13.3 mux8	237
3.13.3.0.1	237
3.13.4 mux64	238
3.13.4.0.1	239
3.13.5 sel	240
3.14 Standard Functions	242
3.14.1 CountOf	242
3.14.2 DEC	243
3.14.3 INC	244
3.14.4 MoveBlock	246
3.14.5 NEG -	247
3.14.6 NOT	248
3.15 String Operations	250

3.15.1 Character Strings	250
3.15.2 Manage String Tables	250
3.15.3 ArrayToString / ArrayToStringU	250
3.15.4 ascii	251
3.15.5 AToH	253
3.15.6 char	254
3.15.7 concat	255
3.15.8 CRC16	256
3.15.9 delete	257
3.15.10 find	258
3.15.11 HToA	260
3.15.12 insert	261
3.15.13 left	262
3.15.14 LoadString	264
3.15.15 mid	265
3.15.16 mlen	266
3.15.17 replace	267
3.15.18 right	269
3.15.19 StringTable	270
3.15.19.1 String Table Resources	271
3.15.20 StringToArray / StringToArrayU	272
3.16 Timers	273
3.16.1 blink	274
3.16.2 BlinkA	275
3.16.3 PLS	276
3.16.4 sig_gen	278
3.16.5 TMD	279
3.16.6 TMU / TMUsec	281
3.16.7 TOF / TOFR	282
3.16.8 TON	284
3.16.9 TP / TPR	285
3.17 Trigonometric Functions	287
3.17.1 acos / acosL	287
3.17.2 asin / asinL	288
3.17.3 atan / atanL	290
3.17.4 atan2 / atan2L	291
3.17.5 cos / cosL	292
3.17.6 sin / sinL	293
3.17.7 tan / tanL	294
3.17.7.1 Inputs	294
3.17.7.2 Outputs	294
3.17.8 UseDegrees	295
Support and Services	297

1 Programming Languages

This section provides information about the syntax, structure, and use of declarations and statements supported by the KAS-IDE application language.

These are the available programming languages of the IEC 61131-3 standard:

- "Free Form Ladder Diagram (FFLD)" (→ p. 25)
- "Function Block Diagram (FBD)" (→ p. 15)
- "Instruction List (IL)" (→ p. 15)
- "Sequential Function Chart (SFC)" (→ p. 11)
- "Structured Text (ST)" (→ p. 18)

A language must be selected for each program or User-Defined Function Block of the application.

NOTE

When using FBD or FFLD languages, review Use ST Expressions in Graphic Language.

1.1 Sequential Function Chart (SFC)

The SFC language is a state diagram.

- Graphical steps are used to represent stable states.
- Transitions describe the conditions and events that lead to a change of state.
- Using SFC simplifies the programming of sequential operations because it saves a lot of variables and tests just for maintaining the program context.

ⓘ IMPORTANT

Do not use SFC as a decision diagram.

Using a step as a point of decision and transitions as conditions in an algorithm must never appear in an SFC chart.

Using SFC as a decision language leads to poor performance and complicate charts.

ST must be preferred when programming a decision algorithm that has no sense in term of program state.

These are basic components of an SFC chart:

Chart	Programming
<ul style="list-style-type: none"> • SFC Steps • SFC Transitions • Create SFC Parallel Branches • Jump to an SFC Step 	<ul style="list-style-type: none"> • Actions in an SFC Step • Timeout on an SFC Step • Condition of an SFC Transition

The KAS-IDE fully supports SFC programming with several hierarchical levels of charts (e.g., a chart that controls another chart).

Working with a hierarchy of SFC charts is an easy and powerful way for managing complex sequences and saves performances at runtime.

See these sections for more information:

- "Hierarchy of SFC Programs" (→ p. 14)
- "Control an SFC Child Program" (→ p. 14)

1.1.1 SFC Execution at Runtime

SFC programs are executed sequentially within a target cycle according to the order defined when entering programs in the hierarchy tree.

- A parent SFC program is executed before its children.
 - This implies that when a parent starts or stops a child, the corresponding actions in the child program are performed during the same cycle.
- In a chart, all valid transitions are evaluated first and then actions of active steps are performed.
 - The chart is evaluated from the left to the right and from the top to the bottom.

Example

Execution order:



- Evaluate transitions:
 - 1, 101, 2
- Manage steps:
 - 1, 101, 201, 102
 - 3

The initial steps define the initial status of the program when it is started.

- All top level (main) programs are started when the application starts.
- Child programs are explicitly started from action blocks within the parent programs.

The evaluation of transitions leads to changes of active steps, according to these rules:

- A transition is crossed if:
 - Its condition is TRUE **and** all steps linked to the top of the transition (before) are active.
- When a transition is crossed:
 - All steps linked to the top of the transition (before) are deactivated.
 - All steps linked to the bottom of the transition (after) are activated.

1.1.1.1 Divergence

- All conditions are considered as **exclusive**, according to a left-to-right priority order.
 - It means a transition is considered as FALSE if at least one of the transitions connected to the same divergence on its left side is TRUE.

1.1.1.1.1 Order of Action Block Execution

For a given cycle, if a transition is:

- FALSE, the N-action blocks are evaluated for all active steps waiting on that transition.
- TRUE, the P0 action blocks are evaluated for all active steps waiting on that transition, followed by the P1 and N steps for all steps waiting on that transition.
 - The steps that were waiting on that transition are then marked as active.

Example

Using this SFC:

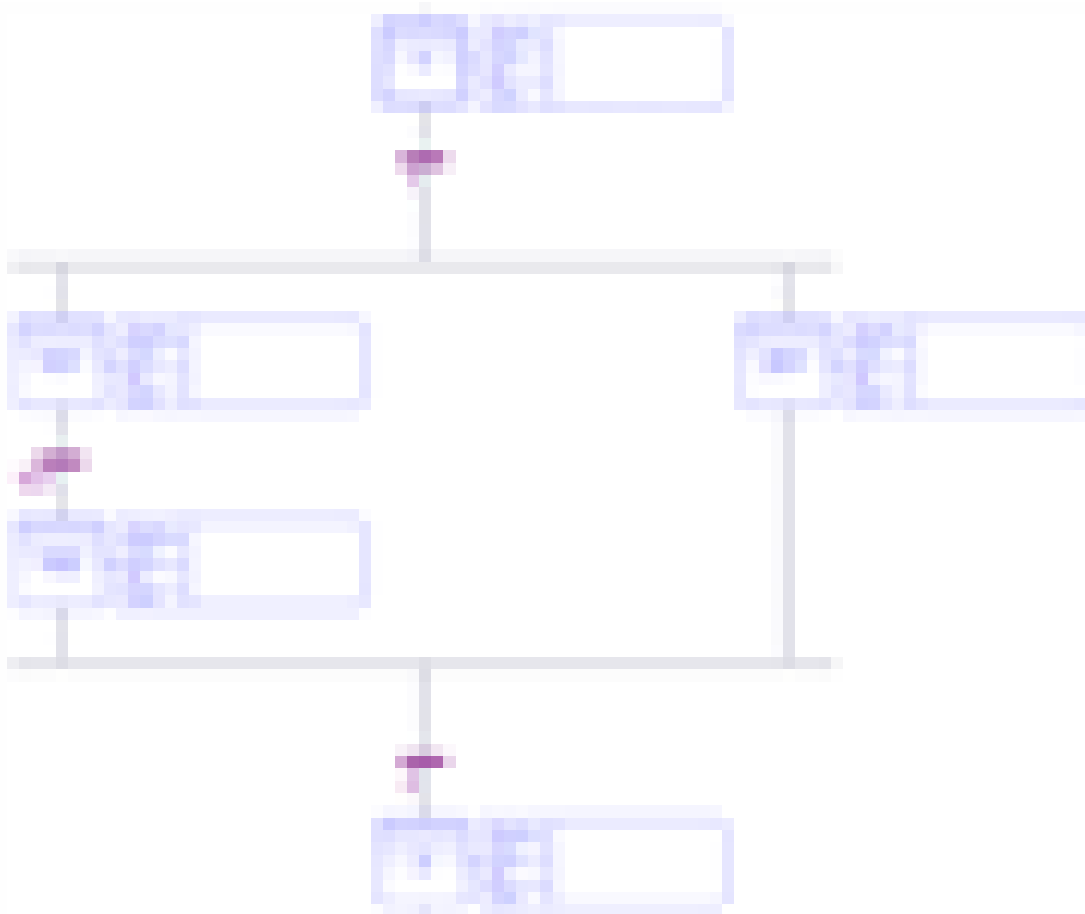

The order of action block execution for a given cycle is:

Incoming State	Evaluating Transition	If Transition is FALSE	If Transition is TRUE
First Cycle	N/A	[1] P1 [1] N	
Transition 1. Not yet TRUE.	Transition 1	[1] N	[1] P0 [101] P1 [101] N [201] P1 [201] N
Passed transition 1. Transition 101 not yet TRUE.	Transition 101	[101] N [201] N	[101] P0 [201] N [102] P1 [102] N
Passed transitions 1 and 101 Transition 2 not yet TRUE.	Transition 2	[201] N [102] N	[201] P0 [102] P0 [3] P1 [3] N

ⓘ IMPORTANT

Execution of SFC in the IEC 61131-3 target is sampled according to the target cycles. When a transition is crossed within a cycle, these steps are activated. The evaluation of the chart continues in the next cycle. If several consecutive transitions are TRUE within a branch, only one of them is crossed within one target cycle.

ⓘ IMPORTANT

Some runtime systems may not support exclusivity of the transitions within an divergence. See the OEM instructions for more information about SFC support.

1.1.2 Hierarchy of SFC Programs

Each SFC program can have one or more child programs.

- Child programs are written in SFC.
- They are started or stopped in the actions of the parent program.
- The number of hierarchy levels must not exceed 19.
- A child program can also have children.
 - When a child program is stopped, its children are also stopped.
 - When a child program is started, it must start its children.
 - A child program is controlled (started or stopped) from the action blocks of its parent program.
 - Designing a child program is:
 - a simple way to program an action block in SFC language.
 - very useful for designing a complex process and separate operations due to different aspects of the process.
 - Example: It is common to manage the execution modes in a parent program and to handle details of the process operations in child programs.

1.1.3 Control an SFC Child Program

Controlling a child program can be simply achieved by specifying the name of the child program as an action block in a step of its parent program.

These are possible qualifiers that can be applied to an action block for handling a child program:

Child (N);	Starts the child program when the step is activated and stops (kills) it when the step is deactivated.
Child (S);	Starts the child program when the step is activated. Initial steps of the child program are activated.
Child (R);	Stops (kills) the child program when the step is activated. All active steps of the child program are deactivated.

Alternatively, use these statements in an action block programmed in ST language.

In this table, "prog" represents the name of the child program:

GSTART (prog);	Starts the child program when the step is activated. Initial steps of the child program are activated.
GKILL (prog);	Stops (kills) the child program when the step is activated. All active steps of the child program are deactivated.
GFREEZE (prog);	Suspends the execution of a child program.
GRST (prog);	Restarts a program suspended by a GFREEZE command.

Use the GSTATUS function in expressions.

This function returns the current state of a child SFC program:

GSTATUS (prog)	Returns the current state of a child SFC program: 0: program is inactive 1: program is active 2: program is suspended
----------------	--

NOTE

When a child program is started by its parent program, it keeps the "inactive" status until it is executed (further in the cycle).

If a child program is started in an SFC chart, GSTATUS returns 1 (active) on the next cycle.

1.2 Function Block Diagram (FBD)

A function block diagram is a data flow between constant expressions or variables and operations represented by rectangular blocks.

- Operations can be basic operations, function calls, or function block calls.
- The name of the operation or function, or the type of function block is written within the block rectangle.
- With a function block call, the name of the called instance is written in the header of the block rectangle.

Example



1.2.1 Data Flow

- The data flow represents values of any data type.
 - All connections must be from input and outputs points having the same data type.
- With a Boolean connection, use a connection link terminated by a small circle.
 - This indicates a Boolean **negation** of the data flow.

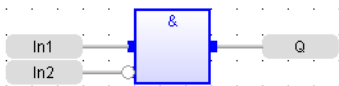

- The data flow must be understood from the left to the right and from the top to the bottom.
 - It is possible to use labels and jumps to change the default data flow execution.

1.2.2 FFLD Symbols

FFLD symbols can also be entered in FBD diagrams and linked to FBD objects.

- See these sections for information about components of the FFLD language:
 - "FFLD Coils" (→ p. 29)
 - "FFLD Contacts" (→ p. 27)
 - Power Rails
- Special vertical lines are available in FBD language for representing the merging of FFLD parallel lines.
 - Such vertical lines represent a **OR** operation between the connected inputs.

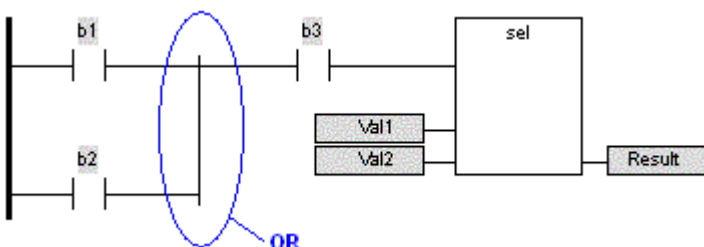

Figure 2-1: Example: OR Vertical Line used in an FBD Diagram

1.3 Instruction List (IL)

This language is more appropriate when your algorithm refers to the Boolean algebra.

A program written in IL language is a list of instructions.

- Each instruction is written on one line of text.
- An instruction can have one or more *operands*.
- Operands are variables or constant expressions.
- Each instruction begins with a label, followed by a colon (:).
- Labels are used as destination for jump instructions.

KAS-IDE allows you to mix ST and IL languages in textual program.

- ST Language is the default language.
- When you enter IL Language instructions, the program must be entered between `BEGIN_IL` and `END_IL` keywords.

Example

```
BEGIN_IL
FFLD var1
ST var2
END_IL
```

1.3.1 Comments

Comment text can be entered at the end of a line containing an instruction.

- Comment texts have no meaning for the execution of the program.
- Comment text must begin with `(*` and end with `*)`.
- Comments can be entered on empty lines (with no instruction) and on several lines (i.e., a comment text can include line breaks).
- Comment texts cannot be nested.

```
( * My comment * )
LD a
ST b (* Store value in d *)
```

1.3.2 Data Flow

An IL Language complete statement is made of instructions for:

- first: evaluating an expression (called current result).
- then: use the current result for performing actions.

1.3.3 Evaluation of Expressions

The order of instructions in the program is the one used for evaluating expressions, unless parentheses are inserted.

This list is the available instructions for evaluation of expressions:

Instruction	Operand	Meaning
"Addition +" (→ p. 82)	Numerical	Performs an addition of all inputs. Adds the operand and the current result.
AND ANDN &	Boolean	Performs a logical AND of all inputs. AND between the operand and the current result.

Instruction	Operand	Meaning
"Divide /" (→ p. 83)	Numerical	Performs a division of all inputs. Divide the current result by the operand.
"EQ =" (→ p. 164)	Numerical	Test if the first input is equal to the second input. Compares the current result with the operand.
"Assignment :=" (→ p. 97)	Any type	Loads the operand in the current result.
Function Call	Functional Arguments	Calls a function.
"GE >=" (→ p. 161)	Numerical	Tests if the first input is greater than or equal to the second input. Compares the current result with the operand.
"GT >" (→ p. 163)	Numerical	Test if the first input is greater than the second input. Compares the current result with the operand.
"LE <=" (→ p. 167)	Numerical	Test if the first input is less than or equal to the second input. Compares the current result with the operand.
"LT <" (→ p. 168)	Numerical	Test if the first input is less than the second input. Compares the current result with the operand.
"Multiply" (→ p. 91)	Numerical	Performs a multiplication of all inputs. Multiply the operand and the current result.
"NE <>" (→ p. 165)	Numerical	Test if the first input is not equal to the second input. Compares the current result with the operand.
OR / ORN	Boolean	Performs a logical OR of all inputs. OR between the operand and the current result.
"Parenthesis ()" (→ p. 105)		Changes the execution order.
"Subtraction -" (→ p. 94)	Numerical	Performs a subtraction of all inputs. Subtract the operand from the current result.
"XOR / XORN" (→ p. 123)	Boolean	XOR between the operand and the current result.

NOTE

Instructions suffixed by **N** use the Boolean negation of the operand.

1.3.4 Actions

These instructions perform actions according to the value of current result.

Some of these instructions do not need a current result to be evaluated.

Instruction	Operand	Meaning
CAL	f. block	Calls a function block (no current result needed).
CALC	f. block	Calls a function block if the current result is TRUE.
CALNC / CALCN	f. block	Calls a function block if the current result is FALSE.
JMP	label	Jump to a label - no current result needed.
JMPC	label	Jump to a label if the current result is TRUE.

Instruction	Operand	Meaning
JMPNC / JMPCN	label	Jump to a label if the current result is FALSE.
<u>R</u>	Boolean	Sets the operand to FALSE if the current result is TRUE.
<u>RET</u>		Jump to the end of the current program - no current result needed.
<u>RETC / RETNC / RETCN</u>		Jump to the end of the current program if the current result is TRUE / FALSE.
<u>S</u>	Boolean	Sets the operand to TRUE if the current result is TRUE.
<u>ST / STN</u>	Any type	Stores the current result in the operand.

NOTE

Instructions suffixed by **N** use the Boolean negation of the operand.

NOTE

An IL Language program cannot be called if there is no entry variable or if it's type is complex (e.g., array).

1.4 Structured Text (ST)

ST is a structured literal programming language.

- A ST program is a list of statements.
 - Each statement describes an action and must end with a semi-colon (;).
- The presentation of the text has no meaning for a ST program.
 - You can insert blank characters and line breaks where you want in the program text.

1.4.1 Comments

Comment text can be entered anywhere in an ST program.

- Comment text:
 - Has no meaning for the execution of the program.
 - Must begin with (* and end with *) .
 - Can be entered on several lines (i.e., a comment text can include line breaks).
 - Cannot be nested.

1.4.2 Expressions

Each statement describes an action and can include evaluation of complex expressions.

An expression is evaluated:

- From the left to the right.
- According to the default priority order of operators.
 - The default priority can be changed using parentheses "Parenthesis ()" (→ p. 105).

Arguments of an expression can be:

- Declared "Variables" (→ p. 24).
- "Constant Expressions" (→ p. 20).
- Function Call.

1.4.3 Statements

1.4.3.1 Basic Statements

These are the available basic statements that can be entered in an ST program:

- "Assignment :=" (→ p. 97) (assignment)
- Call a Function Block

1.4.3.2 Conditional Statements

These are the available conditional statements in ST Language:

- "CASE OF ELSE END_CASE" (→ p. 100)
- "IF THEN ELSE ELSIF END_IF" (→ p. 103)

1.4.3.3 Loop Statements

These are the available statements for describing loops in ST Language:

- "FOR TO BY END_FOR" (→ p. 102)
 - Loops with FOR instructions are slow.
Optimize your code by replacing such iterations with a WHILE statement.

```
Iteration of statement execution.
The BY statement is optional (default value is 1)
FOR iCount := 0 TO 100 BY 2 DO
MyVar := MyVar + 1;
END_FOR;
```

- "REPEAT UNTIL END_REPEAT" (→ p. 106)

```
Repeat a list of statements.
Condition is evaluated on loop exit after the statements.
iCount := 0;
REPEAT
MyVar := MyVar + 1;
iCount := iCount + 1;
UNTIL iCount < 100 END_REPEAT;
```

- "WHILE DO END_WHILE" (→ p. 110)

```
Repeat a list of statements.
Condition is evaluated on loop entry before the statements.
iCount := 0;
WHILE iCount < 100 DO
iCount := iCount + 1;
MyVar := MyVar + 1;
END_WHILE;
```

1.4.3.4 Other Statements

These are some other statements in ST Language:

- "WAIT / WAIT_TIME" (→ p. 109) - Suspend the execution.
- "ON" (→ p. 104) - Conditional execution of statements: provides a simpler syntax for checking the rising edge of a Boolean condition.

TIP

ST provides an automatic completion of typed words.
See Auto-completion of Words for more information.

1.5 Constant Expressions

Constant expressions can be used in all languages for assigning a variable with a value.

All constant expressions have well-defined **Data Types** according to their semantics.

IMPORTANT

If you program an operation between variables and constant expressions having inconsistent data types, it leads to syntactic errors when the program is compiled.

These are the syntactic rules for constant expressions according to possible data types:

Type	Prefix	Description
BOOL		Boolean <ul style="list-style-type: none"> These are the Boolean reserved keywords: <ul style="list-style-type: none"> TRUE FALSE See "Valid Constant Expressions" (→ p. 23) for an example.
DINT		32-bit (default) Integer <ul style="list-style-type: none"> 32-bit integer constant expressions must be valid numbers between -2147483648 to 2147483647. DINT is the default size for integers: such constant expressions do not need any prefix. Use 2#, 8#, or 16# prefixes to specify an integer in binary, octal or hexadecimal basis, respectively. See "Valid Constant Expressions" (→ p. 23) for an example.
INT	INT#	16-bit Integer <ul style="list-style-type: none"> 16-bit integer constant expressions are valid integer values (between -32768 and +32767). Must be prefixed with INT#. All integer expressions having no prefix are considered "DINT" (→ p. 20) integers. See "Valid Constant Expressions" (→ p. 23) for an example.
LINT	LINT#	Long (64-bit) Integer <ul style="list-style-type: none"> Long integer constant expressions are valid integer values. Must be prefixed with LINT#. All integer expressions having no prefix are considered "DINT" (→ p. 20) integers. See "Valid Constant Expressions" (→ p. 23) for an example.

Type	Prefix	Description
LREAL	LREAL#	<p>Double Precision Floating Point Value</p> <ul style="list-style-type: none"> • Real constant expressions must be valid numbers, must include a dot (.). • If you need to enter a real expression having an integer value, add .0 (dot zero) at the end of the number. • You can use F or E separators for specifying the exponent in case of a scientific representation. • LREAL constants are limited to 14-15 digits of accuracy. <ul style="list-style-type: none"> • Any digits after these significant digits are lost, leading to a loss of precision. • See "Valid Constant Expressions" (→ p. 23) for an example.
REAL		<p>Single Precision Floating Point Value</p> <ul style="list-style-type: none"> • REAL is the default precision for floating points: such expressions do not require a prefix. • Important: REAL is restrictive, but because it is the default, it is recommended to explicitly declare your real constants with the LREAL# prefix. • Real constant expressions must be valid numbers, must include a dot (.). • If you need to enter a real expression having an integer value, add .0 (dot zero) at the end of the number. • You can use F or E separators for specifying the exponent in case of a scientific representation. • REAL constants are limited to 6-7 digits of accuracy. <ul style="list-style-type: none"> • Any digits after these significant digits are lost, leading to a loss of precision. • See "Valid Constant Expressions" (→ p. 23) for an example.
SINT	SINT#	<p>Small (8-bit) Integer</p> <ul style="list-style-type: none"> • Small integer constant expressions are valid integer values (between -128 and +127). • Must be prefixed with SINT#. • All integer expressions having no prefix are considered "DINT" (→ p. 20) integers. • See "Valid Constant Expressions" (→ p. 23) for an example.

Type	Prefix	Description																
STRING		<p>Character String</p> <ul style="list-style-type: none"> String expressions must be written between single quote marks (' '). The length of the string cannot exceed 255 characters. See "Valid Constant Expressions" (→ p. 23) for an example. Use these sequences to represent a special or not-printable character within a string: 																
		<table border="1"> <thead> <tr> <th>Sequence</th> <th>Description</th> </tr> </thead> <tbody> <tr> <td>\$\$</td> <td>A "\$" character</td> </tr> <tr> <td>\$'</td> <td>A single quote</td> </tr> <tr> <td>\$T</td> <td>A tab stop (ASCII code 9)</td> </tr> <tr> <td>\$R</td> <td>A carriage return character (ASCII code 13)</td> </tr> <tr> <td>\$L</td> <td>A line feed character (ASCII code 10)</td> </tr> <tr> <td>\$N</td> <td>Carriage return plus line feed characters (ASCII codes 13 and 10)</td> </tr> <tr> <td>\$P</td> <td>A page break character (ASCII code 12)</td> </tr> <tr> <td>\$xx</td> <td>Any character (xx is the ASCII code expressed on two hexadecimal digits)</td> </tr> </tbody> </table>	Sequence	Description	\$\$	A "\$" character	\$'	A single quote	\$T	A tab stop (ASCII code 9)	\$R	A carriage return character (ASCII code 13)	\$L	A line feed character (ASCII code 10)	\$N	Carriage return plus line feed characters (ASCII codes 13 and 10)	\$P	A page break character (ASCII code 12)
Sequence	Description																	
\$\$	A "\$" character																	
\$'	A single quote																	
\$T	A tab stop (ASCII code 9)																	
\$R	A carriage return character (ASCII code 13)																	
\$L	A line feed character (ASCII code 10)																	
\$N	Carriage return plus line feed characters (ASCII codes 13 and 10)																	
\$P	A page break character (ASCII code 12)																	
\$xx	Any character (xx is the ASCII code expressed on two hexadecimal digits)																	
TIME	T# or TIME#	<p>Time of Day</p> <ul style="list-style-type: none"> Time-constant expressions represent durations that must be less than 24 hours. Expressions must be prefixed by either T# or TIME#. They are expressed as a number of: <ul style="list-style-type: none"> hours followed by h minutes followed by m seconds followed by s milliseconds followed by ms The order of units (hour, minutes, seconds, milliseconds) must be respected. <ul style="list-style-type: none"> Blank characters are not allowed in the time expression. There must be at least one valid unit letter in the expression. See "Valid Constant Expressions" (→ p. 23) for an example. 																
UDINT/DWORD	UDINT#	<p>Unsigned 32-bit Integer</p> <ul style="list-style-type: none"> Unsigned 32-bit integer constant expressions are valid integer values (between 0 and 4294967295). Must be prefixed with UDINT#. All integer expressions having no prefix are considered "DINT" (→ p. 20) integers. 																
UINT/WORD	UINT#	<p>Unsigned 16-bit Integer</p> <ul style="list-style-type: none"> Unsigned 16-bit integer constant expressions are valid integer values (between 0 and +65535). Must be prefixed with UINT#. All integer expressions having no prefix are considered "DINT" (→ p. 20) integers. 																

Type	Prefix	Description
ULINT/LWORD	ULINT#	Unsigned Long Unsigned (64-bit) Integer <ul style="list-style-type: none"> • Unsigned 64-bit integer constant expressions are valid integer values. • All integer expressions having no prefix are considered "DINT" (→ p. 20) integers.
USINT/BYTE	USINT#	Unsigned 8-bit Integer <ul style="list-style-type: none"> • Unsigned small integer constant expressions are valid integer values (between 0 and 255). • Must be prefixed with USINT#. • All integer expressions having no prefix are considered "DINT" (→ p. 20) integers.

1.5.1 Examples

1.5.1.1 Valid Constant Expressions

These are examples of valid constant expressions.

Constant Expression	Type	Description
'hello'	Character String	Character string.
'I\$m here'	Character String	Character string with a quote inside (I'm here).
'name\$Tage'	Character String	Character string with two words separated by a tab.
'x\$00y'	Character String	Character string with two characters separated by a null character (ASCII code 0).
0.0	REAL	0 expressed as a REAL number.
1.002E3	REAL	1002 expressed as a REAL number in scientist format.
2#1000100	DINT	DINT integer in binary basis.
8#34712	DINT	DINT integer in octal basis.
16#abcd	DINT	DINT integer in hexadecimal basis.
123456	DINT	DINT (32-bit) integer.
FALSE	BOOL	FALSE Boolean expression.
INT#2000	16-bit Integer	16-bit integer.
LINT#1	Long (64-bit) Integer	Long (64 bit) integer having the value 1.
LREAL#1E-200	Double Precision Floating Point Value	Double precision real number.
SINT#127	Small (8-bit) Integer	Small integer.
T#1h123ms	Time of Day	TIME value with some units missing.
T#23h59m59s999ms	Time of Day	Maximum TIME value.
TIME#0s	Time of Day	Null TIME value.
TRUE	BOOL	TRUE Boolean expression.

1.5.1.2 Invalid Constant Expressions

These are examples of errors in constant expressions:

Invalid Constant Expressions	Description
'I'm here'	Quote within a string with "\$" mark omitted.
1a2b	Basis prefix ("16#") omitted.
1E-200	"LREAL#" prefix omitted for a double precision float.
BooVar := 1;	0 and 1 cannot be used for Booleans.
hello	Quotes omitted around a character string.
T#12	Time unit missing.

NOTE

There are pre-defined constants.
See Use the Defines List, Internal Defines, and Global Defines for more information.

1.6 Variables

All variables used in programs must be declared first in the variable editor.

Each variable belongs to a group and must be identified by a unique name in its group.

1.6.1 Groups

A group is a set of variables.

A group refers to a physical class of variables or identifies the variables local to a program or user-defined function block.

This table lists the possible groups:

Groups	Description
%I...	Channels of an input board. <ul style="list-style-type: none"> Variables with same data type are linked to a physical input device. See "Variables" (→ p. 24).
%Q...	Channels of an output board. <ul style="list-style-type: none"> Variables with same data type are linked to a physical output device. See "Variables" (→ p. 24).
GLOBAL	Internal variables known by all programs.
PROGRAMxxx	All internal variables local to a program. The name of the group is the name of the program.
Retain Variables	Non volatile internal variables known by all programs. <ul style="list-style-type: none"> The latest values from RETAIN variables are stored from the Runtime into a file on the hard disk drive (HDD). In case of a warm (re)start, or a cold start, the Runtime initializes the variables with these stored values. The Runtime stores these values periodically per default, triggered every 10ms in an own, lower priority thread. The storage can be configured using either: <ul style="list-style-type: none"> The menu tab entry Project/Settings.../Runtime/Cycle time. The function F_SAVERETAIN used in the program code. If a device with zenon does not have a robust HDD, it is recommended to deactivate the periodical storage and store seldom. <ul style="list-style-type: none"> This can be done via a manual function call.

Groups	Description
UDFBxxx	<ul style="list-style-type: none"> All internal variables local to a User-Defined Function Block plus its IN and OUT parameters. The name of the group is the name of the program.

1.6.2 Data Type and Dimension

Each variable must have a valid data type.

- It can be either a basic data type or a function block.
 - In a function block, the variable is an instance of the function block.
- Physical I/Os must have a basic data type.
- Instances of function blocks can refer either to a standard block or to a User Defined Function Block.

If the selected data type is STRING, you must specify a maximum length. This cannot exceed 255 characters.

- See the list of Data Types.
- See Call a Function Block about using a function instance.
- Specify dimensions for an internal variable to declare Arrays.

1.6.3 Name a Variable

A variable must be identified by a unique name within its parent group.

- The variable name cannot:
 - be a reserved keyword of the programming languages.
 - have the same name as a standard or C function or function block.
- A variable must not have the same name as a program or a user-defined function block.
- The name of a variable must begin by a letter or an underscore (`_`), followed by letters, digits, or underscore marks.
 - Two consecutive underscores in a variable name is not allowed.
- Naming is case-insensitive.
 - Two names with different cases are considered as the same.

1.6.4 Variable Attributes

Physical I/Os are marked as either **Input** or **Output**.

- Each internal variable can be configured as Read / Write or Read-only.
 - See Attributes.
 - Read-only variables can be mapped to Outputs but not to Inputs.
 - Inputs can change state and a Read-only variable cannot change its value to match the input state.
- Parameters of User-Defined Function Blocks are marked as either **IN** or **OUT**.

1.7 Free Form Ladder Diagram (FFLD)

A Ladder Diagram is a list of rungs.

- Each rung represents a Boolean data flow from a power rail on the left.
 - The power rail represents the TRUE state.
 - The data flow must be understood from the left to the right.
 - Each symbol connected to the rung either changes the rung state or performs an operation.
- These are possible graphic items to be entered in FFLD diagrams:
 - Power Rails
 - FFLD Contacts and Coils

- Operations, Functions and Function blocks, represented by rectangular blocks.
 - See:
 - Function Call or Call a Function Block.
 - LABELS and Jumps JMP JMPNC JMPNCN
 - Use ST Expressions in Graphic Language

1.7.1 Use of EN Input and ENO Output for Blocks

The rung state in a FFLD diagram is always Boolean.

- Blocks are connected to the rung with their first input and output.
 - This implies that special EN and ENO input and output are added to the block if its first input or output is not Boolean.
- The EN input is a condition.
 - It means that the operation represented by the block is not performed if the rung state (EN) is FALSE.
- The ENO output always represents the same status as the EN input.
 - The rung state is not modified by a block having an ENO output.

1.7.1.1 Examples

- This is an example of "XOR / XORN" (→ p. 123) with Boolean inputs and outputs and requiring no EN or ENO pin.
 - First input is the rung.
 - The rung is the output.

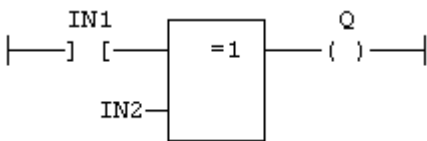

- This is an example of the "GT >" (→ p. 163) (greater than) with non-Boolean inputs and a Boolean output.
 - This block has an EN input in FFLD.
 - The comparison is executed only if EN is TRUE.

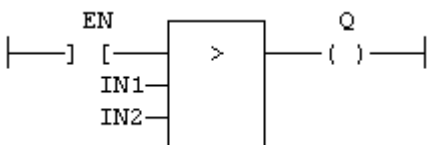

- This is an example of the "sel" (→ p. 240) with a first Boolean input but an integer output.
 - This block has an ENO output in FFLD.
 - The input rung is the selector.
 - ENO has the same value as SELECT.

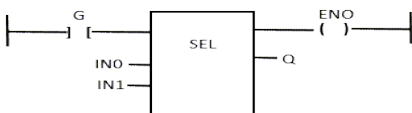

- This is an example of "Addition +" (→ p. 82) having only numerical arguments.
 - This block has both EN and ENO pins in FFLD.
 - The addition is executed only if EN is TRUE.
 - ENO has the same value as EN.

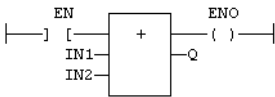

1.7.2 FFLD Contacts and Coils

This is a list of the FFLD contact and coil types:

Contacts	Coils
Negative Transition - N -	Reset (Unlatch) -(R)-
Normally Closed - / -	De-energize -(/)-
Normally closed negative transition - /N -	Negative transition sensing coil -(N)-
Normally closed positive transition - /P -	Positive transition sensing coil -(P)-
Normally Open - -	Energize -()-
Positive Transition - P -	Set (Latch) -(S)-

See Also

- "FFLD Coils" (→ p. 29)
- "FFLD Contacts" (→ p. 27)

1.7.2.1 FFLD Contacts

Contacts are basic graphic elements of the FFLD language.

- A contact is associated with a Boolean variable which is displayed above the graphic symbol.
- A contact sets the state of the rung on its right side, according to the value of the associated variable and the rung state on its left side.
- "Serialized and Parallel Contacts" (→ p. 28)
- "Transition Contacts" (→ p. 28)

The possible contact symbols are:

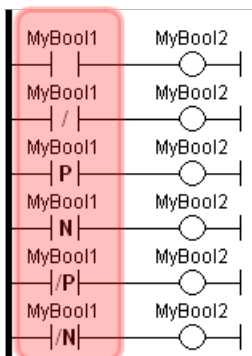

Variable	Contacts	Description
Normal	boolVariable -] [-	The flow on the right is the Boolean AND operation between: <ul style="list-style-type: none"> • (1) the flow on the left. • (2) the associated variable.

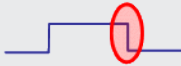
Variable	Contacts	Description
Negated	<code>boolVariable</code> -]/[-	The flow on the right is the Boolean AND operation between: <ul style="list-style-type: none"> (1) the flow on the left. (2) the negation of the associated variable.
Positive	<code>boolVariable</code> -]P[-	The flow on the right is TRUE when both: <ul style="list-style-type: none"> The flow on the left is TRUE. The associated variable is TRUE and was FALSE the last time this contact was scanned (rising edge). 
Negative Transition	<code>boolVariable</code> -]N[-	The flow on the right is TRUE when both: <ul style="list-style-type: none"> The flow on the left is TRUE. The associated variable is FALSE and was TRUE last time this contact was scanned (falling edge). 
Normally Closed Positive Transition	<code>boolVariable</code> -]/P[-	The flow on the right is TRUE when both: <ul style="list-style-type: none"> The flow on the left is TRUE. The associated variable does not change from FALSE to TRUE from the last scan of this contact to this scan (NOT rising edge).
Normally Closed Negative Transition	<code>boolVariable</code> -]/N[-	The flow on the right is TRUE when both: <ul style="list-style-type: none"> The flow on the left is TRUE. The associated variable does not change from TRUE to FALSE from the last scan of this contact to this scan (NOT falling edge).

1.7.2.1.1 Serialized and Parallel Contacts

Two serial normal contacts represent an AND ANDN & operation.

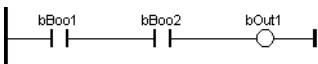

Two contacts in parallel represent an OR / ORN operation.

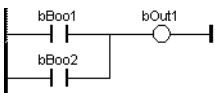

1.7.2.1.2 Transition Contacts

The transition contacts -]P[-, -]N[-/P[-, and -]N[- compare the current state of the Boolean variable to the Boolean's state the last time the contact was scanned.

- This means the Boolean variable could change states several times during a scan, but if it's back to the same state when the transition contact is scanned, the transition contact will not produce a TRUE.
- Some function blocks can complete immediately.
 - Therefore a different approach, other than using transition contacts, is needed to determine if a function block completed successfully.

Example

MC_GrpEnable executes and turns on its Done output immediately.

In this code:

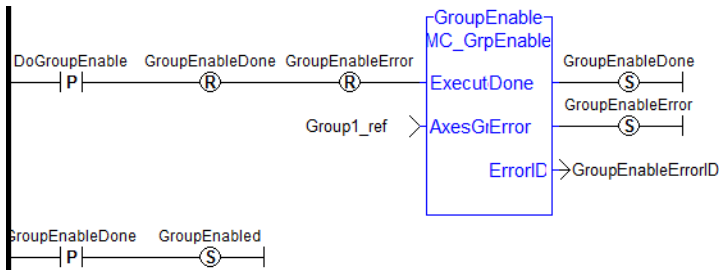

- The **GroupEnableDone** positive transition contact only provides a TRUE the first time **MC_GrpEnable** is executed.
- For all subsequent executions, the positive transition contact does not provide a TRUE since **GroupEnableDone** is TRUE every time the contact is scanned.

To remedy this, this code uses the SET and RESET of a Boolean (i.e., EnableRequest) to provide a way to detect each successful execution of the function block:

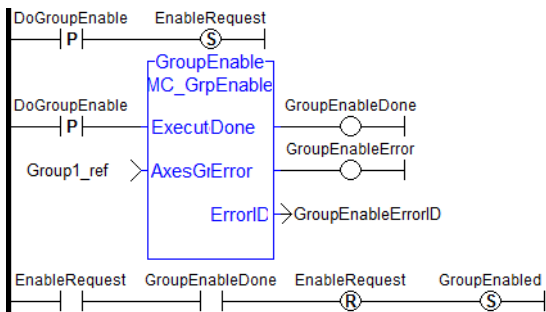

TIP

When a contact or coil is selected, press the **Spacebar** to change its type (e.g., normal, negated, etc.)
 When the application is running, select a contact and press the **Spacebar** to swap its value between TRUE and FALSE.

1.7.2.2 FFLD Coils

Coils are basic graphic elements of the FFLD language.

- A coil is associated with a Boolean variable displayed above the graphic symbol.
- A coil performs a change of the associated variable according to the flow on its left-hand side.
- The possible coil symbols are:

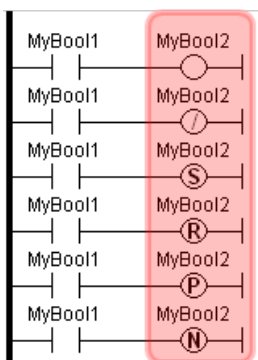

Variable	Coils	Description
Negated	boolVariable - (/) -	The associated variable is forced to the negation of the flow on the left of the coil.
Negative Transition	boolVariable - (N) -	The associated variable is forced to TRUE if the flow on the left changes from TRUE to FALSE (and forced to FALSE in all other cases).
Normal	boolVariable - () -	The associated variable is forced to the value of the flow on the left of the coil.
Positive Transition	boolVariable - (P) -	The associated variable is forced to TRUE if the flow on the left changes from FALSE to TRUE (and forced to FALSE in all other cases).
Reset	boolVariable - (R) -	<p>The associated variable is forced to FALSE if the flow on the left is TRUE.</p> <p>No action if the rung state is FALSE.</p> <p>Rules for Reset coil animation:</p> <ul style="list-style-type: none"> • If the Power Flow on left is TRUE: <ul style="list-style-type: none"> • The horizontal lines are red. • The variable above (R) is black. • The R and the circle around the R are black. • If the Power Flow on left is FALSE and variable above reset coil is NOT Energized (OFF). <ul style="list-style-type: none"> • The horizontal lines are black. • The variable above (R) is black. • The R and the circle around the R are black. • If the Power Flow on left is FALSE and variable above reset coil is Energized (ON). <ul style="list-style-type: none"> • The horizontal lines are black. • The variable above (R) is red. • The R and the circle around the R are red.
Set	boolVariable - (S) -	<p>The associated variable is forced to TRUE if the flow on the left is TRUE.</p> <p>No action if the flow is FALSE.</p> <p>Rules for Set coil animation:</p> <ul style="list-style-type: none"> • If the Power Flow on left is TRUE: <ul style="list-style-type: none"> • The horizontal wires on either side of the (S) are red. • The variable and the (S) are red. • If the Power Flow on left is FALSE and the (S) variable is Energized (ON). <ul style="list-style-type: none"> • The horizontal lines on either side of (S) are black. • The variable and the (S) are red. • In all other cases: <ul style="list-style-type: none"> • The horizontal wires are black. • The variable and the (S) are black.

TIP

When a contact or coil is selected, press the **Spacebar** to change its type (e.g., normal, negated, etc.)

When the application is running, select a contact and press the **Spacebar** to swap its value between TRUE and FALSE.

IMPORTANT

Although coils are commonly put at the end, the rung can be continued after a coil.

The flow is **never changed** by a coil symbol.

2 PLC Advanced Libraries

These functions and function blocks perform advanced operations.

- "All Functions - Alphabetical" (→ p. 31)
 - "Analog Signal Processing" (→ p. 32)
 - "Alarm Management" (→ p. 32)
 - "Communication" (→ p. 32)
- "Data Collections and Serialization" (→ p. 32)
 - "Data Log" (→ p. 32)
 - "Special Operations" (→ p. 33)

2.1 All Functions - Alphabetical

Name	Description
Alarm_A	Alarm with automatic reset.
Alarm_M	Alarm with manual reset.
ApplyRecipeColumn	Apply the values of a column from a recipe file.
average / averageL	Calculates the average of signal samples.
CurveLin	Linear interpolation on a curve.
derivate	Computes the derivative of a signal with respect to time.
FIFO	Manages a first in / first out list.
FilterOrder1	First order filter.
hyster	Hysteresis detection.
integral	Calculates the integral of a signal with respect to time.
LIFO	Manages a last in / first out list.
lim_alm	Detects high and low limits of a signal with hysteresis.
LogFileCSV	Create a log file in CSV format for a list of variables.
PID	PID loop.
PWM	Generate a PWM signal.
RAMP	Limit the ascendance or descendance of a signal.
rand	Returns a pseudo-random integer value between 0 (zero) and (base - 1).
SD Card Mounting Functions	Mounting an SD card.
SerializeIn	Extract the value of a variable from a binary frame.
SerializeOut	Copy the value of a variable to a binary frame.
SigID	Get the identifier of a Signal resource.
SigPlay	Generate a signal defined in a resource.
SigScale	Get a point from a Signal resource.
stackint	Manages a stack of DINT integers.

Name	Description
SurfLin	Linear interpolation on a surface.
VLID	Gets the identifier (ID) of an embedded list of variables.

2.1.1 Alarm Management

Name	Description
Alarm_A	Alarm with automatic reset.
Alarm_M	Alarm with manual reset.
lim_alm	Detects high and low limits of a signal with hysteresis.

2.1.2 Analog Signal Processing

Name	Description
average / averageL	Calculates the average of signal samples.
CurveLin	Linear interpolation on a curve.
derivate	Computes the derivative of a signal with respect to time.
hyster	Hysteresis detection.
integral	Calculates the integral of a signal with respect to time.
lim_alm	Detects high and low limits of a signal with hysteresis.
PID	PID loop.
RAMP	Limit the ascendance or descendance of a signal.
rand	Returns a pseudo-random integer value between 0 (zero) and (base - 1).
SigPlay	Generate a signal defined in a resource.
SigScale	Get a point from a Signal resource.
SurfLin	Linear interpolation on a surface.

2.1.3 Communication

- AS-interface Functions

2.1.4 Data Collections and Serialization

Name	Description
FIFO	Manages a first in / first out list.
LIFO	Manages a last in / first out list.
SerializeIn	Extract the value of a variable from a binary frame.
SerializeOut	Copy the value of a variable to a binary frame.
stackint	Manages a stack of DINT integers.

2.1.5 Data Log

Name	Description
LogFileCSV	Create a log file in CSV format for a list of variables.

2.1.6 Special Operations

Name	Description
ApplyRecipeColumn	Apply the values of a column from a recipe file.
CycleStop	Sets the application in cycle stepping mode.
EnableEvents	Enable or disable the production of events for binding (runtime to runtime variable exchange).
FatalStop	Breaks the cycle and stop with fatal error.
FilterOrder1	First order filter.
GetSysInfo	Get system information.
printf	Display a trace output.
SigID	Get the identifier of a Signal resource.
VLID	Gets the identifier (ID) of an embedded list of variables.

2.2 AS-interface Functions

These functions enable special operation on AS-i networks:

Function	Description
ASiReadPI	Read actual parameters of an AS-i slave.
ASiReadPP	Read permanent parameters of an AS-i slave.
ASiSendParam	Send parameters to an AS-i slave.
ASiStorePI	Store actual parameters as permanent parameters.
ASiWritePP	Write permanent parameters of an AS-i slave.

ⓘ IMPORTANT

AS-i networking may be not available on some targets.
See the OEM instructions for more information.

2.2.1 Interface

```
Params := ASiReadPP (Master, Slave);
bOK := ASiWritePP (Master, Slave, Params);
bOK := ASiSendParam (Master, Slave, Params);
Params := ASiReadPI (Master, Slave);
bOK := ASiStorePI (Master);
```

2.2.2 Arguments

```
Master : DINT Index of the AS-i master (1..N) such as shown in configuration.
Slave : DINT Address of the AS-i slave (1..32 / 33..63).
```

```
Params : DINT Value of AS-i parameters.
bOK : BOOL TRUE if successful.
```

2.3 File Management

File Management functions provide the ability to:

- Read machine recipes or other machine operational data into the KAS program from the SD card, USB flash drive, or a shared directory.
- Read cam tables into the program from the SD card, USB flash drive, or a shared directory.
- Store machine operational data on internal PxMM or PCMM2G flash memory (retrievable through the Web server), the SD card, USB flash drive, or a shared directory.

NOTE

A shared directory connection is setup through the Web server.

TIP

- Functions to parse out information from a file using a string format can be found in "String Operations" (→ p. 250).
- If the file is in a .CSV format, these functions can be used: "LogFileCSV" (→ p. 74), "ApplyRecipeColumn" (→ p. 43).
- You can create, store, and retrieve recipes and other data using either:
 - the AKI Terminals. For more information see the KVB manual.
 - an external bus connection to the PxMM or PCMM2G with a supported fieldbus (e.g., UDP or HTTP).

2.3.1 Sequential Read / Write Function Blocks

These function blocks enable sequential read / write operations in disk files:

Name	Description
FileClose	Closes an open file.
FileCopy	Copies a file's contents to a new file.
FileDelete	Removes a file from the file system.
FileEOF	Test if the end of the file is reached in a file that is open for reading.
FileExists	Tests if a file exists.
FileOpenA	Create or open a file in append mode.
FileOpenR	Open a file for reading.
FileOpenW	Create or reset a file and open it for writing.
FileReadBinData	Read binary data from a file.
FileReadLine	Reads a string value from a text file.
FileRename	Renames a file.
FileSeek	Sets the current position in an open file.
FileSize	Gets the size of a file.
FileWriteBinData	Write binary data to a file.
FileWriteLine	Writes a string value to a text file.

2.3.2 SD card Functions

These functions handle mounting of SD cards:

Name	Use
SD_ISREADY	Verify the SD card is mounted.
SD_MOUNT	Mount the SD card.
SD_UNMOUNT	Unmount the SD card.

Each file is identified in the application by a unique handle manipulated as a DINT value.

- The file handles are allocated by the target system.
- Handles are returned by the Open function blocks and used by all other function blocks for identifying the file.

2.3.2.1 Related Function Blocks

[LogFileCSV](#) log values of variables to a CSV file

ⓘ IMPORTANT

- Files are opened and closed directly by the Operating System of the target.
 - Opening some files can be dangerous for system safety and integrity.
 - **The number of open files (from FileOpenA, FileOpenR, and FileOpenW) is limited by the resources available on the target system.**
- Verify each file successfully opened using **FileOpenA, FileOpenR, and FileOpenW**.
 - The **FileOpenW** has a corresponding FileClose to close the file.
 - Closing the file releases the file ID, making it available for operations on other files.

NOTE

- Opening a file with **FileOpenA, FileOpenR, and FileOpenW** can be unsuccessful (invalid path or file name, too many open files.)
 - Your application must check the file ID for a NULL value.
 - If the file ID is NULL (zero), then file read or write operations will fail.
- File management may be unavailable on some targets.
- Memory on the SD card is available in addition to the existing flash memory.
- Valid paths for storing files depend on the target implementation.
- Error messages are logged in the Controller log section of KAS Runtime where there is a failure in any related function block.
- Using the KAS Simulator, all path names are ignored, and files are stored in a reserved directory. Only the file name passed to the Open functions is taken into account.
- AKD PDMM / PCMM files are [big endian](#).
 - PCMM2G files are [little endian](#).

👉 TIP

Review the "File Path Conventions" (→ p. 36) to understand hardware-based functional differences.

2.3.3 SD Card Access

Files may be written to and read from an SD card. This is typically used for storing a firmware image for Recovery Mode.

Use an SD card on the controller:

1. Verify the SD card is inserted.
2. Mount the card using "SD_MOUNT" (→ p. 77).

3. Verify the card is accessible using "SD_ISREADY" (→ p. 76) before performing a read or write action.
4. Unmount the card, using "SD_UNMOUNT" (→ p. 77) after performing read / write actions.

NOTE

SD Card is not supported by PCMM2G.

TIP

Recommended: Stop all motion before using SD_MOUNT and SD_UNMOUNT.

2.3.4 File Path Conventions

Depending on the system used, paths to file locations may be defined as either:

- **Absolute** (C://dir1/file1)
- **Relative** (/dir1/file1)

Not all systems handle all options.

The paths vary depending upon the system.

System	Absolute Paths	Relative Paths	Handling of Directories
AKD PDMM PCMM PCMM2G	✗	✓	<p>There is no support for creating directories on the controller. Any path provided to the function blocks (e.g., file1) is appended to the default user data folder.</p> <p>User Data Folders</p> <ul style="list-style-type: none"> • PCMM & AKD PDMM: /mount/flash/userdata/ • PCMM2G: /home/kas/kas/userdata/
Simulator	✓	✓	<p>When a relative path is provided to the function blocks, the path is appended to the default user data folder:</p> <div style="border: 1px solid gray; padding: 5px; margin-top: 10px;"> <pre><User Directory>/Kollmorgen/Kollmorgen Automation Suite/SinopeSimulator/Application/userdata/</pre> </div>

See Also

- "File Name Warning and Limitations" (→ p. 36)
- "SD Card Path Conventions" (→ p. 37)
- "Shared Directory Path Conventions" (→ p. 37)
- "USB Flash Drive Path Conventions" (→ p. 38)

2.3.4.1 File Name Warning and Limitations

- File names in the controller's flash storage **are** case-sensitive.
- The SD card or USB flash drive (FAT16 or FAT32) **are not** case-sensitive.

Product	Storage	File System	Case-Sensitive
AKD PDMM PCMM PCMM2G	Embedded Flash	FFS3 (POSIX-like)	Yes

Product	Storage	File System	Case-Sensitive
AKD PDMM	SD card / USB flash drive	FAT16	No
PCMM		FAT32	

Example

- Two files (`MyFile.txt` and `myfile.txt`) can exist in the same directory of the controller's flash.
 - They **cannot** exist in the same directory on the controller's SD card.
- If you copy two files (via backup operation or function) with the same name but different upper/lower case letters, from the controller's flash to the SD card or USB flash drive, one of the files is lost.

ⓘ IMPORTANT

Use unique file names to prevent conflicts and to keep the application compatible across all platforms. **Do not** rely on case-sensitive file names.

See Also

- "SD Card Path Conventions" (→ p. 37)
- "Shared Directory Path Conventions" (→ p. 37)
- "USB Flash Drive Path Conventions" (→ p. 38)

2.3.4.2 Shared Directory Path Conventions

The controllers support access to a shared directory on a remote computer.

To access files in a shared directory from the controller, use `/mount/shared` at the beginning of the path, before the shared directory's relative path and file name:

```
/mount/shared/directory/filename
```

Valid Paths	Notes
<code>/mount/shared</code>	• The path is not case sensitive.
<code>mount/shared</code>	• The <code>/MOUNT/SHARED</code> , <code>MOUNT/SHARED/</code> , etc. are also valid.
<code>\mount\shared</code>	
<code>mount\shared</code>	

Example 1

Opening the file `example.txt` from a shared directory on a remote computer.

```
fileID := Inst_FileOpenA(TRUE, '/mount/shared/example.txt');
```

Example 2

Opening the file `myfiles/example.txt` from a shared directory on a remote computer.

```
fileID := Inst_FileOpenA(TRUE, '/mount/shared/myfiles/example.txt');
```

See Also

- "File Name Warning and Limitations" (→ p. 36)
- "SD Card Path Conventions" (→ p. 37)
- "USB Flash Drive Path Conventions" (→ p. 38)

2.3.4.3 SD Card Path Conventions

Access to the SD card memory requires that a valid SD card label be used at the beginning of the path followed by the relative path to the SD card.

```
(Valid SD Card Label)/(Relative Path)
```

- A valid SD card relative path starts with //, /, \\, or \.
- This is immediately followed by `SDCard` which is followed by \ or /.
- This path label is case insensitive.

The `SDCard` folder is created inside the `userdata` folder to maintain compatibility with the Simulator.

File access points to `userdata/SDCard` when a AKD PDMM `SDCard` path is used on the Simulator.

2.3.4.3.1 Valid Paths

Valid Paths	Notes
//SDCard/file1	
\Sdcard/dir1/file1	dir1 must have been already created.
/sdcard/dir1/file1	dir1 must have been already created.
//sdCard\file1	

2.3.4.3.2 Invalid Paths

Invalid Paths	Invalid Reason
///SDCard/file1	Started with more than two forward or two backward slashes.
^Sdcard/dir1/file1	Started with one forward and one backward slash.
/sdcarddir1/file1	No forward or backward slash.
/sdcard1/dir1/file1	Invalid label.

See Also

- "File Name Warning and Limitations" (→ p. 36)
- "Shared Directory Path Conventions" (→ p. 37)
- "USB Flash Drive Path Conventions" (→ p. 38)

2.3.4.4 USB Flash Drive Path Conventions

Access to the USB flash drive memory requires that a valid USB flash drive label be used at the beginning of the path, followed by the relative path to the USB flash drive.

```
(Valid USB Flash Drive Label)/(Relative Path)
```

- A valid USB flash drive relative path starts with //, /, \\, or \.
- This is immediately followed by `usbflash` which is followed by \ or /.
- This path label is case insensitive.

The `usbflash` folder is created inside the `userdata` folder to maintain compatibility with the Simulator.

File access points to `userdata/usbflash` when a PCMM2G `usbflash` path is used on the Simulator.

2.3.4.4.1.1 Valid Paths

Valid Paths	Notes
//usbflash/file1	
\usbflash/dir1/file1	dir1 must have been already created.
/usbflash/dir1/file1	dir1 must have been already created.
//usbflash\file1	

2.3.4.4.2 Invalid Paths

Invalid Paths	Invalid Reason
///usbflash/file1	Started with more than two forward or two backward slashes.
\usbflash/dir1/file1	Started with one forward and one backward slash.
/usbflashdir1/file1	No forward or backward slash.
/ubflash1/dir1/file1	Invalid label.

See Also

- "File Name Warning and Limitations" (→ p. 36)
- "SD Card Path Conventions" (→ p. 37)
- "Shared Directory Path Conventions" (→ p. 37)

2.4 PLC Advanced - Advanced



These are the PLC Advanced functions:

Name	Description
Alarm_A	Alarm with automatic reset.
Alarm_M	Alarm with manual reset.
ApplyRecipeColumn	Apply the values of a column from a recipe file.
average / averageL	Calculates the average of signal samples.
CurveLin	Linear interpolation on a curve.
derivate	Computes the derivative of a signal with respect to time.
FIFO	Manages a first in / first out list.
FilterOrder1	First order filter.
hyster	Hysteresis detection.
integral	Calculates the integral of a signal with respect to time.
LIFO	Manages a last in / first out list.
lim_alm	Detects high and low limits of a signal with hysteresis.
PWM	Generate a PWM signal.
RAMP	Limit the ascendance or descendance of a signal.
rand	Returns a pseudo-random integer value between 0 (zero) and (base - 1).
SerializeIn	Extract the value of a variable from a binary frame.

Name	Description
SerializeOut	Copy the value of a variable to a binary frame.
SigID	Get the identifier of a Signal resource.
SigPlay	Generate a signal defined in a resource.
SigScale	Get a point from a Signal resource.
stackint	Manages a stack of DINT integers.
SurfLin	Linear interpolation on a surface.
VLID	Gets the identifier (ID) of an embedded list of variables.

2.4.1 Alarm_A



Function Block - Alarm with automatic reset.

Inputs

Input	Data Type	Range	Unit	Default	Description
ACK	BOOL				Acknowledge command.
IN	BOOL				Process signal.

Outputs

Output	Data Type	Range	Unit	Description
Q	BOOL			TRUE if alarm is active.
QACK	BOOL			TRUE if alarm is acknowledged.

Remarks

- Combine this block with the lim_alm block for managing analog alarms.

2.4.1.0.1 Sequence

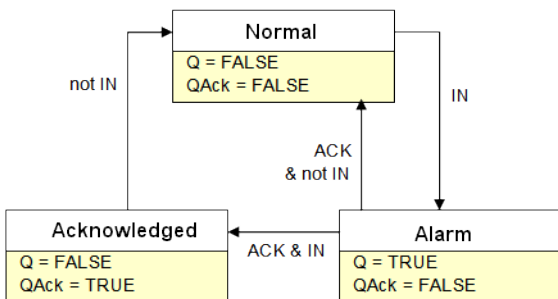

FBD Language Example

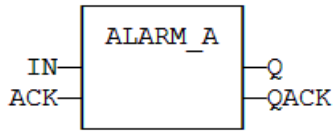

FFLD Language Example

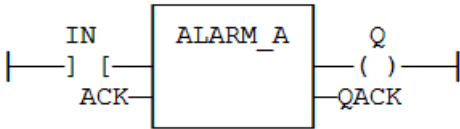

IL Language Example

```
(* MyALARM is declared as an instance of ALARM_A function block *)
Op1: CAL
MyALARM (IN, ACK)
FFLD MyALARM.Q
ST Q
FFLD MyALARM.QACK
ST
QACK
```

ST Language Example

```
(* MyALARM is declared as an instance of ALARM_A function block *)
MyALARM (IN, ACK, RST);
Q := MyALARM.Q;
QACK := MyALARM.QACK;
```

See Also

Alarm_M

2.4.2 Alarm_M

[PLCopen](#) 



Function Block - Alarm with manual reset.

Inputs

Input	Data Type	Range	Unit	Default	Description
IN	BOOL				Process signal.
ACK	BOOL				Acknowledge command.
RST	BOOL				Reset command.

Outputs

Output	Data Type	Range	Unit	Description
Q	BOOL			TRUE if alarm is active.
QACK	BOOL			TRUE if alarm is acknowledged.

Remarks

- Combine this block with the lim_alm block for managing analog alarms.

2.4.2.0.1 Sequence

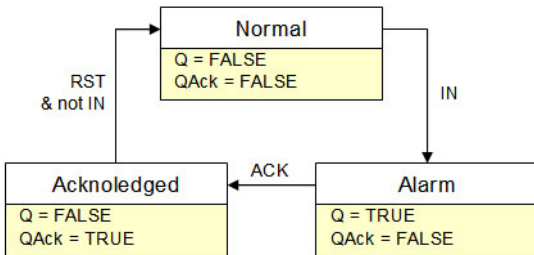

FBD Language Example

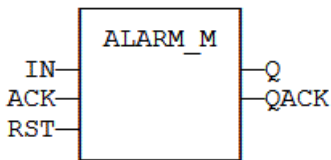

FFLD Language Example

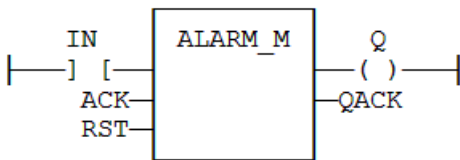

IL Language Example

```

(*MyALARM is declared as an instance of ALARM_M function block*)
Op1: CAL
MyALARM (IN, ACK, RST)
FFLD MyALARM.Q
ST Q
FFLD MyALARM.QACK
ST
QACK
    
```

ST Language Example

```

(* MyALARM is declared as an instance of ALARM_M function block *)
MyALARM (IN, ACK, RST);
    
```

```
:= MyALARM.Q;
ACK := MyALARM.QACK;
```

See Also

Alarm_A

2.4.3 ApplyRecipeColumn

[PLCopen](#) 



Function - Apply the values of a column from a recipe file.

Inputs

Input	Data Type	Range	Unit	Default	Description
FILE	STRING				Path name of the recipe file (.CSV or .RCP). Must be a constant value.
COL	DINT				Index of the column in the recipe (0 (zero) based).

Outputs

Output	Data Type	Range	Unit	Description
OK	BOOL			<ul style="list-style-type: none"> TRUE if OK. FALSE if parameters are invalid.

Remarks

- The **FILE** input is a constant string expression specifying the path name of a valid .CSV or .RCP file.
 - If no path is specified, the file is assumed to be located in the project folder.
 - CSV files are created using Excel or Notepad.
 - RCP files are created using an external recipe editor.
- In CSV files, the first line must contain column headers, and is ignored during compiling.
 - There is one variable per line.
 - The first column contains the symbol of the variable.
 - Other columns are values.
- If a cell is empty, it is assumed to be the same value as the previous (left side) cell.
 - If it is the first cell of a row, it is assumed to be null (0 or FALSE or empty string).

Example of CSV File

Example of CSV file with five variables and five set of values

```
comment lines here
TravelSpeed;100;200;300;400;500
MasterAbsPos;0;45;90;135;180
MasterDeltaPos;0;90;180;270;360
MachineSpeed;50;100;150;200;250
MachineState;0;0;1;1;2
```

NOTE

For the CSV file to be valid, ensure the data are separated with **semicolons** (NOT commas).

Usage in an FFD program where column 3 is selected.

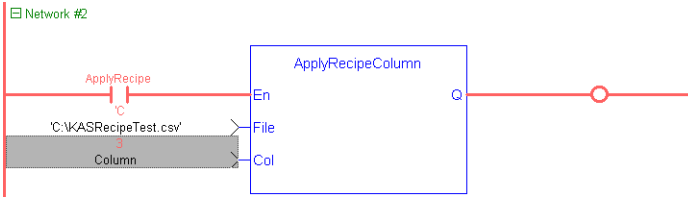

Column 3 corresponds to column E in the Excel sheet because this parameter is 0 based.

	A	B	C	D	E	F
1	comment lines here					
2	TravelSpeed	100	200	300	400	500
3	MasterAbsPos	0	45	90	135	180
4	MasterDeltaPos	0	90	180	270	360
5	MachineSpeed	50	100	150	200	250
6	MachineState	0	0	1	1	2

Result displayed in the Dictionary when the application is running.

Name	Value	Type
TravelSpeed	400.0000...	LREAL
MasterAbsPos	135.0000...	LREAL
MasterDeltaPos	270.0000...	LREAL
MachineSpeed	200.0000...	LREAL
Axis1Status	447	DINT
Axis2Status	447	DINT
MachineState	1	DINT

Example of RCP File

```

@COLNAME=Col13 Col14

@SIZECOL1=100

@SIZECOL2=100

@SIZECOL3=100

@SIZECOL4=100

bCommand

tPerio

bFast

Blink1

test_var

bOut

@EXPANDED=Blink1
    
```

ⓘ IMPORTANT

Recipe files are read at compiling time and are embedded into the downloaded application code. This implies that a modification performed in the recipe file after downloading is not taken into account by the application.

FBD Language Example

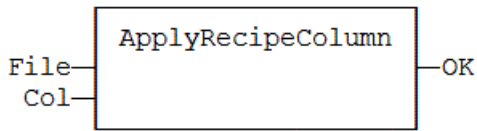

FFLD Language Example

- In the FFLD Language, the operation is executed only if the input rung (EN) is TRUE.
 - The output rung is the result of the function.
 - The function is executed only if **ApplyRecipe** is TRUE.

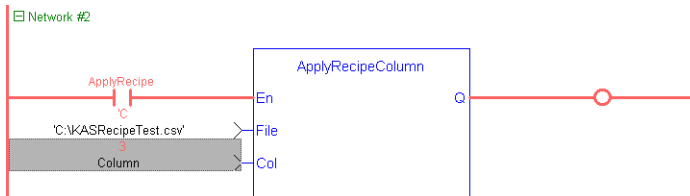

IL Language Example

```
Op1: LD
  'MyFile.rcp'
  ApplyRecipeColumn COL
ST
OK
```

ST Language Example

```
OK := ApplyRecipeColumn ('MyFile.rcp', COL);
```

2.4.4 average / averageL



 **Function Block** - Calculates the average of signal samples.

Inputs

Input	Data Type	Range	Unit	Default	Description
RUN	BOOL				Enabling command.
XIN	REAL				Input signal.
N	DINT				<ul style="list-style-type: none"> Number of samples stored for average calculation. Cannot exceed 128.

Outputs

Output	Data Type	Range	Unit	Description
XOUT	REAL			<ul style="list-style-type: none"> Average of the stored samples. averageL has LREAL arguments.

Remarks

- Average is calculated according to the number of stored samples.
 - This can be less than N when the block is enabled.
 - The N input (or the number of samples) is taken into account **only** when the RUN input is FALSE.
 - By default, the number of samples is 128.
- RUN must be reset after a change in the number of samples.
 - Cycle the RUN input when you first call this function; this clears the default.

FBD Language Example

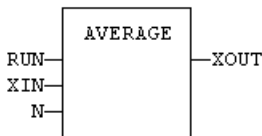

FFLD Language Example

- In the FFLD Language, the input rung is the RUN command.
 - The output rung keeps the state of the input rung.
 - ENO has the same value as RUN.

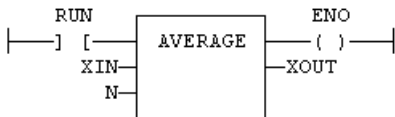

IL Language Example

```
(* MyAve is a declared instance of AVERAGE function block *)
Op1: CAL MyAve (RUN, XIN, N)
      FFLD MyAve.XOUT
      ST XOUT
```

ST Language Example

```
(* MyAve is a declared instance of AVERAGE function block. *)
MyAve (RUN, XIN, N);
XOUT := MyAve.XOUT;
```

See Also

- derivate
- hyster
- integral

- lim_alm
- stackint

2.4.5 CurveLin



 **Function Block** - Linear interpolation on a curve.

Inputs

Input	Data Type	Range	Unit	Default	Description
X	REAL				X coordinate of the point to be interpolated.
XAxis	REAL[]				X coordinates of the known points of the X axis.
YVal	REAL[]				Y coordinate of the points defined on the X axis.

Outputs

Output	Data Type	Range	Unit	Description
ERR	DINT			<ul style="list-style-type: none"> • Error code if failed. • 0 (zero) if OK.
OK	BOOL			TRUE if successful.
Y	REAL			Interpolated Y value corresponding to the X input.

Remarks

- This function performs linear interpolation in between a list of points defined in the XAxis single dimension array.
 - The output Y value is an interpolation of the Y values of the two rounding points defined in the X axis.
 - Y values of defined points are passed in the YVal single dimension array.
- Values in XAxis must be sorted from the smallest to the biggest.
 - There must be at least two points defined in the X axis.
 - YVal and XAxis input arrays must have the same dimension.
- If the X input is **less than** the smallest defined X point:
 - The Y output takes the first value defined in YVal.
 - An error is reported.
- If the X input is **greater than** the biggest defined X point:
 - The Y output takes the last value defined in YVal.
 - An error is reported.

If the function fails, the ERR output gives the cause of the error:

Error Code	Meaning
0	OK
1	Invalid dimension of input arrays
2	Invalid points for the X axis
4	X is out of the defined X axis

FBD Language Example

Not available.

FFLD Language Example

Not available.

IL Language Example

Not available.

ST Language Example

Not available.

2.4.6 derivate



 **Function Block** - Computes the derivative of a signal with respect to time.

Inputs

Input	Data Type	Range	Unit	Default	Description
RUN	BOOL	FALSE, TRUE			Run command: <ul style="list-style-type: none"> • TRUE=derivate. • FALSE=hold.
XIN	REAL				Input signal.
CYCLE	TIME				Sampling period. Must not be less than the target cycle timing.

Outputs

Output	Data Type	Range	Unit	Description
XOUT	REAL			Output signal.

Remarks

- The time unit is seconds.
- The output signal has the units of the input signal divided by seconds.
- The **derivate** block samples the input signal at a maximum rate of 1 millisecond.

FBD Language Example

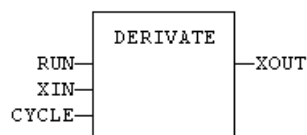

FFLD Language Example

- In the FFLD Language, the input rung is the RUN command.
 - The output rung keeps the state of the input rung.
 - ENO has the same state as RUN.

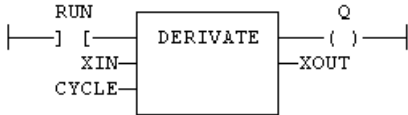

IL Language Example

```
(* MyDerv is a declared instance of DERIVATE function block *)
Op1: CAL MyDerv (RUN, XIN, CYCLE)
FFLD MyDerv.XOUT
ST XOUT
```

ST Language Example

```
(* MyDerv is a declared instance of DERIVATE function block. *)
MyDerv (RUN, XIN, CYCLE);
XOUT := MyDerv.XOUT;
```

See Also

- average / averageL
- hyster
- integral
- lim_alm
- stackint

2.4.7 FIFO



Function Block - Manages a first in / first out list.

Inputs

Inputs	Data Type	Range	Unit	Default	Description
@Tail	ANY				Value of the oldest pushed value. Updated after call.
Buf[]	ANY				Array for storing values.
IN	ANY				Value to be pushed.
POP	BOOL				Pop a new value on the rising edge.
PUSH	BOOL				Push a new value on the rising edge.
RST	BOOL				Reset the list.

Outputs

Outputs	Data Type	Range	Unit	Description
EMPTY	BOOL			TRUE if the list is empty.
OFLO	BOOL			TRUE if the overflow is on a PUSH command.
Count	DINT			Number of values in the list.
pRead	DINT			Index in the buffer of the oldest pushed value.
pWrite	DINT			Index in the buffer of the next push position.

Remarks

- **IN**, **@Tail**, and **Buf[]** must have the same data type.
 - It cannot be a STRING.
- The **@Tail** argument specifies a variable filled with the oldest push value after the block is called.
- Values are stored in the **Buf[]** array.
 - Data is arranged as a roll over buffer and is never shifted or reset.
 - Only read and write pointers and pushed values are updated.
 - The maximum size of the list is the dimension of the array.
- The first time an instance of the FIFO function block is called, that instance stores which array is passed to **Buf[]**.
 - If a later call to the same instance passes a different array for the **Buf[]** argument, the call is considered invalid and no action is performed.
 - In this instance, the **EMPTY** output returns TRUE.

FBD Language Example

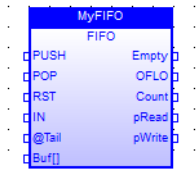

FFLD Language Example

- In the FFLD Language, the input rung is the PUSH input.
 - The output rung is the EMPTY output.



IL Language Example

```
(* MyFIFO is a declared instance of FIFO function block *)
Op1: CAL MyFIFO (PUSH, POP, RST, IN, @Tail , BUFF[])
FFLD MyFIFO.EMPTY
ST EMPTY
FFLD MyFIFO.OFLO
ST OFLO
FFLD MyFIFO.COUNT
ST COUNT
FFLD MyFIFO.PREAD
ST PREAD
FFLD MyFIFO.PWRITE
ST PWRITE
```

ST Language Example

```
(* MyFIFO is a declared instance of FIFO function block: *)
MyFIFO (PUSH, POP, RST, IN, @Tail , BUFFER);
EMPTY := MyFIFO.EMPTY;
OFLO := MyFIFO.OFLO;
COUNT := MyFIFO.COUNT;
PREAD := MyFIFO.PREAD;
PWRITE := MyFIFO.PWRITE;
```

See Also

[LIFO](#)

2.4.8 FilterOrder1



Function Block - First order filter.

Inputs

Input	Data Type	Range	Unit	Default	Description
XIN	REAL				Input analog value.
GAIN	REAL				Transformation gain.

Outputs

Output	Data Type	Range	Unit	Description
XOUT	REAL			Output signal.

Remarks

The operation performed is:

$$\text{Output} = (\text{Input} \times \text{Gain}) + (\text{OutputPrev} * (1-\text{Gain}))$$

The allowed range for the gain is [0.05 .. 1.0]

2.4.8.0.1 Example

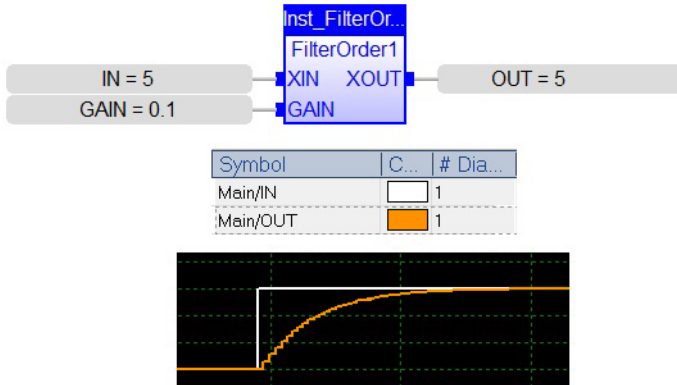

FBD Language Example

Not available.

FFLD Language Example

Not available.

IL Language Example

Not available.

ST Language Example

Filt1 is a declared instance of FilterOrder1 function block.

```
Filt1 (rIn, rGain);
Signal := Filt1.Xout;
```

2.4.9 hyster



Function Block - Hysteresis detection.

Inputs

Input	Data Type	Range	Unit	Default	Description
XIN1	REAL				First input.
XIN2	REAL				Second input.
EPS	REAL				Hysteresis.

Outputs

Output	Data Type	Range	Unit	Description
Q	BOOL			Detected hysteresis: TRUE if XIN1 becomes greater than XIN2+EPS and is not yet below XIN2-EPS.

Remarks

- The hysteresis is detected on the difference of XIN1 and XIN2 signals.

FBD Language Example

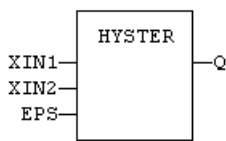

FFLD Language Example

- In the FFLD Language, the input rung (EN) is used for enabling the block.
 - The output rung is the Q output.
 - The block is not called if EN is FALSE.

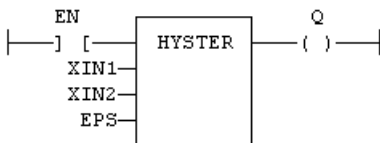

IL Language Example

```
(* MyHyst is a declared instance of HYSTER function block *)
Op1: CAL MyHyst (XIN1, XIN2, EPS)
FFLD MyHyst.Q
ST Q
```

ST Language Example

```
(* MyHyst is a declared instance of HYSTER function block. *)
MyHyst (XIN1, XIN2, EPS);
Q := MyHyst.Q;
```

See Also

- average / averageL
- derivate
- integral

- lim_alm
- stackint

2.4.10 integral



 **Function Block** - Calculates the integral of a signal with respect to time.

Inputs

Input	Data Type	Range	Unit	Default	Description
CYCLE	TIME				Sampling period. Must not be less than the target cycle timing.
R1	BOOL				Overriding reset.
RUN	BOOL				Run command: <ul style="list-style-type: none"> • TRUE = integrate. • FALSE = hold.
X0	REAL				Initial value.
XIN	REAL				Input signal.

Outputs

Output	Data Type	Range	Unit	Description
Q	DINT			Running mode report: NOT (R1).
XOUT	REAL			Output signal.

Remarks

- The time unit is seconds.
- The output signal has the units of the input signal multiplied by seconds.
- The **integral** block samples the input signal at a maximum rate of 1 millisecond.

FBD Language Example

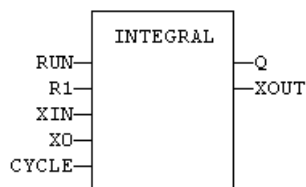

FFLD Language Example

- In the FFLD Language, the input rung is the RUN command.
 - The output rung is the Q report status.

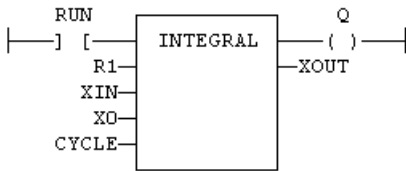

IL Language Example

```
(* MyIntg is a declared instance of INTEGRAL function block. *)
Op1: CAL MyIntg (RUN, R1, XIN, X0, CYCLE)
      FFLD MyIntg.Q
      ST Q
      FFLD MyIntg.XOUT
      ST XOUT
```

ST Language Example

```
(* MyIntg is a declared instance of INTEGRAL function block. *)
MyIntg (RUN, R1, XIN, X0, CYCLE);
Q := MyIntg.Q;
XOUT := MyIntg.XOUT;
```

See Also

- "average / averagel" (→ p. 45)
- "derivate" (→ p. 48)
- "hyster" (→ p. 52)
- "lim_alm" (→ p. 57)
- stackint

2.4.11 LIFO



Function Block - Manages a last in / first out list.

Inputs

Inputs	Data Type	Range	Unit	Default	Description
BUFFER	ANY				Array for storing values.
NEXTOUT	ANY				Value at the top of the stack. Updated after call.
NEXTIN	ANY				Value to be pushed.
POP	BOOL				Pop a new value on the rising edge.
PUSH	BOOL				Push a new value on the rising edge.
RST	BOOL				Reset the list.

Outputs

Outputs	Data Type	Range	Unit	Description
EMPTY	BOOL			TRUE if the list is empty.
OFLO	BOOL			TRUE if the overflow is on a PUSH command.
Count	DINT			Number of values in the list.
pRead	DINT			Index in the buffer of the top of the stack.
pWrite	DINT			Index in the buffer of the next push position.

Remarks

- **NEXTIN**, **NEXTOUT**, and **BUFFER** must have the same data type.
 - It cannot be a **STRING**.
- The **NEXTOUT** argument specifies a variable filled with the value at the top of the stack after the block is called.
- Values are stored in the **BUFFER** array.
 - Data is never shifted or reset.
 - Only read and write pointers and pushed values are updated.
 - The maximum size of the stack is the dimension of the array.
- The first time an instance of the LIFO function block is called, that instance stores which array is passed to **BUFFER**.
 - If a later call to the same instance passes a different array for the **BUFFER** argument, the call is considered invalid and no action is performed.
 - The **EMPTY** output returns **TRUE** in this case.

FBD Language Example

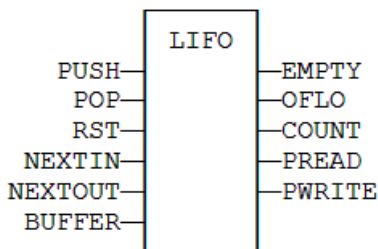

FFLD Language Example

- In the FFLD Language, the input rung is the **PUSH** input.
 - The output rung is the **EMPTY** output.

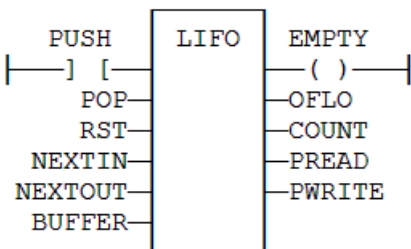

IL Language Example

```
(* MyLIFO is a declared instance of LIFO function block *)
Op1: CAL MyLIFO (PUSH, POP, RST, NEXTIN, NEXTOUT, BUFFER)
FFLD MyLIFO.EMPTY
ST EMPTY
FFLD MyLIFO.OFLO
ST OFLO
FFLD MyLIFO.COUNT
ST COUNT
FFLD MyLIFO.PREAD
ST PREAD
FFLD MyLIFO.PWRITE
ST PWRITE
```

ST Language Example

```
(* MyLIFO is a declared instance of LIFO function block. *)
MyLIFO (PUSH, POP, RST, NEXTIN, NEXTOUT, BUFFER);
EMPTY := MyLIFO.EMPTY;
OFLO := MyLIFO.OFLO;
COUNT := MyLIFO.COUNT;
PREAD := MyLIFO.PREAD;
PWRITE := MyLIFO.PWRITE;
```

See Also

FIFO

2.4.12 lim_alm



 **Function Block** - Detects high and low limits of a signal with hysteresis.

Inputs

Input	Data Type	Range	Unit	Default	Description
EPS	REAL				Value of the hysteresis.
H	REAL				Value of the high limit.
L	REAL				Value of the low limit.
X	REAL				Input signal.

Outputs

Output	Data Type	Range	Unit	Description
Q	BOOL			TRUE if the signal exceeds one of the limits. Equals to QH OR QL.
QH	BOOL			TRUE if the signal exceeds the high limit.
QL	BOOL			TRUE if the signal exceeds the low limit.

Remarks

None

FBD Language Example

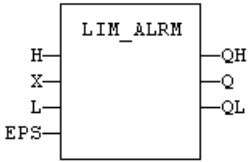

FFLD Language Example

- In the FFLD Language, the input rung (EN) is used for enabling the block.
 - The output rung is the QH output.
 - The block is not called if EN is FALSE.

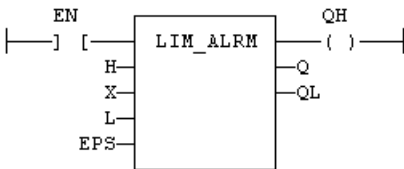

IL Language Example

```
(* MyAlarm is a declared instance of LIM_ALARM function block *)
Op1: CAL MyAlarm (H, X, L, EPS)
      FFLD MyAlarm.QH
      ST QH
      FFLD MyAlarm.Q
      ST Q
      FFLD MyAlarm.QL
      ST QL
```

ST Language Example

```
(* MyAlarm is a declared instance of LIM_ALARM function block *)
MyAlarm (H, X, L, EPS);
QH := MyAlarm.QH;
Q := MyAlarm.Q;
QL := MyAlarm.QL;
```

See Also

- Alarm_A
- Alarm_M

2.4.13 PWM



 **Function Block** - Generate a PWM signal.

Inputs

Input	Data Type	Range	Unit	Default	Description
XIN	REAL				Input analog value.
XinMin	REAL				Minimum input value.
XinMax	REAL				Maximum input value.
MinPulse	TIME				Minimum pulse time on output.
Period	TIME				Period of the output signal.

Outputs

Output	Data Type	Range	Unit	Description
Q	BOOL			Blinking PWM signal.

Remarks

- The input value is truncated to [XinMin .. XinMax] interval.
 - XinMax must be greater than XinMin.
- The signal is TRUE during:

$$(Xin - XinMin) * Period / (XinMax - XinMin)$$

FBD Language Example

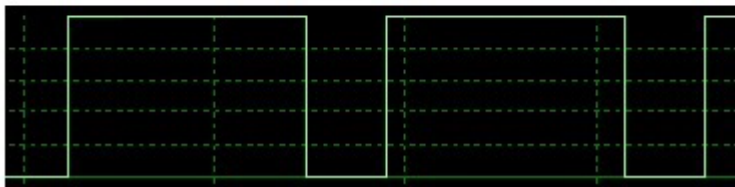
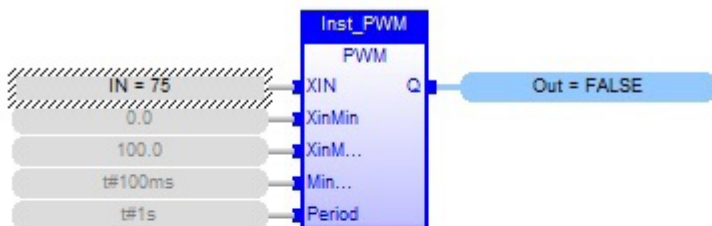

FFLD Language Example

Not available.

IL Language Example

Not available.

ST Language Example

PWM1 is a declared instance of PWM function block.

```
PWM1 (rIn, rInMin, rInMax, tMinPulse, tPeriod);
Signal := PWM1.Q;
```

2.4.14 RAMP

PLCopen 



Function - Limit the ascendance or descendance of a signal.

Inputs

Input	Data Type	Range	Unit	Default	Description
IN	REAL				Input signal.
ASC	REAL				Maximum ascendance during time base.
DSC	REAL				Maximum descendant during time base.
TM	TIME				Time base.
RST	BOOL				Reset.

Outputs

Output	Data Type	Range	Unit	Description
OUT	REAL			Ramp signal.

Remarks

- Parameters are not updated constantly.
 - They are taken into account only when the:
 - The block is called the first time.
 - Reset input (RST) is TRUE.
 - In these two situations, the output is set to the value of IN input.
- ASC and DSC give the maximum ascendant and descendant growth during the TB time base.
 - Both must be expressed as **positive** numbers.

Time Diagram

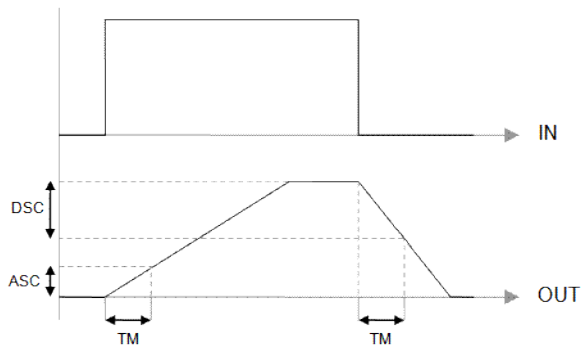

FBD Language Example

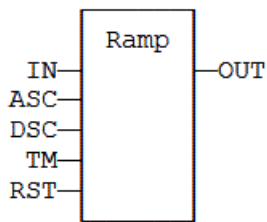

FFLD Language Example

- In the FFLD Language, the operation is executed only if the input rung (EN) is TRUE.
 - The output rung (ENO) keeps the same value as the input rung.
- The function is executed only if EN is TRUE.
- ENO keeps the same value as EN.

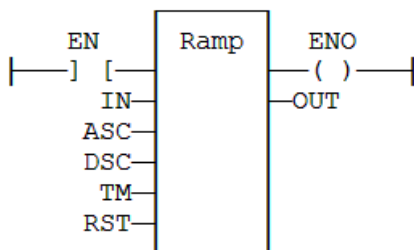

IL Language Example

```
(* MyRamp is a declared instance of RAMP function block *)
Op1: CAL
MyRamp (IN, ASC, DSC, TM, RST)
FFLD MyBlinker.OUT
ST OUT
```

ST Language Example

```
(* MyRamp is a declared instance of RAMP function block *)
MyRamp (IN, ASC, DSC, TM, RST);
OUT := MyBlinker.OUT;
```

2.4.15 rand

PLCopen 



Function Block - Returns a pseudo-random integer value between 0 (zero) and (base - 1).

Inputs

Input	Data Type	Range	Unit	Default	Description
base	DINT	1 to 2147483647	N/A	No default	The number of possible outcomes. Example: When base is 5, there are 5 possible outcomes: 0,1,2,3,4.

Outputs

Output	Data Type	Range	Unit	Description
Return Value	DINT	0 (zero) to (base - 1)	N/A	The generated pseudo-random number.

Remarks

- **rand** uses a fast high-quality number generation algorithm.
 - The algorithm is not cryptographically secure.
 - It is sufficient where security is not a concern.
- There is no way to seed the random number generator.
 - On first use, the random number generated is seeded by time.
 - While unlikely, it is possible to receive the same pattern of generated numbers after the controller reboots.

FBD Language Example

Not available.

FFLD Language Example

Not available.

IL Language Example

Not available.

ST Language Example

```
dieValue := 1 + rand(6);
```

2.4.16 Serializeln

PLCopen 

 **Function** - Extract the value of a variable from a binary frame.

Inputs

Input	Data Type	Range	Unit	Default	Description
En	BOOL	0 to 1	N/A	No default	Execute the function.
Frame[]	USINT	0,+65535	N/A	N/A	<ul style="list-style-type: none"> Source buffer. Must be an array.
Data	ANY(*)	No range	N/A	No default	Destination variable to be copied.
Pos	DINT	0,+65535	N/A	N/A	Position in the source buffer.
BigEndian	BOOL	0 to 1	N/A	No default	TRUE if the frame is encoded with Big Endian format.

(*) DATA cannot be a STRING.

Outputs

Output	Data Type	Range	Unit	Description
OK	BOOL		N/A	Returns TRUE when the function successfully executes.
NextPos	DINT		N/A	<ul style="list-style-type: none"> Position in the source buffer after the copied data. 0 (zero) in case of error (e.g., invalid position or buffer size).

Remarks

- Used to extract data from a communication frame in binary format.
- This function cannot be used to serialize STRING variables.
- The **DATA** input must be directly connected to a variable.
 - It cannot be a constant or complex expression.
 - This variable is forced with the extracted value.
- The **FRAME** input must fit the input position and data size.
 - If the value cannot be safely extracted, the function returns 0 (zero).
- The function returns the position in the source frame after the extracted data.
 - The return value can be used as a position for the next serialization.

This function extracts these number of bytes from the source frame:

Bytes	Description
1 byte	BOOL, BYTE, SINT, and USINT variables.
2 bytes	INT, UINT, and WORD variables.
4 bytes	DINT, DWORD, REAL, and UDINT variables.
8 bytes	LINT and LREAL variables.

FBD Language Example

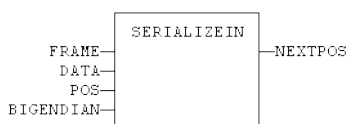

FFLD Language Example

- In the FFLD Language, the operation is executed only if the input rung (EN) is TRUE.
 - The output rung (ENO) keeps the same value as the input rung.

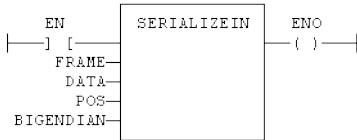

IL Language Example

Not available.

ST Language Example

```
Q := SERIALIZEIN (FRAME, DATA, POS, BIGENDIAN);
```

See Also

"SerializeOut" (→ p. 64)

2.4.17 SerializeOut



Function - Copy the value of a variable to a binary frame.

Inputs

Input	Data Type	Range	Unit	Default	Description
En	BOOL	0 to 1	N/A	No default	Execute the function.
Frame[]	USINT	0,+65535	N/A	N/A	<ul style="list-style-type: none"> Destination buffer. Must be an array.
Data	ANY(*)	No range	N/A	No default	Source variable to be copied.
Pos	DINT	0,+65535	N/A	N/A	Position in the destination buffer.
BigEndian	BOOL	0 to 1	N/A	No default	TRUE if the frame is encoded with Big Endian format.

(*) DATA cannot be a STRING.

Outputs

Output	Data Type	Range	Unit	Description
OK	BOOL		N/A	Returns TRUE when the function successfully executes.
NextPos	DINT		N/A	<ul style="list-style-type: none"> Position in the destination buffer after the copied data. 0 (zero) in case of error (e.g., invalid position or buffer size).

Remarks

- Used to build a communication frame in binary format.
- This function cannot be used to serialize STRING variables.
- The **FRAME** input must be an array large enough to receive the data.
 - If the data cannot be safely copied to the destination buffer, the function returns 0 (zero).
- The function returns the position in the destination frame after the copied data.
 - The return value can be used as a position for the next serialization.

This function copies these number of bytes to the destination frame:

Bytes	Description
1 byte	BOOL, BYTE, SINT, and USINT variables.
2 bytes	INT, UINT, and WORD variables.
4 bytes	DINT, DWORD, REAL, and UDINT variables.
8 bytes	LINT and LREAL variables.

FBD Language Example

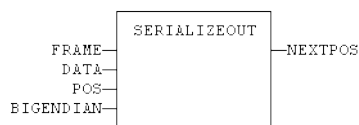

FFLD Language Example

- In the FFLD Language, the operation is executed only if the input rung (EN) is TRUE.
 - The output rung (ENO) keeps the same value as the input rung.

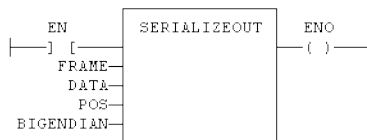

IL Language Example

Not available.

ST Language Example

```
Q := SERIALIZEOUT (FRAME, DATA, POS, BIGENDIAN);
```

See Also

"SerializeIn" (→ p. 62)

2.4.18 SigID



 **Function** - Get the identifier of a Signal resource.

Inputs

Input	Data Type	Range	Unit	Default	Description
SIGNAL	STRING				Name of the signal resource. Must be a constant value.
COL	STRING				Name of the column within the signal resource. Must be a constant value.

Outputs

Output	Data Type	Range	Unit	Description
ID	DINT			ID of the signal to be passed to other blocks.

Remarks

- Some blocks have arguments that refer to a signal resource.
 - For all these blocks, the signal argument is materialized by a numerical identifier.

FBD Language Example

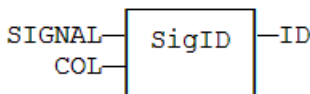

FFLD Language Example

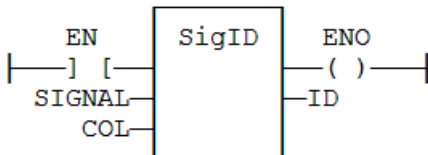

IL Language Example

```

Op1: LD    'MySignal'
      SigID 'FirstColumn'
      ST ID
    
```

ST Language Example

```

ID := SigID ('MySignal', 'FirstColumn');
    
```

See Also

- "SigPlay" (→ p. 67)
- "SigScale" (→ p. 68)

2.4.19 SigPlay

PLCopen 

 **Function Block** - Generate a signal defined in a resource.

Inputs

Input	Data Type	Range	Unit	Default	Description
IN	BOOL				Triggering command.
ID	DINT				ID of the signal resource, provided by the "SigID" (→ p. 65) function.
RST	BOOL				Reset command.
TM	TIME				Minimum duration between two changes of the output.

Outputs

Output	Data Type	Range	Unit	Description
Q	BOOL			TRUE when the signal is finished.
OUT	REAL			Generated signal.
ET	TIME			Elapsed time.

Remarks

- The ID argument is the identifier of the signal resource.
 - Use the "SigID" (→ p. 65) function to get this value.
- The IN argument is used as a Play / Pause command to play the signal.
 - The signal is not reset to the beginning when IN becomes FALSE.
 - Instead, use the RST input that resets the signal and forces the OUT output to 0 (zero).
- The TM input specifies the minimum amount of time in between two changes of the output signal.
 - This parameter is ignored if less than the cycle scan time.
- This function block includes its own timer.
 - Alternatively, use the "SigScale" (→ p. 68) function if you want to trigger the signal using a specific timer.

FBD Language Example

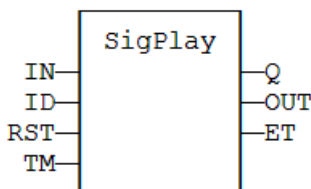

FFLD Language Example

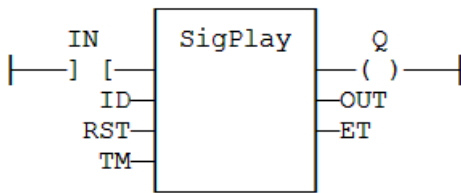

IL Language Example

```
Op1: FFLD IN
SigScale ID
ST      Q
```

ST Language Example

```
MySig (II, ID, RST, TM);
Q := MySig.Q;
OUT := MySig.OUT;
ET := MySig.ET;
```

See Also

- "SigID" (→ p. 65)
- "SigScale" (→ p. 68)

2.4.20 SigScale

PLCopen 



Function - Get a point from a Signal resource.

Inputs

Input	Data Type	Range	Unit	Default	Description
ID	DINT				ID of the signal resource, provided by the "SigID" (→ p. 65) function.
TIME	TIME				Time (X) coordinate of the point within the signal resource.

Outputs

Output	Data Type	Range	Unit	Description
Q	REAL			Value (Y) coordinate of the point in the signal.

Remarks

- The ID argument is the identifier of the signal resource.
 - Use the "SigID" (→ p. 65) function to get this value.

- This function:
 - Converts a time value to an analog value as defined in the signal resource.
 - Can be used instead of the "SigPlay" (→ p. 67) function block to trigger the signal using a specific timer.

FBD Language Example

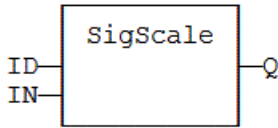

FFLD Language Example

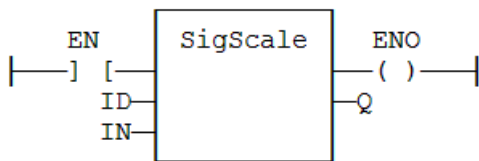

IL Language Example

```
Op1: LD      IN
      SigScale ID
      ST      Q
```

ST Language Example

```
Q := SigScale (ID, IN);
```

See Also

- "SigID" (→ p. 65)
- "SigPlay" (→ p. 67)

2.4.21 stackint

[PLCopen](#)



Function Block - Manages a stack of DINT integers.

Inputs

Input	Data Type	Range	Unit	Default	Description
PUSH	BOOL				Command: When changing from FALSE to TRUE, the value of IN is pushed on the stack.

Input	Data Type	Range	Unit	Default	Description
POP	BOOL				Pop command: When changing from FALSE to TRUE, deletes the top of the stack.
R1	BOOL				Reset command: If TRUE, the stack is emptied and its size is set to N.
IN	DINT				Value to be pushed on a rising pulse of PUSH.
N	DINT				Maximum stack size. Cannot exceed 128.

Outputs

Output	Data Type	Range	Unit	Description
EMPTY	BOOL			TRUE if the stack is empty.
OFLO	BOOL			TRUE if the stack is full.
OUT	DINT			Value at the top of the stack.

Remarks

- Push and pop operations are performed on rising pulse of PUSH and POP inputs.
- The specified size (N) is taken into account only when the R1 (reset) input is TRUE.

FBD Language Example

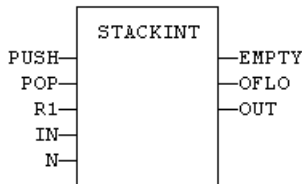

FFLD Language Example

- In the FFLD language, the input rung is the PUSH command.
 - The output rung is the EMPTY output.

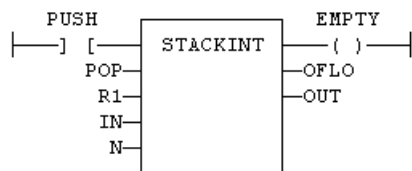

IL Language Example

```
(* MyStack is a declared instance of STACKINT function block *)
Op1: CAL MyStack (PUSH, POP, R1, IN, N)
      FFLD MyStack.EMPTY
      ST EMPTY
```

```

FFLD MyStack.OFLO
ST OFLO
FFLD MyStack.OUT
ST OUT

```

ST Language Example

```

(* MyStack is a declared instance of STACKINT function block *)
MyStack (PUSH, POP, R1, IN, N);
EMPTY := MyStack.EMPTY;
OFLO := MyStack.OFLO;
OUT := MyStack.OUT;

```

See Also

- "average / averageL" (→ p. 45)
- "derivate" (→ p. 48)
- "hyster" (→ p. 52)
- "integral" (→ p. 54)
- "lim_alm" (→ p. 57)

2.4.22 SurfLin

[PLCopen](#) 



Function Block - Linear interpolation on a surface.

Inputs

Input	Data Type	Range	Unit	Default	Description
X	REAL				X coordinate of the point to be interpolated.
XAxis	REAL[]				X coordinates of the known points of the X axis.
Y	REAL				Y coordinate of the point to be interpolated.
YAxis	REAL[]				Y coordinates of the known points of the Y axis.
ZVal	REAL[]				Z coordinate of the points defined by the axis.

Outputs

Output	Data Type	Range	Unit	Description
ERR	DINT			<ul style="list-style-type: none"> • Error code if failed. • 0 (zero) if OK.
OK	BOOL			TRUE if successful.
Z	REAL			Interpolated Z value corresponding to the X,Y input point.

Remarks

This function performs linear surface interpolation in between a list of points defined in XAxis and YAxis single dimension arrays.

- The output Z value is an interpolation of the Z values of the four rounding points defined in the axis.
 - Z values of defined points are passed in the ZVal matrix (two dimension array).
 - ZVal dimensions must be understood as: ZVal [iX , iY]
- Values in X and Y axis must be sorted from the smallest to the biggest.
 - There must be at least two points defined in each axis.
 - ZVal must fit the dimension of XAxis and YAxis arrays.
 - For instance:
 - XAxis : ARRAY [0..2] of REAL;
 - YAxis : ARRAY [0..3] of REAL;
 - ZVal : ARRAY [0..2,0..3] of REAL;
- If the input point is outside the rectangle defined by XAxis and YAxis limits, the Z output is bound to the corresponding value and an error is reported.

If the function fails, the ERR output gives the cause of the error:

Error Code	Meaning
0	OK
1	Invalid dimension of input arrays.
2	Invalid points for the X axis.
3	Invalid points for the Y axis.
4	X,Y point is out of the defined axis.

FBD Language Example

Not available.

FFLD Language Example

Not available.

IL Language Example

Not available.

ST Language Example

Not available.

2.4.23 VLID



 **Function** - Gets the identifier (ID) of an embedded list of variables.

Inputs

Input	Data Type	Range	Unit	Default	Description
FILE	STRING				Pathname of the list file (.SPL or .TXT). Must be a constant value.

Outputs

Output	Data Type	Range	Unit	Description
ID	DINT			ID of the list. To be passed to other blocks.

Remarks

ⓘ IMPORTANT

List files are read at compiling time and are embedded into the downloaded application code. This implies that a modification performed in the list file after downloading is not taken into account by the application.

- This function is used to create an Identifier (ID) or ListID for a list of application variables that are typically stored on the development PC.
- The list of application variables:
 - Is a simple .TXT file.
 - Can contain only one variable name per line.
 - Can be only global variables (i.e., Internal variables known by all programs.)
- This function's ID output can be used as an input to "LogFileCSV" (→ p. 74).
 - It defines the application variables whose present value is recorded each time LogFileCSV is executed.

FBD Language Example

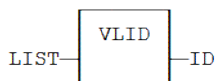

FFLD Language Example

The function is executed only if EN is TRUE.

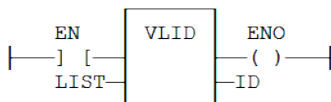

IL Language Example

```

Op1: LD   'MyFile.txt'
      VLID COL
      ST   ListID
  
```

ST Language Example

```

ID := VLID ('MyFile.spl');
  
```

2.5 PLC Advanced - Files

PLCopen 

These are the PLC Advanced File functions:

Name	Description
LogFileCSV	Create a log file in CSV format for a list of variables.
SD Card Mounting Functions	Mounting an SD card.

2.5.1 LogFileCSV

PLCopen 

 **Function Block** - Create a log file in CSV format for a list of variables.

Inputs

Input	Data Type	Range	Unit	Default	Description
LOG	BOOL				Variables are saved on any rising edge of this input.
RST	BOOL				Reset the contents of the CSV file.
LIST	DINT				ID of the list of variables to log (use VLID function).
PATH	STRING				Path name of the CSV file (PxMM flash memory, SD card, or Shared Directory).

Outputs

Output	Data Type	Range	Unit	Description
Q	BOOL			TRUE if the requested operation has been performed without error.
ERR	DINT			Error report for the last requested operation. 0 (zero) is OK.

Remarks

IMPORTANT

Calling this function can lead to missing several PLC cycles.
Files are opened and closed directly by the target's Operating System.
Opening some files may be dangerous for system safety and integrity.
The number of open files may be limited by the target system.

NOTE

- Opening a file may be unsuccessful (invalid path or file name, too many open files...). Your application has to process such error cases in a safe way.
- File management may be not available on some targets.
 - See the OEM instructions for more information about available features.
- Valid paths for storing files depend on the target implementation.
 - See the OEM instructions for more information about available paths.

- This function enables to log values of a list of variables in a CSV file.
 - On each rising edge of the LOG input, one more line of values is added to the file.
 - There is one column for each variable, as they are defined in the list.
- The list of variables is prepared using the KAS-IDE or a text editor.
 - Use the VLID function to get the identifier of the list.
- On a rising edge of the RST command, the file is emptied.
- When a LOG or RST command is requested, the Q output is set to TRUE if successful.
- In case of error, a report is given in the ERR output.
 - Possible error values are:
 - 1 = Cannot reset file on a RST command.
 - 2 = Cannot open file for data storing on a LOG command.
 - 3 = Embedded lists are not supported by the runtime.
 - 4 = Invalid list ID.
 - 5 = Error while writing to file.
- Combined with real time clock management functions, this block provides a very easy way to generate a periodical log file.

This example shows a list and a program that log values everyday at 14h23m (2:23 pm) (see **1**).

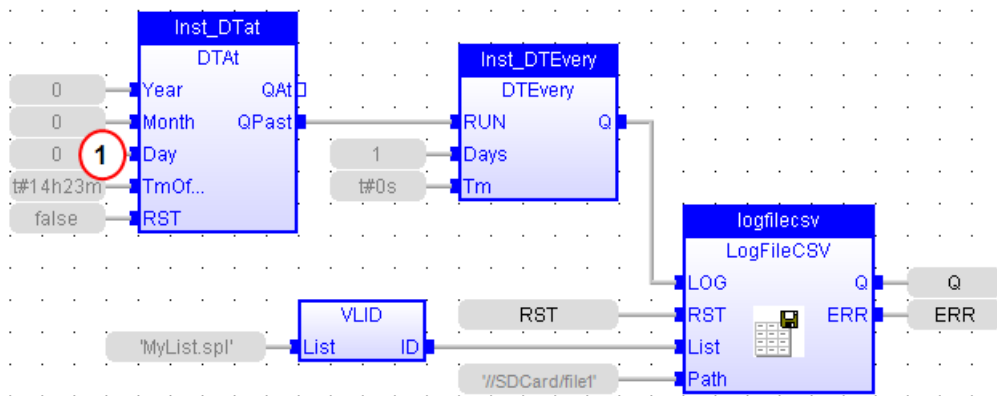

FBD Language Example

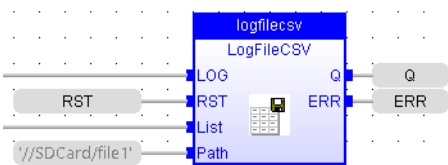

FPLD Language Example

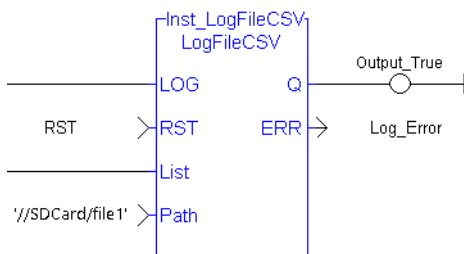

IL Language Example

```
(* MyLOG is a declared instance of LogFileCSV function block *)
Op1: CAL MyLOG (b_LOG, RST, LIST, PATH);
FFLD MyLOG.Q
ST Q
FFLD MyLog.ERR
ST ERR
```

ST Language Example

```
(* MyLOG is a declared instance of LogFileCSV function block *)
MyLOG (b_LOG, RST, LIST, PATH);
Q := MyLOG.Q;
ERR := MyLog.ERR;
```

See Also

VLID

2.5.2 SD Card Mounting Functions



Function - Mounting an SD card.

Name	Use
SD_ISREADY	Verify the SD card is mounted.
SD_MOUNT	Mount the SD card.
SD_UNMOUNT	Unmount the SD card.

2.5.2.1 SD_ISREADY

PLCopen - Verify the SD card is mounted.

Device	Action	Return Value	Example
AKD PDMM	Verify the SD card is mounted.	<ul style="list-style-type: none"> Mounted SD card = return value is TRUE. Unmounted SD card = return value is FALSE 	<pre>OK := SD_ISREADY ();</pre> <div style="border: 1px solid black; padding: 5px; margin-top: 10px;"> <p>OK : BOOL TRUE if the SD card is mounted.</p> </div>
PCMM2G	SD Card is not supported by PCMM2G. This does not perform any action.	It always returns FALSE.	

Device	Action	Return Value	Example
Simulator	Verify the SDCard folder exists here: C:\Users\[user's name]\AppData\Local\Kollmorgen\KAS\Sinope Simulator\Application\userdata\SDCard	<ul style="list-style-type: none"> • SDCard folder exists = return value is TRUE. • SDCard folder does not exist = return value is FALSE. 	<pre>OK := SD_ISREADY ();</pre> <p>OK : BOOL TRUE if the SDCard folder exists.</p>

2.5.2.2 SD_MOUNT

PLCopen  - Mount the SD card.

TIP

Recommended: Stop all motion before using SD_MOUNT.

Device	Action	Return Value	Example
AKD PDMM	Mount the SD card.	If the mount is successful, the return value is TRUE. If the mount is not successful, the return value is FALSE.	<pre>OK := SD_MOUNT ();</pre> <p>OK : BOOL TRUE if mounting the SD card is successful.</p>
PCMM2G	SD Card is not supported by PCMM2G. This does not perform any action.	It always returns FALSE.	
Simulator	This does not perform any action.	It always returns TRUE.	

2.5.2.3 SD_UNMOUNT

PLCopen  - Unmount the SD card.

TIP

Recommended: Stop all motion before using SD_UNMOUNT.

Device	Action	Return Value	Example
AKD PDMM	Unmount the SD card.	If the unmount is successful, the return value is TRUE. If the unmount is not successful, the return value is FALSE.	<pre>OK := SD_UNMOUNT ();</pre> <p>OK : BOOL TRUE if unmounting the SD card is successful.</p>
PCMM2G	SD Card is not supported by PCMM2G. This does not perform any action.	It always returns FALSE.	
Simulator	This does not perform any action.	It always returns TRUE.	

2.6 PID



Function Block - PID loop.

Inputs

Input	Data Type	Range	Unit	Default	Description
AUTO	BOOL				<ul style="list-style-type: none"> TRUE = normal mode FALSE = manual mode
DEADB_ERR	REAL				Hysteresis on PV. PV is considered as unchanged if it is both: <ul style="list-style-type: none"> Greater than (PVprev - DEADBAND_W). Less than (PRprev + DEADBAND_W).
FFD	REAL				Disturbance value on output.
I_ITL_ON	BOOL				If TRUE, the integrated value is reset to I_ITLVAL.
I_ITLVAL	REAL				Reset value for integration when I_ITL_ON is TRUE.
I_SEL	BOOL				If FALSE, the integrated value is ignored.
INT_HOLD	BOOL				If TRUE, the integrated value is frozen.
KP	REAL				Gain.
PV	REAL				Process value.
SP	REAL				Set point.
TD	REAL				Derivation factor.
TI	REAL				Integration factor.
TS	TIME				Sampling period.
XMAX	REAL				Maximum output value.
XMIN	REAL				Minimum allowed output value.
Xout_Manu	REAL				Output value in manual mode.

Outputs

Output	Data Type	Range	Unit	Description
ER	REAL			Last calculated error.
Xout	REAL			Output command value.
Xout_D	REAL			Last calculated derivated value.
Xout_HLM	BOOL			TRUE if the output value is saturated to XMAX.
Xout_I	REAL			Last calculated integrated value.
Xout_LLM	BOOL			TRUE if the output value is saturated to XMIN.
Xout_P	REAL			Last calculated proportional value.

Remarks

- It is important for the stability of the control that the TS sampling period is much bigger than the cycle time.
- Output of the PID block always starts with zero.
 - The value varies per the inputs provided upon further cycle executions.

2.6.0.1 Diagram

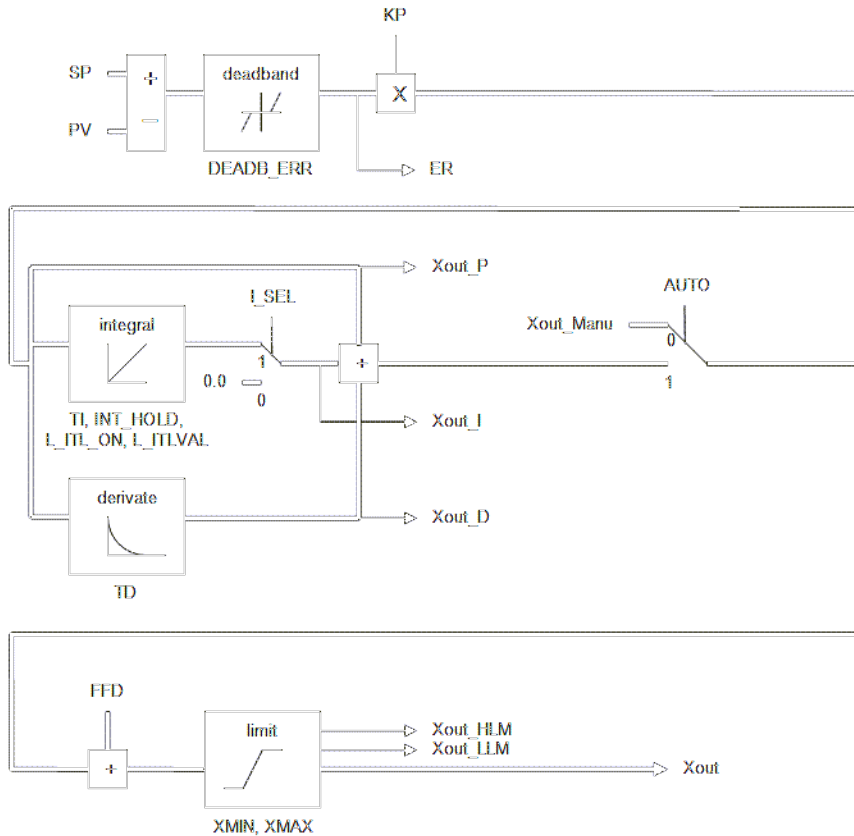

FBD Language Example

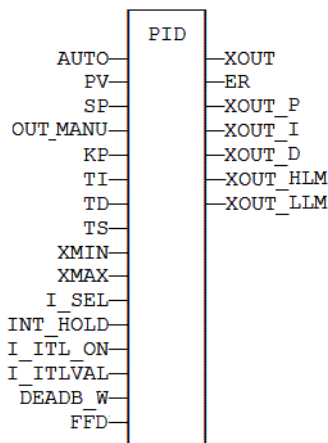

FFLD Language Example

- In the FFLD Language, the output rung has the same value as the AUTO input, corresponding to the input rung.
- ENO has the same state as the input rung.

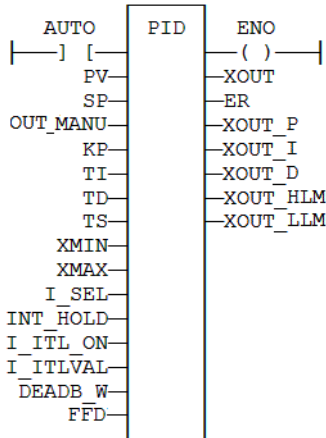

IL Language Example

```
(* MyPID is a declared instance of PID function block. *)
Op1:   CAL MyPID (AUTO, PV, SP, XOUT_MANU, KP, TI, TD, TS, XMIN, XMAX, I_SEL,
I_ITL_ON, I_ITLVAL, DEADB_ERR, FFD)
      FFLD MyPID.XOUT
      ST  XOUT
      FFLD MyPID.ER
      ST  ER
      FFLD MyPID.XOUT_P
      ST  XOUT_P
      FFLD MyPID.XOUT_I
      ST  XOUT_I
      FFLD MyPID.XOUT_D
      ST  XOUT_D
      FFLD MyPID.XOUT_HLM
      ST  XOUT_HLM
      FFLD MyPID.XOUT_LLM
      ST  XOUT_LLM
```

ST Language Example

```
(* MyPID is a declared instance of PID function block. *)
MyPID (AUTO, PV, SP, XOUT_MANU, KP, TI, TD, TS, XMIN, XMAX, I_SEL, I_ITL_ON,
I_ITLVAL, DEADB_ERR, FFD);
XOUT := MyPID.XOUT;
ER := MyPID.ER;
XOUT_P := MyPID.XOUT_P;
XOUT_I := MyPID.XOUT_I;
XOUT_D := MyPID.XOUT_D;
XOUT_HLM := MyPID.XOUT_HLM;
XOUT_LLM := MyPID.XOUT_LLM;
```

3 PLC Standard Libraries

3.1 Programming Languages

3.2 Programming Features

These topics detail programming features and standard blocks:

- "PLC Advanced Libraries" (→ p. 31)
- "Arithmetic Operations" (→ p. 81)
- "Basic Operations" (→ p. 96)
- "Boolean Operations" (→ p. 111)
- "Comparison Operations" (→ p. 160)
- "Counters" (→ p. 186)
- "Mathematic Operations" (→ p. 190)
- "Registers" (→ p. 206)
- "Selectors" (→ p. 233)
- "String Operations" (→ p. 250)
- "Timers" (→ p. 273)
- "Trigonometric Functions" (→ p. 287)
- "Conversion Functions" (→ p. 169)

NOTE

Some other functions not documented are reserved for diagnostics and special operations. Contact Kollmorgen technical support for more information.

3.3 Arithmetic Operations



- "All Functions and Operators (Alphabetically)" (→ p. 81)
 - "Standard Functions" (→ p. 82)
 - "Standard Operators" (→ p. 82)

3.3.1 All Functions and Operators (Alphabetically)

Name	Description
Addition +	Performs an addition of all inputs.
Divide /	Performs a division of all inputs.
limit	Limits a numeric value between low and high bounds.
max	Get the maximum of two integers.
min	Get the minimum of two integers.
mod / modLR / modR	Calculation of modulo.
Multiply *	Performs a multiplication of all inputs.
NEG -	Performs a negation of the input. (unary operator)
odd	Test if an integer is odd.
SetWithin	Force a value when inside an interval.
Subtraction -	Performs a subtraction of all inputs.

3.3.1.1 Standard Functions

These are arithmetic functions.

Name	Description
limit	Limits a numeric value between low and high bounds.
max	Get the maximum of two integers.
min	Get the minimum of two integers.
mod / modLR / modR	Calculation of modulo.
odd	Test if an integer is odd.
SetWithin	Force a value when inside an interval.

3.3.1.2 Standard Operators

These are the arithmetic operators.

Name	Description
Addition +	Performs an addition of all inputs.
Divide /	Performs a division of all inputs.
Multiply *	Performs a multiplication of all inputs.
NEG -	Performs a negation of the input. (unary operator)
Subtraction -	Performs a subtraction of all inputs.

3.3.2 Addition +

Operator - Performs an addition of all inputs.

Inputs

Input	Data Type	Range	Unit	Default	Description
IN1	ANY				First input.
IN2	ANY				Second input.

Outputs

Output	Data Type	Range	Unit	Description
Q	ANY			Result: IN1 + IN2.

Remarks

- All inputs and the output must have the same type.
- The addition can be used with strings.
 - The result is the concatenation of the input strings.

FBD Language Example

- In the FBD Language, the block can have a maximum of 32 inputs.

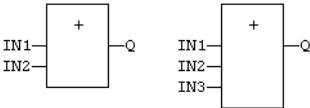

FFLD Language Example

- In the FFLD Language, the input rung (EN) enables the operation.
 - The output rung (ENO) keeps the same value as the input rung.

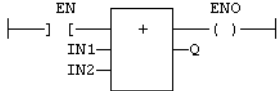

IL Language Example

- In the IL Language, the **ADD** instruction performs an addition between the current result and the operand.
 - The current result and the operand must have the same type.

```
Op1: FFLD IN1
      ADD IN2
      ST Q    (* Q is equal to: IN1 + IN2 *)
Op2: FFLD IN1
      ADD IN2
      ADD IN3
      ST Q    (* Q is equal to: IN1 + IN2 + IN3 *)
```

ST Language Example

```
Q := IN1 + IN2;
MyString := 'He' + 'll ' + 'o';    (* MyString is equal to 'Hello' *)
```

See Also

- Divide /
- Multiply
- Subtraction -

3.3.3 Divide /

Operator - Performs a division of all inputs.

Inputs

Input	Data Type	Range	Unit	Default	Description
IN1	ANY_NUM				First input.
IN2	ANY_NUM				Second input.

Outputs

Output	Data Type	Range	Unit	Description
Q	ANY_NUM			Result: IN1 / IN2.

Remarks

- All inputs and the output must have the same type.

FBD Language Example

- In the FBD Language, the block can have a maximum of 32 inputs.

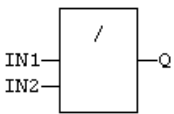

FFLD Language Example

- In the FFLD Language, the input rung (EN) enables the operation.
 - The output rung (ENO) keeps the same value as the input rung.

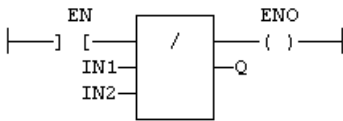

IL Language Example

- In the IL language, the **DIV** instruction performs a division between the current result and the operand.
 - The current result and the operand must have the same type.

```
Op1: FFLD IN1
      DIV IN2
      ST Q    (* Q is equal to: IN1 / IN2 *)

Op2: FFLD IN1
      DIV IN2
      DIV IN3
      ST Q    (* Q is equal to: IN1 / IN2 / IN3 *)
```

ST Language Example

```
Q := IN1 / IN2;
```

See Also

- Addition +
- Multiply
- Subtraction -

3.3.4 NEG -



Operator - Performs a negation of the input. (unary operator)

Inputs

Input	Data Type	Range	Unit	Default	Description
IN	ANY				Numeric value.

Outputs

Output	Data Type	Range	Unit	Description
Q	ANY			Negation of the input.

Remarks

- In FBD and FFLD language, the block **NEG** can be used.

Truth Table

IN	Q
0	0
1	-1
-123	123

FBD Language Example



FFLD Language Example

- In the FFLD Language, the conversion is executed only if the input rung (EN) is TRUE.
 - The output rung (ENO) keeps the same value as the input rung.
 - The negation is executed only if EN is TRUE.
 - ENO keeps the same value as EN.

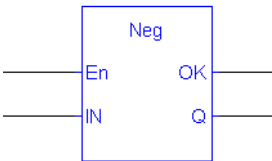

IL Language Example

Not available.

ST Language Example

- In the ST Language, - (hyphen) can be followed by a complex Boolean expression between parentheses.
 - The output data type must be the same as the input data type.

```
Q := -IN;
Q := - (IN1 + IN2);
```

3.3.5 limit

PLCopen 



Function - Limits a numeric value between low and high bounds.

Inputs

Input	Data Type	Range	Unit	Default	Description
IMIN	DINT				Low bound.
IN	DINT				Input value.
IMAX	DINT				High bound.

Outputs

Output	Data Type	Range	Unit	Description
Q	DINT			IMIN if IN < IMIN; IMAX if IN > IMAX; IN otherwise.

Remarks

None

3.3.5.0.1 Function Diagram

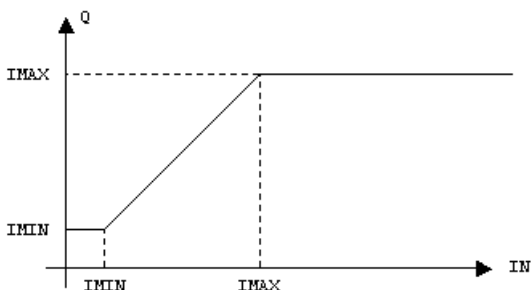

FBD Language Example

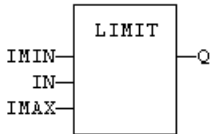

FFLD Language Example

- In the FFLD Language, the input rung (EN) enables the operation.
 - The output rung keeps the state of the input rung.
 - The comparison is executed only if EN is TRUE.
 - ENO has the same value as EN.

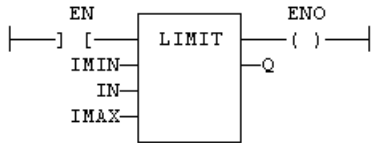

IL Language Example

- In the IL Language, the first input must be loaded before the function call.
 - Other inputs are operands of the function, separated by comas.

```
Op1: LD    IMIN
      LIMIT IN, IMAX
      ST    Q
```

ST Language Example

```
Q := LIMIT (IMIN, IN, IMAX);
```

See Also

- max
- min
- mod / modLR / modR
- odd

3.3.6 max



Function - Get the maximum of two integers.

Inputs

Input	Data Type	Range	Unit	Default	Description
IN1	ANY				First input.
IN2	ANY				Second input.

Outputs

Output	Data Type	Range	Unit	Description
Q	ANY			IN1 if IN1 > IN2; IN2 otherwise.

Remarks

None

FBD Language Example

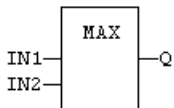

FFLD Language Example

- In the FFLD Language, the input rung (EN) enables the operation.
 - The output rung keeps the state of the input rung.
 - The comparison is executed only if EN is TRUE.
 - ENO has the same value as EN.

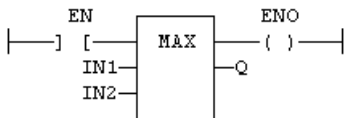

IL Language Example

- In the IL Language, the first input must be loaded before the function call.
 - The second input is the operand of the function.

```
Op1: LD  IN1
      MAX IN2
      ST  Q    (* Q is the maximum of IN1 and IN2 *)
```

ST Language Example

```
Q := MAX (IN1, IN2);
```

See Also

- "limit" (→ p. 86)
- "min" (→ p. 88)
- "mod / modLR / modR" (→ p. 90)
- "odd" (→ p. 92)

3.3.7 min



Function - Get the minimum of two integers.

Inputs

Input	Data Type	Range	Unit	Default	Description
IN1	ANY				First input.
IN2	ANY				Second input.

Outputs

Output	Data Type	Range	Unit	Description
Q	ANY			IN1 if IN1 < IN2; IN2 otherwise.

Remarks

None

FBD Language Example

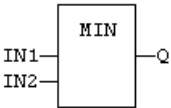

FFLD Language Example

- In the FFLD Language, the input rung (EN) enables the operation.
 - The output rung keeps the state of the input rung.
 - The comparison is executed only if EN is TRUE.
 - ENO has the same value as EN.

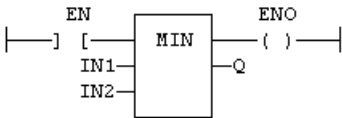

IL Language Example

- In the IL Language, the first input must be loaded before the function call.
 - The second input is the operand of the function.

```
Op1: LD IN1
      MIN IN2
      ST Q      (* Q is the minimum of IN1 and IN2 *)
```

ST Language Example

```
Q := MIN (IN1, IN2);
```

See Also

- "limit" (→ p. 86)
- "max" (→ p. 87)
- "mod / modLR / modR" (→ p. 90)
- "odd" (→ p. 92)

3.3.8 mod / modLR / modR



Function - Calculation of modulo.

Inputs

Input	Data Type	Range	Unit	Default	Description
IN	mod = DINT				Input value.
	modR = REAL				
	modLR = LREAL				
BASE	mod = DINT				Base of the modulo.
	modR = REAL				
	modLR = LREAL				

Outputs

Output	Data Type	Range	Unit	Description
Q	mod = DINT modR = REAL modLR = LREAL			Modulo: rest of the integer division (IN / BASE).

Remarks

None

FBD Language Example

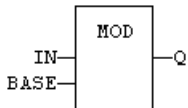

FFLD Language Example

- In the FFLD Language, the input rung (EN) enables the operation.
 - The output rung keeps the state of the input rung.
 - The comparison is executed only if EN is TRUE.
 - ENO has the same value as EN.

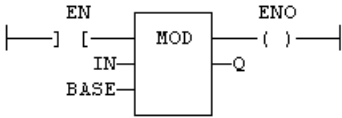

IL Language Example

- In the IL Language, the first input must be loaded before the function call.
 - The second input is the operand of the function.

```
Op1: LD IN
      MOD BASE
      ST Q (* Q is the rest of integer division: IN / BASE *)
```

ST Language Example

```
Q := MOD (IN, BASE);
```

See Also

- "limit" (→ p. 86)
- "max" (→ p. 87)
- "min" (→ p. 88)
- "odd" (→ p. 92)

3.3.9 Multiply

Operator - Performs a multiplication of all inputs.

Inputs

Input	Data Type	Range	Unit	Default	Description
IN1	ANY_NUM				First input.
IN2	ANY_NUM				Second input.

Outputs

Output	Data Type	Range	Unit	Description
Q	ANY_NUM			Result: IN1 * IN2.

Remarks

- All inputs and the output must have the same type.

FBD Language Example

- In the FBD Language, the block can have a maximum of 32 inputs.

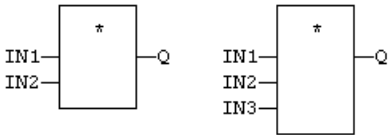

FFLD Language Example

- The multiplication is executed only if EN is TRUE.
- In the FFLD Language, the input rung (EN) enables the operation.
 - The output rung (ENO) keeps the same value as the input rung.
- ENO is equal to EN.

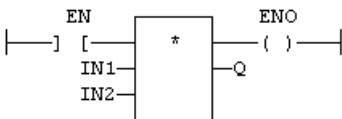

IL Language Example

- In the IL Language, the **MUL** instruction performs a multiplication between the current result and the operand.
 - The current result and the operand must have the same type.

```
Op1: FFLD IN1
      MUL IN2
      ST Q   (* Q is equal to: IN1 * IN2 *)

Op2: FFLD IN1
      MUL IN2
      MUL IN3
      ST Q   (* Q is equal to: IN1 * IN2 * IN3 *)
```

ST Language Example

```
Q := IN1 * IN2;
```

See Also

- Addition +
- Divide /
- Subtraction -

3.3.10 odd



Function - Test if an integer is odd.

Inputs

Input	Data Type	Range	Unit	Default	Description
IN	DINT				Input value.

Outputs

Output	Data Type	Range	Unit	Description
Q	BOOL			<ul style="list-style-type: none"> • TRUE if IN is odd. • FALSE if IN is even.

Remarks

None

FBD Language Example

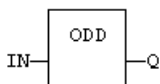

FFLD Language Example

- In the FFLD Language, the input rung (EN) enables the operation.
 - The output rung keeps the state of the input rung.
 - The function is executed only if EN is TRUE.

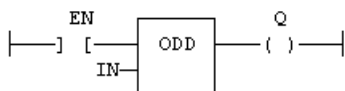

IL Language Example

- In the IL Language, the first input must be loaded before the function call.
 - The second input is the operand of the function.

```
Op1: LD  IN
      ODD
      ST  Q    (* Q is TRUE if IN is odd. *)
```

ST Language Example

```
Q := ODD (IN);
```

See Also

- "limit" (→ p. 86)
- "max" (→ p. 87)
- min
- "mod / modLR / modR" (→ p. 90)

3.3.11 SetWithin



 **Function** - Force a value when inside an interval.

Inputs

Input	Data Type	Range	Unit	Default	Description
IN	ANY				Input.
MIN	ANY				Low limit of the interval.
MAX	ANY				High limit of the interval.
VAL	ANY				Value to apply when inside the interval.

Outputs

Output	Data Type	Range	Unit	Description
Q	ANY			Result.

Remarks

- The output is forced to VAL when the IN value is within the [MIN ... MAX] interval.
- It is set to IN when outside the interval.

Truth Table

In	Q
IN < MIN	IN
IN > MAX	IN
MIN < IN < MAX	VAL

FBD Language Example

Not available.

FFLD Language Example

Not available.

IL Language Example

Not available.

ST Language Example

Not available.

3.3.12 Subtraction -

Operator - Performs a subtraction of all inputs.

Inputs

Input	Data Type	Range	Unit	Default	Description
IN1	ANY_NUM / TIME				First input.
IN2	ANY_NUM / TIME				Second input.

Outputs

Output	Data Type	Range	Unit	Description
Q	ANY_NUM / TIME			Result: IN1 - IN2.

Remarks

- All inputs and the output must have the same type.

FBD Language Example

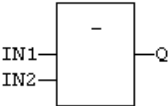

FFLD Language Example

- In the FFLD Language, the input rung (EN) enables the operation.
 - The output rung (ENO) keeps the same value as the input rung.
 - The subtraction is executed only if EN is TRUE.
 - ENO is equal to EN.

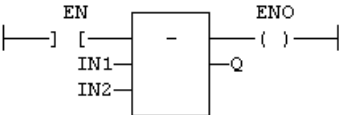

IL Language Example

- In the IL Language, the **SUB** instruction performs a subtraction between the current result and the operand.
 - The current result and the operand must have the same type.

```
Op1: FFLD IN1
      SUB IN2
      ST Q    (* Q is equal to: IN1 - IN2 *)
Op2: FFLD IN1
      SUB IN2
      SUB IN3
      ST Q    (* Q is equal to: IN1 - IN2 - IN3 *)
```

ST Language Example

```
Q := IN1 - IN2;
```

See Also

- Addition +
- Divide /
- Multiply

3.4 Basic Operations

3.4.1 Data Manipulation

These are the language features for basic data manipulation:

- "Assignment :=" (→ p. 97) - Variable assignment.
- "Bit Access" (→ p. 98)
- Function Call
- Call a Function Block
- "Call a Sub-Program" (→ p. 99)
- "CountOf" (→ p. 242) - Returns the number of items in an array.
- "DEC" (→ p. 243) - Decrease a numerical variable.
- "INC" (→ p. 244) - Increase a numerical variable.
- "MoveBlock" (→ p. 246) - Move / Copy items of an array.
- "NEG -" (→ p. 247) Performs a negation of the input. (unary operator)
- "Parenthesis ()" (→ p. 105) - Force the evaluation order in a complex expression.

3.4.2 Control Program Execution

3.4.2.1 Language Features

These are the language features to control program execution:

- Jumps JMP JMPN JMPNC JMPNCN
- LABELS
- "RETURN RET RETC RETNC RETCN" (→ p. 107)

3.4.2.2 Structured Statements

These are the structured statements to control program execution:

Statement	Description
"CASE OF ELSE END_CASE" (→ p. 100)	Switch to one of various possible statements.
"EXIT" (→ p. 101)	Exit from a loop instruction.
"FOR TO BY END_FOR" (→ p. 102)	Execute iterations of statements.
"IF THEN ELSE ELSIF END_IF" (→ p. 103)	Conditional execution of statements.
"ON" (→ p. 104)	Conditional execution of statements.
"REPEAT UNTIL END_REPEAT" (→ p. 106)	Repeat a list of statements.
"WAIT / WAIT_TIME" (→ p. 109)	Suspends the execution of an ST program.
"WHILE DO END_WHILE" (→ p. 110)	Repeat a list of statements while a condition is TRUE.

3.4.3 Assignment :=



Operator - Variable assignment.

Inputs

Input	Data Type	Range	Unit	Default	Description
IN	ANY				Any variable or complex expression.

Outputs

Output	Data Type	Range	Unit	Description
Q	ANY			Forced variable.

Remarks

- The output variable and the input expression must have the same type.
- The forced variable cannot have the read-only attribute.
- In the FBD and FFLD languages, the 1 block is available to perform a 1 gain data copy (1 copy).
- In the IL Language:
 - The FFLD instruction loads the first operand.
 - The ST instruction stores the current result into a variable.
 - The current result and the operand of ST must have the same type.
- Both FFLD and ST instructions can be modified by N in case of a Boolean operand for performing a Boolean negation.

FBD Language Example



FFLD Language Example

- In the FFLD Language, the input rung (EN) enables the assignment.
 - The output rung keeps the state of the input rung.
- The copy is executed only if EN is TRUE.
- ENO has the same value as EN.

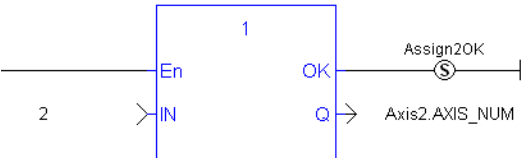

IL Language Example

```
Op1: FFLD IN    (* current result is: IN *)
      ST Q      (* Q is: IN *)
      FFLDN IN1 (* current result is: NOT (IN1) *)
      ST Q      (* Q is: NOT (IN1) *)
      FFLD IN2  (* current result is: IN2 *)
      STN Q     (* Q is: NOT (IN2) *)
```

ST Language Example

```
Q := IN; (* copy IN into variable Q *)
      Q := (IN1 + (IN2 / IN 3)) * IN4; (* assign the result of a complex
expression *)
      result := SIN (angle); (* assign a variable with the result of a
function *)
      time := MyTon.ET; (* assign a variable with an output parameter of
a function block *)
```

See Also

Parenthesis ()

3.4.4 Bit Access

You can directly specify a bit within an integer variable in expressions and diagrams using this notation:

```
Variable.BitNo
```

Where:

Variable: is the name of an integer variable.

BitNo: is the number of the bit in the integer.



The variable can have one of these data types:

Bits	Data Type
8-bits from .0 to .7	BYTE, SINT, USINT
16-bits from .0 to .15	INT, UINT, DWORD
32-bits from .0 to 31	DINT, DWORD, UDINT
64-bits from .0 to .63	LINT, LWORD, ULINT

0 (zero) always represents the less significant bit.

3.4.5 Differences between Functions and Function Blocks

It is important to clearly understand what is different between functions and function blocks.

- A  **Function** is called once and it performs an action.
 - This is synchronous.
- A  **Function Block (FB)** is an instance that has its own set of data.
 - An FB maintains its own, internal machine state and often has an output to indicate when the work is done.

- An FB is asynchronous.
- The best way to work with a function block is to call it during multiple scan.
 - This triggers the action the first time, then monitor the status of this action, especially via the Done output.

See Also

- Call a Function
- Call a Function Block

3.4.6 Call a Sub-Program

A sub-program is called by another program.

- Unlike function blocks, local variables of a sub-program are not instantiated and you do not need to declare instances.
- A call to a sub-program processes the block algorithm using the specified input parameters.
- Output parameters can then be accessed.

3.4.6.1 FBD and FFLD Languages

To call a sub-program in FBD or FFLD languages, insert the block in the diagram and connect its inputs and outputs.

IL Language Example

To call a sub-program in the IL language, you must use the CAL instruction with the name of the sub-program, followed by the input parameters written between parentheses and separated by comas.

Alternatively, the CALC, CALCN or CALNC conditional instructions can be used:

```
CAL    Calls the sub-program
CALC   Calls the sub-program if the current result is TRUE
CALNC  Calls the sub-program if the current result is FALSE
CALCN  same as CALNC
```

Example

```
Op1: CAL  MySubProg (i1, i2)
FFLD  MySubProg.Q1
ST  Res1
FFLD  MySubProg.Q2
ST  Res2
```

ST Language Example

To call a sub-program in ST, you must specify its name, followed by the input parameters written between parentheses and separated by comas.

To have access to an output parameter, use the name of the sub-program followed by a dot . and the name of the parameter:

```
MySubProg (i1, i2); (* calls the sub-program *)
Res1 := MySubProg.Q1;
Res2 := MySubProg.Q2;
```

Alternatively, if a sub-program has one and only one output parameter, it can be called as a function in ST language:

```
Res := MySubProg (i1, i2);
```

3.4.7 CASE OF ELSE END_CASE

Statement - Switch to one of various possible statements.

3.4.7.1 Syntax

```
CASE <DINT expression> OF
<value> :
    <statements>
<value> , <value> :
    <statements>;
<value> .. <value> :
    <statements>;
ELSE
    <statements>
END_CASE;
```

Remarks

- All enumerated values correspond to the evaluation of the DINT expression and **are possible cases** in the execution of the statements.
- The statements specified after the ELSE keyword are executed if the expression takes a value which is not enumerated in the switch.
- For each case, you must specify either:
 - a value.
 - a list of possible values separated by comas (,).
 - a range of values specified by a "min .. max" interval.
- You must enter space characters before and after the ".." separator.

FBD Language Example

Not available.

FFLD Language Example

Not available.

IL Language Example

Not available.

ST Language Example

```
(* This example check first prime numbers: *)
CASE iNumber OF
0 :
```

```

    Alarm := TRUE;
    AlarmText := '0 gives no result';
1 .. 3, 5 :
    bPrime := TRUE;
4, 6 :
    bPrime := FALSE;
ELSE
    Alarm := TRUE;
    AlarmText := 'I don't know after 6 !';
END_CASE;

```

See Also

- EXIT
- "FOR TO BY END_FOR" (→ p. 102)
- "IF THEN ELSE ELSIF END_IF" (→ p. 103)
- "REPEAT UNTIL END_REPEAT" (→ p. 106)
- "WHILE DO END_WHILE" (→ p. 110)

3.4.8 EXIT

Statement - Exit from a loop instruction.

Remarks

- The EXIT statement indicates that the current loop (FOR, REPEAT, or WHILE) must be finished.
- The execution continues after the END_FOR, END_REPEAT, or END_WHILE keyword or the loop where the EXIT is.
- EXIT quits only one loop and cannot be used to exit at the same time several levels of nested loops.

ⓘ IMPORTANT

Loop instructions can lead to infinite loops that block the target cycle.

FBD Language Example

Not available.

FFLD Language Example

Not available.

IL Language Example

Not available.

ST Language Example

```

(* This program searches for the first non null item of an array: *)
iFound = -1; (* means: not found *)
FOR iPos := 0 TO (iArrayDim - 1) DO
    IF iPos <> 0 THEN

```

```

        iFound := iPos;
        EXIT;
    END_IF;
END_FOR;

```

See Also

- "CASE OF ELSE END_CASE" (→ p. 100)
- "FOR TO BY END_FOR" (→ p. 102)
- "IF THEN ELSE ELSIF END_IF" (→ p. 103)
- "REPEAT UNTIL END_REPEAT" (→ p. 106)
- "WHILE DO END_WHILE" (→ p. 110)

3.4.9 FOR TO BY END_FOR

Statement - Execute iterations of statements.

3.4.9.1 Syntax

```

FOR <index> := <minimum> TO <maximum>
BY <step> DO
    <statements>
END_FOR;

```

index = DINT internal variable used as **index**.

minimum = DINT expression: initial value for **index**.

maximum = DINT expression: maximum allowed value for **index**.

step = DINT expression: increasing step of **index** after each iteration (default is 1) .

Remarks

- The BY <step> statement can be omitted.
- The default value for the step is 1.

FBD Language Example

Not available.

FFLD Language Example

Not available.

IL Language Example

Not available.

ST Language Example

```

iArrayDim := 10;

(* resets all items of the array to 0 *)
FOR iPos := 0 TO (iArrayDim - 1) DO
    MyArray[iPos] := 0;
END_FOR;

(* set all items with odd index to 1 *)
FOR iPos := 1 TO 9 BY 2 DO
    MyArray[iPos] := 1;
END_FOR;

```

See Also

- "CASE OF ELSE END_CASE" (→ p. 100)
- "EXIT" (→ p. 101)
- "IF THEN ELSE ELSIF END_IF" (→ p. 103)
- "REPEAT UNTIL END_REPEAT" (→ p. 106)
- "REPEAT UNTIL END_REPEAT" (→ p. 106)
- "WHILE DO END_WHILE" (→ p. 110)

3.4.10 IF THEN ELSE ELSIF END_IF

Statement - Conditional execution of statements.

3.4.10.1 Syntax

```

IF <BOOL expression> THEN
    <statements>
ELSIF <BOOL expression> THEN
    <statements>
ELSE
    <statements>
END_IF;

```

Remarks

- The IF statement is available in ST only.
- The execution of the statements is conditioned by a Boolean expression.
- ELSIF and ELSE statements are optional.
- There can be several ELSIF statements.

FBD Language Example

Not available.

FFLD Language Example

Not available.

IL Language Example

Not available.

ST Language Example

```
(* simple condition *)  
  
IF bCond THEN  
    Q1 := IN1;  
    Q2 := TRUE;  
END_IF;  
  
(* binary selection *)  
  
IF bCond THEN  
    Q1 := IN1;  
    Q2 := TRUE;  
ELSE  
    Q1 := IN2;  
    Q2 := FALSE;  
END_IF;  
  
(* enumerated conditions *)  
  
IF bCond1 THEN  
    Q1 := IN1;  
ELSIF bCond2 THEN  
    Q1 := IN2;  
ELSIF bCond3 THEN  
    Q1 := IN3;  
ELSE  
    Q1 := IN4;  
END_IF;
```

See Also

- "CASE OF ELSE END_CASE" (→ p. 100)
- "EXIT" (→ p. 101)
- "FOR TO BY END_FOR" (→ p. 102)
- "REPEAT UNTIL END_REPEAT" (→ p. 106)
- "WHILE DO END_WHILE" (→ p. 110)

3.4.11 ON

Statement - Conditional execution of statements.

3.4.11.1 Syntax

```
ON <BOOL expression> DO  
    <statements>  
END_DO;
```

Remarks

⚠ CAUTION

This instruction is NOT UDFB safe.
Do not use inside UDFBs.

- The **ON** instruction:
 - Provides a simpler syntax for checking the rising edge of a Boolean condition.
 - Avoids systematic use of the R_TRIG function block or other "last state" flags.
- Statements within the **ON** structure are executed only when the Boolean expression rises from FALSE to TRUE.
- The **ON** syntax is available in any program or sub-program.
- This statement is an extension to the standard and is NOT IEC 61131-3 compliant.

FBD Language Example

Not available.

FPLD Language Example

Not available.

IL Language Example

Not available.

ST Language Example

```
(* This example counts the rising edges of variable bIN *)
ON bIN DO
    diCount := diCount + 1;
END_DO;
```

3.4.12 Parenthesis ()

Operator - Force the evaluation order in a complex expression.

Remarks

- Parentheses are used in ST and IL languages for changing the default evaluation order of various operations within a complex expression.
- Example: The default evaluation of $2 * 3 + 4$ expression in ST Language gives a result of 10 because * operator has the highest priority.
 - Changing the expression as $2 * (3 + 4)$ gives a result of 14.
- Parentheses can be nested in a complex expression.

These are the default evaluation priority order for ST language operations:

Priority	Operation	Description
1	- NOT	Unary operators
2	* /	Multiply / Divide
3	+ -	Add / Subtract

Priority	Operation	Description
4	< > <= > = <>	Comparisons
5	& AND	Boolean And
6	OR	Boolean Or
7	XOR	Exclusive OR

FBD Language Example

Not available.

FFLD Language Example

Not available.

IL Language Example

- In the IL Language:
 - The default order is the sequence of instructions.
 - Each new instruction modifies the current result sequentially.
 - The opening parenthesis "(" is written between the instruction and its operand.
 - The closing parenthesis ")" must be written alone as an instruction without operand.

```
Op1: FFLD( IN1
      ADD( IN2
      MUL IN3
      )
      SUB IN4
      )
      ST Q (* Q is: (IN1 + (IN2 * IN3) - IN4) *)
```

ST Language Example

```
Q := (IN1 + (IN2 / IN 3)) * IN4;
```

See Also

Assignment :=

3.4.13 REPEAT UNTIL END_REPEAT

Statement - Repeat a list of statements.

3.4.13.1 Syntax

```
REPEAT
  <statements>
UNTIL <BOOL expression>
END_REPEAT;
```

Remarks

- The statements between `REPEAT` and `UNTIL` are executed until the Boolean expression is `TRUE`.
- The condition is evaluated **after** the statements are executed.
 - Statements are executed at least once.

ⓘ IMPORTANT

Loop instructions can lead to infinite loops that block the target cycle.
Never test the state of an input in the condition because the input is not refreshed before the next cycle.

FBD Language Example

Not available.

FFLD Language Example

Not available.

IL Language Example

Not available.

ST Language Example

```
iPos := 0;
REPEAT
  MyArray[iPos] := 0;
  iNbCleared := iNbCleared + 1;
  iPos := iPos + 1;
UNTIL iPos = iMax
END_REPEAT;
```

See Also

- "CASE OF ELSE END_CASE" (→ p. 100)
- "EXIT" (→ p. 101)
- "FOR TO BY END_FOR" (→ p. 102)
- "IF THEN ELSE ELSIF END_IF" (→ p. 103)
- "WHILE DO END_WHILE" (→ p. 110)

3.4.14 RETURN RET RETC RETNC RETCN

Statement - Jump to the end of the program.

Remarks

- When used within an action block of a SFC step, the `RETURN` statement jumps to the end of the action block.

FBD Language Example

- The return statement is represented by the <RETURN> symbol.
 - The input of the symbol must be connected to a valid Boolean signal.
 - The jump is performed only if the input is TRUE.

In this example, the TON block will not be called if bIgnore is TRUE.

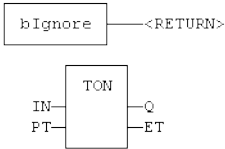

FFLD Language Example

- The <RETURN> symbol is used as a coil at the end of a rung.
 - The jump is performed only if the rung state is TRUE.

In this example, all the networks above 5 are skipped if ENABLE is FALSE.

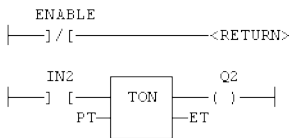

IL Language Example

These are the meanings of possible instructions:

- RET Jump to the end always.
- RETC Jump to the end if the current result is TRUE.
- RETNC Jump to the end if the current result is FALSE.
- RETCN Same as RETNC.

```

Start: FFLD    IN1
      RETC      (* Jump to the end if IN1 is TRUE *)

      FFLD    IN2  (* these instructions are not executed *)
      ST      Q2  (* if IN1 is TRUE *)
      RET      (* Jump to the end unconditionally *)

      FFLD    IN3  (* these instructions are never executed *)
      ST      Q3
    
```

ST Language Example

```

IF NOT bEnable THEN
  RETURN;
END_IF;
(* the rest of the program is not executed if bEnable is FALSE *)
    
```

See Also

- Jumps JMP JMPC JMPNC JMPCN
- LABELS

3.4.15 WAIT / WAIT_TIME

Statement - Suspends the execution of an ST program.

3.4.15.1 Syntax

```
WAIT<BOOL expression> ;
```

```
WAIT_TIME<TIME expression> ;
```

Remarks

- The `WAIT` statement:
 - Provides an easy way to program a state machine.
 - This avoids the use of complex `CASE` structures.
 - Verifies the attached Boolean expression and takes these actions:
 - If the expression is `TRUE`, the program continues normally.
 - If the expression is `FALSE`, then the execution of the program is suspended up to the **next PLC cycle**. The Boolean expression will be checked again during next cycles until it becomes `TRUE`. The execution of other programs is not affected.
- The `WAIT_TIME` statement suspends the execution of the program for the specified duration.
 - The execution of other programs is not affected.

These instructions are available in ST Language only and have no correspondence in other languages.

- The `WAIT` and `WAIT_TIME` instructions:
 - Cannot be called in a User-Defined Function Block (UDFB).
 - The use of `WAIT` or `WAIT_TIME` in a UDFB provokes a compile error.
 - Can be called in a sub-program.
 - However, it can lead to some unsafe situation if the same sub program is called from various programs.
 - Do not support re-entrancy.
 - Avoiding this situation is the responsibility of the programmer.
 - The compiler outputs some warning messages if a sub-program containing a `WAIT` or `WAIT_TIME` instruction is called from more than one program.
 - Must not be called from ST parts of SFC programs.
 - This makes no sense as SFC is already a state machine.
 - The use of `WAIT` or `WAIT_TME` in SFC or in a sub-program called from SFC provokes a compile error.
 - Are not available when the code is compiled through a "C" compiler.
 - Using "C" code generation with a program containing a `WAIT` or `WAIT_TIME` instruction provokes an error during post-compiling.
- This statement is an extension to the standard and is NOT IEC 61131-3 compliant.

⚠ CAUTION

This instruction is NOT UDFB safe.
Do not use inside UDFBs.

FBD Language Example

Not available.

FFLD Language Example

Not available.

IL Language Example

Not available.

ST Language Example

```
(* use of WAIT with different kinds of BOOL expressions *)
WAIT BoolVariable;
WAIT (diLevel > 100) AND NOT bAlarm;
WAIT SubProgCall ();

(* use of WAIT_TIME with different kinds of TIME expressions *)
WAIT_TIME t#2s;
WAIT_TIME TimeVariable;
```

3.4.16 WHILE DO END_WHILE

Statement - Repeat a list of statements while a condition is TRUE.

3.4.16.1 Syntax

```
WHILE <BOOL expression> DO
    <statements>
END_WHILE;
```

Remarks

- The statements between **DO** and **END_WHILE** are executed while the Boolean expression is TRUE.
- The condition is evaluated **before** the statements are executed.
- If the condition is FALSE when **WHILE** is first reached, statements are never executed.

ⓘ IMPORTANT

Loop instructions can lead to infinite loops that block the target cycle.
Never test the state of an input in the condition because the input is not refreshed before the next cycle.

FBD Language Example

Not available.

FFLD Language Example

Not available.

IL Language Example

Not available.

ST Language Example

```
iMax := 10;
WHILE iPos < iMax DO
  MyArray[iPos]:=0;
  iPos +=1;
END_WHILE;
```

See Also

- "CASE OF ELSE END_CASE" (→ p. 100)
- "EXIT" (→ p. 101)
- "FOR TO BY END_FOR" (→ p. 102)
- "IF THEN ELSE ELSIF END_IF" (→ p. 103)
- "REPEAT UNTIL END_REPEAT" (→ p. 106)

3.5 Boolean Operations

PLCopen 

- "All Functions (Alphabetically)" (→ p. 111)
 - "Standard Operators" (→ p. 111)
 - "Available Blocks" (→ p. 112)

3.5.1 All Functions (Alphabetically)

Name	Description
AND ANDN &	Performs a logical AND of all inputs.
f_trig	Falling pulse detection.
FlipFlop	Flipflop bistable.
NOT	Performs a Boolean negation of the input.
OR / ORN	Performs a logical OR of all inputs.
QOR	Counts the number of TRUE inputs.
R	Force a Boolean output to FALSE.
r_trig	Rising pulse detection.
RS	Reset dominant bistable.
S	Force a Boolean output to TRUE.
sema	Semaphore.
SR	Set dominant bistable.
XOR / XORN	Performs an exclusive OR of all inputs.

3.5.1.1 Standard Operators

These are the operators for managing Booleans.

Name	Description
AND ANDN &	Performs a logical AND of all inputs.
NOT	Performs a Boolean negation of the input.
OR / ORN	Performs a logical OR of all inputs.
QOR	Counts the number of TRUE inputs.
R	Force a Boolean output to FALSE.
S	Force a Boolean output to TRUE.
XOR / XORN	Performs an exclusive OR of all inputs.

3.5.1.2 Available Blocks

These are the available blocks for managing Boolean signals:

Name	Description
f_trig	Falling pulse detection.
FlipFlop	Flipflop bistable.
r_trig	Rising pulse detection.
RS	Reset dominant bistable.
sema	Semaphore.
SR	Set dominant bistable.

3.5.2 FlipFlop

PLCopen 

 Function Block - Flipflop bistable.

Inputs

Input	Data Type	Range	Unit	Default	Description
IN	BOOL				Swap command (on rising edge).
RST	BOOL				Reset to FALSE.

Outputs

Output	Data Type	Range	Unit	Description
Q	BOOL			Output.

Remarks

- The output is systematically reset to FALSE if RST is TRUE.
- The output changes on each rising edge of the IN input, if RST is FALSE.

FBD Language Example

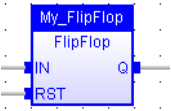

FPLD Language Example

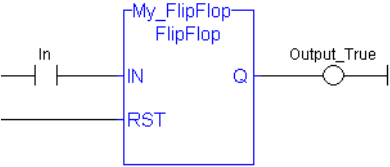

IL Language Example

```
(* MyFlipFlop is declared as an instance of FLIPFLOP function block: *)
Op1: CAL
MyFlipFlop (IN, RST)
    FFLD
MyFlipFlop.Q
    ST Q1
```

ST Language Example

```
(* MyFlipFlop is declared as an instance of FLIPFLOP function block: *)
MyFlipFlop (IN, RST);
Q := MyFlipFlop.Q;
```

See Also

- R
- S
- SR

3.5.3 f_trig



 **Function Block** - Falling pulse detection.

Inputs

Input	Data Type	Range	Unit	Default	Description
CLK	BOOL				Boolean signal.

Outputs

Output	Data Type	Range	Unit	Description
Q	BOOL			TRUE when the input changes from TRUE to FALSE.

Remarks

- It is recommended to use declared instances of R_TRIG or F_TRIG function blocks.
 - This is to avoid contingencies during an Online Change.

Truth Table

CLK	CCLK (prev)	Q
0	0	0
0	1	1
1	0	0
1	1	0

FBD Language Example



FFLD Language Example

- In the FFLD Language,]P[and]N[contacts can be used.



IL Language Example

```
(* MyTrigger is declared as an instance of F_TRIG function block *)
Op1: CAL MyTrigger (CLK)
LD MyTrigger.Q
ST Q
```

ST Language Example

```
(* MyTrigger is declared as an instance of F_TRIG function block. *)
MyTrigger (CLK);
Q := MyTrigger.Q;
```

See Also

r_trig

3.5.4 QOR

PLCopen 

Operator - Counts the number of TRUE inputs.

Inputs

Input	Data Type	Range	Unit	Default	Description
IN1 INn	BOOL				Boolean inputs.

Outputs

Output	Data Type	Range	Unit	Description
Q	DINT			Number of inputs being TRUE.

Remarks

- The block accepts a non-fixed number of inputs.

FBD Language Example

The block can have a maximum of 16 inputs.

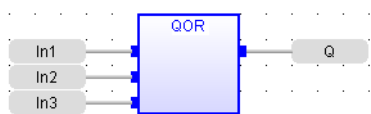

FFLD Language Example

The block can have a maximum of 16 inputs.

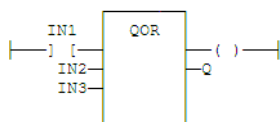

IL Language Example

```
Op1: LD  IN1
      QOR IN2, IN3
      ST  Q
```

ST Language Example

```
Q := QOR (IN1, IN2);
Q := QOR (IN1, IN2, IN3, IN4, IN5, IN6);
```

3.5.5 R

Operator - Force a Boolean output to FALSE.

Inputs

Input	Data Type	Range	Unit	Default	Description
RESET	BOOL				Condition.

Outputs

Output	Data Type	Range	Unit	Description
Q	BOOL			Output to be forced.

Remarks

None

Truth Table

RESET	Q (prev)	Q
0	0	0
0	1	1
1	0	0
1	1	0

FBD Language Example

- In the FBD Language, RS and SR function blocks are preferred.
 - Use "RS" (→ p. 117) or "SR" (→ p. 122) function blocks.
 - (S) and (R) coils can be used.

FFLD Language Example

- In the FFLD Language, they are represented by (S) and (R) coils.

Example: Use of R coil:

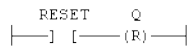

IL Language Example

- In the IL Language, S and R operators are available as standard instructions.

```

Op1: FFLD  RESET
      R    Q    (* Q is forced to FALSE if RESET is TRUE *)
              (* Q is unchanged if RESET is FALSE *)
    
```

ST Language Example

Not available.

See Also

- "RS" (→ p. 117)
- "S" (→ p. 119)
- "SR" (→ p. 122)

3.5.6 RS



 **Function Block** - Reset dominant bistable.

Inputs

Input	Data Type	Range	Unit	Default	Description
SET	BOOL				Condition for forcing to TRUE.
RESET1	BOOL				Condition for forcing to FALSE. Highest priority command.

Outputs

Output	Data Type	Range	Unit	Description
Q	BOOL			Output to be forced.

Remarks

- The output is unchanged when both inputs are FALSE.
- When both inputs are TRUE, the output is forced to FALSE. (reset dominant)

Truth Table

SET	RESET1	Q1 prev	Q1
0	0	0	0
0	0	1	1
0	1	0	0
0	1	1	0
1	0	0	1
1	0	1	1
1	1	0	0
1	1	1	0

FBD Language Example

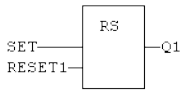

FFLD Language Example

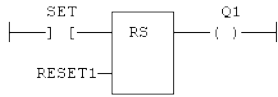

IL Language Example

```
(* MyRS is declared as an instance of RS function block *)
Op1: CAL MyRS (SET, RESET1)
      FFLD MyRS.Q1
      ST Q1
```

ST Language Example

```
(* MyRS is declared as an instance of RS function block *)
MyRS (SET, RESET1);
Q1 := MyRS.Q1;
```

See Also

- "R" (→ p. 116)
- "RS" (→ p. 117)
- "SR" (→ p. 122)

3.5.7 r_trig

[PLCopen](#) 



Function Block - Rising pulse detection.

Inputs

Input	Data Type	Range	Unit	Default	Description
CLK	BOOL				Boolean signal.

Outputs

Output	Data Type	Range	Unit	Description
Q	BOOL			TRUE when the input changes from FALSE to TRUE.

Remarks

- It is recommended to use declared instances of R_TRIG or F_TRIG function blocks.
 - This is to avoid contingencies during an Online Change.

Truth Table

CLK	CCLK (prev)	Q
0	0	0
0	1	0
1	0	1
1	1	0

FBD Language Example

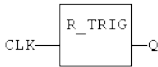

FFLD Language Example

- In the FFLD Language,]P[and]N[contacts can be used.
- The input signal is the rung.
- The rung is the output.

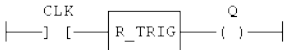

IL Language Example

```
(* MyTrigger is declared as an instance of R_TRIG function block *)
Op1: CAL MyTrigger (CLK)
FFLD MyTrigger.Q
ST Q
```

ST Language Example

```
(* MyTrigger is declared as an instance of R_TRIG function block *)
MyTrigger (CLK);
Q := MyTrigger.Q;
```

See Also

- "f_trig" (→ p. 113)

3.5.8 S

Operator - Force a Boolean output to TRUE.

Inputs

Input	Data Type	Range	Unit	Default	Description
SET	BOOL				Condition.

Outputs

Output	Data Type	Range	Unit	Description
Q	BOOL			Output to be forced.

Remarks

None

Truth Table

SET	Q prev	Q
0	0	0
0	1	1
1	0	1
1	1	1

FBD Language Example

- In the FBD Language, RS and SR function blocks are preferred.
 - Use "RS" (→ p. 117) or "SR" (→ p. 122) function blocks.
 - (S) and (R) coils can be used.

FFLD Language Example

- In the FFLD Language, they are represented by (S) and (R) coils.

Example: Use of S coil:

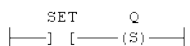

IL Language Example

- In the IL Language, S and R operators are available as standard instructions.

```

Op1: FFLD SET
      S Q (* Q is forced to TRUE if SET is TRUE *)
      (* Q is unchanged if SET is FALSE *)
  
```

ST Language Example

Not available.

See Also

- "R" (→ p. 116)
- "RS" (→ p. 117)
- "SR" (→ p. 122)

3.5.9 sema



Function Block - Semaphore.

Inputs

Input	Data Type	Range	Unit	Default	Description
CLAIM	BOOL				Takes the semaphore.
RELEASE	BOOL				Releases the semaphore.

Outputs

Output	Data Type	Range	Unit	Description
BUSY	BOOL			TRUE if semaphore is busy.

Remarks

The function block implements this algorithm:

```

BUSY := mem;
if CLAIM then
  mem := TRUE;
else if RELEASE then
  BUSY := FALSE;
  mem := FALSE;
end_if;

```

FBD Language Example

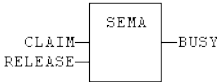

FFLD Language Example

- In the FFLD Language, the input rung is the CLAIM command.
 - The output rung is the BUSY output signal.

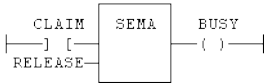

IL Language Example

```
(* MySema is a declared instance of SEMA function block *)
Op1: CAL MySema (CLAIM, RELEASE)
      FFLD MyBlinker.BUSY
      ST  BUSY
```

ST Language Example

```
(* MySema is a declared instance of SEMA function block *)
MySema (CLAIM, RELEASE);
BUSY := MyBlinker.BUSY;
```

3.5.10 SR

PLCopen 



Function Block - Set dominant bistable.

Inputs

Input	Data Type	Range	Unit	Default	Description
SET1	BOOL				Condition for forcing to TRUE. Highest priority command.
RESET	BOOL				Condition for forcing to FALSE.

Outputs

Output	Data Type	Range	Unit	Description
Q	BOOL			Output to be forced.

Remarks

- The output is unchanged when both inputs are FALSE.
- When both inputs are TRUE, the output is forced to FALSE. (set dominant)

Truth Table

SET1	RESET	Q1	Q1 prev
0	0	0	0
0	0	1	1
0	1	0	0
0	1	1	0
1	0	0	1
1	0	1	1

SET1	RESET	Q1 prev	Q1
1	1	0	1
1	1	1	1

FBD Language Example

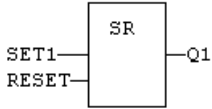

FFLD Language Example

- The SET1 command is the rung.
- The rung is the output.

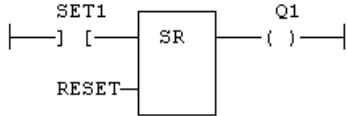

IL Language Example

```
(* MySR is declared as an instance of SR function block *)
Op1: CAL MySR (SET1, RESET)
      FFLD MySR.Q1
      ST Q1
```

ST Language Example

```
(* MySR is declared as an instance of SR function block *)
MySR (SET1, RESET);
Q1 := MySR.Q1;
```

See Also

- "R" (→ p. 116)
- "RS" (→ p. 117)
- "S" (→ p. 119)

3.5.11 XOR / XORN



Operator - Performs an exclusive OR of all inputs.

Inputs

Input	Data Type	Range	Unit	Default	Description
IN1	BOOL				First Boolean input.
IN2	BOOL				Second Boolean input.

Outputs

Output	Data Type	Range	Unit	Description
Q	BOOL			Exclusive OR of all inputs.

Remarks

- The block is called =1 in FBD and FFLD languages.

Truth Table

IN1	IN2	Q
0	0	0
0	1	1
1	0	1
1	1	0

FBD Language Example

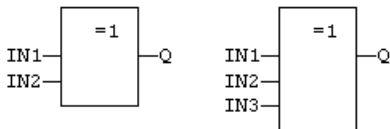

FFLD Language Example

- The first input is the rung.
- The rung is the output.

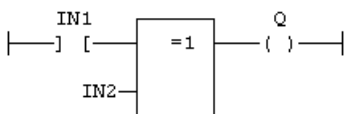

IL Language Example

- In the IL language, the XOR instruction performs an exclusive OR between the current result and the operand.
 - The current result must be Boolean.
 - The XORN instruction performs an exclusive between the current result and the Boolean negation of the operand.

```
Op1: FFLD  IN1
      XOR  IN2
```

```

    ST   Q   (* Q is equal to: IN1 XOR IN2 *)
Op2: FFLD   IN1
    XORN IN2
    ST   Q   (* Q is equal to: IN1 XOR (NOT IN2) *)

```

ST Language Example

```

Q := IN1 XOR IN2;
Q := IN1 XOR IN2 XOR IN3;

```

See Also

- AND ANDN &
- "NOT" (→ p. 248)
- OR / ORN

3.6 Clock Management Functions (Real Time)

- "All Functions (Alphabetically)" (→ p. 125)
 - "Format the Present Date / Time" (→ p. 126)
 - "Read the Real Time Clock" (→ p. 126)
 - "Time Zone and Clock Synchronization" (→ p. 126)
 - "Triggering Operations" (→ p. 127)

3.6.1 All Functions (Alphabetically)

Name	Description
day_time	Format the present date / time to a string.
DTAt	Generate a pulse at designated time stamp (date and time).
DTCurDate	Get the present date stamp.
DTCurDateTime	Get the present date and time stamp.
DTCurTime	Get the present time stamp.
DTDay	Get the day of the month from the date stamp.
DTEvery	Generate a pulse signal with long period.
DTFormat	Format the present date/time to a string with a custom format.
DTGetNTPServer	Read the NTP server address.
DTGetNTPSync	Read the NTP synchronization enable state.
DTGetTimeZone	Read the Time Zone.
DTHour	Get the hours from the time stamp.
DTListTimeZones	List the time zones available on the controller.
DTMake	Builds the date and time stamps according to DT conventions.
DTMin	Get the minutes from the time stamp.
DTMonth	Get the month from the date stamp.

Name	Description
DTMs	Get the milliseconds from the time stamp.
DTSec	Get the seconds from the time stamp.
DTSetDateTime	Sets the local date and time.
DTSetNTPServer	Set the NTP server address.
DTSetNTPSync	Set the NTP synchronization enable state.
DTSetTimeZone	Set the time zone.
DTYear	Get the year from the date stamp.

ⓘ IMPORTANT

- A real-time clock may not be available on all controller hardware models. See the controller hardware specifications for real-time clock availability.
- The AKD PDMM and PCMM reset the date and time when powered-on. The reset is to Jan 1, 1970 00:00:00. The elapsed time from device power-on can be determined from the Real Time Clock functions.
- PCMM2G does **not** reset the date and time when powered on.

3.6.1.1 Format the Present Date / Time

These functions format the present date/time to a string:

Name	Description
day_time	Format the present date / time to a string.
DTFormat	Format the present date/time to a string with a custom format.

3.6.1.2 Read the Real Time Clock

These functions read the real time clock of the target system:

Name	Description
DTCurDate	Get the present date stamp.
DTCurDateTime	Get the present date and time stamp.
DTCurTime	Get the present time stamp.
DTDay	Get the day of the month from the date stamp.
DTHour	Get the hours from the time stamp.
DTMake	Builds the date and time stamps according to DT conventions.
DTMin	Get the minutes from the time stamp.
DTMonth	Get the month from the date stamp.
DTMs	Get the milliseconds from the time stamp.
DTSec	Get the seconds from the time stamp.
DTYear	Get the year from the date stamp.

3.6.1.3 Time Zone and Clock Synchronization

These function blocks configure the time zone and clock synchronization for the controller.

Name	Description
DTGetNTPServer	Read the NTP server address.
DTGetNTPSync	Read the NTP synchronization enable state.
DTGetTimeZone	Read the Time Zone.
DTListTimeZones	List the time zones available on the controller.
DTSetDateTime	Sets the local date and time.
DTSetNTPServer	Set the NTP server address.
DTSetNTPSync	Set the NTP synchronization enable state.
DTSetTimeZone	Set the time zone.

3.6.1.4 Triggering Operations

These functions are used for triggering operations:

Name	Description
DTAt	Generate a pulse at designated time stamp (date and time).
DTEvery	Generate a pulse signal with long period.

3.6.2 day_time

 **Function** - Format the present date / time to a string.

Inputs

Input	Data Type	Range	Unit	Default	Description
SEL	DINT	0 to 2	N/A	No default	Format string.

Outputs

Output	Data Type	Range	Unit	Description
Q	STRING	No range	N/A	String containing formatted date or time.

Remarks

IMPORTANT

PCMM generation 1 controllers **do not** have real-time clock hardware.
 PCMM2G does have re-time clock hardware.
 Real-time clock may not be available on all controller hardware models.
 See the controller hardware specifications for real-time clock availability.

Valid values of the SEL input are:

Value	Description
0 (default)	Current date - format: YYYY/MM/DD.
1	Current time - format: HH:MM:SS.
2	Day of the week.

FBD Language Example



FFLD Language Example

- In the FFLD Language, the operation is executed only if the input rung (EN) is TRUE.
 - The output rung (ENO) keeps the same value as the input rung.

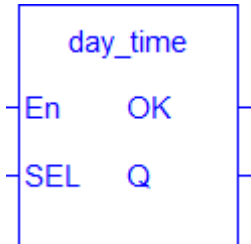

IL Language Example

```
Op1: LD SEL
      DAY_TIME
      ST Q
```

ST Language Example

```
Q := DAY_TIME (SEL);
```

See Also

DFormat

3.6.3 DTAt

 **Function Block** - Generate a pulse at designated time stamp (date and time).

3.6.3.1 Inputs

Input	Data Type	Range	Unit	Default	Description
Year	DINT	1900 to 2200	Years	No default	Year of the time stamp (e.g., 2006).
Month	DINT	1 to 12	Months	No default	Month of the time stamp (1 = January).
Day	DINT	1 to 31	Days	No default	Day of the time stamp .
TmOfDay	TIME	0 to 86,399,999	Milliseconds	No default	Time of day of the time stamp.
RST	BOOL	FALSE, TRUE	N/A	No default	Reset command.

3.6.3.2 Outputs

Output	Data Type	Range	Unit	Description
QAt	BOOL	FALSE, TRUE	N/A	Pulse signal.
QPast	BOOL	FALSE, TRUE	N/A	True if elapsed.

Remarks

ⓘ IMPORTANT

The real-time clock may not be available on all controller hardware models. See the controller hardware specifications for real-time clock availability.

- Parameters are not updated constantly. They are taken into account when only:
 - The first time the block is called.
 - When the reset input (RST) is TRUE.
- In these two situations, the outputs are reset to FALSE.
 - The first time the block is called with RST=FALSE and the specified date/stamp is passed:
 - The output QPAST is set to TRUE.
 - The output QAT is set to TRUE for one cycle only (pulse signal).
- Highest units are ignored if set to 0 (zero).
 - Example: If arguments are year=0, month=0, day = 3, tmoofday=t#10h, the block triggers on the next 3rd day of the month at 10h.

FBD Language Example

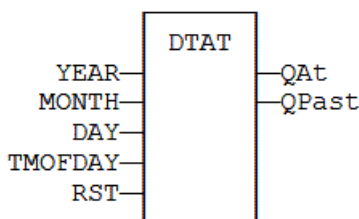

FFLD Language Example

- In the FFLD Language, the block is activated only if the input rung is TRUE.
- Called only if EN if TRUE.

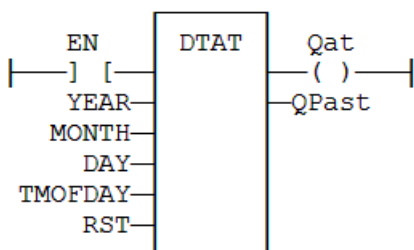

IL Language Example

```

(* MyDTAT is a declared instance of DTAT function block. *)
Op1: CAL
MyDTAT (YEAR, MONTH, DAY, TMOFDAY, RST)
FFLD MyDTAT.QAT
ST QAT
  
```

```
FFLD MyDTATA.QPAST
ST QPAST
```

ST Language Example

```
(* MyDTAT is a declared instance of DTAT function block. *)
MyDTAT (YEAR, MONTH, DAY, TMOFDAY, RST);
QAT := MyDTAT.QAT;
QPAST := MyDTATA.QPAST;
```

See Also

- DTEvery
- Clock Management Functions (Real Time)

3.6.4 DTCurDate



Function - Get the present date stamp.

Inputs

There are no Inputs for this function / function block.

Outputs

Output	Data Type	Range	Unit	Description
Q	DINT	No range	N/A	Numerical stamp representing the current date.

Remarks

None

FBD Language Example

Not available.

FFLD Language Example

Not available.

IL Language Example

Not available.

ST Language Example

```
Q := DTCurDate ();
```

See Also

- "DTDay" (→ p. 133)
- "DTMonth" (→ p. 148)
- "DTYear" (→ p. 159)

3.6.5 DTCurDateTime

Function Block - Get the present date and time stamp.

Inputs

Input	Data Type	Range	Unit	Default	Description
Local	BOOL	FALSE, TRUE	N/A	No default	<ul style="list-style-type: none"> • TRUE if local time is requested. • FALSE if GMT is requested.

Outputs

Output	Data Type	Range	Unit	Description
Year	DINT	1900 to 2200	Years	Present year.
Month	DINT	1 to 12	Months	Present month.
Day	DINT	1 to 31	Days	Present day.
Hour	DINT	0 to 23	Hours	Present time: hours.
Min	DINT	0 to 59	Minutes	Present time: minutes.
Sec	DINT	0 to 60	Seconds	Present time: seconds.
MSec	DINT	0 to 999	Milliseconds	Present time: milliseconds.
TmOfDay	TIME	0 to 86,399,999	Milliseconds	Present time of day (milliseconds since midnight).
DST	BOOL	FALSE, TRUE	N/A	Indicates if the time is in: <ul style="list-style-type: none"> • Daylight saving time (DST = TRUE) • Standard time (DST = FALSE)

Remarks

None

FBD Language Example

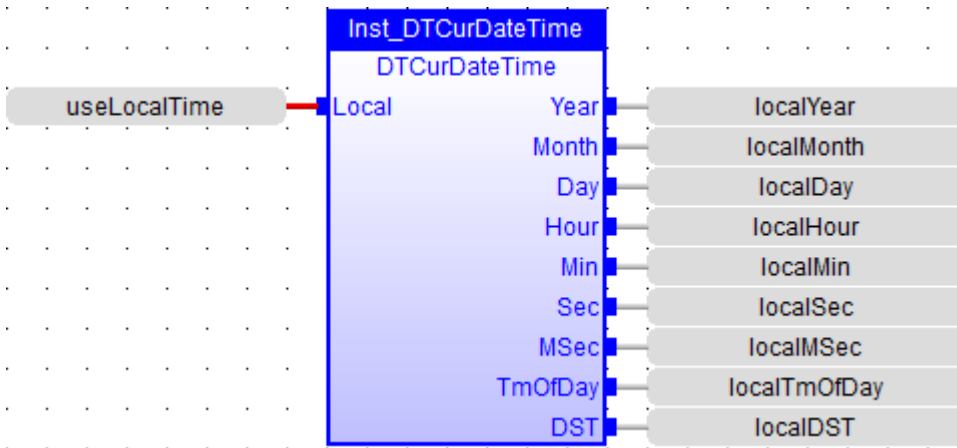

FFLD Language Example

Network #1

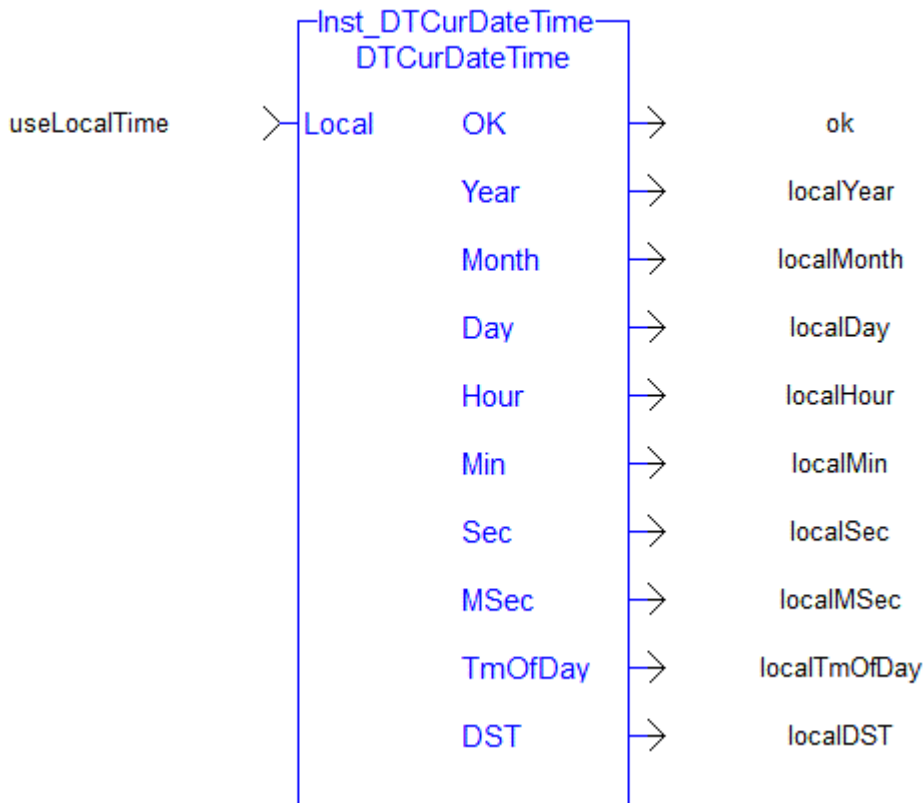

IL Language Example

Not available.

ST Language Example

```

Inst_DTCurDateTime (useLocalTime);
localYear      := Inst_DTCurDateTime.Year;
localMonth     := Inst_DTCurDateTime.Month;
    
```

```

localDay      := Inst_DTCurDateTime.Day;
localHour     := Inst_DTCurDateTime.Hour;
localMin      := Inst_DTCurDateTime.Min;
localSec      := Inst_DTCurDateTime.Sec;
localMSec     := Inst_DTCurDateTime.MSec;
localTmOfDay  := Inst_DTCurDateTime.TmOfDay;
localDST      := Inst_DTCurDateTime.DST;

```

3.6.6 DTCurTime



Function - Get the present time stamp.

Inputs

None

Outputs

Output	Data Type	Range	Unit	Description
Q	DINT	0 to 86,399,999	Milliseconds	Present milliseconds of the time.

Remarks

None

FBD Language Example

Not available.

FFLD Language Example

Not available.

IL Language Example

Not available.

ST Language Example

```
Q := DTCurTime ();
```

See Also

- "DTHour" (→ p. 143)
- "DTMin" (→ p. 147)
- "DTMs" (→ p. 149)
- "DTSec" (→ p. 150)

3.6.7 DTDay

 **Function** - Get the day of the month from the date stamp.

Inputs

Input	Data Type	Range	Unit	Default	Description
Date	DINT	No range	N/A	No default	Numerical stamp representing a date.

Outputs

Output	Data Type	Range	Unit	Description
Q	DINT	1 to 31	N/A	Day of the month of the date.

Remarks

None

FBD Language Example

Not available.

FFLD Language Example

Not available.

IL Language Example

Not available.

ST Language Example

```
Q := DTDAY (iDate);
```

See Also

- "DTCurDate" (→ p. 130)
- "DTMonth" (→ p. 148)
- "DTYear" (→ p. 159)

3.6.8 DTGetNTPServer

 **Function Block** - Read the NTP server address.

This function block is specific for PCMM2G only.

Inputs

Input	Data Type	Range	Unit	Default	Description
Execute	BOOL	FALSE, TRUE	N/A	No default	If TRUE, request to read the NTP server address.

Outputs

Output	Data Type	Range	Unit	Description
Done	BOOL	FALSE, TRUE	N/A	If TRUE, the command completed successfully.
Error	BOOL	FALSE, TRUE	N/A	If TRUE, an error has occurred.
ErrorID	DINT	No range	N/A	Indicates the error if the Error output is set to TRUE. Error Codes <ul style="list-style-type: none"> • 23 = Internal error. See the controller log for details. • 15000 = Controller type does not support this function block. • 16200 = Could not read NTP server configuration file.
NTP Server	STRING	No range	N/A	The address of the NTP server used for clock synchronization.

Remarks

None

FBD Language Example

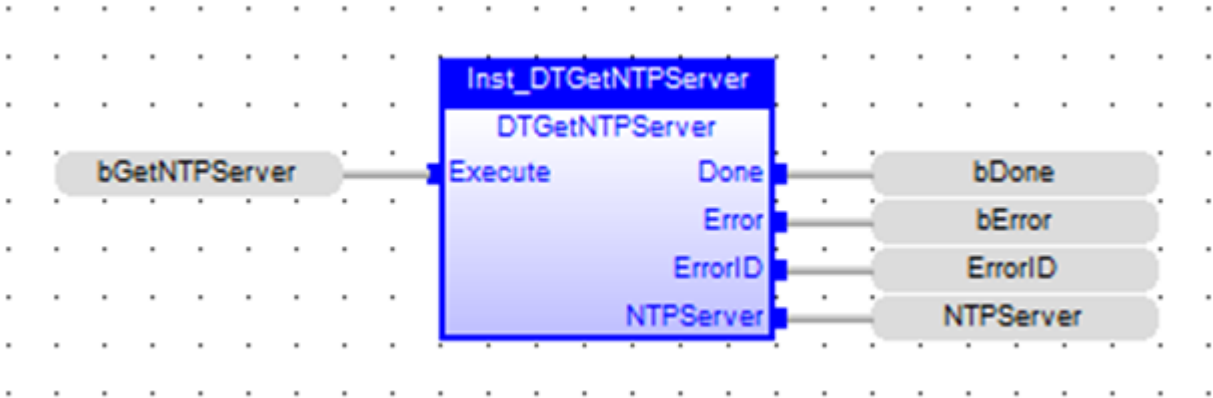

FFLD Language Example

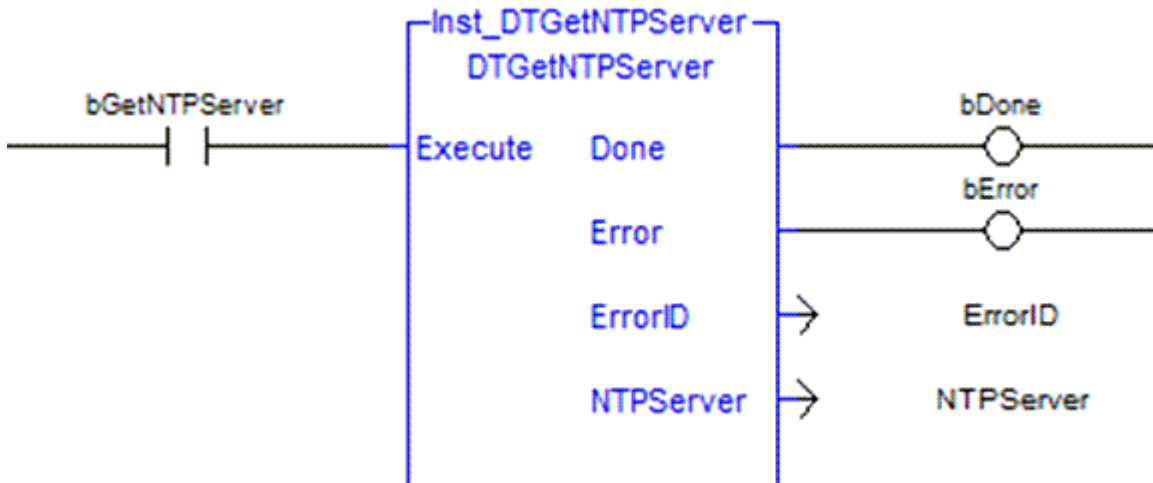

IL Language Example

Not available.

ST Language Example

```
// read the NTP server address
Inst_DTGetNTPServer( bGetNTPServer );
if Inst_DTGetNTPServer.Done then
  bGetNTPServer := false;
  if NOT Inst_DTGetNTPServer.Error then
    NTPServer := Inst_DTGetNTPServer.NTPServer;
  else
    ErrorID := Inst_DTGetNTPServer.ErrorID;
  end_if;
end_if;
```

See Also

- "DTCurDateTime" (→ p. 131)
- "DTGetNTPServer" (→ p. 134)
- "DTSetNTPServer" (→ p. 153)
- "DTSetNTPSync" (→ p. 155)
- "List of Date / Time / NTP ErrorID Codes" (→ p. 159)

3.6.9 DTGetNTPSync



Function Block - Read the NTP synchronization enable state.

This function block is specific for PCMM2G only.

Inputs

Input	Data Type	Range	Unit	Default	Description
Execute	BOOL	FALSE, TRUE	N/A	No default	If TRUE, request to read the synchronization enable state.

Outputs

Output	Data Type	Range	Unit	Description
Done	BOOL	FALSE, TRUE	N/A	If TRUE, the command completed successfully.
Error	BOOL	FALSE, TRUE	N/A	If TRUE, an error has occurred.
ErrorID	DINT	No range	N/A	Indicates the error if the Error output is set to TRUE. Error Codes <ul style="list-style-type: none"> • 23 = Internal error. See the controller log for details. • 15000 = Controller type does not support this function block.
SynchEn	BOOL	FALSE, TRUE	N/A	The present NTP synchronization state. <ul style="list-style-type: none"> • TRUE = synchronization enabled. • FALSE = synchronization disabled.

Remarks

None

FBD Language Example

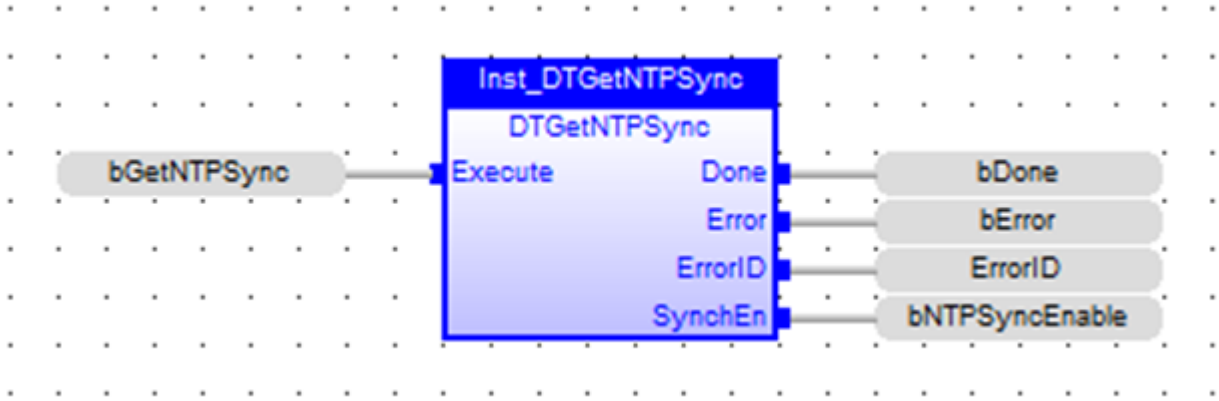

FFLD Language Example

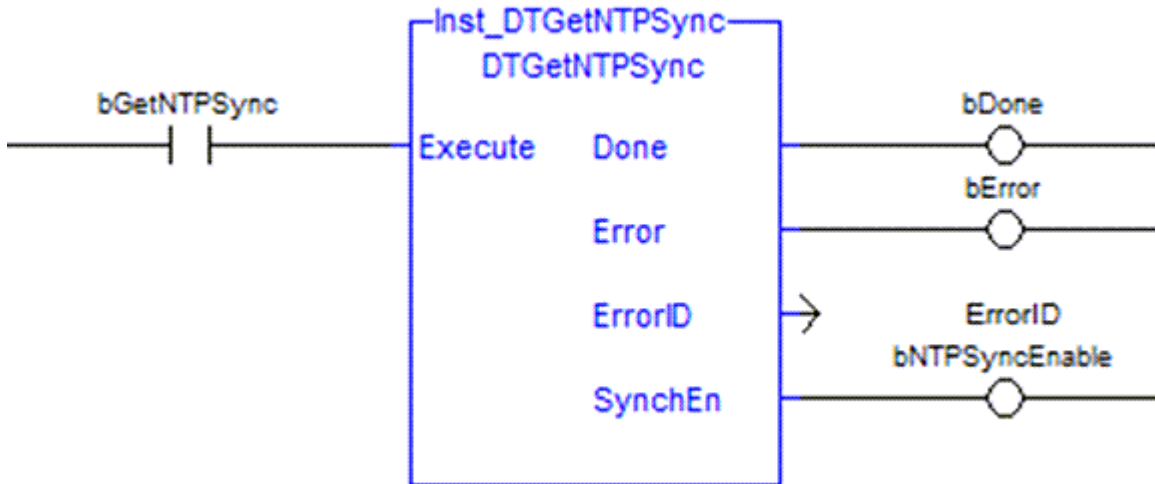

IL Language Example

Not available.

ST Language Example

```
// read the NTP synchronization state
Inst_DTGetNTPSync( bGetNTPSync );
if Inst_DTGetNTPSync.Done then
    bGetNTPSync := false;

    if NOT Inst_DTGetNTPSync.Error then
        bNTPSyncEnable := Inst_DTGetNTPSync.SynchEn;
    else
        ErrorID := Inst_DTGetNTPSync.ErrorID;
    end_if;
end_if;
```

See Also

- "DTCurDateTime" (→ p. 131)
- "DTSetNTPSync" (→ p. 155)
- "List of Date / Time / NTP ErrorID Codes" (→ p. 159)

3.6.10 DTGetTimeZone



Function Block - Read the Time Zone.

This function block is specific for PCMM2G only.

3.6.10.1 Inputs

Input	Data Type	Range	Unit	Default	Description
Execute	BOOL	FALSE, TRUE	N/A	No default	If TRUE, request to read the time zone.

3.6.10.2 Outputs

Output	Data Type	Range	Unit	Description
Done	BOOL	FALSE, TRUE	N/A	If TRUE, the command completed successfully.
Error	BOOL	FALSE, TRUE	N/A	If TRUE, an error has occurred.
ErrorID	DINT	No range	N/A	Indicates the error if the Error output is set to TRUE. Error Codes <ul style="list-style-type: none"> • 23 = Internal error. See the controller log for details. • 15000 = Controller type does not support this function block.
TimeZone	STRING	No range	N/A	The time zone the controller should use.

Remarks

None

FBD Language Example

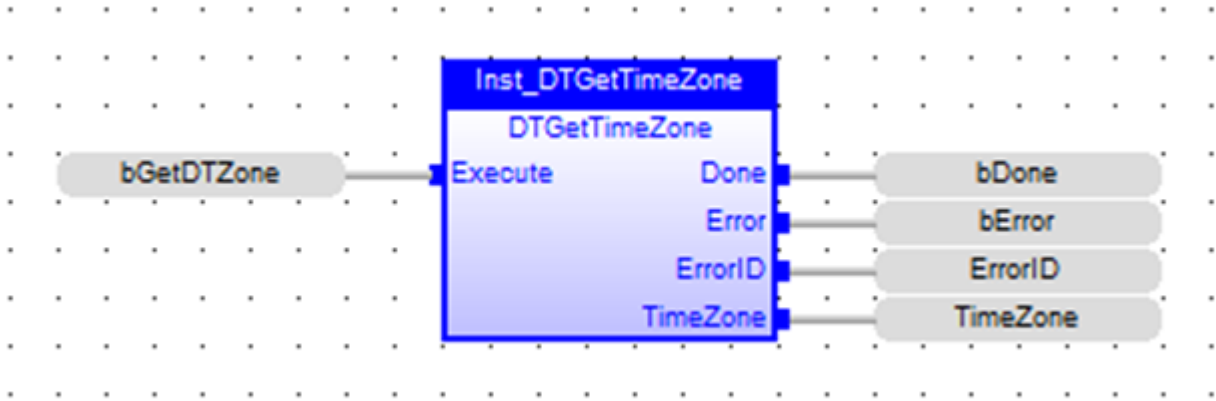

FFLD Language Example

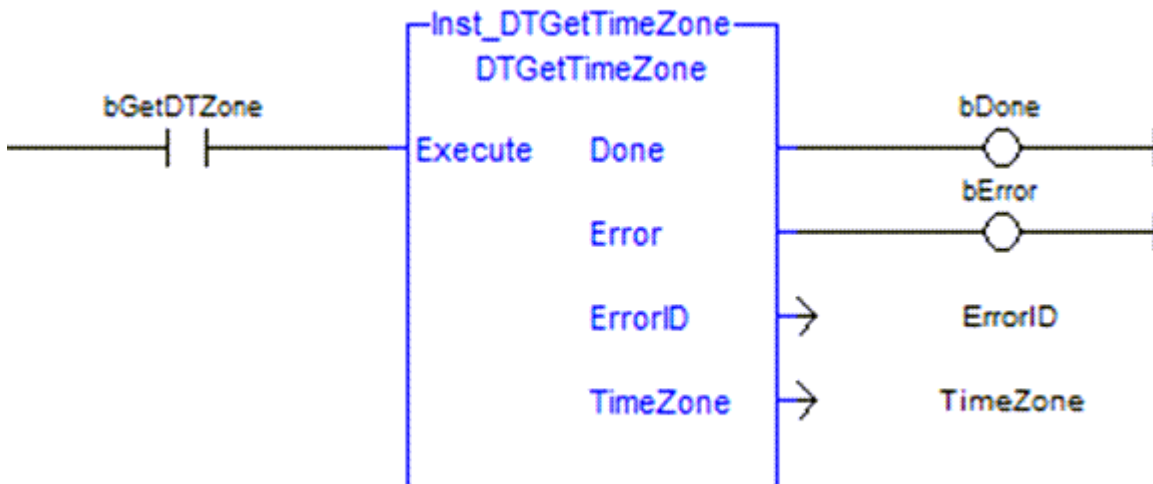

IL Language Example

Not available.

ST Language Example

```
// read the configured time zone
Inst_DTGetTimeZone( bGetDTZone );
if Inst_DTGetTimeZone.Done then
  bGetDTZone := false;

  if NOT Inst_DTGetTimeZone.Error then
    TimeZone := Inst_DTGetTimeZone.TimeZone;
  else
    ErrorID := Inst_DTGetTimeZone.ErrorID;
  end_if;
end_if;
```

See Also

- "DTCurDateTime" (→ p. 131)
- "DTSetTimeZone" (→ p. 157)
- "List of Date / Time / NTP ErrorID Codes" (→ p. 159)

3.6.11 DTEvery



Function Block - Generate a pulse signal with long period.

Inputs

Input	Data Type	Range	Unit	Default	Description
Run	BOOL	FALSE, TRUE	N/A	No default	When TRUE, the signal generation is enabled.
Days	DINT	1 to 65535	Days	No default	Period : number of days.
TM	Time	0 to 86,399,999	Milliseconds	No default	Rest of the period (if not a multiple of 24h).

Outputs

Output	Data Type	Range	Unit	Description
Q	BOOL	FALSE, TRUE	N/A	Pulse signal.

Remarks

- This function block provides a pulse signal with a period of more than 24h.
 - The period is expressed as:

$$\text{DAYS} * 24\text{h} + \text{TM}$$
- Example: Specifying DAYS=1 and TM=6h means a period of 30 hours.

FBD Language Example

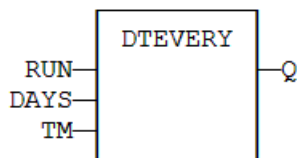

FFLD Language Example

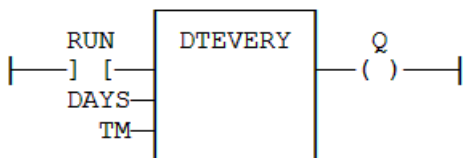

IL Language Example

Not available.

ST Language Example

```
(* MyDTEVERY is a declared instance of DTEVERY function block. *)
MyDTEVERY (RUN, DAYS, TM);
Q := MyDTEVERY.Q;
```

See Also

- DTAt
- Clock Management Functions (Real Time)

3.6.12 DTFormat

 **Function** - Format the present date/time to a string with a custom format.

Inputs

Input	Data Type	Range	Unit	Default	Description
FMT	STRING	No range	N/A	'%Y/%m/%d - %H:%M:%S'	Format string

Outputs

Output	Data Type	Range	Unit	Description
Q	STRING	No range	N/A	String containing formatted date or time.

Remarks

ⓘ IMPORTANT

The real-time clock may not be available on all controller hardware models. See the controller hardware specifications for real-time clock availability.

- The format string may contain any character.
- Special markers beginning with the % character indicates a date/time information:

Marker	Description
%Y	Year including century (e.g., 2006)
%y	Year without century (e.g., 06)
%m	Month (1..12)
%d	Day of the month (1..31)
%H	Hours (0..23)
%M	Minutes (0..59)
%S	Seconds (0..59)
%T	Milliseconds (0..999)

Example

```
(* we are at July 04th 2006, 18:45:20 *)
Q := DTFORMAT ('Today is %Y/%m/%d -%H:%M:%S');
(* Q is 'Today is 2006/07/04 - 18:45:20 *)
```

FBD Language Example

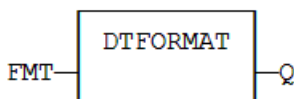

FFLD Language Example

- The function is executed only if EN is TRUE.
- ENO keeps the same value as EN.

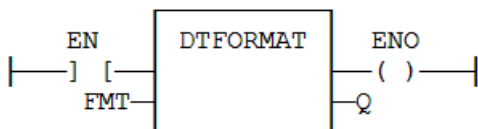

IL Language Example

```
Op1: LD FMT
DTFORMAT
ST Q
```

ST Language Example

```
Q := DTFORMAT (FMT);
```

See Also

day_time

3.6.13 DTHour



Function - Get the hours from the time stamp.

Inputs

Input	Data Type	Range	Unit	Default	Description
Time	DINT	0 to 86,399,999	Milliseconds	No default	The number of milliseconds that have passed since midnight. This value is typically retrieved from DTCurTime .

Outputs

Output	Data Type	Range	Unit	Description
Q	DINT	0 to 23	Hours	Hours of the time.

Remarks

None

FBD Language Example

Not available.

FFLD Language Example

Not available.

IL Language Example

Not available.

ST Language Example

```
Q := DTHour (iTime);
```

See Also

- "DTCurTime" (→ p. 133)
- "DTMin" (→ p. 147)
- "DTMs" (→ p. 149)
- "DTSec" (→ p. 150)

3.6.14 DTLISTTimeZones



Function Block - List the time zones available on the controller.

This function block is specific for PCMM2G only.

Inputs

Input	Data Type	Range	Unit	Default	Description
Execute	BOOL	FALSE, TRUE	N/A	No default	If TRUE, request to read the available time zones.
TimeZones	STRING []	No range	N/A	No default	An array where the list of time zones available on the system are copied. This is effectively an output parameter, but because it is an array, it must be an input.

Outputs

Output	Data Type	Range	Unit	Description
Done	BOOL	FALSE, TRUE	N/A	If TRUE, the command completed successfully.
Error	BOOL	FALSE, TRUE	N/A	If TRUE, an error has occurred.
ErrorID	DINT	No range	N/A	Indicates the error if Error output is TRUE. Error Codes <ul style="list-style-type: none"> • 23 = Internal error. See the controller log for details. • 15000 = Controller type does not support this function block.
TZCount	DINT	No range	N/A	The number of time zones on the system.

Remarks

None

FBD Language Example

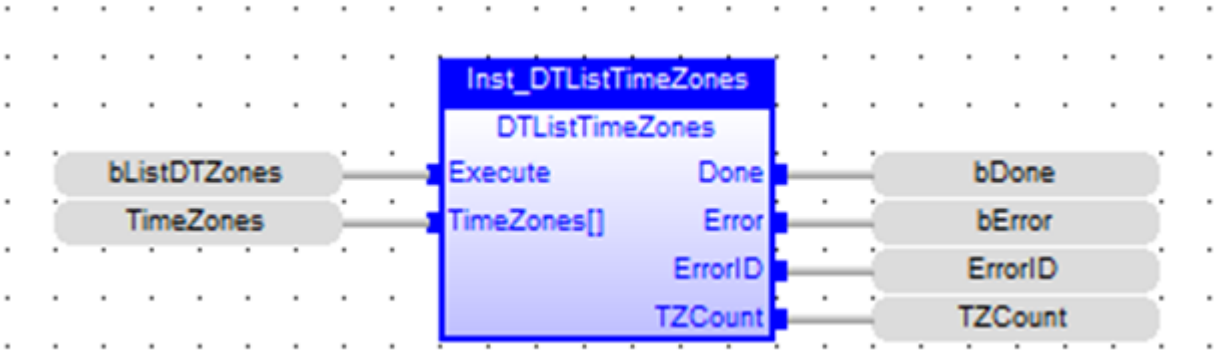

FFLD Language Example

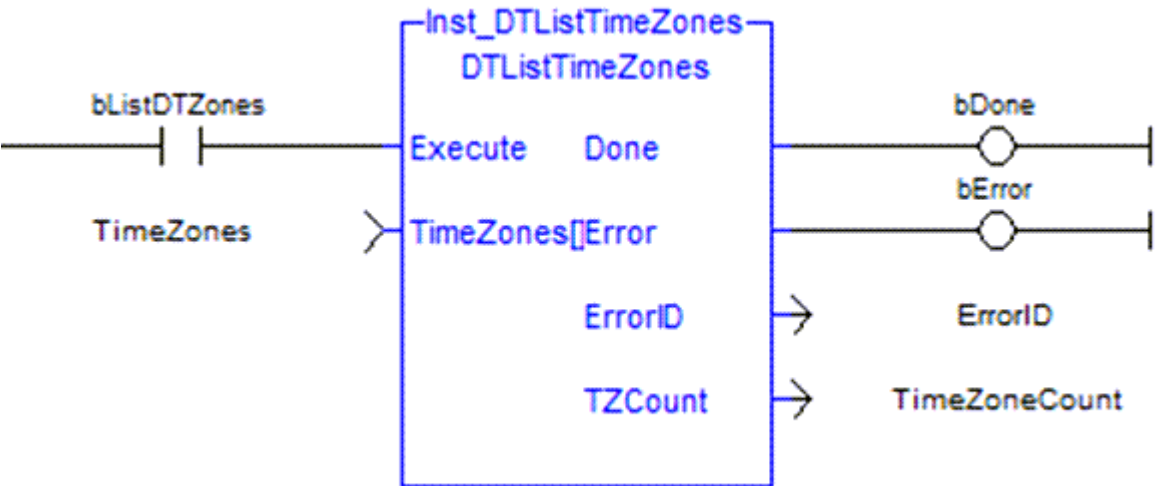

IL Language Example

Not available.

ST Language Example

```
// read the list of supported time zones
Inst_DTLISTTimeZones( bListDTZones, TimeZones );
if NOT Inst_DTLISTTimeZones.Error then
    TZCount := Inst_DTLISTTimeZones.TZCount;
else
    ErrorID := Inst_DTLISTTimeZones.ErrorID;
end_if;

if Inst_DTLISTTimeZones.Done then
    bListDTZones := false;
end_if;
```

See Also

- "DTGetTimeZone" (→ p. 138)
- "DTSetTimeZone" (→ p. 157)

3.6.15 DTMake

 **Function Block** - Builds the date and time stamps according to DT conventions.

The DT conventions are used in VSI functions to manage variable date and time stamps.

Inputs

Input	Data Type	Range	Unit	Default	Description
Year	DINT	1900 to 32767	Year	No default	Year specification. Example: 2024.
Month	DINT	1 to 12	Month	No default	Month in interval.
Day	DINT	1 to 31	Day	No default	Day of the month in interval.
Hour	DINT	0 to 23	Hour	No default	Hour of the day.
Minute	DINT	0 to 59	Minute	No default	Minute of the day.
Second	DINT	0 to 60	Second	No default	Second of the day.
MSec	DINT	0 to 999	N/A	No default	Milliseconds of the day.

Outputs

Output	Data Type	Range	Unit	Description
Ddate	DINT	No range	N/A	DT-like date stamp or 0 (zero) if some inputs are invalid.
Dtime	DINT	No range	N/A	DT-like date stamp or 0 (zero) if some inputs are invalid.

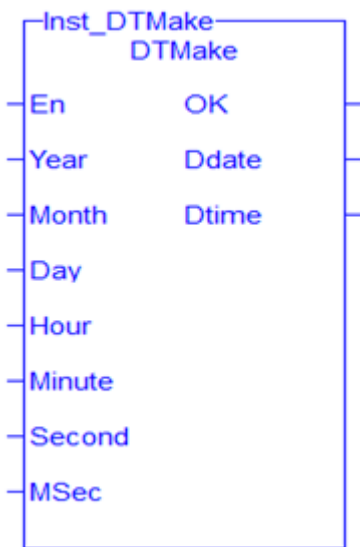

Figure 4-1: DTMake

Remarks

None

FBD Language Example

Not available.

FFLD Language Example

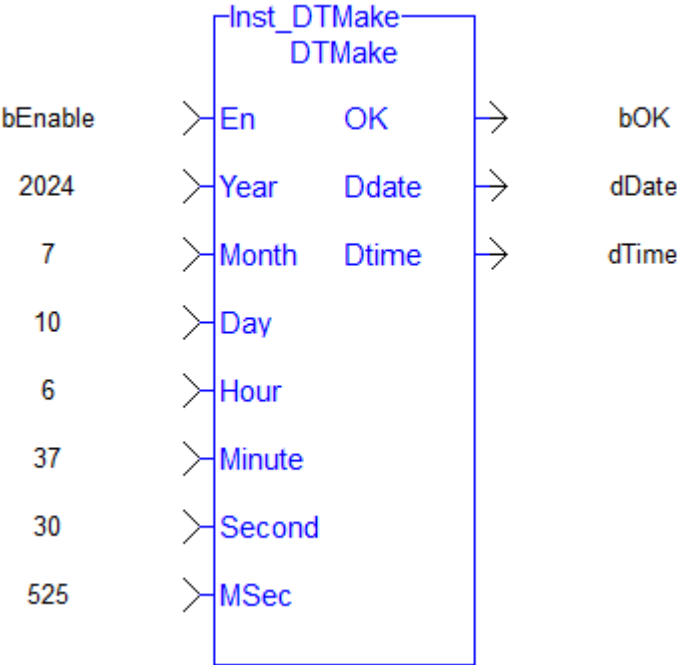

IL Language Example

Not available.

ST Language Example

```
Inst_DTMake1(2024, 7, 10, 6, 37, 30, 525);
dDate := Inst_DTMake1.Ddate;
dTime := Inst_DTMake1.Dtime;
```

3.6.16 DTMin

Function - Get the minutes from the time stamp.

Inputs

Input	Data Type	Range	Unit	Default	Description
Time	DINT	0 to 86,399,999	Milliseconds	No default	The number of milliseconds that have passed since midnight. This value is typically retrieved from DTCurTime .

Outputs

Output	Data Type	Range	Unit	Description
Q	DINT	0 to 59	Minutes	Minutes of the time.

Remarks

None

FBD Language Example

Not available.

FPLD Language Example

Not available.

IL Language Example

Not available.

ST Language Example

```
Q := DTMin (iTime);
```

See Also

- "DTCurTime" (→ p. 133)
- "DTHour" (→ p. 143)
- "DTMs" (→ p. 149)
- "DTSec" (→ p. 150)

3.6.17 DTMonth



Function - Get the month from the date stamp.

Inputs

Input	Data Type	Range	Unit	Default	Description
Date	DINT	No range	N/A	No default	Numerical stamp representing a date.

Outputs

Output	Data Type	Range	Unit	Description
Q	DINT	1 to 12	N/A	Month of the date.

Remarks

None

FBD Language Example

Not available.

FFLD Language Example

Not available.

IL Language Example

Not available.

ST Language Example

```
Q := DTMonth (iDate);
```

See Also

- "DTCurDate" (→ p. 130)
- "DTDay" (→ p. 133)
- "DTYear" (→ p. 159)

3.6.18 DTMs



Function - Get the milliseconds from the time stamp.

Inputs

Input	Data Type	Range	Unit	Default	Description
Time	DINT	0 to 86,399,999	Milliseconds	No default	The number of milliseconds that have passed since midnight. This value is typically retrieved from DTCurTime .

Outputs

Output	Data Type	Range	Unit	Description
Q	DINT	0 to 999	Milliseconds	Present milliseconds of the time.

Remarks

None

FBD Language Example

Not available.

FFLD Language Example

Not available.

IL Language Example

Not available.

ST Language Example

```
Q := DTMs (iTime);
```

See Also

- "DTCurTime" (→ p. 133)
- "DTHour" (→ p. 143)
- "DTMin" (→ p. 147)
- "DTSec" (→ p. 150)

3.6.19 DTSec



Function - Get the seconds from the time stamp.

Inputs

Input	Data Type	Range	Unit	Default	Description
Time	DINT	0 to 86,399,999	Milliseconds	No default	The number of milliseconds that have passed since midnight. This value is typically retrieved from DTCurTime .

Outputs

Output	Data Type	Range	Unit	Description
Q	DINT	0 to 59	Seconds	Seconds of the time.

Remarks

None

FBD Language Example

Not available.

FFLD Language Example

Not available.

IL Language Example

Not available.

ST Language Example

```
Q := DTSec (iTime);
```

See Also

- "DTCurTime" (→ p. 133)
- "DTHour" (→ p. 143)
- "DTMin" (→ p. 147)
- "DTMs" (→ p. 149)

3.6.20 DTSetDateTime



Function Block - Sets the local date and time.

This function block is specific for PCMM2G only.

Inputs

TIP

If the UTC time needs to be set, change the time zone to UTC using "DTSetTimeZone" (→ p. 157), set the time, then restore the time zone.

Input	Data Type	Range	Unit	Default	Description
Execute	BOOL	FALSE, TRUE	N/A	No default	If TRUE, request to set the local date and time.
Year	DINT	1900 to 2200	Year	No default	The local date's new value of the year.
Month	DINT	1 to 12	Month	No default	The local date's new value of the month.
Day	DINT	1 to 31	Day	No default	The local date's new value of the day.
Hour	DINT	0 to 23	Hour	No default	The local date's new value of the hour.
Minute	DINT	0 to 59	Minute	No default	The local date's new value of the minute.
Second	DINT	0 to 60	Second	No default	The local date's new value of the second.

NOTE

60 is valid because leap seconds may have a value of 60.

Outputs

Output	Data Type	Range	Unit	Description
Done	BOOL	FALSE, TRUE	N/A	If TRUE, the command completed successfully.
Error	BOOL	FALSE, TRUE	N/A	If TRUE, an error has occurred.

Output	Data Type	Range	Unit	Description
ErrorID	DINT	No range	N/A	<p>Indicates the error if the Error output is set to TRUE.</p> <p>Error Codes</p> <ul style="list-style-type: none"> • 23 = Internal error. See the controller log for details. • 15000 = Controller type does not support this function block. • 16202 = Cannot set date / time when NTP synchronization is active. • 16203 = Invalid date / time value specified.

Remarks

None

FBD Language Example

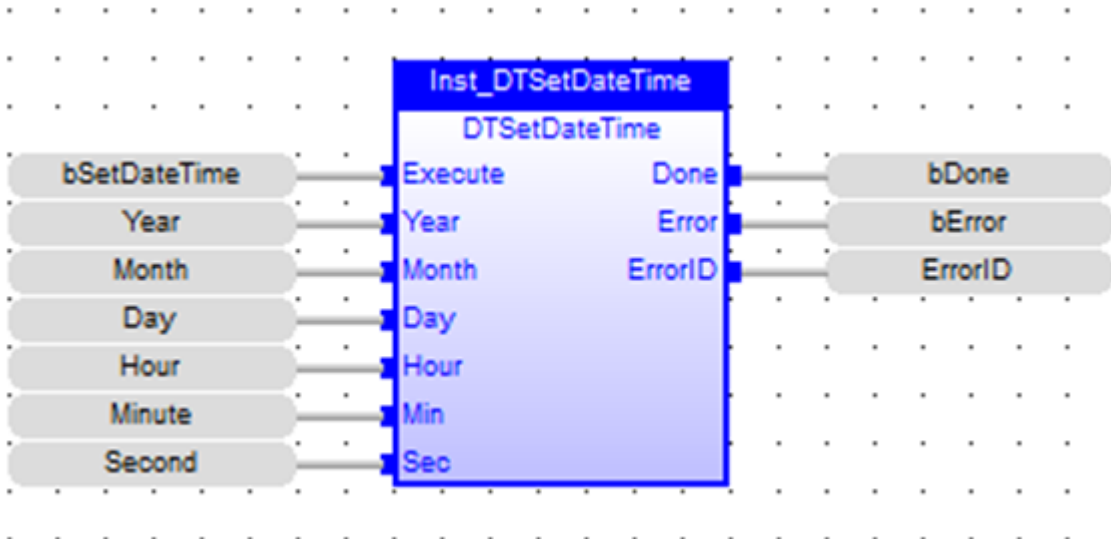

FFLD Language Example

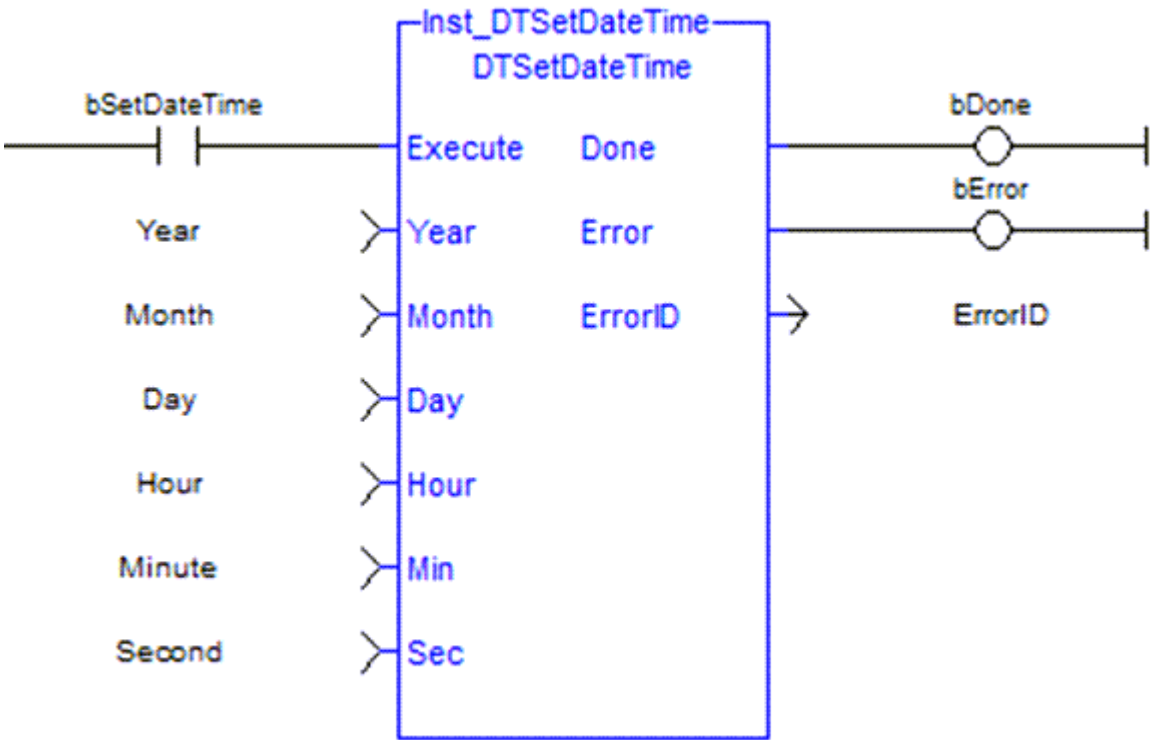

IL Language Example

Not available.

ST Language Example

```
// write the date and time
Inst_DTSetDateTime( bSetDateTime, Year, Month, Day, Hour, Minute, Second );
if Inst_DTSetDateTime.Done then
  bSetDateTime := false;

  bError := Inst_DTSetDateTime.Error;
  ErrorID := Inst_DTSetDateTime.ErrorID;
end_if;
```

See Also

- "DTCurDateTime" (→ p. 131)
- "DTSetTimeZone" (→ p. 157)
- "List of Date / Time / NTP ErrorID Codes" (→ p. 159)

3.6.21 DTSetNTPServer

 **Function Block** - Set the NTP server address.

This function block is specific for PCMM2G only.

Inputs

Input	Data Type	Range	Unit	Default	Description
Execute	BOOL	FALSE, TRUE	N/A	No default	If TRUE, request to set the NTP server address.
NTP Server	STRING	No range	N/A	No default	The address of the NTP server used for clock synchronization.

Outputs

Output	Data Type	Range	Unit	Description
Done	BOOL	FALSE, TRUE	N/A	If TRUE, the command completed successfully.
Error	BOOL	FALSE, TRUE	N/A	If TRUE, an error has occurred.
ErrorID	DINT	No range	N/A	Indicates the error if the Error output is set to TRUE.

Error Codes

- 23 = Internal error.
See the controller log for details.
- 15000 = Controller type does not support this function block.

Remarks

None

FBD Language Example

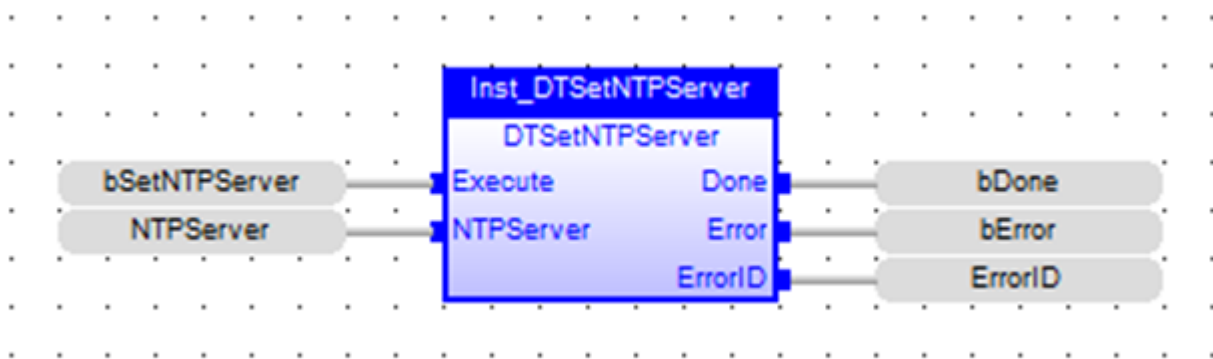

FFLD Language Example

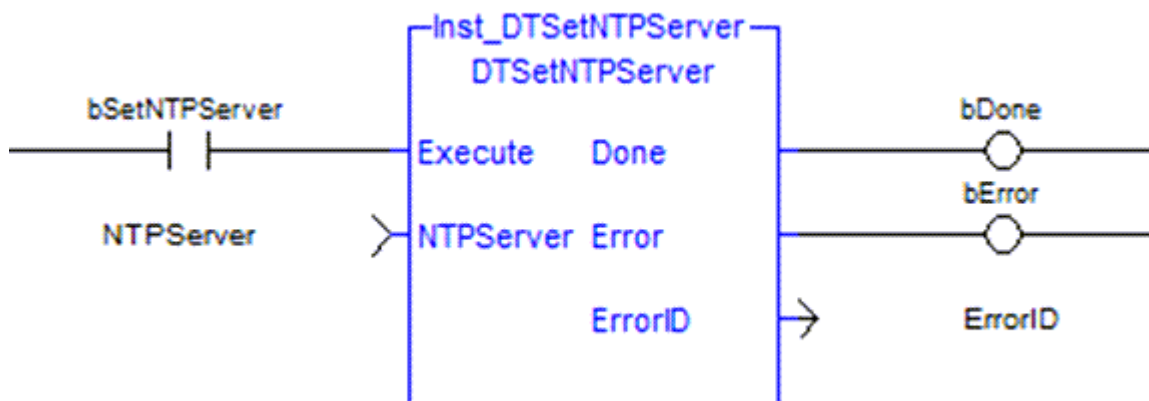

IL Language Example

Not available.

ST Language Example

```
// configure the NTP server address
Inst_DTSetNTPServer( bSetNTPServer, NTPServer );
if Inst_DTSetNTPServer.Done then
    bSetNTPServer := false;
    bError := Inst_DTSetNTPServer.Error;
    ErrorID := Inst_DTSetNTPServer.ErrorID;
end_if;
```

See Also

- "DTCurDateTime" (→ p. 131)
- "DTGetNTPServer" (→ p. 134)
- "DTGetNTPSync" (→ p. 136)
- "DTSetNTPSync" (→ p. 155)
- "List of Date / Time / NTP ErrorID Codes" (→ p. 159)

3.6.22 DTSetNTPSync



Function Block - Set the NTP synchronization enable state.

This function block is specific for PCMM2G only.

Inputs

Input	Data Type	Range	Unit	Default	Description
Execute	BOOL	FALSE, TRUE	N/A	No default	If TRUE, request to set the synchronization enable state.
SynchEn	BOOL	FALSE, TRUE	N/A	No default	<ul style="list-style-type: none"> • TRUE = enable NTP synchronization. • FALSE = disable NTP synchronization.

Outputs

Output	Data Type	Range	Unit	Description
Done	BOOL	FALSE, TRUE	N/A	If TRUE, the command completed successfully.
Error	BOOL	FALSE, TRUE	N/A	If TRUE, an error has occurred.
ErrorID	DINT	No range	N/A	Indicates the error if the Error output is set to TRUE. Error Codes <ul style="list-style-type: none"> • 23 = Internal error. See the controller log for details. • 15000 = Controller type does not support this function block.

Remarks

None

FBD Language Example

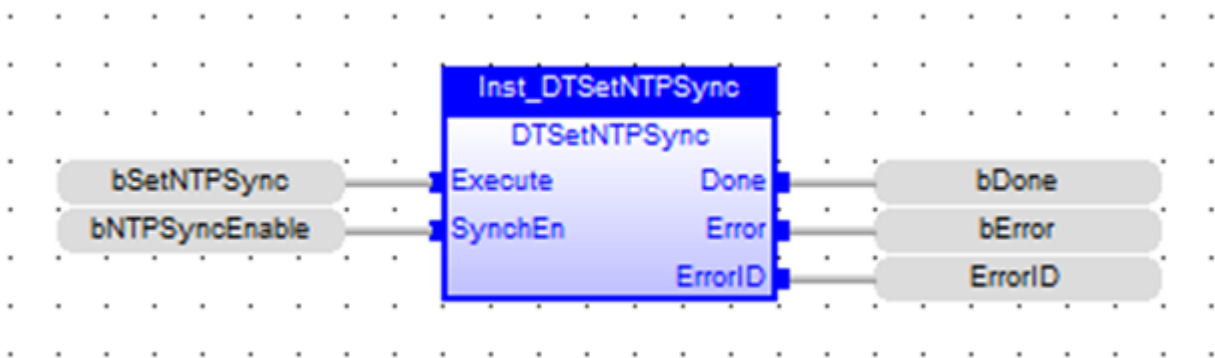

FFLD Language Example

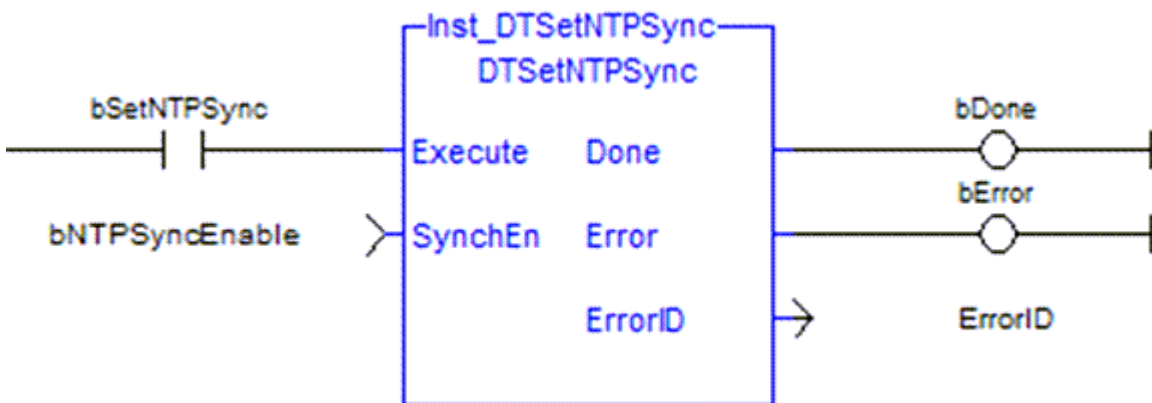

IL Language Example

Not available.

ST Language Example

```
// enable NTP server synchronization
Inst_DTSetNTPSync( bSetNTPSync, bNTPSyncEnable );
if Inst_DTSetNTPSync.Done then
    bSetNTPSync := false;

    bError := Inst_DTSetNTPSync.Error;
    ErrorID := Inst_DTSetNTPSync.ErrorID;
end_if;
```

See Also

- "DTCurDateTime" (→ p. 131)
- "DTGetNTPServer" (→ p. 134)
- "DTGetNTPSync" (→ p. 136)
- "DTSetNTPServer" (→ p. 153)
- "List of Date / Time / NTP ErrorID Codes" (→ p. 159)

3.6.23 DTSetTimeZone



Function Block - Set the time zone.

This function block is specific for PCMM2G only.

Inputs

Input	Data Type	Range	Unit	Default	Description
Execute	BOOL	FALSE, TRUE	N/A	No default	If TRUE, request to set the time zone.
TimeZone	STRING	No range	N/A	No default	The time zone the controller should use.

Outputs

Output	Data Type	Range	Unit	Description
Done	BOOL	FALSE, TRUE	N/A	If TRUE, the command completed successfully.
Error	BOOL	FALSE, TRUE	N/A	If TRUE, an error has occurred.
ErrorID	DINT	No range	N/A	Indicates the error if the Error output is set to TRUE. Error Codes <ul style="list-style-type: none"> • 23 = Internal error. See the controller log for details. • 15000 = Controller type does not support this function block. • 16201 = Invalid time zone.

Remarks

None

FBD Language Example



FFLD Language Example

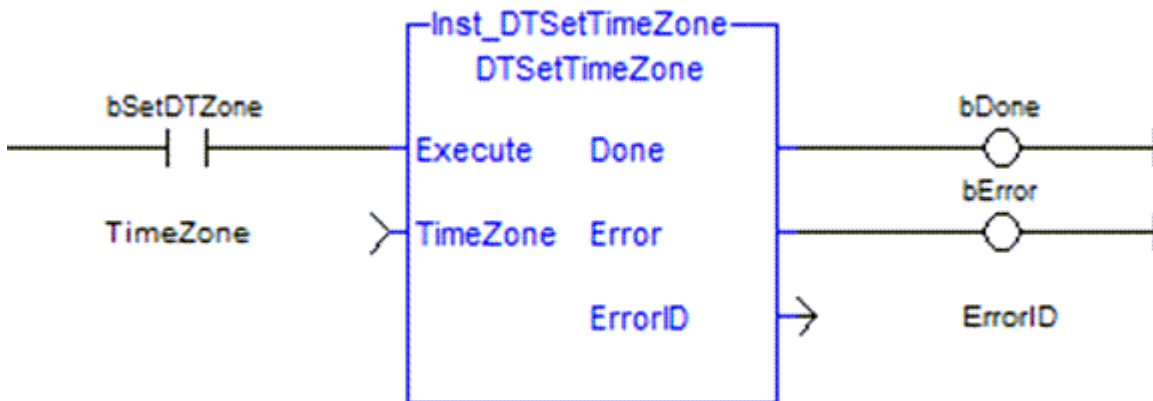

IL Language Example

Not available.

ST Language Example

```
// configure the time zone
Inst_DTSetTimeZone( bSetDTZone, TimeZone );
if Inst_DTSetTimeZone.Done then
    bSetDTZone := false;

    bError := Inst_DTSetTimeZone.Error;
    ErrorID := Inst_DTSetTimeZone.ErrorID;
end_if;
```

See Also

- "DTCurDateTime" (→ p. 131)
- "DTGetTimeZone" (→ p. 138)
- "DTListTimeZones" (→ p. 144)
- "List of Date / Time / NTP ErrorID Codes" (→ p. 159)

3.6.24 DTYear



Function - Get the year from the date stamp.

Inputs

Input	Data Type	Range	Unit	Default	Description
Date	DINT	No range	N/A	No default	Numerical stamp representing a date.

Outputs

Output	Data Type	Range	Unit	Description
Q	DINT	No range	N/A	Year of the date.

Remarks

None

FBD Language Example

Not available.

FFLD Language Example

Not available.

IL Language Example

Not available.

ST Language Example

```
Q := DTYear (iDate);
```

See Also

- "DTCurDate" (→ p. 130)
- "DTDay" (→ p. 133)
- "DTMonth" (→ p. 148)

3.6.25 List of Date / Time / NTP ErrorID Codes

- 23 = Internal error.
See the controller log for details.
- 15000 = Controller type does not support this function block.

- 16200 = Could not read NTP server configuration file.
- 16201 = Invalid time zone.
- 16202 = Cannot set date / time when NTP synchronization is active.
- 16203 = Invalid date / time value specified.

3.7 Comparison Operations



These are the standard operators and blocks that perform comparisons:

Operator	Description
CMP	Comparison with detailed outputs for integer inputs.
EQ =	Test if the first input is equal to the second input.
GE >=	Tests if the first input is greater than or equal to the second input.
GT >	Test if the first input is greater than the second input.
LE <=	Test if the first input is less than or equal to the second input.
LT <	Test if the first input is less than the second input.
NE <>	Test if the first input is not equal to the second input.

3.7.1 CMP



 **Function Block** - Comparison with detailed outputs for integer inputs.

Inputs

Input	Data Type	Range	Unit	Default	Description
IN1	DINT				First value.
IN2	DINT				Second value.

Outputs

Output	Data Type	Range	Unit	Description
EQ	BOOL			TRUE if IN1 = IN2.
GT	BOOL			TRUE if IN1 > IN2.
LT	BOOL			TRUE if IN1 < IN2.

Remarks

None

FBD Language Example

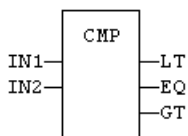

FFLD Language Example

- The rung input (EN) validates the operation.
 - The rung output is the result of **LT** (lower than) comparison).
 - The comparison is executed only if EN is TRUE.

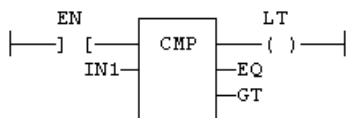

IL Language Example

```
(* MyCmp is declared as an instance of CMP function block *)
Op1: CAL MyCmp (IN1, IN2)
    LD MyCmp.LT
    ST bLT
    LD MyCmp.EQ
    ST bEQ
    LD MyCmp.GT
    ST bGT
```

ST Language Example

```
(* MyCmp is declared as an instance of CMP function block. *)
MyCMP (IN1, IN2);
bLT := MyCmp.LT;
bEQ := MyCmp.EQ;
bGT := MyCmp.GT;
```

See Also

- EQ =
- GE >=
- GT >
- LE <=
- LT <
- NE <>

3.7.2 GE >=



Operator - Tests if the first input is greater than or equal to the second input.

Inputs

Input	Data Type	Range	Unit	Default	Description
IN1	ANY_NUM				First input.
IN2	ANY_NUM				Second input.

Outputs

Output	Data Type	Range	Unit	Description
Q	BOOL			TRUE if IN1 >= IN2.

Remarks

- Both inputs must have the same type.
- Comparisons can be used with strings.
 - With strings, the lexical order is used for comparing the input strings.
 - Examples:
 - ABC is less than ZX.
 - ABCD is greater than ABC.

FBD Language Example

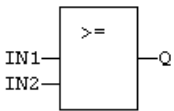

FFLD Language Example

- In the FFLD Language, the input rung (EN) enables the operation.
 - The output rung is the result of the comparison.
- The comparison is executed only if EN is TRUE.

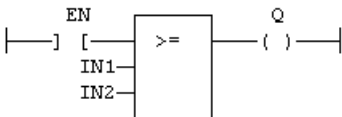

IL Language Example

- In the IL Language, the GE instruction performs the comparison between the current result and the operand.
 - The current result and the operand must have the same type.

```
Op1: FFLD IN1
      GE IN2
      ST Q    (* Q is true if IN1 >= IN2 *)
```

ST Language Example

```
Q := IN1 >= IN2;
```

See Also

- CMP
- EQ =
- GT >
- LE <=
- LT <
- NE <>

3.7.3 GT >



Operator - Test if the first input is greater than the second input.

Inputs

Input	Data Type	Range	Unit	Default	Description
IN1	ANY				First input.
IN2	ANY				Second input.

Outputs

Output	Data Type	Range	Unit	Description
Q	BOOL			TRUE if IN1 > IN2.

Remarks

- Both inputs must have the same type.
- Comparisons can be used with strings.
 - With strings, the lexical order is used for comparing the input strings.
 - Examples:
 - ABC is less than ZX.
 - ABCD is greater than ABC.

FBD Language Example

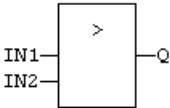

FFLD Language Example

- In the FFLD Language, the input rung (EN) enables the operation.
 - The output rung is the result of the comparison.
- The comparison is executed only if EN is TRUE.

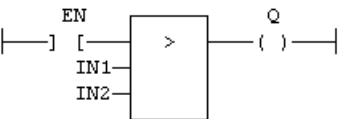

IL Language Example

- In the IL Language, the GT instruction performs the comparison between the current result and the operand.
 - The current result and the operand must have the same type.

```
Op1: FFLD  IN1
      GT  IN2
      ST  Q   (* Q is true if IN1 > IN2 *)
```

ST Language Example

```
Q := IN1 > IN2;
```

See Also

- CMP
- EQ =
- GE >=
- LE <=
- LT <
- NE <>

3.7.4 EQ =

[PLCopen](#) 

Operator - Test if the first input is equal to the second input.

Inputs

Input	Data Type	Range	Unit	Default	Description
IN1	ANY				First input.
IN2	ANY				Second input.

Outputs

Output	Data Type	Range	Unit	Description
Q	BOOL			TRUE if IN1 = IN2.

Remarks

- Both inputs must have the same type.
- Comparisons can be used with strings.
 - With strings, the lexical order is used for comparing the input strings.
 - Examples:
 - ABC is less than ZX.
 - ABCD is greater than ABC.

- Equality comparisons cannot be used with TIME variables.
 - This is because the timer actually has the resolution of the target cycle and test can be unsafe as some values can never be reached.

FBD Language Example

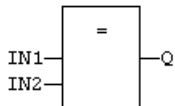

FFLD Language Example

- In the FFLD Language, the input rung (EN) enables the operation.
 - The output rung is the result of the comparison.
 - The comparison is executed only if EN is TRUE.

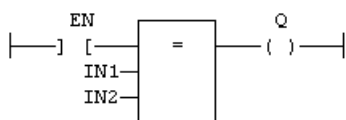

IL Language Example

- In the IL Language, the EQ instruction performs the comparison between the current result and the operand.
 - The current result and the operand must have the same type.

```
Op1: FFLD IN1
      EQ IN2
      ST Q    (* Q is true if IN1 = IN2 *)
```

ST Language Example

```
Q := IN1 = IN2;
```

See Also

- CMP
- GE >=
- GT >
- LE <=
- LT <
- NE <>

3.7.5 NE <>



Operator - Test if the first input is not equal to the second input.

Inputs

Input	Data Type	Range	Unit	Default	Description
IN1	ANY				First input.
IN2	ANY				Second input.

Outputs

Output	Data Type	Range	Unit	Description
Q	BOOL			TRUE if IN1 is not equal to IN2.

Remarks

- Both inputs must have the same type.
- Comparisons can be used with strings.
 - With strings, the lexical order is used for comparing the input strings.
 - Examples:
 - ABC is less than ZX.
 - ABCD is greater than ABC.
- Equality comparisons cannot be used with TIME variables.
 - This is because the timer actually has the resolution of the target cycle and test can be unsafe as some values can never be reached.

FBD Language Example

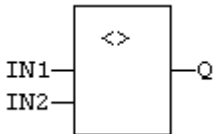

FFLD Language Example

- In the FFLD Language, the input rung (EN) enables the operation.
 - The output rung is the result of the comparison.
- The comparison is executed only if EN is TRUE.

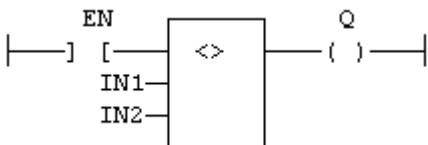

IL Language Example

- In the IL Language, the NE instruction performs the comparison between the current result and the operand.
 - The current result and the operand must have the same type.

```
Op1: FFLD IN1
      NE IN2
      ST Q    (* Q is true if IN1 is not equal to IN2 *)
```

ST Language Example

```
Q := IN1 <> IN2;
```

See Also

- CMP
- EQ =
- GE >=
- GT >
- LE <=
- LT <

3.7.6 LE <=

[PLCopen](#) 

Operator - Test if the first input is less than or equal to the second input.

Inputs

Input	Data Type	Range	Unit	Default	Description
IN1	ANY				First input.
IN2	ANY				Second input.

Outputs

Output	Data Type	Range	Unit	Description
Q	BOOL			TRUE if IN1 <= IN2.

Remarks

- Both inputs must have the same type.
- Comparisons can be used with strings.
 - With strings, the lexical order is used for comparing the input strings.
 - Examples:
 - ABC is less than ZX.
 - ABCD is greater than ABC.

FBD Language Example

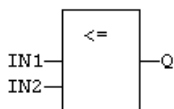

FFLD Language Example

- In the FFLD Language, the input rung (EN) enables the operation.
 - The output rung is the result of the comparison.
- The comparison is executed only if EN is TRUE.

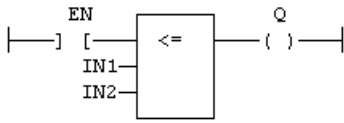

IL Language Example

- In the IL Language, the LE instruction performs the comparison between the current result and the operand.
- The current result and the operand must have the same type.

```
Op1: FFLD IN1
      LE IN2
      ST Q    (* Q is true if IN1 <= IN2 *)
```

ST Language Example

```
Q := IN1 <= IN2;
```

See Also

- CMP
- EQ =
- GE >=
- GT >
- LT <
- NE <>

3.7.7 LT <



Operator - Test if the first input is less than the second input.

Inputs

Input	Data Type	Range	Unit	Default	Description
IN1	ANY				First input.
IN2	ANY				Second input.

Outputs

Output	Data Type	Range	Unit	Description
Q	BOOL			TRUE if IN1 < IN2.

Remarks

- Both inputs must have the same type.
- Comparisons can be used with strings.
 - With strings, the lexical order is used for comparing the input strings.
 - Examples:
 - ABC is less than ZX.
 - ABCD is greater than ABC.

FBD Language Example

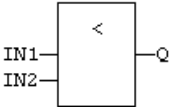

FFLD Language Example

- In the FFLD Language, the input rung (EN) enables the operation.
 - The output rung is the result of the comparison.
- The comparison is executed only if EN is TRUE.

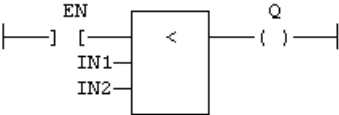

IL Language Example

- In the IL Language, the LT instruction performs the comparison between the current result and the operand.
 - The current result and the operand must have the same type.

```
Op1: FFLD IN1
      LT IN2
      ST Q      (* Q is true if IN1 < IN2 *)
```

ST Language Example

```
Q := IN1 < IN2;
```

See Also

- CMP
- EQ =
- GE >=
- GT >
- LE <=
- NE <>

3.8 Conversion Functions

- "All Functions (Alphabetically)" (→ p. 170)
 - "Convert Data to Another Data Type" (→ p. 170)
 - "BCD Format Conversions" (→ p. 170)

3.8.1 All Functions (Alphabetically)

Name	Description
any_to_bool	Converts the input into Boolean value.
any_to_dint / any_to_udint	Converts the input to a 32-bit integer value.
any_to_int / any_to_uint	Converts the input to a 16-bit integer value.
any_to_lint / any_to_ulint	Converts the input to a long, 64-bit integer value.
any_to_ireal	Converts the input into a double precision floating point real value.
any_to_real	Converts the input into a single precision floating point real value.
any_to_sint / any_to_usint	Converts the input into a short, 8-bit integer value.
any_to_string	Converts the input into a character string value.
any_to_time	Converts the input into a time value.
bcd_to_bin	Converts a Binary Coded Decimal (BCD) value to a binary value.
bin_to_bcd	Converts a binary value to a Binary Coded Decimal (BCD) value.
num_to_string	Converts a number into a string value.

3.8.1.1 Convert Data to Another Data Type

These are the standard functions for converting a data into another data type.

Name	Description
any_to_bool	Converts the input into Boolean value.
any_to_dint / any_to_udint	Converts the input to a 32-bit integer value.
any_to_int / any_to_uint	Converts the input to a 16-bit integer value.
any_to_lint / any_to_ulint	Converts the input to a long, 64-bit integer value.
any_to_ireal	Converts the input into a double precision floating point real value.
any_to_real	Converts the input into a single precision floating point real value.
any_to_sint / any_to_usint	Converts the input into a short, 8-bit integer value.
any_to_string	Converts the input into a character string value.
any_to_time	Converts the input into a time value.
num_to_string	Converts a number into a string value.

3.8.1.2 BCD Format Conversions

These are the standard functions performing conversions in BCD format.

BCD conversion functions may not be supported by all targets.

Name	Description
bcd_to_bin	Converts a Binary Coded Decimal (BCD) value to a binary value.

Name	Description
bin_to_bcd	Converts a binary value to a Binary Coded Decimal (BCD) value.

3.8.2 any_to_bool

PLCopen 

Operator - Converts the input into Boolean value.

Inputs

Input	Data Type	Range	Unit	Default	Description
IN	ANY				Input value.

Outputs

Output	Data Type	Range	Unit	Description
Q	BOOL			Converts the input into Boolean value.

Remarks

- For DINT, REAL, and TIME input data types, the result is FALSE if the input is 0 (zero).
 - The result is TRUE in all other cases.
- For STRING inputs, the output is TRUE if the input string is not empty.
 - The output is FALSE if the string is empty.

FBD Language Example

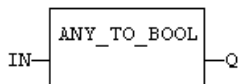

FFLD Language Example

- In the FFLD Language, the conversion is executed only if the input rung (EN) is TRUE.
 - The output rung is the result of the conversion.
 - The output rung is FALSE if the EN is FALSE.

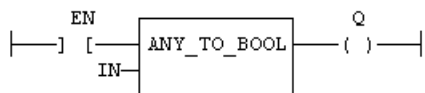

IL Language Example

- In the IL Language, the `any_to_bool` function converts the current result.

```
Op1: FFLD IN
      ANY_TO_BOOL
      ST Q
```

ST Language Example

```
Q := ANY_TO_BOOL (IN);
```

See Also

- any_to_dint / any_to_udint
- any_to_int / any_to_uint
- any_to_lint / any_to_ulint
- any_to_lreal
- any_to_real
- any_to_sint / any_to_usint
- any_to_string
- any_to_time

3.8.3 any_to_dint / any_to_udint

[PLCopen](#) 

Operator - Converts the input to a 32-bit integer value.

Inputs

Input	Data Type	Range	Unit	Default	Description
IN	ANY			32-bit	Input value.

Outputs

Output	Data Type	Range	Unit	Description
Q	DINT			Value converted to a signed double integer (32-bit).
Q	UDINT			Value converted to an unsigned double integer (32-bit).

Remarks

- The default is 32-bit.
- Can be unsigned with `any_to_udint`.

Data Type Outputs

- For BOOL input data types, the output is 0 (zero) or 1.
- For REAL input data type, the output is the integer part of the input real.
- For TIME input data types, the output is the number of milliseconds.
- For STRING input data types, the output is the number represented by the string or 0 (zero) if the string does not represent a valid number.

FBD Language Example

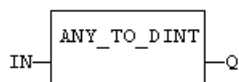

FFLD Language Example

- In the FFLD Language, the conversion is executed only if the input rung (EN) is TRUE.
 - The output rung (ENO) keeps the same value as the input rung.

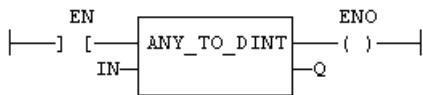

IL Language Example

- In the IL Language, the `any_to_udint` converts the current result.

```
Op1: FFLD IN
      ANY_TO_DINT
      ST Q
```

ST Language Example

```
Q := ANY_TO_DINT (IN);
```

See Also

- `any_to_bool`
- `any_to_int` / `any_to_uint`
- `any_to_lint` / `any_to_ulint`
- `any_to_lreal`
- `any_to_real`
- `any_to_sint` / `any_to_usint`
- `any_to_string`
- `any_to_time`

3.8.4 any_to_int / any_to_uint



Operator - Converts the input to a 16-bit integer value.

Inputs

Input	Data Type	Range	Unit	Default	Description
IN	ANY				Input value.

Outputs

Output	Data Type	Range	Unit	Description
Q	INT			Value converted to a signed integer. (16-bit).
Q	UINT			Value converted to an unsigned integer. (16-bit).

Remarks

Can be unsigned with `any_to_uint`.

Data Type Outputs

- For BOOL input data types, the output is 0 (zero) or 1.
- For REAL input data type, the output is the integer part of the input real.
- For TIME input data types, the output is the number of milliseconds.
- For STRING input data types, the output is the number represented by the string or 0 (zero) if the string does not represent a valid number.

FBD Language Example

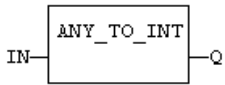

FFLD Language Example

- In the FFLD Language, the conversion is executed only if the input rung (EN) is TRUE.
 - The output rung (ENO) keeps the same value as the input rung.

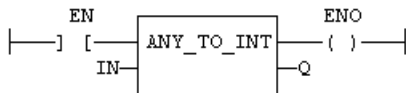

IL Language Example

- In the IL Language, the `any_to_int` converts the current result.

```
Op1: FFLD IN
      ANY_TO_INT
      ST Q
```

ST Language Example

```
Q := ANY_TO_INT (IN);
```

See Also

- `any_to_bool`
- `any_to_dint` / `any_to_udint`
- `any_to_lint` / `any_to_ulint`
- `any_to_lreal`
- `any_to_real`
- `any_to_sint` / `any_to_usint`
- `any_to_string`
- `any_to_time`

3.8.5 `any_to_lint` / `any_to_ulint`



Operator - Converts the input to a long, 64-bit integer value.

Inputs

Input	Data Type	Range	Unit	Default	Description
IN	ANY				Input value.

Outputs

Output	Data Type	Range	Unit	Description
Q	LINT			Value converted to long, 64-bit integer.
Q	ULINT			Value converted to long, 64-bit unsigned integer.

Remarks

Can be unsigned with `any_to_ulint`.

Data Type Outputs

- For BOOL input data types, the output is 0 (zero) or 1.
- For REAL input data type, the output is the integer part of the input real.
- For TIME input data types, the output is the number of milliseconds.
- For STRING input data types, the output is the number represented by the string or 0 (zero) if the string does not represent a valid number.

FBD Language Example

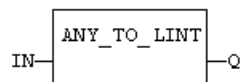

FFLD Language Example

- In the FFLD Language, the conversion is executed only if the input rung (EN) is TRUE.
 - The output rung (ENO) keeps the same value as the input rung.

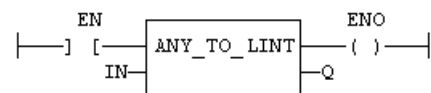

IL Language Example

- In the IL Language, the `any_to_lint` converts the current result.

```
Op1: FFLD IN
      ANY_TO_LINT
      ST Q
```

ST Language Example

```
Q := ANY_TO_LINT (IN);
```

See Also

- any_to_bool
- any_to_dint / any_to_udint
- any_to_int / any_to_uint
- any_to_lreal
- any_to_real
- any_to_sint / any_to_usint
- any_to_string
- any_to_time

3.8.6 any_to_lreal



Operator - Converts the input into a double precision floating point real value.

Inputs

Input	Data Type	Range	Unit	Default	Description
IN	ANY				Input value.

Outputs

Output	Data Type	Range	Unit	Description
Q	LREAL			Converts the input into a double precision floating point real value.

Remarks

None

Data Type Outputs

- For BOOL input data types, the output is 0.0 or 1.0.
- For DINT input data types, the output is the same number.
- For TIME input data types, the output is the number of milliseconds.
- For STRING input data types, the output is the number represented by the string or 0.0 if the string does not represent a valid number.

FBD Language Example

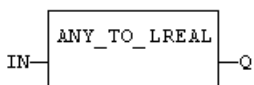

FFLD Language Example

- In the FFLD Language, the conversion is executed only if the input rung (EN) is TRUE.
 - The output rung (ENO) keeps the same value as the input rung.

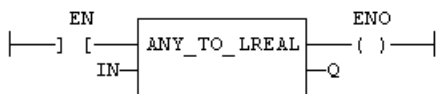

IL Language Example

- In the IL Language, the `any_to_lreal` converts the current result.

```
Op1: FFLD IN
      ANY_TO_LREAL
      ST Q
```

ST Language Example

```
Q := ANY_TO_LREAL (IN);
```

See Also

- `any_to_bool`
- `any_to_dint` / `any_to_udint`
- `any_to_int` / `any_to_uint`
- `any_to_lint` / `any_to_ulint`
- `any_to_real`
- `any_to_sint` / `any_to_usint`
- `any_to_string`
- `any_to_time`

3.8.7 any_to_real

[PLCopen](#)

Operator - Converts the input into a single precision floating point real value.

Inputs

Input	Data Type	Range	Unit	Default	Description
IN	ANY				Input value.

3.8.7.1 Outputs

Output	Data Type	Range	Unit	Description
Q	REAL			Converts the input into a single precision floating point real value.

Remarks

None

Data Type Outputs

- For BOOL input data types, the output is 0.0 or 1.0.
- For DINT input data types, the output is the same number.
- For TIME input data types, the output is the number of milliseconds.
- For STRING input data types, the output is the number represented by the string or 0.0 if the string does not represent a valid number.

FBD Language Example

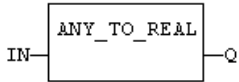

FFLD Language Example

- In the FFLD Language, the conversion is executed only if the input rung (EN) is TRUE.
 - The output rung (ENO) keeps the same value as the input rung.

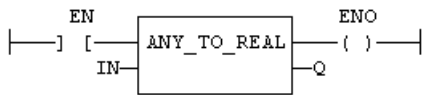

IL Language Example

- In the IL Language, the `any_to_real` converts the current result.

```
Op1: FFLD  IN
      ANY_TO_REAL
      ST  Q
```

ST Language Example

```
Q := ANY_TO_REAL (IN);
```

See Also

- `any_to_bool`
- `any_to_dint` / `any_to_udint`
- `any_to_int` / `any_to_uint`
- `any_to_lint` / `any_to_ulint`
- `any_to_lreal`
- `any_to_sint` / `any_to_usint`
- `any_to_string`
- `any_to_time`

3.8.8 any_to_time



Operator - Converts the input into a time value.

Inputs

Input	Data Type	Range	Unit	Default	Description
IN	ANY				Input value.

Outputs

Output	Data Type	Range	Unit	Description
Q	TIME			Converts the input into a time value.

Remarks

- For BOOL input data types, the output is t#0ms or t#1ms.
- For DINT or REAL input data type, the output is the time represented by the input number as a number of milliseconds.
- For STRING input data types, the output is the time represented by the string or t#0ms if the string does not represent a valid time.

FBD Language Example

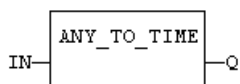

FFLD Language Example

- In the FFLD Language, the conversion is executed only if the input rung (EN) is TRUE.
 - The output rung (ENO) keeps the same value as the input rung.

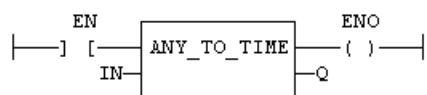

IL Language Example

- In the IL Language, the `any_to_time` converts the current result.

```
Op1: FFLD IN
ANY_TO_TIME
ST Q
```

ST Language Example

```
Q := ANY_TO_TIME (IN);
```

See Also

- `any_to_bool`
- `any_to_dint` / `any_to_udint`
- `any_to_int` / `any_to_uint`
- `any_to_lint` / `any_to_ulint`

- any_to_ireal
- any_to_real
- any_to_sint / any_to_usint
- any_to_string

3.8.9 any_to_sint / any_to_usint



Operator - Converts the input into a short, 8-bit integer value.

Inputs

Input	Data Type	Range	Unit	Default	Description
IN	ANY				Input value.

Outputs

Output	Data Type	Range	Unit	Description
Q	SINT			Value converted to a signed short integer. (8-bit).
Q	USINT			Value converted to an unsigned short integer. (8-bit).

Remarks

Can be unsigned with `any_to_usint`.

Data Type Outputs

- For BOOL input data types, the output is 0 (zero) or 1.
- For REAL input data type, the output is the integer part of the input real.
- For TIME input data types, the output is the number of milliseconds.
- For STRING input data types, the output is the number represented by the string or 0 (zero) if the string does not represent a valid number.

FBD Language Example

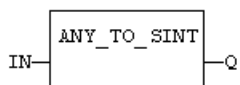

FFLD Language Example

- In the FFLD Language, the conversion is executed only if the input rung (EN) is TRUE.
 - The output rung (ENO) keeps the same value as the input rung.

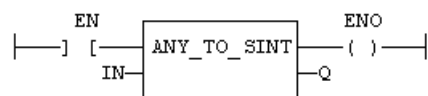

IL Language Example

- In the IL Language, the `any_to_sint` converts the current result.

```
Op1: FFLD  IN
      ANY_TO_SINT
      ST  Q
```

ST Language Example

```
Q := ANY_TO_SINT (IN);
```

See Also

- `any_to_bool`
- `any_to_dint` / `any_to_udint`
- `any_to_int` / `any_to_uint`
- `any_to_lint` / `any_to_ulint`
- `any_to_lreal`
- `any_to_real`
- `any_to_string`
- `any_to_time`

3.8.10 any_to_string



Operator - Converts the input into a character string value.

Inputs

Input	Data Type	Range	Unit	Default	Description
IN	ANY				Input value.

Outputs

Output	Data Type	Range	Unit	Description
Q	STRING			Converts the input into a character string value.

Remarks

- For BOOL input data types, the output is
 - 0 for FALSE.
 - 1 for TRUE.
- For DINT, REAL, or TIME input data types, the output is the string representation of the input number.
 - This is a number of milliseconds for TIME inputs.

FBD Language Example

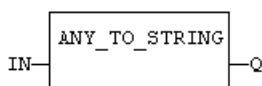

FFLD Language Example

- In the FFLD Language, the conversion is executed only if the input rung (EN) is TRUE.
 - The output rung (ENO) keeps the same value as the input rung.

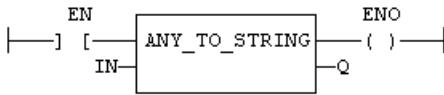

IL Language Example

- In the IL Language, the `any_to_string` function converts the current result.

```
Op1: FFLD IN
      ANY_TO_STRING
      ST Q
```

ST Language Example

```
Q := ANY_TO_STRING (IN);
```

See Also

- `any_to_bool`
- `any_to_dint` / `any_to_udint`
- `any_to_int` / `any_to_uint`
- `any_to_lint` / `any_to_ulint`
- `any_to_lreal`
- `any_to_real`
- `any_to_sint` / `any_to_usint`
- `any_to_time`

3.8.11 num_to_string

[PLCopen](#)



Function - Converts a number into a string value.

Inputs

Input	Data Type	Range	Unit	Default	Description
IN	ANY				Input number.
Width	DINT				Length of the output string.
Digits	DINT				Number of digits after decimal point.

Outputs

Output	Data Type	Range	Unit	Description
Q	STRING			Value converted to string.

Remarks

This function converts any numerical value to a string.

It allows a specific length and a number of digits after the decimal points.

- If **WIDTH** is 0 (zero), the string is formatted with the necessary length.

```
Q := NUM_TO_STRING (1.333333, 0, 2);    (* Q is '1.33' *)
```

- If **WIDTH** is greater than 0 (zero), the string is completed with leading blank characters in order to match the value of **WIDTH**.

```
Q := NUM_TO_STRING (123.4, 8, 2);    (* Q is ' 123.40' *)
```

- If **WIDTH** is greater than 0 (zero), the string is completed with trailing blank characters in order to match the value of **WIDTH**.

```
Q := NUM_TO_STRING (123.4, -8, 2);    (* Q is '123.40 ' *)
```

- If **DIGITS** is 0 (zero) then neither decimal part nor decimal point are added.

```
Q := NUM_TO_STRING (1.333333, 3, 0);    (* Q is ' 1' *)
```

- If **DIGITS** is greater than 0 (zero), the corresponding number of decimal digits are added. '0' digits are added if necessary

```
Q := NUM_TO_STRING (1.333333, 0, 1);    (* Q is '1.3' *)
```

- If the value is too long for the specified width, the string is filled with '*' characters.

```
Q := NUM_TO_STRING (1234, 3, 0);    (* Q is '***' *)
```

3.8.12 bcd_to_bin

PLCopen 

 **Function** - Converts a Binary Coded Decimal (BCD) value to a binary value.

Inputs

Input	Data Type	Range	Unit	Default	Description
IN	DINT				Integer value in BCD.

Outputs

Output	Data Type	Range	Unit	Description
Q	DINT			Converts a Binary Coded Decimal (BCD) value to a binary value. Value converted to integer or 0 (zero) if IN is not a valid positive BCD value.

Remarks

- The input must:
 - Be positive.
 - Represent a valid BCD value.

Truth Table

IN	Q
-2	0 (invalid)
0	0
16 (16#10)	10
15 (16#0F)	0 (invalid)

FBD Language Example

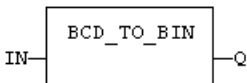

FFLD Language Example

- In the FFLD Language, the operation is executed only if the input rung (EN) is TRUE.
 - The output rung (ENO) keeps the same value as the input rung.

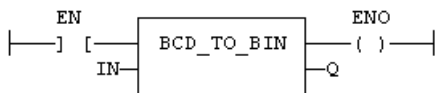

IL Language Example

- In the IL Language, the input must be loaded in the current result before calling the function.

```
Op1: LD      IN
      BCD_TO_BIN
      ST      Q
```

ST Language Example

```
Q := BCD_TO_BIN (IN);
```

See Also

bin_to_bcd

3.8.13 bin_to_bcd



 **Function** - Converts a binary value to a Binary Coded Decimal (BCD) value.

Inputs

Input	Data Type	Range	Unit	Default	Description
IN	DINT				Integer value.

Outputs

Output	Data Type	Range	Unit	Description
Q	DINT			Converts a binary value to a Binary Coded Decimal (BCD) value. Value converted to BCD or 0 (zero) if IN is less than 0 (zero).

Remarks

- The input must be positive.

Truth Table

IN	Q
-2	0 (invalid)
0	0
10	16 (16#10)
22	34 (16#22)

FBD Language Example

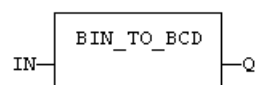

FFLD Language Example

- In the FFLD Language, the operation is executed only if the input rung (EN) is TRUE.
 - The output rung (ENO) keeps the same value as the input rung.

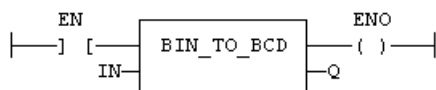

IL Language Example

- In the IL Language, the input must be loaded in the current result before calling the function.

```
Op1: LD      IN
      BIN_TO_BCD
      ST      Q
```

ST Language Example

```
Q := BIN_TO_BCD (IN);
```

See Also

[bcd_to_bin](#)

3.9 Counters

These are the standard function blocks for managing counters:

Function Block	Description
CTD / CTD _r	Down counter.
CTU / CTU _r	Up counter.
CTUD / CTUD _r	Up/down counter.

3.9.1 CTD / CTD_r



Function Block - Down counter.

Inputs

Input	Data Type	Range	Unit	Default	Description
CD	BOOL				Enable counting. Counter is decreased on each call when CD is TRUE.
LOAD	BOOL				Re-load command. Counter is set to PV when called with LOAD to TRUE.
PV	DINT				Programmed maximum value.

Outputs

Output	Data Type	Range	Unit	Description
CV	DINT			Current value of the counter.
Q	BOOL			TRUE when counter is empty (i.e., when CV = 0).

Remarks

- The counter is empty (CV = 0) when the application starts.
- The counter does not include a pulse detection for CD input.
- Use the "f_trig" (→ p. 113) or "r_trig" (→ p. 118) function blocks for counting pulses of CD input signal.
- CTD_r, CTU_r, and CTUD_r function blocks operate exactly as other counters.
 - Exception: All Boolean inputs (CU, CD, RESET, LOAD) have an implicit rising edge detection included.

FBD Language Example

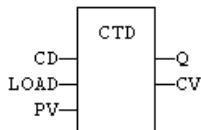

FFLD Language Example

- The CD is the input rung.
- The output rung is the Q output.

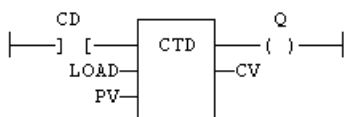

IL Language Example

```
(* MyCounter is a declared instance of CTD function block. *)
Op1: CAL    MyCounter (CD, LOAD, PV)
FFLD      MyCounter.Q
ST       Q
FFLD      MyCounter.CV
ST       CV
```

ST Language Example

```
(* MyCounter is a declared instance of CTD function block. *)
MyCounter (CD, LOAD, PV);
Q := MyCounter.Q;
CV := MyCounter.CV;
```

See Also

- CTU / CTU_r
- CTUD / CTUD_r

3.9.2 CTU / CTU_r



 Function Block - Up counter.

Inputs

Input	Data Type	Range	Unit	Default	Description
CU	BOOL				Enable counting. Counter is increased on each call when CU is TRUE.
PV	DINT				Programmed maximum value.
RESET	BOOL				Reset command. Counter is reset to 0 when called with RESET to TRUE.

Outputs

Output	Data Type	Range	Unit	Description
CV	DINT			Current value of the counter.
Q	BOOL			TRUE when counter is full (i.e., when CV = PV).

Remarks

- The counter is empty (CV = 0) when the application starts.
- The counter does not include a pulse detection for CU input.
- Use the "f_trig" (→ p. 113) or "r_trig" (→ p. 118) function blocks for counting pulses of CU input signal.
- CTD_r, CTU_r, and CTUD_r function blocks operate exactly as other counters.
 - Exception: All Boolean inputs (CU, CD, RESET, LOAD) have an implicit rising edge detection included.

FBD Language Example

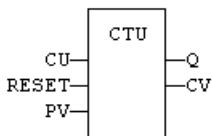

FFLD Language Example

- In the FFLD Language, CU is the input rung.
- The output rung is the Q output.

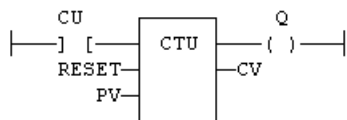

IL Language Example

```
(* MyCounter is a declared instance of CTU function block. *)
Op1: CAL    MyCounter (CU, RESET, PV)
FFLD      MyCounter.Q
ST        Q
```

```
FFLD    MyCounter.CV
ST      CV
```

ST Language Example

```
(* MyCounter is a declared instance of CTU function block. *)
MyCounter (CU, RESET, PV);
Q := MyCounter.Q;
CV := MyCounter.CV;
```

See Also

- CTD / CTD_r
- CTUD / CTUD_r

3.9.3 CTUD / CTUD_r

[PLCopen](#) 



Function Block - Up/down counter.

Inputs

Input	Data Type	Range	Unit	Default	Description
CD	BOOL				Enable counting. Counter is decreased on each call when CD is TRUE.
CU	BOOL				Enable counting. Counter is increased on each call when CU is TRUE.
LOAD	BOOL				Re-load command. Counter is set to PV when called with LOAD to TRUE.
PV	DINT				Programmed maximum value.
RESET	BOOL				Reset command. Counter is reset to 0 when called with RESET to TRUE.

Outputs

Output	Data Type	Range	Unit	Description
CV	DINT			Current value of the counter.
QD	BOOL			TRUE when counter is empty (i.e., when CV = 0).
QU	BOOL			TRUE when counter is full (i.e., when CV = PV).

3.9.3.1 Remarks

- The counter is empty (CV = 0) when the application starts.
- The counter does not include a pulse detection for CU and CD inputs.

- Use the "f_trig" (→ p. 113) or "r_trig" (→ p. 118) function blocks for counting pulses of CU or CD input signals.
- CTD_r, CTU_r, and CTUD_r function blocks operate exactly as other counters.
 - Exception: All Boolean inputs (CU, CD, RESET, LOAD) have an implicit rising edge detection included.

FBD Language Example

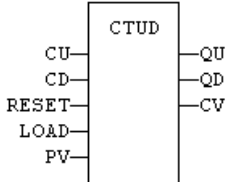

FFLD Language Example

- In the FFLD Language, CU is the input rung.
 - The output rung is the QU output.

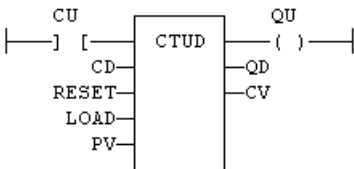

IL Language Example

```
(* MyCounter is a declared instance of CTUD function block. *)
Op1: CAL    MyCounter (CU, CD, RESET, LOAD, PV)
FFLD      MyCounter.QU
ST        QU
FFLD      MyCounter.QD
ST        QD
FFLD      MyCounter.CV
ST        CV
```

ST Language Example

```
(* MyCounter is a declared instance of CTUD function block. *)
MyCounter (CU, CD, RESET, LOAD, PV);
QU := MyCounter.QU;
QD := MyCounter.QD;
CV := MyCounter.CV;
```

See Also

"CTU/CTU_r" (→ p. 187)

3.10 Mathematic Operations



These are the mathematic calculation functions:

Name	Description
abs / absL	Returns the absolute value of the input.
EXP / EXPL	Calculates the natural exponential of the input.
expt	Calculates a power.
LN / LNL	Calculates the natural logarithm of the input.
log / logL	Calculates the logarithm (base 10) of the input.
pow / powL	Calculates a power.
root	Calculates the Nth root of the input.
ScaleLin	Scaling - linear conversion.
sqrt / sqrtL	Calculates the square root of the input.
trunc / truncL	Truncates the decimal part of the input.

3.10.1 abs / absL



 **Function** - Returns the absolute value of the input.

Inputs

Input	Data Type	Range	Unit	Default	Description
IN	REAL / LREAL				Any value.

Outputs

Output	Data Type	Range	Unit	Description
Q	REAL / LREAL			Result: Absolute value of IN.

Remarks

None

FBD Language Example

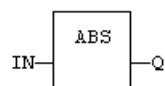

FFLD Language Example

- In the FFLD Language, the operation is executed only if the input rung (EN) is TRUE.
 - The output rung (ENO) keeps the same value as the input rung.

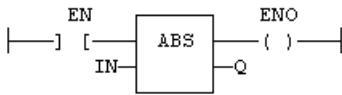

IL Language Example

- In the IL Language, the input must be loaded in the current result before calling the function.

```
Op1: LD IN
      ABS
      ST Q (* Q is: ABS (IN) *)
```

ST Language Example

```
Q := ABS (IN);
```

See Also

- log / logL
- pow / powL
- sqrt / sqrtL
- trunc / truncL

3.10.2 expt

[PLCopen](#)



Function - Calculates a power.

Inputs

Input	Data Type	Range	Unit	Default	Description
IN	REAL				Real value.
EXP	DINT				Exponent.

Outputs

Output	Data Type	Range	Unit	Description
Q	REAL			Result: IN at the EXP power.

Remarks

The exponent (second input of the function) must be the operand of the function.

FBD Language Example

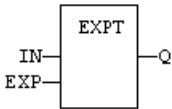

FFLD Language Example

- In the FFLD Language, the conversion is executed only if the input rung (EN) is TRUE.
 - The output rung (ENO) keeps the same value as the input rung.
 - The function is executed only if EN is TRUE.
 - ENO keeps the same value as EN.

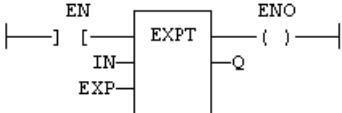

IL Language Example

- In the IL Language, the input must be loaded in the current result before calling the function.

```
Op1: LD    IN
      EXP  EXP
      ST    Q    (* Q is: (IN ** EXP) *)
```

ST Language Example

```
Q := EXP (IN, EXP);
```

See Also

- abs / absL
- log / logL
- pow / powL
- sqrt / sqrtL
- trunc / truncL

3.10.3 EXP / EXPL



 **Function** - Calculates the natural exponential of the input.

Inputs

Input	Data Type	Range	Unit	Default	Description
IN	REAL / LREAL				Real value.

Outputs

Output	Data Type	Range	Unit	Description
Q	REAL / LREAL			Result: Natural exponential of IN.

Remarks

None

FBD Language Example

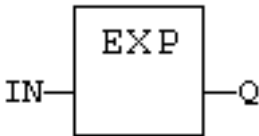

FFLD Language Example

- In the FFLD Language, the conversion is executed only if the input rung (EN) is TRUE.
 - The output rung (ENO) keeps the same value as the input rung.
 - The function is executed only if EN is TRUE.
 - ENO has the same value as EN.

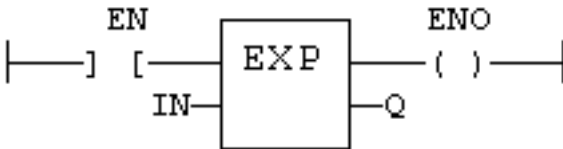

IL Language Example

- In the IL Language, the first input must be loaded before the function call.

```
Op1: LD  IN
      EXP
      ST  Q    (* Q is: EXP (IN) *)
```

ST Language Example

```
Q := EXP (IN);
```

3.10.4 log / logL

PLCopen 



Function - Calculates the logarithm (base 10) of the input.

Inputs

Input	Data Type	Range	Unit	Default	Description
IN	REAL / LREAL				Real value.

Outputs

Output	Data Type	Range	Unit	Description
Q	REAL / LREAL			Result: Logarithm (base 10) of IN.

Remarks

None

FBD Language Example

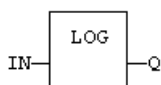

FFLD Language Example

- In the FFLD Language, the operation is executed only if the input rung (EN) is TRUE.
 - The output rung (ENO) keeps the same value as the input rung.
 - The function is executed only if EN is TRUE.
 - ENO has the same value as EN.

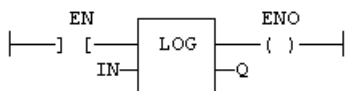

IL Language Example

- In the IL Language, the first input must be loaded before the function call.

```
Op1: LD IN
      LOG
      ST Q      (* Q is: LOG (IN) *)
```

ST Language Example

```
Q := LOG (IN);
```

See Also

- abs / absL
- pow / powL
- sqrt / sqrtL
- trunc / truncL

3.10.5 LN / LNL



Function - Calculates the natural logarithm of the input.

Inputs

Input	Data Type	Range	Unit	Default	Description
IN	REAL / LREAL				Real value.

Outputs

Output	Data Type	Range	Unit	Description
Q	REAL / LREAL			Result: Natural logarithm of IN.

Remarks

None

FBD Language Example

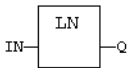

FFLD Language Example

- In the FFLD Language, the operation is executed only if the input rung (EN) is TRUE.
 - The output rung (ENO) keeps the same value as the input rung.
 - The function is executed only if EN is TRUE.
 - ENO has the same value as EN.

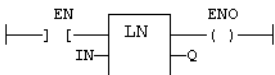

IL Language Example

In the IL Language, the input must be loaded in the current result before calling the function.

```
Op1: LD  IN
      LN
      ST  Q    (* Q is: LN (IN) *)
```

ST Language Example

```
Q := LN (IN);
```

3.10.6 pow / powL



Function - Calculates a power.

Inputs

Input	Data Type	Range	Unit	Default	Description
IN	REAL / LREAL				Real value.
EXP	REAL / LREAL				Exponent.

Outputs

Output	Data Type	Range	Unit	Description
Q	REAL / LREAL			Result: IN at the EXP power.

Remarks

None

FBD Language Example

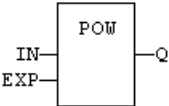

FFLD Language Example

- In the FFLD Language, the operation is executed only if the input rung (EN) is TRUE.
 - The output rung (ENO) keeps the same value as the input rung.
 - The function is executed only if EN is TRUE.
 - ENO keeps the same value as EN.

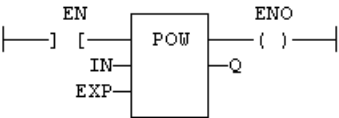

IL Language Example

- In the IL Language, the input must be loaded in the current result before calling the function.
 - The exponent (second input of the function) must be the operand of the function.

```
Op1: LD IN
      POW EXP
      ST Q      (* Q is: (IN ** EXP) *)
```

ST Language Example

- In the ST Language, the ** operator can be used.

```
Q := POW (IN, EXP);
Q := IN ** EXP;
```

See Also

- abs / absL
- expt
- log / logL
- sqrt / sqrtL
- trunc / truncL

3.10.7 root



Function - Calculates the Nth root of the input.

Inputs

Input	Data Type	Range	Unit	Default	Description
IN	REAL				Real value.
N	DINT				Root level.

Outputs

Output	Data Type	Range	Unit	Description
Q	REAL			Result: Nth root of IN.

Remarks

None

3.10.7.1 FBD Language

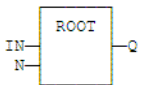

FFLD Language Example

- In the FFLD Language, the operation is executed only if the input rung (EN) is TRUE.
 - The output rung (ENO) keeps the same value as the input rung.
 - The function is executed only if EN is TRUE.
 - ENO keeps the same value as EN.

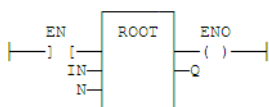

IL Language Example

- In the IL Language, the input must be loaded in the current result before calling the function.

```
Op1: LD  IN
      ROOT N
      ST  Q   (* Q is: ROOT (IN) *)
```

ST Language Example

```
Q := ROOT (IN, N);
```

3.10.8 ScaleLin



Function - Scaling - linear conversion.

Inputs

Input	Data Type	Range	Unit	Default	Description
IN	REAL				Real value.
IMIN	REAL				Minimum input value.
IMAX	REAL				Maximum input value.
OMIN	REAL				Minimum output value.
OMAX	REAL				Maximum output value.

Outputs

Output	Data Type	Range	Unit	Description
Q	REAL			Result: $OMIN + IN * (OMAX - OMIN) / (IMAX - IMIN)$.

Remarks

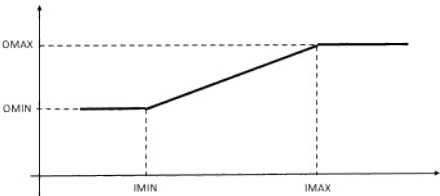

Truth Table

Inputs	OUT
IMIN >= IN IMAX	= IN
IN < IMIN	= OMIN
IN > IMAX	= OMAX
other	= OMIN + IN * (OMAX - OMIN) / (IMAX - IMIN)

FBD Language Example

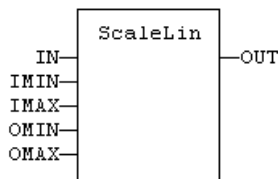

FFLD Language Example

- In the FFLD Language, the operation is executed only if the input rung (EN) is TRUE.
 - The output rung (ENO) keeps the same value as the input rung.
 - The function is executed only if EN is TRUE.
 - ENO keeps the same value as EN.

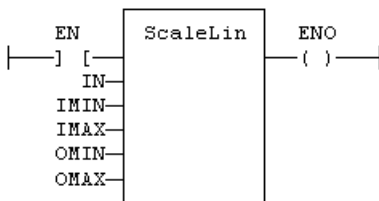

IL Language Example

- In the IL Language, the input must be loaded in the current result before calling the function.

```
Op1: LD      IN
      ScaleLin IMAX, IMIN, OMAX, OMIN
      ST      OUT
```

ST Language Example

```
OUT := ScaleLin (IN, IMIN, IMAX, OMIN, OMAX);
```

3.10.9 sqrt / sqrtL

PLCopen 

 **Function-** Calculates the square root of the input.

Inputs

Input	Data Type	Range	Unit	Default	Description
IN	REAL / LREAL				Real value.

Outputs

Output	Data Type	Range	Unit	Description
Q	REAL / LREAL			Result: Square root of IN.

Remarks

None

FBD Language Example

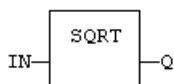

FFLD Language Example

- In the FFLD Language, the operation is executed only if the input rung (EN) is TRUE.
 - The output rung (ENO) keeps the same value as the input rung.
 - The function is executed only if EN is TRUE.
 - ENO keeps the same value as EN.

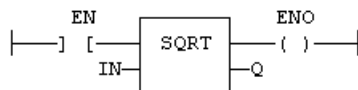

IL Language Example

- In the IL Language, the first input must be loaded before the function call.

```
Op1: LD IN
      SQRT
      ST Q      (* Q is: SQRT (IN) *)
```

ST Language Example

```
Q := SQRT (IN);
```

See Also

- "abs / absL" (→ p. 191)
- "log / logL" (→ p. 194)

- "pow / powL" (→ p. 196)
- "trunc / truncL" (→ p. 202)

3.10.10 trunc / truncL



Function - Truncates the decimal part of the input.

Inputs

Input	Data Type	Range	Unit	Default	Description
IN	REAL / LREAL				Real value.

Outputs

Output	Data Type	Range	Unit	Description
Q	REAL / LREAL			Result: Integer part of N.

Remarks

None

FBD Language Example

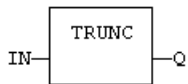

FFLD Language Example

- In the FFLD Language, the operation is executed only if the input rung (EN) is TRUE.
 - The output rung (ENO) keeps the same value as the input rung.
 - The function is executed only if EN is TRUE.
 - ENO keeps the same value as EN.

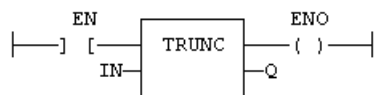

IL Language Example

- In the IL Language, the input must be loaded in the current result before calling the function.

```
Op1: LD IN
      TRUNC
      ST Q      (* Q is the integer part of IN *)
```

ST Language Example

```
Q := TRUNC (IN);
```

See Also

- "abs / absL" (→ p. 191)
- "log / logL" (→ p. 194)
- "pow / powL" (→ p. 196)
- "sqrt / sqrtL" (→ p. 200)

3.11 Miscellaneous Functions

PLCopen ✓

These are the miscellaneous functions:

Name	Description
EnableEvents	Enable or disable the production of events for binding (runtime to runtime variable exchange).
GetSysInfo	Get system information.

3.11.1 EnableEvents

PLCopen ✓

 **Function** - Enable or disable the production of events for binding (runtime to runtime variable exchange).

Inputs

Input	Data Type	Range	Unit	Default	Description
EN	BOOL	FALSE, TRUE			<ul style="list-style-type: none"> • TRUE to enable events. • FALSE to disable events.

Outputs

Output	Data Type	Range	Unit	Description
ENO	BOOL	FALSE, TRUE		Echo of EN input.

Remarks

- Production is enabled when the application starts.
- The first production is operated after the first cycle.
- To disable events since the beginning, you must call `EnableEvents (FALSE)` in the very first cycle.

FBD Language Example

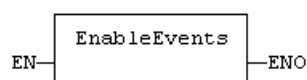

FFLD Language Example

- The input rung (EN) enables the event production.
 - The output rung keeps the state of the input rung.
 - Events are enables if EN is TRUE.
 - ENO has the same value as EN.

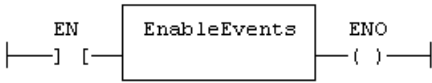

IL Language Example

- In the IL Language, the first input must be loaded before the function call.

```
Op1: LD EN
      EnableEvents
      ST ENO
```

ST Language Example

```
ENO := EnableEvents (EN);
```

See Also

Alarm_A

3.11.2 GetSysInfo



Function - Get system information.

Inputs

Input	Data Type	Range	Unit	Default	Description
INFO	DINT				Identifier of the requested information.

Outputs

Output	Data Type	Range	Unit	Description
Q	DINT			Value of the requested information or 0 (zero) if error.

Remarks

The INFO parameter can be one of these predefined values:

Value	Definition
_SYSINFO_APPSTAMP	Compiling date stamp of the application.
_SYSINFO_BIGENDIAN	Non zero if the runtime processor is big endian.

Value	Definition
_SYSINFO_CHANGE_CYCLE	Indicates a cycle just after an Online Change
_SYSINFO_CODECRC	CRC of the application code.
_SYSINFO_CYCLECOUNT	Counter of cycles.
_SYSINFO_CYCLEMAX_MICROS	Maximum detected cycle time in micro-seconds.
_SYSINFO_CYCLEMAX_MS	Maximum detected cycle time in milliseconds.
_SYSINFO_CYCLEOVERFLOWS	Number of detected cycle time overflows.
_SYSINFO_CYCLESTAMP_MS	Timestamp of the current cycle in milliseconds (OEM dependent).
_SYSINFO_CYCLETIME_MICROS	Duration of the previous cycle in micro-seconds.
_SYSINFO_CYCLETIME_MS	Duration of the previous cycle in milliseconds.
_SYSINFO_DATACRC	CRC of the application symbols.
_SYSINFO_DBSIZE	Space used in RAM (bytes).
_SYSINFO_DEMOAPP	Non zero if the application was compiled in DEMO mode.
_SYSINFO_ELAPSED	Seconds elapsed since startup.
_SYSINFO_FREEHEAP	Available space in memory heap (bytes).
_SYSINFO_NBBREAKPOINTS	Number of installed breakpoints.
_SYSINFO_NBLOCKED	Number of locked variables.
_SYSINFO_TRIGGER_MICROS	Programmed cycle time in micro-seconds.
_SYSINFO_TRIGGER_MS	Programmed cycle time in milliseconds.
_SYSINFO_WARMSTART	Non zero if RETAIN variables were loaded at the last start.

FBD Language Example

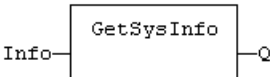

FFLD Language Example

- In the FFLD Language, the operation is executed only if the input rung (EN) is TRUE.
 - The output rung (ENO) keeps the same value as the input rung.
- The function is executed only if EN is TRUE.
- ENO keeps the same value as EN.

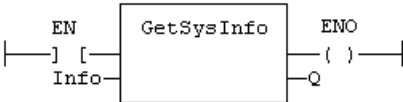

IL Language Example

- In the IL Language, the input must be loaded in the current result before calling the function.

```
Op1: LD  INFO
      GETSYSINFO
      ST  Q
```

ST Language Example

```
Q := GETSYSINFO (INFO);
```

3.12 Registers

- "All Register Functions (Alphabetically)" (→ p. 206)
 - "Advanced Function" (→ p. 206)
 - "Bit Access" (→ p. 207)
 - "Bit-to-Bit Functions" (→ p. 207)
 - "Pack / Unpack Functions" (→ p. 207)
 - "Standard Functions" (→ p. 207)

3.12.1 All Register Functions (Alphabetically)

Name	Description
and_mask	Performs a bit-to-bit Boolean AND between two integer values.
HiByte	Get the highest byte of a word.
HiWord	Get the highest word of a double word.
LoByte	Get the lowest byte of a word.
LoWord	Get the lowest word of a double word.
MakeDWord	Builds a double word as the concatenation of two words.
MakeWord	Builds a word as the concatenation of two bytes.
MBshift	Multi-byte shift / rotate.
not_mask	Performs a bit-to-bit Boolean negation of an integer value.
or_mask	Performs a bit-to-bit Boolean OR between two integer values.
PACK8	Pack bits in a byte.
rol	Rotate bits of a register to the left.
ror	Rotate bits of a register to the right.
SetBit	Set a bit in an integer register.
shl	Shift bits of a register to the left.
shr	Shift bits of a register to the right.
TestBit	Test a bit of an integer register.
UNPACK8	Extract bits from a byte.
xor_mask	Performs a bit to bit exclusive OR between two integer values.

3.12.1.1 Advanced Function

This is the advanced function for register manipulation:

Name	Description
MBshift	Multi-byte shift / rotate.

3.12.1.2 Bit Access

These functions provide bit access from 8-bit to 32-bit integers:

Name	Description
SetBit	Set a bit in an integer register.
TestBit	Test a bit of an integer register.

3.12.1.3 Bit-to-Bit Functions

These functions enable bit-to-bit operations from 8-bit to 32-bit integers:

Name	Description
and_mask	Performs a bit-to-bit Boolean AND between two integer values.
not_mask	Performs a bit-to-bit Boolean negation of an integer value.
or_mask	Performs a bit-to-bit Boolean OR between two integer values.
xor_mask	Performs a bit to bit exclusive OR between two integer values.

3.12.1.4 Pack / Unpack Functions

These functions enable pack / unpack from 8-bit to 32-bit integers:

Name	Description
HiByte	Get the highest byte of a word.
HiWord	Get the highest word of a double word.
LoByte	Get the lowest byte of a word.
LoWord	Get the lowest word of a double word.
MakeDWord	Builds a double word as the concatenation of two words.
MakeWord	Builds a word as the concatenation of two bytes.
PACK8	Pack bits in a byte.
UNPACK8	Extract bits from a byte.

3.12.1.5 Standard Functions

These are the standard functions for managing 8- to 32-bit registers:

Name	Description
rol	Rotate bits of a register to the left.
ror	Rotate bits of a register to the right.
shl	Shift bits of a register to the left.
shr	Shift bits of a register to the right.

3.12.2 and_mask



 **Function** - Performs a bit-to-bit Boolean AND between two integer values.

Inputs

Input	Data Type	Range	Unit	Default	Description
IN	ANY				First input.
MSK	ANY				Second input. (AND mask)

Outputs

Output	Data Type	Range	Unit	Description
Q	ANY			AND mask between IN and MSK inputs.

Remarks

- Arguments can be signed or unsigned integers from 8- to 32-bits.

FBD Language Example

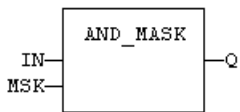

FFLD Language Example

- In the FFLD Language, the input rung (EN) enables the operation.
 - The output rung (ENO) keeps the same value as the input rung.
 - The function is executed only if EN is TRUE.
 - ENO is equal to EN.

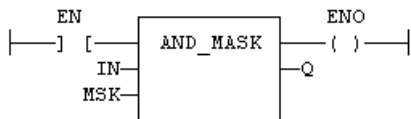

IL Language Example

- In the IL Language, the first parameter (IN) must be loaded in the current result before calling the function.
 - The other input is the operands of the function.

```

Op1: LD      IN
      AND_MASK MSK
      ST      Q
  
```

ST Language Example

```
Q := AND_MASK (IN, MSK);
```

See Also

- not_mask
- or_mask
- xor_mask

3.12.3 HiByte

PLCopen 

 Function - Get the highest byte of a word.

Inputs

Input	Data Type	Range	Unit	Default	Description
IN	UINT				16-bit register.

Outputs

Output	Data Type	Range	Unit	Description
Q	USINT			Highest significant byte.

Remarks

None

FBD Language Example

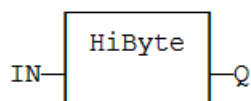

FFLD Language Example

- In the FFLD Language, the operation is executed only if the input rung (EN) is TRUE.
 - The output rung (ENO) keeps the same value as the input rung.
- The function is executed only if EN is TRUE.
- ENO keeps the same value as EN.

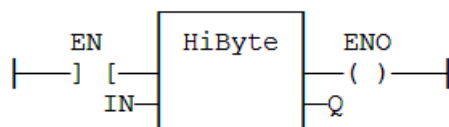

IL Language Example

- In the IL Language, the input must be loaded in the current result before calling the function.

```
Op1: LD  IN
      HIBYTE
      ST  Q
```

ST Language Example

```
Q := HIBYTE (IN);
```

See Also

- HiWord
- LoByte
- LoWord
- MakeDWord
- MakeWord

3.12.4 LoByte

PLCopen 



Function - Get the lowest byte of a word.

Inputs

Input	Data Type	Range	Unit	Default	Description
IN	UINT				16-bit register.

Outputs

Output	Data Type	Range	Unit	Description
Q	USINT			Lowest significant byte.

Remarks

None

FBD Language Example

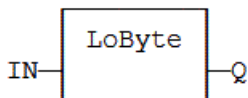

FFLD Language Example

- In the FFLD Language, the operation is executed only if the input rung (EN) is TRUE.
 - The output rung (ENO) keeps the same value as the input rung.

- The function is executed only if EN is TRUE.
- ENO keeps the same value as EN.

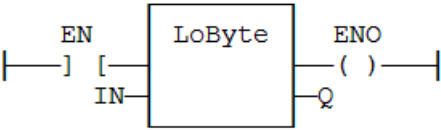

IL Language Example

- In the IL Language, the input must be loaded in the current result before calling the function.

```
Op1: LD IN
      LOBYTE
      ST Q
```

ST Language Example

```
Q := LOBYTE (IN);
```

See Also

- HiByte
- HiWord
- LoWord
- MakeDWord
- MakeWord

3.12.5 HiWord



Function - Get the highest word of a double word.

Inputs

Input	Data Type	Range	Unit	Default	Description
IN	UDINT				32-bit register.

Outputs

Output	Data Type	Range	Unit	Description
Q	UINT			Highest significant word.

Remarks

None

FBD Language Example

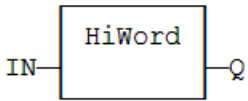

FFLD Language Example

- In the FFLD Language, the operation is executed only if the input rung (EN) is TRUE.
 - The output rung (ENO) keeps the same value as the input rung.
- The function is executed only if EN is TRUE.
- ENO keeps the same value as EN.

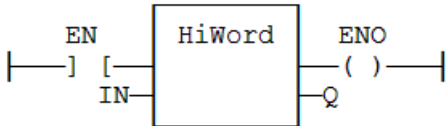

IL Language Example

- In the IL Language, the input must be loaded in the current result before calling the function.

```
Op1: LD  IN
      HIWORD
      ST  Q
```

ST Language Example

```
Q := HIWORD (IN);
```

See Also

- HiByte
- LoByte
- LoWord
- MakeDWord
- MakeWord

3.12.6 LoWord

[PLCopen](#)



Function - Get the lowest word of a double word.

Inputs

Input	Data Type	Range	Unit	Default	Description
IN	UDINT				32-bit register.

Outputs

Output	Data Type	Range	Unit	Description
Q	UINT			Lowest significant word.

Remarks

None

FBD Language Example

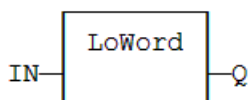

FFLD Language Example

- In the FFLD Language, the operation is executed only if the input rung (EN) is TRUE.
 - The output rung (ENO) keeps the same value as the input rung.
- The function is executed only if EN is TRUE.
- ENO keeps the same value as EN.

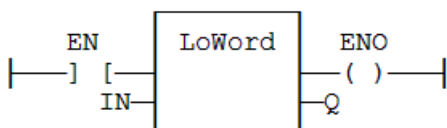

IL Language Example

- In the IL Language, the input must be loaded in the current result before calling the function.

```
Op1: LD  IN
      LOWORD
      ST  Q
```

ST Language Example

```
Q := LOWORD (IN);
```

See Also

- HiByte
- HiWord
- LoByte
- MakeDWord
- MakeWord

3.12.7 MakeDWord



 **Function** - Builds a double word as the concatenation of two words.

Inputs

Input	Data Type	Range	Unit	Default	Description
HI	USINT				Highest significant word.
LO	USINT				Lowest significant word.

Outputs

Output	Data Type	Range	Unit	Description
Q	UINT			32-bit register.

Remarks

None

FBD Language Example

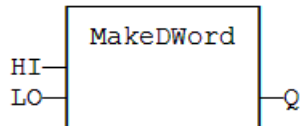

FFLD Language Example

- In the FFLD Language, the operation is executed only if the input rung (EN) is TRUE.
 - The output rung (ENO) keeps the same value as the input rung.
- The function is executed only if EN is TRUE.
- ENO keeps the same value as EN.

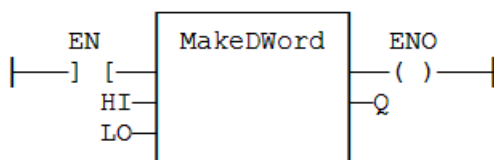

IL Language Example

- In the IL Language, the input must be loaded in the current result before calling the function.

```
Op1: LD      HI
      MAKEDWORD LO
      ST      Q
```

ST Language Example

```
Q := MAKEDWORD (HI, LO);
```

See Also

- HiByte
- HiWord
- LoByte
- LoWord
- MakeWord

3.12.8 MakeWord



Function - Builds a word as the concatenation of two bytes.

Inputs

Input	Data Type	Range	Unit	Default	Description
HI	USINT				Highest significant byte.
LO	USINT				Lowest significant byte.

Outputs

Output	Data Type	Range	Unit	Description
Q	UINT			16-bit register.

Remarks

None

FBD Language Example

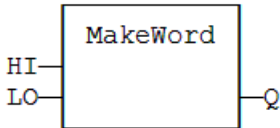

FFLD Language Example

- In the FFLD Language, the operation is executed only if the input rung (EN) is TRUE.
 - The output rung (ENO) keeps the same value as the input rung.
- The function is executed only if EN is TRUE.
- ENO keeps the same value as EN.

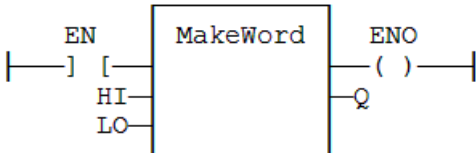

IL Language Example

- In the IL Language, the input must be loaded in the current result before calling the function.

```
Op1: LD      HI
      MAKEWORD LO
      ST      Q
```

ST Language Example

```
Q := MAKEWORD (HI, LO);
```

See Also

- HiByte
- HiWord
- LoByte
- LoWord
- MakeDWord

3.12.9 MBSHift

PLCopen 



Function - Multi-byte shift / rotate.

Inputs

Input	Data Type	Range	Unit	Default	Description
Buffer	SINT / USINT				Array of bytes.
Pos	DINT				Base position in the array.
NbByte	DINT				Number of bytes to be shifted or rotated.
NbShift	DINT				Number of shifts or rotations.
ToRight	BOOL	FALSE, TRUE			<ul style="list-style-type: none"> • TRUE for right. • FALSE for left.
Rotate	BOOL	FALSE, TRUE			<ul style="list-style-type: none"> • TRUE for rotate. • FALSE for shift.
InBit	BOOL	FALSE, TRUE			Bit to be introduced in a shift.

Outputs

Output	Data Type	Range	Unit	Description
Q	BOOL	FALSE, TRUE		TRUE if successful.

Remarks

- Use the **ToRight** argument to specify a shift to the left (FALSE) or to the right (TRUE).
- Use the **Rotate** argument to specify either a shift (FALSE) or a rotation (TRUE).
- In case of a shift, the **InBit** argument specifies the value of the bit that replaces the last shifted bit.

FBD Language Example

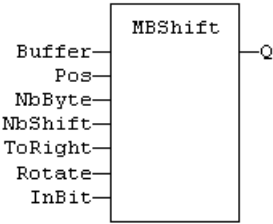

FFLD Language Example

- In the FFLD Language, the input rung (EN) enables the operation.
- The rung output is the result (Q).
- The function is called only if EN is TRUE.

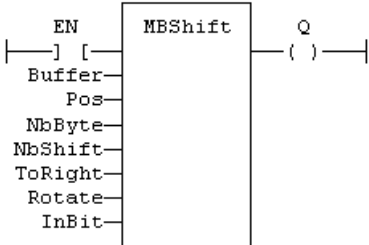

IL Language Example

Not available.

ST Language Example

```
Q := MBSHift (Buffer, Pos, NbByte, NbShift, ToRight, Rotate, InBit);
```

3.12.10 not_mask



Function - Performs a bit-to-bit Boolean negation of an integer value.

Inputs

Input	Data Type	Range	Unit	Default	Description
IN	ANY				Integer input.

Outputs

Output	Data Type	Range	Unit	Description
Q	ANY			Bit to bit negation of the input.

Remarks

- Arguments can be signed or unsigned integers from 8- to 32-bits.

FBD Language Example

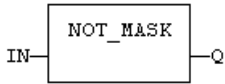

FFLD Language Example

- In the FFLD Language, the input rung (EN) enables the operation.
 - The output rung keeps the state of the input rung.
 - The function is executed only if EN is TRUE.
 - ENO has the same value as EN.

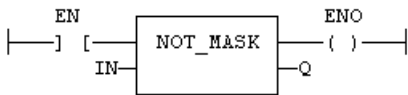

IL Language Example

- In the IL Language, the first parameter (IN) must be loaded in the current result before calling the function.
 - The other input is the operands of the function.

```
Op1: LD      IN
      NOT_MASK
      ST      Q
```

ST Language Example

```
Q := NOT_MASK (IN);
```

See Also

- and_mask
- or_mask
- xor_mask

3.12.11 or_mask



Function - Performs a bit-to-bit Boolean OR between two integer values.

Inputs

Input	Data Type	Range	Unit	Default	Description
IN	ANY				First input.
MSK	ANY				Second input. (OR mask)

Outputs

Output	Data Type	Range	Unit	Description
Q	ANY			OR mask between IN and MSK inputs.

Remarks

- Arguments can be signed or unsigned integers from 8- to 32-bits.

FBD Language Example

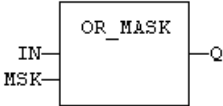

FFLD Language Example

- In the FFLD Language, the input rung (EN) enables the operation.
 - The output rung keeps the state of the input rung.
 - The function is executed only if EN is TRUE.
 - ENO has the same value as EN.

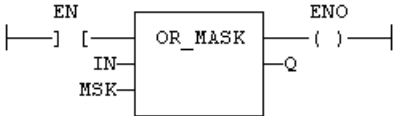

IL Language Example

- In the IL Language, the first parameter (IN) must be loaded in the current result before calling the function.
 - The other input is the operands of the function.

```
Op1: LD      IN
      OR_MASK MSK
      ST      Q
```

ST Language Example

```
Q := OR_MASK (IN, MSK);
```

See Also

- and_mask
- not_mask
- xor_mask

3.12.12 Pack8



 Function - Pack bits in a byte.

Inputs

Input	Data Type	Range	Unit	Default	Description
IN0	BOOL	FALSE, TRUE			Less significant bit.
IN7	BOOL	FALSE, TRUE			Highest significant bit.

Outputs

Output	Data Type	Range	Unit	Description
Q	USINT			Byte built with input bits.

Remarks

None

FBD Language Example

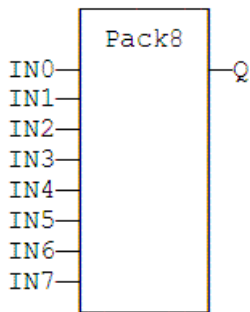

FFLD Language Example

- The input rung is the IN0 input.
 - The output rung (ENO) keeps the same value as the input rung.
- ENO keeps the same value as EN.

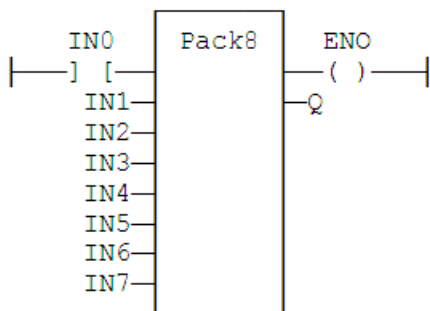

IL Language Example

- In the IL Language, the input must be loaded in the current result before calling the function.

```
Op1: LD    IN0
      PACK8 IN1, IN2, IN3, IN4, IN5, IN6, IN7
      ST    Q
```

ST Language Example

```
Q := PACK8 (IN0, IN1, IN2, IN3, IN4, IN5, IN6, IN7);
```

See Also

Unpack8

3.12.13 rol

[PLCopen](#)



Function - Rotate bits of a register to the left.

Inputs

Input	Data Type	Range	Unit	Default	Description
IN	ANY				Register.
NBR	DINT				Number of rotations (each rotation is 1 bit).

Outputs

Output	Data Type	Range	Unit	Description
Q	ANY			Rotated register.

Remarks

- Arguments can be signed or unsigned integers from 8- to 32-bits.

Diagram



FBD Language Example

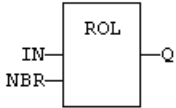

FFLD Language Example

- In the FFLD Language, the input rung (EN) enables the operation.
 - The output rung keeps the state of the input rung.
 - The rotation is executed only if EN is TRUE.
 - ENO keeps the same value as EN.

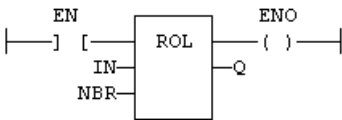

IL Language Example

- In the IL Language, the first input must be loaded before the function call.
 - The second input is the operand of the function.

```
Op1: LD  IN
      ROL NBR
      ST  Q
```

ST Language Example

```
Q := ROL (IN, NBR);
```

See Also

- "ror" (→ p. 222)
- "shl" (→ p. 226)
- "shr" (→ p. 227)

3.12.14 ror



 Function - Rotate bits of a register to the right.

Inputs

Input	Data Type	Range	Unit	Default	Description
IN	ANY				Register.
NBR	ANY				Number of rotations (each rotation is 1 bit).

Outputs

Output	Data Type	Range	Unit	Description
Q	ANY			Rotated register.

Remarks

- Arguments can be signed or unsigned integers from 8- to 32-bits.

Diagram



FBD Language Example

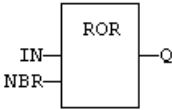

FFLD Language Example

- In the FFLD Language, the input rung (EN) enables the operation.
 - The output rung keeps the state of the input rung.
 - The rotation is executed only if EN is TRUE.
 - ENO keeps the same value as EN.

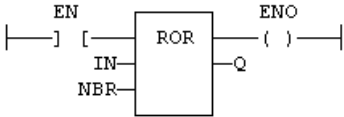

IL Language Example

- In the IL Language, the first input must be loaded before the function call.
 - The second input is the operand of the function.

```
Op1: LD IN
      ROR NBR
      ST Q
```

ST Language Example

```
Q := ROR (IN, NBR);
```

See Also

- "rol" (→ p. 221)
- "shl" (→ p. 226)
- "shr" (→ p. 227)

3.12.15 SetBit

PLCopen 



Function - Set a bit in an integer register.

Inputs

Input	Data Type	Range	Unit	Default	Description
IN	ANY				8- to 64-bit integer register.
BIT	DINT				Bit number (0 = less significant bit).
VAL	BOOL	FALSE, TRUE			Bit value to apply.

Outputs

Output	Data Type	Range	Unit	Description
Q	ANY			Modified register.

Remarks

- Types LINT, LREAL, REAL, STRING, and TIME are not supported for IN and Q.
- IN and Q must have the same type.
- In case of invalid arguments (e.g., bad bit number or invalid input type), the function returns the value of IN without modification.

FBD Language Example

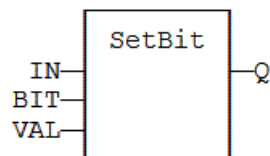

FFLD Language Example

- In the FFLD Language, the conversion is executed only if the input rung (EN) is TRUE.
 - The output rung (ENO) keeps the same value as the input rung.
- The function is executed only if EN is TRUE.
- ENO keeps the same value as EN.

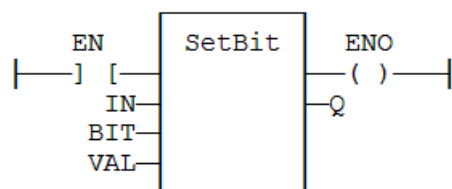

IL Language Example

Not available.

ST Language Example

```
Q := SETBIT (IN, BIT, VAL);
```

See Also

"TestBit" (→ p. 230)

3.12.16 shl

PLCopen 



Function - Shift bits of a register to the left.

Inputs

Input	Data Type	Range	Unit	Default	Description
IN	ANY				Register.
NBS	ANY				Number of shifts (each shift is 1 bit).

Outputs

Output	Data Type	Range	Unit	Description
Q	ANY			Shifted register.

Remarks

- Arguments can be signed or unsigned integers from 8- to 32-bits.

Diagram

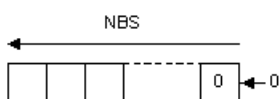

FBD Language Example

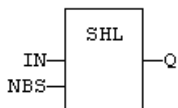

FFLD Language Example

- In the FFLD Language, the input rung (EN) enables the operation.
 - The output rung keeps the state of the input rung.
 - The shift is executed only if EN is TRUE.
 - ENO has the same value as EN.

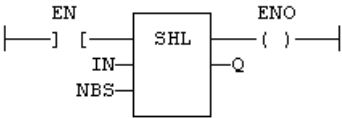

IL Language Example

- In the IL Language, the first input must be loaded before the function call.
 - The second input is the operand of the function.

```
Op1: LD IN
      SHL NBS
      ST Q
```

ST Language Example

```
Q := SHL (IN, NBS);
```

See Also

- "rol" (→ p. 221)
- "ror" (→ p. 222)
- "shr" (→ p. 227)

3.12.17 shr



Function - Shift bits of a register to the right.

Inputs

Input	Data Type	Range	Unit	Default	Description
IN	ANY				Register.
NBS	ANY				Number of shifts (each shift is 1 bit).

Outputs

Output	Data Type	Range	Unit	Description
Q	ANY			Shifted register.

Remarks

- Arguments can be signed or unsigned integers from 8- to 32-bits.

Diagram

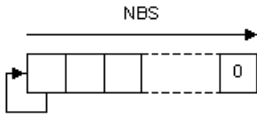

FBD Language Example

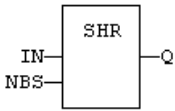

FFLD Language Example

- In the FFLD Language, the input rung (EN) enables the operation.
 - The output rung keeps the state of the input rung.
 - The shift is executed only if EN is TRUE.
 - ENO has the same value as EN.

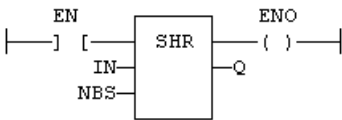

IL Language Example

- In the IL Language, the first input must be loaded before the function call.
 - The second input is the operand of the function.

```
Op1: LD IN
      SHR NBS
      ST Q
```

ST Language Example

```
Q := SHR (IN, NBS);
```

See Also

- "rol" (→ p. 221)
- "ror" (→ p. 222)
- "shl" (→ p. 226)

3.12.18 SWAB



Function - Swap the bytes of an integer.

Inputs

Input	Data Type	Range	Unit	Default	Description
IN	ANY	No range	N/A	No default	Any signed or unsigned integer.

Outputs

Output	Data Type	Range	Unit	Description
Q	ANY	No range	N/A	Swapped value.

Remarks

Supported data types are:

- DINT
- DWORD
- INT
- LINT
- LWORD
- SINT
- UDINT
- UINT
- ULINT
- USINT
- WORD

- SINT and USINT inputs result in the same output value because they are only 1 byte wide.
- If the function is called for another data type, the output takes the value of the input.

3.12.18.0.1 Examples

Type	IN	Q
DWORD	16#1A2B3C4D	16#4D3C2B1A
WORD	16#1A2B	16#2B1A

FBD Language Example

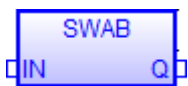

FFLD Language Example

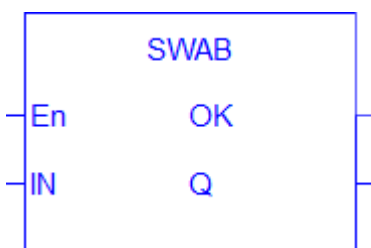

IL Language Example

Not available.

ST Language Example

```
swappedValue := SWAB(value);
```

3.12.19 TestBit



Function - Test a bit of an integer register.

Inputs

Input	Data Type	Range	Unit	Default	Description
IN	ANY				8- to 64-bit integer register.
BIT	DINT				Bit number (0 = less significant bit).

Outputs

Output	Data Type	Range	Unit	Description
Q	BOOL	FALSE, TRUE		Bit value.

Remarks

- Types LINT, LREAL, REAL, STRING, and TIME are not supported for IN and Q.
- IN and Q must have the same type.
- In case of invalid arguments (e.g., bad bit number or invalid input type), the function returns FALSE.

FBD Language Example

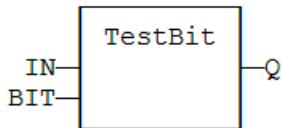

FFLD Language Example

- In the FFLD Language, the operation is executed only if the input rung (EN) is TRUE.
 - The output rung is the output of the function.
 - The function is executed only if EN is TRUE.

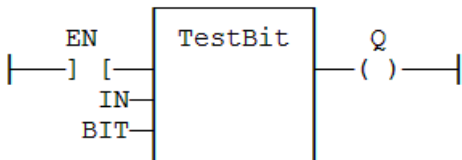

IL Language Example

Not available.

ST Language Example

```
Q := TESTBIT (IN, BIT);
```

See Also

"SetBit" (→ p. 225)

3.12.20 Unpack8



Function Block - Extract bits from a byte.

Inputs

Input	Data Type	Range	Unit	Default	Description
IN	USINT				8-bit register.

Outputs

Output	Data Type	Range	Unit	Description
Q0	BOOL	FALSE, TRUE		Less significant bit.
Q7	BOOL	FALSE, TRUE		Highest significant bit.

Remarks

- The operation is executed only in the input rung (EN) is TRUE.

FBD Language Example

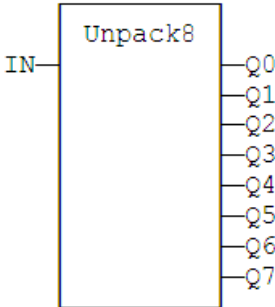

FFLD Language Example

- In the FFLD language, the output rung is the Q0 output.
- The operation is performed if EN = TRUE.

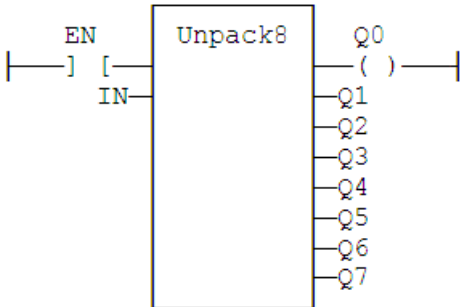

IL Language Example

```
(* MyUnpack is a declared instance of the UNPACK8 function block *)
Op1: CAL MyUnpack (IN)
    FFLD MyUnpack.Q0
    ST Q0
    (* ... *)
    FFLD MyUnpack.Q7
    ST Q7
```

ST Language Example

```
(* MyUnpack is a declared instance of the UNPACK8 function block *)
MyUnpack (IN);
Q0 := MyUnpack.Q0;
Q1 := MyUnpack.Q1;
Q2 := MyUnpack.Q2;
Q3 := MyUnpack.Q3;
Q4 := MyUnpack.Q4;
Q5 := MyUnpack.Q5;
Q6 := MyUnpack.Q6;
Q7 := MyUnpack.Q7;
```

See Also

"Pack8" (→ p. 220)

3.12.21 xor_mask



 **Function** - Performs a bit to bit exclusive OR between two integer values.

Inputs

Input	Data Type	Range	Unit	Default	Description
IN	ANY				First input.
MSK	ANY				Second input. (XOR mask)

Outputs

Output	Data Type	Range	Unit	Description
Q	ANY			Exclusive OR mask between IN and MSK inputs.

Remarks

- Arguments can be signed or unsigned integers from 8- to 32-bits.

FBD Language Example

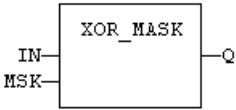

FFLD Language Example

- In the FFLD Language, the input rung (EN) enables the operation.
 - The output rung keeps the state of the input rung.
 - The function is executed only if EN is TRUE.
 - ENO has the same value as EN.

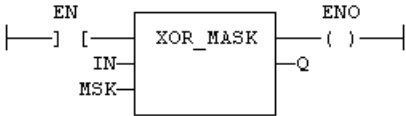

IL Language Example

- In the IL Language, the input must be loaded in the current result before calling the function.
 - The other input is the operands of the function.

```
Op1: LD      IN
      XOR_MASK MSK
      ST      Q
```

ST Language Example

```
Q := XOR_MASK (IN, MSK);
```

See Also

- "and_mask" (→ p. 208)
- "not_mask" (→ p. 217)
- "or_mask" (→ p. 218)

3.13 Selectors

These are the standard functions that perform data selection:

Name	Description
mux	Select one of the eight integer inputs.
mux4	Select one of the four integer inputs.
mux8	Select one of the eight integer inputs.
mux64	Select one of the 64 integer inputs.
sel	Select one of the two integer inputs.

3.13.1 mux

PLCopen 



Function - Select one of the eight integer inputs.

The mux function is for the ST Language only.

Inputs

Input	Data Type	Range	Unit	Default	Description
K	DINT	0 to 7	N/A	No default	Selection command.
IN0	ANY	Depends on the Data Type.	N/A	No default	First input.
IN1	ANY	Depends on the Data Type.	N/A	No default	Second input.
IN2	ANY	Depends on the Data Type.	N/A	No default	Third input.
IN3	ANY	Depends on the Data Type.	N/A	No default	Fourth input.
IN4	ANY	Depends on the Data Type.	N/A	No default	Fifth input.
IN5	ANY	Depends on the Data Type.	N/A	No default	Sixth input.
IN6	ANY	Depends on the Data Type.	N/A	No default	Seventh input.
IN7	ANY	Depends on the Data Type.	N/A	No default	Last input.

Outputs

Output	Data Type	Range	Unit	Description
Q	ANY	No range	N/A	IN0 or IN1 ... or IN7 depending on K. See the Truth Table .

Remarks

None

3.13.1.0.1

Truth Table

K	Q
0	IN0
1	IN1
2	IN2
3	IN3
4	IN4
5	IN5
6	IN6
7	IN7
Other	0

FBD Language Example

Not available.

FPLD Language Example

Not available.

IL Language Example

Not available.

3.13.1.0.2

ST Language Example

```
Q := MUX (K, IN0, IN1, IN2, IN3, IN4, IN5, IN6, IN7);
```

See Also

- "mux4" (→ p. 235)
- "mux8" (→ p. 237)
- "mux64" (→ p. 238)
- "sel" (→ p. 240)

3.13.2 mux4

[PLCopen](#) 



Function - Select one of the four integer inputs.

Inputs

Input	Data Type	Range	Unit	Default	Description
K	DINT	0 to 3	N/A	No default	Selection command.
IN0	ANY	Depends on the Data Type.	N/A	No default	First input.
IN1	ANY	Depends on the Data Type.	N/A	No default	Second input.
IN2	ANY	Depends on the Data Type.	N/A	No default	Third input.
IN3	ANY	Depends on the Data Type.	N/A	No default	Last input.

Outputs

Output	Data Type	Range	Unit	Description
Q	ANY	No range	N/A	IN0 or IN1 ... or IN3 depending on K. See the Truth Table .

Remarks

None

3.13.2.0.1

Truth Table

K	Q
0	IN0
1	IN1
2	IN2
3	IN3
Other	0

FBD Language Example

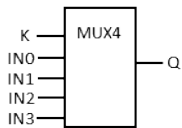

FFLD Language Example

- In the FFLD Language, the input rung (EN) enables the selection.
 - The output rung keeps the state of the input rung.
 - The selection is performed only if EN is TRUE.
 - ENO has the same value as EN.

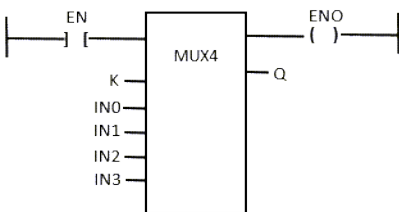

IL Language Example

- In the IL Language, the first parameter (selector) must be loaded in the current result before calling the function.
 - Other inputs are operands of the function, separated by comas.

```
Op1: LD    SELECT
      MUX4 IN1, IN2, IN3, IN4
      ST    Q
```

ST Language Example

```
Q := MUX4 (K, IN0, IN1, IN2, IN3);
```

See Also

- "mux" (→ p. 234)
- "mux8" (→ p. 237)
- "mux64" (→ p. 238)
- "sel" (→ p. 240)

3.13.3 mux8

 **Function** - Select one of the eight integer inputs.

Inputs

Input	Data Type	Range	Unit	Default	Description
K	DINT	0 to 7	N/A	No default	Selection command.
IN0	ANY	Depends on the Data Type.	N/A	No default	First input.
IN1	ANY	Depends on the Data Type.	N/A	No default	Second input.
IN2	ANY	Depends on the Data Type.	N/A	No default	Third input.
IN3	ANY	Depends on the Data Type.	N/A	No default	Fourth input.
IN4	ANY	Depends on the Data Type.	N/A	No default	Fifth input.
IN5	ANY	Depends on the Data Type.	N/A	No default	Sixth input.
IN6	ANY	Depends on the Data Type.	N/A	No default	Seventh input.
IN7	ANY	Depends on the Data Type.	N/A	No default	Last input.

Outputs

Output	Data Type	Range	Unit	Description
Q	ANY	No range	N/A	IN0 or IN1 ... or IN7 depending on K. See the Truth Table .

Remarks

None

3.13.3.0.1**Truth Table**

K	Q
0	IN0
1	IN1
2	IN2
3	IN3
4	IN4
5	IN5

K	Q
6	IN6
7	IN7
Other	0

FBD Language Example

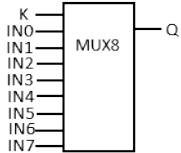

FFLD Language Example

- In the FFLD Language, the input rung (EN) enables the selection.
 - The output rung keeps the state of the input rung.
 - The selection is performed only if EN is TRUE.
 - ENO has the same value as EN.

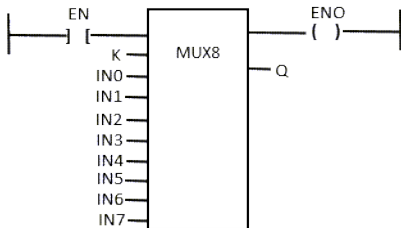

IL Language Example

Not available.

ST Language Example

```
Q := MUX8 (K, IN0, IN1, IN2, IN3, IN4, IN5, IN6, IN7);
```

See Also

- "mux" (→ p. 234)
- "mux4" (→ p. 235)
- "mux64" (→ p. 238)
- "sel" (→ p. 240)

3.13.4 mux64



 **Function** - Select one of the 64 integer inputs.

Inputs

Input	Data Type	Range	Unit	Default	Description
K	DINT	0 to 63	N/A	No default	Selection command.
IN0	ANY	Depends on the Data Type.	N/A	No default	First input.
IN1	ANY	Depends on the Data Type.	N/A	No default	Second input.
IN2	ANY	Depends on the Data Type.	N/A	No default	Third input.
IN3	ANY	Depends on the Data Type.	N/A	No default	Fourth input.
IN4	ANY	Depends on the Data Type.	N/A	No default	Fifth input.
IN5	ANY	Depends on the Data Type.	N/A	No default	Sixth input.
IN6	ANY	Depends on the Data Type.	N/A	No default	Seventh input.
IN7	ANY	Depends on the Data Type.	N/A	No default	Eighth input.
IN...	ANY	Depends on the Data Type.	N/A	No default	...
IN63	ANY	Depends on the Data Type.	N/A	No default	Last input.

Outputs

Output	Data Type	Range	Unit	Description
Q	ANY	Depends on the Data Type.	N/A	IN0 or IN1 ... or IN63 depending on K. See the Truth Table .

Remarks

None

3.13.4.0.1

Truth Table

K	Q
0	IN0
1	IN1
2	IN2
3	IN3
4	IN4
5	IN5
6	IN6
7	IN7
...	...
63	IN63
Other	0

FBD Language Example

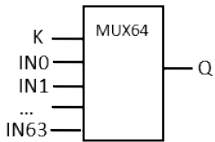

FFLD Language Example

- In the FFLD Language, the input rung (EN) enables the selection.
 - The output rung keeps the state of the input rung.
 - The selection is performed only if EN is TRUE.
 - ENO has the same value as EN.

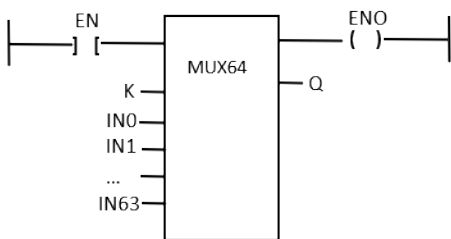

IL Language Example

Not available.

ST Language Example

```
Q := MUX64 (K, IN0, IN1, IN2, IN3, IN4, IN5, IN6, IN7, ..., IN63);
```

See Also

- "mux" (→ p. 234)
- "mux4" (→ p. 235)
- "mux8" (→ p. 237)
- "sel" (→ p. 240)

3.13.5 sel



 **Function** - Select one of the two integer inputs.

Inputs

Input	Data Type	Range	Unit	Default	Description
G	BOOL	FALSE, TRUE			Selection command.
IN0	ANY				First input.
IN1	ANY				Second input.

Outputs

Output	Data Type	Range	Unit	Description
Q	ANY			<ul style="list-style-type: none">• IN0 if G is FALSE• IN1 if G is TRUE

Remarks

None

Truth Table

G	Q
0	IN0
1	IN1

FBD Language Example

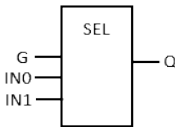

FFLD Language Example

- In the FFLD Language, the selector command is the input rung.
 - The output rung keeps the state of the input rung.
 - ENO has the same value as SELECT.

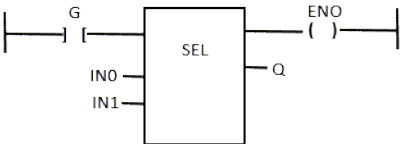

IL Language Example

- In the IL Language, the first parameter (selector) must be loaded in the current result before calling the function.
 - Other inputs are operands of the function, separated by comas.

```
Op1: LD  SELECT
      SEL IN1, IN2
      ST  Q
```

ST Language Example

```
Q := SEL (G, IN0, IN1);
```

See Also

- "mux" (→ p. 234)
- "mux4" (→ p. 235)
- "mux8" (→ p. 237)
- "mux64" (→ p. 238)

3.14 Standard Functions

PLCopen 

These are the standard functions:

Name	Description
CountOf	Returns the number of items in an array.
DEC	Decrease a numerical variable.
INC	Increase a numerical variable.
MoveBlock	Move / Copy items of an array.
NEG -	Performs a negation of the input. (unary operator)
NOT	Performs a Boolean negation of the input.

3.14.1 CountOf

PLCopen 



Function - Returns the number of items in an array.

Inputs

Input	Data Type	Range	Unit	Default	Description
ARR	Any				Declared array.

Outputs

Output	Data Type	Range	Unit	Description
Q	DINT			Total number of items in the array.

Remarks

- The input must be an array and can have any data type.
- This function is particularly useful to avoid writing directly the actual size of an array in a program.
 - This keeps the program independent from the declaration.

Example

```
FOR i := 1 TO CountOf (MyArray) DO
  MyArray[i-1] := 0;
END_FOR;
```

Examples

Array	Return
Arr1 [0..9]	10
Arr2 [0..4 , 0..9]	50

FBD Language Example



FFLD Language Example

- In the FFLD Language, the operation is executed only if the input rung (EN) is TRUE.
 - The output rung (ENO) keeps the same value as the input rung.
 - The function is executed only if EN is TRUE.

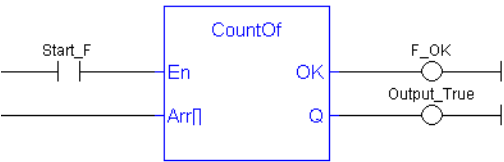

IL Language Example

Not available.

ST Language Example

```
Q := CountOf (ARR);
```

3.14.2 DEC



Function - Decrease a numerical variable.

Inputs

Input	Data Type	Range	Unit	Default	Description
IN	ANY				Numerical variable (increased after call).

Outputs

Output	Data Type	Range	Unit	Description
Q	ANY			Decreased value.

Remarks

- When the function is called, the variable connected to the IN input is decreased and copied to Q.
 - All data types are supported except BOOL and STRING.
 - For these types, the output is the copy of IN.
- For real values, a variable is decreased by 1.0.
- For time values, a variable is decreased by 1ms.
- The IN input must be directly connected to a variable.
 - It cannot be a constant or complex expression.

FBD Language Example



FFLD Language Example

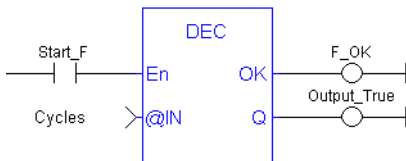

IL Language Example

Not available.

ST Language Example

- This function is particularly designed for the ST Language.
 - It allows simplified writing.
 - Assigning the result of the function is not mandatory.

```

IN := 2;
Q := DEC (IN);
(* now: IN = 1 ; Q = 1 *)
DEC (IN); (* simplified call *)
    
```

3.14.3 INC



 **Function** - Increase a numerical variable.

Inputs

Input	Data Type	Range	Unit	Default	Description
IN	ANY				Numerical variable (increased after call).

Outputs

Output	Data Type	Range	Unit	Description
Q	ANY			Increased value.

Remarks

- When the function is called, the variable connected to the IN input is decreased and copied to Q.
 - All data types are supported except BOOL and STRING.
 - For these types, the output is the copy of IN.
- For real values, a variable is decreased by 1.0.
- For time values, a variable is decreased by 1ms.
- The IN input must be directly connected to a variable.
 - It cannot be a constant or complex expression.

FBD Language Example



FFLD Language Example

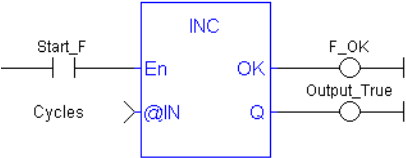

IL Language Example

Not available.

ST Language Example

- This function is particularly designed for the ST Language.
 - It allows simplified writing.
 - Assigning the result of the function is not mandatory.

```

IN := 1;
Q := INC (IN);
(* now: IN = 2 ; Q = 2 *)

```

```

INC (IN); (* simplified call *)

```

3.14.4 MoveBlock



Function - Move / Copy items of an array.

Inputs

Input	Data Type	Range	Unit	Default	Description
DST	ANY (*)				Array containing the destination of the copy.
NB	DINT				Number of items to be copied.
PosDST	DINT				Index of the destination in DST.
PosSRC	DINT				Index of the first character in SRC.
SRC	ANY (*)				Array containing the source of the copy.

(*) SRC and DST cannot be a STRING.

Outputs

Output	Data Type	Range	Unit	Description
OK	BOOL	FALSE, TRUE		TRUE if successful.

Remarks

- Arrays of string are not supported by this function.
- The function copies a number (NB) of consecutive items starting at the PosSRC index in SRC array to PosDST position in DST array.
 - SRC and DST can be the same array.
 - In this case, the function avoids lost items when source and destination areas overlap.
- This function verifies array bounds and is always safe.
 - The function returns TRUE if successful.
 - It returns FALSE if input positions and number do not fit the bounds of SRC and DST arrays.

FBD Language Example

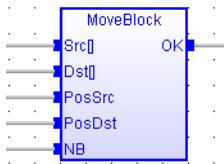

FFLD Language Example

- In the FFLD Language, the operation is executed only if the input rung (EN) is TRUE.

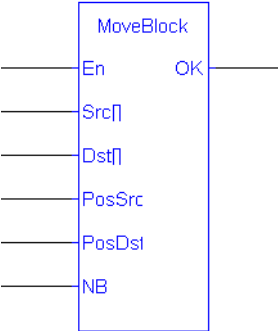

IL Language Example

Not available.

ST Language Example

```
OK := MOVEBLOCK (SRC, DST, PosSRS, PosDST, NB);
```

3.14.5 NEG -



Operator - Performs a negation of the input. (unary operator)

Inputs

Input	Data Type	Range	Unit	Default	Description
IN	ANY				Numeric value.

Outputs

Output	Data Type	Range	Unit	Description
Q	ANY			Negation of the input.

Remarks

- In FBD and FFLD language, the block **NEG** can be used.

Truth Table

IN	Q
0	0
1	-1
-123	123

FBD Language Example



FFLD Language Example

- In the FFLD Language, the conversion is executed only if the input rung (EN) is TRUE.
 - The output rung (ENO) keeps the same value as the input rung.
 - The negation is executed only if EN is TRUE.
 - ENO keeps the same value as EN.

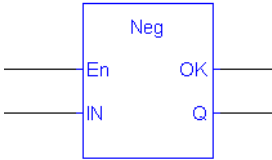

IL Language Example

Not available.

ST Language Example

- In the ST Language, - (hyphen) can be followed by a complex Boolean expression between parentheses.
 - The output data type must be the same as the input data type.

```
Q := -IN;
Q := - (IN1 + IN2);
```

3.14.6 NOT



Operator - Performs a Boolean negation of the input.

Inputs

Input	Data Type	Range	Unit	Default	Description
IN	BOOL	FALSE, TRUE			Boolean value.

Outputs

Output	Data Type	Range	Unit	Description
Q	BOOL	FALSE, TRUE		Boolean negation of the input.

Remarks

None

Truth Table

IN	Q
0	1
1	0

FBD Language Example

- In the FBD Language, the block "NOT" can be used.
 - Alternatively, you can use a link terminated by a "o" negation.

Example: Explicit use of the NOT block:



Example: Use of a negated link: Q is IN1 AND NOT IN2:



FFLD Language Example

- In the FFLD Language, negated contacts and coils can be used.

Example: Negated contact: Q is: IN1 AND NOT IN2:

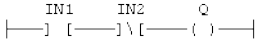

Example: Negated coil: Q is NOT (IN1 AND IN2):

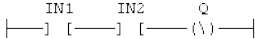

IL Language Example

- In the IL Language, the N modifier can be used with instructions FFLD, AND, OR, XOR and ST.
 - It represents a negation of the operand.

```
Op1: FFLDN IN1
      OR IN2
      ST Q (* Q is equal to: (NOT IN1) OR IN2 *)
Op2: FFLD IN1
      AND IN2
      STN Q (* Q is equal to: NOT (IN1 AND IN2) *)st
```

ST Language Example

- In the ST Language, NOT can be followed by a complex Boolean expression between parentheses.

```
Q := NOT IN;
Q := NOT (IN1 OR IN2);
```

See Also

- AND ANDN &
- OR / ORN
- XOR / XORN

3.15 String Operations

3.15.1 Character Strings

These operators and functions manage character strings:

Name	Operator / Function
ArrayToString / ArrayToStringU	Copies elements of a SINT array to a STRING.
ascii	Get the ASCII code of a character within a string.
ATOH	Converts a string to an integer using hexadecimal basis.
char	Builds a single character string.
concat	Concatenate of strings.
CRC16	Calculates a CRC16 on the characters of a string.
delete	Delete characters in a string.
find	Find the position of characters in a string.
HTOA	Converts an integer to a string using hexadecimal basis.
insert	Insert characters in a string.
left	Extract characters of a string on the left.
mid	Extract characters of a string at any position.
mlen	Get the number of characters in a string.
replace	Replace characters in a string.
right	Extract characters of a string on the right.
StringToArray / StringToArrayU	Copies the characters of a STRING to an array of SINT.

3.15.2 Manage String Tables

These functions manage string tables as resources:

Name	Description
LoadString	Loads a string from the active string table.
StringTable	Selects the active string table resource.

3.15.3 ArrayToString / ArrayToStringU

PLCopen 



Function - Copies elements of a SINT array to a STRING.

Inputs

Input	Data Type	Range	Unit	Default	Description
SRC	SINT[]		N/A	No default	Source array of SINT small integers. USINT for ArrayToStringU.
DST	STRING		N/A	No default	Destination STRING.
COUNT	DINT		N/A	No default	Number of characters to be copied.

Outputs

Output	Data Type	Range	Unit	Description
Q	DINT		N/A	Number of characters copied.

Remarks

- This function copies the COUNT first elements of the SRC array to the characters of the DST string.
- The function checks the maximum size of the destination string and adjusts the COUNT number if necessary.

FBD Language Example

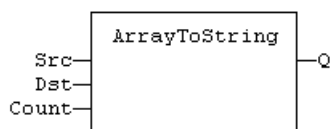

FFLD Language Example

- In the FFLD Language, the operation is executed only if the input rung (EN) is TRUE.
 - The output rung (ENO) keeps the same value as the input rung.

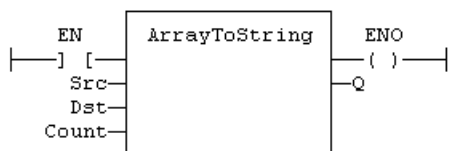

IL Language Example

Not available.

ST Language Example

```
Q := ArrayToString (SRC, DST, COUNT);
```

See Also

StringToArray / StringToArrayU

3.15.4 ascii



 **Function** - Get the ASCII code of a character within a string.

Inputs

Input	Data Type	Range	Unit	Default	Description
IN	STRING				Input string.
POS	DINT				Position of the character within the string. The first valid character position is 1.

Outputs

Output	Data Type	Range	Unit	Description
CODE	DINT			Either: <ul style="list-style-type: none"> The ASCII code of the selected character. 0 (zero) if the position is invalid.

Remarks

None

FBD Language Example

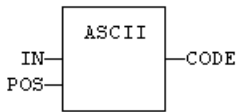

FFLD Language Example

- In the FFLD Language, the input rung (EN) enables the operation.
 - The output rung (ENO) keeps the same value as the input rung.

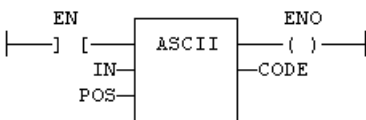

IL Language Example

- In the IL Language, the first parameter (IN) must be loaded in the current result before calling the function.
 - The other input is the operand of the function.

```
Op1: LD      IN
      AND_MASK MSK
      ST      CODE
```

ST Language Example

```
CODE := ASCII (IN, POS);
```

See Also

char

3.15.5 AToH

PLCopen 



Function - Converts a string to an integer using hexadecimal basis.

Inputs

Input	Data Type	Range	Unit	Default	Description
IN	STRING				String representing an integer in hexadecimal format.

Outputs

Output	Data Type	Range	Unit	Description
Q	DINT			Integer represented by the string.

Remarks

- This function is case insensitive.
- The result is 0 (zero) for an empty string.
- The conversion stops before the first invalid character.

Truth Table

IN	Q
' '	0
'12'	18
'a0'	160
'A0zzz'	160

FBD Language Example



FFLD Language Example

- In the FFLD Language, the operation is executed only if the input rung (EN) is TRUE.
 - The output rung (ENO) keeps the same value as the input rung.

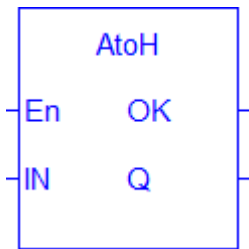

IL Language Example

- In the IL Language, the first input must be loaded before the function call.

```
Op1: LD IN
      ATOH
      ST Q
```

ST Language Example

```
Q := ATOH (IN);
```

See Also

HToA

3.15.6 char



Function - Builds a single character string.

Inputs

Input	Data Type	Range	Unit	Default	Description
CODE	DINT				ASCII code of the specified character.

Outputs

Output	Data Type	Range	Unit	Description
Q	STRING			STRING containing only the specified character.

Remarks

None

FBD Language Example

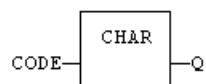

FFLD Language Example

- In the FFLD Language, the input rung (EN) enables the operation.
 - The output rung (ENO) keeps the same value as the input rung.

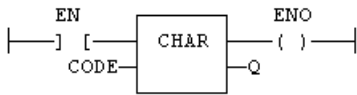

IL Language Example

- In the IL Language, the input parameter (CODE) must be loaded in the current result before calling the function.

```
Op1: LD   CODE
      CHAR
      ST   Q
```

ST Language Example

```
Q := CHAR (CODE);
```

See Also

ascii

3.15.7 concat

[PLCopen](#)



Function - Concatenate of strings.

Inputs

Input	Data Type	Range	Unit	Default	Description
IN_1	STRING				Any string variable or constant expression.
IN_N	STRING				Any string variable or constant expression.

Outputs

Output	Data Type	Range	Unit	Description
Q	STRING			Concatenation of all inputs.

Remarks

- In the FBD Language or FFLD Language, the block can have up to 16 inputs.
- In the IL Language or ST Language, the function accepts a variable number of inputs (at least 2).
- Use the + operator to concatenate strings.

FBD Language Example

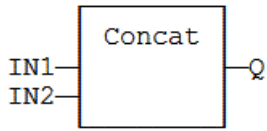

FFLD Language Example

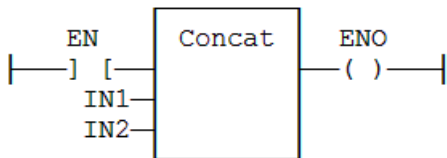

IL Language Example

```
Op1: FFLD      'AB'
      CONCAT 'CD', 'E'
      ST Q      (* Q is now 'ABCDE' *)
```

ST Language Example

```
Q := CONCAT ('AB', 'CD', 'E');
(* now Q is 'ABCDE' *)
```

3.15.8 CRC16



 **Function** - Calculates a CRC16 on the characters of a string.

Inputs

Input	Data Type	Range	Unit	Default	Description
IN	STRING				Character string.

Outputs

Output	Data Type	Range	Unit	Description
Q	INT			CRC16 calculated on all the characters of the string.

Remarks

- The function calculates a Modbus CRC16, initialized at 16#FFFF value.

FBD Language Example

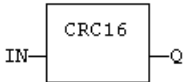

FPLD Language Example

- In the FPLD Language, the input rung (EN) enables the operation.
 - The output rung (ENO) keeps the same value as the input rung.
 - The function is executed only if EN is TRUE.

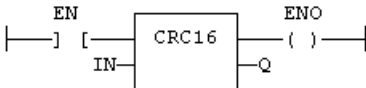

IL Language Example

- In the IL Language, the input must be loaded in the current result before calling the function.

```
Op1: LD    IN
      CRC16
      ST    Q
```

ST Language Example

```
Q := CRC16 (IN);
```

3.15.9 delete



Function - Delete characters in a string.

Inputs

Input	Data Type	Range	Unit	Default	Description
IN	STRING				Character string.
NBC	DINT				Number of characters to be deleted.
POS	DINT				Position of the first deleted character.

Outputs

Output	Data Type	Range	Unit	Description
Q	STRING			Modified string.

Remarks

- The first valid character position is 1.

FBD Language Example

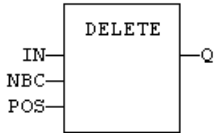

FFLD Language Example

- In the FFLD Language, the conversion is executed only if the input rung (EN) is TRUE.
 - The output rung (ENO) keeps the same value as the input rung.
 - The function is executed only if EN is TRUE.

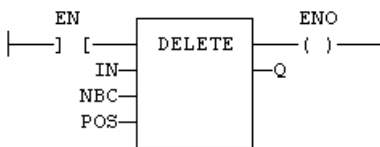

IL Language Example

- In the IL Language, the first input (the string) must be loaded in the current result before calling the function.
 - Other arguments are operands of the function, separated by commas.

```
Op1: LD      IN
      DELETE NBC, POS
      ST      Q
```

ST Language Example

```
Q := DELETE (IN, NBC, POS);
```

See Also

- Addition +
- find
- insert
- left
- mid
- mlen
- replace
- right

3.15.10 find



 **Function** - Find the position of characters in a string.

Inputs

Input	Data Type	Range	Unit	Default	Description
IN	STRING				Character string.
STR	STRING				Specific characters to search for within the STRING.

Outputs

Output	Data Type	Range	Unit	Description
POS	DINT			<ul style="list-style-type: none"> Position of the first character of STR in IN. Returns 0 (zero) if not found.

Remarks

- The first valid character position is 1.
- The search is case sensitive.
- The return value can be used with other string functions (e.g., "mid" (→ p. 265) or "right" (→ p. 269)).

FBD Language Example



FFLD Language Example

- In the FFLD Language, the operation is executed only if the input rung (EN) is TRUE.
 - The output rung (ENO) keeps the same value as the input rung.
 - The function is executed only if EN is TRUE.
 - ENO keeps the same value as EN.

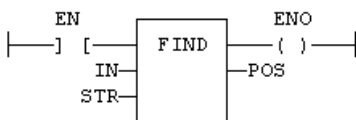

IL Language Example

- In the IL Language, the first input (the string) must be loaded in the current result before calling the function.
 - The second argument is the operand of the function.

```
Op1: LD      IN
      FIND   STR
      ST     POS
```

ST Language Example

```
POS := FIND (IN, STR);
```

See Also

- Addition +
- delete
- insert
- left
- mid
- mlen
- replace
- right

3.15.11 HToA

[PLCopen](#) ✓



Function - Converts and integer to a string using hexadecimal basis.

Inputs

Input	Data Type	Range	Unit	Default	Description
IN	DINT				Integer value.

Outputs

Output	Data Type	Range	Unit	Description
Q	STRING			String representing an integer in hexadecimal format.

Remarks

None

Truth Table

IN	Q
0	'0'
18	'12'
160	'A0'

FBD Language Example

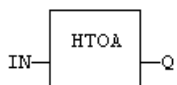

FFLD Language Example

- In the FFLD Language, the operation is executed only if the input rung (EN) is TRUE.
 - The output rung (ENO) keeps the same value as the input rung.
 - The function is executed only if EN is TRUE.
 - ENO keeps the same value as EN.

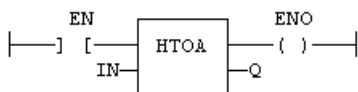

IL Language Example

- In the IL Language, the input must be loaded in the current result before calling the function.

```
Op1: LD  IN
      HTOA
      ST  Q
```

ST Language Example

```
Q := HTOA (IN);
```

See Also

AToH

3.15.12 insert

[PLCopen](#)



Function - Insert characters in a string.

Inputs

Input	Data Type	Range	Unit	Default	Description
IN	STRING				Character string.
STR	STRING				String containing characters to be inserted.
POS	DINT				Position of the first inserted character.

Outputs

Output	Data Type	Range	Unit	Description
Q	STRING			Modified string.

Remarks

The first valid character position is 1.

FBD Language Example

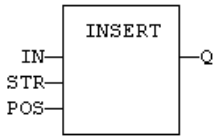

FFLD Language Example

- In the FFLD Language, the operation is executed only if the input rung (EN) is TRUE.
 - The output rung (ENO) keeps the same value as the input rung.
 - The function is executed only if EN is TRUE.
 - ENO keeps the same value as EN.

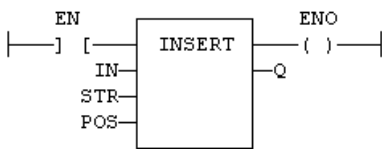

IL Language Example

- In the IL Language, the first input (the string) must be loaded in the current result before calling the function.
 - Other arguments are operands of the function, separated by comas.

```
Op1: LD      IN
      INSERT STR, POS
      ST      Q
```

ST Language Example

```
Q := INSERT (IN, STR, POS);
```

See Also

- Addition +
- delete
- find
- left
- mid
- mlen
- replace
- right

3.15.13 left



 **Function** - Extract characters of a string on the left.

Inputs

Input	Data Type	Range	Unit	Default	Description
IN	STRING				Character string.
NBC	DINT				Number of characters to extract.

Outputs

Output	Data Type	Range	Unit	Description
Q	STRING			String containing the first NBC characters of IN.

Remarks

None

FBD Language Example

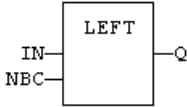

FFLD Language Example

- In the FFLD Language, the operation is executed only if the input rung (EN) is TRUE.
 - The output rung (ENO) keeps the same value as the input rung.
 - The function is executed only if EN is TRUE.
 - ENO keeps the same value as EN.

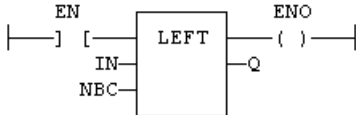

IL Language Example

- In the IL Language, the first input (the string) must be loaded in the current result before calling the function.
 - The second argument is the operand of the function.

```
Op1: LD      IN
      LEFT   NBC
      ST     Q
```

ST Language Example

```
Q := LEFT (IN, NBC);
```

See Also

- Addition +
- delete
- find
- insert
- mid
- mlen
- replace
- right

3.15.14 LoadString



Function - Loads a string from the active string table.

Inputs

Input	Data Type	Range	Unit	Default	Description
ID	DINT				ID of the string as declared in the string table.

Outputs

Output	Data Type	Range	Unit	Description
Q	STRING			Loaded string or empty string in case of error.

Remarks

- This function loads a string from the active string table and stores it in a STRING variable.
 - The "StringTable" (→ p. 270) function is used for selecting the active string table.
- The ID input (the string item identifier) is an identifier declared within the string table resource.
 - You don't need to define this identifier again - the system does it for you.

FBD Language Example

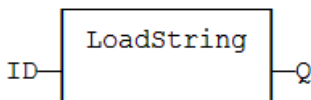

FFLD Language Example

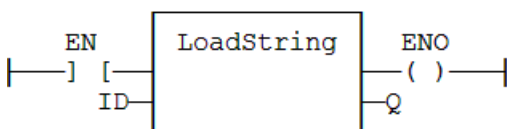

IL Language Example

```
Op1: LD      ID
      LoadString
      ST      Q
```

ST Language Example

```
Q := LoadString (ID);
```

See Also

StringTable

3.15.15 mid

PLCopen 



Function - Extract characters of a string at any position.

Inputs

Input	Data Type	Range	Unit	Default	Description
IN	STRING				Character string.
NBC	DINT				Number of characters to extract.
POS	DINT				Position of the first character to extract.

Outputs

Output	Data Type	Range	Unit	Description
Q	STRING			String containing the first NBC characters of IN.

Remarks

- The first valid character position is 1.

FBD Language Example

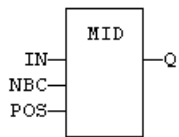

FFLD Language Example

- In the FFLD Language, the operation is executed only if the input rung (EN) is TRUE.
 - The output rung (ENO) keeps the same value as the input rung.
 - The function is executed only if EN is TRUE.
 - ENO keeps the same value as EN.

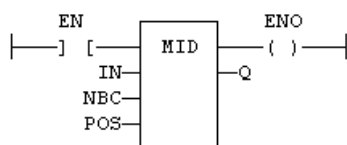

IL Language Example

- In the IL Language, the first input (the string) must be loaded in the current result before calling the function.
 - Other arguments are operands of the function, separated by comas.

```
Op1: LD   IN
      MID NBC, POS
      ST   Q
```

ST Language Example

```
Q := MID (IN, NBC, POS);
```

See Also

- Addition +
- delete
- find
- insert
- left
- mlen
- replace
- right

3.15.16 mlen

[PLCopen](#) 



Function - Get the number of characters in a string.

Inputs

Input	Data Type	Range	Unit	Default	Description
IN	STRING				Character string.

Outputs

Output	Data Type	Range	Unit	Description
NBC	DINT			Number of characters currently in the string. 0 (zero) if the string is empty.

Remarks

None

FBD Language Example

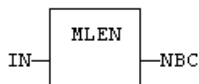

FFLD Language Example

- In the FFLD Language, the operation is executed only if the input rung (EN) is TRUE.
 - The output rung (ENO) keeps the same value as the input rung.
 - The function is executed only if EN is TRUE.
 - ENO keeps the same value as EN.

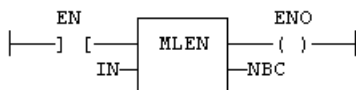

IL Language Example

In the IL Language, the input must be loaded in the current result before calling the function.

```
Op1: LD   IN
      MLEN
      ST   NBC
```

ST Language Example

```
NBC := MLEN (IN);
```

See Also

- Addition +
- delete
- find
- insert
- left
- mid
- replace
- right

3.15.17 replace

[PLCopen](#)



Function - Replace characters in a string.

Inputs

Input	Data Type	Range	Unit	Default	Description
IN	STRING				Character string.

Input	Data Type	Range	Unit	Default	Description
STR	STRING				String containing the characters to be inserted in place of the NDEL removed characters.
NDEL	DINT				Number of characters to be deleted before insertion of STR.
POS	DINT				Position where characters are replaced.

Outputs

Output	Data Type	Range	Unit	Description
Q	STRING			Modified string.

Remarks

- The first valid character position is 1.

FBD Language Example

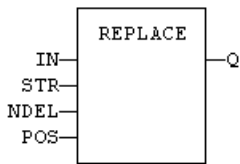

FFLD Language Example

- In the FFLD Language, the operation is executed only if the input rung (EN) is TRUE.
 - The output rung (ENO) keeps the same value as the input rung.
 - The function is executed only if EN is TRUE.
 - ENO keeps the same value as EN.

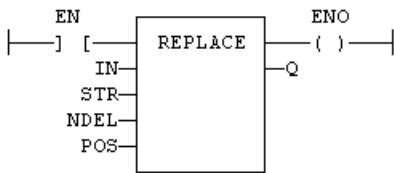

IL Language Example

- In the IL Language, the first input (the string) must be loaded in the current result before calling the function.
 - Other arguments are operands of the function, separated by comas.

```
Op1: LD      IN
      REPLACE STR, NDEL, POS
      ST      Q
```

ST Language Example

```
Q := REPLACE (IN, STR, NDEL, POS);
```

See Also

- "Addition +" (→ p. 82)
- "delete" (→ p. 257)
- "find" (→ p. 258)
- "insert" (→ p. 261)
- "left" (→ p. 262)
- "mid" (→ p. 265)
- "mlen" (→ p. 266)
- "right" (→ p. 269)

3.15.18 right



Function - Extract characters of a string on the right.

Inputs

Input	Data Type	Range	Unit	Default	Description
IN	STRING				Character string.
NBC	DINT				Number of characters to extract.

Outputs

Output	Data Type	Range	Unit	Description
Q	STRING			String containing the first NBC characters of IN.

Remarks

None

FBD Language Example

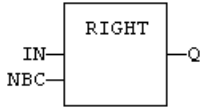

FFLD Language Example

- In the FFLD Language, the operation is executed only if the input rung (EN) is TRUE.
 - The output rung (ENO) keeps the same value as the input rung.
 - The function is executed only if EN is TRUE.
 - ENO keeps the same value as EN.

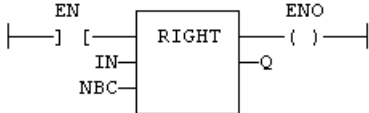

IL Language Example

- In the IL Language, the first input (the string) must be loaded in the current result before calling the function.
 - The second argument is the operand of the function.

```
Op1: LD      IN
      RIGHT  NBC
      ST      Q
```

ST Language Example

```
Q := RIGHT (IN, NBC);
```

See Also

- "delete" (→ p. 257)
- "find" (→ p. 258)
- "insert" (→ p. 261)
- "left" (→ p. 262)
- "mid" (→ p. 265)
- "mlen" (→ p. 266)
- "replace" (→ p. 267)

3.15.19 StringTable

[PLCopen](#) 



Function - Selects the active string table resource.

Inputs

Input	Data Type	Range	Unit	Default	Description
TABLE	STRING				Name of the Sting Table resource. Must be a constant.
COL	STRING				Name of the column in the table. Must be a constant.

Outputs

Output	Data Type	Range	Unit	Description
Q	BOOL	FALSE, TRUE		TRUE if OK.

Remarks

- This function selects a column of a valid String Table resource to become the active string table.
 - The "LoadString" (→ p. 264) function always refers to the active string table.

- Arguments must:
 - be constant string expressions.
 - fit to a declared string table and a valid column name within this table.
- If there is only one string table with only one column defined in the project, you do not need to call this function.
 - It is the default string table.

FBD Language Example

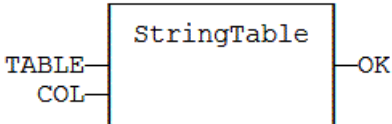

FFLD Language Example

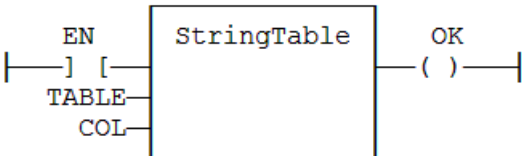

IL Language Example

```
Op1: LD
      'MyTable'
      StringTable 'First Column'
      ST
      OK
```

ST Language Example

```
OK := StringTable ('MyTable', 'FirstColumn');
```

See Also

- "LoadString" (→ p. 264)
- "String Table Resources" (→ p. 271)

3.15.19.1 String Table Resources

String tables are resources (embedded configuration data) edited with Workbench.

- A string table is a list of items identified by a name and referring to one or more character strings.
- String tables are typically used for defining static texts to be used in the application.
- These functions can be used for getting access to string tables in the programs:
 - "StringTable" (→ p. 270): selects the active string table.
 - "LoadString" (→ p. 264): Load a string from the active table.
- Each string table may contain several columns of texts for each item, and thus ease the localization of application, simply by defining a column for each language.
 - This way, the language can be selected dynamically at runtime by specifying the active language (as a column) in the StringTable() function.

The name entered in the string table as an ID is automatically declared for the compiler.

- The name:
 - Can directly be passed to the LoadString() function without re-declaring it.
 - Must conform to IEC standard naming rules.

You could do the same by declaring an array of `STRING` variables and enter some initial values for all items in the array.

- String tables provide significant advantages compared to arrays:
 - The editor provides a comfortable view of multiple columns at editing.
 - String tables are loaded in the application code and does not require any further RAM memory unlike declared arrays.
 - The string table editor automatically declares readable IDs for any string item to be used in programs instead of working with hard-coded index values.

TIP

If the text is too long for the `STRING` variable when used at runtime, it is truncated.
 Use special \$ sequences in strings to specify non printable characters, according to the IEC standard:

Code	Meaning
\$'	A Single quote.
\$\$	A "\$" character.
\$L	A line feed character (ASCII code 10).
\$N	Carriage return plus line feed characters (ASCII codes 13 and 10).
\$P	A page break character (ASCII code 12).
\$R	A carriage return character (ASCII code 13).
\$T	A tab stop (ASCII code 9).
\$xx	Any character (xx is the ASCII code expressed on two hexadecimal digits).

3.15.20 StringToArray / StringToArrayU



Function - Copies the characters of a `STRING` to an array of `SINT`.

Inputs

Input	Data Type	Range	Unit	Default	Description
SRC	STRING		N/A	No default	Source STRING.
DST	SINT		N/A	No default	Destination array of SINT small integers. USINT for StringToArrayU.

Outputs

Output	Data Type	Range	Unit	Description
Q	DINT		N/A	Number of characters copied.

Remarks

This function:

- Copies the characters of the SRC string to the first characters of the DST array.
- Checks the maximum size destination arrays and reduces the number of copied characters if necessary.

FBD Language Example

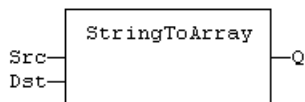

FFLD Language Example

- In the FFLD Language, the operation is executed only if the input rung (EN) is TRUE.
 - The output rung (ENO) keeps the same value as the input rung.

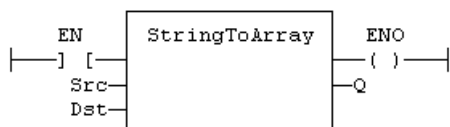

IL Language Example

- In the IL Language, the input must be loaded in the current result before calling the function.

```
Op1: LD
SRC
StringToArray DST
ST      Q
```

ST Language Example

```
Q := StringToArray (SRC, DST);
```

See Also

"ArrayToString / ArrayToStringU" (→ p. 250)

3.16 Timers

These are the functions for managing timers.

Name	Description
blink	Blinker.
BlinkA	Asymmetric blinker.
PLS	Pulse signal generator.
sig_gen	Generator of pseudo-analogical Signal.
TMD	Down-counting stop watch.
TMU / TMUsec	Up-counting stop watch (seconds).

Name	Description
TOF / TOFR	Off timer.
TON	On timer.
TP / TPR	Pulse timer.

3.16.1 blink



 **Function Block - Blinker.**

Inputs

Input	Data Type	Range	Unit	Default	Description
RUN	BOOL	FALSE, TRUE			Enabling command.
CYCLE	TIME				Blinking period.

Outputs

Output	Data Type	Range	Unit	Description
Q	BOOL	FALSE, TRUE		Output blinking signal.

Remarks

- The output signal is FALSE when the RUN input is FALSE.
- The CYCLE input is the complete period of the blinking signal.

Time Diagram

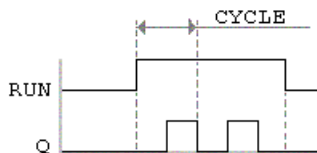

FBD Language Example

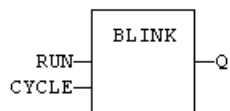

FFLD Language Example

- In the FFLD Language, the input rung is the IN command.
- The output rung is the Q output.



IL Language Example

```
(* MyBlinker is a declared instance of BLINK function block *)
Op1: CAL MyBlinker (RUN, CYCLE)
      FFLD MyBlinker.Q
      ST  Q
```

ST Language Example

```
(* MyBlinker is a declared instance of BLINK function block *)
MyBlinker (RUN, CYCLE);
Q := MyBlinker.Q;
```

See Also

- TOF / TOFR
- TON
- TP / TPR

3.16.2 BlinkA



 **Function Block** - Asymmetric blinker.

Inputs

Input	Data Type	Range	Unit	Default	Description
RUN	BOOL	FALSE, TRUE			Enabling command.
TM0	TIME				Duration of FALSE state on output.
TM1	TIME				Duration of TRUE state on output.

Outputs

Output	Data Type	Range	Unit	Description
Q	BOOL	FALSE, TRUE		Output blinking signal.

Remarks

- The output signal is FALSE when the RUN input is FALSE.

Time Diagram

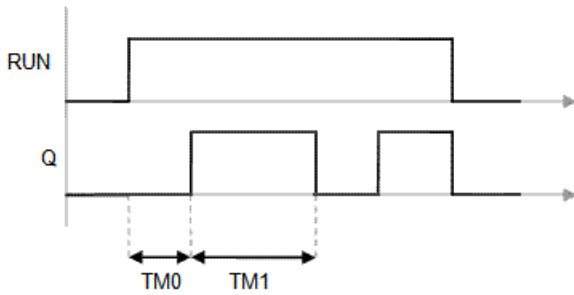

FBD Language Example

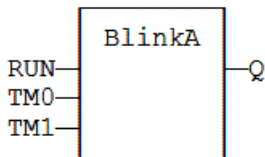

FFLD Language Example

- In the FFLD Language, the input rung is the IN command.
 - The output rung is the Q output.

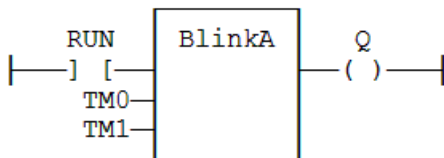

IL Language Example

```
(* MyBlinker is a declared instance of BLINKA function block *)
Op1: CAL MyBlinker (RUN, TM0, TM1)
      FFLD MyBlinker.Q
      ST Q
```

ST Language Example

```
(* MyBlinker is a declared instance of BLINKA function block. *)
MyBlinker (RUN, TM0, TM1);
Q := MyBlinker.Q;
```

See Also

- TOF / TOFR
- TON
- TP / TPR

3.16.3 PLS



 **Function Block** - Pulse signal generator.

Inputs

Input	Data Type	Range	Unit	Default	Description
RUN	BOOL	FALSE, TRUE			Enabling command.
CYCLE	TIME				Signal period.

Outputs

Output	Data Type	Range	Unit	Description
Q	BOOL	FALSE, TRUE		Output pulse signal.

Remarks

- On every period, the output is set to TRUE during one cycle only.

Time Diagram

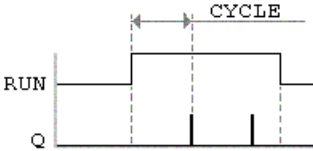

FBD Language Example

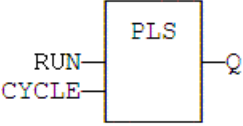

FFLD Language Example

- In the FFLD Language, the input rung is the IN command.
- The output rung is the Q output.

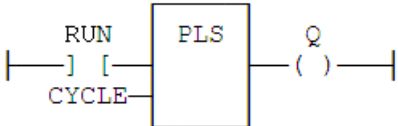

IL Language Example

```
(* MyPLS is a declared instance of PLS function block. *)
Op1: CAL MyPLS (RUN, CYCLE)
      FFLD MyPLS.Q
      ST
```

ST Language Example

```
(* MyPLS is a declared instance of PLS function block. *)
MyPLS (RUN, CYCLE);
Q := MyPLS.Q;
```

See Also

- TOF / TOFR
- TON
- TP / TPR

3.16.4 sig_gen

PLCopen 



Function Block - Generator of pseudo-analogical Signal.

Inputs

Input	Data Type	Range	Unit	Default	Description
Run	BOOL	FALSE, TRUE			Enabling command.
Period	TIME				Signal period.
Maximum	DINT				Maximum growth during the signal period.

Outputs

Output	Data Type	Range	Unit	Description
Pulse				Blinking at each period.
Up				Growing according to max * period.
End				Pulse after max * period.
Sine				Sine curve.

Remarks

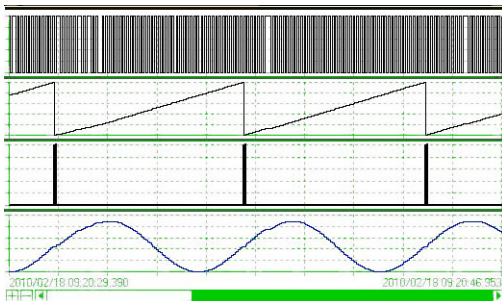

FBD Language Example

Not available.

FFLD Language Example

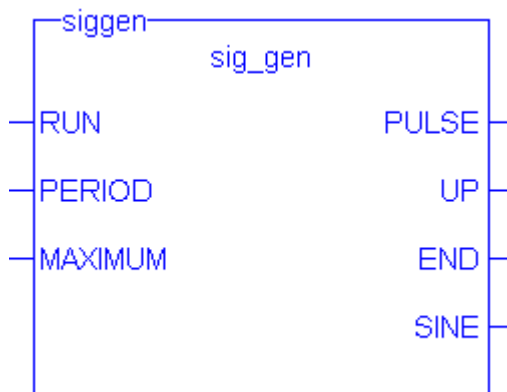

IL Language Example

Not available.

ST Language Example

Not available.

3.16.5 TMD

PLCopen 



Function Block - Down-counting stop watch.

Inputs

Input	Data Type	Range	Unit	Default	Description
IN	BOOL	FALSE, TRUE			The time counts when this input is TRUE.
RST	BOOL	FALSE, TRUE			Timer is reset to 0 (zero) when this input is TRUE.
PT	TIME				Programmed time.

Outputs

Input	Data Type	Range	Unit	Description
Q	BOOL	FALSE, TRUE		Timer elapsed output signal.
ET	TIME			Elapsed time.

Remarks

- The timer counts up when the IN input is TRUE.
 - It stops when the programmed time is elapsed.
- The timer is reset when the RST input is TRUE.
 - It is not reset when IN is false.

Time Diagram

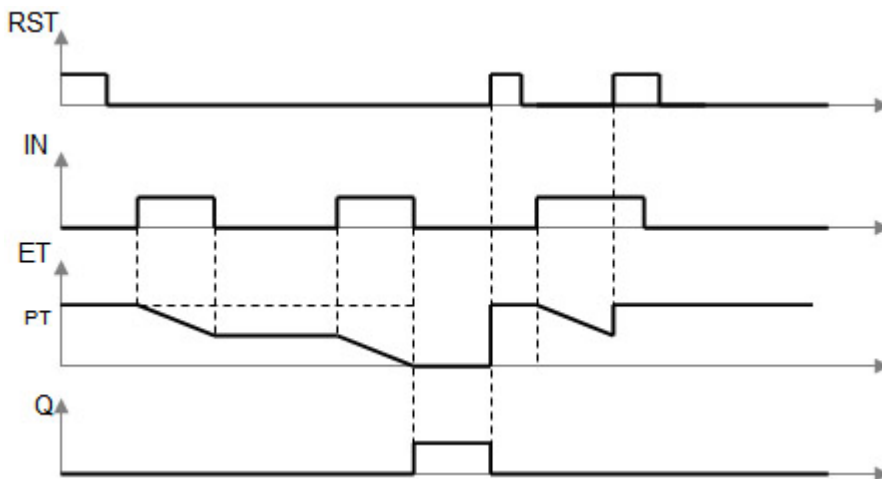
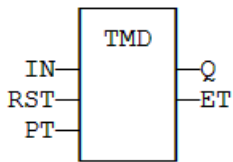
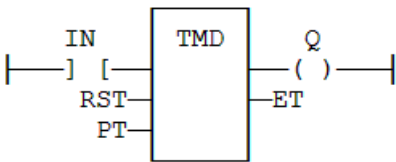

Figure 4-2: Time Diagram

FBD Language Example



FFLD Language Example



IL Language Example

```
(* MyTimer is a declared instance of TMD function block *)
Op1: CAL MyTimer (IN, RST, PT)
    FFLD: MyTimer.Q
    ST: Q
    FFLD: MyTimer.ET
    ST: ET
```

ST Language Example

```
(* MyTimer is a declared instance of TMD function block *)
MyTimer (IN, RST, PT);
Q := MyTimer.Q;
ET := MyTimer.ET;
```

See Also

"TMU / TMUsec" (→ p. 281)

3.16.6 TMU / TMUsec



Function Block - Up-counting stop watch (seconds).

Inputs

Input	Data Type	Range	Unit	Default	Description
IN	BOOL	FALSE, TRUE			The time counts when this input is TRUE.
RST	BOOL	FALSE, TRUE			Timer is reset to 0 (zero) when this input is TRUE.
PT	TIME				Programmed time. (TMU)
PTsec	UDINT				Programmed time. (TMUsec - seconds)

Outputs

Input	Data Type	Range	Unit	Description
Q	BOOL	FALSE, TRUE		Timer elapsed output signal.
ET	TIME			Elapsed time. (TMU)
ETsec	UDINT			Elapsed time. (TMU - seconds)

Remarks

TMUsec is identical to TMU except that the parameter is a number of seconds.

- The timer counts up when the IN input is TRUE.
 - It stops when the programmed time is elapsed.
- The timer is reset when the RST input is TRUE.
 - It is not reset when IN is false.

Time Diagram

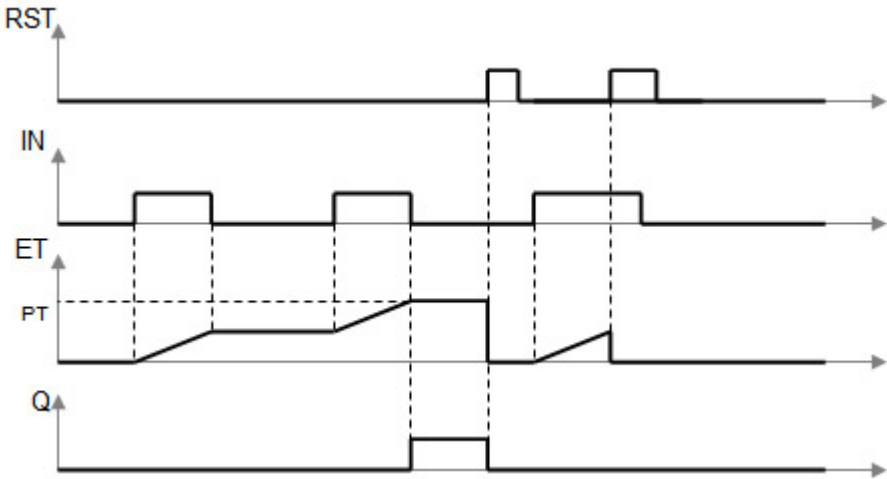
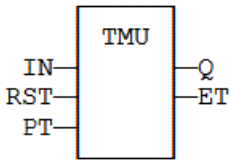
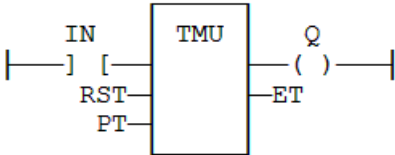

Figure 4-3: Time Diagram

FBD Language Example



FFLD Language Example



IL Language Example

```
(* MyTimer is a declared instance of TMU function block *)
Op1: CAL MyTimer (IN, RST, PT)
      FFLD MyTimer.Q
      ST Q
      FFLD MyTimer.ET
      ST ET
```

ST Language Example

```
(* MyTimer is a declared instance of TMU function block *)
MyTimer (IN, RST, PT);
Q := MyTimer.Q;
ET := MyTimer.ET;
```

See Also

"TMD" (→ p. 279)

3.16.7 TOF / TOFR



Function Block - Off timer.

Inputs

Input	Data Type	Range	Unit	Default	Description
IN	BOOL	FALSE, TRUE			Timer command.
PT	TIME				Programmed time.
RST	BOOL	FALSE, TRUE			Reset (TOFR only).

Outputs

Output	Data Type	Range	Unit	Description
Q	BOOL	FALSE, TRUE		Timer elapsed output signal.
ET	TIME			Elapsed time.

Remarks

- TOFR is same as TOF but has an extra input for resetting the timer.
- The timer starts on a falling pulse of IN input.
 - It stops when the elapsed time is equal to the programmed time.
- A rising pulse of IN input resets the timer to 0 (zero).
- The output signal is set to TRUE when the IN input rises to TRUE.
 - It is reset to FALSE when the programmed time is elapsed.

Time Diagram

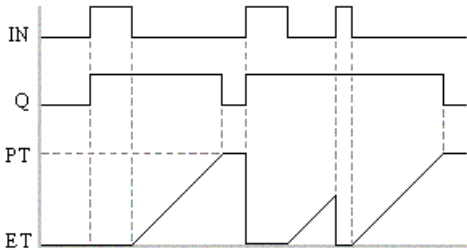
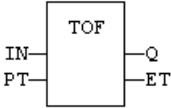

Figure 4-4: Time Diagram

FBD Language Example



FFLD Language Example

- In the FFLD Language, the input rung is the IN command.
 - The output rung is Q the output signal.

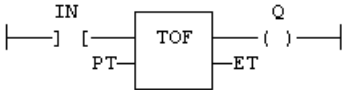

IL Language Example

```
(* MyTimer is a declared instance of TOF function block *)
Op1: CAL MyTimer (IN, PT)
      FFLD MyTimer.Q
      ST Q
      FFLD MyTimer.ET
      ST ET
```

ST Language Example

```
(* MyTimer is a declared instance of TOF function block *)
MyTimer (IN, PT);
Q := MyTimer.Q;
ET := MyTimer.ET;
```

See Also

- "blink" (→ p. 274)
- "TON" (→ p. 284)
- "TP / TPR" (→ p. 285)

3.16.8 TON



Function Block - On timer.

Inputs

Input	Data Type	Range	Unit	Default	Description
IN	BOOL	FALSE, TRUE			Timer command.
PT	TIME				Programmed time.

Outputs

Output	Data Type	Range	Unit	Description
Q	BOOL	FALSE, TRUE		Timer elapsed output signal.
ET	TIME			Elapsed time.

Remarks

- The timer starts on a rising pulse of IN input.
 - It stops when the elapsed time is equal to the programmed time.
- A falling pulse of IN input resets the timer to 0 (zero).
- The output signal is set to TRUE when programmed time is elapsed.
 - It is reset to FALSE when the input command falls.

Time Diagram

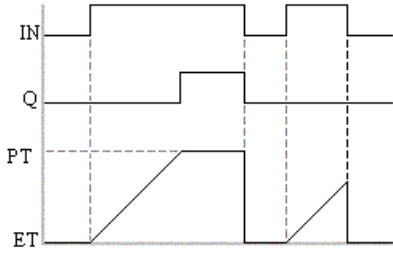
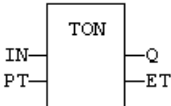

Figure 4-5: Time Diagram

FBD Language Example



FFLD Language Example

- In the FFLD Language, the input rung is the IN command.
- The output rung is Q the output signal.

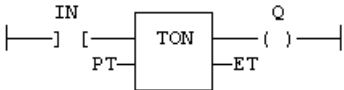

IL Language Example

```
(* MyTimer is a declared instance of TON function block *)
Op1: CAL MyTimer (IN, PT)
      FFLD MyTimer.Q
      ST Q
      FFLD MyTimer.ET
      ST ET
```

ST Language Example

```
MyTimer is a declared instance of TON function block.
MyTimer (IN, PT);
Q := MyTimer.Q;
ET := MyTimer.ET;
```

See Also

- "blink" (→ p. 274)
- "TOF / TOFR" (→ p. 282)
- "TP / TPR" (→ p. 285)

3.16.9 TP / TPR



 **Function Block - Pulse timer.**

Inputs

Input	Data Type	Range	Unit	Default	Description
IN	BOOL	FALSE, TRUE			Timer command.
PT	TIME				Programmed time.
RST	BOOL	FALSE, TRUE			Reset (TPR only).

Outputs

Output	Data Type	Range	Unit	Description
Q	BOOL	FALSE, TRUE		Timer elapsed output signal.
ET	TIME			Elapsed time.

Remarks

- TPR is same as TP but has an extra input for resetting the timer.
- The timer starts on a rising pulse of IN input.
 - It stops when the elapsed time is equal to the programmed time.
- A falling pulse of IN input resets the timer to 0 (zero) but only if the programmed time is elapsed.
- All pulses of IN while the timer is running are ignored.
- The output signal is set to TRUE while the timer is running.

Time Diagram

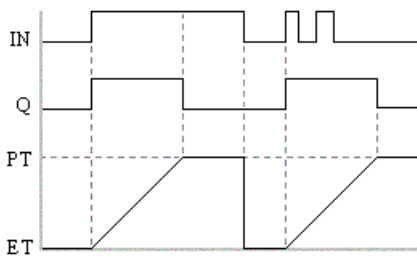
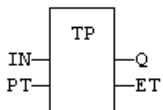

Figure 4-6: Time Diagram

FBD Language Example



FFLD Language Example

- In the FFLD Language, the input rung is the IN command.
 - The output rung is Q the output signal.

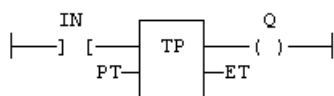

IL Language Example

```
(* MyTimer is a declared instance of TP function block *)
Op1: CAL MyTimer (IN, PT)
    FFLD MyTimer.Q
    ST Q
    FFLD MyTimer.ET
    ST ET
```

ST Language Example

```
(* MyTimer is a declared instance of TP function block *)
MyTimer (IN, PT);
Q := MyTimer.Q;
ET := MyTimer.ET;
```

See Also

- "blink" (→ p. 274)
- "TOF / TOFR" (→ p. 282)
- "TON" (→ p. 284)

3.17 Trigonometric Functions

These are the functions for trigonometric calculation:

Name	Description
acos / acosL	Calculate an arc-cosine.
asin / asinL	Calculate an arc-sine.
atan / atanL	Calculate an arc-tangent.
atan2 / atan2L	Calculate arc-tangent of Y/X.
cos / cosL	Calculate a cosine.
sin / sinL	Calculate a sine.
tan / tanL	Calculate a tangent.
UseDegrees	Sets the unit for angles in all trigonometric functions.

3.17.1 acos / acosL

 PLCopen ✓

 **Function** - Calculate an arc-cosine.

Inputs

Input	Data Type	Range	Unit	Default	Description
IN	REAL / LREAL				Real value.

Outputs

Output	Data Type	Range	Unit	Default	Description
Q	REAL / LREAL				Result: Arc-cosine of IN.

Remarks

None

FBD Language Example



FFLD Language Example

- In the FFLD Language, the operation is executed only if the input rung (EN) is TRUE.
 - The output rung (ENO) keeps the same value as the input rung.

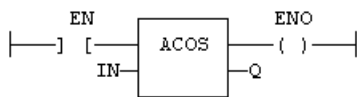

IL Language Example

- In the IL Language, the first input must be loaded before the function call.

```
Op1: LD IN
      ACOS
      ST Q    (* Q is: ACOS (IN) *)
```

ST Language Example

```
Q := ACOS (IN);
```

See Also

- asin / asinL
- atan / atanL
- atan2 / atan2L
- cos / cosL
- sin / sinL
- tan / tanL

3.17.2 asin / asinL



 **Function** - Calculate an arc-sine.

Inputs

Input	Data Type	Range	Unit	Default	Description
IN	REAL / LREAL				Real value.

Outputs

Output	Data Type	Range	Unit	Description
Q	REAL / LREAL			Result: Arc-sine of IN.

Remarks

None

FBD Language Example

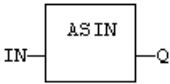

FFLD Language Example

- In the FFLD Language, the operation is executed only if the input rung (EN) is TRUE.
 - The output rung (ENO) keeps the same value as the input rung.

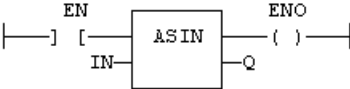

IL Language Example

- In the IL Language, the first input must be loaded before the function call.

```
Op1: LD IN
      ASIN
      ST Q (* Q is: ASIN (IN) *)
```

ST Language Example

```
Q := ASIN (IN);
```

See Also

- "acos / acosL" (→ p. 287)
- "atan / atanL" (→ p. 290)
- "atan2 / atan2L" (→ p. 291)

- "cos / cosL" (→ p. 292)
- "sin / sinL" (→ p. 293)
- "tan / tanL" (→ p. 294)

3.17.3 atan / atanL



 **Function** - Calculate an arc-tangent.

Inputs

Input	Data Type	Range	Unit	Default	Description
IN	REAL / LREAL				Real value.

Outputs

Output	Data Type	Range	Unit	Description
Q	REAL / LREAL			Result: Arc-tangent of IN.

Remarks

None

FBD Language Example

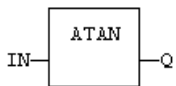

FFLD Language Example

- In the FFLD Language, the operation is executed only if the input rung (EN) is TRUE.
 - The output rung (ENO) keeps the same value as the input rung.
 - ENO keeps the same value as EN.

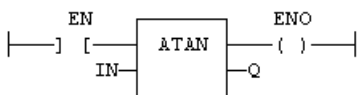

IL Language Example

- In the IL Language, the first input must be loaded before the function call.

```
Op1: LD IN
      ATAN
      ST Q      (* Q is: ATAN (IN) *)
```

ST Language Example

```
Q := ATAN (IN);
```

See Also

- acos / acosL
- asin / asinL
- atan2 / atan2L
- cos / cosL
- sin / sinL
- tan / tanL

3.17.4 atan2 / atan2L



Function - Calculate arc-tangent of Y/X.

Inputs

Input	Data Type	Range	Unit	Default	Description
X	REAL / LREAL				Real value.
Y	REAL / LREAL				Real value.

Outputs

Output	Data Type	Range	Unit	Description
Q	REAL / LREAL			Result: Arc-tangent of X / Y.

Remarks

None

FBD Language Example



FFLD Language Example

- In the FFLD Language, the operation is executed only if the input rung (EN) is TRUE.
 - The output rung (ENO) keeps the same value as the input rung.

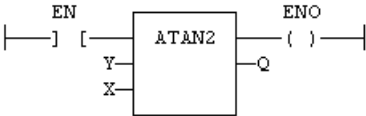

IL Language Example

- In the IL Language, the first input must be loaded before the function call.

```
Op1: LD Y
      ATAN2 X
      ST Q      (* Q is: ATAN2 (Y / X) *)
```

ST Language Example

Not available.

See Also

- acos / acosL
- asin / asinL
- 3.17.3 "atan / atanL"
- cos / cosL
- sin / sinL
- tan / tanL

3.17.5 cos / cosL



 Function - Calculate a cosine.

Inputs

Input	Data Type	Range	Unit	Default	Description
IN	REAL / LREAL				Real value.

Outputs

Output	Data Type	Range	Unit	Description
Q	REAL / LREAL			Result: Cosine of IN.

Remarks

None

FBD Language Example

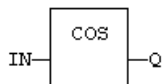

FFLD Language Example

- In the FFLD Language, the operation is executed only if the input rung (EN) is TRUE.
 - The output rung (ENO) keeps the same value as the input rung.
 - The function is executed only if EN is TRUE.

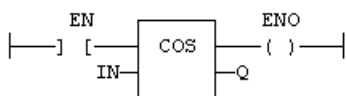

IL Language Example

- In the IL Language, the input must be loaded in the current result before calling the function.

```
Op1: LD  IN
      COS
      ST  Q      (* Q is: COS (IN) *)
```

ST Language Example

```
Q := COS (IN);
```

See Also

- acos / acosL
- asin / asinL
- atan / atanL
- atan2 / atan2L
- sin / sinL
- tan / tanL

3.17.6 sin / sinL

[PLCopen](#)



Function - Calculate a sine.

Inputs

Input	Data Type	Range	Unit	Default	Description
IN	REAL / LREAL				Real value.

Outputs

Output	Data Type	Range	Unit	Description
Q	REAL / LREAL			Result: Sine of IN.

Remarks

None

FBD Language Example

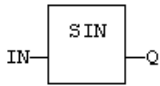

FFLD Language Example

- In the FFLD Language, the operation is executed only if the input rung (EN) is TRUE.
 - The output rung (ENO) keeps the same value as the input rung.
 - The function is executed only if EN is TRUE.
 - ENO keeps the same value as EN.

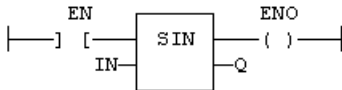

IL Language Example

- In the IL Language, the input must be loaded in the current result before calling the function.

```
Op1: LD IN
      SIN
      ST Q      (* Q is: SIN (IN) *)
```

ST Language Example

```
Q := SIN (IN);
```

See Also

- acos / acosL
- asin / asinL
- atan / atanL
- atan2 / atan2L
- cos / cosL
- tan / tanL

3.17.7 tan / tanL



 **Function** - Calculate a tangent.

3.17.7.1 Inputs

Input	Data Type	Range	Unit	Default	Description
IN	REAL / LREAL				Real value.

3.17.7.2 Outputs

Output	Data Type	Range	Unit	Description
Q	REAL / LREAL			Result: Tangent of IN.

Remarks

None

FBD Language Example

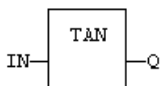

FFLD Language Example

- In the FFLD Language, the operation is executed only if the input rung (EN) is TRUE.
 - The output rung (ENO) keeps the same value as the input rung.
 - The function is executed only if EN is TRUE.
 - ENO keeps the same value as EN.

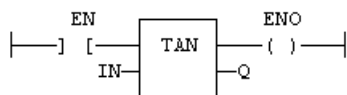

IL Language Example

Not available.

ST Language Example

```
Q := TAN (IN);
```

See Also

- acos / acosL
- asin / asinL
- atan / atanL
- atan2 / atan2L
- cos / cosL
- sin / sinL

3.17.8 UseDegrees

[PLCopen](#) ✓

 **Function** - Sets the unit for angles in all trigonometric functions.

Inputs

Input	Data Type	Range	Unit	Default	Description
IN	BOOL	FALSE, TRUE			<ul style="list-style-type: none"> • If TRUE, turn all trigonometric functions to use degrees. • If FALSE, turn all trigonometric functions to use radians (default).

Outputs

Output	Data Type	Range	Unit	Description
Q	BOOL	FALSE, TRUE		TRUE if functions use degrees before the call.

Remarks

This function sets the working unit for these functions:

Function	Description
"acos / acosL" (→ p. 287)	Calculate an arc-cosine.
"asin / asinL" (→ p. 288)	Calculate an arc-sine.
"atan / atanL" (→ p. 290)	Calculate an arc-tangent.
"atan2 / atan2L" (→ p. 291)	Calculate arc-tangent of Y/X.
"cos / cosL" (→ p. 292)	Calculate a cosine.
"sin / sinL" (→ p. 293)	Calculate a sine.
"tan / tanL" (→ p. 294)	Calculate a tangent.

FBD Language Example

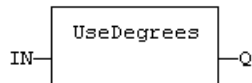

FFLD Language Example

- The first input is the rung.
- The rung is the output.

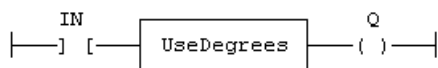

IL Language Example

Not available.

ST Language Example

```
Q := UseDegrees (IN);
```

Support and Services

About Kollmorgen

When you need motion and automation systems for your most demanding applications and environments, count on Kollmorgen - the innovation leader for more than 100 years. We deliver the industry's highest-performing, most reliable motors, drives, AGV control solutions and automation platforms, with over a million standard and easily modifiable products to meet virtually any motion challenge. We offer manufacturing facilities, distributors and engineering expertise in all major regions around the world, so you can bring a better machine to market faster and keep it profitable for many years to come.

Kollmorgen Developer Network



See the [Kollmorgen Support Network](#) for product support.
Search the knowledge base for answers and get product downloads.



Kollmorgen Support Locations

North America

Kollmorgen

201 West Rock Road
Radford, VA 24141, USA

Web: www.kollmorgen.com
Email: support@kollmorgen.com
Tel.: +1-540-633-3545
Fax: +1-540-639-4162

Europe

Kollmorgen Europe GmbH

Pempelfurtstr. 1
40880 Ratingen, Germany

Web: www.kollmorgen.com
Email: Technical.Support.EU@regalrexnord.com
Tel.: +49-2102-9394-0
Fax: +49-2102-9394-3155

South America

Altra Industrial Motion do Brasil

Equipamentos Industriais LTDA.
Avenida João Paulo Ablas, 2970
Jardim da Glória, Cotia – SP
CEP 06711-250, Brazil

Web: www.kollmorgen.com
Email: contato@kollmorgen.com
Tel.: (+55 11) 4615-6300

China and SEA

KOLLMORGEN

Room 302, Building 5, Libao Plaza,
88 Shenbin Road, Minhang District,
Shanghai, China.

Web: www.kollmorgen.cn
Email: sales.china@kollmorgen.com
Tel.: +86-400 668 2802