

AKD[®]2G-Sxx with Functional Safety Option 3

STO, SS1, SS2, SOS, SLA, SLI, SLP, SLS, SDI, SAR, SSR, SSM, SCA, SBC, SDB, SBT - SIL3, FSoE

Installation Manual, English



Manual Edition: E, February 2025

Safety Edition: S306, February 2025

Valid for AKD[®]2G-S Hardware Revision A

Part Number 907-200021-00

Original Document



For safe and proper use, follow these instructions.
Keep for future use.



KOLLMORGEN

A REGAL REKNORD BRAND

Record of Document Revisions

Edition	Remarks
...	Table with lifecycle information of this document (→ # 553)
A, 05/2021	First edition
B, 07/2022	SD Card text updated, Letter of Volatility link added, chapter "Shielding on drive" improved, Incr. Encoder feedback on X21 added, BiSS-C and SSI feedbacks on X41 (SFA) added, new motor connector image, chapter "Motion Bus interface" updated, PROFINET certified and available, chapter "Gearing" restructured, chapter "Feedback connector" restructured, SCCR rating for MV breaker changed, EtherNet/IP table updated, chapter "Mechanical Installation": Texts restructured and dimension table adapted, chapter "Mains supply": semi-conductor added, fusing chapter restructured, EAC approval removed, max. cable length per feedback type added, X23 feedback connector graphic expanded, conformity with UK added
C, 03/2024	7V24S drive contents added, including updated cover image, connector position image, general wiring diagrams, specifications and data, X3A and X3B connector content., individual X23 / X41 feedback wiring diagrams and specifications added, added connection to various mains supply network pages, limitations table edited, addition to part number scheme, corrected table formatting, added connector options availability table, added Projection of molten particles hazard warning, updated Safety Manual version compatibility table, updated AC and DC bus drive groupings to define number of axes limits, updated DIO X22 and X23 diagrams and bullets to better define termination and differential or single-ended options, updated 7V24S 24 A drives UL Approvals table to align with 65kA Certification, update EEO X22 diagrams.
D, 10/2024 (INTERNAL)	Removed content referring to DVD, new limitations for SMM1 and 2, new support page, wiring diagram corrected for drive test without load, addition to REACH and RoHS conformity
E, 02/2025	Note on mission time added to chapter "Disposal", removed content referring to DVD, new limitations for SMM1 and 2, new support page, wiring diagram corrected for drive test without load, addition to REACH and RoHS conformity

Hardware Revision (HR)

AKD2G	Firmware	WorkBench	KAS IDE	Remarks
A	from 02-00-00-000	from 2.00.0.0000	from 3.01	First revision

Trademarks

- Regal Rexnord and Kollmorgen are trademarks of Regal Rexnord Corporation or one of its affiliated companies.
- is a registered trademark of Kollmorgen Corporation.
- SafeMotion is a registered trademark of Kollmorgen Corporation.
- SMM is a registered trademark of Kollmorgen Corporation.
- EnDat is a registered trademark of Dr. Johannes Heidenhain GmbH.
- EtherCAT® and Safety over EtherCAT® are registered trademarks and patented technologies, licensed by Beckhoff Automation GmbH, Germany.
- EtherNet/IP is a registered trademark of ODVA, Inc.
- Modbus is a registered trademark of SCHNEIDER ELECTRIC USA, INC..
- HIPERFACE is a registered trademark of Max Stegmann GmbH.
- PROFINET is a registered trademark of PROFIBUS and PROFINET International (PI).
- Windows is a registered trademark of Microsoft Corporation.

Current patents

- US Patent 2017/0211640 (method and apparatus for power saving, fail-safe control of an electromechanical brake), patent pending
- US Patent 16,247,478 (method and apparatus for limiting the output voltages of switching mode power supplies), patent pending
- US Patent 8,154,228 (Dynamic Braking For Electric Motors)

- US Patent 8,214,063 (Auto-tune of a Control System Based on Frequency Response)
- US Patent 10.374.468 (System and method for improved DC power line communication)

Patents referring to fieldbus functions are listed in the matching fieldbus manual.

Technical changes which improve the performance of the device may be made without prior notice!

This document is the intellectual property of Kollmorgen. All rights reserved. No part of this work may be reproduced in any form (by photocopying, microfilm or any other method) or stored, processed, copied or distributed by electronic means without the written permission of Kollmorgen.

The information in this document is believed to be accurate and reliable at the time of its release. Kollmorgen assumes no responsibility for any damage or loss resulting from the use of this help, and expressly disclaims any liability or damages for loss of data, loss of use, and property damage of any kind, direct, incidental or consequential, in regard to or arising out of the performance or form of the materials presented herein or in any software programs that accompany this document.

Table of Contents

Table of Contents	4
1 General	18
1.1 About this Installation Manual	19
1.2 Symbols Used	19
1.2.1 Warning Symbols	19
1.2.2 Drawing Symbols	20
1.3 Abbreviations Used	21
2 Product Safety	22
2.1 You should pay attention to this	23
2.2 Use as Directed	25
2.3 Prohibited Use	25
2.4 Warning note labels	26
2.4.1 Notes placed on the product	26
2.4.2 Adhesive label in the package	26
2.5 Shock-hazard Protection	26
2.5.1 Leakage current	26
2.5.2 Residual current protective device (RCD)	26
2.5.3 Isolating transformers	27
2.6 Stop / Emergency Stop / Emergency Off	28
2.6.1 Stop	28
2.6.2 Emergency Stop	29
2.6.3 Emergency Off	29
3 Product life cycle handling	30
3.1 Transport	31
3.2 Packaging	31
3.3 Storage	31
3.4 Installation, setup and normal operation	31
3.5 Decommissioning	32
3.5.1 Volatile and Non-volatile Memory	32
3.6 Maintenance and Cleaning	32
3.6.1 Cleaning Procedure	32
3.7 Disassembly	32
3.8 System Repair	34
3.8.1 Exchange of the Controller	34
3.8.2 Exchange of Other Drive System Parts	34
3.9 Disposal	34
4 Package	36
4.1 Package Supplied	37
4.2 Nameplate	37
4.3 Part Number Scheme	37
4.3.0.1 Connector Options Availability	39
5 Technical description and data	40
5.1 The AKD2G Family of Digital Drives	41
5.2 Ambient Conditions, Ventilation and Mounting Position	43
5.3 Mechanical Data	43
5.4 Performance Data	43
5.5 Electrical data	44
5.5.1 Single axis variants (S)	44
5.5.1.1 Mains supply data, 1 phase AC, type AKD2G-Sxx- (S)	44
5.5.1.2 Mains supply data, 3 phase AC, type AKD2G-Sxx- (S)	44
5.5.1.3 Mains supply data, DC, type AKD2G-Sxx- (S)	45
5.5.1.4 Output data, type AKD2G-Sxx- (S)	46

5.5.2 Dual axis variants (D: I1=I2)	47
5.5.2.1 Mains supply data, 1 phase AC, type AKD2G-Sxx- (D)	47
5.5.2.2 Mains supply data, 3 phase AC, type AKD2G-Sxx- (D)	47
5.5.2.3 Mains supply data, DC, type AKD2G-Sxx- (D)	47
5.5.2.4 Output data, type AKD2G-Sxx- (D)	48
5.5.3 Steady State Control Current per Brake Option	49
5.6 Electrical Motor Braking	49
5.6.1 Drive dynamic braking	49
5.6.2 Regeneration braking	49
5.6.2.1 Functional description	49
5.6.2.2 Technical data AKD2G-Sxx-6V	50
5.6.2.3 Technical data for AKD2G-Sxx-7V	50
5.7 LCD Display and Push-buttons (B1, B2)	51
5.8 Rotary Switches (S1, S2)	54
5.9 SD Card Slot	55
6 Mechanical Installation	56
6.1 Important Notes	57
6.2 Guide to Mechanical Installation	57
6.3 Dimensions	57
7 Electrical Installation	60
7.1 Important Notes	61
7.2 Guide to electrical installation	62
7.3 Wiring	63
7.3.1 General	63
7.3.2 Mating connectors	63
7.3.3 Cable and Wire Requirements	64
7.3.3.1 Cable material	64
7.3.3.2 Cable length	64
7.3.3.3 T-Connector wiring	64
7.3.3.4 Cable cross sections and requirements	65
7.3.4 Protective Earth Connection	66
7.4 EMI Noise Reduction	66
7.4.1 Reducing EMI noise	66
7.4.2 Shielding with external shielding busbar	67
7.4.2.1 Shielding Concept	67
7.4.2.2 Shielding Busbar	68
7.4.3 Shielding connection to the drive	69
7.4.3.1 Shielding Concept	69
7.4.3.2 Grounding plates and shield connection clamps	71
7.4.3.3 Motor connector X1/X2 with shielding connection	71
7.5 Connection Overview	71
7.5.1 Connector Position AKD2G-Sxx-6VxxS	71
7.5.2 Connector Position AKD2G-Sxx-7VxxS	73
7.5.2.1 AKD2G 480 Vac, 3 to 12 Amp drives	73
7.5.2.2 AKD2G 480 Vac, 24 Amp drive	74
7.5.3 Connector Position AKD2G-Sxx-6VxxD	75
7.5.4 Connector Position AKD2G-Sxx-7VxxD	76
7.5.5 Wiring overview, single axis drive	77
AKD2G Sxx-xxS 3-12 Amp Drives	77
AKD2G Sxx-724S 24 Amp Drives	78
7.5.6 Wiring overview, dual axis drive	79
AKD2G Sxx-xxD 3-12 Amp Drives	79
7.5.7 Connector pinout	79
7.5.7.1 X1 and X2: Motor, Brake, Feedback 1	80

7.5.7.2	X3: Mains, regen resistor, DC-Bus	81
7.5.7.3	X3A/X3B: Mains, regen resistor, DC-Bus	82
7.5.7.4	X4: Second Brake	83
7.5.7.5	X5: Feedback 2	83
7.5.7.6	X10: 24 VDC	83
7.5.7.7	X11, X12: EtherNet Fieldbus	84
7.5.7.8	X13, X14: CAN bus (optional)	84
7.5.7.9	X20: Service	84
7.5.7.10	X21: I/O, Feedback 4	85
7.5.7.11	X22: I/O, EEO2, Feedback 5	86
7.5.7.12	X23: I/O, EEO1, Feedback 3	87
7.5.7.13	X41: SFA Feedback converter, EEO3/EEO4 EXX3/EXX4 (accessory)	88
7.6	Power and Logic Voltage Supply (X3/X10)	89
7.6.1	Electrical Supply Connection	89
7.6.1.1	Connection to various mains supply networks AKD2G-Sxx-6V (100V to 240V)	89
7.6.1.2	Connection to various mains supply networks AKD2G-Sxx-7V (240V to 480V)	90
7.6.2	Mains power supply connector X3/X3A	91
7.6.2.1	Wiring examples mains power supply	92
7.6.2.2	Fusing	97
7.6.3	Auxiliary voltage power supply connector X10	102
7.6.3.1	Fusing	103
7.6.3.2	Wiring example 24 VDC supply	103
7.7	DC Bus link connector X3/X3B	103
7.7.1	Fusing	105
7.7.2	Wiring example with T connectors	105
7.7.3	Wiring example with busbar	106
7.8	Regen resistor connector X3/X3B	106
7.8.1	Fusing and Wiring	106
7.9	Motor Power, Brake and Feedback connection	107
7.9.1	Motor connectivity, some examples	107
7.9.2	Single motor cable connection	108
7.9.2.1	Motor Power, Brake and Feedback connectors X1, X2	108
7.9.2.2	Feedback connectors X5, X41, X21, X22, X23	110
7.9.2.3	Secondary Brake connector X4	110
7.9.3	Dual motor cable connection	110
7.9.3.1	Motor power and motor brake connectors X1, X2	112
7.9.3.2	Feedback connectors X1, X2, X5, X41, X21, X22, X23	112
7.9.3.3	Secondary Brake connector X4	113
7.9.4	Motor Holding Brake Connection	113
7.9.4.1	Secondary Brake connector X4	115
7.10	Feedback Connection	116
7.10.1	Overview	116
7.10.2	Feedback to Connector	116
7.10.3	Feedback Type to Connector	116
7.10.4	Maximum Cable Lengths by Feedback Type	117
7.10.5	Feedback Connectors X1, X2	118
7.10.6	Feedback Connector X5	119
7.10.7	Feedback Connector X21	120
7.10.8	Feedback Connector X22	121
7.10.9	Feedback Connector X23	122
7.10.9.1	X23 Connector Pinout Summary	122
7.10.10	X23 Feedback Wiring Pinout Diagrams	124
7.10.10.1	X23 SFD Feedback	124
7.10.10.2	X23 Resolver Feedback	125

7.10.10.3	X23 BiSS (Mode B) Analog Feedback	126
7.10.10.4	X23 BiSS (Mode C) Digital Feedback	127
7.10.10.5	X23 EnDAT 2.1 Feedback (with 1V p-p analog signals)	128
7.10.10.6	X23 EnDAT 2.2 Digital Feedback	129
7.10.10.7	X23 HIPERFACE Feedback	130
7.10.10.8	X23 Sine Encoder Feedback	131
7.10.10.9	X23 Sine Encoder with Hall Feedback	132
7.10.10.10	X23 Incremental Encoder Feedback	133
7.10.10.11	X23 Incremental Encoder with Hall Feedback	134
7.10.10.12	X23 Hall Feedback	135
7.10.10.13	X23 SSI Feedback	135
7.10.10.14	X23 Step / Direction and CW / CCW Feedback	136
7.10.11	Feedback Connector X41 (SFA, accessory)	137
7.10.11.1	X41 Connector Pinout Summary	138
7.10.12	X41 Feedback Wiring Pinout Diagrams	139
7.10.12.1	X41 SFD Feedback	139
7.10.12.2	X41 Resolver Feedback	140
7.10.12.3	X41 BiSS (Mode B) Analog Feedback	141
7.10.12.4	X41 BiSS (Mode C) Digital Feedback	142
7.10.12.5	X41 EnDAT 2.1 Feedback (with 1 V p-p analog signals)	143
7.10.12.6	X41 EnDAT 2.2 Digital Feedback	144
7.10.12.7	X41 HIPERFACE Feedback	145
7.10.12.8	X41 Sine Encoder Feedback	146
7.10.12.9	X41 Sine Encoder with Hall Feedback	147
7.10.12.10	X41 Incremental Encoder Feedback	148
7.10.12.11	X41 Incremental Encoder with Hall Feedback	149
7.10.12.12	X41 Hall Feedback	150
7.10.12.13	X41 SSI Feedback	150
7.11	Gearing	151
7.11.1	Overview	151
7.11.2	Input - Electronic Gearing	151
7.11.3	Output - Emulated Encoder Output (EEO)	151
7.11.4	Master-Slave control	153
7.11.4.1	Examples	153
7.12	Ethernet Fieldbus Interface Connector X11/X12	155
7.12.1	EtherCAT® and Safety over EtherCAT®	155
7.12.2	PROFINET	156
7.12.3	EtherNet/IP	157
7.13	CAN-Bus Interface connector X13/X14	158
7.13.1	CAN-Bus Topology	158
7.13.2	CAN-Bus Wiring	159
7.13.3	Baud rate for CAN-Bus	160
7.13.4	Node Address for CAN-Bus	160
7.13.5	CAN-Bus Termination	160
7.14	Service Interface connector X20	160
7.14.1	Possible Network Configurations	161
7.15	Modbus TCP connector X20	162
7.16	I/O Connectors X21/X22/X23	162
7.16.1	Technical data	163
7.16.2	Analog Input	164
7.16.3	Analog Output	166
7.16.4	Digital Inputs	166
7.16.4.1	Digital-In 1 and 2	167
7.16.4.2	Digital-In 3 to 12	168

7.16.4.3	Digital-In/Out 1 and 2	169
7.16.4.4	Digital-In/Out 3 to 6	170
7.16.5	Digital Outputs	171
7.16.5.1	Digital-Out 5 to 6	171
7.16.5.2	Digital-Out 7 and 8	172
7.16.5.3	Digital-In/Out 1 and 2	173
7.16.5.4	Digital-In/Out 3 to 6	174
7.16.5.5	Digital-Out 9, Relay contacts	175
8	Setup	176
8.1	Important Notes	177
8.2	Guide to drive setup	178
8.2.1	Initial Drive Test Procedure	178
8.2.1.1	Unpacking, mounting, and wiring the AKD2G	178
8.2.1.2	Minimum wiring for drive test without load, example	178
8.2.1.3	Confirm connections (example: directly to PC)	179
8.2.1.4	System integration	179
8.2.1.5	Install and start WorkBench	180
8.2.1.6	Setup the axis in WorkBench	180
8.2.1.7	Enable the axis (Hardware)	180
8.2.1.8	Move the motor axis	180
8.2.1.9	Tune the axis	180
8.2.2	WorkBench Installation	181
8.2.2.1	Use as directed	181
8.2.2.2	Software description	182
8.2.2.3	Hardware requirements	182
8.2.2.4	Operating systems	182
8.2.2.5	Installation under Windows 7/8/10/11	183
8.3	Switch-On and Switch-Off Behavior	183
8.3.1	Switch-on behavior in standard operation	184
8.3.2	Switch-off behavior	186
8.3.2.1	Switch-off behavior using the AXIS#.DIS command	186
8.3.2.2	Switch-off behavior using a digital input (controlled stop)	187
8.3.2.3	Switch-off behavior using STO input (uncontrolled stop)	187
8.3.2.4	Switch-off behavior in the event of a fault	188
8.4	Fault and Warning Messages	191
8.4.1	Fault and warning messages AKD2G	191
8.5	Troubleshooting	192
9	Safety Manual for FS3	193
9.1	General Notes	195
9.1.1	Use as directed	196
9.1.2	Prohibited use	196
9.1.3	Abbreviations used for functional safety	197
9.1.4	Enclosure, wiring	198
9.2	Updating the SMM Firmware	199
9.3	Commissioning	201
9.3.1	First time commissioning	201
9.3.2	Recommissioning	202
9.3.3	Diagnostic Testing of safe inputs, safe outputs and STO	202
9.3.4	Diagnostic Testing of safe brake control	202
9.4	Safety Functions Option 3 (FSoE, SIL3 PLe)	203
9.4.1	Safety Properties Overview	203
9.4.1.1	Activation by FSoE	204
9.4.1.2	Activation by Safety Functions	204
9.4.1.3	Activation By Safe Digital Inputs	205

9.4.1.4	Safety Function Response Time Calculation	209
9.4.2	Technical Data	210
9.4.2.1	Safe Digital Inputs	210
9.4.2.2	Safe Digital Outputs	211
9.4.2.3	Factory Defaults without FSoE	211
9.4.2.4	OSSD	212
9.4.2.5	FSoE	213
9.4.2.6	Motor Brake Requirements	215
9.4.2.7	Motor feedback requirements	216
9.4.3	STO (Safe Torque Off)	219
9.4.3.1	Description	219
9.4.3.2	Activation	220
9.4.3.3	Restart	220
9.4.3.4	Timing	221
9.4.3.5	Related Parameters	221
9.4.3.6	Setup in WorkBench	223
9.4.3.7	Fault Reaction/ Failure Messages	223
9.4.3.8	Safety Diagnostic for the Safe I/O view in WorkBench	223
9.4.3.9	Safety Properties	223
9.4.4	SS1-t (Safe Stop 1)	223
9.4.4.1	Description	224
9.4.4.2	Activation	224
9.4.4.3	Safety Properties	224
9.4.4.4	Restart	225
9.4.4.5	Timing	225
9.4.4.6	Related Parameters	226
9.4.4.7	Setup in WorkBench	227
9.4.4.8	Fault Reaction / Failure Messages	227
9.4.4.9	Safety State / Status Signals	227
9.4.5	SS1-r (Safe Stop 1)	228
9.4.5.1	Description	228
9.4.5.2	Activation	228
9.4.5.3	Safety Properties	229
9.4.5.4	Restart	229
9.4.5.5	Timing	229
9.4.5.6	Related Parameters	230
9.4.5.7	Setup in WorkBench	231
9.4.5.8	Fault Reaction / Failure Message	231
9.4.5.9	Safety State / Status Signals	231
9.4.6	SS2 (Safe Stop 2)	232
9.4.6.1	Description	232
9.4.6.2	Activation	233
9.4.6.3	Safety Properties	233
9.4.6.4	Timing	233
9.4.6.5	Related Parameters	234
9.4.6.6	Setup in WorkBench	234
9.4.6.7	Fault Reaction / Failure Messages	235
9.4.6.8	Safety State / Status Signals	235
9.4.7	SOS (Safe Operating Stop)	236
9.4.7.1	Description	236
9.4.7.2	Activation	237
9.4.7.3	Restart	237
9.4.7.4	Related Parameters	237

9.4.7.5	Timing	238
9.4.7.6	Setup in WorkBench	239
9.4.7.7	Fault Reaction / Failure Messages	239
9.4.7.8	Safety State / Status Signals	239
9.4.7.9	Safety Properties	239
9.4.8	SBC (Safe Brake Control)	240
9.4.8.1	Description	240
9.4.8.2	Test Pulses	241
9.4.8.3	Activation	241
9.4.8.4	Restart	242
9.4.8.5	SBC Muting Function	243
9.4.8.6	Timing: SS1 followed by SBC without SDB	245
9.4.8.7	Timing: SS1 followed by SBC with SDB	246
9.4.8.8	Setup in WorkBench	247
9.4.8.9	Fault Reaction / Failure Messages	248
9.4.8.10	Safety State / Status Signals	248
9.4.8.11	Safety Properties	248
9.4.9	SBT (Safe Brake Test)	249
9.4.9.1	Description	249
9.4.9.2	Activation	251
9.4.9.3	Related Parameters	251
9.4.9.4	Timing	252
9.4.9.5	Setup in WorkBench	253
9.4.9.6	Fault Reaction / Failure Messages	253
9.4.9.7	Safety State / Status Signals	254
9.4.10	SDB (Safe Dynamic Brake)	255
9.4.10.1	Description	255
9.4.10.2	Activation	256
9.4.10.3	Restart	257
9.4.10.4	Timing	257
9.4.10.5	Related Parameters	258
9.4.10.6	Setup in WorkBench	258
9.4.10.7	Fault Reaction / Failure Messages	258
9.4.10.8	Safety State / Status Signals	260
9.4.10.9	Safety Properties	260
9.4.11	SLS (Safely Limited Speed)	261
9.4.11.1	Description	261
9.4.11.2	Activation	261
9.4.11.3	Timing	262
9.4.11.4	Related Parameters	262
9.4.11.5	Setup in WorkBench	263
9.4.11.6	Fault Reaction / Failure Messages	263
9.4.11.7	Safety State / Status Signals	263
9.4.11.8	Safety Properties	263
9.4.12	SSM (Safe Speed Monitor)	264
9.4.12.1	Description	264
9.4.12.2	Activation	264
9.4.12.3	Related Parameters	264
9.4.12.4	Timing	265
9.4.12.5	Setup in WorkBench	265
9.4.12.6	Safety State / Status Signals	265
9.4.12.7	Safety Properties	265
9.4.13	SSR (Safe Speed Range)	266
9.4.13.1	Description	266

9.4.13.2	Activation	266
9.4.13.3	Timing	267
9.4.13.4	Related Parameters	267
9.4.13.5	Setup in WorkBench	268
9.4.13.6	Fault Reaction / Failure Messages	268
9.4.13.7	Safety State / Status Signals	268
9.4.13.8	Safety Properties	268
9.4.14	SDI (Safe Direction)	269
9.4.14.1	Description	269
9.4.14.2	Activation	270
9.4.14.3	Timing	270
9.4.14.4	Related Parameters	271
9.4.14.5	Setup in WorkBench	271
9.4.14.6	Fault Reaction / Failure Messages	272
9.4.14.7	Safety State / Status Signals	272
9.4.14.8	Safety Properties	272
9.4.15	SLA (Safely Limited Acceleration)	273
9.4.15.1	Description	273
9.4.15.2	Activation	273
9.4.15.3	Timing	274
9.4.15.4	Related Parameters	274
9.4.15.5	Setup in WorkBench	275
9.4.15.6	Fault Reaction / Failure Messages	275
9.4.15.7	Safety State / Status Signals	275
9.4.15.8	Safety Properties	275
9.4.16	SAR (Safe Acceleration Range)	276
9.4.16.1	Description	276
9.4.16.2	Activation	276
9.4.16.3	Timing	277
9.4.16.4	Related Parameters	278
9.4.16.5	Setup in WorkBench	278
9.4.16.6	Fault Reaction / Failure Messages	278
9.4.16.7	Safety State / Status signals	278
9.4.16.8	Safety Properties	279
9.4.17	SLI (Safely Limited Increment)	280
9.4.17.1	Description	280
9.4.17.2	Activation	280
9.4.17.3	Timing	281
9.4.17.4	Related Parameters	281
9.4.17.5	Setup in WorkBench	282
9.4.17.6	Fault Reaction / Failure Messages	282
9.4.17.7	Safety State / Status Signals	282
9.4.17.8	Safety Properties	282
9.4.18	SLP (Safely Limited Position)	283
9.4.18.1	Description	283
9.4.18.2	Activation	283
9.4.18.3	Timing	284
9.4.18.4	Related Parameters	284
9.4.18.5	Setup in WorkBench	285
9.4.18.6	Fault Reaction / Failure Messages	285
9.4.18.7	Safety State / Status Signals	285
9.4.18.8	Safety Properties	285
9.4.19	SCA (Safe Cam)	286
9.4.19.1	Description	286

9.4.19.2	Activation	286
9.4.19.3	Related Parameters	286
9.4.19.4	Timing	287
9.4.19.5	Setup in WorkBench	287
9.4.19.6	Safety State / Status Signals	287
9.4.19.7	Safety Properties	287
9.5	Settings	288
9.5.1	Display, Push-Buttons and Rotary Switches	288
9.5.2	Default Safety Parameters	289
9.5.3	SafelD	289
9.5.4	FSoE Node Address	290
9.5.5	Instances	290
9.5.6	WorkBench Safety Function Setup	291
9.5.6.1	Project Building (Online)	292
9.5.6.2	Parameters Editor	293
9.5.6.3	Downloading Safety Parameter Packages	297
9.5.6.4	Safety Configuration Diagram	301
9.5.6.5	Parameters Viewer	301
9.5.6.6	Diagnostics	301
9.5.6.7	SafeMotion Settings	303
9.5.7	Parameterization of User Units	304
9.5.7.1	Encoder Settings	304
9.5.7.2	Encoder Unit <=> User Unit	305
9.5.7.3	User Units Scaling	305
9.6	Validation	307
9.6.1	Validation of SafelD	307
9.6.2	Validation of Safety Parameters	307
9.6.3	Validation of Safe I/O Installation	307
9.6.4	Validation Report	308
9.7	Operation	309
9.7.1	Operation States	310
9.7.2	Field Replacement	310
9.8	Safety Faults, Safety Warnings	311
9.8.1	LCD Display	311
9.8.2	Failure Categories	312
9.8.3	SMM Failure Classification and Behavior	312
9.8.4	Drive Safety Faults	313
9.8.5	Safety Warnings	313
9.8.6	Troubleshooting Functional Safety	314
9.9	Functional Safety Parameter Reference	315
9.9.1	Safety Parameters, sorted alphanumeric	327
9.9.1.1	AXIS#.SAFE.ABSOLUTEPOSITION	328
9.9.1.2	AXIS#.SAFE.ABSOLUTEPOSVALID	329
9.9.1.3	AXIS#.SAFE.ACCELERATION	330
9.9.1.4	AXIS#.SAFE.BRAKE#.STATE	331
9.9.1.5	AXIS#.SAFE.ERROR.ACTIVE	332
9.9.1.6	AXIS#.SAFE.FSOE.APPLPARAMLENGTH	333
9.9.1.7	AXIS#.SAFE.FSOE.COMMPARAMLENGTH	334
9.9.1.8	AXIS#.SAFE.FSOE.CONNECTIONID	335
9.9.1.9	AXIS#.SAFE.FSOE.CONNECTIONTYPE	336
9.9.1.10	AXIS#.SAFE.FSOE.LASTERROR	337
9.9.1.11	AXIS#.SAFE.FSOE.PROTOCOLVERSION	338
9.9.1.12	AXIS#.SAFE.FSOE.SAFETYADDR	339
9.9.1.13	AXIS#.SAFE.FSOE.SRACRC	340

9.9.1.14	AXIS#.SAFE.FSOE.STATE	341
9.9.1.15	AXIS#.SAFE.FSOE.WATCHDOGTIME	342
9.9.1.16	AXIS#.SAFE.FUNCTIONGRAPH	343
9.9.1.17	AXIS#.SAFE.FUNCTIONSTATUS	344
9.9.1.18	AXIS#.SAFE.POSITION	346
9.9.1.19	AXIS#.SAFE.RESTARTACK.REQUESTED	347
9.9.1.20	AXIS#.SAFE.SAR_#.ACTIVE	348
9.9.1.21	AXIS#.SAFE.SAR_#.INTERNALSTATE	349
9.9.1.22	AXIS#.SAFE.SBC.ACTIVE	350
9.9.1.23	AXIS#.SAFE.SBT.ERROR	351
9.9.1.24	AXIS#.SAFE.SBT.MOVE	352
9.9.1.25	AXIS#.SAFE.SBT.SBA.ACTIVE	353
9.9.1.26	AXIS#.SAFE.SBT.STATE	354
9.9.1.27	AXIS#.SAFE.SCA_#.INRANGE	355
9.9.1.28	AXIS#.SAFE.SCA_#.INTERNALSTATE	356
9.9.1.29	AXIS#.SAFE.SDIn.INTERNALSTATE	357
9.9.1.30	AXIS#.SAFE.SDIn.MOTIONACTIVE	358
9.9.1.31	AXIS#.SAFE.SDlp.INTERNALSTATE	359
9.9.1.32	AXIS#.SAFE.SDlp.MOTIONACTIVE	360
9.9.1.33	AXIS#.SAFE.SLA.ACTIVE	361
9.9.1.34	AXIS#.SAFE.SLA.INTERNALSTATE	362
9.9.1.35	AXIS#.SAFE.SLI_#.ACTIVE	363
9.9.1.36	AXIS#.SAFE.SLI_#.INTERNALSTATE	364
9.9.1.37	AXIS#.SAFE.SLP_#.ACTIVE	365
9.9.1.38	AXIS#.SAFE.SLP_#.INTERNALSTATE	366
9.9.1.39	AXIS#.SAFE.SLS_#.ACTIVE	367
9.9.1.40	AXIS#.SAFE.SLS_#.INTERNALSTATE	368
9.9.1.41	AXIS#.SAFE.SOS_x.ACTIVE	368
9.9.1.42	AXIS#.SAFE.SOS_x.INTERNALSTATE	369
9.9.1.43	AXIS#.SAFE.SS1_#.ACTIVE	370
9.9.1.44	AXIS#.SAFE.SS1_#.DEC	371
9.9.1.45	AXIS#.SAFE.SS1_#.INTERNALSTATE	372
9.9.1.46	AXIS#.SAFE.SS1_#.MODE	373
9.9.1.47	AXIS#.SAFE.SS2_#.ACTIVE	374
9.9.1.48	AXIS#.SAFE.SS2_#.DEC	375
9.9.1.49	AXIS#.SAFE.SS2_#.INTERNALSTATE	376
9.9.1.50	AXIS#.SAFE.SS2_#.MODE	377
9.9.1.51	AXIS#.SAFE.SSM_#.INRANGE	378
9.9.1.52	AXIS#.SAFE.SSM_#.INTERNALSTATE	379
9.9.1.53	AXIS#.SAFE.SSR_#.ACTIVE	380
9.9.1.54	AXIS#.SAFE.SSR_#.INTERNALSTATE	381
9.9.1.55	AXIS#.SAFE.STO.ACTIVE	382
9.9.1.56	AXIS#.SAFE.STO.REPORTFAULT	383
9.9.1.57	AXIS#.SAFE.TEMPWARNING.ACTIVE	384
9.9.1.58	AXIS#.SAFE.VELOCITY	385
9.9.1.59	AXIS#.SAFEPARAM.ABSOLUTEPOSEN	386
9.9.1.60	AXIS#.SAFEPARAM.ABSOLUTEPOSRANGE	387
9.9.1.61	AXIS#.SAFEPARAM.ABSOLUTEPOSRESETSOURCE	388
9.9.1.62	AXIS#.SAFEPARAM.ABSOLUTEPOSRESETVALUE	389
9.9.1.63	AXIS#.SAFEPARAM.ACCCOMPUTATIONINTERVAL	390
9.9.1.64	AXIS#.SAFEPARAM.AXISCFGEN	391
9.9.1.65	AXIS#.SAFEPARAM.ENCODERSOURCE	392
9.9.1.66	AXIS#.SAFEPARAM.SAR_#.ACCLOWERLIMIT	393
9.9.1.67	AXIS#.SAFEPARAM.SAR_#.ACCUPPERLIMIT	394

9.9.1.68	AXIS#.SAFEPARAM.SAR_#.FAULTREACTION	395
9.9.1.69	AXIS#.SAFEPARAM.SAR_#.FSOE	396
9.9.1.70	AXIS#.SAFEPARAM.SAR_#.FUNCTIONACTIVATION	397
9.9.1.71	AXIS#.SAFEPARAM.SAR_#.SAFEINPUT	398
9.9.1.72	AXIS#.SAFEPARAM.SBC.BRAKETIMEDELAY	399
9.9.1.73	AXIS#.SAFEPARAM.SBC.BRAKE#ATTACHED	400
9.9.1.74	AXIS#.SAFEPARAM.SBC.MUTINGSOURCE	401
9.9.1.75	AXIS#.SAFEPARAM.SBT.FUNCTIONACTIVATION	402
9.9.1.76	AXIS#.SAFEPARAM.SBT.MAXAPPLLOAD	403
9.9.1.77	AXIS#.SAFEPARAM.SBT.MAXMOTIONBRAKE#	404
9.9.1.78	AXIS#.SAFEPARAM.SBT.MAXTIMEINTERVAL	405
9.9.1.79	AXIS#.SAFEPARAM.SBT.TORQUEDURATION	406
9.9.1.80	AXIS#.SAFEPARAM.SCA_#.FUNCTIONACTIVATION	407
9.9.1.81	AXIS#.SAFEPARAM.SCA_#.POSLOWERLIMIT	408
9.9.1.82	AXIS#.SAFEPARAM.SCA_#.POSUPPERLIMIT	409
9.9.1.83	AXIS#.SAFEPARAM.SDB.DELAYBEFORESWITCHING	410
9.9.1.84	AXIS#.SAFEPARAM.SDB.FUNCTIONACTIVATION	411
9.9.1.85	AXIS#.SAFEPARAM.SDB.READBACKSOURCE	412
9.9.1.86	AXIS#.SAFEPARAM.SDI.FAULTREACTION	413
9.9.1.87	AXIS#.SAFEPARAM.SDI.FUNCTIONACTIVATION	414
9.9.1.88	AXIS#.SAFEPARAM.SDI.POSZEROWINDOW	415
9.9.1.89	AXIS#.SAFEPARAM.SDI.VELZEROWINDOW	416
9.9.1.90	AXIS#.SAFEPARAM.SDIn.FSOE	417
9.9.1.91	AXIS#.SAFEPARAM.SDIn.SAFEINPUT	418
9.9.1.92	AXIS#.SAFEPARAM.SDIn.TIMEDELAYMONITORING	419
9.9.1.93	AXIS#.SAFEPARAM.SDlp.FSOE	420
9.9.1.94	AXIS#.SAFEPARAM.SDlp.SAFEINPUT	421
9.9.1.95	AXIS#.SAFEPARAM.SDlp.TIMEDELAYMONITORING	422
9.9.1.96	AXIS#.SAFEPARAM.SLA.ACCLIMIT	423
9.9.1.97	AXIS#.SAFEPARAM.SLA.FAULTREACTION	424
9.9.1.98	AXIS#.SAFEPARAM.SLA.FSOE	425
9.9.1.99	AXIS#.SAFEPARAM.SLA.FUNCTIONACTIVATION	426
9.9.1.100	AXIS#.SAFEPARAM.SLA.SAFEINPUT	427
9.9.1.101	AXIS#.SAFEPARAM.SLI_#.FAULTREACTION	428
9.9.1.102	AXIS#.SAFEPARAM.SLI_#.FSOE	429
9.9.1.103	AXIS#.SAFEPARAM.SLI_#.FUNCTIONACTIVATION	430
9.9.1.104	AXIS#.SAFEPARAM.SLI_#.POSRELOWERLIMIT	431
9.9.1.105	AXIS#.SAFEPARAM.SLI_#.POSRELUPPERLIMIT	432
9.9.1.106	AXIS#.SAFEPARAM.SLI_#.SAFEINPUT	433
9.9.1.107	AXIS#.SAFEPARAM.SLI_#.TIMEDELAYMONITORING	434
9.9.1.108	AXIS#.SAFEPARAM.SLP_#.FAULTREACTION	435
9.9.1.109	AXIS#.SAFEPARAM.SLP_#.FSOE	436
9.9.1.110	AXIS#.SAFEPARAM.SLP_#.FUNCTIONACTIVATION	437
9.9.1.111	AXIS#.SAFEPARAM.SLP_#.POSLOWERLIMIT	438
9.9.1.112	AXIS#.SAFEPARAM.SLP_#.POSUPPERLIMIT	439
9.9.1.113	AXIS#.SAFEPARAM.SLP_#.SAFEINPUT	440
9.9.1.114	AXIS#.SAFEPARAM.SLP_#.TIMEDELAYMONITORING	441
9.9.1.115	AXIS#.SAFEPARAM.SLS_#.DECLIMIT	442
9.9.1.116	AXIS#.SAFEPARAM.SLS_#.DECMONITOREN	443
9.9.1.117	AXIS#.SAFEPARAM.SLS_#.FAULTREACTION	444
9.9.1.118	AXIS#.SAFEPARAM.SLS_#.FSOE	445
9.9.1.119	AXIS#.SAFEPARAM.SLS_#.FUNCTIONACTIVATION	446
9.9.1.120	AXIS#.SAFEPARAM.SLS_#.SAFEINPUT	447
9.9.1.121	AXIS#.SAFEPARAM.SLS_#.TIMEDELAYDECMONITORING	448

9.9.1.122	AXIS#.SAFEPARAM.SLS_#.TIMEFORVELINLIMITS	449
9.9.1.123	AXIS#.SAFEPARAM.SLS_#.TIMETOVELMONITORING	450
9.9.1.124	AXIS#.SAFEPARAM.SLS_#.VELLIMIT	451
9.9.1.125	AXIS#.SAFEPARAM.SOS_x.FSOE	451
9.9.1.126	AXIS#.SAFEPARAM.SOS_x.FUNCTIONACTIVATION	452
9.9.1.127	AXIS#.SAFEPARAM.SOS_x.POSZEROWINDOW	452
9.9.1.128	AXIS#.SAFEPARAM.SOS_x.RESTARTACKBEHAVIOR	453
9.9.1.129	AXIS#.SAFEPARAM.SOS_x.RESTARTACKSOURCE	454
9.9.1.130	AXIS#.SAFEPARAM.SOS_x.SAFEINPUT	454
9.9.1.131	AXIS#.SAFEPARAM.SOS_x.TIMEDELAYMONITORING	455
9.9.1.132	AXIS#.SAFEPARAM.SOS_x.VELMONITOREN	455
9.9.1.133	AXIS#.SAFEPARAM.SOS_x.VELZEROWINDOW	456
9.9.1.134	AXIS#.SAFEPARAM.SPEEDCOMPUTATIONINTERVAL	457
9.9.1.135	AXIS#.SAFEPARAM.SS1_#.DECLIMIT	458
9.9.1.136	AXIS#.SAFEPARAM.SS1_#.FSOE	459
9.9.1.137	AXIS#.SAFEPARAM.SS1_#.FUNCTIONACTIVATION	460
9.9.1.138	AXIS#.SAFEPARAM.SS1_#.SAFEINPUT	461
9.9.1.139	AXIS#.SAFEPARAM.SS1_#.TIMEDELAYDECMONITORING	462
9.9.1.140	AXIS#.SAFEPARAM.SS1_#.TIMEFORVELZERO	463
9.9.1.141	AXIS#.SAFEPARAM.SS1_#.TIMETOSTO	464
9.9.1.142	AXIS#.SAFEPARAM.SS1_#.VELDECMONITOREN	465
9.9.1.143	AXIS#.SAFEPARAM.SS1_#.VELZEROWINDOW	466
9.9.1.144	AXIS#.SAFEPARAM.SS2_#.DECLIMIT	467
9.9.1.145	AXIS#.SAFEPARAM.SS2_#.DECMONITOREN	468
9.9.1.146	AXIS#.SAFEPARAM.SS2_#.FAULTREACTION	469
9.9.1.147	AXIS#.SAFEPARAM.SS2_#.FSOE	470
9.9.1.148	AXIS#.SAFEPARAM.SS2_#.FUNCTIONACTIVATION	471
9.9.1.149	AXIS#.SAFEPARAM.SS2_#.SAFEINPUT	472
9.9.1.150	AXIS#.SAFEPARAM.SS2_#.TIMEDELAYDECMONITORING	473
9.9.1.151	AXIS#.SAFEPARAM.SS2_#.TIMEFORVELZERO	474
9.9.1.152	AXIS#.SAFEPARAM.SS2_#.TIMETOSOS	475
9.9.1.153	AXIS#.SAFEPARAM.SSM_#.FUNCTIONACTIVATION	476
9.9.1.154	AXIS#.SAFEPARAM.SSM_#.VELLOWERLIMIT	477
9.9.1.155	AXIS#.SAFEPARAM.SSM_#.VELUPPERLIMIT	478
9.9.1.156	AXIS#.SAFEPARAM.SSR_#.DECLIMIT	479
9.9.1.157	AXIS#.SAFEPARAM.SSR_#.DECMONITOREN	480
9.9.1.158	AXIS#.SAFEPARAM.SSR_#.FAULTREACTION	481
9.9.1.159	AXIS#.SAFEPARAM.SSR_#.FSOE	482
9.9.1.160	AXIS#.SAFEPARAM.SSR_#.FUNCTIONACTIVATION	483
9.9.1.161	AXIS#.SAFEPARAM.SSR_#.SAFEINPUT	484
9.9.1.162	AXIS#.SAFEPARAM.SSR_#.TIMEDELAYDECMONITORING	485
9.9.1.163	AXIS#.SAFEPARAM.SSR_#.TIMEFORVELINLIMITS	486
9.9.1.164	AXIS#.SAFEPARAM.SSR_#.TIMETOVELMONITORING	487
9.9.1.165	AXIS#.SAFEPARAM.SSR_#.VELLOWERLIMIT	488
9.9.1.166	AXIS#.SAFEPARAM.SSR_#.VELUPPERLIMIT	489
9.9.1.167	AXIS#.SAFEPARAM.STO.FSOE	490
9.9.1.168	AXIS#.SAFEPARAM.STO.FUNCTIONACTIVATION	491
9.9.1.169	AXIS#.SAFEPARAM.STO.RESTARTACKMODE	492
9.9.1.170	AXIS#.SAFEPARAM.STO.RESTARTACKSOURCE	493
9.9.1.171	AXIS#.SAFEPARAM.STO.SAFEINPUT	494
9.9.1.172	AXIS#.SAFEPARAM.UNIT.ACCFACTOR	495
9.9.1.173	AXIS#.SAFEPARAM.UNIT.ACCINENC	496
9.9.1.174	AXIS#.SAFEPARAM.UNIT.ACCINUSER	497
9.9.1.175	AXIS#.SAFEPARAM.UNIT.ACCLABEL	498

9.9.1.176	AXIS#.SAFEPARAM.UNIT.POSFACTOR	499
9.9.1.177	AXIS#.SAFEPARAM.UNIT.POSINENC	500
9.9.1.178	AXIS#.SAFEPARAM.UNIT.POSINUSER	501
9.9.1.179	AXIS#.SAFEPARAM.UNIT.POSLABEL	502
9.9.1.180	AXIS#.SAFEPARAM.UNIT.VELFACOR	503
9.9.1.181	AXIS#.SAFEPARAM.UNIT.VELINENC	504
9.9.1.182	AXIS#.SAFEPARAM.UNIT.VELINUSER	505
9.9.1.183	AXIS#.SAFEPARAM.UNIT.VELLABEL	506
9.9.1.184	BRAKE#.SAFE.SBT.ELAPSED	507
9.9.1.185	BRAKE#.SAFE.SBT.STATE	508
9.9.1.186	SAFE.CFGERROR	509
9.9.1.187	SAFE.CHANGEPASSWORD	510
9.9.1.188	SAFE.CLEARSAFEID	511
9.9.1.189	SAFE.CRC	512
9.9.1.190	SAFE.DEVICECRC	513
9.9.1.191	SAFE.ERROR	514
9.9.1.192	SAFE.ERRORINSTANCE	516
9.9.1.193	SAFE.ID	517
9.9.1.194	SAFE.IDANDCRC	518
9.9.1.195	SAFE.INVALIDATEPARAMS	519
9.9.1.196	SAFE.MONITOR#.AXIS	520
9.9.1.197	SAFE.MONITOR#.DATA	521
9.9.1.198	SAFE.MONITOR#.INSTANCE	522
9.9.1.199	SAFE.MONITOR#.SOURCE	523
9.9.1.200	SAFE.STATE	524
9.9.1.201	SAFE.SWITCH	525
9.9.1.202	SAFE.VALIDATEPARAM	526
9.9.1.203	SAFE.VALIDATIONLOG	527
9.9.1.204	SAFE.VERIFYFW	529
9.9.1.205	SAFEPARAM.ENCODERHDSLTYPE1	530
9.9.1.206	SAFEPARAM.ENCODERHDSLTYPE2	531
9.9.1.207	SAFEPARAM.HDSLCHAN1SINGLETURNRES1	531
9.9.1.208	SAFEPARAM.HDSLCHAN1SINGLETURNRES2	532
9.9.1.209	SAFEPARAM.IOFAILUREACKSOURCE	533
9.9.1.210	SAFEPARAM.SAFEFIELDBUS.ACTIVATION	534
9.9.1.211	SAFEPARAM.SIN.DISTINCTPULSE	535
9.9.1.212	SAFEPARAM.SINDUAL#.EN	536
9.9.1.213	SAFEPARAM.SOUTDUAL#.EN	537
9.9.1.214	SAFEPARAM.SOUTDUAL#.SOURCE	538
9.9.1.215	SAFEPARAM.SOUT#.SOURCE	540
9.9.1.216	SINDUAL#.STATE	542
9.9.1.217	SIN#.STATE	543
9.9.1.218	SOUTDUAL#.STATE	544
9.9.1.219	SOUT#.STATE	545
10	Approvals	546
10.1	Conformance with UL/cUL	547
10.1.1	3-12 A drives	547
10.1.2	7V24S 24 A drives	548
10.2	Conformance with EU	549
10.2.1	Functional Safety	549
10.2.2	Conformance with RoHS	550
10.2.3	Conformance with REACH	550
10.2.3.1	Waste Framework Directive Substances of Concern in Products (SCIP) Database	550
10.3	Conformance with UK	550

11 Index	551
12 Record of Document Revisions	553
12.1 Limitations	553
Support and Services	555

1 General

1.1 About this Installation Manual	19
1.2 Symbols Used	19
1.3 Abbreviations Used	21

1.1 About this Installation Manual

The AKD2G Installation Manual describes the AKD2G series of digital drives and includes information to safely install the product.

Manual updates can be downloaded from the Kollmorgen website (www.kollmorgen.com).

Product information for use consists of:





- **Safety Notes:** Multi-language document with safety information, part of product delivery in Europe, printed on paper DIN A5.
- **Installation Manual:** Describes the product series of digital drives and includes information to safely install it. Contact Kollmorgen customer support for a free printed copy of the installation manual.
- **WorkBench Online Help:** Describes how to use your drive in common applications. It also provides tips for maximizing the system performance with your product. The *Online Help* includes the *Parameter and Command Reference Guide* which provides information for the parameters and commands used to program your drive.
- **CAN-BUS Communication:** Describes how to use your drive in CANopen applications.
- **EtherCAT® Communication:** Describes how to use your drive in EtherCAT applications.
- **EtherNet/IP™ Communication:** Describes how to use your drive in EtherNet/IP applications.
- **Sercos®III Communication:** Describes how to use your drive in Sercos applications.
- **PROFINET® RT Communication:** Describes how to use your drive in PROFINET RT applications.
- **SynqNet Communication:** Describes how to use your drive in SynqNet applications.
- **Accessories Manual:** Provides information for accessories like cables and regen resistors used with your product. Regional variants of this manual exist.







This document is valid for AKD2G single axis drive or dual axis drive with 110 V to 240 V or 240 V to 480 V mains voltage.

- Output stages: 3 A or 6 A, 12 A or 24 A rated current
- Programmability options: Base drive or Position Indexer drive
- Connectivity options: analog, CANopen, EtherCAT, PROFINET, EtherNet/IP
- I/O options: Extended I/O (X22), Feedback&EEO (X23)
- Functional Safety Option: FS3 with STO, SS1-t, SS1-r, SS2, SOS, SLS, SSM, SSR, SDI, SLA, SAR, SLI, SLP, SCA, SBC, SDB, SBT; SIL3 PLe













1.2 Symbols Used

1.2.1 Warning Symbols

Symbol	Indication
 DANGER	Indicates a hazardous situation which, if not avoided, will result in death or serious injury.
 WARNING	Indicates a hazardous situation which, if not avoided, could result in death or serious injury.
 CAUTION	Indicates a hazardous situation which, if not avoided, could result in minor or moderate injury.
 NOTICE	Indicates situations which, if not avoided, could result in property damage.
 NOTE	This symbol indicates important notes.

Symbol	Indication
	High Noise Pollution. The type of danger is specified by the text next to the symbol.
	Warning of a danger (general). The type of danger is specified by the text next to the symbol.
	Warning of danger from electricity and its effects.
	Warning of danger from hot surface.
	Warning of danger from suspended loads.
	Warning of danger from automatic start.
	Warning of danger from molten particle projection.

1.2.2 Drawing Symbols

Symbol	Description	Symbol	Description
	Signal ground		Diode
	Chassis ground		Relay
	Protective earth		Relay switch off delayed
	Resistor		Normally open contact
	Fuse		Normally closed contact
	State-of-the-art firewall		EMC filter

1.3 Abbreviations Used

Abbreviations related to functional safety (→ # 197).

Abbreviation	Meaning
(→ # 53)	"see page 53" in this document
→ xyz	"see chapter xyz" in this document
Ω	Ohms
A#, AXIS#	A# or AXIS# are placeholders for the axis number. Used with parameters or signal names
AGND	Analog ground
AquadB	In quadrature output, used for incremental encoder emulation
AMSL	Above mean sea level
Axis	Depends on context, either one AKD2G output stage or one load axis of the full motion system.
CAT	Category
CE	Communauté Européenne
COM	Serial interface for a personal computer
DGND	Digital ground
EEPROM	Electrically erasable programmable memory
EEO	Emulated Encoder Output
EMC	Electromagnetic compatibility
EMF	Electromagnetic force
FS1, FS2, FS3	Functional Safety Option 1, 2, 3
FSoE	Fail safe over EtherCAT
KAS	Kollmorgen Automation Suite
KAS IDE	Setup software (Kollmorgen Automation Suite Integrated Development Environment)
KDN	Kollmorgen Developer Network
LED	Light-emitting diode
LSB	Low significant byte (or bit)
MSB	Most significant byte (or bit)
NI	Zero pulse
OSSD	Output Signal Switching Device
PE	Protective earth
PELV	Protective Extra Low Voltage
PLC	Programmable logic control
PWM	Pulse-width modulation
RAM	Random access memory (volatile memory)
RBrake/RB	Regen resistor (also called a brake resistor)
RBext	External regen resistor
RBint	Internal regen resistor
RCD	Residual current device
RES	Resolver
S1	Continuous operation
tbd	To be determined (in process)
VAC	Volts, alternating current
VDC	Volts, direct current

2 Product Safety

To avoid possible damage, read and follow the instructions.

2.1 You should pay attention to this	23
2.2 Use as Directed	25
2.3 Prohibited Use	25
2.4 Warning note labels	26
2.5 Shock-hazard Protection	26
2.6 Stop / Emergency Stop / Emergency Off	28

2.1 You should pay attention to this

This section helps to recognize risks and avoid dangers to people and objects.

Specialist staff required!

The devices are intended for industrial applications.

Machine builders must employ qualified personnel. Qualified personnel are people who have been trained to transport, install, commission, and operate electrical drives.

- Transport, storage, unpacking: Only by personnel with knowledge of handling electrostatically sensitive components.
- Mechanical installation: Only by personnel with mechanical expertise.
- Electrical installation: Only by personnel with expertise in electrical engineering.
- Basic tests / setup: Only by personnel with expertise in electrical engineering and drive technology.

The qualified personnel must know and observe ISO 12100 / IEC 60364 / IEC 60664 and national accident prevention regulations.

Read the documentation!

Read the available documentation before installation and commissioning. Improper handling of the devices can cause harm to people or damage to property. The operator of systems using the drive system must ensure that all personnel who work with the drive read and understand the manual before using the drive.

Check Hardware Revision!

Check the Hardware Revision Number of the product (see product label). This number is the link between your product and the manual. The product Hardware Revision Number must match the Hardware Revision Number on the cover page of the manual.

Pay attention to the technical data!

Adhere to the technical data and the specifications on connection conditions. If permissible voltage values or current values are exceeded, the devices can be damaged. Unsuitable motor or wrong wiring will damage the system components. Check the combination of drive and motor. Compare the rated voltage and current of the units.

Perform a risk assessment!

The manufacturer of the machine must generate a risk assessment for the machine, and take appropriate measures to ensure that unforeseen movements cannot cause injury or damage to any person or property. Additional requirements on specialist staff may also result from the risk assessment.

Automatic restart!



Risk of death or serious injury for humans working in the machine. The drive might restart automatically after power on, voltage dip or interruption of the supply voltage, depending on the parameter setting.

If the parameter `AXIS#.ENDEFAULT` is set to 1, then place a warning sign on the machine (Warning: Automatic Restart at Power On) and ensure, that power on is disabled, while humans are in a dangerous zone of the machine. In case of using an undervoltage protection device, you must observe EN 60204-1:2006 chapter 7.5 .

ATTENTION: The drive is ready to operate with pre-configured STO function.

Observe electrostatically sensitive components!

The devices contain electrostatically sensitive components which may be damaged by incorrect handling. Electrostatically discharge your body before touching the device. Avoid contact with highly insulating materials (artificial fabrics, plastic film etc.). Place the device on a conductive surface.

Hot surface!



Risk of minor burns! Drives may have hot surfaces during operation. The housing can reach temperatures above 80 °C. Measure the temperature and wait until the housing has cooled down below 40 °C before touching it.

Earthing!



Risk of electric shock! Ensure that the drive is safely earthed to the PE (protective earth) busbar in the switch cabinet. Without low-resistance earthing personal protection is at risk.

Leakage Current!

Since the leakage current to PE is more than 3.5 mA, double the PE connection or use a connecting cable with a cross-section >10 mm² to be compliant with IEC61800-5-1.

Deviating measures according to regional standards might be possible.

High voltages!



The equipment produces high electric voltages up to 900 V. Lethal danger exists at live parts of the device. Do not open or touch the equipment during operation. Keep all covers and cabinet doors closed. Built-in protection measures such as insulation or shielding may not be removed. Work on the electrical installation may only be performed by trained and qualified personnel, in compliance with the regulations for safety at work, and only with switched off mains supply, and secured against restart.

Never undo any electrical connections to the drive while it is live. There is a danger of electrical arcing with damage to contacts and personal injury. Wait at least 5 minutes after disconnecting the drive from the main supply power before touching potentially live sections of the equipment (such as contacts) or removing any connections.

Always measure the voltage in the DC bus link and wait until the voltage is below 50 V before handling components.

Projection of molten particles!



If particles fall into the drive or the drive has been damaged, molten drive component particles may be ejected causing injuries. Shut down the drive and wear appropriate protective gear during maintenance work, troubleshooting and fault rectification. (→ # 34)

Functional Safety!

The assessment of the safety functions according to ISO 13849 or IEC 62061 (IEC 61508) must finally be done by the user.

Reinforced Insulation

Thermal sensors, motor holding brakes and feedback systems built into the connected motor must have reinforced insulation (according to IEC61800-5-1) against system components with power voltage, according to the required application test voltage. All Kollmorgen components meet these requirements.

Never modify the drive!

Never modify the drive hardware without permission of the manufacturer. Opening the housing causes loss of warranty.

High noise pollution!



Fans generate noise of up to 76 dBA when operating at maximum load. This can lead to hearing damage. Keep the cabinet doors closed during operation. Use ear protection if the control cabinet has to be opened during servicing. The operator must provide ear protection and monitor its use depending on the daily noise exposure level determined.

2.2 Use as Directed

The AKD2G drives are exclusively intended for driving suitable synchronous servomotors with closed-loop control of torque, speed, and/or position.

Your drive is a component that is built into electrical plants or machines and can only be operated as integral component of these plants or machines. The manufacturer of the machine used with a drive must generate a risk assessment for the machine. When the drive is built into a machine or plant, it must not be used until it has been established that the machine or plant fulfills the requirements of the regional directives.

Cabinet and wiring

Only operate your device in a closed control cabinet suitable for the ambient conditions (→ # 43). Make sure to keep the temperature within the cabinet below 40 °C (or 60 °C when using extended range operation with derating) with help of ventilation or cooling.

Only use copper conductors for wiring. The conductor cross-sections can be derived from the standard IEC 60204 (alternatively for AWG cross-sections: NEC Table 310-16, 75 °C column).

Power supply

The drives can be supplied by 1, 2 or 3 phase (TN-S or TT) or DC industrial supply networks.

Drives in the AKD2G series can be supplied as follows:

- AKD2G-Sxx-6Vxx:
1, 2 or 3 phase industrial supply networks (not more than 10 kA symmetrical rated current at 120 V and 240 V) or DC supply.
- AKD2G-Sxx-7Vxx:
3 phase industrial supply networks (not more than 10 kA symmetrical rated current at 240 V, 400 V and 480 V) or DC supply.

Connection to other voltage types of supply networks is possible with an additional isolating transformer.

Repeated overvoltages between phases (L1, L2, L3) and the housing of the drive must not exceed 1000 V peak. In accordance with EN 61800-3, voltage spikes (< 50 µs) between phases must not exceed 1000 V. Voltage spikes (< 50 µs) between a phase and the housing must not exceed 2000 V.

Motor voltage rating

The rated voltage of the motors must be at least as high as the DC bus link voltage divided by $\sqrt{2}$ produced by the drive ($U_{nMotor} \geq U_{DC}/\sqrt{2}$).

Functional Safety

NOTICE

- The network, to which the drive is connected, must be secured according to state-of-the-art information technology security requirements.
- The user IT specialists shall analyze whether further security requirements are applicable to ensure functional safety.

Review the chapter "Use as Directed" in the Functional Safety section before using safety functionality.

2.3 Prohibited Use

Other use than that described in the previous "Use as Directed" section is not intended and can lead to personnel injuries and equipment damage. The drive may not be used with a machine that does not comply with appropriate national directives or standards. The use of the drive in the following environments is also prohibited:

- potentially explosive areas
- environments with corrosive and/or electrically conductive acids, alkaline solutions, oils, vapors, dusts
- ships or offshore applications

NOTICE

The drive must not be connected directly to the Internet. If the network, to which the drive is connected, is not secured according to state-of-the-art information technology, this could be a functional safety risk.

2.4 Warning note labels

2.4.1 Notes placed on the product



2.4.2 Adhesive label in the package

NOTICE

Follow the instructions given on the adhesive labels in the package. If a warning note label is damaged, it must be replaced immediately.

2.5 Shock-hazard Protection

2.5.1 Leakage current

Leakage current via the PE conductor results from the combination of equipment and cable leakage currents. The leakage current frequency pattern includes a number of frequencies, whereby the residual-current circuit breakers definitively evaluate the 50 Hz current. For this reason, the leakage current cannot be measured using a conventional multimeter. Contact our application department for help to calculate the leakage current in your application.

NOTE

Since the leakage current to PE is more than 3.5mA, in compliance with IEC 61800-5-1 the PE connection must either be doubled or a connecting cable with a cross-section >10mm² must be used. Use the PE terminal and the PE connection screws in order to fulfill this requirement.

The following measures can be used to minimize leakage currents:

- Reduce the length of the engine cable.
- Use low capacitance motor cables (→ # 64).

2.5.2 Residual current protective device (RCD)

In conformity with IEC 60364-4-41 - Regulations for installation and IEC 60204 - Electrical equipment of machinery, residual current protective devices (RCDs) can be used provided the requisite regulations are complied with. The AKD2G is a 3-phase system with a B6 bridge. Therefore, RCDs which are sensitive to all currents must be used in order to detect any DC fault current.

Rated residual currents in the RCDs:

10 to 30 mA	Protection against "indirect contact" (personal fire protection) for stationary and mobile equipment, as well as for "direct contact".
--------------------	----------------------------------------------------------------------------------------------------------------------------------------

50 to 30 mA	Protection against "indirect contact" (personal fire protection) for stationary equipment
--------------------	-------------------------------------------------------------------------------------------

NOTE

Recommendation: In order to protect against direct contact (with motor cables shorter than 5 m) Kollmorgen recommends that each drive be protected individually using a 30 mA RCD which is sensitive to all currents.

If you use a selective RCD, the more intelligent evaluation process will prevent spurious tripping of the RCD.

2.5.3 Isolating transformers

When protection against indirect contact is absolutely essential despite a higher leakage current, or when an alternative form of shock-hazard protection is sought, the AKD2G can also be operated by using an isolating transformer. A ground-leakage monitor can be used to monitor for short circuits.

NOTE

Keep the length of wiring between the transformer and the drive as short as possible.

2.6 Stop / Emergency Stop / Emergency Off

The control functions Stop, Emergency Stop, and Emergency Off are defined by IEC 60204.

Notes for functional safety aspects of these functions can be found in ISO 13849 and IEC 62061(IEC 61508).

NOTE

The parameter `AXIS#.DISMODE` must be set to implement the different stop categories for software disabling. Consult the *WorkBench Online Help* for configuring the parameter.



WARNING

Vertical load could fall!

Serious injury could result when the load is not properly blocked. The internal brake function does not ensure functional safety.

- Functional Safety can be ensured with configured SBC (→ # 240) only.
- For SIL 3 a second (external) motor brake for an axis is required. For single axis drives this brake can be connected to X4 (→ # 115). For dual axis drives the additional brake must be controlled from another source (e.g. from the other axis or externally from a safety controller). The brakes can be mapped to an axis with WorkBench.
- The Hardware Enable does not initiate a controlled stop but switches off the power stage immediately.
- Set parameter `AXIS#.MOTOR.BRAKEIMM` to 1 with vertical axes, to apply the brake immediately after faults or Hardware Disable.
- Risk assessment of the application determines the necessary measures.

2.6.1 Stop

The stop function shuts down the machine in normal operation.

The stop function is defined by IEC 60204.

NOTE

The Stop Category must be determined by a risk evaluation of the machine.

Stop function must have priority over assigned start functions. The following stop categories are defined:

Stop Category 0

Shut-down by immediate switching-off the energy supply to the drive machinery (this is an uncontrolled shut-down). For stop without using safety functions like STO, set `AXIS#.DISMODE` to 0.

The safety function STO stops the drive as required by Stop Category 0 (IEC 60204).

Stop Category 1

A controlled shut-down, whereby the energy supply to the drive machinery is maintained to perform the shut-down, and the energy supply is only interrupted when the shut-down has been completed.

For stop without using safety functions like SS1, set `AXIS#.DISMODE` to 2.

The safety function SS1 stops the drive as required by Stop Category 1 (IEC 60204).

Stop Category 2

A controlled shut-down, whereby the energy supply to the drive machinery is maintained. This category shall be realized with a safety function like SS2. Safety function SS2 stops the drive as required by Stop Category 2 (IEC 60204).

Stop Category 0 and Stop Category 1 stops must be operable independently of the operating mode, whereby a Category 0 stop must have priority.

If necessary, provision must be made for the connection of protective devices and lock-outs. If applicable, the stop function must signal its status to the control logic. A reset of the stop function must not create a hazardous situation.

2.6.2 Emergency Stop

The Emergency Stop function is used for the fastest possible shutdown of the machine in a dangerous situation. The Emergency Stop function is defined by IEC 60204. Principles of emergency stop devices and functional aspects are defined in ISO 13850.

The Emergency Stop function will be triggered by the manual actions of a single person. It must be fully functional and available at all times. The user must understand instantly how to operate this mechanism (without consulting references or instructions).

NOTE

The Stop Category for the Emergency Stop must be determined by a risk evaluation of the machine.

In addition to the requirements for stop, the Emergency Stop must fulfill the following requirements:

- Emergency Stop must have priority over all other functions and controls in all operating modes.
- The energy supply to any drive machinery that could cause dangerous situations must be switched off as fast as possible, without causing any further hazards (Stop Category 0) or must be controlled in such a way, that any movement that causes danger, is stopped as fast as possible (Stop Category 1).
- The reset must not initiate a restart.

2.6.3 Emergency Off

The Emergency Off function is used to switch-off the electrical power supply of the machine. This is done to prevent users from any risk from electrical energy (for example electrical impact). Functional aspects for Emergency Off are defined in IEC 60364-5-53.

The Emergency Off function will be triggered by the manual actions of a single person.

NOTE

The result of a risk evaluation of the machine determines the necessity for an Emergency Off function.

Emergency Off is done by switching off the supply energy by electro-mechanical switching devices. This results in a category 0 stop. If this stop category is not possible in the application, then the Emergency Off function must be replaced by other measures (e.g., by protection against direct touching).

3 Product life cycle handling

3.1 Transport	31
3.2 Packaging	31
3.3 Storage	31
3.4 Installation, setup and normal operation	31
3.5 Decommissioning	32
3.6 Maintenance and Cleaning	32
3.7 Disassembly	32
3.8 System Repair	34
3.9 Disposal	34

3.1 Transport

Transport the AKD2G in accordance with IEC 61800-2 as follows:

- Transport only by qualified personnel in the manufacturer's original recyclable packaging.
- **NOTICE:** Avoid shocks while transporting.
- Vibration/Shock: AKD2G is tested for environmental class 2M1 of IEC 60721-3-2.
- Store at or below maximum stacking height 8 cartons (see "Storage" (→ # 31))
- Transport only within specified temperature ranges:
-25 to +70 °C, max. rate of change 20 K/hour, class 2K3.
- Transport only within specified humidity:
max. 95% relative humidity at +40°C, no condensation, class 2K3.

NOTICE

The drives contain electrostatically sensitive components that can be damaged by incorrect handling. Electrostatically discharge yourself before touching the drive. Avoid contact with highly insulating materials, such as artificial fabrics and plastic films. Place the drive on a conductive surface.

If the packaging is damaged, check the unit for visible damage. Inform the shipper and the manufacturer of any damage to the package or product.

3.2 Packaging

The AKD2G packaging consists of recyclable cardboard with inserts and a label on the outside of the box.

Model	Package (mm) HxWxL	Total Weight (kg)
AKD2G-Sxx-6V03 to 6V12	158 x 394 x 292	4.2
AKD2G-Sxx-7V03 to 7V12	158 x 394 x 292	4.3
AKD2G-Sxx-7V24	158 x 394 x 292	7.6

NOTE

Mating connectors are **not** included in the package of a standard drive.

Mating connectors are included when the drive is ordered with accessories (append "-A" to the model number).

3.3 Storage

Store the AKD2G in accordance with EN 61800-2 as follows:

- Store only in the manufacturer's original recyclable packaging.
- Store at or below a maximum stacking height of 8 cartons.
- Store only within the specified temperature ranges:
 - -25 to +55 °C, max. rate of change 20 K/hour, class 1K4.
- Store only within the specified humidity:
 - 5 to 95% relative humidity, no condensation, class 1K3.
- Store in accordance with the following duration requirements:
 - Less than 1 year: without restriction.
 - More than 1 year: capacitors must be re-formed before setting up and operating the drive.
 - Re-forming procedures are described in the KDN ([Forming](#)).

3.4 Installation, setup and normal operation

- Mechanical installation (→ # 56)
- Electrical installation (→ # 60)

- Setup (→ # 176)

Normal operation tested for environmental class 3K3 according to EN 61800-2 (→ # 43).

The manufacturer of the machine defines the necessary end user expertise based on the risk assessment for the machine and describes the requirements for normal operation based on the application.

3.5 Decommissioning

NOTICE

Only professional staff who are qualified in electrical engineering are allowed to decommission parts of the system.

DANGER: Lethal Voltages!

There is a danger of serious personal injury or death by electrical shock or electrical arcing.

1. Switch off the main switch of the switchgear cabinet.
2. Secure the system against restarting.
3. Block the main switch.
4. Wait at least 5 minutes after disconnecting.

3.5.1 Volatile and Non-volatile Memory

[Letter of Volatility for AKD Drives](#): This letter of volatility describes volatile and non-volatile media as well as storage media on the AKD. Use this document to comply with security requirements.

[Letter of Volatility for AKD2G Drives](#): This letter of volatility describes volatile and non-volatile media as well as storage media on the AKD2G. Use this document to comply with security requirements.

For the Letter of Volatility go to [Letter of Volatility for AKD Drives](#).

For the Letter of Volatility go to <https://www.kollmorgen.com/en-us/developer-network/letter-volatility-akd2g-drives>.

3.6 Maintenance and Cleaning

The device does not require maintenance, it should be inspected once a year by professional staff.

NOTICE

Do not immerse or spray the device.
Avoid that liquid enters the device.
The inside of the unit can only be cleaned by the manufacturer.
Opening the device voids the warranty.

3.6.1 Cleaning Procedure

1. Decommission the device.
See "Decommissioning" (→ # 32).
2. Casing: Clean with Isopropanol or similar cleaning solution.
CAUTION: Highly Flammable! Risk of injury by explosion and fire.
 - Observe the safety notes given on the cleaning liquid package.
 - Wait at least 30 minutes after cleaning before putting the device back into operation.
3. Protective grill on fan: Clean with a dry brush.

3.7 Disassembly

NOTICE

Only professional staff who are qualified in electrical engineering are allowed to disassemble parts of the system.

1. Decommission the device.
See "Decommissioning" (→ # 32).

2. Check temperature.

CAUTION: High Temperature! Risk of minor burns.

During operation, the heat sink of the drive may reach temperatures above 80 °C (176 °F).

Before touching the device, check the temperature and wait until it has cooled below 40 °C (104 °F).

3. Remove the connectors.

Disconnect the potential earth connection last.

4. Demount: Loosen the fastening screws.

Remove the device.

3.8 System Repair

NOTICE

Only professional staff who are qualified in electrical engineering are allowed to exchange parts of the drive system.

CAUTION: Automatic Start! During replacement work a combination of hazards and multiple episodes may occur.

- Work on the electrical installation may only be performed by trained and qualified personnel, in compliance with the regulations for safety at work, and only with use of prescribed personal safety equipment.

3.8.1 Exchange of the Controller

Only the manufacturer can repair the controller.

Opening the controller or housing voids the warranty.

1. Decommission the device.
See "Decommissioning" (→ # 32).
2. Demount the device.
See "Disassembly" (→ # 32).
3. Send the device to the manufacturer.
See "Disposal" (→ # 34).
4. Install a new device as described in the Installation Manual.
5. Setup the system as described in the Installation Manual.

3.8.2 Exchange of Other Drive System Parts

Use this procedure if parts of the drive system (e.g., cables) must be replaced.

1. Decommission the device.
See "Decommissioning" (→ # 32).
2. Exchange the parts.
3. Check all connections for correct fastening.
4. Setup the system as described in the Installation Manual.

3.9 Disposal

NOTICE

- Dispose the unit after the mission time at the latest. Information on the start of the mission time can be found here: (Nameplate, → # 37)
- To dispose the unit properly, contact a certified electronic scrap disposal merchant.

In accordance with the WEEE-2012/19/EU guideline and similar, the manufacturer accepts returns of old devices and accessories for professional disposal. The sender needs to cover the costs for the transport.

Contact Kollmorgen to clarify the logistics.

Send the devices in the original packaging to the manufacturer address:

North America	South America
KOLLMORGEN 201 West Rock Road Radford, VA 24141, USA	Altra Industrial Motion do Brasil Equipamentos Industriais LTDA. Avenida João Paulo Ablas, 2970 Jardim da Glória, Cotia – SP CEP 06711-250, Brazil
Europe	Asia
KOLLMORGEN s.r.o Evropská 864664 42 Modřice, Brno Czech Republic	KOLLMORGEN Room 302, Building 5, Lihpao Plaza, 88 Shenbin Road, Minhang District, Shanghai, China.

4 Package

4.1 Package Supplied	37
4.2 Nameplate	37
4.3 Part Number Scheme	37

4.1 Package Supplied

When a standard drive from the AKD2G series is delivered, the following items are included in the drive package:

- AKD2G
- Printed copy of *AKD2G® Safety Notes*
- Panel safety label
- **ATTENTION:** Drive is ready to operate with pre-configured STO function.

NOTE

Mating connectors are **not** included in the package of a standard drive.

Mating connectors are included when the drive is ordered with accessories (append “-A” to the model number).

Mating connectors listed below are never delivered with the drive. These mating connectors are usually part of the cables:

- Motor mating connector (X1, X2),
- SubD (X23, X41) for Feedback,
- RJ25 (X13, X14) for CAN Bus, and
- RJ45 (X11, X12, X20) Service and EtherNet Fieldbus.

Accessories sold separately

Accessories must be ordered separately if required, see regional Accessories Manual.

- EMC filters for mains supply voltage, categories C2 or C3
- External regen resistor
- Mating connector kits
- Motor mating connector
- Hybrid cable, assembled hybrid motor cables are available for all regions
- Motor cable, assembled motor cables are available for all regions
- Feedback cable, assembled feedback cables are available for all regions
- SFA (Smart Feedback Adapter)
- EtherNet service cable

4.2 Nameplate

A nameplate is attached to the side of the drive. The picture below is similar to the nameplate on the device.

KOLLMORGEN™ Customer Support:
 201 W. Rock Road North America: +1 (540) 633-3400
 Radford, VA 24141 Europe: +49 (0) 2102-9394-0
 Italy: +39 (0) 362-594260

Model No: **AKD2G-SPE-6V06D-A1F3-0000**
 Serial No: **R2-1900-00000** HW Rev: **A**
 MAC Address: **00-23-1B-00-00-00**

Ratings at 40°C (See manual for ratings >40°C)		
	<i>INPUT</i>	<i>OUTPUT</i>
Voltage	120/240 Vac	0-240 Vac
Frequency	50/60 Hz	0-599Hz
Phase	1 Ph/3 Ph	3 Ph
FL Current	13/9.7 Arms	6/6 Arms
Power @ 240 Vac	3.1/4.0 KVA	

Enclosure Protection Rating: **IP20**

Before use, refer to CD for installation and safety information.
 Assembled in USA www.kollmorgen.com Patents, Patents Pending

UK
CA
CE
UL US LISTED
IND. CONT. EQ.
E141084
RoHS

4.3 Part Number Scheme

Use the part number scheme for product identification only.

Do not use it for the order process because not all features can always be combined among each other.

NOTE

- Mating connectors are **not** included in the package of a standard drive.
- Mating connectors are included when the drive is ordered with accessories (append “-A” to the model number).
- Mating connectors X1, X2, RJ25, RJ45, SubD are always part of the used cables.

AKD2G - S P E - 7V 06 D - A 3 F3 - 0000 - A

Family

AKD2G AKD 2nd generation

Format

S Servo IP20

Drive Version

P Position Indexer with motion tasks

Connectivity Option

- N Analog
- E EtherCAT®
- C CANopen®
- P PROFINET® IRT
- I Ethernet/IP™

Voltage

- 6V 120/240 V_{ac} 1Ø/3Ø
- 7V 240/480 V_{ac} 3Ø

Current Rating

- 03 3 A_{rms}
- 06 6 A_{rms}
- 12 12 A_{rms}
- 24 24 A_{rms}

Options

- S Single Axis
- D Dual Axis

Connectors

A with connectors (except X1/X2 and X23)

Customization

- 0000 Standard
- A000 Coated PCBs
- C000 Non-Standard

Connector Options*

	Single Axis	Dual Axis
00	X4, X5, X21, X22 Standard	X21, X22 Standard
F3	+X23	+X23
IO	-	-
DX	-	-

Functional Safety (FS)

3 STO, SS1-t, SS1-r, SS2, SBC, SBT, SDB, SLS, SDI, SCA, SSR, SSM, SLA, SLI, SLP, SAR, safe I/O, FSoE SIL3/PLe

Platform Revision

A MAP Revision A

***See connector options feedback, I/O, and brake availability on the following page.**

Example AKD2G-SPE-7V06D-A3F3-0000

AKD2G IP20 housing, position indexer, EtherCAT, 240 V to 480 V mains supply, 2 x 6 A rated current, dual axis, Platform Revision A, Safe Motion Functionality SIL3 PLe with FSoE, with all possible connectors (X21, X22, X23), uncoated, no mating connectors.

Example AKD2G-SPE-6V03S-A3F3-A000-A

AKD2G IP20 housing, position indexer, EtherCAT, 120 V to 240 V mains supply, 3 A rated current, single axis, Platform Revision A, Safe Motion Functionality SIL3 PLe with FSoE, with all possible connectors (X21, X22, X4, X5, X23), PCBs coated, with mating connectors.

4.3.0.1 Connector Options Availability

Connector Options – Feedback Availability	X1, X2 or X5 + SFA Cable ①							
	X1	X2	X5	X21	X22	X23	SFA-ROO	SFA-E00
HIPERFACE DSL	✓	✓	✓					
SFD						✓		✓
SFD3	✓	✓	✓					
Resolver						✓	✓	
BiSS B (Analog)/C (Digital)					C only	✓		✓
EnDAT 2.1(Analog)/2.2 (Digital)					2.2 only	✓		✓
HIPERFACE						✓		✓
Sin/Cos						✓		✓
Sin/Cos +Hall						✓		✓
Incr. Encoder				✓	✓	✓		✓
Incr. Encoder +Hall						✓		✓
Hall						✓		✓
SSI					✓	✓		✓
Step/Direction				✓	✓	✓		
CW/CCW				✓	✓	✓		

Connector Options – I/O Availability

	X21	X22	
Analog-In (AIN)	1 Differential input channel		
Analog-Out (AOUT)	1 Channel		
Digital-In (DIN)	8 Channels Total 2 IEEE EN61131-2 Standard, Fast, Differential Input Channels	4 IEEE EN61131-2 Standard Channels	
Digital-Out (DOUT)	1 channel (relay) + FS1 only 4 Standard DOUT	4 Channels – 2 Fast Channels (Volt Free)	
Digital In/Out (DIO)	-	2 RS-485/Single-Ended Channels	
Encoder Emulation Output ②	-	EEO2	
Electronic Gearing Input	✓	✓	
STO	FS1 Axis 1	FS1 Axis 2	
Safety In (SIN)	2 Channels, Slow – FS2, FS3 only	2 Channels, Slow – FS2 & FS3 only	
Safety Out (SOUT)	4 Channels Slow – FS2 & FS3 only	-	
	Digital In/Out (DIO)	Zero Pulse Available	Encoder Emulation Output ②
X23	4 Channels Total		EEO1
SFA ① – X41 via X1	2 Differential/Single-ended input channels	✓	EEO3
SFA ① – X41 via X2 or X5	2 Single-ended input channels		EEO4

Connector Options – Secondary Brake Availability: X4 only

① The SFA (Smart Feedback Adapter) is optional and supplied separately.

② WorkBench configuration

5 Technical description and data

5.1 The AKD2G Family of Digital Drives	41
5.2 Ambient Conditions, Ventilation and Mounting Position	43
5.3 Mechanical Data	43
5.4 Performance Data	43
5.5 Electrical data	44
5.6 Electrical Motor Braking	49
5.7 LCD Display and Push-buttons (B1, B2)	51
5.8 Rotary Switches (S1, S2)	54
5.9 SD Card Slot	55

5.1 The AKD2G Family of Digital Drives

Available AKD2G-SP (Position Indexer) versions

Connectivity	Rated Voltages	Current	Axis	Rev	Funct. Safety
N- : Analog C- : CANopen E- : EtherCAT P- : PROFINET I- : EtherNet/IP	6V : 120/240VAC 1~ 240VAC 3~ 170/340 VDC 7V : 240/400/480VAC 3~ 340/565/680 VDC	03 : 3 A 06 : 6 A 12 : 12 A 24 : 24 A	S- : Single D- : Dual I1=I2	A	3 : SIL3 extended

Connector Options

Single Axis	Dual Axis
00 : Basis (X21, X22, X4, X5)	00 : Basis (X21, X22)
IO : Basis +X22	
F3 : Basis +X23	F3 : Basis +X23
DX : Basis +X22, +X23	

Standard features

- Single axis or dual axis in one housing
- Supply voltages:
 - DC
 - AC single phase, split phase, three phase AC neutral or leg grounded
 - Single or group supply, single or group mains fusing
- EtherNet Fieldbus on board, TCP/IP service channel and Modbus on board
- SFD3, HIPERFACE DSL motor feedback support on board
- Support for many conventional motor feedback types
- Step / Direction input on board
- Encoder emulation on board
- Use with synchronous servomotors, linear motors, and induction machines

Power section

- Single or three phase AC supply, 5% to 110% of rated AC voltage over 47 to 63 Hz. Connection to higher AC voltage mains only by using isolating transformer.
- DC supply, voltage range 5% to 110% of rated DC voltage. Fusing to be provided by the user.
- Three phase bridge rectifier, integral soft-start circuit.
- DC bus link voltage can be connected in parallel for power sharing.
- Floating current sensors measure actual motor current
- Regenerative circuit with dynamic distribution of the generated power between several drives on the same DC bus link circuit.
- Internal regen resistor for all models, optional external regen resistor if required.

Functional Safety Options

- FS3: STO, SS1-t, SS1-r, SS2, SOS, SLS, SSM, SSR, SDI, SLA, SAR, SLI, SLP, SCA, SBC, SDB, SBT; SIL3 PLe, command by I/O or FSoE (→ # 203).

Electrical safety

- Appropriate insulation / creepage distances and electrical isolation for safe electrical separation, per IEC 61800-5-1, between the power input / motor connections and the signal electronics.
- Soft-start, over voltage detection, short-circuit protection, phase-loss detection.
- Temperature monitoring of the drive and motor.
- Electronic motor overload protection: foldback mechanism or optional fault response.

Auxiliary supply voltage 24VDC

- From an external, safety approved 24 V \pm 10% power supply (PELV).

Parameter setting

- WorkBench Software for setup by using TCP/IP.
- Download control parameter packages by using CoE
- Download safety parameter packages by using FSoE

Full digital control

- Digital current loop (update 1.28 μ s / command 62.5 μ s)
- Digital velocity loop (update period 62.5 μ s)
- Digital position loop (update period 250 μ s)

Inputs/Outputs (X21/X22/X23)

- 2 programmable analog input (\rightarrow # 164)
- 2 programmable analog output (\rightarrow # 166)
- 12 programmable digital inputs (\rightarrow # 166)
- 4 programmable digital outputs (\rightarrow # 171)
- 6 programmable digital input/outputs (\rightarrow # 171)
- 4 programmable safe inputs (\rightarrow # 210)
- 4 programmable safe outputs (\rightarrow # 211)

Connector Options

- **F3:** X23 connector for conventional motor feedbacks (Resolver, SFD, Tamagawa Smart Abs, Comcoder, 1Vp-p Sin-Cos encoders, incremental encoders, EnDAT 2.1/2.2 and HIPERFACE).

Customization

- 0000: uncoated PCBs, standard
0xxx: uncoated PCBs, customized coding
- A000: coated PCBs, standard
Axxx: coated PCBs, customized coding

Connectivity

- Feedback inputs (\rightarrow # 116)
- Encoder emulation output (\rightarrow # 151)
- Digital Inputs/Outputs (\rightarrow # 162)
- Service Interface (\rightarrow # 160)
- Modbus Interface (\rightarrow # 162)
- CANopen (\rightarrow # 158)
- EtherNet Fieldbus interface (\rightarrow # 155)

Accessories

- **SFA** (Smart Feedback Adapter) (\rightarrow # 137).
- Hybrid motor cables, motor power cables, motor feedback cables.

- External regen resistors.

For accessories refer to your regional *Accessories Manual*.

5.2 Ambient Conditions, Ventilation and Mounting Position

Storage, Transport	(→ # 31)
Normal operation	Environmental class 3K3 according to IEC 61800-2
Surrounding temperature in operation	Internal regen resistor used: <ul style="list-style-type: none"> • 0 to +40 °C under rated conditions • +40 to +60 °C with output current derating 3 % per Kelvin Internal regen resistor not used: <ul style="list-style-type: none"> • 0 to +50 °C under rated conditions • +50 to +60 °C with output current derating 2 % per Kelvin
Humidity in operation	Relative humidity 5 to 85%, no condensation, IEC 61800-2 class 3K3
Site altitude	<ul style="list-style-type: none"> • Up to 1,000 m AMSL (above mean sea level): no restriction • 1,000 to 2,000 m AMSL: power derating 1.5%/100 m • Maximum altitude: 2,000 m AMSL
Pollution level	Pollution level 2 as per IEC 60664-1
Vibration	Class 3M1 according to IEC 61800-2
Shock	Class L according to IEC 61800-2
Drive protection	IP 20 according to IEC 60529
Drive EMC immunity	Increased immunity according to EN 61800-5-2
Mounting	Vertical position, in a cabinet with protection of at least IP 54 Minimum cabinet size (WxHxD): 406 x 406 x 254 mm
Ventilation	Built-in fan in all drive variants
NOTICE	The drive shuts down in case of excessively high temperature in the control cabinet. Make sure sufficient forced ventilation is supplied within the control cabinet.

5.3 Mechanical Data

		AKD2G-Sxx-				
	Unit	6V03S, 6V06S, 6V12S	6V03D, 6V06D	7V03S, 7V06S	7V03D, 7V06D, 7V12S	7V24S
Width	mm	76	76	75	75	100
Height, without connectors	mm	235	235	272	272	335
Height, with connectors	mm	303	303	340	340	450
Depth, without connectors	mm	221	221	221	221	274
Depth, with connectors	mm	232	232	232	232	291

NOTE

Dimension Drawing see section Mechanical Installation (→ # 56).

5.4 Performance Data

		AKD2G-Sxx-				
Performance Data	Units	6V03S/D 6V06S/D 6V12S	7V03S/D 7V06S	7V06D	7V12S	7V24S
High/Quiet PWM Switching Frequency (optional setting)(dynamic)	kHz	15.0	11.2	9.8	9.8	9.8

		AKD2G-Sxx-				
Performance Data	Units	6V03S/D 6V06S/D 6V12S	7V03S/D 7V06S	7V06D	7V12S	7V24S
Nominal/High Load PWM Switching Frequency (dynamic)	kHz	10.3	8.1	6.5	5.9	6.5
High Load Stalled PWM Switching Frequency (dynamic)	kHz	5.1	4.1	3.3	2.9	3.3
Max. Voltage rise speed dU/dt	kV/ μ s	7.0	7.0	7.0	7.0	7.0
Current Loop Update Period	μ s	1.28*	1.28*	1.28*	1.28*	1.28*
Velocity Loop Update Period	μ s	62.5	62.5	62.5	62.5	62.5
Position Loop Update Period	μ s	250	250	250	250	250
Max. Current Loop Bandwidth	Hz	3000	2400	1900	1700	1900
Max. Velocity Loop Bandwidth	Hz	750	650	600	550	600
Max. Position Loop Bandwidth	Hz	350	350	350	350	350
Max. Motor Electrical Frequency	Hz	599	599	599	599	599

* Control updates every 1.28 μ s. Current command is updated every 62.5 μ s.

5.5 Electrical data

5.5.1 Single axis variants (S)

5.5.1.1 Mains supply data, 1 phase AC, type AKD2G-Sxx- (S)

Input data	Units	6V03S	6V06S	6V12S
Operational supply voltage (line to line)	VAC	12 to 265		
Rated supply voltage	VAC	100 to 240		
Rated supply input frequency (\pm 5%)	Hz	50 to 60		
Permitted switch on/off frequency	1/h	30		
Rated input VA at 240 V	kVA	1.0	1.7	3.1
Rated input current	A	4.0	7.1	13
Max. inrush current	A	10		
Rated DC bus link voltage	VDC	300		

5.5.1.2 Mains supply data, 3 phase AC, type AKD2G-Sxx- (S)

Input data	Units	6V03S	6V06S	6V12S	7V03S	7V06S	7V12S	7V24S
Operational supply voltage (Line to Line)	VAC	12 to 265			24 to 525			
Rated supply voltage	VAC	100 to 240			200 to 480			
Rated supply input frequency (\pm 5%)	Hz	50 to 60						
Permitted switch on/off frequency	1/h	30						
Rated input VA at 240 V (* at 480 V)	kVA	1.3	2.2	4.0	2.7*	4.4*	7.2*	15.2*
Rated input current	A	3.2	5.3	9.7	3.2	5.3	8.7	18.3
Max. inrush current	A	10						
Rated DC bus link voltage	VDC	140 to 340			280 to 680			

5.5.1.3 Mains supply data, DC, type AKD2G-Sxx- (S)

Input data	Units	6V03S	6V06S	6V12S	7V03S	7V06S	7V12S	7V24S
Operational supply voltage (DC+ to DC-)	VDC	17 to 370			34 to 740			
Rated supply voltage	VDC	100 to 340			200 to 680			
Permitted switch on/off frequency	1/h	30						
Rated input power at 340 V (* at 680 V)	kW	0.62	1.25	2.5	1.25*	2.5*	5.0*	10*
Rated input current	A	2.0	4.0	8.0	2.0	4.0	8.0	16
Max. inrush current through AC input	A	10						
Rated DC bus link voltage	VDC	100 to 340			200 to 680			

5.5.1.4 Output data, type AKD2G-Sxx- (S)

	Units	6V03S	6V06S	6V12S	7V03S	7V06S	7V12S	7V24S	
Continuous output current (± 3%)	Arms	3	6	12	3	6	12	24	
Peak output current (for 5s, ±3%)	Arms	9	18	30	9	18	30	72	
Continuous motor shaft output power at rated input current									
at 1 x 120 VAC	kW	0.22	0.44	0.875	-	-	-	-	
at 1 x 240 VAC	kW	0.44	0.875	1.8				2.5	
at 3 x 120 VAC	kW	0.31	0.625	1.25	-	-	-	-	
at 3 x 240 VAC	kW	0.625	1.25	2.5	0.625	1.25	2.5	5.0	
at 3 x 400 VAC	kW	-	-	-	1.05	2.1	4.2	8.3	
at 3 x 480 VAC	kW	-	-	-	1.25	2.5	5.0	10.0	
at 170 VDC	kW	0.31	0.625	1.25	-	-	-	-	
at 340 VDC	kW	0.625	1.25	2.5	0.625	1.25	2.5	5.0	
at 565 VDC	kW	-	-	-	1.05	2.1	4.2	8.3	
at 680 VDC	kW	-	-	-	1.25	2.5	5.0	10.0	
Peak output power (for 1 s)									
at 1 x 120 VAC	kW	1.1	2.1	4.1	-	-	-	-	
at 1 x 240 VAC	kW	2.1	4.2	6.3	-	-	-	12	
at 3 x 120 VAC	kW	1.5	3	4.5	-	-	-	-	
at 3 x 240 VAC	kW	3.0	6.0	9.0	3.0	6.0	10	24	
at 3 x 400 VAC	kW	-	-	-	5.0	10	16.5	40	
at 3 x 480 VAC	kW	-	-	-	6.0	12	20	48	
at 170 VDC	kW	1.5	3	4.5	-	-	-	-	
at 340 VDC	kW	3.0	6.0	9.0	3.0	6.0	10	24	
at 565 VDC	kW	-	-	-	5.0	10	16.5	40	
at 680 VDC	kW	-	-	-	6.0	12	20	48	
Fan noise emission at 1m, min/max	dB(A)	< 50 / 60						< 50 / 76	
Thermal dissipation, disabled	W	12	12	12	12	12	12	15	
Thermal dissipation at rated current	W	50	80	140	65	105	210	395	
Motor inductance									
minimum at 120 VAC	mH	1.2	0.6	0.3	-	-	-	-	
minimum at 240 VAC	mH	2.4	1.2	0.6	3.1	1.5	1.1	0.5	
minimum at 400 VAC	mH	-	-	-	5.1	2.6	1.8	0.85	
minimum at 480 VAC	mH	-	-	-	6.1	3.1	2.1	1.0	
maximum	mH	240	120	60	610	310	180	80	
Regeneration Braking		(→ # 49)							
Brake output									
Voltage (±10%)	VDC	24							
Voltage power saving	VDC	12 to 24							
Output under current fault	mA	100 (required for fault detection)							
Output over current fault	A	2.25 (required for fault detection)							
Output current, maximum	A	2.1							

5.5.2 Dual axis variants (D: I1=I2)

5.5.2.1 Mains supply data, 1 phase AC, type AKD2G-Sxx- (D)

Input data	Units	6V03D	6V06D
Operational supply voltage (line to line)	VAC	12 to 265	
Rated supply voltage	VAC	100 to 240	
Rated supply input frequency ($\pm 5\%$)	Hz	50 to 60	
Permitted switch on/off frequency	1/h	30	
Rated input VA at 240 V	kVA	1.7	3.1
Rated input current	A	7.2	13
Max. inrush current	A	10	
Rated DC bus link voltage	VDC	140 to 340	

5.5.2.2 Mains supply data, 3 phase AC, type AKD2G-Sxx- (D)

Input data	Units	6V03D	6V06D	7V03D	7V06D
Operational supply voltage (line to line)	VAC	12 to 265		24 to 525	
Rated supply voltage	VAC	100 to 240		200 to 480	
Rated supply input frequency ($\pm 5\%$)	Hz	50 to 60			
Permitted switch on/off frequency	1/h	30			
Rated input VA at 240 V (* at 480 V)	kVA	2.2	4.0	4.4*	7.2*
Rated input current	A	5.3	9.7	5.3	8.7
Max. inrush current (at 240 V/480 V, 20°C)	A	10			
Rated DC bus link voltage	VDC	140 to 340		280 to 680	

5.5.2.3 Mains supply data, DC, type AKD2G-Sxx- (D)

Input data	Units	6V03D	6V06D	7V03D	7V06D
Operational supply voltage (DC+ to DC-)	VDC	17 to 370		34 to 740	
Rated supply voltage	VDC	140 to 340		280 to 680	
Permitted switch on/off frequency	1/h	30			
Rated input power at 340 V (* at 680 V)	kW	1.25	2.5	2.5*	5*
Rated input current	A	4	8	4	8
Max. inrush current through AC input	A	10			
Rated DC bus link voltage	VDC	140 to 340		200 to 680	

5.5.2.4 Output data, type AKD2G-Sxx- (D)

Drive current and power output values are listed for Axis1/Axis2.

Parameter	Units	6V03D	6V06D	7V03D	7V06D
Continuous output current (± 3%)	Arms	3/3	6/6	3/3	6/6
Peak output current (for 5s, ±3%)	Arms	9/9	18/18	9/9	18/18
Continuous motor shaft output power at rated input current					
at 1 x 120 VAC	kW	0.22/0.22	0.44/0.44	-	-
at 1 x 240 VAC	kW	0.44/0.44	0.875/0.875		
at 3 x 120 VAC	kW	0.31/0.31	0.625/0.625	-	-
at 3 x 240 VAC	kW	0.625/0.625	1.25/1.25	0.625/0.625	1.25/1.25
at 3 x 400 VAC	kW	-	-	1.05/1.05	2.1/2.1
at 3 x 480 VAC	kW	-	-	1.25/1.25	2.5/2.5
at 170 VDC	kW	0.31/0.31	0.625/0.625	-	-
at 340 VDC	kW	0.625/0.625	1.25/1.25	0.625/0.625	1.25/1.25
at 565 VDC	kW	-	-	1.05/1.05	2.1/2.1
at 680 VDC	kW	-	-	1.25/1.25	2.5/2.5
Peak output power (for 1 s)					
at 1 x 120 VAC	kW	1.1/1.1	2.1/2.1	-	-
at 1 x 240 VAC	kW	2.1/2.1	4.2/4.2	-	-
at 3 x 120 VAC	kW	1.5/1.5	3.0/3.0	-	-
at 3 x 240 VAC	kW	3.0/3.0	6.0/6.0	3.0/3.0	6.0/6.0
at 3 x 400 VAC	kW	-	-	5.0/5.0	10/10
at 3 x 480 VAC	kW	-	-	6.0/6.0	12/12
at 170 VDC	kW	1.5/1.5	3.0/3.0	-	-
at 340 VDC	kW	3.0/3.0	6.0/6.0	3.0/3.0	6.0/6.0
at 565 VDC	kW	-	-	5.0/5.0	10/10
at 680 VDC	kW	-	-	6.0/6.0	12/12
Fan noise emission at 1m, min/max	dB(A)	< 50 / 60			
Thermal dissipation, disabled	W	15	15	15	15
Thermal dissipation at rated current	W	90	150	120	210
Motor inductance					
minimum at 120 VAC	mH	1.2/1.2	0.6/0.6	-	-
minimum at 240 VAC	mH	2.4/2.4	1.2/1.2	3.1/3.1	1.9/1.9
minimum at 400 VAC	mH	-	-	5.1/5.1	3.2/3.2
minimum at 480 VAC	mH	-	-	6.1/6.1	3.8/3.8
maximum	mH	240/240	120/120	610/610	380/380
Regeneration Braking		(→ # 49)			
Brake output					
Voltage (±10%)	VDC	24			
Voltage power saving	VDC	12 to 24			
Output under current fault	mA	100 (required for fault detection)			
Output over current fault	A	2.25 (required for fault detection)			
Output current, maximum	A	2.1 per brake			

5.5.3 Steady State Control Current per Brake Option

Auxiliary 24 VDC ($\pm 10\%$, check voltage drop) Supply Voltage (PELV)	Units	Current
Base current for all AKD2G Sxx-xV 3-12 A drives with NO brake	A	< 1
Base current for an AKD2G Sxx-7V24S drive with NO brake	A	< 1.5
Additional current load per brake (maximum 2 brakes)*	A	< 1.8

* To calculate current for a drive plus a brake, add base drive current plus the current value for each brake.

For example:

1. AKD2G-Sxx-6V06D with two brakes: Net 24 V current $< 1 + 2 \cdot (1.8) = 4.6$ A
2. AKD2G-Sxx-7V24S with one brake: Net 24 V current $< 1.5 + 1.8 = 3.3$ A

5.6 Electrical Motor Braking

5.6.1 Drive dynamic braking

Drive Dynamic braking is a method to slow down a servo system by dissipating the mechanical energy driven by the motor back EMF.

NOTE

Drive dynamic braking is not functional safe. Safe dynamic braking (SDB) requires an external SDB-Contactor (\rightarrow # 255).

The AKD2G has a built in advanced drive dynamic braking mode which operates fully in hardware. When activated, the drive powers the motor terminals with voltages to maximize the stopping force per amount of motor current. This advanced method forces all of the dynamic braking current to be stopping current and insures the fastest stopping per ampere of motor terminal current.

- When current is not being limited, the mechanical energy is being dissipated in the motor winding resistance.
- When current is being limited, energy is returned to the drive bus capacitors.
- The drive also limits the maximum dynamic braking motor terminal current by using the *AXIS#.DBLIMIT* parameter to insure that the drive, motor, and customer load do not see excessive currents/forces.

Whether and how the AKD2G uses dynamic drive braking depends on *AXIS#.DISMODE*.

5.6.2 Regeneration braking

When the amount of returned energy from the motor builds the bus capacitor voltage up enough the drive activates the regenerative braking circuit to start dumping the returned energy in the regen resistor (also called regenerative resistor or brake resistor). All AKD2G offer internal resistor plus the ability to connect an external resistor depending on the application requirements.

NOTE

External regen resistors are described in the regional *Accessories Manual*.

5.6.2.1 Functional description

1. Individual drives, not coupled through the DC bus link circuit (+DC, -DC)

When the energy fed back from the motor has an average or peak power that exceeds the preset level for the brake power rating, the drive generates the warning "W2010 Regen Energy Critical". If the power exceeds the set fault level, the regenerative circuit will switch off and the drive will disable.

2. Several drives coupled through the DC bus link (+DC, -DC)

Using the built-in regenerative circuit, several drives of the same series can be operated from a common DC-bus link (\rightarrow # 103), without any additional measures. 90% of the combined power of all the coupled drives is always available for peak and continuous power. If the power of the drive with the lowest switch-off threshold (resulting from tolerances) exceeds the set fault level, the regenerative circuit will switch off on that drive.

Switch-off on over voltage: With the regenerative circuit switched off, the returned energy is not dissipated and therefore the DC-bus link level increases. The drive reports an over-voltage fault if the DC-bus voltage threshold is

exceeded. When this happens, the drive power stage is immediately disabled and the load coasts to a stop with the fault message "F2006 Bus Over voltage".

The ready to operate contact (terminals X21/B5-B6) is opened (→ # 175).

NOTE

Observe the regeneration time (some minutes) after full load with peak brake power.

5.6.2.2 Technical data AKD2G-Sxx-6V

Technical data for the regenerative circuit depends on the drive type and the mains voltage. Supply voltages, capacitance, and switch-on voltages are all nominal values.

Brake circuit		AC Supply	
AKD2G-Sxx-	Rated data	Units	120V / 240V
6Vxxy all types	Regen start voltage at rated supply voltage	V	380
	Overvoltage limit	V	420
	Maximum regenerative duty cycle	%	35*
	Internal regen resistor	Ω	15
	Continuous power, internal resistor	W	100
	Peak brake power, internal resistor (0.5s)	kW	3 / 9
	External regen resistor (recommended 15 Ω)	Ω	≥10
	Continuous brake power, external resistor	kW	3
	Peak brake power, external (1s)	kW	5 / 14
6V03S, 6V06S	Absorption energy in capacitors (±20%)	Ws	6 / 23
	DC Bus Capacitance	μF	1640
6V12S, 6V03D, 6V06D	Absorption energy in capacitors (± 20%)	Ws	9 / 35
	DC Bus Capacitance	μF	2460

* depends on connected regen resistor power.

5.6.2.3 Technical data for AKD2G-Sxx-7V

Technical data for the regenerative circuit depends on the drive type and the mains voltage. Supply voltages, capacitance, and switch-on voltages are all nominal values.

Brake circuit		AC Supply		
AKD2G-Sxx-	Rated data	Units	240V	400V/480V
7V03S ,7V06S, 7V12S, 7V03D, 7V06D	Regen start voltage at rated supply voltage	V	380	633 / 760
	Overvoltage limit	V	420	840
	Maximum regenerative duty cycle	%	35*	
	Internal regen resistor	Ω	33	
	Continuous power, internal resistor	W	100	
	Peak brake power, internal resistor (0.5s)	kW	4	17
	External regen resistor (recommended 33 Ω)	Ω	≥25	
	Continuous brake power, external resistor	kW	2	6
	Peak brake power, external (1s)	kW	6	24
7V03S, 7V06S	Absorption energy in capacitors (±20%)	Ws	3	30 / 18
	DC Bus Capacitance	μF	235	
7V12S, 7V03D, 7V06D	Absorption energy in capacitors (±20%)	Ws	6	50 / 35
	DC Bus Capacitance	μF	470	

AKD2G-Sxx-7V24

Brake circuit		AC Supply		
AKD2G-Sxx-	Rated data	Units	240V	400V/480V
7V24S	Regen start voltage at rated supply voltage	V	380	633 / 760
	Overvoltage limit	V	420	840
	Maximum regenerative duty cycle	%	35*	
	Internal regen resistor	Ω	15	
	Continuous power, internal resistor	W	140	
	Peak brake power, internal resistor (0.5s)	kW	9	38
	External regen resistor (recommended 15 Ω)	Ω	≥10	
	Continuous brake power, external resistor	kW	3	10
	Peak brake power, external (1s)	kW	14	55
	Absorption energy in capacitors (±20%)	Ws	15	125 / 80
	DC Bus Capacitance	μF	1200	

* depends on connected regen resistor power.

5.7 LCD Display and Push-buttons (B1, B2)

The drive offers an LCD display and two push-buttons B1 / B2 for navigation.

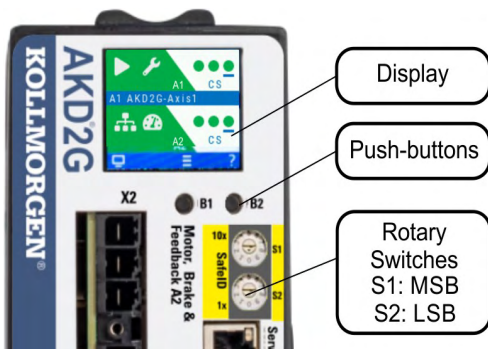

Push-button actions

A short button press invokes the action corresponding to the symbol directly above the button. On the dashboard for example,

- a short press on B1 causes the menu system to appear, and
- a short press on B2 causes a help screen to appear.
- A long press (greater than 2 seconds) on B2 returns the display to the previous screen.

B1 / B2 Functions	Description
Boot from SD card	Push both buttons during power up to boot with data from SD card. Press the buttons first, then hold it down while turning on the 24 V power supply.
Boot from flash fallback image	Remove the SD card, then press both buttons and hold them down while turning on the 24 V power supply to boot from an on-board recovery image. The fallback image includes a set of bootloader, operational, and control FPGA that implements sufficient programming support to update missing or corrupt files.
SafeID Validation	Push B2 to acknowledge SafeID validation request on the display.

LCD display

- Left Colored section
 - Color: axis status (enabled, disabled, or faulted).
 - First icon: axis command source (analog, service, electronic gearing, or fieldbus).
 - Second icon: axis operation mode (torque, velocity, or position).
 - Axis ID: A1 or A2.
- Right Non-colored section:
 - No Fault/Warning: three virtual LEDs corresponding to axis disable sources (Safe Torque Off, Hardware Enable, and Controlled Stop).
 - Faults or warnings: fault or warning code.
- Center blue bar:
 - Drive and axis names
 - IP address
 - Drive model number
 - Firmware version
- Bottom blue bar:
 - indicates whether the service port is connected to WorkBench, and
 - shows the actions that will be invoked by pushing the B1 / B2 buttons.

Dual axis LCD display

For dual-axis drives, the top section shows axis 1 information, the bottom section those for axis 2.

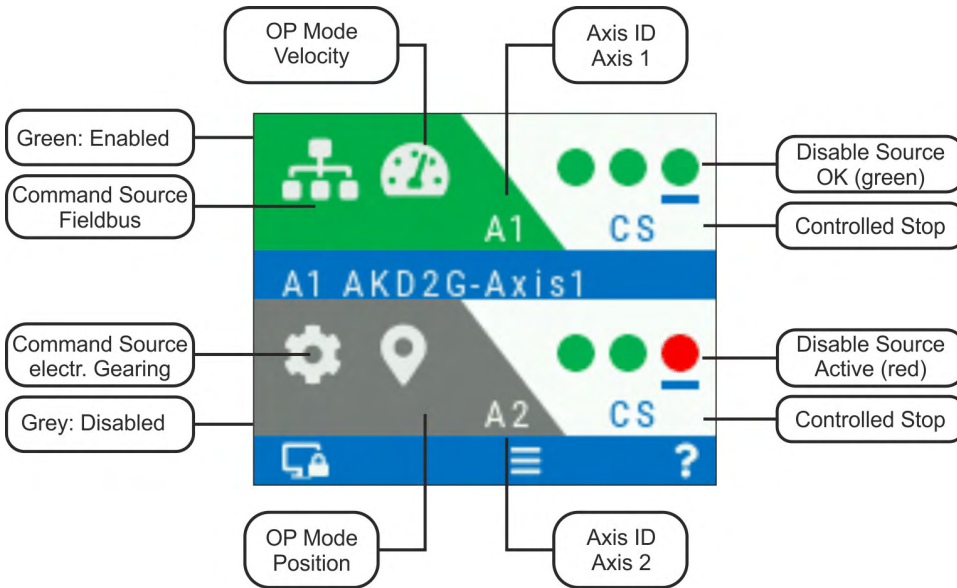

Single axis LCD display

For single axis drives, the top section shows axis 1 information while the section between the center and bottom bars is a data area where some important actual values of the axis are visible: position, velocity, current.

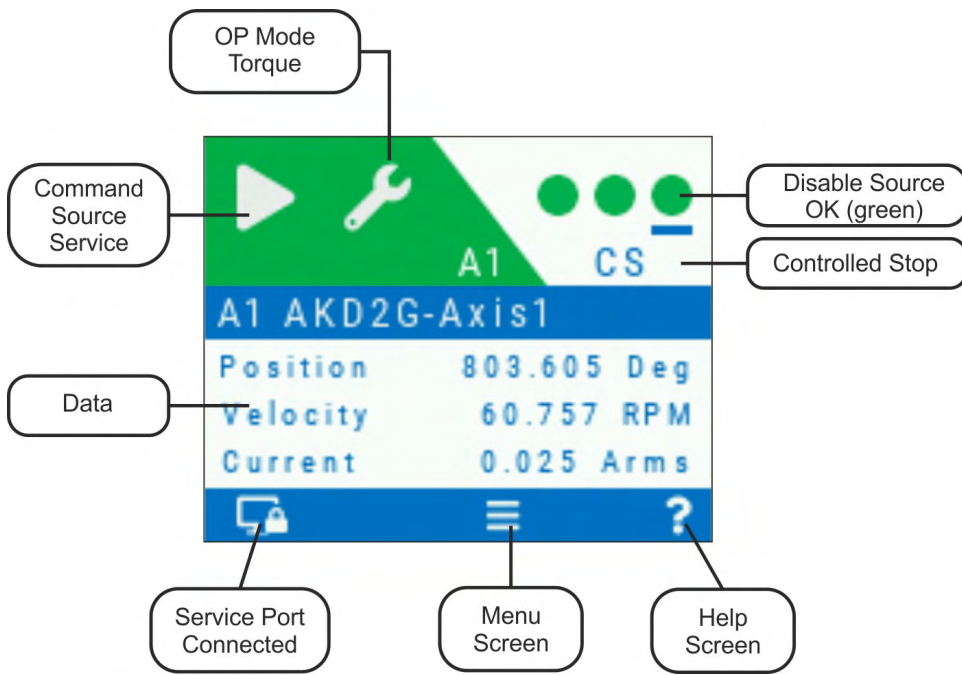

Faults and Warnings

The display shows the code of the fault or warning that occurred. If a fault occurs, the color of the left section switches to red. Navigate with B1 / B2 to the Fault screen to see a short description of the fault or warning.

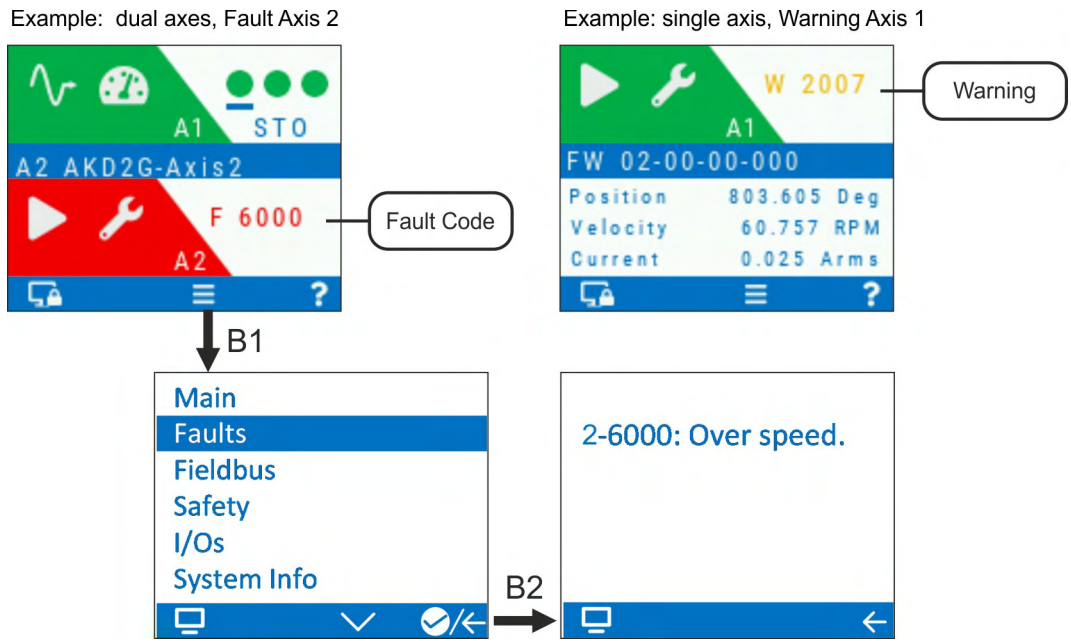

See WorkBench Onlinehelp for more details.

5.8 Rotary Switches (S1, S2)

AKD2G with safety option 3 offer two decimal rotary switches for setting the SafeID and FSoE node address.

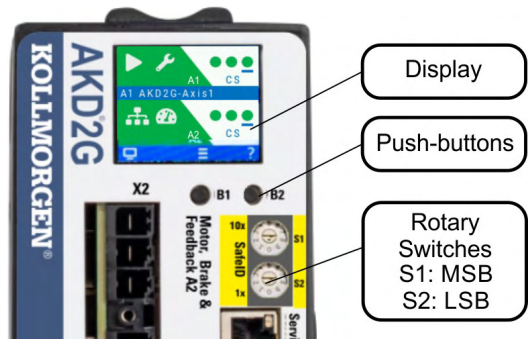

Refer to section "Functional Safety" for complete information (→ # 288).

5.9 SD Card Slot

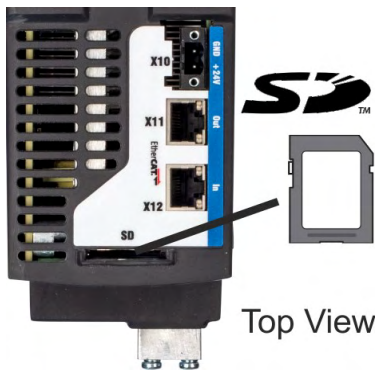

AKD2G contains an SD card slot

- to recover the drive from failure and
- to backup and restore firmware and parameters and
- to store AKD2G logs.

These features can be accessed from the drive display using push-buttons B1/B2.

Supported SD card types

SD cards are formatted by the manufacturer. The following table outlines the SD card types and AKD2G support.

SD Type	File System	Capacity	Supported
SD (SDSC)	FAT16	1MB to 2GB	YES
SDHC	FAT32	4GB to 32GB	YES
SDXC	exFAT (Microsoft)	>32GB to 2TB	NO

Features

Refer to the WorkBench online help for complete information.

- **To recover AKD2G from an SD card:**
Remove 24V. Press the buttons B1 and B2 to apply 24V. Release buttons after the display is updated.
- **Backup/Restore operations:**
Only possible when no program is running and the drive is disabled.
Note that if a fault occurs during Backup/Restore operations, the fault number shows up in the display, error codes (→ # 191).
 - Drive Firmware Backup/Restore
 - Drive Parameters Save/Restore
 - Storing drive logs
 - Storing drive troubleshooting information in case of failure.
 - Drive recovery in case of failure.

6 Mechanical Installation

6.1 Important Notes	57
6.2 Guide to Mechanical Installation	57
6.3 Dimensions	57

6.1 Important Notes



CAUTION High EMC Voltage Level!

Risk of electrical shock, if the servo amplifier (or the motor) is not properly EMC-grounded.

- Use electrically conductive mounting plates, e. g. made of aluminum or galvanized steel.
- In unfavourable circumstances, use copper mesh tape between the earthing bolts and earth potential to deflect currents.



WARNING Projection of molten particles!

If particles fall into the drive or the drive has been damaged, molten drive component particles may be ejected causing injuries. Shut down the drive and wear appropriate protective gear during maintenance work, troubleshooting and fault rectification.(→ # 34)

NOTICE

Protect the drive from impermissible stresses. In particular, do not let any components become bent or any insulation distances altered during transport and handling. Avoid contact with electronic components and contacts.

6.2 Guide to Mechanical Installation

You need at least the following tools to install the AKD2G:

- M5 hexagon socket-cap screws (ISO 4762)
- 4 mm hexagon ball head screwdriver
- No. 2 Phillips head screwdriver
- Small slotted screwdriver

Your specific installation may require additional tools.

NOTICE

Do not mount the drive right next to devices that produce magnetic fields. Strong magnetic fields can directly affect internal components. Install the drive with distance to such devices and/or shield the magnetic fields.

Install the drive unit as follows:

1. Mount the drive in a closed control cabinet (ambient conditions (→ # 43). The site must be free from conductive or corrosive materials. For the mounting position in the cabinet see (→ # 57).
2. Check that the ventilation of the drive is unimpeded and keep within the permitted ambient temperature (→ # 43). Keep the required space clearance above and below the drive (→ # 57).
3. Ensure that there is an adequate flow of cool, filtered air into the bottom of the control cabinet, or use a heat exchanger (→ # 43).
Notice: The drive will switch itself off in case of overheating.
4. If you are using a cooling system for the control cabinet, position the cooling system in a way that condensation water cannot drip onto the drive or peripheral devices.
5. Assemble the drive and power supply next to each other on the conductive, grounded mounting plate in the cabinet.
6. Ground the mounting plate, motor housing and CNC-GND of the control system. For EMC-compliant shielding and grounding see (→ # 66).

6.3 Dimensions

NOTE

Mounting: 3 x M5 hexagon socket screws to ISO 4762, 4 mm hexagon ball head screwdriver

Parameter	Unit	AKD2G-Sxx-				
		6V03S, 6V06S, 6V12S	6V03D, 6V06D	7V03S, 7V06S	7V03D, 7V06D, 7V12S	7V24S
Weight (without mating connectors)	kg	2.4	2.5	2.5	2.7	6.4

General 6V and 7V models with X3 connector

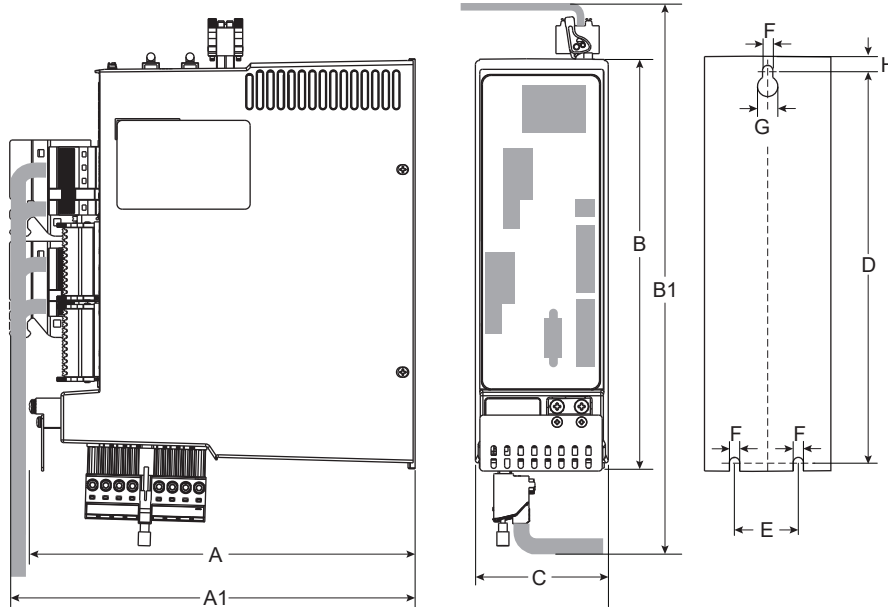

7V24S model with X3A and X3B connectors

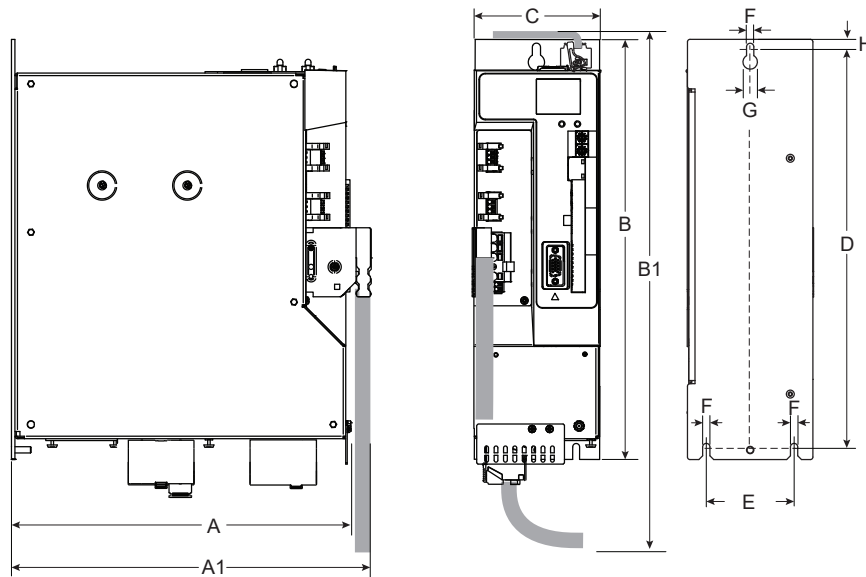

NOTE

Outline width and height dimensions are measured on footprint level (mounting plate). Dimensions on the front plate are slightly smaller.

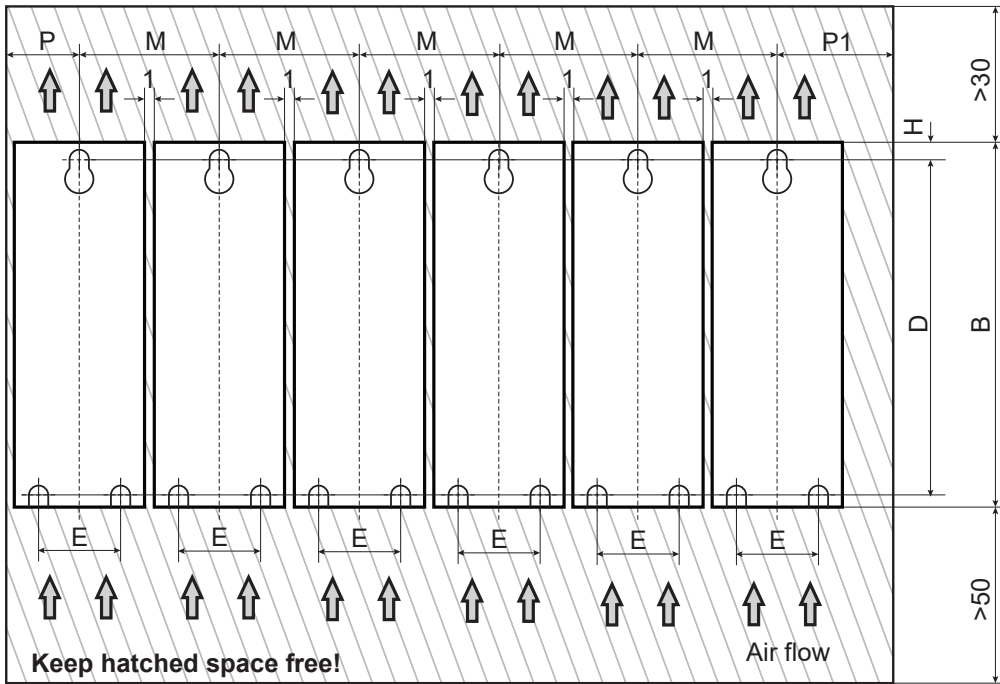

Model	Unit	A	A1	B	B1	C	D	E	F	G	H	M	P	P1
AKD2G-Sxx-6V (3 to 12 A)	mm	221	232	235	303	76	221.5	36	5.8	11.5	7	77	40	40
AKD2G-Sxx-7V (3 to 12 A)	mm	221	232	272	340	75	259	36	5.8	11.5	6	76	40	40
AKD2G-Sxx-7V (24 A)	mm	274	291	335	450*	100	319	70	5.8	11.5	6	105	55*	55

*X3A and X3B with bracket option: $P \geq 125$ mm, $B1 \geq 520$ mm.

7 Electrical Installation

7.1 Important Notes	61
7.2 Guide to electrical installation	62
7.3 Wiring	63
7.4 EMI Noise Reduction	66
7.5 Connection Overview	71
7.6 Power and Logic Voltage Supply (X3/X10)	89
7.7 DC Bus link connector X3/X3B	103
7.8 Regen resistor connector X3/X3B	106
7.9 Motor Power, Brake and Feedback connection	107
7.10 Feedback Connection	116
7.11 Gearing	151
7.12 Ethernet Fieldbus Interface Connector X11/X12	155
7.13 CAN-Bus Interface connector X13/X14	158
7.14 Service Interface connector X20	160
7.15 Modbus TCP connector X20	162
7.16 I/O Connectors X21/X22/X23	162

7.1 Important Notes

NOTICE

Only professional staff who are qualified in electrical engineering are allowed to install the drive. Wires with color green with one or more yellow stripes must not be used other than for protective earth (PE) wiring.



DANGER High Voltage up to 900V!

- There is a danger of serious personal injury or death by electrical shock or electrical arcing. Capacitors can still have dangerous voltages present up to 5 minutes after switching off the supply power. Control and power connections can still be live, even if the motor is not rotating.
- Only install and wire the equipment when it is not live.
 - Make sure that the cabinet is safely disconnected (for instance, with a lock-out and warning signs).
 - Never remove electrical connections to the drive while it is live.
 - Wait at least 5 minutes after disconnecting the drive from the main supply power before touching potentially live sections of the equipment (e.g. contacts) or undoing any connections.
 - To be sure, measure the voltage in the DC bus link and wait until it has fallen below 50 V.



WARNING Projection of molten particles!

If particles fall into the drive or the drive has been damaged, molten drive component particles may be ejected causing injuries. Shut down the drive and wear appropriate protective gear during maintenance work, troubleshooting and fault rectification. (→ # 34)

NOTICE

Wrong mains voltage, unsuitable motor or wrong wiring will damage the drive. Check the combination of drive and motor. Compare the rated voltage and current of the units. Implement the wiring according to the matching connection diagram, see (→ # 77) and following. Make sure that the maximum permissible rated voltage at the terminals L1, L2, L3 or +DC, -DC is not exceeded by more than 10% even in the most unfavorable circumstances (see IEC 60204-1).

NOTICE

Excessively high external fusing will endanger cables and devices. The fusing of the mains power and logic power must be installed by the user. Hints for use of Residual-current circuit breakers (RCD) (→ # 26).

NOTICE

Since the leakage current to PE is more than 3.5 mA, in compliance with IEC61800-5-1 the PE connection must either be doubled or a connecting cable with a cross-section >10 mm² must be used. Deviating measures according to regional standards might be possible.

NOTICE

The drive status shall be monitored by the PLC to acknowledge critical situations. We recommend wiring the ready to operate relay contact in series into the emergency off circuit of the installation. The emergency off circuit must operate the supply contactor.

NOTE

It is permissible to use WorkBench to change the settings of the drive. Any other alteration will invalidate the warranty.

7.2 Guide to electrical installation

Kollmorgen recommends to install the drive electrical system as follows:

1. Select cables in accordance with IEC 60204 (→ # 64).
2. Install shielding and ground the drive.
For EMC-compliant shielding and grounding, see (→ # 66).
Ground the mounting plate, motor housing and CNC-GND of the control system.
3. For functional safety information, see (→ # 193).
4. Wire the drive and connectors.
Observe the "Recommendations for EMI noise reduction": (→ # 66).
 - Wire the "Ready to Operate" contact into the emergency off circuit of the system.
 - Connect the digital control inputs and outputs.
 - Connect up analog ground (also if a fieldbus is used).
 - Connect the analog input source, if required.
 - Connect the motor (hybrid cable or power, brake and feedback cables).
 - Connect shielding at both ends.
 - If required, connect the external regen resistor (with fusing).
 - Connect the mains filter FN2090/FN3288 with AKD2G-Sxx-6V (with shielded lines between filter and drive) for second environment requirements to product category C2.
 - Connect the auxiliary voltage supply
 - Connect the main electrical supply.
Check maximum permitted voltage value (→ # 44).
 - Check proper use of residual-current circuit breakers (RCD): (→ # 26).
 - Connect the PC (→ # 160) for setting up the drive.
5. Check the wiring against the wiring diagrams:

Overview AKD2G single axis	(→ # 77)
Overview AKD2G dual-axis	(→ # 79)
Connector pinout	(→ # 79)
Mains power supply:	(→ # 92)
Logic power supply:	(→ # 102)
DC Bus Link:	(→ # 103)
External Regen Resistor:	(→ # 106)
Motor single cable connection:	(→ # 108)
Motor dual cable connection:	(→ # 110)
Motor Holding Brake:	(→ # 113)
Feedback Connection	(→ # 116)
Encoder emulation:	(→ # 151)
Electronic gearing:	(→ # 151)
Master Slave:	(→ # 153)
EtherNet Fieldbus interface:	(→ # 155)
CAN-Bus interface:	(→ # 158)
Service interface:	(→ # 160)
Modbus interface:	(→ # 162)
Digital and analog I/O:	(→ # 162)

7.3 Wiring

NOTICE

Only professional staff who is qualified in electrical engineering are allowed to install the drive. Wires with color green with one or more yellow stripes must not be used other than for protective earth (PE) wiring. When installing or replacing cables, use only standardized components, which comply to the cable and wire requirements (→ # 64).

7.3.1 General



DANGER High Voltage up to 900V!

There is a danger of serious personal injury or death by electrical shock or electrical arcing.

- Only install and wire the equipment when it is not live, that is, when neither the electrical supply nor the 24V auxiliary voltage nor the supply voltages of any other connected equipment is switched on.
- Make sure that the cabinet is safely disconnected (for instance, with a lock-out and warning signs). The individual voltages are switched on for the first time during setup.

NOTE

The chassis ground symbol, which is used in all the wiring diagrams, indicates that you must take care to provide an electrically conductive connection with the largest feasible surface area between the unit indicated and the mounting plate in the control cabinet. This connection is for the effective grounding of HF interference, and must not be confused with the PE-symbol (PE = protective earth, safety measure as per IEC 60204).

7.3.2 Mating connectors

NOTE

- Connectors X1, X2, X4, X5, X10T, X21, X22 are spring clamp connectors.
- X3/X3T connector with screw terminals, tightening torque 0.5...0.6 Nm (4.4...5.3 in-lbs).
- X3A/X3B connector with screw terminals, tightening torque 2 Nm (18 in-lbs).
- Connectors X4, X5, X22 and X23 are optional.

#	Description	Type	Max. Cross Section
X1/2	Motor, two wire feedback, holding brake	Connector, 4 pol. power	10 mm ² , 8 awg
		Connector, 4 pol. signal	0.5 mm ² , 21 awg
X3/X3T	Mains power, regen resistor, DC-Bus	Connector or T-type, 8 pol.	6 mm ² , 10 awg
X3A/X3B	Mains power, regen resistor, DC-Bus	Connector, 4 pol. power	6 mm ² , 10 awg
X4	Second brake	Connector, 3 pol.	1.5 mm ² , 16 awg
X5	Second feedback, two wire	Connector, 3 pol.	1.5 mm ² , 16 awg
X10T	24V power supply	T-type connector, 2 pol.	2.5 mm ² , 14 awg
X11/12	EtherNet Fieldbus	RJ45	0.5 mm ² , 21 awg
X13/14	CAN In/Out	RJ25	0.5 mm ² , 21 awg
X20	Service Port	RJ45	0,5 mm ² , 21 awg
X21	I/O control signals	Connector, 2x11 pol.	1.5 mm ² , 16 awg
X22	I/O control signals	Connector, 2x10 pol.	1.5 mm ² , 16 awg
X23	Conventional feedback models	SubD 15pol. HD (female)	0.5 mm ² , 21 awg

7.3.3 Cable and Wire Requirements

7.3.3.1 Cable material

For information on the chemical, mechanical, and electrical characteristics of the cables please refer to the *Kollmorgen 2G Cable Guide* or contact customer support.

NOTE

To reach the maximum permitted cable length, you have to use cable material with the following capacitance requirements:

- Motor power cable: less than 150 pF/m (phase core to shield capacitance)
- Motor Feedback cable: less than 120 pF/m (signal core to shield capacitance)
- Hybrid motor cable:
 - less than 120 pF/m (phase core/core capacitance)
 - less than 210 pF/m (phase core/shield capacitance)
 - less than 120 pF/m (signal core/core capacitance)
 - less than 210 pF/m (signal core/shield capacitance)
 - BUS Element: 45 pF/m @ 800kHz & charact. wave resistance $110 \pm 10 \Omega$ @ 10MHz

7.3.3.2 Cable length

NOTICE

Cables should not exceed the maximum lengths stated below. The recommended maximum cable length of motor cables depends on the used cable material and the feedback type. Cable functionality is only guaranteed up to the maximum length when using unmodified Kollmorgen engineered cables.

Motor cables (X1, X2, X4, X5, X23, X41)

Length of motor power cables, feedback cables and motor brake cables is equal.

AKM2G		AKM			
Performance Line Cables		Performance Essentials	Cable Line Cables	Value Line Cables	
Feedback	Max. Length [m]	Feedback	Max. Length [m]	Feedback	Max. Length [m]
SFD3	50	All	25	All	12
DSL	25				
Endat 2.2	25				
Resolver	50				

I/O cables (X21, X22)

NOTICE

Maximum distance for unshielded I/O lines is 3m inside the cabinet. If the I/O cable leaves the cabinet, it must be EMC shielded.

7.3.3.3 T-Connector wiring

If you use mating T-connectors for 24 VDC supply, mains voltage supply and DC-Bus link, you have to prepare the connecting cables with wire end ferrules.

You can prepare cables with cross-section 2.5mm² (up to 6mm²) with a uniform length of 170mm, if the modules are lined up close together.

Use wire end ferrules with plastic collars, for example 2.5mm² x 17mm.

7.3.3.4 Cable cross sections and requirements

The tables below describe the recommended interface cross sections and cable requirements related to AKD2G in accordance with IEC 60204. For multi-axes systems, observe the specific operating conditions for your system.

Power Cables		Cross Section		Remarks
		EU	US	
Mains supply	1x3 A:	1.5 mm ²	14 awg	600 V rated ,minimum 75°C
	2x3 A:	1.5 mm ²	14 awg	
	1x6 A:	1.5 mm ²	14 awg	
	2x6 A:	2.5 mm ²	14 awg	
	1x12 A:	2.5 mm ²	14 awg	
	1x24 A:	6 mm ²	10 awg	
24 V supply	max.	2.5 mm ²	14 awg	Single core Flexible Class 5
DC bus link, Regen resistor	3/6 A:	1.5 mm ²	14 awg	1000 V rated, min. 75°C, shielded for lengths >0.20 m
	12 A:	2.5 mm ²	14 awg	
	24 A:	6 mm ²	10 awg	
Analog I/Os	min.	0.25 mm ²	24 awg	shielded twisted pairs
Digital I/Os		0.5 mm ²	20 awg	single core

Motor power cable (power) & motor combination cable (power & brake)

Cross Section [mm]		Current Carrying Capacity	Remarks
Cable	Combi Cable		
(4x1)	(4x1.0+(2x0.75))	0A < I _{rms} ≤ 10.1A	1000 V Rated, 80°C
(4x1.5)	(4x1.5+(2x0.75))	10.1A < I _{rms} ≤ 13.1A	Current carrying capacity acc. to IEC 60204-1:2006 Table 6, Column B2
(4x2.5)	(4x2.5+(2x1.0))	13.1A < I _{rms} ≤ 17.4A	
(4x4)	(4x4.0+(2x1.0))	17.4A < I _{rms} ≤ 23A	The brackets (...) show the shielding.
(4x6)	(4x6.0+(2x1.0))	23A < I _{rms} ≤ 30A	

Motor feedback cable

Type	Cross Section [mm]	Remarks
Resolver	(4x2x0.25)	300 V rated, 80°C
EnDat 2.1, BiSS B	(6x2x0.25)	
HIPERFACE	(5x2x0.25)	Shielded twisted pairs
EnDat 2.2, BiSS C	(5x2x0.25)	The brackets (...) show the shielding.
SFD	(3x2x0.25)	
Comcoder	(8x2x0.25)	

Motor hybrid cable

Type	Cross Section [mm]	Current Carrying Capacity	Remarks
SFD3/DSL	(4x1.0+(2x0.34)+(2x0.75))	0A < I _{rms} ≤ 10.1A	1000 V rated, 80°C
SFD3/DSL	(4x1.5+(2x0.34)+(2x0.75))	10.1A < I _{rms} ≤ 13.1A	Current carrying capacity acc. to IEC 60204-1:2006 Table 6, Column B2
SFD3/DSL	(4x2.5+(2x0.34)+(2x1.0))	13.1A < I _{rms} ≤ 17.4A	
SFD3/DSL	(4x4.0+(2x0.34)+(2x1.0))	17.4A < I _{rms} ≤ 23A	4 power lines & 2 brake lines & 2 SFD3/DSL signal lines
SFD3/DSL	(4x6.0+(2x0.34)+(2x1.0))	23A < I _{rms} ≤ 30A	
Endat 2.2	(4x1.5+(2x0.75)+(2x2x0.14+2x0.25))	10.1A < I _{rms} ≤ 13.1A	or 6 EnDat 2.2 signal lines
Endat 2.2	(4x4.0+(2x1.0)+(2x2x0.14+2x0.25))	17.4A < I _{rms} ≤ 23A	

7.3.4 Protective Earth Connection

Protective Earth connection of the system components is a safety measure per IEC 60204. Ensure the proper grounding of all components with the PE rail in the control cabinet as reference potential. Connect each ground individually with the intended grounding cable (neutral point connection).

The leakage current from AKD2G against PE is more than 3.5 mA. In accordance with EN 61800-5-1, the PE connection must therefore either be double implemented or a connection cable with >10 mm² cross-section used.

In order to keep the impedance as low as possible, we recommend a copper earthing strap for the PE connection on the PE block.

NOTE

Wire the PE connections immediately after installing the devices as the first electrical connection. Now you insert all the other lines and connectors. For disassembly, release the PE connections as the last connection.

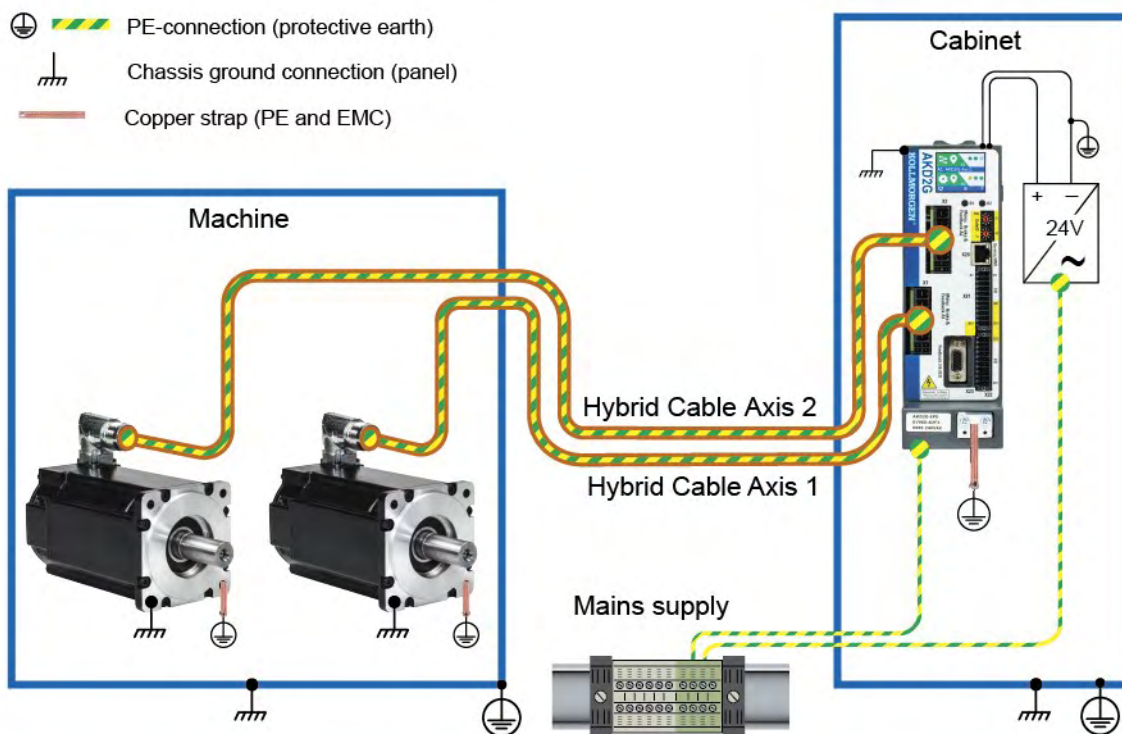

NOTE

For the use of residual current protective devices (RCD), refer to (→ # 26).

7.4 EMI Noise Reduction



CAUTION Electromagnetic Fields!

Electromagnetic radiation may lead to potential hazardous danger (warming, failure of implants), when acting on electrically conductive materials.

- Work on the electrical installation may only be performed by trained and qualified personnel, in compliance with the regulations for safety at work, and only with switched off mains supply and secured against restart.
- Do not remove grounding, equipotential bonding and radiation-reducing shields.

7.4.1 Reducing EMI noise

With the help of the following instructions, you can reduce electrical interference in the application:

- **Ensure good connections between the cabinet components.** Connect the back panel and cabinet door to the cabinet body using several conductive braids. Never rely on hinges or mounting bolts for ground connections.
- **Ensure good ground connection.** Connect from cabinet to proper earth ground. Ground leads should be the same gauge as the leads to main power, but must cover the regional legal requirements, example (→ # 66).
- **Use Kollmorgen cables.** Route power and control cables separately, Kollmorgen recommends a distance of at least 200 mm to improve interference immunity.
- **Ground the shielding at both ends.** Ground all shielding with large areas (low impedance), with metalized connector housings or shield connection clamps wherever possible. For cables entering a cabinet, connect shields on all 360° of the cable. Never connect a simple “pigtail.” For more information on shielding concepts, (→ # 67).
- **With separate mains filter, maintain separation of leads entering and exiting the mains filter (line power filter).** Locate the filter as close as possible to the point where the incoming power enters the cabinet. If it is necessary for input power and motor leads to cross, cross them at 90°.
- **Observe cable length limits.** Maximum distance for unshielded I/O lines is 3 m inside the cabinet. If the I/O cable leaves the cabinet, it must be EMC shielded.
- **Do not extend feedback lines and hybrid cables, since the shielding would be interrupted and the signal processing may be disturbed.** Install all feedback cables with an adequate cross-section, per IEC 60204 (→ # 64) and use the requested cable material to reach maximum cable length.
- **Splice cables properly.** If you need to divide cables, use connectors with metal backshells. Ensure that both shells connect along the full 360° of the shields.
- **Use differential inputs for analog signals.** Noise susceptibility in analog signals is greatly reduced by using differential inputs. Use twisted-pair, shielded signal lines, connecting shields on both ends.
- **Shield cables between drives and filters or external regen resistors.** Install all power cables with an adequate cross-section per IEC 60204 (→ # 64) and use the requested cable material to reach maximum cable length.

7.4.2 Shielding with external shielding busbar

Kollmorgen recommends a star point shield connection, for example, with a shielding busbar.

7.4.2.1 Shielding Concept

Example with AKD2G-Sxx--6Vxx, EMC filter and external regen resistor.

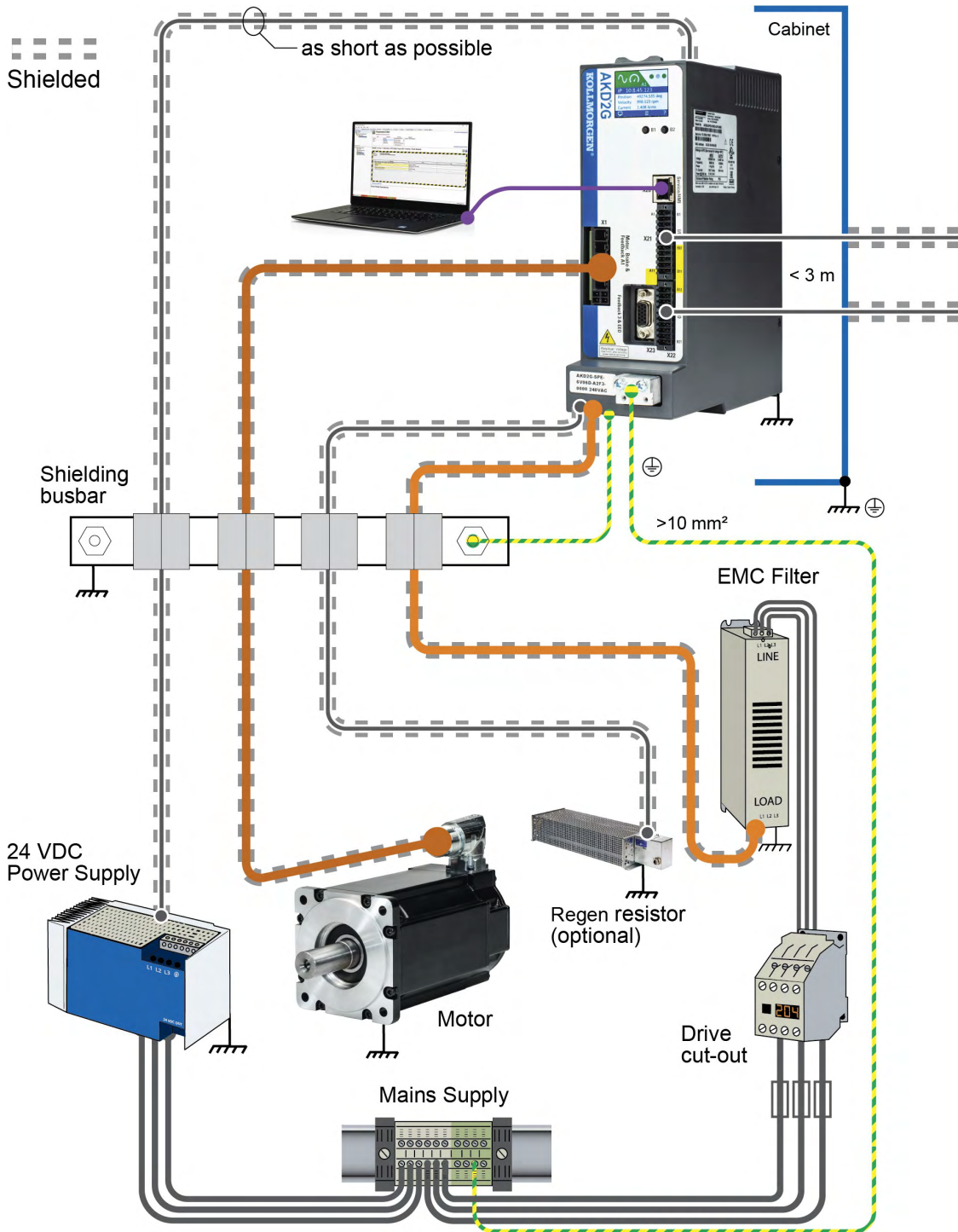

7.4.2.2 Shielding Busbar



The power cable shields (line in, motor cable, external regen resistor) can be routed to an additional busbar via shield clamps.

Kollmorgen recommends using Weidmüller KLBÜ shield clamps.

A possible scenario for setting up a busbar for the above shield clamps is described below.

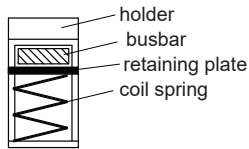
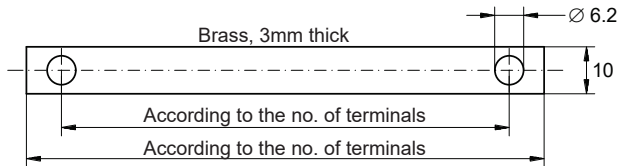

1. Cut a busbar of the required length from a brass rail (cross-section 10 x 3 mm) and drill holes in it as indicated. All shield clamps required must fit between the drill holes.

CAUTION

Risk of injury due to the spring force of the coil spring.
Use pincers.

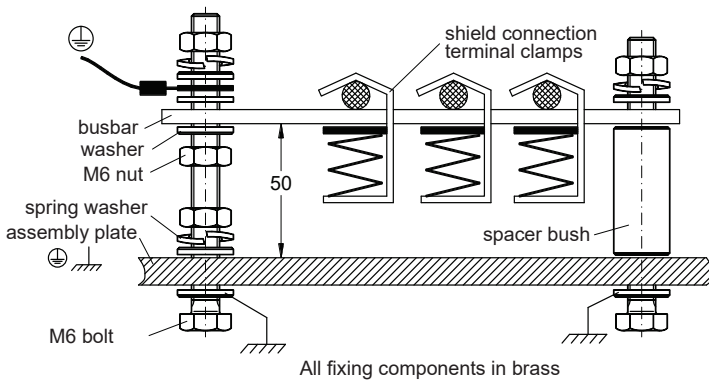

2. Squeeze together the coil spring and the supporting plate and push the busbar through the opening in the holder.
3. Mount the busbar with the shield clamps fitted on the assembly plate. Use either metal spacer bushes or screws with nuts and accessories to maintain a spacing of 50 mm. Earth the busbar using a single conductor with a cross-section of at least 2.5 mm².
4. Strip the external cable sheath to a length of approx. 30 mm, taking care not to damage the braided shield. Push the shield clamp up and route the cable to it via the busbar.

NOTICE

Make sure there is good contact between the shield clamp and the braided shield.

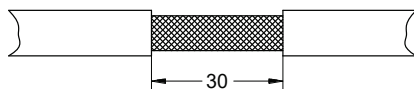

7.4.3 Shielding connection to the drive

You can connect cable shielding directly to the drive by using grounding plates, shield connection clamps, and a motor connector with strain relief and grounding plate.

7.4.3.1 Shielding Concept

Example with AKD2G-Sxx--7Vxx, dual-axis.

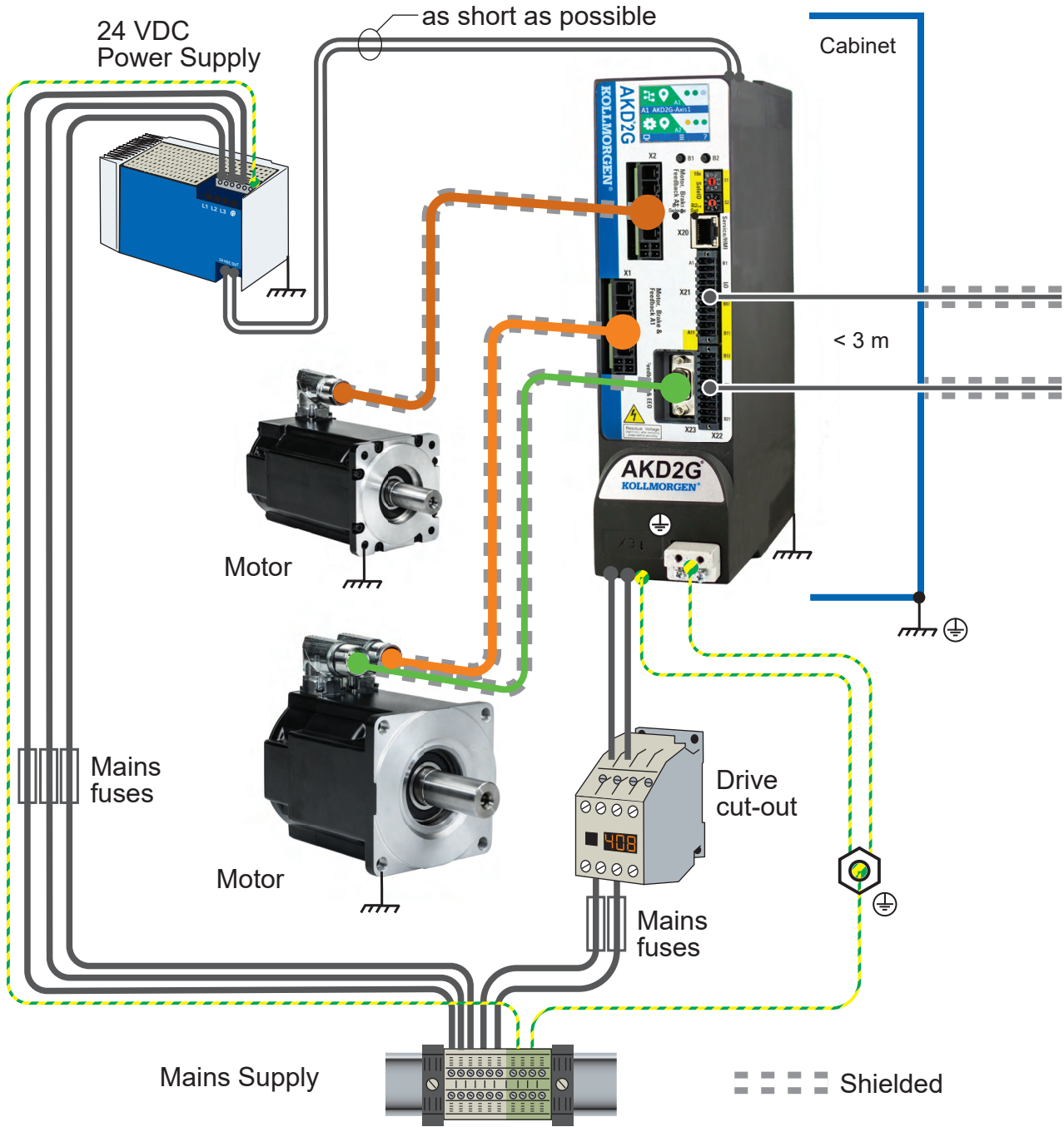

7.4.3.2 Grounding plates and shield connection clamps

A grounding plate is mounted to the drive.



Use shield connection clamps (see accessories manual). These hook into the grounding plate and ensure optimum contact between the shield and the grounding plate.

Kollmorgen recommends using Phoenix Contact SK14 shield clamps with cable clamp range of 6-13mm.

7.4.3.3 Motor connector X1/X2 with shielding connection

Alternative connection of the motor power by mating connector with shield plate and strain relief. Kollmorgen motor power and hybrid motor cables are configured with shield plate.

To connect the motor power, proceed as follows:

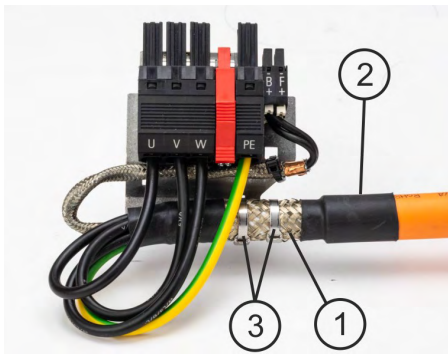

1. Strip the external cable sheath to a length of approx. 80mm, taking care not to damage the braided shield.
2. Push the braided shield (1) back over the cable and secure with a rubber sleeve (2) or shrink sleeve.
3. Shorten all the wires apart from the protective earth (PE) wire (green/yellow) by about 20mm so that the PE wire is now the longest wire.
4. Strip all wires and fit wire end ferrules.
5. Secure the braided shield of the cable with metal cable ties (3) and fasten the cable.
6. Wire the connector as shown in the connection diagram.
7. Plug in the connector to the socket on the front of the AKD2G and secure it with the red clip.

The motor power is now connected.

7.5 Connection Overview

7.5.1 Connector Position AKD2G-Sxx-6VxxS

NOTE

The graphic shows a single axis drive (supply voltage 110 V to 240 V).
Optional: F3 option for additional X23 (→ # 37).

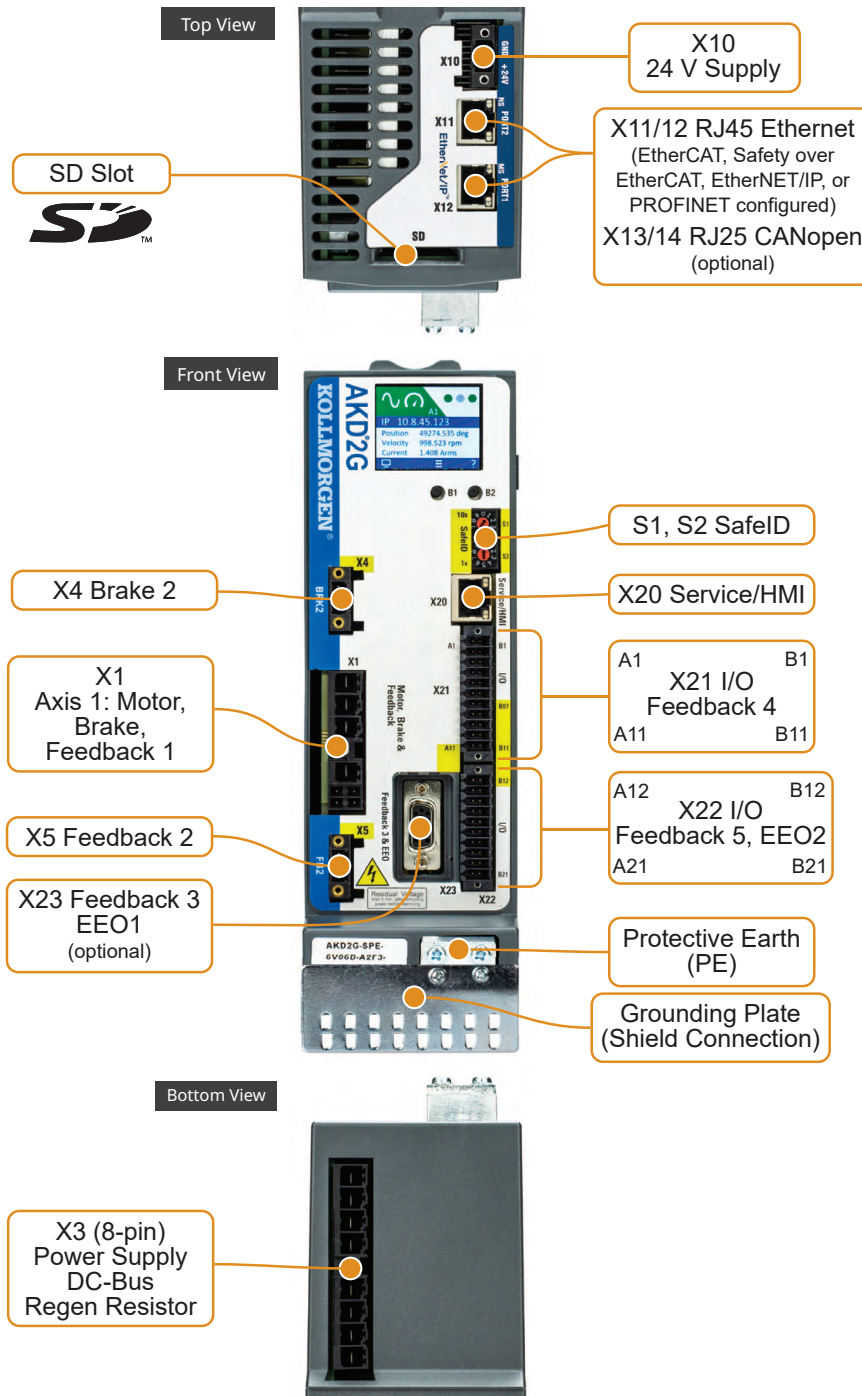

7.5.2 Connector Position AKD2G-Sxx-7VxxS

NOTE

The graphic shows a single axis drive (supply voltage 240 V to 480 V).
Optional: F3 option for additional X23 (→ # 37).

7.5.2.1 AKD2G 480 Vac, 3 to 12 Amp drives

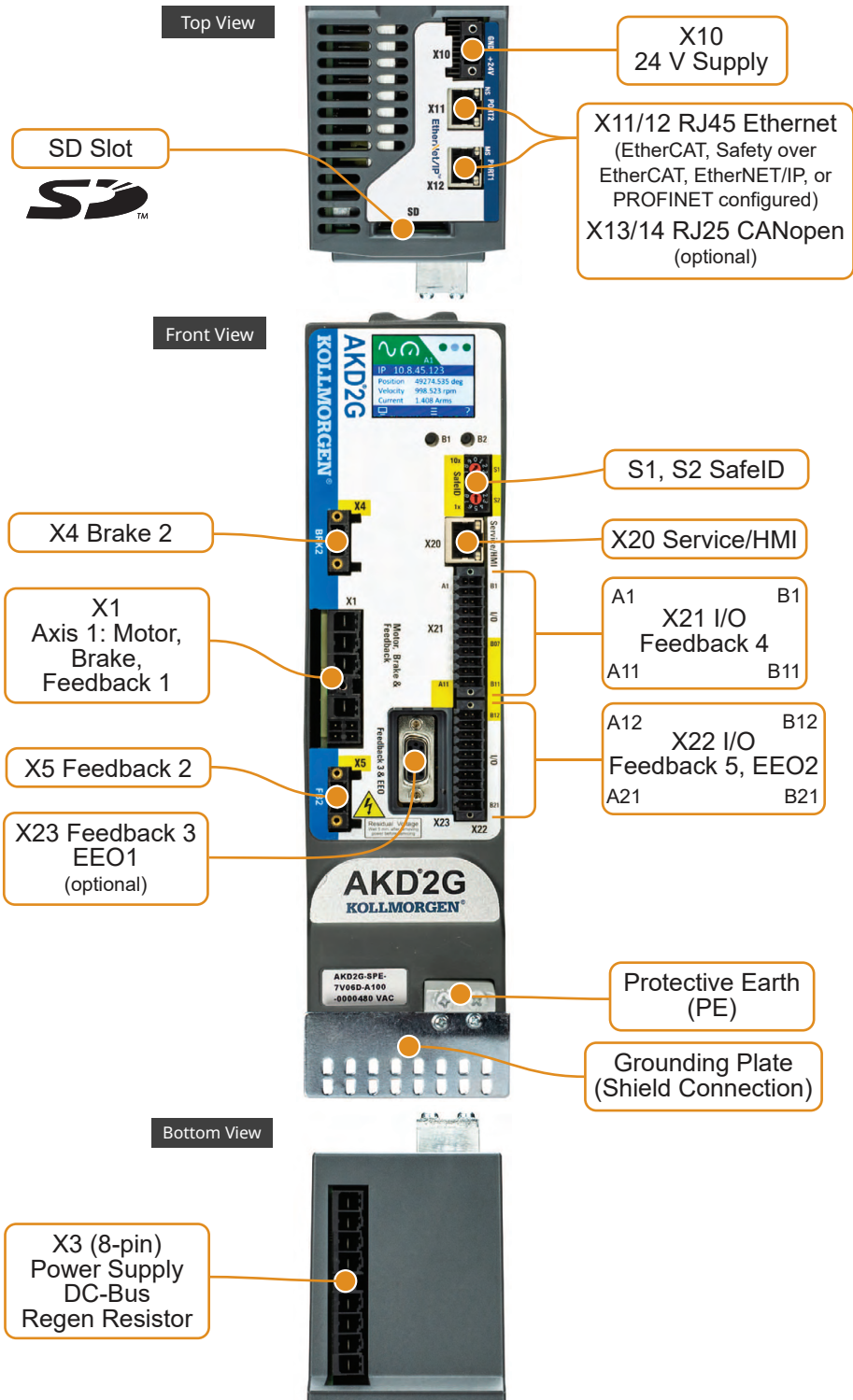

7.5.2.2 AKD2G 480 Vac, 24 Amp drive

NOTE

The graphics shows an AKD2G with supply voltage 480 V.
Optional: I/O, F3 or DX (→ # 37).

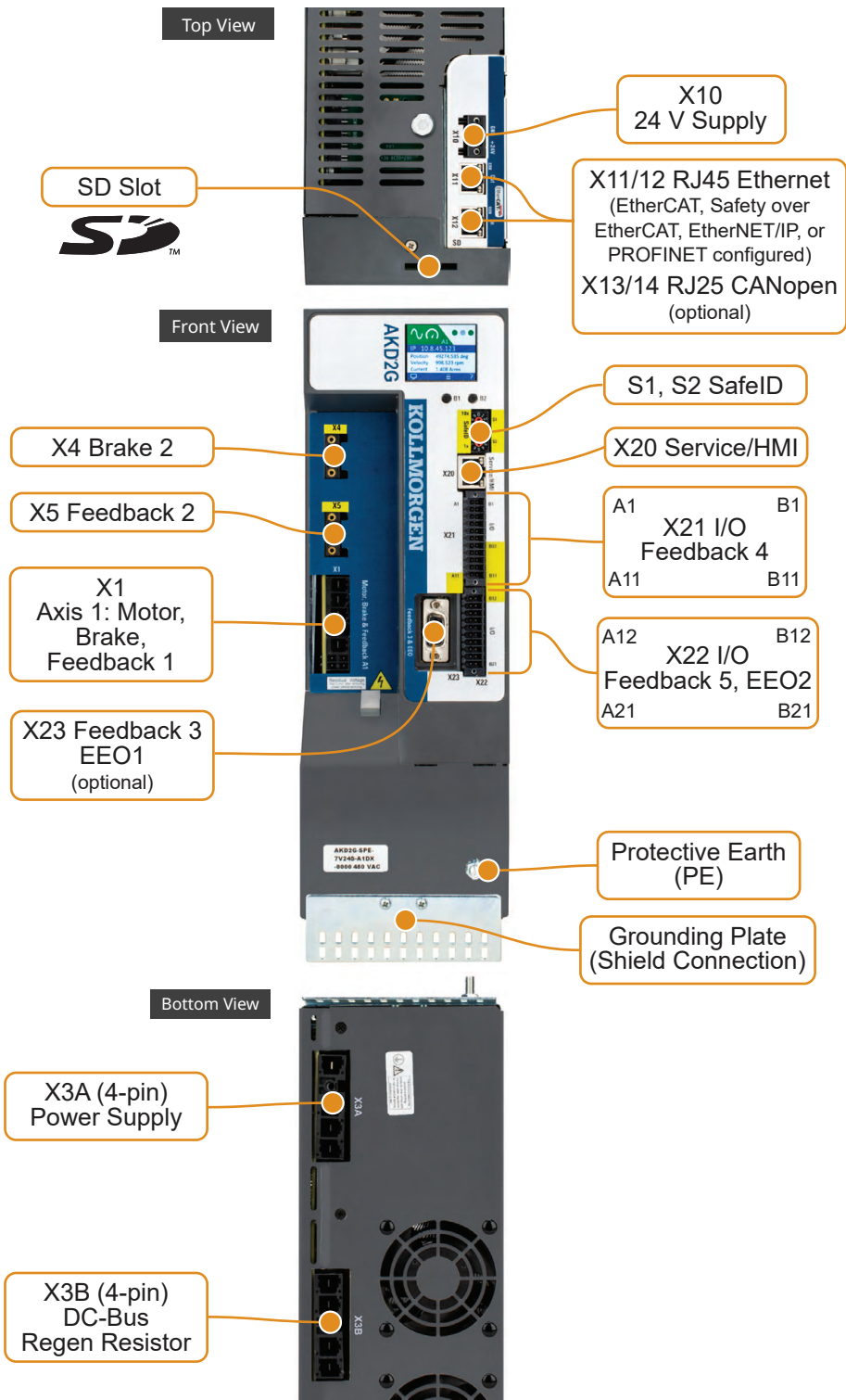

7.5.3 Connector Position AKD2G-Sxx-6VxxD

NOTE

The graphics shows a dual axis drive (supply voltage 110 V to 240 V).
Optional: F3 option for additional X23 (→ # 37).

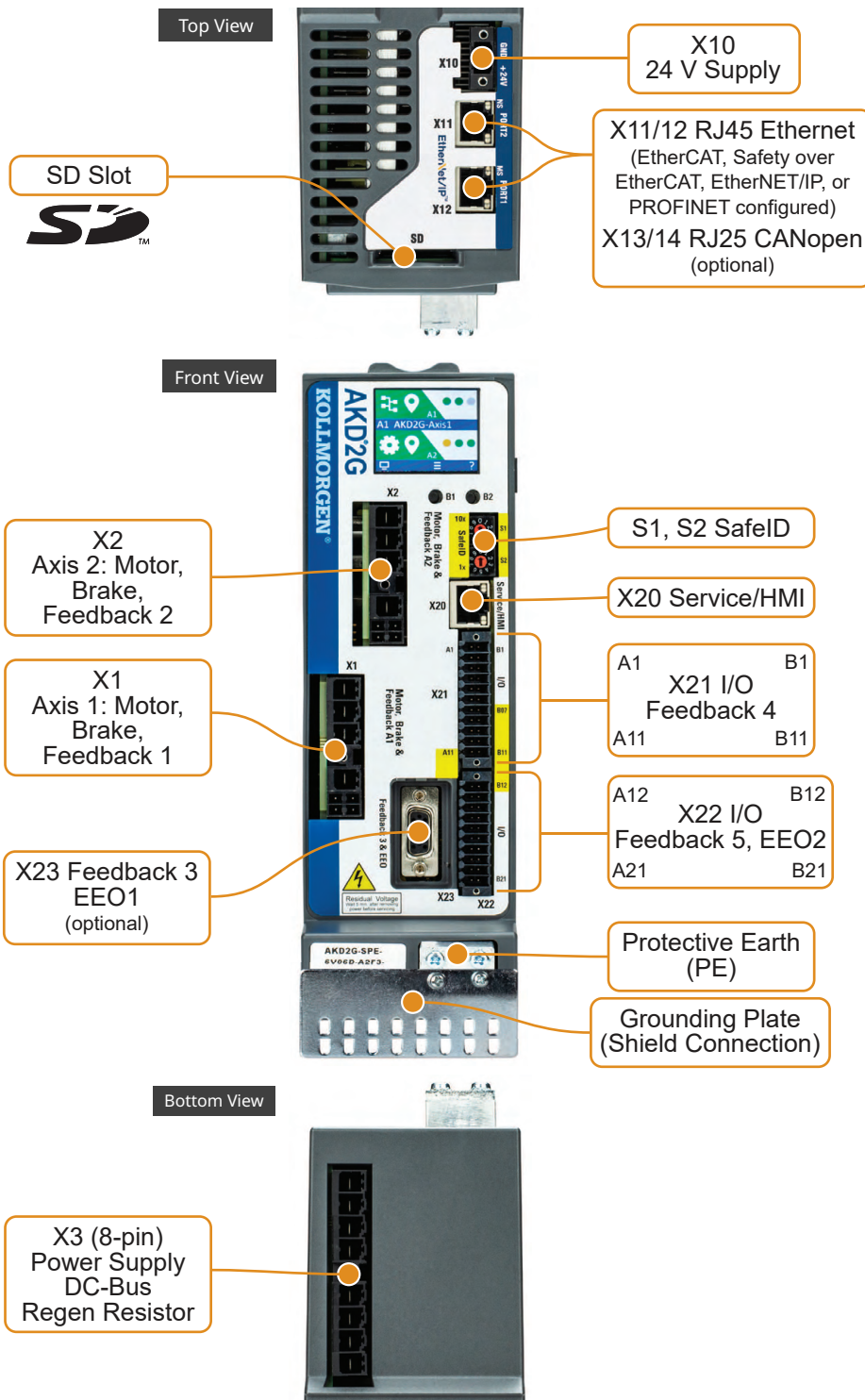

7.5.4 Connector Position AKD2G-Sxx-7VxxD

NOTE

The graphics shows a dual axis drive (supply voltage 240 V to 480 V).
Optional: F3 option for additional X23 (→ # 37).

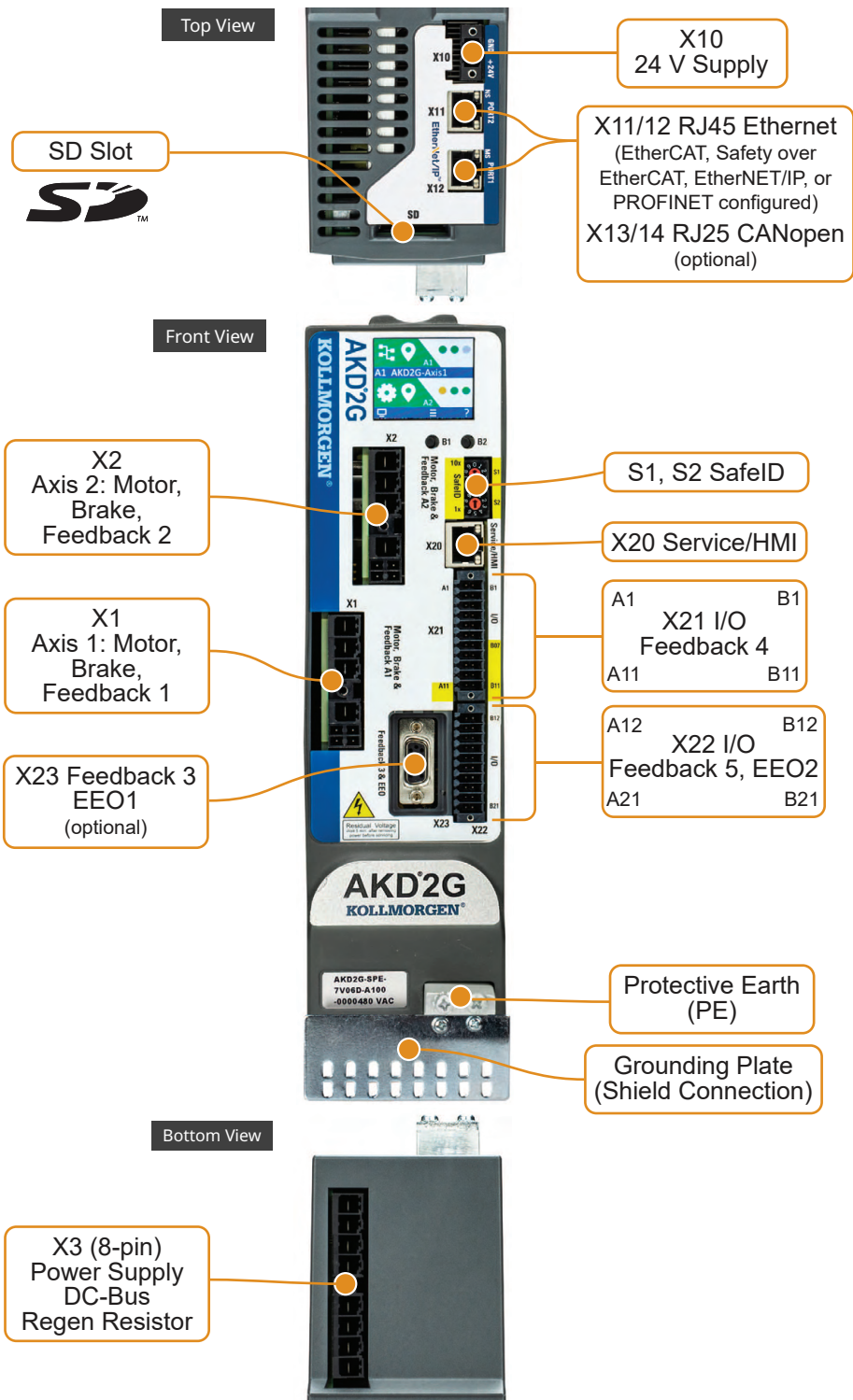

7.5.5 Wiring overview, single axis drive

AKD2G Sxx-xxS 3-12 Amp Drives

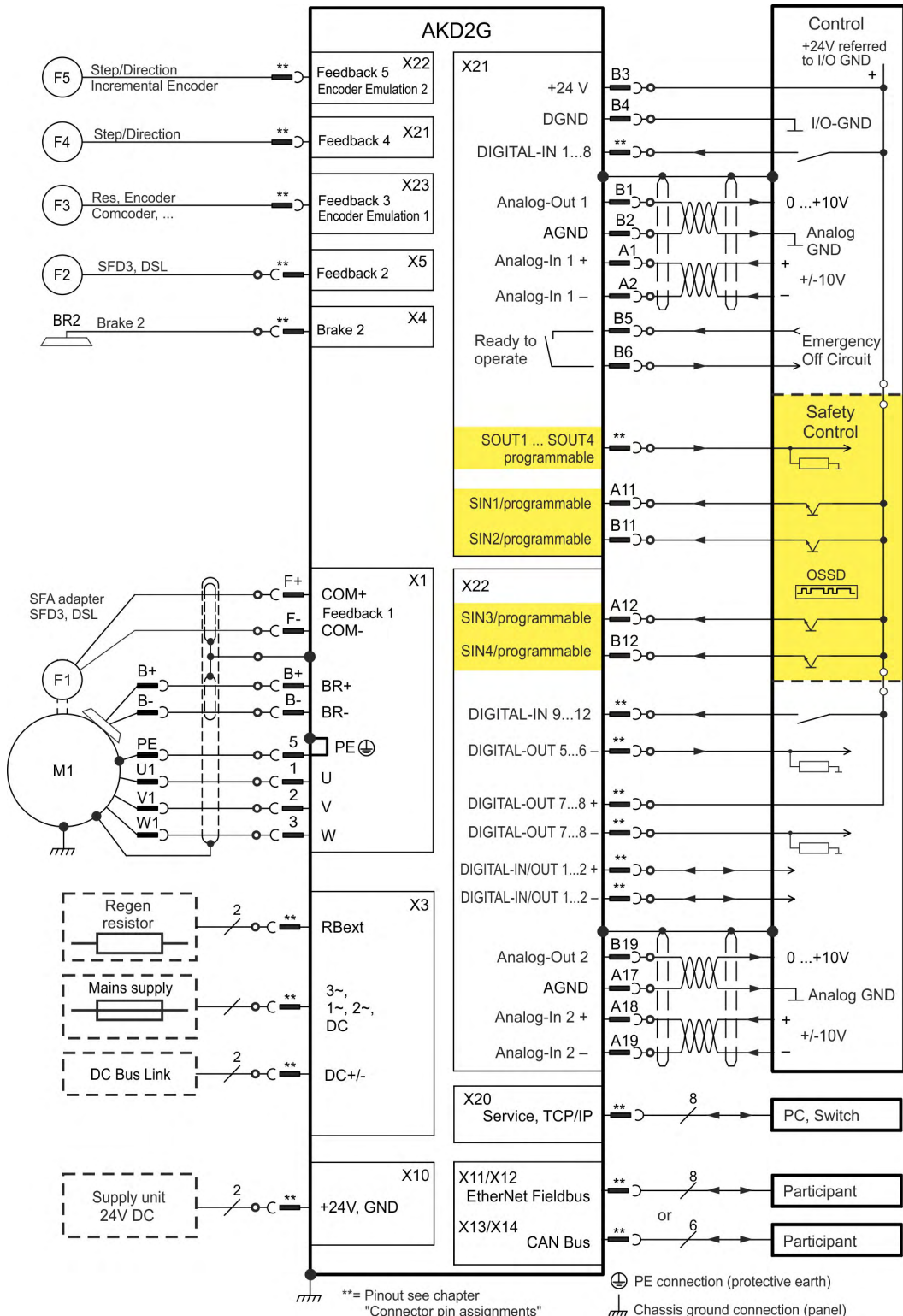

AKD2G Sxx-724S 24 Amp Drives

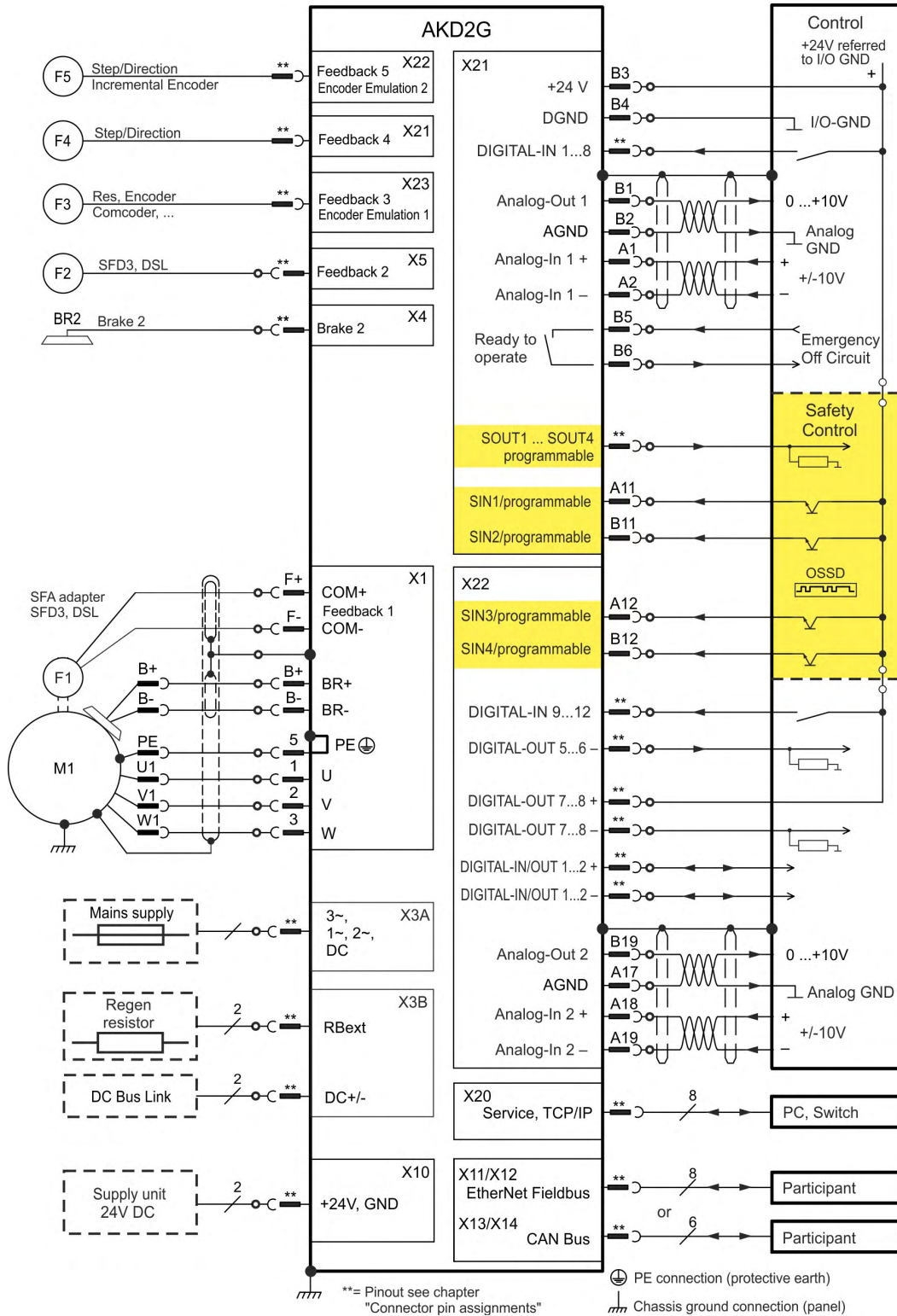

7.5.6 Wiring overview, dual axis drive

AKD2G Sxx-xxD 3-12 Amp Drives

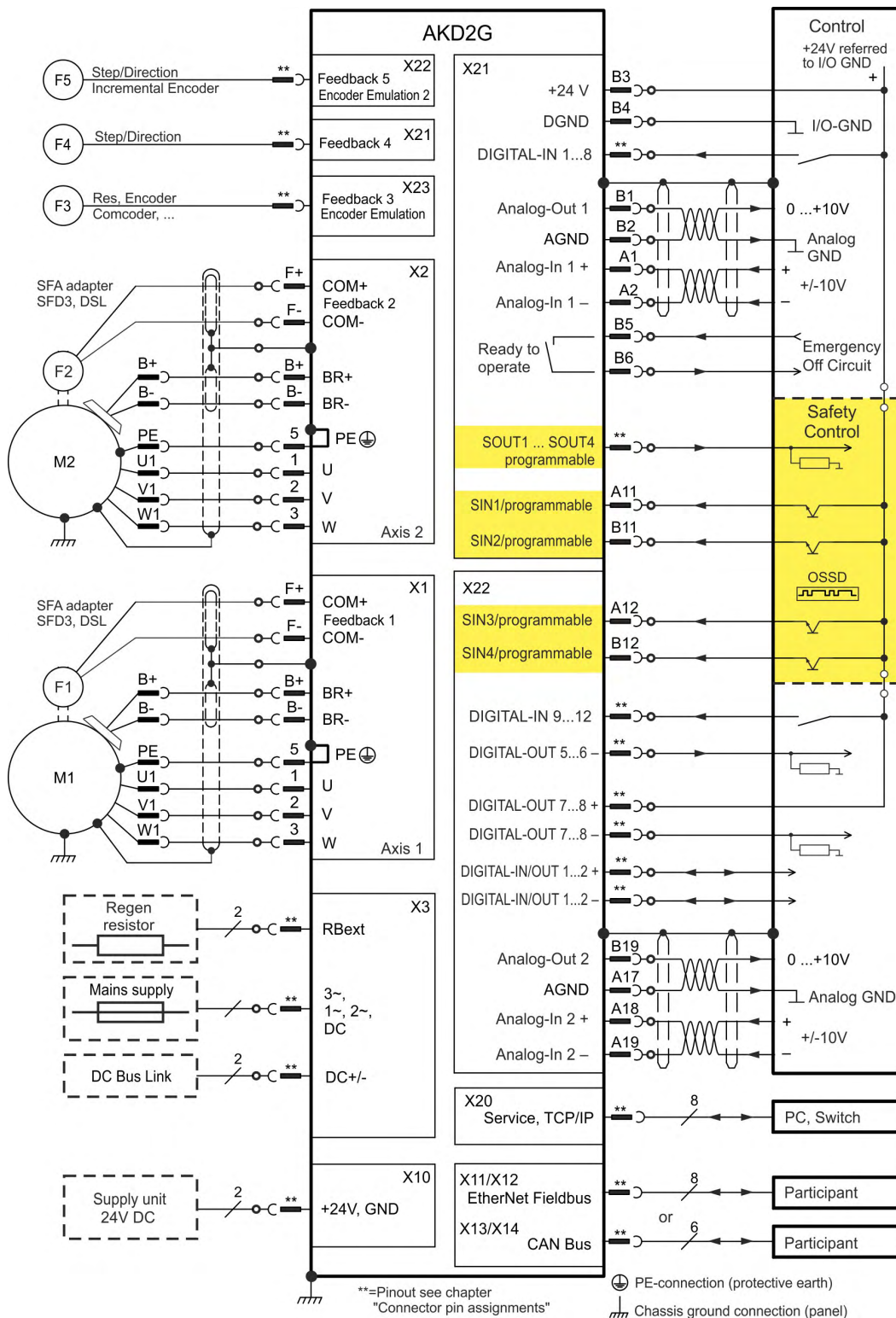

7.5.7 Connector pinout

Information to wiring, mating connectors and cables (→ # 63).

7.5.7.1 X1 and X2: Motor, Brake, Feedback 1

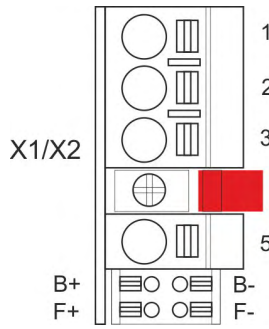

The diagram shows a terminal block with the following connections:

- Pin 1: Motor phase U
- Pin 2: Motor phase V
- Pin 3: Motor phase W
- Pin 5: Protective earth (PE)
- B+: Motor holding brake +
- B-: Motor holding brake -
- F+: SFD3 + or HIPERFACE DSL +
- F-: SFD3 - or HIPERFACE DSL -

Additional notes for pins 1, 2, and 3:

- 4 pin, pitch 7.62 mm plus 2x2 pin pitch 3.81 mm
- Spring clamps
- Locking screw, tightening torque 0.5 Nm (4.4 inlbs)
- Motor power, Motor brake (X1: axis 1, X2: axis 2)
- X1: Input for commutation feedback 1 (→ # 118)
- X2: Input for commutation feedback 2 (→ # 118)

Wiring example:

- DC Bus link (→ # 103)
- Motor single cable connection (→ # 108)
- Motor dual cable connection (→ # 110)

Pin	Label	Signal	Description
1	U	U	Motor phase U
2	V	V	Motor phase V
3	W	W	Motor phase W
retention latch, shield screw			
5	PE	PE	Protective earth
B+	B+	BR+	Motor holding brake +
B-	B-	BR-	Motor holding brake -
F+	F+	COM+	SFD3 + or HIPERFACE DSL +
F-	F-	COM-	SFD3 - or HIPERFACE DSL -

7.5.7.2 X3: Mains, regen resistor, DC-Bus

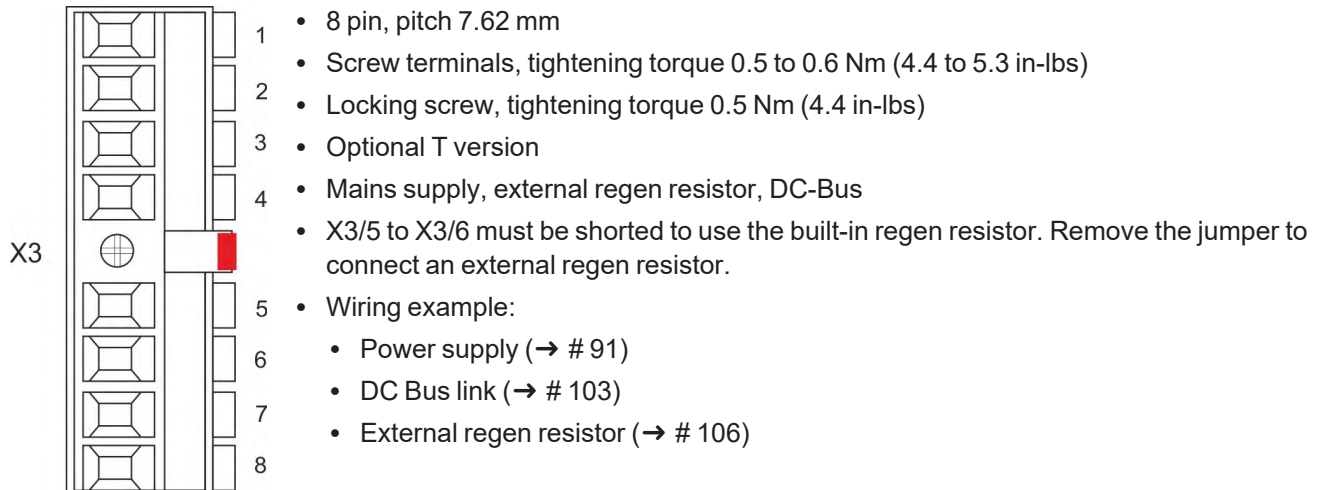

Pin	Label	Signal	Description
1	PE	PE	Protective earth
2	R	L1	3~ mains supply L1, 1~ supply L, DC supply +
3	S	L2	3~ mains supply L2
4	T	L3	3~ mains supply L3, 1~ supply N, DC supply -
5	Ri	RBint	internal regen resistor
6	RE	-RB	external regen resistor -
7	+DC	+DC (+RBext)	DC Bus link+ and/or external regen resistor +
8	-DC	-DC	DC Bus link -

7.5.7.3 X3A/X3B: Mains, regen resistor, DC-Bus

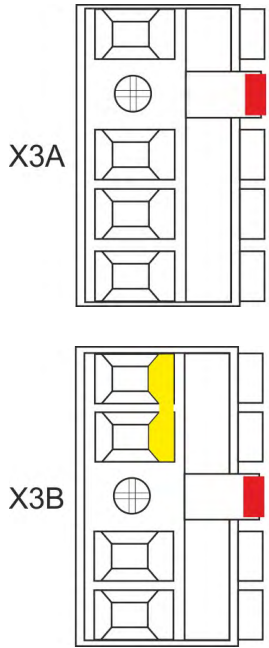

- 2x 4 pin, pitch 10.16 mm
- Screw terminals, tightening torque 2 Nm (18 in-lbs)
- Mains supply, external regen resistor, DC-Bus
- X3A/5 to X3B/6 must be shorted to use the built-in regen resistor. Remove the jumper to connect an external regen resistor.
- Wiring example:
 - Power supply (→ # 91)
 - DC Bus link (→ # 103)
 - External regen resistor (→ # 106)

X3A

Pin	Label	Signal	Description
1	PE	PE	Protective earth
2	R	L1	3~ mains supply L1, 1~ supply L, DC supply +
3	S	L2	3~ mains supply L2
4	T	L3	3~ mains supply L3, 1~ supply N, DC supply -

X3B

Pin	Label	Signal	Description
5	Ri	RBint	internal regen resistor
6	RE	-RB	external regen resistor -
7	+DC	+DC (+RBext)	DC Bus link+ and/or external regen resistor +
8	-DC	-DC	DC Bus link -

7.5.7.4 X4: Second Brake

NOTE

Use with single axis drives and Safety Option 3 for safety functions, which require a second brake.

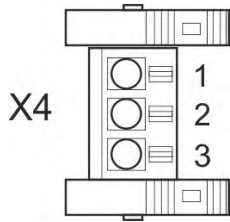

- 3 pin, pitch 3.81 mm
- Spring clamps
- Second motor brake
- Required for SIL3 brake control

Pin	Signal	Description
1	PE	Protective earth
2	BR2-	Second (external) brake -
3	BR2+	Second (external) brake +

7.5.7.5 X5: Feedback 2

NOTE

Use with single axis drives and Safety Option 3 for application, which require a second feedback.

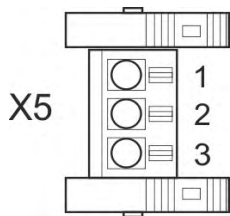

- 3 pin, pitch 3.81 mm
- Spring clamps
- Input for feedback 2 (→ # 119)

Pin	Signal	Description
1	PE	Protective earth
2	COM2-	Second SFD3 - or Second/Safe HIPERFACE DSL -
3	COM2+	Second SFD3 + or Second/Safe HIPERFACE DSL +

7.5.7.6 X10: 24 VDC

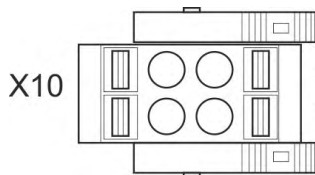

- 2 pin, pitch 5.08 mm
- Spring clamps
- T version
- 24 VDC supply voltage
- Wiring example: (→ # 102)

Pin	Signal	Description
1	+ 24 V	+24 VDC supply voltage, PELV
2	GND	Ground for 24 VDC supply voltage, PELV

7.5.7.7 X11, X12: EtherNet Fieldbus

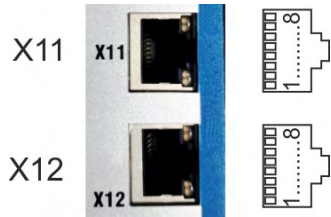

- RJ45 with built-in green/red dual-color LED
- EtherCAT, EtherNet/IP, PROFINET
- Interface Details: (→ # 155)

Pin	Signal	Description	Pin	Signal	Description
1	Tx+	Transmit +	5	Term.	Termination
2	Tx-	Transmit -	6	Rx-	Receive -
3	Rx+	Receive +	7	Term.	Termination
4	Term.	Termination	8	Term.	Termination

7.5.7.8 X13, X14: CAN bus (optional)



- RJ25
- X14 IN port, X13 OUT port
- Up to 1 Mbit operation
- Node ID to be set by WorkBench
- Interface Details: (→ # 158)

Pin	Signal	Description	Pin	Signal	Description
1	n.c.	not used	4	CAN_low	CAN bus low signal
2	Shield	Chassis	5	CAN_GND	CAN bus ground
3	CAN_high	CAN bus high signal	6	n.c.	not used

7.5.7.9 X20: Service



- RJ45 with built-in green and yellow LEDs
- 100/10 Mbit EtherNet TCP/IP, Modbus/TCP
- Supports auto-IP, DHCP and fixed IP addressing
- Supports point-to-point (i.e. Auto-IP) and connection by using network switches
- Supports automatic discovery in WorkBench if in the same sub-net.
- Interface Details: (→ # 160)

Pin	Signal	Description	Pin	Signal	Description
1	Tx+	Transmit +	5	Term.	Termination
2	Tx-	Transmit -	6	Rx-	Receive -
3	Rx+	Receive +	7	Term.	Termination
4	Term.	Termination	8	Term.	Termination

7.5.7.10 X21: I/O, Feedback 4

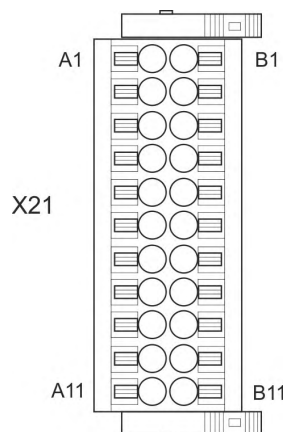

- 2 x 11 pins (left column A, right column B), pitch 3.5 mm
- Spring clamps
- Analog and digital I/O
- Input for feedback 4 (→ # 120)
- Wiring examples:
 - Analog input (→ # 164)
 - Analog output (→ # 166)
 - Digital input (→ # 166)
 - Digital Output (→ # 171)
 - Feedback (→ # 120)

Digital I/O connectivity

Pin	Signal	Description
A1	Analog-In (AIN) 1 +	Analog Input +/- 10 V
A2	Analog-In (AIN) 1 -	
A3*	Digital-In (DIN) 1	Fast, isolated, sink, type EN 61131-2 type 1
A4*	Digital-In (DIN) 2	Fast, isolated, sink, type EN 61131-2 type 1
A5	Digital-In (DIN) 3	Slow, isolated, sink, type EN 61131-2 type 1
A6	Digital-In (DIN) 4	Slow, isolated, sink, type EN 61131-2 type 1
A7	Digital-In (DIN) 5	Slow, isolated, sink, type EN 61131-2 type 1
A8	Digital-In (DIN) 6	Slow, isolated, sink, type EN 61131-2 type 1
A9	Digital-In (DIN) 7	Slow, isolated, sink, type EN 61131-2 type 1
A10	Digital-In (DIN) 8	Slow, isolated, sink, type EN 61131-2 type 1
A11	SIN1	Slow, isolated, sink, fail-safe, functional safety input 1
B1	Analog-Out (AOUT) 1	Analog Output, 0 to +10 V
B2	AGND	Ground for analog I/O
B3	+24 V	+24 VDC for digital I/O and STO
B4	DGND	Ground for digital I/O and STO
B5	Digital-Out (DOOUT) 9 +	Relay contact, normally open, 24 VDC, 1A
B6	Digital-Out (DOOUT) 9 -	Relay contact, normally open, 24 VDC, 1A
B7	SOUT1	Isolated, high-side, safety: 172 mA, safe output
B8	SOUT2	Isolated, high-side, safety: 172 mA, safe output
B9	SOUT3	Isolated, high-side, safety: 172 mA, safe output
B10	SOUT4	Isolated, high-side, safety: 172 mA, safe output
B11	SIN2	Slow, isolated, sink, fail-safe, functional safety input 2

*Feedback 4 connectivity, Step/Direction CW/CCW (input)

Pin	Signal	Description
A3	Step, CW	Fast, isolated, sink, type EN 61131-2 type 1
A4	Direction, CCW	Fast, isolated, sink, type EN 61131-2 type 1

7.5.7.11 X22: I/O, EEO2, Feedback 5

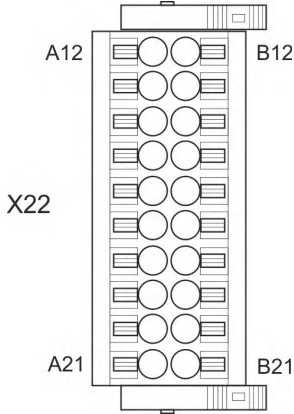

- 2 x 10 pins (left column A, right column B), pitch 3.5 mm
- Spring clamps
- Analog and digital I/O
- Input for feedback 5 (→ # 121)
- Output for incremental encoder emulation (EEO2)
- Wiring examples:
 - Analog input (→ # 164)
 - Analog output (→ # 166)
 - Digital input (→ # 166)
 - Digital output (→ # 171)
 - Feedback (→ # 121)
 - Encoder emulation (EEO2) (→ # 151)
 - Master-Slave (→ # 153)

Digital I/O connectivity

Pin	Signal	Description
A12	SIN3	Slow, isolated, sink, fail-safe, functional safety input 3
A13	Digital-In (DIN) 9	Slow, isolated, sink, type EN 61131-2 type 1
A14	Digital-In (DIN) 10	Slow, isolated, sink, type EN 61131-2 type 1
A15	Digital-In (DIN) 11	Slow, isolated, sink, type EN 61131-2 type 1
A16	Digital-In (DIN) 12	Slow, isolated, sink, type EN 61131-2 type 1
A17	AGND	Ground for analog I/O
A18	Analog-In (AIN) 2+	Analog Input, +/- 10 V
A19	Analog-In (AIN) 2-	
A20*	Digital-In/Out (DIO) 1 +	RS485 input or output
A21*	Digital-In/Out (DIO) 1 -	RS485 input or output
B12	SIN4	Slow, isolated, sink, fail-safe, functional safety input 4
B13	Digital-Out (DOOUT) 5	Isolated, high-side, 100 mA
B14	Digital-Out (DOOUT) 6	Isolated, high-side, 100 mA
B15	Digital-Out (DOOUT) 7 +	Fast, isolated, sink or source, 100 mA
B16	Digital-Out (DOOUT) 7 -	
B17	Digital-Out (DOOUT) 8 +	Fast, isolated, sink or source, 100 mA
B18	Digital-Out (DOOUT) 8 -	
B19	Analog-Out (AOUT) 2	Analog Output, 0 to +10 V
B20*	Digital-In/Out (DIO) 2 +	RS485 input or output
B21*	Digital-In/Out (DIO) 2 -	RS485 input or output

*Feedback 5 (input)						*EEO2 (output)	
Pin	Increm. Encoder	Step/Dir	CW/CCW	BiSS C EnDAT 2.2	SSI	Pin	Increm. Encoder
A20	Track A +	Step +	CW +	CLK+	CLK+	A20	A+
A21	Track A -	Step -	CW -	CLK-	CLK-	A21	A -
B20	Track B +	Dir +	CCW +	DAT+	DAT+	B20	B+
B21	Track B -	Dir -	CCW -	DAT-	DAT-	B21	B -

7.5.7.12 X23: I/O, EEO1, Feedback 3

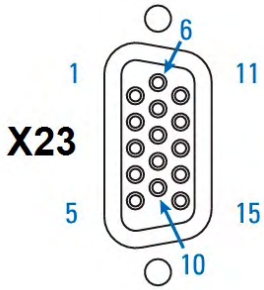

- Sub-D high density 15 pin, female
- Locking screws, tightening torque 0.4 Nm (3.5 inlbs)
- Input for feedback 3 (→ # 122)
- Output for incremental encoder emulation (EEO1)
- Additional Digital-In/Out
- Wiring examples:
 - Feedback (→ # 122)
 - Encoder emulation (EEO1) (→ # 152)
 - Master-Slave (→ # 153)
 - Digital input (→ # 166)
 - Digital output (→ # 171)

Feedback 3 connectivity (input)

Pin	SFD	Resolver	BiSS B	BiSS C	EnDat [®] 2.1	EnDat [®] 2.2*	HIPERFACE [®]	Sine/ Cos	Sine/ Cos +Hall	Incr. Enc.	Incr. Enc. +Hall	Hall	SSI	Step/ Dir	CW/ CCW
1	-	-	-	-	-	-	-	-	Hall U	-	Hall U	Hall U	-	-	-
2	-	-	CLK+	CLK+	CLK+	CLK+	-	-	Hall V	-	Hall V	Hall V	-	-	-
3	-	-	CLK-	CLK-	CLK-	CLK-	-	-	Hall W	-	Hall W	Hall W	-	-	-
4	SEN+	-	SEN+	SEN+	SEN+	SEN+	I	SEN+	SEN+	SEN+	SEN+	-	-	-	-
5	SEN-	-	SEN-	SEN-	SEN-	SEN-		SEN-	SEN-	SEN-	SEN-	SEN-	-	-	-
6	COM+	R1 Ref+	DAT+	DAT+	DAT+	DAT+	DAT+	Zero+	Zero+	Zero+	Zero+	-	D+	-	-
7	COM-	R2 Ref-	DAT-	DAT-	DAT-	DAT-	DAT-	Zero-	Zero-	Zero-	Zero-	-	D-	-	-
8	Th+	Th+	Th+	Th+	Th+	Th+	Th+	Th+	Th+	Th+	Th+	-	Th+	Th+	Th+
9	Th-	Th-	Th-	Th-	Th-	Th-	Th-	Th-	Th-	Th-	Th-	-	Th-	Th-	Th-
10	+5 V	-	+5 V	+5 V	+5 V	+5 V	8-9 V	+5 V	+5 V	+5 V	+5 V	+5 V	+5 V	+5 V	+5 V
11	0 V	-	0 V	0 V	0 V	0 V	0 V	0 V	0 V	0 V	0 V	0 V	0 V	0 V	0 V
12	-	S1 SIN+	A+	-	A+	-	SIN+	A+	A+	A+	A+	-	-	Step+	CW+
13	-	S3 SIN-	A-	-	A-	-	SIN-	A-	A-	A-	A-	-	-	Step-	CW-
14	-	S2 COS+	B+	-	B+	-	COS+	B+	B+	B+	B+	-	-	CCW+	CCW+
15	-	S4 COS-	B-	-	B-	-	COS-	B-	B-	B-	B-	-	-	CCW-	CCW-

CL = CLOCK, D = DATA, S = SENSE, Th = Thermal control, Z = Zero

 = DC Terminated, can be overridden with DIO#.TERMDIO#.TERM

 = Optional

 = Information digitally communicated on COM+/- channel.

EEO1 connectivity (output)

Pin	Incremental Encoder
6	Zero+
7	Zero-
11	0 V
12	A +
13	A-
14	B+
15	B-

Digital I/O connectivity

Pin	Digital I/O
2	Digital-In/Out 6 +
3	Digital-In/Out 6 -
6	Digital-In/Out 5 +
7	Digital-In/Out 5 -
10	+5 V
11	0 V
12	Digital-In/Out 3 +
13	Digital-In/Out 3 -
14	Digital-In/Out 4 +
15	Digital-In/Out 4 -

7.5.7.13 X41: SFA Feedback converter, EEO3/EEO4 EXX3/EXX4 (accessory)

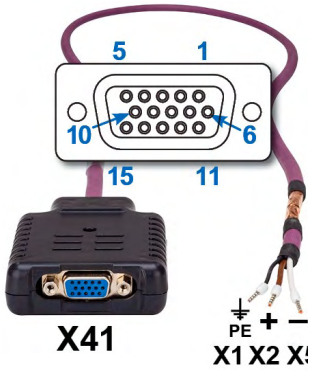

- Sub-D high density 15 pin, female
- Locking screws, tightening torque 0.4 Nm (3.5 in•lbs)
- 1 m cable, 3 flying leads with ferrules for connection to X1, X2, X5 (only on 24 A model)
- Input for electronic gearing
- When connected to X1: Input for feedback 1 (→ # 116)
- When connected to X2: Input for feedback 2 (→ # 116)
- When connected to X5 (only on 24 A model): Input for feedback 2 (→ # 116)
- Output for incremental encoder emulation (EEO3 / EEO4)(EXX3 / EXX4) (→ # 151) - Only available on "-EXX" (Encoder) models
- SFA adapter converts conventional feedback signals to 2 wire feedback format
- Wiring examples:
 - Feedback and Encoder emulation (→ # 137)
 - Master-Slave (→ # 153)

Feedback 1/2 connectivity (input)

Pin	SFD	Resolver	BiSS B	BiSS C	EnDat [®] 2.1	EnDat [®] 2.2*	HIPERFACE [®]	Sine/ Cos	Sine/ Cos +Hall	Incr. Enc.	Incr. Enc. +Hall	Hall	SSI
1	-	-	-	-	-	-	-	-	Hall U	-	Hall U	Hall U	-
2	-	-	CLK+	CLK+	CLK+	CLK+	-	-	Hall V	-	Hall V	Hall V	-
3	-	-	CLK-	CLK-	CLK-	CLK-	-	-	Hall W	-	Hall W	Hall W	-
4	SEN+	-	SEN+	SEN+	SEN+	SEN+	I	SEN+	SEN+	SEN+	SEN+	-	-
5	SEN-	-	SEN-	SEN-	SEN-	SEN-		SEN-	SEN-	SEN-	SEN-	SEN-	-
6	COM+	R1 Ref+	DAT+	DAT+	DAT+	DAT+	DAT+	Zero+	Zero+	Zero+	Zero+	-	D+
7	COM-	R2 Ref-	DAT-	DAT-	DAT-	DAT-	DAT-	Zero-	Zero-	Zero-	Zero-	-	D-
8	Th+	Th+	Th+	Th+	Th+	Th+	Th+	Th+	Th+	Th+	Th+	-	Th+
9	Th-	Th-	Th-	Th-	Th-	Th-	Th-	Th-	Th-	Th-	Th-	-	Th-
10	+5 V	-	+5 V	+5 V	+5 V	+5 V	8-9 V	+5 V	+5 V	+5 V	+5 V	+5 V	+5 V
11	0 V	-	0 V	0 V	0 V	0 V	0 V	0 V	0 V	0 V	0 V	0 V	0 V
12	-	S1 SIN+	A+	-	A+	-	SIN+	A+	A+	A+	A+	-	-
13	-	S3 SIN-	A-	-	A-	-	SIN-	A-	A-	A-	A-	-	-
14	-	S2 COS+	B+	-	B+	-	COS+	B+	B+	B+	B+	-	-
15	-	S4 COS-	B-	-	B-	-	COS-	B-	B-	B-	B-	-	-

CL = CLOCK, D = DATA, S = SENSE, Th = Thermal control, Z = Zero

(1) : Resolver with AKD2G-CON-SFA-R00 only, all other feedback devices with AKD2G-CON-SFA-E00 only

■ = DC Terminated, can be overridden with [DIO#.TERM](#)

■ = Optional

■ = Information digitally communicated on COM+/- channel.

EEO3 / EEO4 Connectivity (output)

X41 Pin	Incremental Encoder
6	Zero+
7	Zero-
11	0 V
12	A +
13	A-
14	B+
15	B-

7.6 Power and Logic Voltage Supply (X3/X10)

7.6.1 Electrical Supply Connection

7.6.1.1 Connection to various mains supply networks AKD2G-Sxx-6V (100V to 240V)

NOTICE

An isolating transformer is required for 400 to 480V networks to get a maximum voltage of 240V +10%.

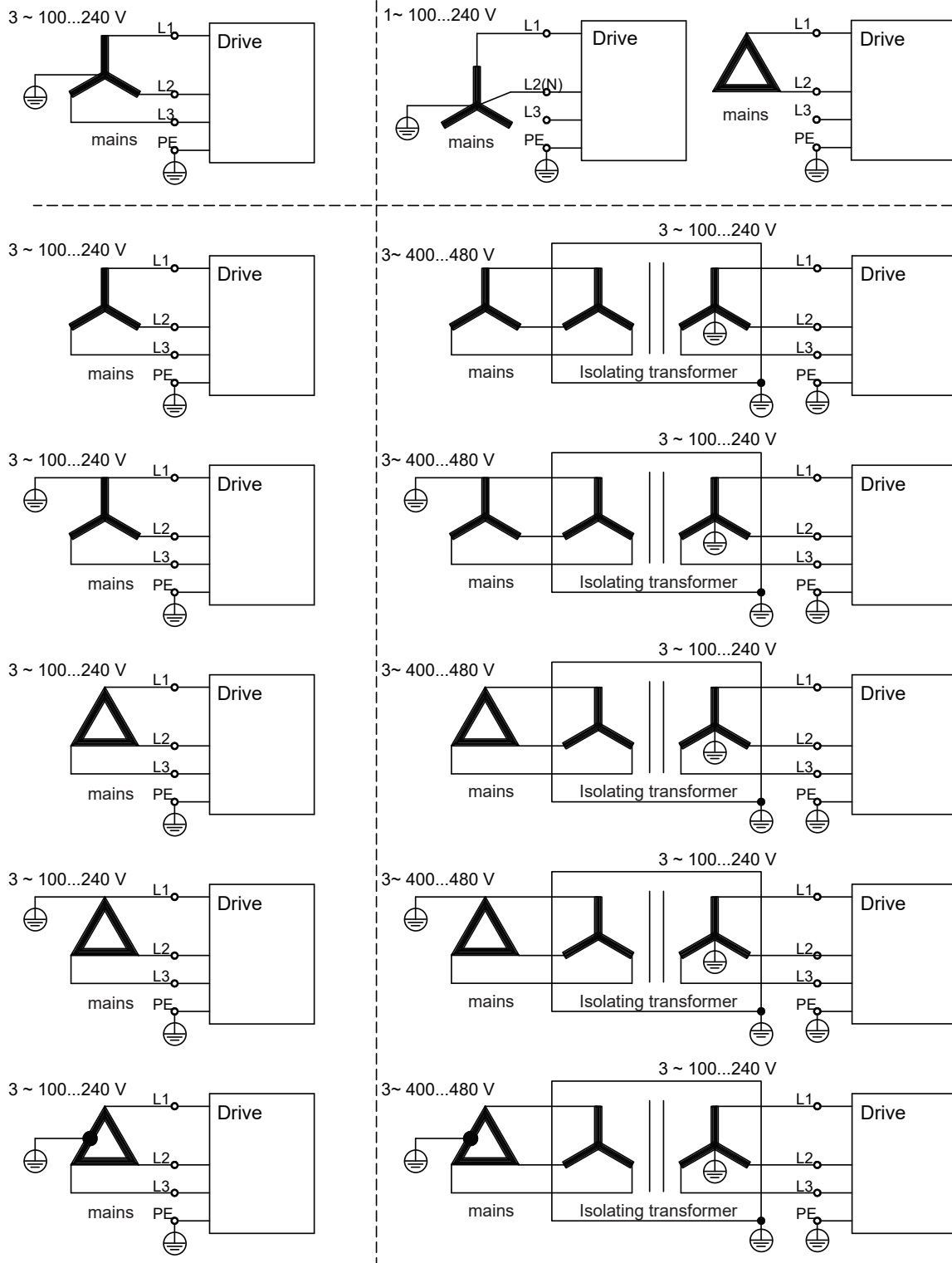

7.6.1.2 Connection to various mains supply networks AKD2G-Sxx-7V (240V to 480V)

NOTICE

An isolating transformer is required for 120V networks to get a minimum voltage of 240V +10%.

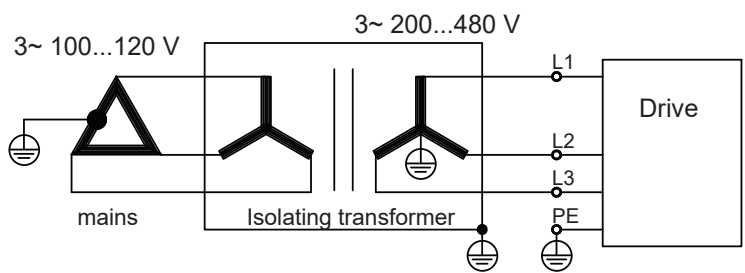
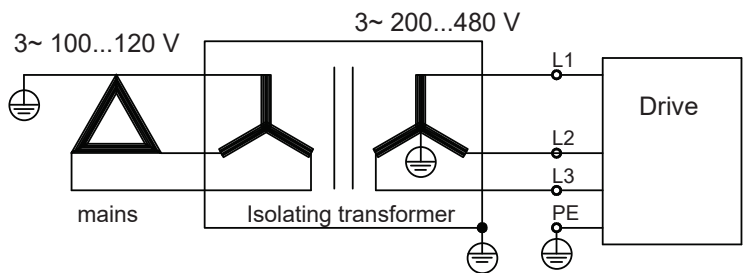
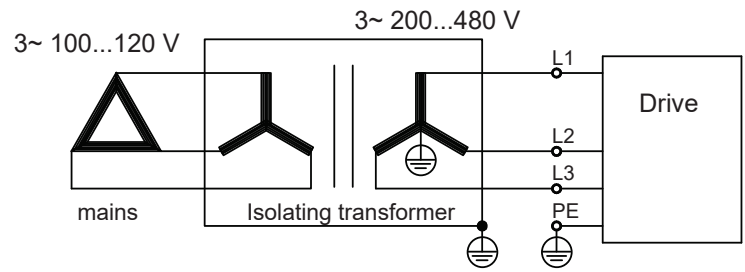
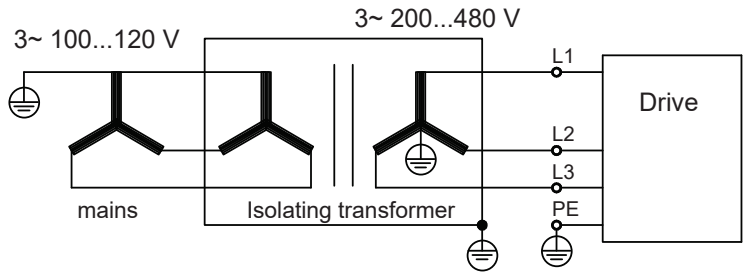
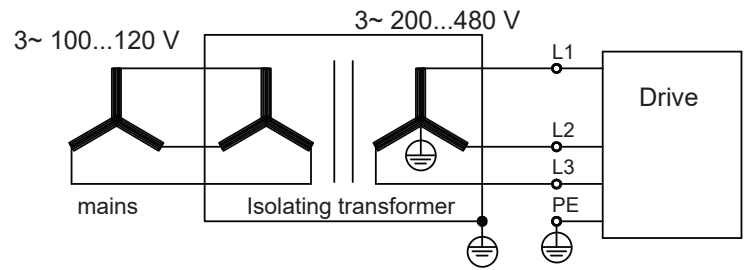
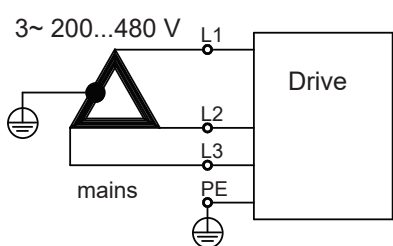
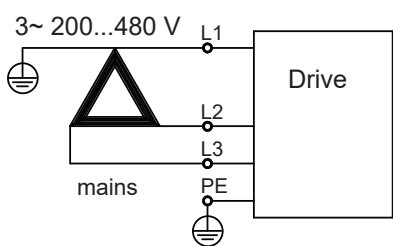
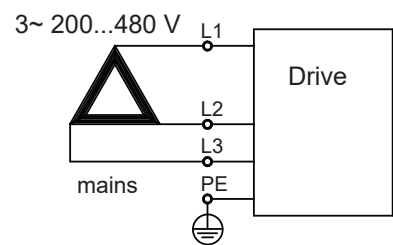
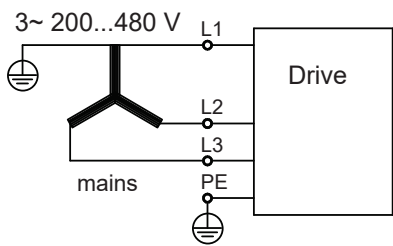
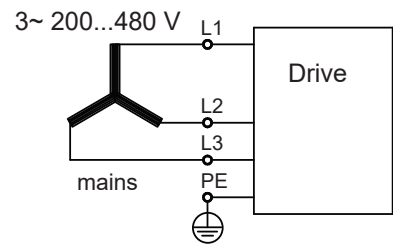
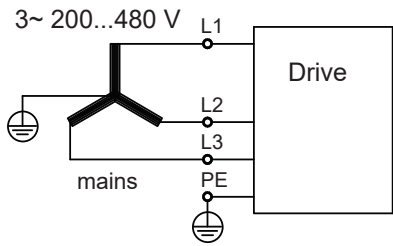

7.6.2 Mains power supply connector X3/X3A

Drives in the AKD2G series can be supplied as follows:

AKD2G-Sxx-6V

- 1, 2 or 3 phase industrial AC supply networks (TN-S or TT, see [KDN](#)): (→ # 44)
- DC supply networks: (→ # 44)

AKD2G-Sxx-7V

- 3 phase industrial AC supply networks (TN-S or TT, see [KDN](#)): (→ # 47)
- DC supply networks: (→ # 47)

For connection to corner grounded delta supply networks contact Kollmorgen customer support.

Periodic overvoltages between phases (L1, L2, L3) and the PE/housing of the drive must not exceed 1,000V peak. In accordance with IEC 61800, voltage spikes (< 50 µs) between phases must not exceed 1,000V. Voltage spikes (< 50 µs) between a phase and the PE/housing must not exceed 2,000V.

- 8/4 pin, pitch 7.62/10.16 mm
- optional T version
- Wiring example:
 - 1 phase AC supply (→ # 92)
 - 2 phase AC supply (→ # 92)
 - 3 phase AC supply (→ # 93)
 - DC supply (→ # 95)
- AKD2G-Sxx-6V requires external EMC filter for use in industrial environment, product category C.
- Mating connector data (→ # 63)
- Fusing with different system structures (→ # 97) ff

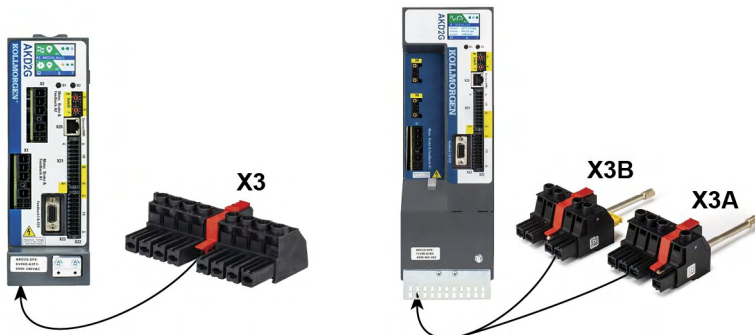

Pin	Label	Signal	1~ Supply	2~Supply	3~ Supply	DC Supply
1	PE	PE	Protective earth	Protective earth	Protective earth	Protective earth
2	R	L1	Phase L1	Phase L1	Phase L1	+ DC
3	S	L2	n.c.	n.c.	Phase L2	n.c.
4	T	L3	Neutral N	Phase L2	Phase L3	- DC

For DC supply: observe notes (→ # 95).

7.6.2.1 Wiring examples mains power supply

One phase AC mains (AKD2G-Sxx-6V)

- Directly to one phase supply network with neutral line.
- Activate single phase supply (VBUS.THREEPHASE = 0).
- Set VBUS.ACNO MINAL to desired nominal AC line voltage for lines other than nominal rated VAC.
- For complete information refer to WorkBench online help, AKD2G-S User Manual, section Power Setting.
- AC line filtering to be provided by the user. Use filter type FN2090, refer to the *Accessories Manual* for more information. Use shielded cable between filter and drive.

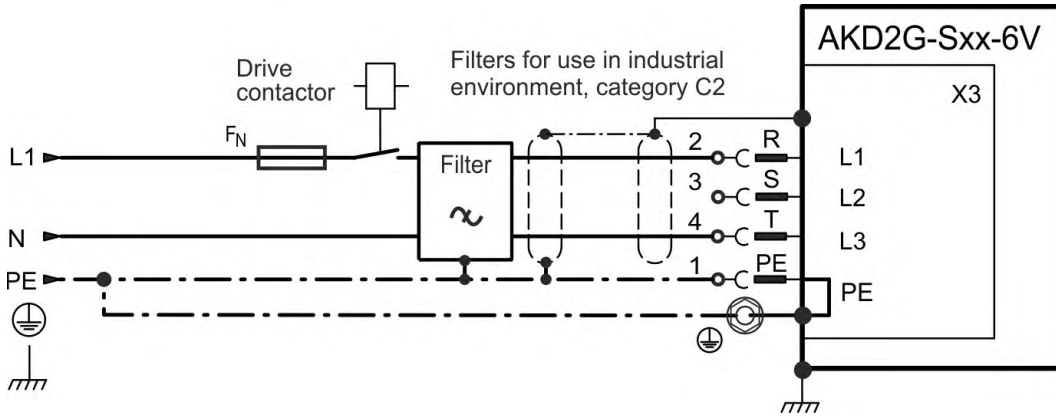

Two phases AC mains (AKD2G-Sxx-6V)

- Directly to two-phase supply network without neutral line.
- Activate single phase supply (VBUS.THREEPHASE = 0).
- Set VBUS.ACNO MINAL to desired nominal AC line voltage for lines other than nominal rated VAC.
- For complete information refer to WorkBench online help, AKD2G-S User Manual, section Power Setting.
- AC line filtering to be provided by the user. Use filter type FN2090, refer to the *Accessories Manual* for more information. Use shielded cable between filter and drive.

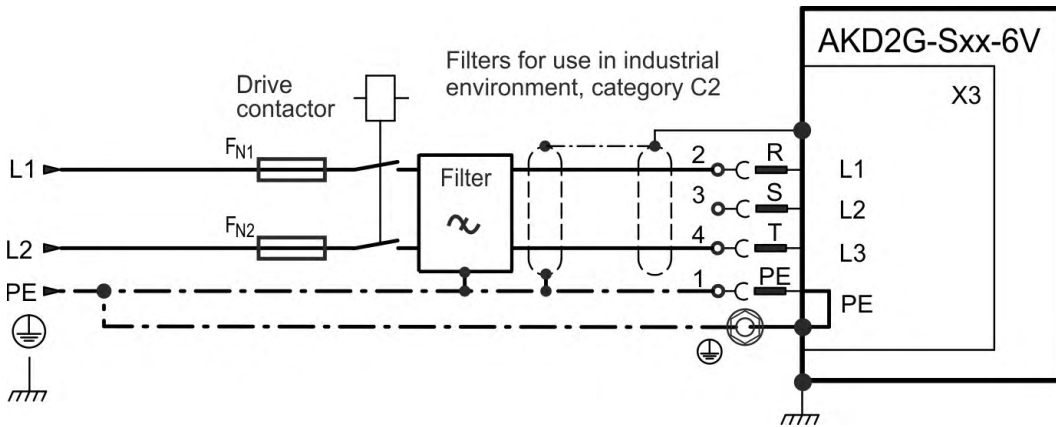

Three phases AC mains (all AKD2G-Sxx-)

- Directly to 3-phase supply network.
- Activate 3-phase supply (VBUS.THREEPHASE = 1).
- Set VBUS.AC NOMINAL to desired nominal AC line voltage for lines other than nominal rated VAC.
- For complete information refer to WorkBench online help, AKD2G-S User Manual, section Power Setting.
- AC line filtering to be provided by the user. Refer to the *Accessories Manual* for more filter description. Use shielded cable between filter and drive.
 - AKD2G-Sxx-6V:
 - Motor cable < 10 m: use filter FN 3288 in industrial environment, category C2.
 - Motor cable ≥ 10 m: use filter FN 3288 in industrial environment, category C3.
 - AKD2G-Sxx-7V up to 12 Amps:
 - Motor cable < 10 m: no filter, in industrial environment, category C3.
 - Motor cable < 10 m: use filter FN 3288 in industrial environment, category C2.
 - Motor cable ≥ 10 m: use filter FN 3288 in industrial environment, category C3.
 - AKD2G-Sxx-7V 24:
 - Motor cable < 10 m: no filter, in industrial environment, category C2.
 - Motor cable ≥ 10 m: no filter, in industrial environment, category C3.
 - Motor cable ≥ 10 m: use filter FN 3288 in industrial environment, category C2.

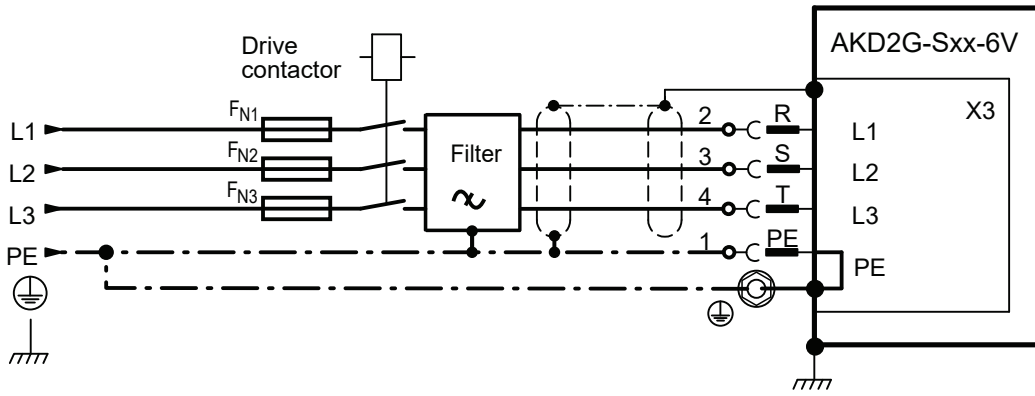

Motor Cable Length	EMI Category
< 10 m	C2
≥ 10 m	C3

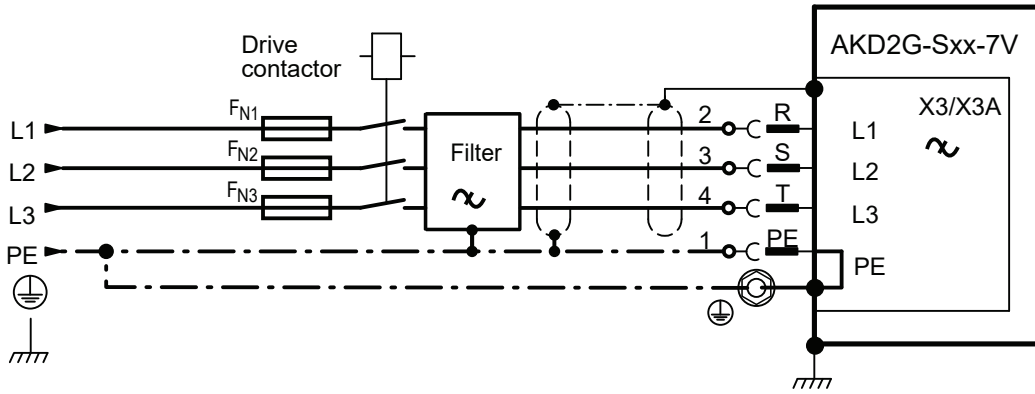

Motor Cable Length	EMI Category	
	AKD2G 3-12 A	AKD2G 24 A
< 10 m	C3	-
≥ 10 m	C2	C2

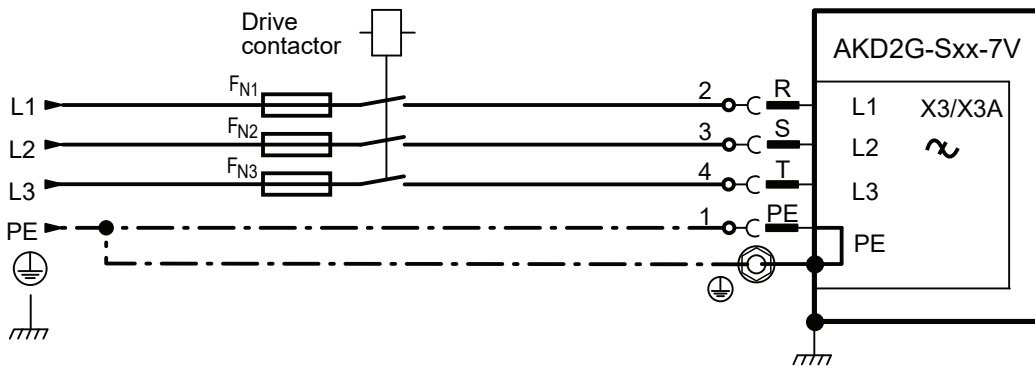

Motor Cable Length	EMI Category	
	AKD2G 3-12 A	AKD2G 24 A
< 10 m	C3	C2
≥ 10 m	-	C3

DC supply (all AKD2G-Sxx-)

- Activate DC supply (VBUS.DCOPERATION = 1) and set VBUS.DCNOMINAL.
- Any DC supply filtering for AKD2G-Sxx-6V to be provided by the user.

DC Supply to mains lines R/T (L1/L3)

DC power source is connected to the drive AC line inputs. This wiring provides soft start of the energy storage capacitors inside the drive and the AC rectifier diodes prevents motor regeneration energy from returning to the dc power source. That is, by powering the drive from the AC line input connections, the drive's energy absorption and energy dissipation mechanisms can work normally.

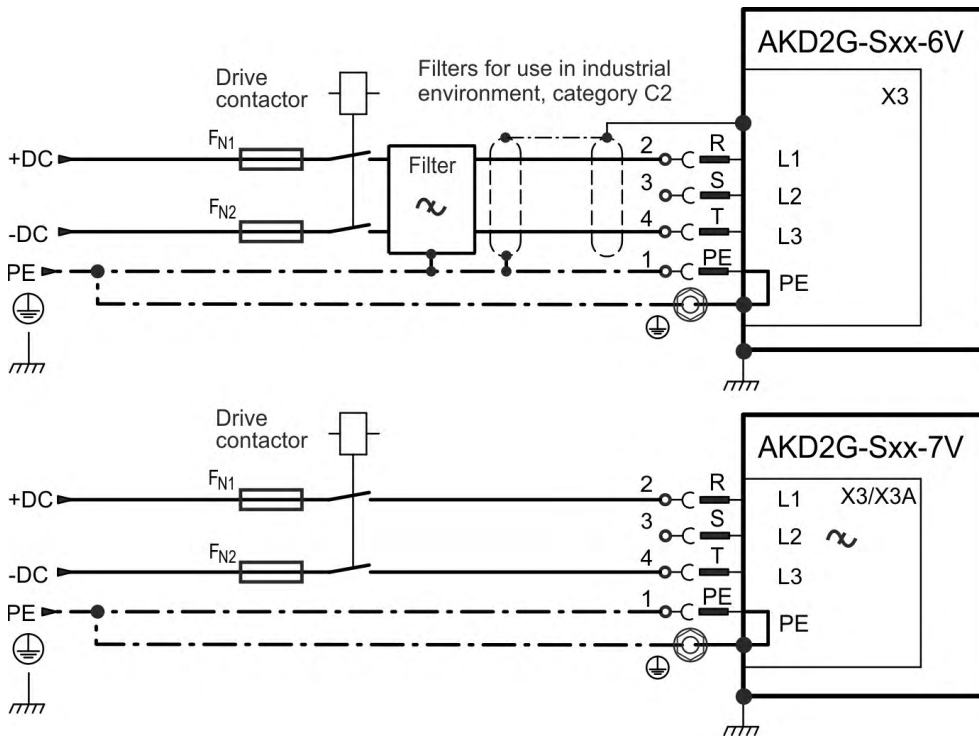

DC Supply to DC Bus lines X3/7-8

NOTICE

When wiring DC power supply to the drive DC Bus terminals X3/X3B pins 7 and 8, the user is responsible for current and power management using additional external devices. For more information refer to [KDN \(AKD2G Low Voltage DC Operation\)](#).

User responsibility:

- The power supply system design must ensure inrush current protection by limiting input current during power up.
- Provide a means to safely absorb energy from the motor when slowing down/regenerating. UL Rating for DC requires that DC is created from an AC source. Other forms of DC are not covered by the UL listing.
- DC supply polarity must be properly wired. Improper polarity of DC power will damage the drive and void warranty.

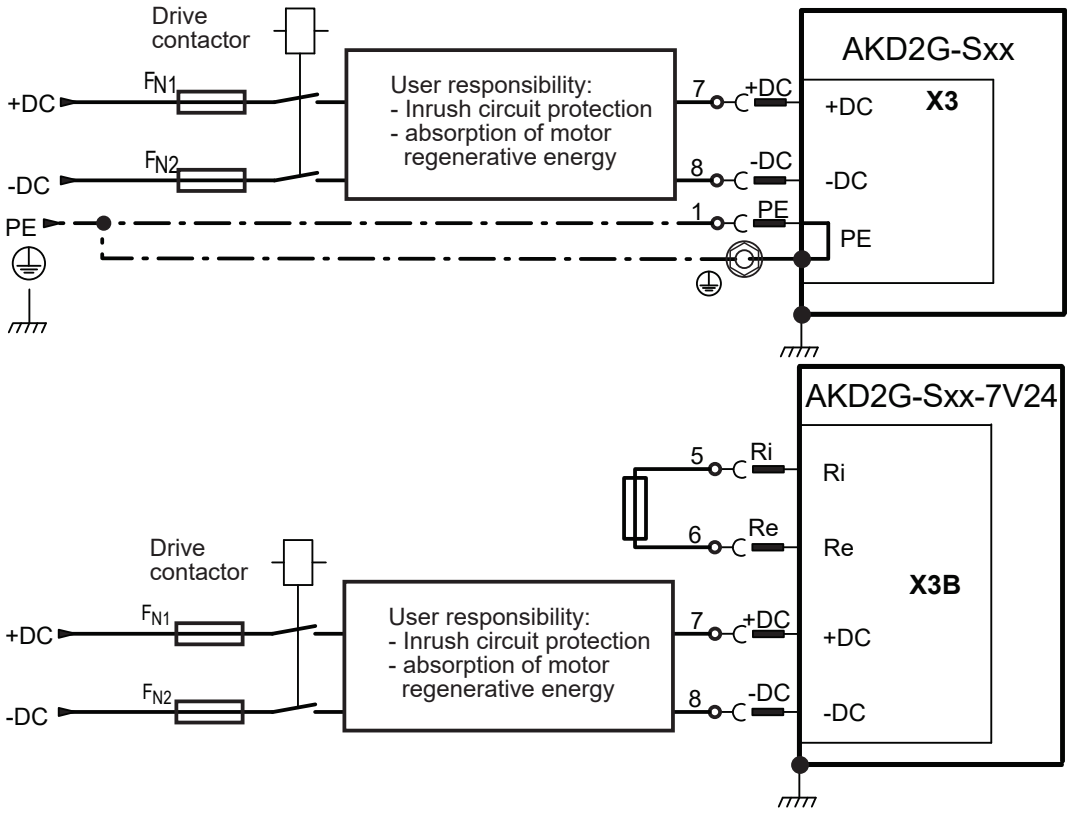

7.6.2.2 Fusing

Fuse types	Description
US fuses	<ul style="list-style-type: none"> Class J, 600 VAC, 200 kA SCCR, time-delay must be UL and CSA listed <p>Alternate fuses and breakers to Class J must have similar or better I_p and I^2T performance per UL 508A SB4.2 at max. 10 kA SCCR rating.</p>
EU fuses	<ul style="list-style-type: none"> Types gS or gG, 400 V/500 V, time-delay max. 10 kA SCCR
Semiconductor	<ul style="list-style-type: none"> max. 65 kA SCCR
Fuse holders	Use finger-safe fuse holders according to EN 60529 in combination with the standard fuse blocks.
Automatic circuit breakers	<ul style="list-style-type: none"> max. 30 A max. 10 kA SCCR
Group installation fusing	<ul style="list-style-type: none"> max. 30 A

AC supply, single drives, line fusing

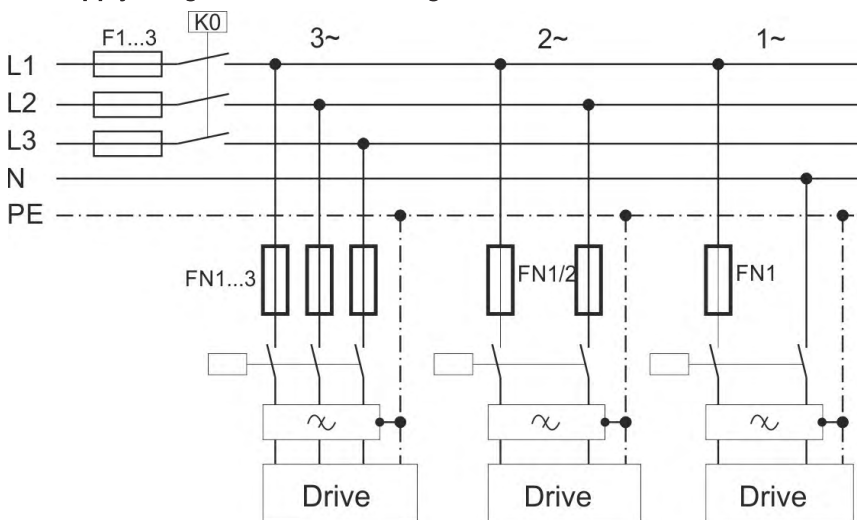

- F1, F2, F3: depends on sum of application's required input currents and cabinet requirements.
- Filters for special EMC requirements only (→ # 549).
- FN1, FN2, FN3 maximum rating: 30 A.
- FN1, FN2, FN3 recommended rating see table below:

Drive Model	FN1, FN2, FN3: Ampere rating	Example class J Eaton Bussmann	Example class J Mersen
AKD2G-Sxx-6V03S	10 A (Time-Delay)	LPJ10SP, DFJ10	AJT10, HSJ10
AKD2G-Sxx-6V06S AKD2G-Sxx-6V03D	10 A (Time-Delay)	LPJ10SP, DFJ10	AJT10, HSJ10
AKD2G-Sxx-6V12S AKD2G-Sxx-6V06D	15 A (Time-Delay)	LPJ15SP, DFJ15	AJT15, HSJ15
AKD2G-Sxx-7V03S	10 A (Time-Delay)	LPJ-10SP, DFJ-10	AJT10, HSJ10
AKD2G-Sxx-7V06S AKD2G-Sxx-7V03D	10 A (Time-Delay)	LPJ-10SP, DFJ-10	AJT10, HSJ10
AKD2G-Sxx-7V12S AKD2G-Sxx-7V06D	15 A (Time-Delay)	LPJ-15SP, DFJ-15	AJT15, HSJ15
AKD2G-Sxx-7V24S	25 A (Time-Delay)	LPJ-25SP, DFJ-25	AJT25, HSJ25
Drive Model	FN1, FN2, FN3: Ampere rating	Semi-conductor Eaton/Bussmann	Semi-conductor Mersen
AKD2G-Sxx-6V03S	10 A	FWP-10G14F	FR14GR69V10
AKD2G-Sxx-6V06S AKD2G-Sxx-6V03D	10 A	FWP-10G14F	FR14GR69V10
AKD2G-Sxx-6V12S AKD2G-Sxx-6V06D	15 A	FWP-16G14F	FR14GR69V16
AKD2G-Sxx-7V03S	10 A	FWP-10G14F	FR14GR69V10
AKD2G-Sxx-7V06S AKD2G-Sxx-7V03D	10 A	FWP-10G14F	FR14GR69V10
AKD2G-Sxx-7V12S AKD2G-Sxx-7V06D	15 A	FWP-16G14F	FR14GR69V16
AKD2G-Sxx-7V24S	32 A	FWP-32G14F	FR14GR69V32

AC supply, group of drives, line fusing

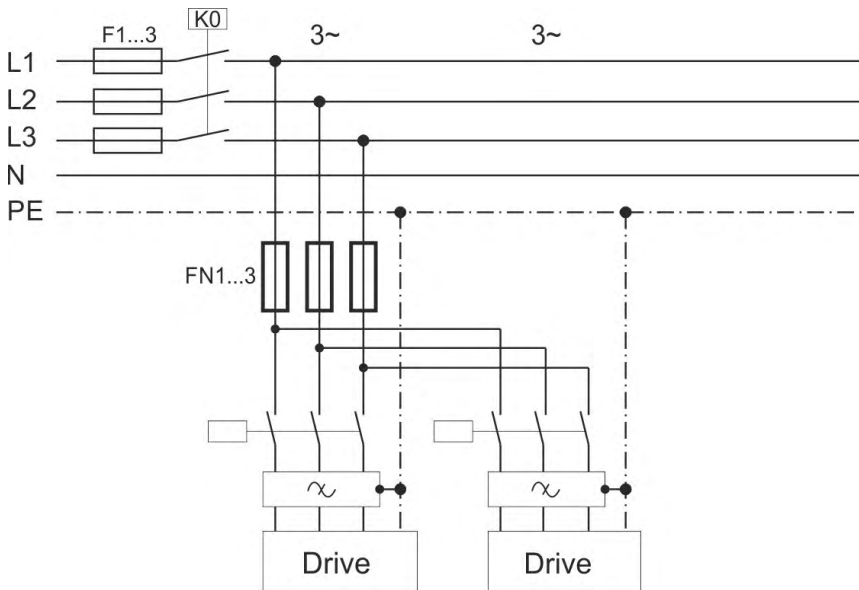

- F1, F2, F3: depends on sum of application's required input currents and cabinet requirements.
- Filters for special EMC requirements only (→ # 549).
- FN1, FN2, FN3 maximum rating: fuse size for group installation is limited to 30 A max. and 32 A max. for Semiconductor fuses.
- FN1, FN2, FN3 rating should be 1.25 * sum current.

Group sum current	FN1, FN2, FN3: Ampere rating	Eaton Bussmann	Mersen
6 A to 30 A	30 A (Time-Delay)	Example class J LPJ30SP, DFJ30	Example class J AJT30, HSJ30
	32 A	Semiconductor FWP-32G14F	Semiconductor FR14GR69V32

NOTE

The sum of the AC input currents ($A_1...n$) is less than 30 A (32 A when semiconductor fuses are used). Additionally, the sum of the axes currents ($I_1...n$) in parallel DC bus groupings must be less than 48 A. The maximum number of axes is limited to 8 drive enclosures per group installation.

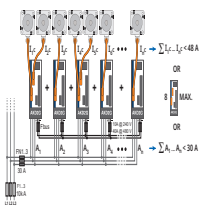

AC supply, single drives, automatic circuit breakers

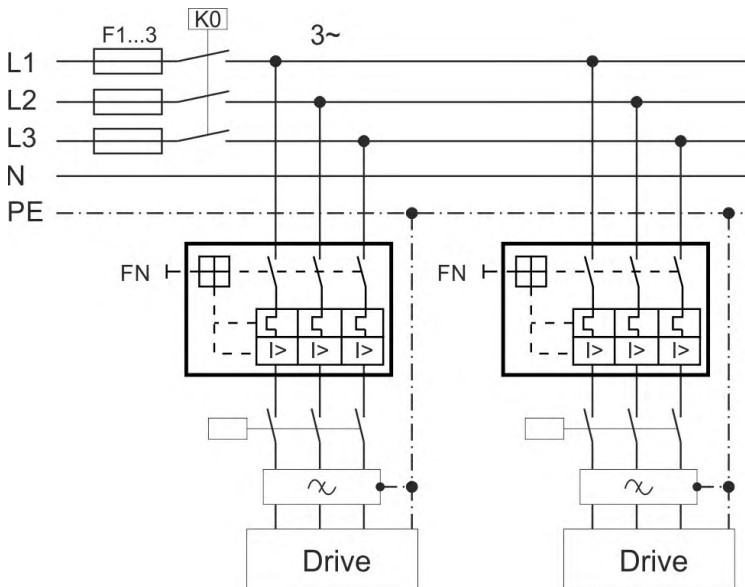

- F1, F2, F3: depends on the sum of application's required input currents and cabinet requirements.
- Filters for special EMC requirements only (→ # 549).
- FN maximum rating: 30 A
- FN recommended rating and regional approvals see table below:

Drive Model	Ampere rating	SCCR rating	Example ABB
AKD2G-Sxx-6V	15 A	10 kA	SU203M-K15
AKD2G-Sxx-7V	15 A	10 kA	SU203M-K15
AKD2G-Sxx-7V24x	30 A	10 kA	SU203M-K30

AC supply, group of drives, automatic circuit breakers

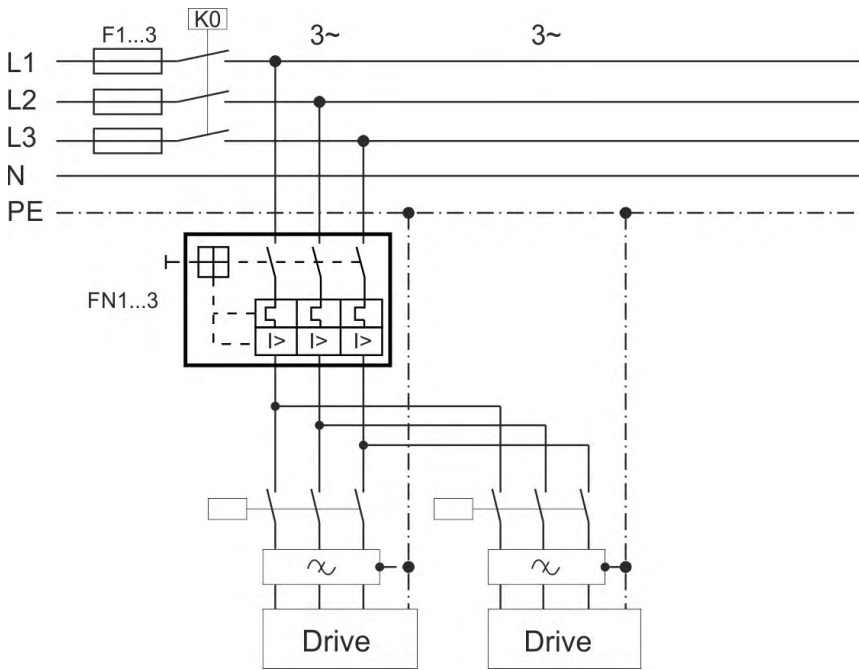

- F1, F2, F3: depends on sum of application's required input currents and cabinet requirements.
- Filters for special EMC requirements only (→ # 549).
- FN maximum rating: circuit breaker size for group installation is limited to 30 A max.
- FN rating should be 1.25 * sum current.
- FN recommended rating and regional approvals see table below:

Group sum current	Ampere rating	SCCR rating	Example UL ABB
AKD2G-Sxx-6V			
6 A to 9 A	15 A	10 kA	SU203M-K15
12 A to 15 A	20 A	10 kA	SU203M-K20
18 A to 24 A	30 A	10 kA	SU203M-K30
27 A to 36 A	30 A	10 kA	SU203M-K30
AKD2G-Sxx-7V			
6 A to 9 A	15 A	10 kA	SU203M-K15
12 A to 15 A	20 A	10 kA	SU203M-K20
18 A to 24 A	30 A	10 kA	SU203M-K30
27 A to 36 A	30 A	10 kA	SU203M-K30

DC supply, single drives, line fusing

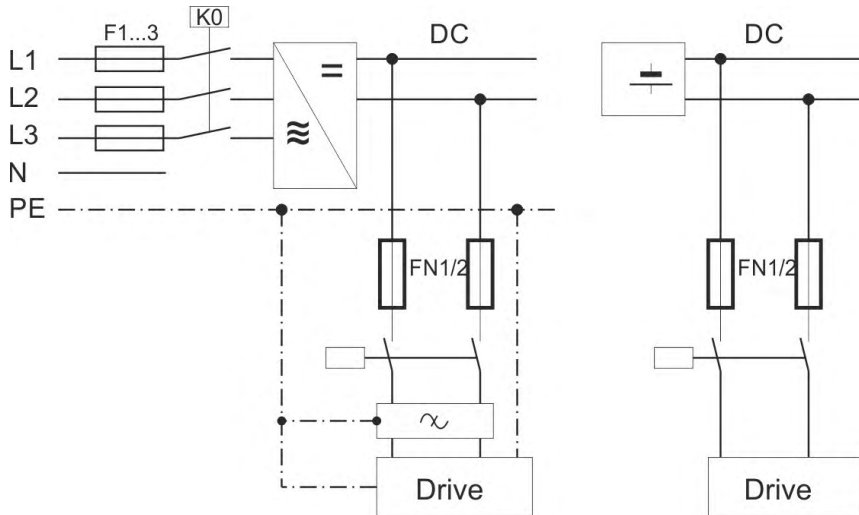

- F1, F2, F3: depends on sum of application's required input currents and cabinet requirements.
- Filters for special EMC requirements only (→ # 549).
- FN1, FN2 maximum rating 30 A
- FN1, FN2 recommended rating see table below:

Drive Model	Ampere rating	Example Eaton Bussmann	Example Mersen
AKD2G-Sxx-6V03S	10 A (Time-Delay)	DFJ-10	HP6M10
AKD2G-Sxx-6V06S AKD2G-Sxx-6V03D	15 A (Time-Delay)	DFJ-15	HP6M15
AKD2G-Sxx-6V12S AKD2G-Sxx-6V06D	15 A (Time-Delay)	DFJ-15	HP6M15
AKD2G-Sxx-7V03S	10 A (Time-Delay)	FWP-10B	HP10M10
AKD2G-Sxx-7V06S AKD2G-Sxx-7V03D	10 A (Time-Delay)	FWP-10B	HP10M10
AKD2G-Sxx-7V12S AKD2G-Sxx-7V06D	15 A (Time-Delay)	FWP-15B	HP10M15
AKD2G-Sxx-7V24S	25 A (Time-Delay)	FWP-25B	HP10M25

7.6.3 Auxiliary voltage power supply connector X10

The following diagram describes external 24 VDC power supply (PELV). The required supply current rating depends on the use of motor brake (→ # 44) or (→ # 44).



- 2 pin, pitch 5.08 mm
- T-type mating connector data (→ # 63)
- Undervoltage fault limit 19 V
- Overvoltage fault limit 30 V

Pin	Signal	Description
1	+ 24 V	+24 VDC supply voltage, PELV

Pin	Signal	Description
2	GND	Ground for 24 VDC supply voltage, PELV

For control supply current requirement specifications see section (→ # 49).

7.6.3.1 Fusing

Use 24 VDC supply manufacturer's recommendation for fusing.

7.6.3.2 Wiring example 24 VDC supply

Maximum current for one string of daisy-chained X10T connectors is 20 A. The sum of the control currents of the connected drives should not exceed 20 A. With the data given in the table above, you can connect for example: 6 single axis drives, or 4 dual axis drives, or 3 single + 2 dual axis drives.

Wiring example with three phase power supply unit:

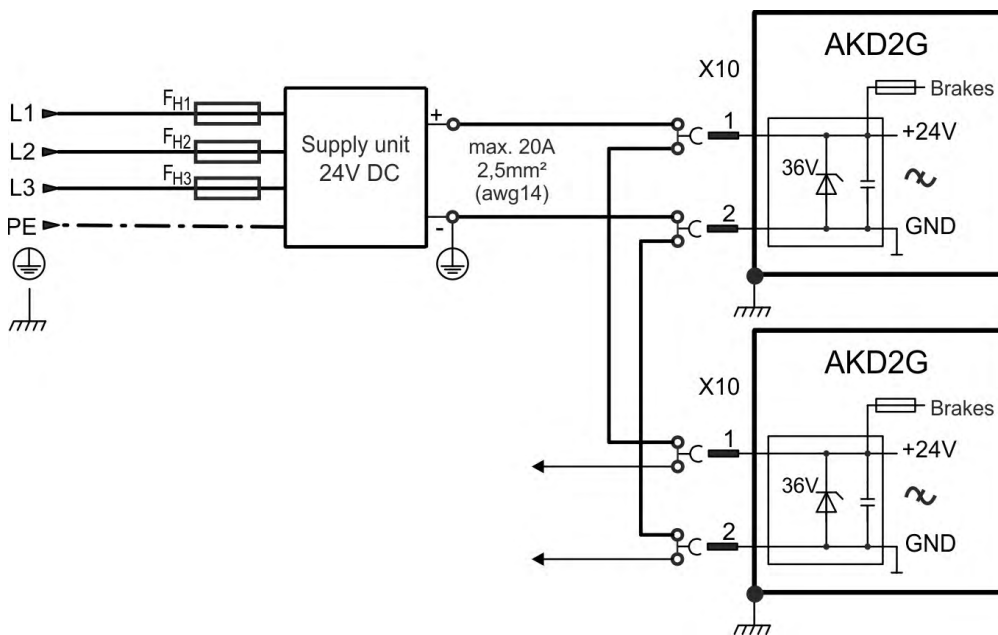

7.7 DC Bus link connector X3/X3B

The DC bus link can be connected in parallel so that the power returned from slowing down motors is divided between all the drives that are connected to the same DC bus link circuit. Every drive must have its own power connection to mains voltage sharing the same branch, over current protection devices, even if the DC bus link is used. Drives working generatively very often should be placed beside drives, which need energy. That reduces current flow on longer distances.

NOTICE

The drives can be destroyed if DC bus link voltages are different. Only drives with mains supply that share the same AC branch, over current protection devices (identical mains supply voltage) may have the DC bus links interconnected.

Interconnection of DC bus links works best in systems powered by 3-phase AC or DC power. Consult Kollmorgen for DC bus linking with single phase AC power input.

NOTE

The sum of the application currents in the connected in parallel DC bus wires must not exceed 48 A.

Wiring: Use 6 mm² unshielded single cores with a max. length of 200 mm; use 6 mm² shielded cables for longer lengths. In this case no fuse for line protection is required.

- 8/4 pin, pitch 7.62/10.16 mm
- Optional T version (not available for 7V24 drives)
- Mating connector data (→ # 63)

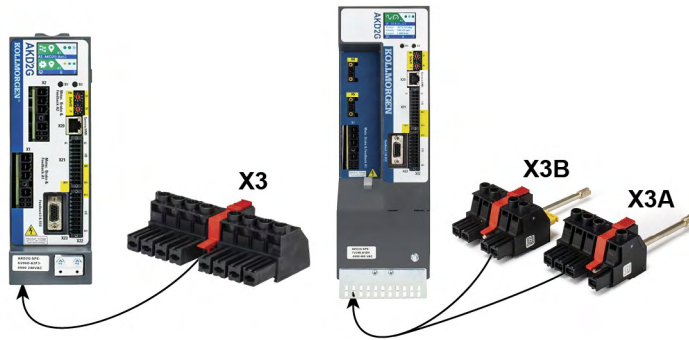

Pin	Label	Signal	Description
7	+DC	+DC	DC Bus link positive
8	-DC	-DC	DC Bus link negative

NOTE

In addition to the sum of the axes currents ($I_{1...n}$) in parallel DC bus groupings being less than 48 A, the sum of the AC input currents ($A_{1...n}$) must be less than 30 A (32 A when semiconductor fuses are used). The maximum number of axes is limited to 8 drive enclosures per group installation. Group AC fusing and breaker guidelines should also be followed for DC bus groupings. (→ # 99)

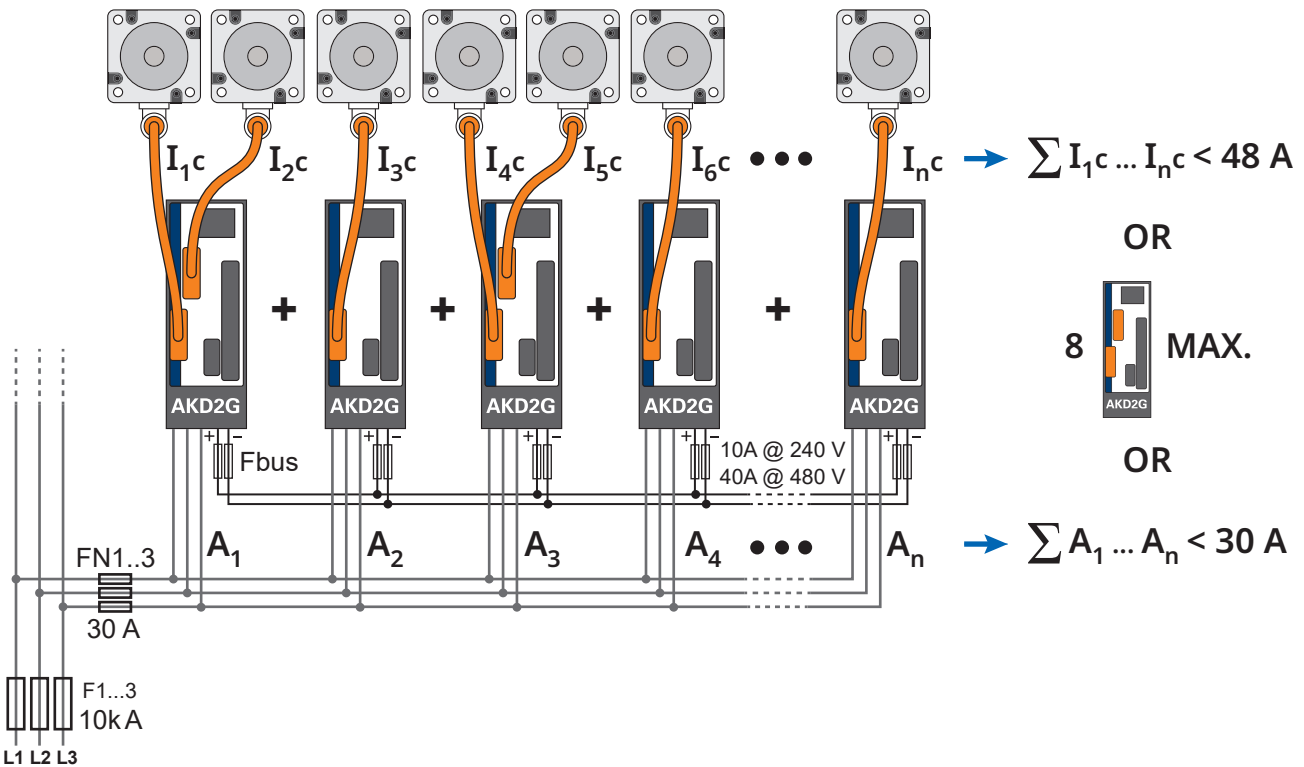

7.7.1 Fusing

External regen fusing FB1/FB2 (→ # 106). DC bus link fusing depends on topology (see (→ # 105)).

Wiring topology	Ampere rating@240V	Ampere rating@480V	Example Eaton:	Example Mersen:
AKD2G-Sxx-6V				
Group: Fgroup	max. 30 A	na	DFJ-30	HP6M30
Busbar: Fbus	max. 15 A	na	DFJ-15	HP6M15
AKD2G-Sxx-7V				
Group: Fgroup	max. 30 A		FWP-30B	HP10M30
Busbar: Fbus	max. 15 A		FWP-15B	HP10M15

NOTE Also follow group AC fusing and breaker guidelines when sharing or grouping regen resistors. (→ # 99)

7.7.2 Wiring example with T connectors

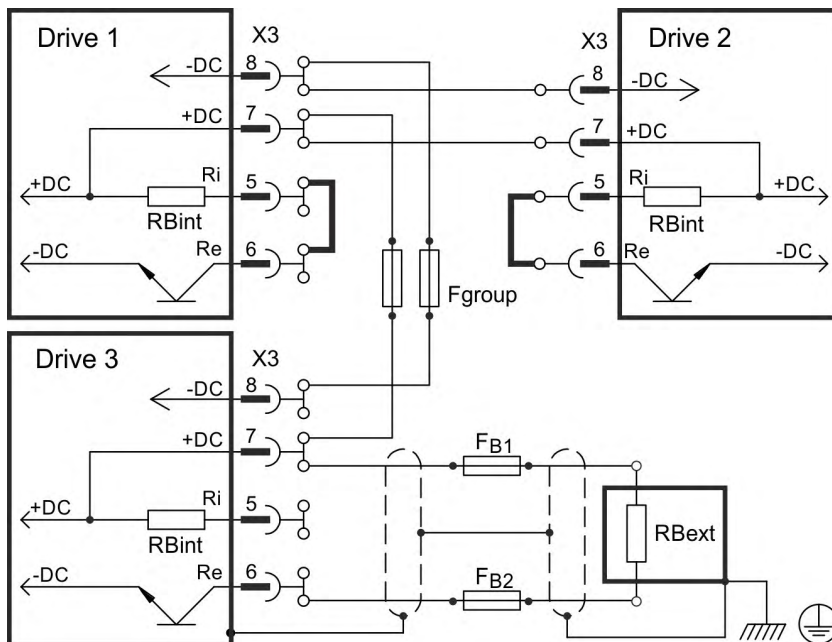

Note: T connectors are not available for 7V24 drives.

Without DC Bus fuses, other devices can become damaged or destroyed if, for example, a device fails due to an internal short circuit. If multiple drives are connected in parallel, then it is usual to insert DC Bus fuses (Fgroup) between groups of drives (with a group consisting of two or three devices, depending on the current) in order to limit any possible resulting damage. Fgroup fuses cannot avoid damage by current peaks completely.

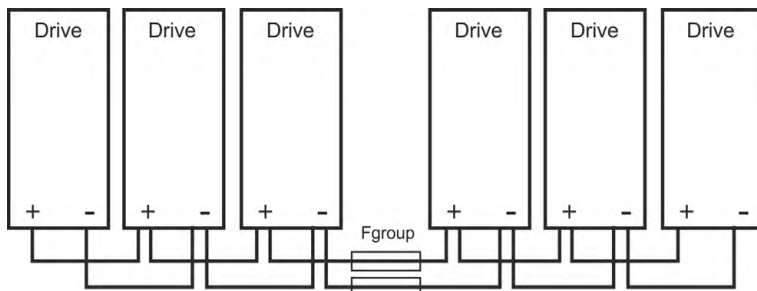

7.7.3 Wiring example with busbar

If a device fails in this system due to a short-circuit, only its fuses (Fbus) are tripped and the rest of the network continues uninterrupted. The solid busbars can conduct significantly larger currents than T connectors, because the compensating current does not flow through the connector as above.

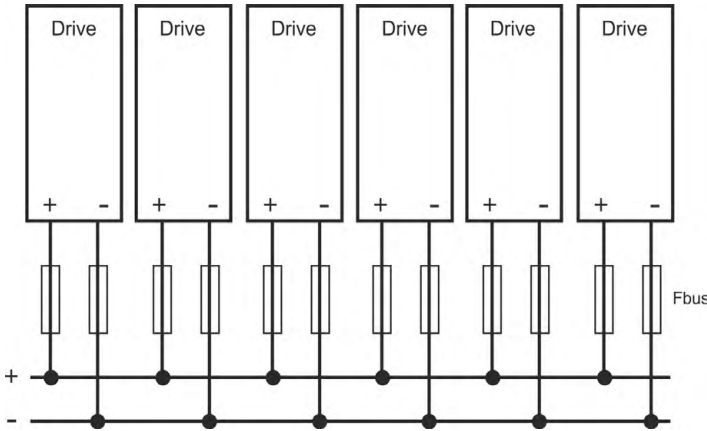

7.8 Regen resistor connector X3/X3B

For technical data on the regenerative brake circuit (→ # 49).

NOTE Fusing (such as fusible cut-outs or power switches) to be provided by the user.

- 8/4 pin, pitch 7.62/10.16 mm
- Optional T version (not available on 7V24S model)
- Mating connector data (→ # 63).
- X3/5 to X3/6 must be shorted to use the built in regen resistor. Remove the jumper to connect an external regen resistor.
- Refer to the WorkBench online help for parameter setting (REGEN.EXT, REGEN.REXT, REGEN.WATTEXT)

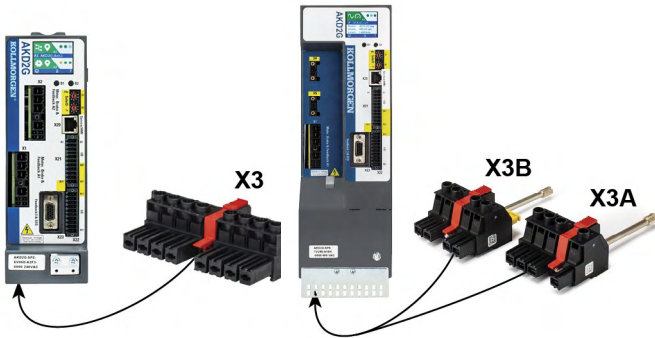

Pin	Label	Signal	Description
5	Ri	RBint	internal Regen resistor
6	Re	-RB	external Regen resistor -
7	+DC	+RBext	external Regen resistor +

7.8.1 Fusing and Wiring

FB1 / FB2 fusing

Drive Model	Ampere rating@240V	Ampere rating@480V	Example: Eaton	Example: Siba
all AKD2G-Sxx	10A	40A	FWP-xxA14F	110V to 400V: gRL(gS) 400V to 480V: aR

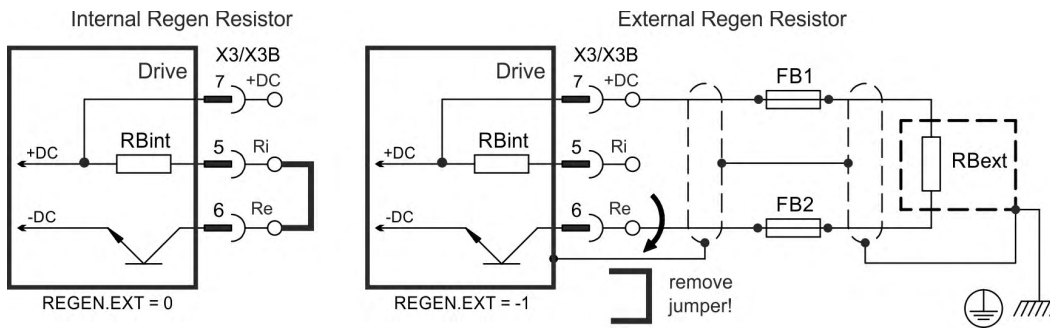

7.9 Motor Power, Brake and Feedback connection

The AKD2G drive is able to protect the connected motor from overloading, if the parameters are set correctly and the thermal protection sensor is connected and supervised. With Kollmorgen motors the valid data are automatically set by the WorkBench motor database. Refer to parameter AXIS#.MOTOR.RTYPE for supported thermal sensors.

NOTICE

The dynamic voltage rise can lead to a reduction in the motor operating life and, on unsuitable motors, to flashovers in the motor winding.

- Only install motors with insulation class F (acc. to IEC60085) or above.
- Only install cables that meet the requirements (→ # 64).

7.9.1 Motor connectivity, some examples

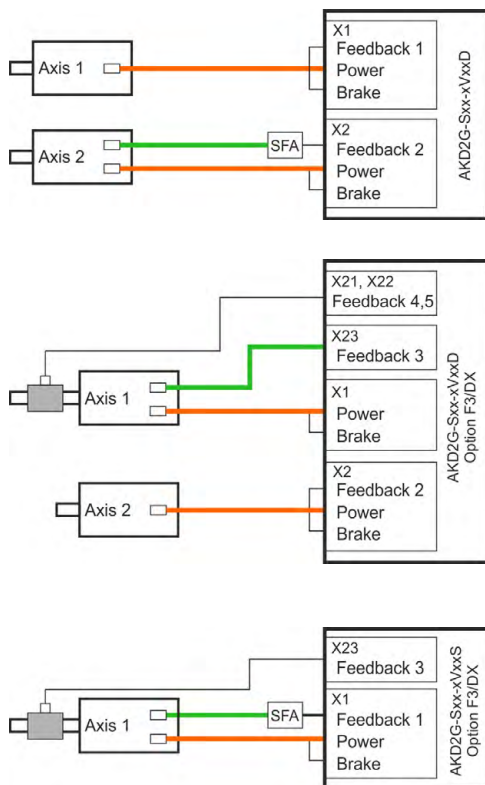

- Axis 1: single cable connection (→ # 108)
 - commutation feedback: SFD3 or DSL
- Axis 2: dual cable connection (→ # 108)
 - commutation feedback: EnDAT, HIPERFACE, Resolver etc. by using SFA
- Axis 1: dual cable connection (→ # 110)
 - commutation feedback: Resolver, SFD, EnDAT, HIPERFACE, BiSS, SinCos, ComCoder, Hall, SmartAbs etc. by using X23
 - position feedback:
 - X21: Step/Direction
 - X22: Step/Direction or incremental encoder
- Axis 2: single cable connection (→ # 108)
 - commutation feedback: SFD3 or DSL
- Axis 1: dual cable connection (→ # 110)
 - commutation feedback: EnDAT, HIPERFACE, Resolver etc. by using SFA
 - position feedback: Resolver, SFD, EnDAT, HIPERFACE, BiSS, SinCos, ComCoder, Hall, SmartAbs etc. by using X23

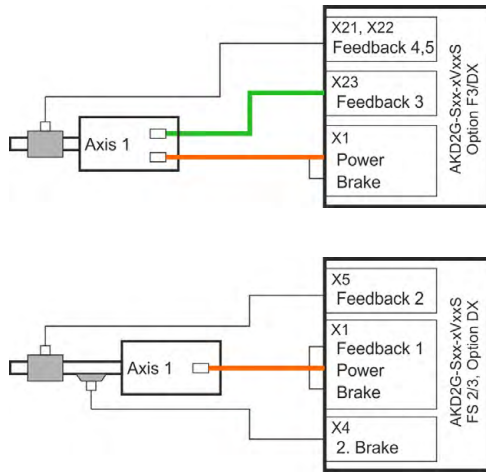

- Axis 1: dual cable connection (→ # 110)
 - commutation feedback: Resolver, SFD, EnDAT, HIPERFACE, BiSS, SinCos, ComCoder, Hall, SmartAbs etc. by using X23
 - position feedback:
 - X21: Step/Direction
 - X22: Step/Direction or incremental encoder
- Axis 1: single cable connection (→ # 108)
 - commutation feedback: SFD3 or DSL
 - position feedback: SFD3 or DSL or SFA at X5
 - secondary brake by using X4

7.9.2 Single motor cable connection

Motors with two wire feedback systems like SFD3 or Hiperface DSL can be connected to AKD2G by using a single Kollmorgen hybrid cable. Depending on the AKD2G version (single or dual axis), one or two single cable motor connections are possible.

Drive type	Commutation Axis 1	Commutation Axis 2	2nd Brake	Velocity/Position loop closure			
Single axis with Option F3	X1	-	X4	X5	X21	X22	X23
Dual axis with Option F3	X1	X2	-	-	X21	X22	X23

7.9.2.1 Motor Power, Brake and Feedback connectors X1, X2

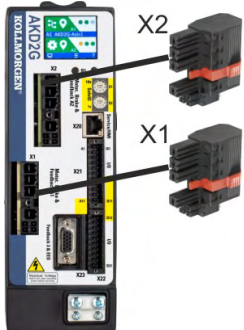

- X1 (Feedback 1) / X2 (Feedback 2)
 - Motor Power: 4 pin, pitch 7.62 mm
 - Motor Brake: 2 pin, pitch 3.81 mm
 - Motor Feedback: 2 pin, pitch 3.81 mm
- Cable length: (→ # 64)
- Use Kollmorgen cables
- Mating connector data (→ # 63).
- Feedback types: SFD3, HIPERFACE DSL
 - Rated voltage 11 V.
 - Rated current is 350 mA simultaneously for X1 and X2.

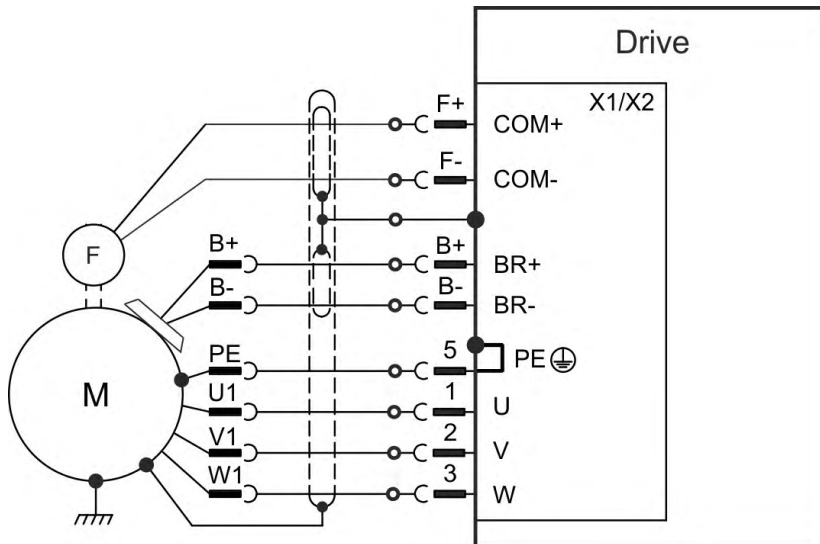

Pinout is identical for connectors X1 and X2.

Pin	Signal	Description
1	U	Motor phase U
2	V	Motor phase V
3	W	Motor phase W
5	PE	Protective earth
B+	BR+	Brake positive line (safety notes and details (→ # 113))
B-	BR-	Brake negative line (safety notes and details (→ # 113))
F+	COM+	SFD3, HIPERFACE DSL
F-	COM-	

7.9.2.2 Feedback connectors X5, X41, X21, X22, X23

- Velocity/Position loop closing
- Use Kollmorgen cables
- Mating connector data (→ # 63).
- Cable length: (→ # 64)

Connector	Functionality	Pinout, Wiring
X5	For single axis drives only. SFD3, DSL, SFA	(→ # 119)
X41	SFA at X5, several conventional feedback types	(→ # 137)
X21	Step/Direction, CW/CCW	(→ # 120)
X22	Step/Direction, CW/CCW, Incr.Encoder, EnDAT, BiSS	(→ # 121)
X23	Several conventional feedback types	(→ # 122)

7.9.2.3 Secondary Brake connector X4

Connector X4 is standard on single axis drives with functional safety and is used for applications that require a second safety brake.

- Mating connector data (→ # 63).
- Cable length: (→ # 64)

Connector	Functionality	Pinout, Wiring
X4	For single axis drives only	(→ # 115)

7.9.3 Dual motor cable connection

Motors with conventional commutation feedback systems like resolver or sine encoder can be connected to AKD2G with separated power/brake and feedback cables. Feedback functions are assigned with parameters in WorkBench. Scaling and other settings are performed in WorkBench, too. Velocity / Position loop closing and electronic gearing / master-slave connection are possible by using X5, X21, X22, X23 depending on the drive version and physical restrictions.

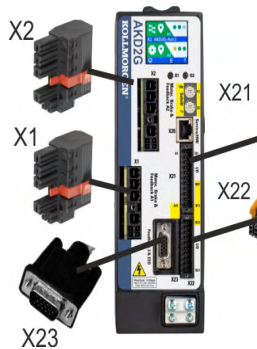

- X1 (Feedback 1) / X2 (Feedback 2)
 - Motor Power: 4 pin, pitch 7.62 mm
 - Motor Brake: 2 pin, pitch 3.81 mm
 - SFA connection: 2 pin, pitch 3.81 mm
 - Feedback types: see SFA connectivity (→ # 137)
- X23 (Feedback 3)
 - SubD HD 15 poles
 - Feedback types: see X23 connectivity (→ # 122)
- X21 (Feedback 4)
 - 2 x 11 pins (left connector A, right connector B)
 - Feedback types: see X21 connectivity (→ # 120)
- X22 (Feedback 5)
 - 2 x 10 pins (left connector A, right connector B)
 - Feedback types: see X22 connectivity (→ # 121)
- Mating connector data (→ # 63).

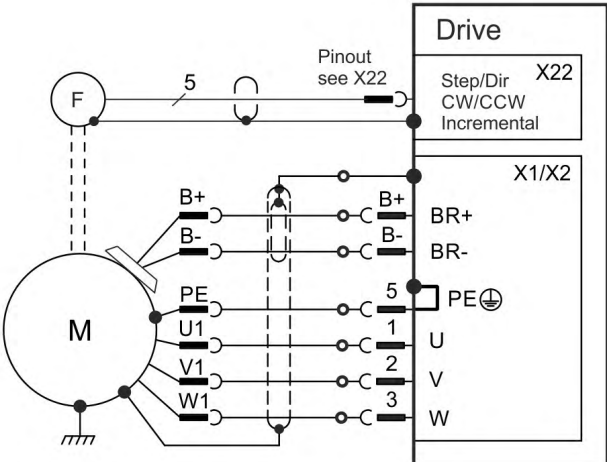
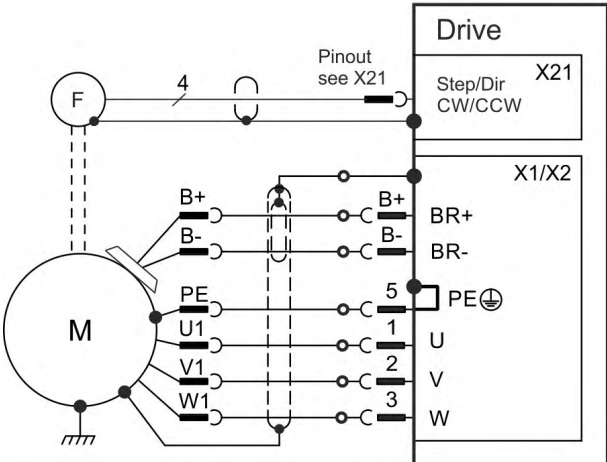
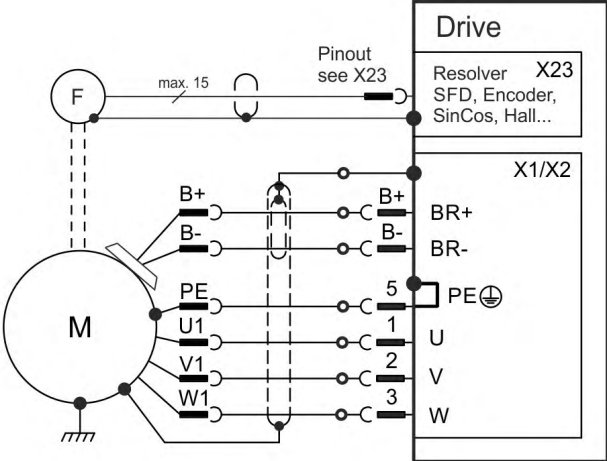
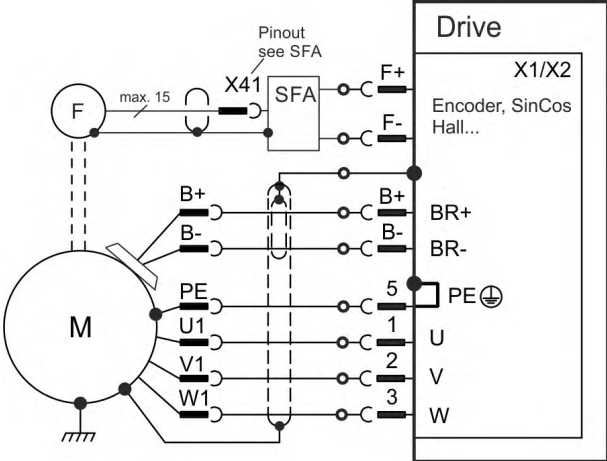

7.9.3.1 Motor power and motor brake connectors X1, X2

Usually these lines are part of the Kollmorgen motor cable connected to X1 or X2. For motor brake safety notes and functional details (→ # 113).

- Use Kollmorgen cables
- Mating connector data (→ # 63).
- Cable length: (→ # 64)

Pin	Signal	Description
1	U	Motor phase U
2	V	Motor phase V
3	W	Motor phase W
5	PE	Protective earth
B+	BR+	Brake positive, with Kollmorgen cables only
B-	BR-	Brake negative, with Kollmorgen cables only

7.9.3.2 Feedback connectors X1, X2, X5, X41, X21, X22, X23

- Use Kollmorgen cables
- Mating connector data (→ # 63).
- Cable length: (→ # 64)
- For feedback connection overview (→ # 116)

Connector	Functionality	Pinout, Wiring
X1/X2	SFD3, DSL, SFA	(→ # 118)
X5 (only on 24 A model)	For single axis drives only. SFD3, DSL, SFA	(→ # 119)
X41	SFA at X1 or X2 or X5, several conventional feedback types	(→ # 137)
X21	Step/Direction, CW/CCW	(→ # 120)
X22	Step/Direction, CW/CCW, Incr. Encoder, EnDAT, BiSS	(→ # 121)
X23	Several conventional feedback types	(→ # 122)

Feedback connector X1, X2, X5, X41

Conventional feedback systems can be connected to X1 or X2 or X5 by using the optional feedback adapter SFA. SFA offers the additional connector X41.

- X1 is a standard connector. Input for SFD3, DSL, or SFA.
- X2 is standard for dual-axis drives. Input for SFD3, DSL, or SFA.
- X5 is optional for single axes drives. Input for SFD3, DSL, or SFA.
- SFA: adapter for several conventional feedback types

Feedback connector X21

- Connector X21 is a standard connector.
- Input for Step/Direction and CW/CCW.

Feedback connector X22

- Connector X22 is standard connector .
- Input for Step/Direction, CW/CCW, Incremental encoder

Feedback connector X23

- Connector X23 is part of option F3.
- Input for several conventional feedback types.

7.9.3.3 Secondary Brake connector X4

Connector X4 is part of the single axis drive. Use for applications, which require a second safe brake for functional safety.

- Mating connector data: (→ # 63).
- Cable length: (→ # 65)

Connector	Functionality	Pinout, Wiring
X4	For single axis drives only	(→ # 115)

7.9.4 Motor Holding Brake Connection

A 24 V holding brake in the motor can be controlled directly by the drive. For proper function, check voltage drop, measure voltage at brake input and check brake function (on and off).

Brake voltage supply by using 24 V \pm 10% auxiliary voltage supply of the drive on X10. Minimum and maximum brake current see Electrical Data (→ # 46) respectively (→ # 48).

AKD2G offers motor brake outputs on connectors X1, X2 and X4. The outputs can be mapped to the required axis with WorkBench.

Connector	Usable for
X1	Primary motor brake axis 1 or secondary brake for axis 2
X2	Primary motor brake axis 2 or secondary brake for axis 1
X4	Secondary motor brake axis 1, for single axis drives only (→ # 115)



WARNING No functional safety!

Serious injury could result when the load is not properly blocked. The internal brake function does not ensure functional safety.

- Functional Safety can be ensured with configured SBC (→ # 240) only.
- For SIL 3 a second (external) motor brake for an axis is required. For single axis drives this brake can be connected to X4 (→ # 115). For dual axis drives the additional brake must be controlled from another source (e.g. from the other axis or externally from a safety controller). The brakes can be mapped to an axis with WorkBench.
- The Hardware Enable does not initiate a controlled stop but switches off the power stage immediately.
- Set parameter `AXIS#.MOTOR.BRAKEIMM` to 1 with vertical axes, to apply the brake immediately after faults or Hardware Disable.

Pinout X1 / X2

Pin	Signal	Description
B+	BR+	Brake positive line
B-	BR-	Brake negative line

Wiring

Usually the brake lines are part of Kollmorgen cable connections to X1 and X2 (→ # 108).

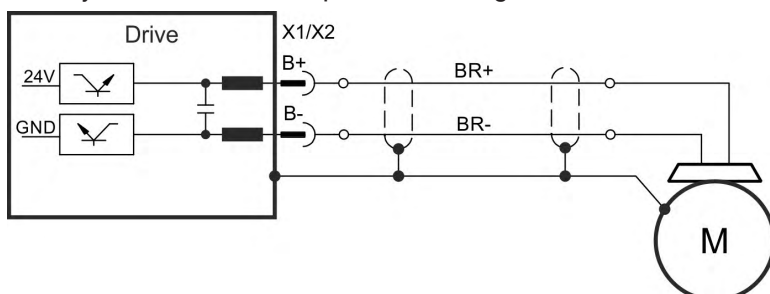

Functionality

The brake function must be enabled through a parameter. The diagram below shows the timing and functional relationships between the controlled stop signal, speed, and braking force. All values can be adjusted with parameters; values in the diagram are default values.

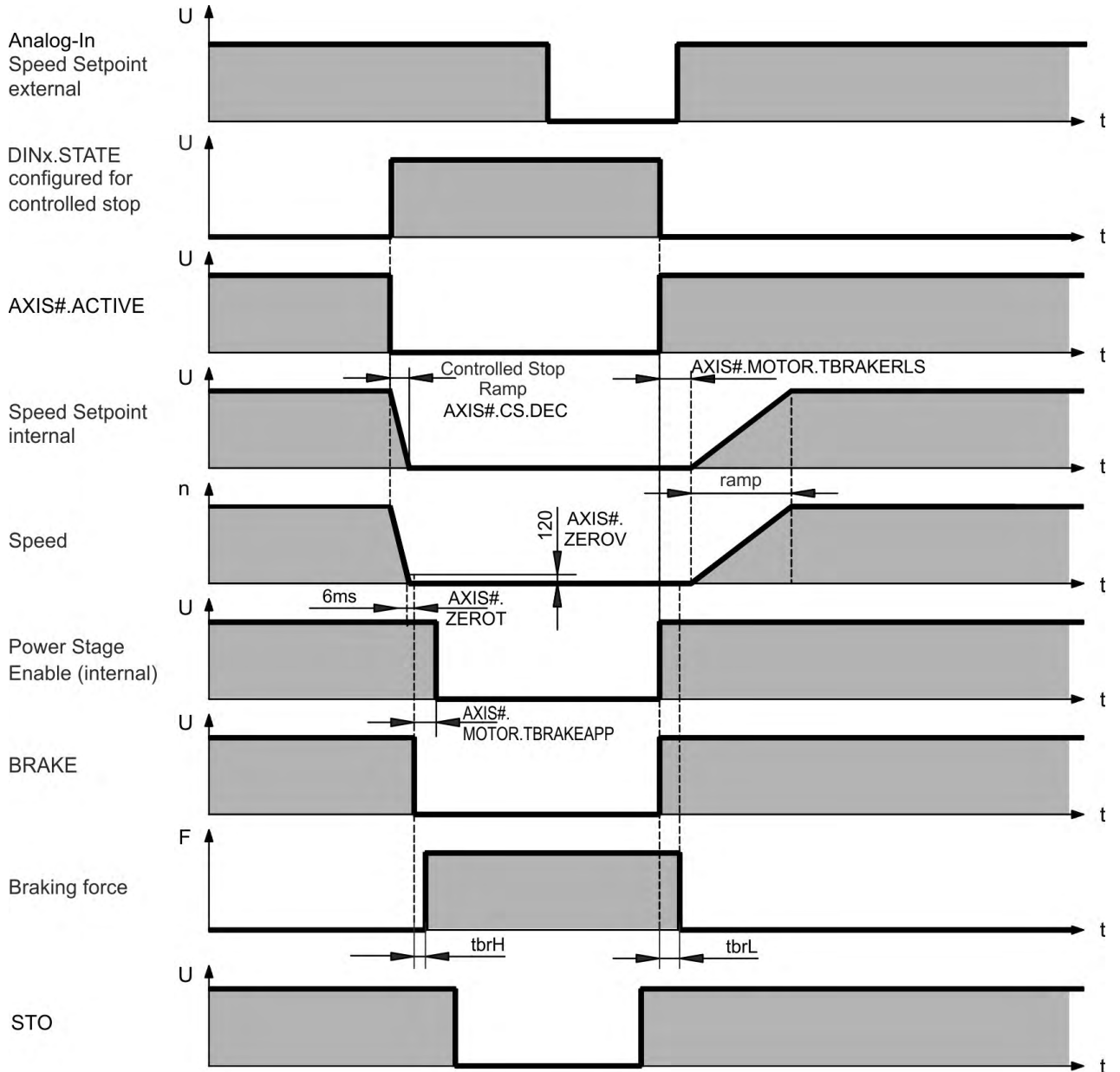

The drive speed setpoint is internally driven down an adjustable ramp (AXIS#.CS.DEC) to 0 V.

With default values the output for the brake is switched on when the speed has reached 5 rpm (AXIS#.ZEROV) for at least 6 ms (AXIS#.ZEROT). The rise (t_{brH}) and fall (t_{brL}) times of the holding brake that is built into the motor are different for the various types of motor.

7.9.4.1 Secondary Brake connector X4

Connector X4 is standard on single axis drives with functional safety and is used for applications that require a second safety brake.

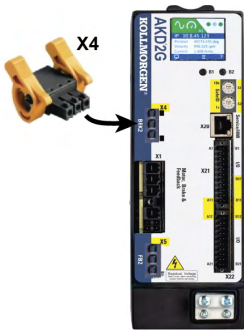

- 3 pin, pitch 3.81 mm
- Second (safe) motor brake
- Required for SIL3 brake control
- Mating connector data (→ # 63).

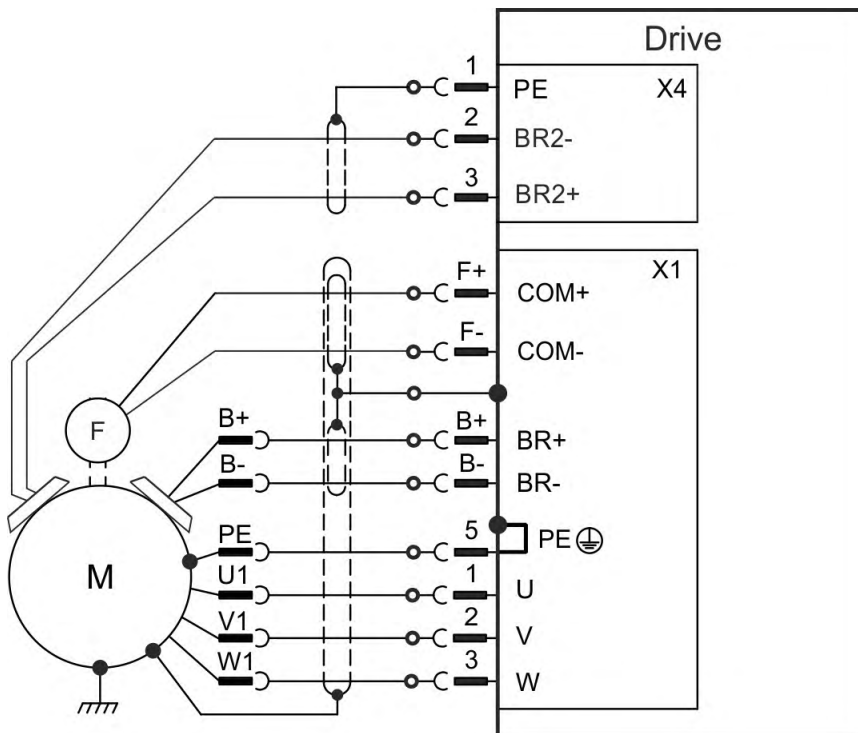

X4 Pin	Signal	Description
1	PE	Protective earth
2	BR2-	Second (external) brake -
3	BR2+	Second (external) brake +

7.10 Feedback Connection

7.10.1 Overview

AKD2G offers up to five feedback channels which can serve

- to commutate the motor (single cable (→ # 108) or dual cable (→ # 113)),
- to close the velocity and/or position loops,
- to act as a command source (electronic gearing, flying sheer, master-slave (→ # 151)),

The usage of the five channels may be freely configured in software, subject only to a few restrictions that are not physically sensible.

- Exactly one feedback channel per axis can commutate the motor.
- At most one feedback channel per axis can serve as the command source and the same feedback channel cannot also commutate the motor.
- A feedback channel can serve as the command source for more than one axis.
- FB1 cannot commutate axis 2. FB2 cannot commutate axis 1.

There are different variants of some encoders such as BiSS and SSI. Setups with third-party encoders should be tested in advance.

7.10.2 Feedback to Connector

Feedback channel	Connector	Usable for	Pinout
Feedback 1	X1	Axis 1: commutation feedback	(→ # 118)
	X41	Axis 1 by using SFA on X1: commutation feedback	(→ # 137)
Feedback 2	X2	Axis 2: commutation feedback	(→ # 118)
Feedback 2	X41	Axis 2 by using SFA on X2: commutation feedback	(→ # 137)
Feedback 2	X5	Single axis drive: velocity/position, command, safety	(→ # 119)
Feedback 2	X41	Single axis drive using SFA on X5: velocity/position, command, safety	(→ # 137)
Feedback 3	X23	commutation feedback, velocity/position, command	(→ # 122)
Feedback 4	X21	commutation feedback, velocity/position, command	(→ # 120)
Feedback 5	X22	commutation feedback, velocity/position, command	(→ # 121)

7.10.3 Feedback Type to Connector

Feedback Types	Connectors
SFD3	X1, X2, X5
Encoder HIPERFACE DSL	X1, X2, X5
Resolver	X23, X41
SFD	X23, X41
SinCos Encoder BiSS B (analog)	X23, X41
Encoder BiSS C (digital)	X22, X23, X41
SinCos Encoder EnDat 2.1	X23, X41
Encoder EnDat Digital 2.2	X22, X23, X41
Encoder HIPERFACE	X23, X41
Sine Encoder	X23, X41
Sine Encoder + Hall	X23, X41
Incremental Encoder	X21, X22, X23, X41

Feedback Types	Connectors
Incremental Encoder + Hall (Comcoder)	X23, X41
Hall Sensors	X23, X41
SSI	X22, X23, X41
Step/Direction	X21, X22, X23
CW/CCW	X21, X22, X23

7.10.4 Maximum Cable Lengths by Feedback Type

Feedback Type	Single motor cable?	Up to 265 VAC / 375 VDC	Up to 528 VAC / 750 VDC
Resolver	No	100	100
SFD Gen 2 (4 wire)	No	50	50
SFD Gen 2 (4 wire)	Yes	50	35
SFD Gen 3 (2 wire)	Yes	50	25
Hiperface DSL	Yes	25	25
BiSS (B) Analog	No	50	50
BiSS (C) Digital	No	35	25
EnDat (2.1) Analog	No	50	50
EnDat (2.2) Digital	No	50	50
Hiperface Analog	No	50	50
1 Vpp with/without Hall	No	35	25
Inc Dig with/without Hall	No	35	25
Hall Only	No	35	25
SSI	No	35	25

Max. cable lengths in m.

7.10.5 Feedback Connectors X1, X2

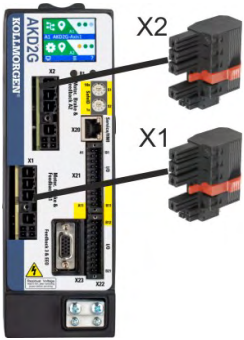

- 4 pin, pitch 7.62 mm + 2x2 pin, pitch 3.81 mm
- Input for commutation feedback: SFD3, DSL, SFA

Wiring example SFD3 or HIPERFACE DSL

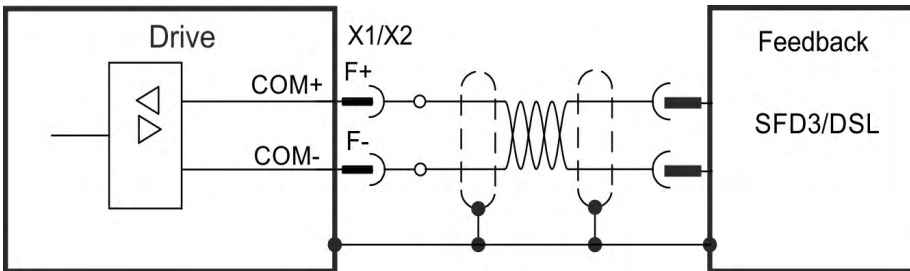

Wiring example conventional Feedback types with SFA

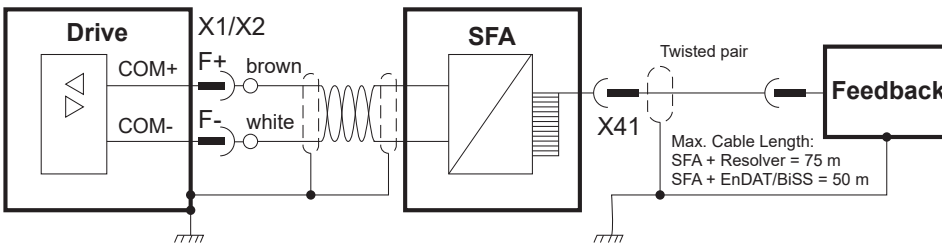

Electrical data

- Rated voltage 11 V.
- Rated current is 350 mA simultaneously for X1 and X2.

Pin	Signal	Description
F+	COM+	SFD3 +, HIPERFACE DSL +, SFA +
F-	COM-	SFD3 -, HIPERFACE DSL -, SFA -

7.10.6 Feedback Connector X5

Connector X5 is part of the single axis drives. Use this input for applications which require a safe feedback.

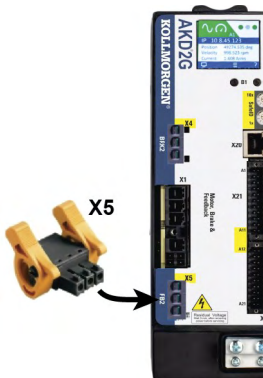

- 3 pin, pitch 3.81 mm
- Second 2 wire feedback, SFA
- Input for safe feedback.
- Feedback types: SFD3, HIPERFACE DSL
- Required for SIL3 feedback control
- Mating connector data (→ # 63).



Wiring example SFD3 or HIPERFACE DSL

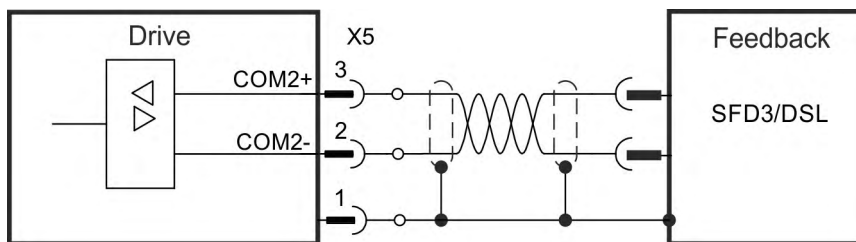

Wiring example conventional Feedback types with SFA

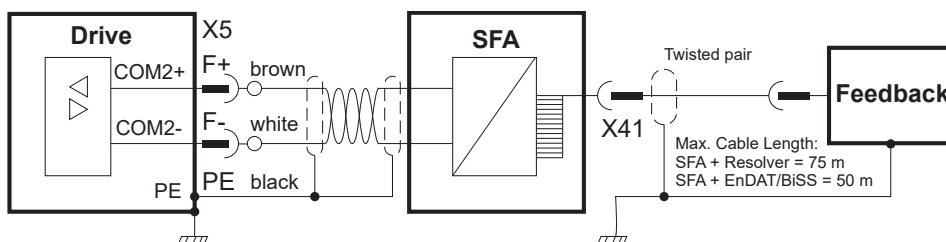

See the SFA X41 connector pinout summary and available feedback pinouts starting on (→ # 137).

X5 Pin	Signal	Description
1	PE	Cable shield (PE)
2	COM2-	Safe HIPERFACE DSL - or SFD3 - or SFA-
3	COM2+	Safe HIPERFACE DSL + or SFD3 + or SFA+

7.10.7 Feedback Connector X21



- 2 x 11 pins (left connector A, right connector B), pitch 3.5mm
- Fast input, isolated, sink, type EN 61131-2 type 1
- Input for commutation or position feedback.
- Input for Electronic Gearing, (→ # 151)
- Mating connector data (→ # 63).

Wiring example

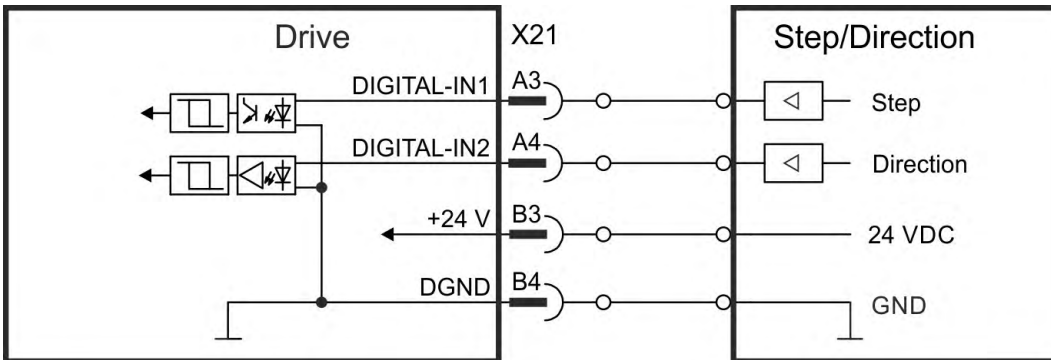

X21 Pin	Step/Direction	CW/CCW	Incr. Encoder
A3	Step	CW	A
A4	Direction	CCW	B
B3	24 VDC	24 VDC	24 VDC
B4	Common (DGND)	Common (DGND)	Common (DGND)

7.10.8 Feedback Connector X22



X21

- 2 x 10 pins (left connector A, right connector B), pitch 3.5 mm
- RS485 inputs
- Input for commutation or position feedback.
- Input for Electronic Gearing, (→ # 151)
- Output for encoder emulation (EEO2), (→ # 151)
- Mating connector data (→ # 63).

Wiring example (Input)

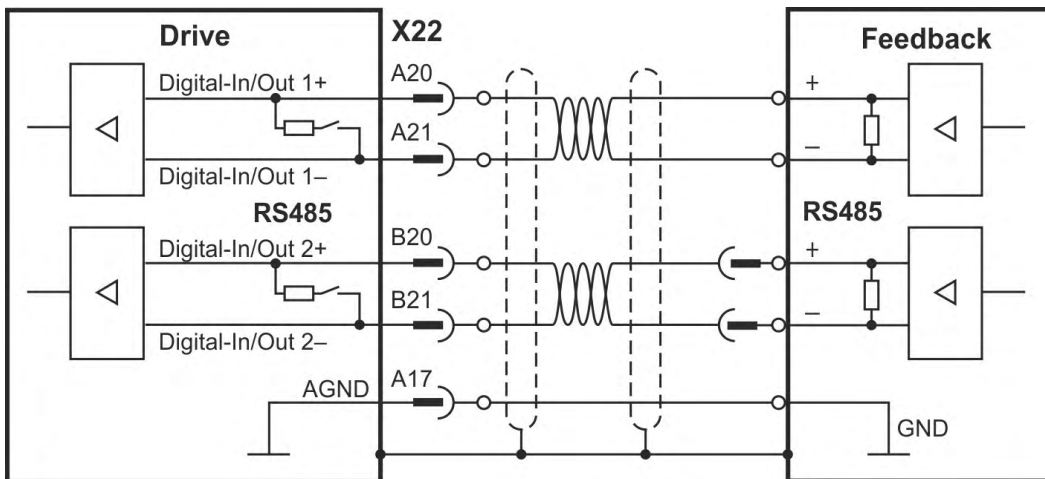

EEO output connection is similar.

X22 Pin	Step / Direction	CW / CCW	Increm. Encoder	BiSS C	EnDAT 2.2	SSI
A20	Step +	CW +	Track A +	CLK+	CLK+	CLK+
A21	Step -	CW -	Track A -	CLK-	CLK-	CLK-
B20	Direction +	CCW +	Track B +	DAT+	DAT+	DAT+
B21	Direction -	CCW -	Track B -	DAT-	DAT-	DAT-
A17	AGND	AGND	AGND	AGND	AGND	AGND

■ = DC Terminated, can be overridden with [DIO#.TERM](#)

NOTE

Feedback power supply must be supplied and controlled by the user.

7.10.9 Feedback Connector X23

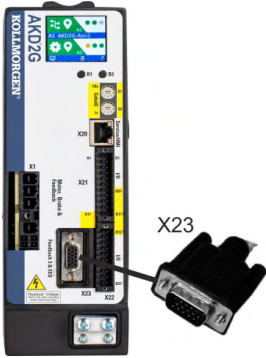

- Sub-D high density 15 pin, female
- Use Kollmorgen feedback cables
- Input for several feedback types
- Input for Electronic Gearing, (→ # 151)
- Output for encoder emulation (EEO1), (→ # 151)
- Digital input (→ # 166), Digital output (→ # 171)
- Mating connector data (→ # 63).

7.10.9.1 X23 Connector Pinout Summary

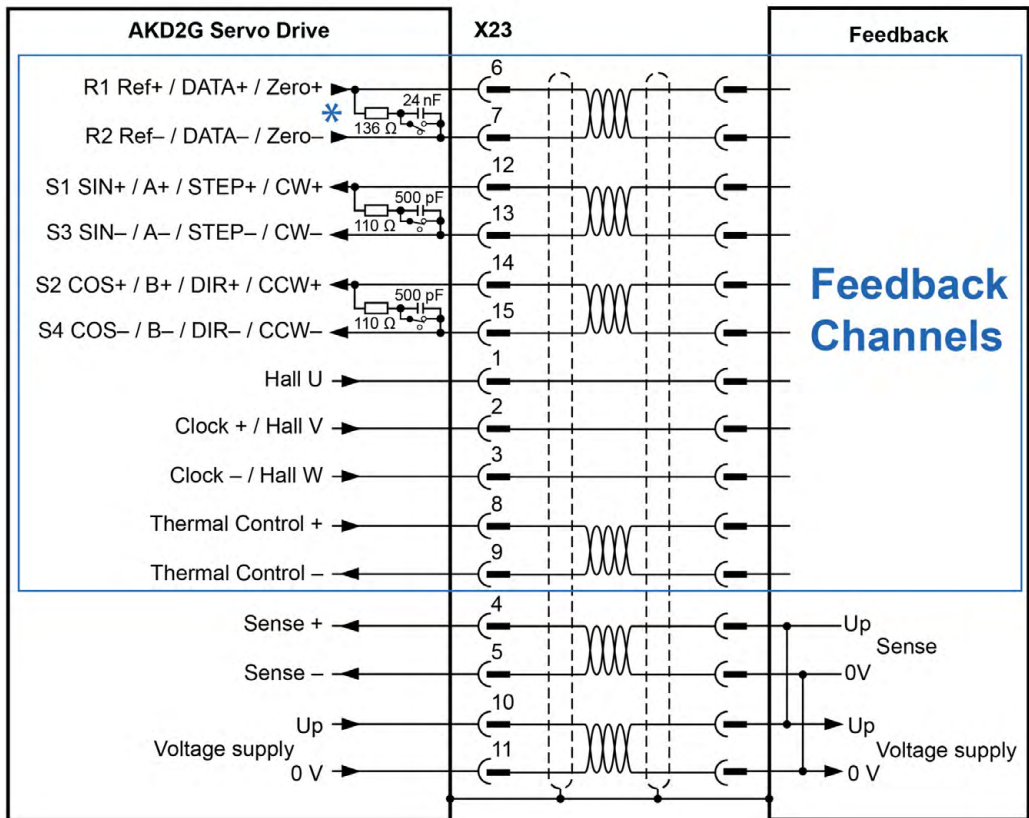

* AC / DC Selectable Termination: Older drives may not include a DC termination switch across pins 6 and 7. Please contact Kollmorgen Support for more information

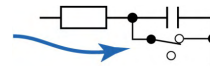

Encoder power supply (X23 pins 10/11):

- Maximum voltage 9 V with shorted sense contacts (4/5), rated voltage 5 V +/-3.5%.
- Rated supply current is 350 mA.
- Voltage rise time ~4 ms with full load and 220 µF of capacitance.
- Encoder power lines capacitance 10 µF to 220 µF

Pin	SFD	Resolver	BiSS B	BiSS C	EnDat [®] 2.1	EnDat [®] 2.2*	HIPERFACE [®]	Sine/ Cos	Sine/ Cos +Hall	Incr. Enc.	Incr. Enc. +Hall	Hall	SSI	Step/ Dir	CW/ CCW
1	-	-	-	-	-	-	-	-	Hall U	-	Hall U	Hall U	-	-	-
2	-	-	CLK+	CLK+	CLK+	CLK+	-	-	Hall V	-	Hall V	Hall V	-	-	-
3	-	-	CLK-	CLK-	CLK-	CLK-	-	-	Hall W	-	Hall W	Hall W	-	-	-
4	SEN+	-	SEN+	SEN+	SEN+	SEN+	I	SEN+	SEN+	SEN+	SEN+	-	-	-	-
5	SEN-	-	SEN-	SEN-	SEN-	SEN-		SEN-	SEN-	SEN-	SEN-	SEN-	-	-	-
6	COM+	R1 Ref+	DAT+	DAT+	DAT+	DAT+	DAT+	Zero+	Zero+	Zero+	Zero+	-	D+	-	-
7	COM-	R2 Ref-	DAT-	DAT-	DAT-	DAT-	DAT-	Zero-	Zero-	Zero-	Zero-	-	D-	-	-
8	Th+	Th+	Th+	Th+	Th+	Th+	Th+	Th+	Th+	Th+	Th+	-	Th+	Th+	Th+
9	Th-	Th-	Th-	Th-	Th-	Th-	Th-	Th-	Th-	Th-	Th-	-	Th-	Th-	Th-
10	+5 V	-	+5 V	+5 V	+5 V	+5 V	8-9 V	+5 V	+5 V	+5 V	+5 V	+5 V	+5 V	+5 V	+5 V
11	0 V	-	0 V	0 V	0 V	0 V	0 V	0 V	0 V	0 V	0 V	0 V	0 V	0 V	0 V
12	-	S1 SIN+	A+	-	A+	-	SIN+	A+	A+	A+	A+	-	-	Step+	CW+
13	-	S3 SIN-	A-	-	A-	-	SIN-	A-	A-	A-	A-	-	-	Step-	CW-
14	-	S2 COS+	B+	-	B+	-	COS+	B+	B+	B+	B+	-	-	CCW+	CCW+
15	-	S4 COS-	B-	-	B-	-	COS-	B-	B-	B-	B-	-	-	CCW-	CCW-

CL = CLOCK, D = DATA, S = SENSE, Th = Thermal control, Z = Zero

 = DC Terminated, can be overridden with DIO#. [TERMDIO#.TERM](#)

 = Optional

 = Information digitally communicated on COM+/- channel.

7.10.10 X23 Feedback Wiring Pinout Diagrams

7.10.10.1 X23 SFD Feedback

The diagram below shows the connection of the four-wire Kollmorgen SFD feedback system.

NOTE

When SFD cable total resistance for 5V out (Up) and 5V return (0V) is less than 3.3 Ohm, then remote sensing is not needed. For a typical cable this means remote sensing is not needed up to 25m.

Kollmorgen cables are rated up to 50m with no remote sensing.

Type	FBx.IDENTIFIED	Up	Description
Smart Feedback Device (SFD)	41	5.1 V \pm 3.5%	Accuracy: 14 bit (0.022°), resolution: 24 bit (2x10E-5°)

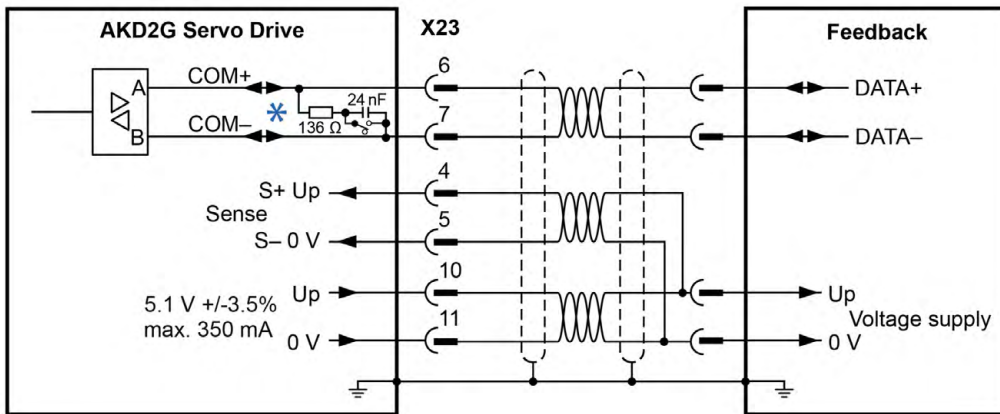

* SFD must always use AC coupled termination - DC termination switch open.

7.10.10.2 X23 Resolver Feedback

The diagram below shows the connection of a resolver (2 to 36-poles) as a feedback system. The thermal control in the motor is connected via the Resolver cable and evaluated in the drive. If no thermal control is in the motor, the cable must short pins 8 and 9.

If cable lengths of more than 100m are planned, please contact customer support.

Type	FBx.INDENTIFIED	Description
Resolver	40	Accuracy: 14 bit (0.022°), resolution: 16 bit (0.006°), frequency (fixed): 6875 Hz

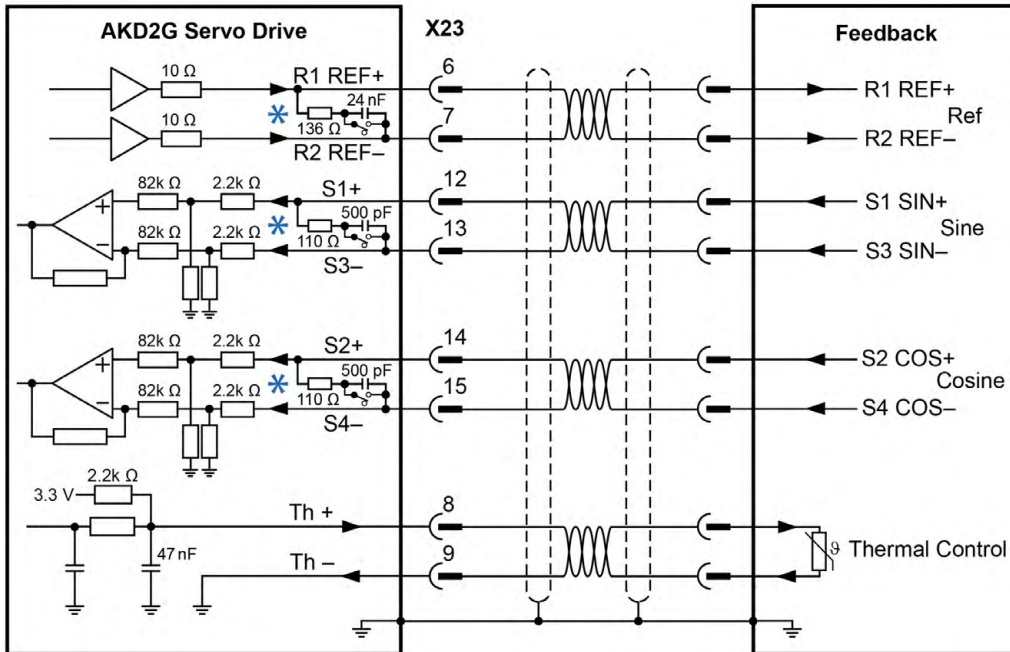

- * Resolver Sine/Cosine channels must be high impedance - DC termination switch open.
- * DC termination is not compatible with the REF channel - DC termination switch open.

7.10.10.3 X23 BiSS (Mode B) Analog Feedback

The diagram below shows the wiring of a single-turn or multi-turn encoder with BiSS Mode B interface as a feedback system. The thermal control in the motor is connected via the encoder cable and evaluated in the drive.

If cable lengths of more than 50m are planned, please consult customer support.

Type	FBx.INDENTIFIED	Up	Frequency Limit
BiSS (Mode B) Analog	32	5.1 V \pm 3.5%	1 MHz, 250 kHz for encoders that require termination resistors

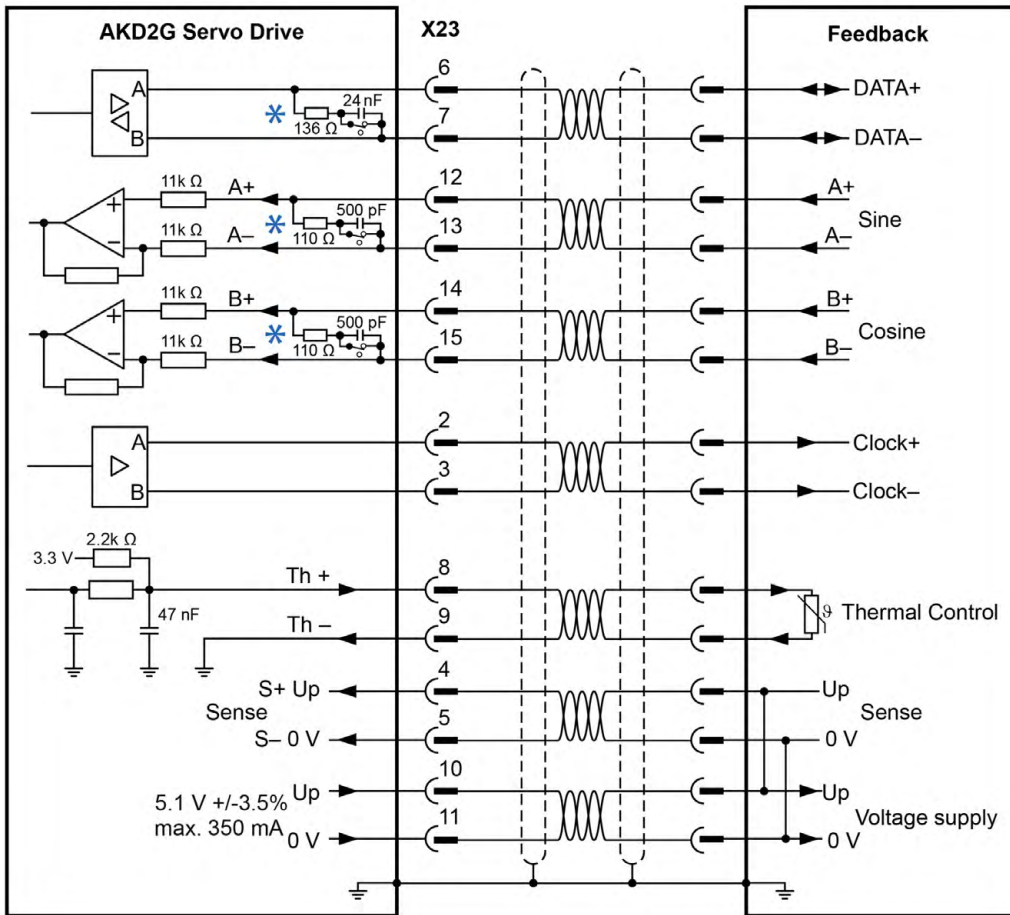

* DC terminated by default - DC switch closed.

7.10.10.4 X23 BiSS (Mode C) Digital Feedback

The diagram below shows the wiring of a single-turn or multi-turn encoder with BiSS Mode C interface from Renishaw (specifically model Resolute RA26B) as a feedback system.

If cable lengths of more than 25m are planned, please consult customer support.

Type	FBx.INDENTIFIED	Up	Frequency Limit
BiSS (Mode C) Digital	34	5.1 V \pm 3.5%	1 MHz

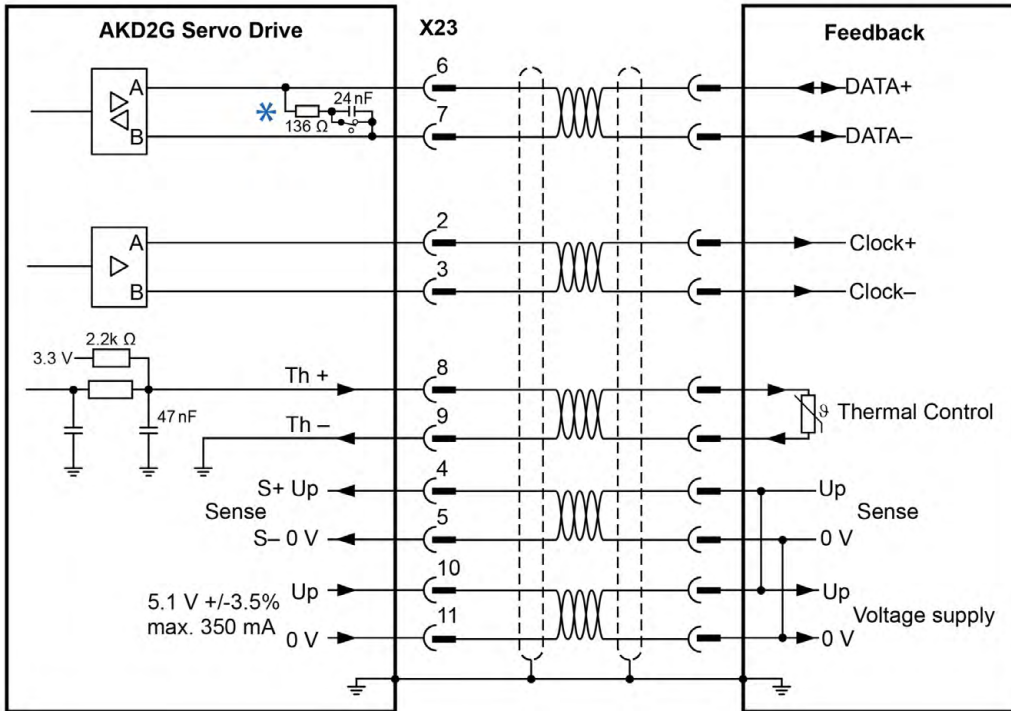

* DC terminated by default - DC switch closed.

7.10.10.5 X23 EnDAT 2.1 Feedback (with 1V p-p analog signals)

The diagram below shows the wiring of a single-turn or multi-turn sine-cosine encoder with EnDat 2.1 interface as a feedback system. Preferred types are the ECN1313 and EQN1325 encoders. The thermal control in the motor is connected via the encoder cable and evaluated in the drive. All signals are connected using our pre-assembled encoder connection cable.

If cable lengths of more than 50m are planned, please consult customer support.

Type	FBx.INDENTIFIED	Frequency Limit
EnDAT 2.1	30	1 MHz, 250 kHz for encoders that require termination resistors

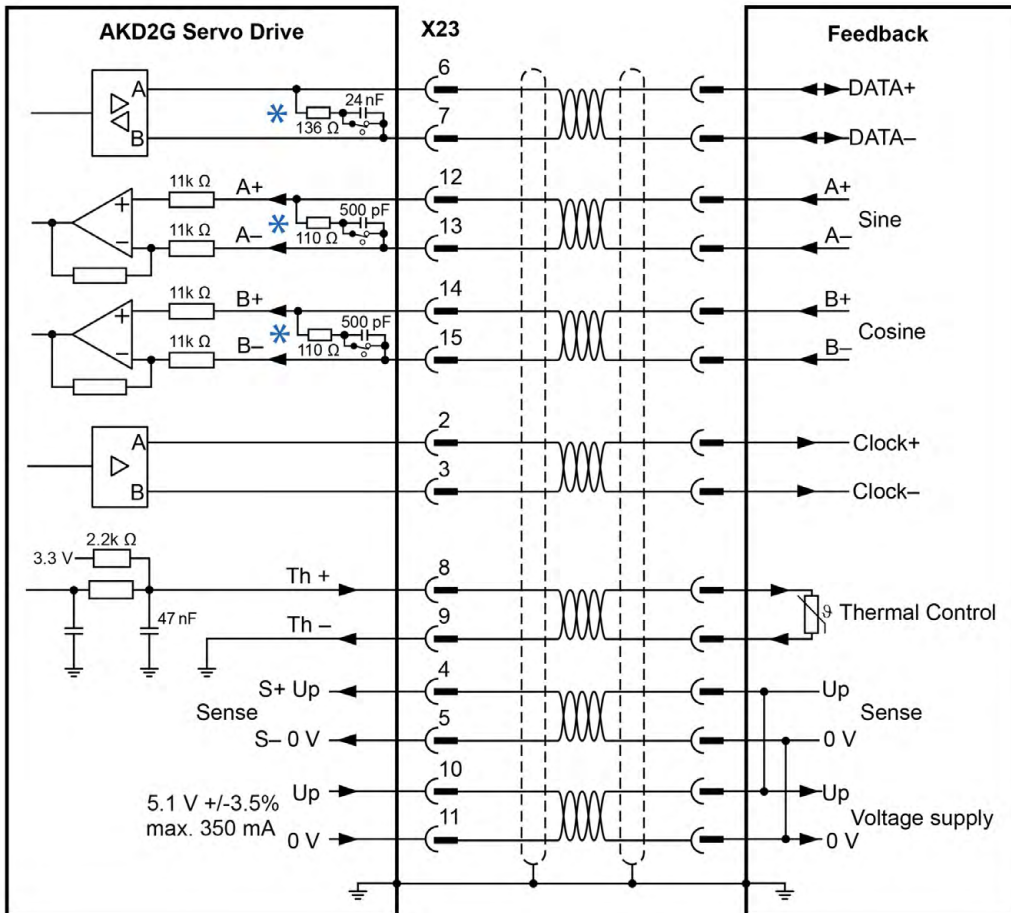

* DC terminated by default - DC switch closed.

7.10.10.6 X23 EnDAT 2.2 Digital Feedback

Single-turn or multi-turn encoders with EnDat 2.2 interface can be connected either to X23 or X41 as a primary motor feedback system.

All signals are connected using our pre-assembled encoder connection cable.

If cable lengths of more than 50m are planned, please consult customer support.

Type	FBx.INDENTIFIED	Frequency Limit
EnDAT 2.2	31	2.5 MHz

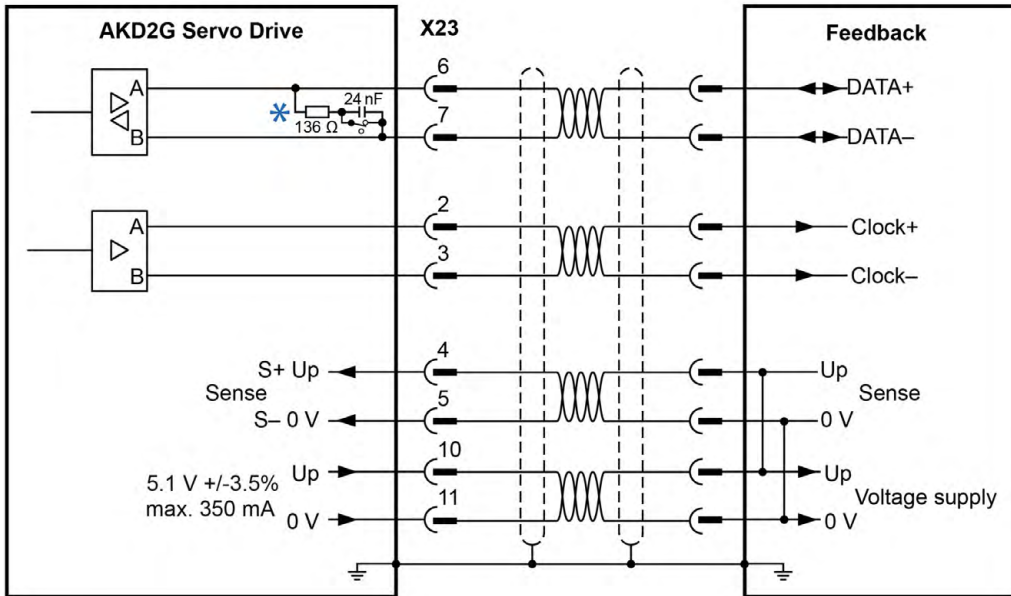

* DC terminated by default - DC switch closed.

NOTE

From AKD: Analog I/O functionality must be selected in the related WorkBench screen. If the set limit is exceeded, then warning n256 is created.

*For use as primary motor feedback, set parameters DRV.EMUEMODE, PL.FBSOURCE, IL.FBSOURCE, VL.FBSOURCE.

7.10.10.7 X23 HIPERFACE Feedback

The diagram below shows the wiring of a single-turn or multi-turn sine-cosine encoder with Hiperface interface as a feedback system.

The thermal control in the motor is connected via the encoder cable and evaluated in the drive. All signals are connected using our pre-assembled encoder connection cable.

If cable lengths of more than 50 m are planned, please consult customer support.

Type	FBx.INDENTIFIED	Frequency Limit
HIPERFACE	33	1 MHz, 250 kHz for encoders that require termination resistors

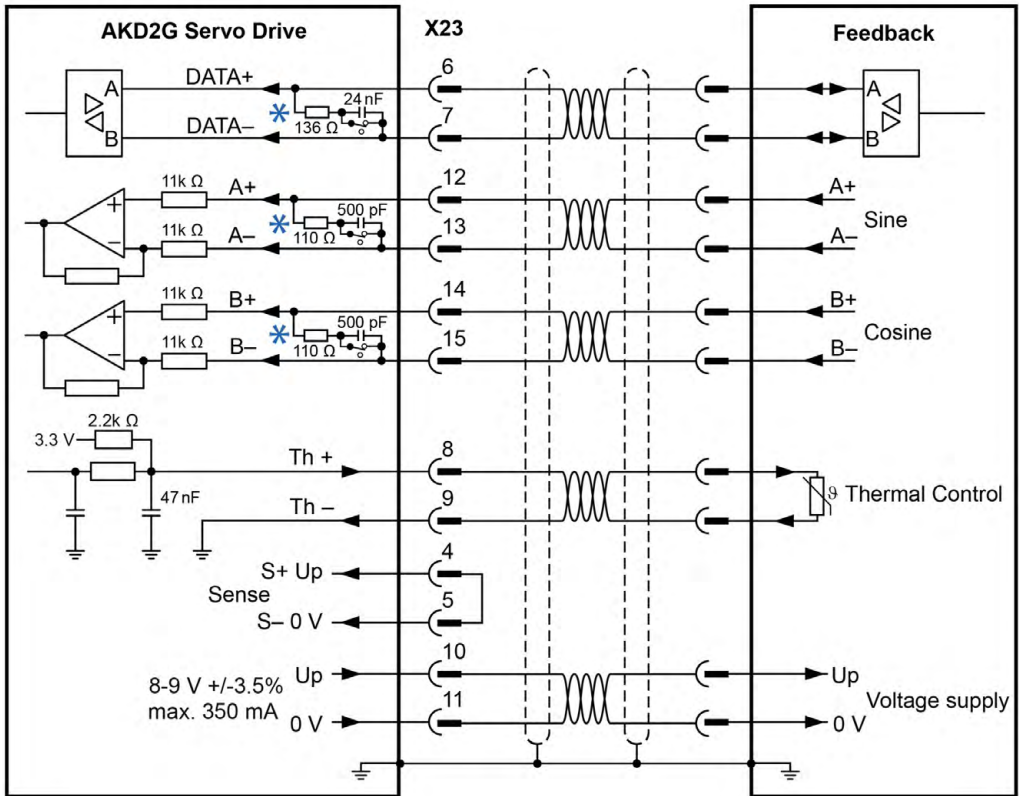

* DC terminated by default - DC switch closed.

NOTE Connecting pin 4 and 5 together causes Up to be 8 to 9V.

7.10.10.8 X23 Sine Encoder Feedback

This feedback device does not deliver absolute information for commutation and works with wake&shake commutation (WorkBench Online Help). All signals are connected to X23 / X41 and evaluated there.

If cable lengths of more than 25m are planned, please consult customer support.

Type	FBx.INDENTIFIED	Up	Frequency Limit
SinCos 1 V p-p (Wake & Shake)	21	5.1 V \pm 3.5%	1 MHz, 250 kHz for encoders that require termination resistors

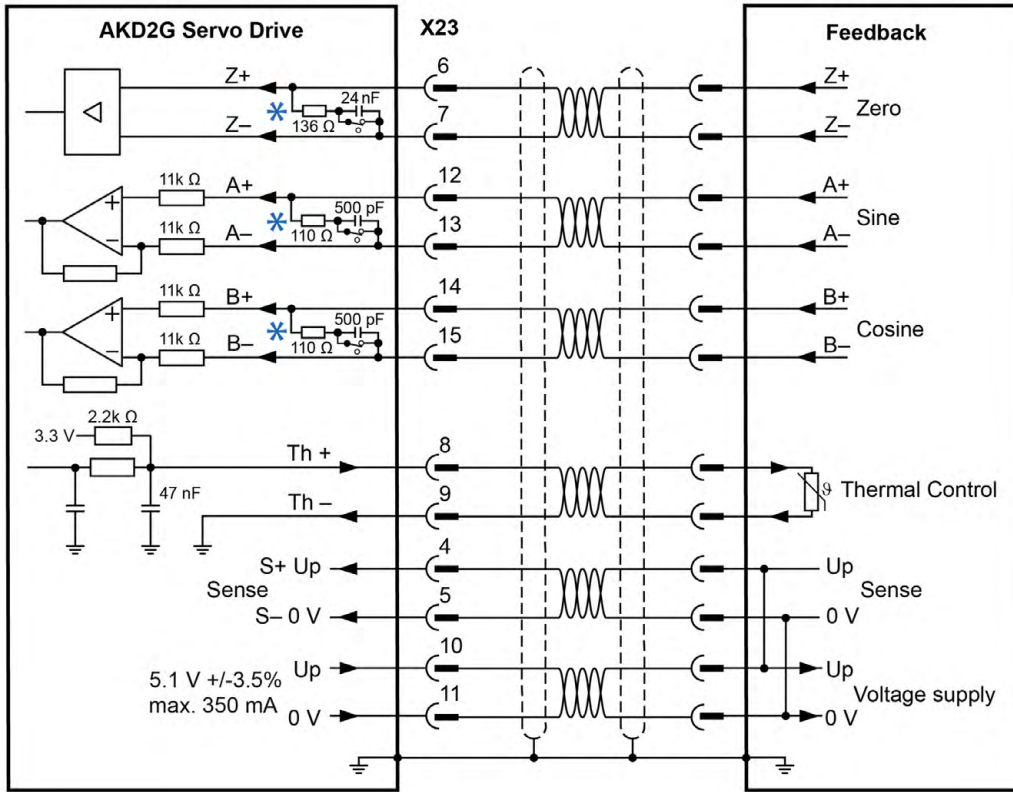

* DC terminated by default - DC switch closed.

7.10.10.9 X23 Sine Encoder with Hall Feedback

This feedback device delivers absolute information for commutation and can be used as a complete feedback system. All signals are connected to X23 / X41 and evaluated there.

If cable lengths of more than 25m are planned, please consult customer support.

Type	FBx.INDENTIFIED	Up	Frequency Limit
SinCos 1 V p-p with Hall	20	5.1V ± 3.5%	1 MHz, 250 kHz for encoders that require termination resistors

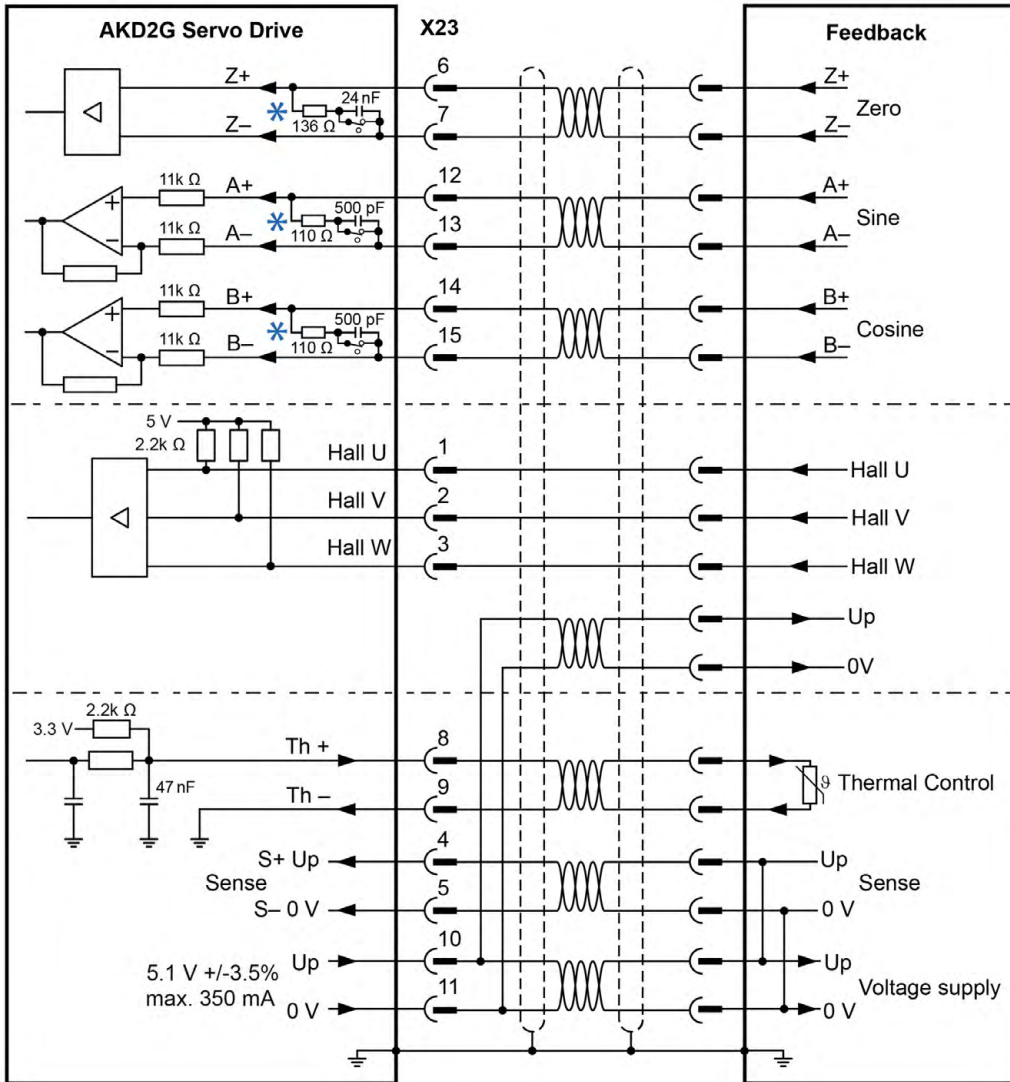

* DC terminated by default - DC switch closed.

7.10.10.10 X23 Incremental Encoder Feedback

This feedback device does not deliver absolute information for commutation and works with Wake and Shake commutation (see WorkBench Online Help). All signals are connected using a pre-assembled comcoder connection cable. The thermal control in the motor is connected via the encoder cable and evaluated in the drive.

If cable lengths of more than 25m are planned, please consult customer support.

Type	FBx.INDENTIFIED	Up	Frequency Limit
Incremental Encoder (Wake and Shake)	11	5.1V ± 3.5%	2.5 MHz

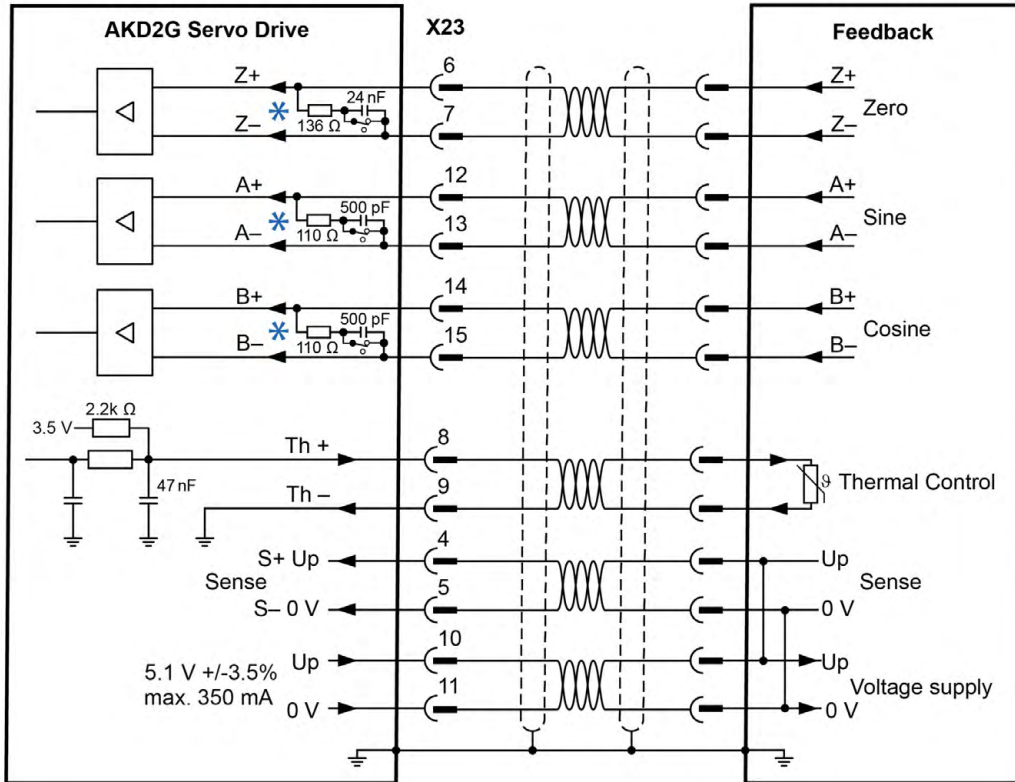

* DC terminated by default - DC switch closed.

7.10.10.11 X23 Incremental Encoder with Hall Feedback

This feedback device delivers absolute information for commutation and can be used as a complete feedback system. All signals are connected using a pre-assembled comcoder connection cable. The thermal control in the motor is connected via the encoder cable and evaluated in the drive.

If cable lengths of more than 25m are planned, please consult customer support.

Type	FBx.INDENTIFIED	Up	Frequency Limit
Incremental Encoder with Hall Switches (Comcoder)	10	5.1V ± 3.5%	2.5 MHz

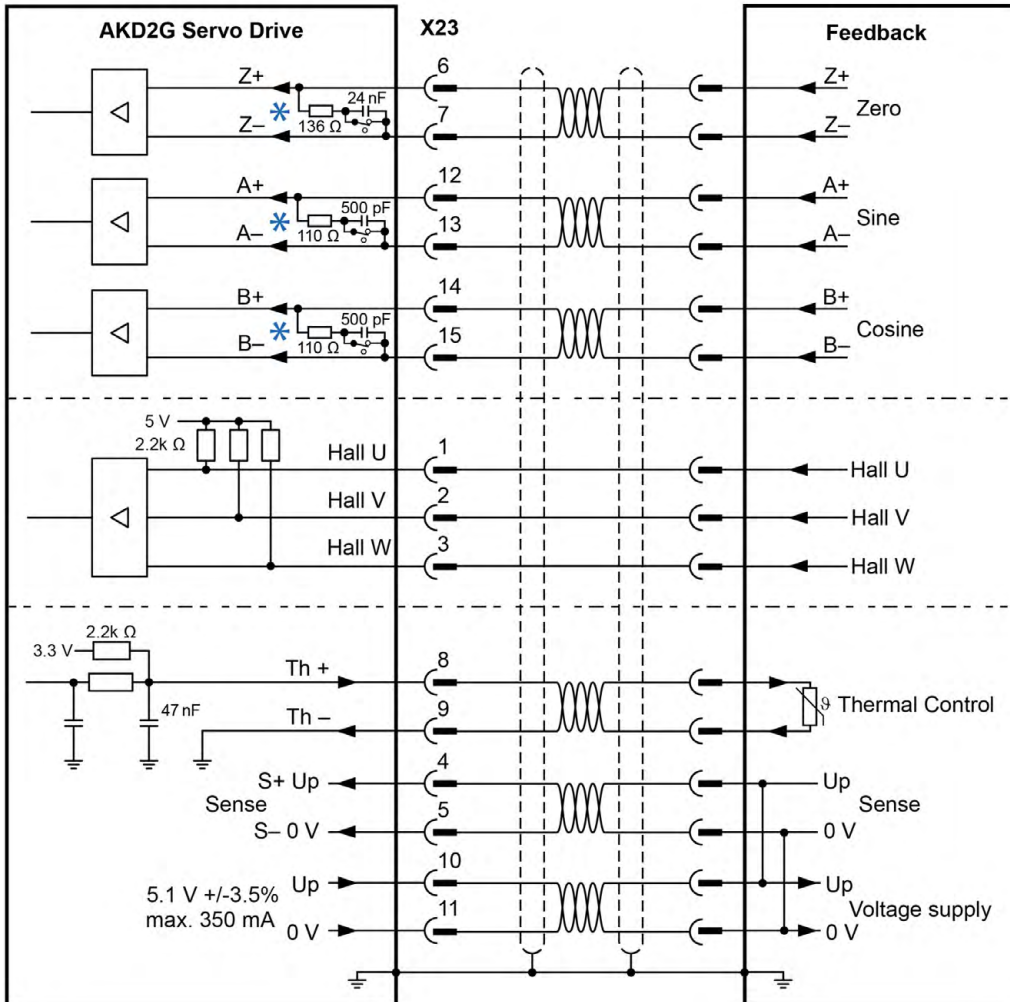

* DC terminated by default - DC switch closed.

7.10.10.12 X23 Hall Feedback

This feedback type only supports operating in Torque mode and Velocity mode.

If cable lengths of more than 25m are planned, please consult customer support.

Type	FBx.INDENTIFIED	Up	Frequency Limit
Hall Only	12	5.1V ± 3.5%	1 MHz

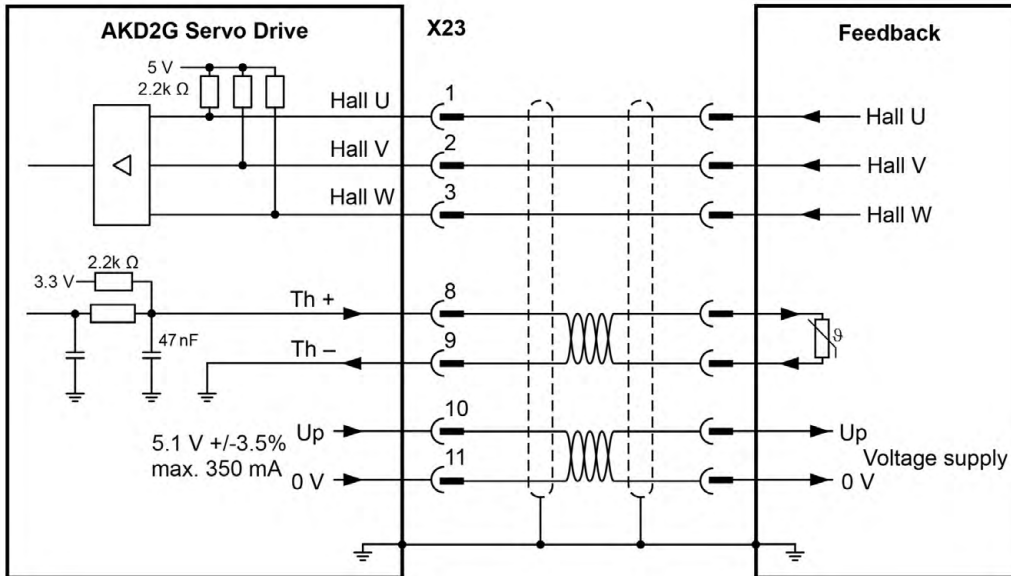

For more information concerning Hall feedback setting refer to WorkBench Online Help.

7.10.10.13 X23 SSI Feedback

Synchronous Serial Interface (SSI) is a standard industrial serial interface based on RS-422 standards.

If cable lengths of more than 25m are planned, please consult customer support.

Type	FBx.INDENTIFIED	Up	Frequency Limit
SSI (Synchronous Serial Interface)	36	5.1V ± 3.5%	1 MHz

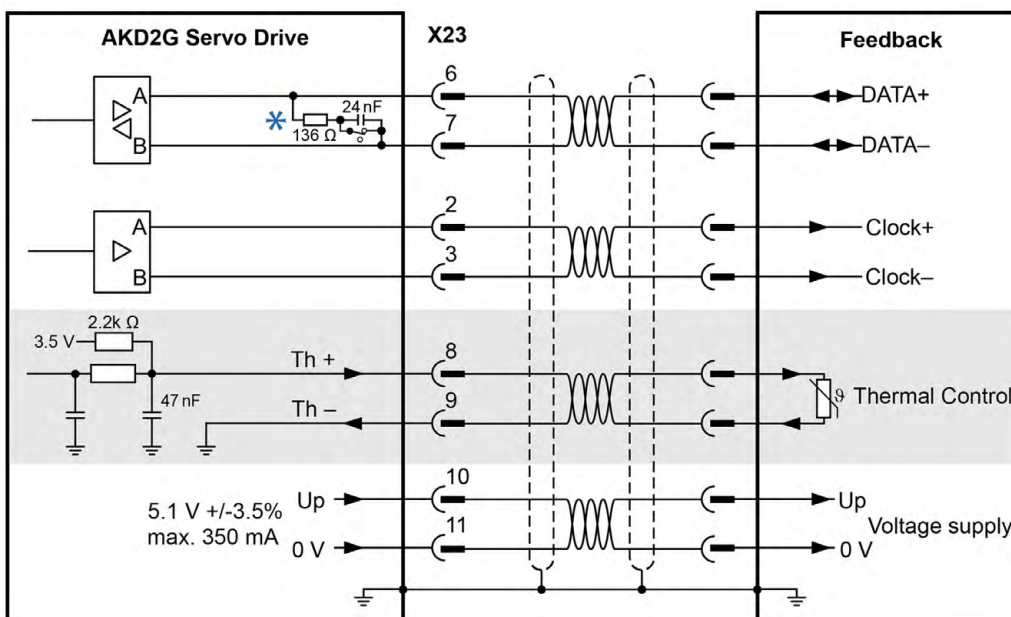

* DC terminated by default - DC switch closed.

Optional

7.10.10.14 X23 Step / Direction and CW / CCW Feedback

These feedback options are intended to be used by controllers to provide an Electronic Gearing source signal. If cable lengths of more than 25m are planned, please consult customer support.

Type	FBx.INDENTIFIED	Up	Frequency Limit
Step / Direction	13	5.1V ± 3.5%	1 MHz
CW / CCW	14	5.1V ± 3.5%	

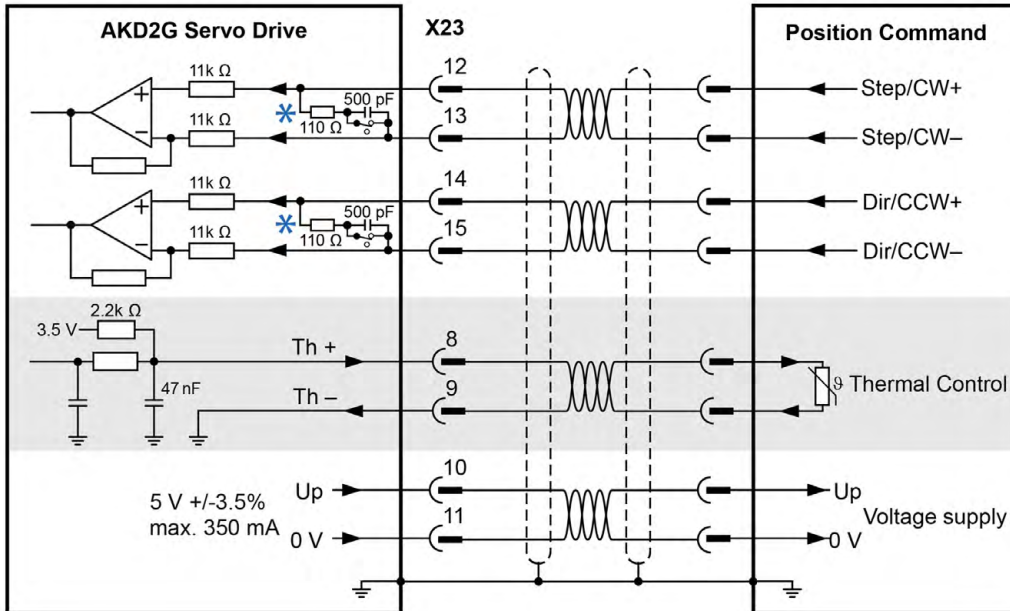

* DC terminated by default - DC switch closed.

Optional

7.10.11 Feedback Connector X41 (SFA, accessory)

SFA (Smart Feedback Adapter) converts conventional feedback signals to a 2-wire serial signal. SFA can be laid into the cable duct or may be mounted to a DIN rail using a standard DIN rail clip.

SFA provides a 15 pole HD Sub-D female connector X41 to the system for connection of a Kollmorgen motor feedback cable (see *Kollmorgen 2G Cable Guide*). Dimensions (LxWxD): 88.6 x 55.6 x 21.2 (28.6 with rail clip). Order codes see regional Accessories Manual.

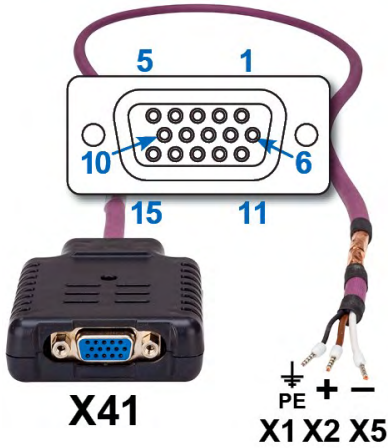

- Sub-D high density 15 pin, female
- 1 m shielded cable with 3 flying leads for connection to X1 or X2 or X5
- The cable shield is connected by using shield wire to X5/1 or with cable ties to the X1/X2 shield plates.
- Connected feedback must be set in WorkBench.
- Only use Kollmorgen feedback cables. The cable shield must be grounded on the end near the SFA.
- SFA models with a metal DIN clip must be mounted inside a cabinet.
- Input for Electronic Gearing, (→ # 151)
- Output for encoder emulation (EXX3/EXX4), (→ # 151) - Only available on "-EXX" (Encoder) models
- Master-Slave (→ # 153)

Connect the flying leads of the SFA cable to X1 (FB1, EXX3) or X2 (FB2, EXX4) or X5 (FB2, EXX4):

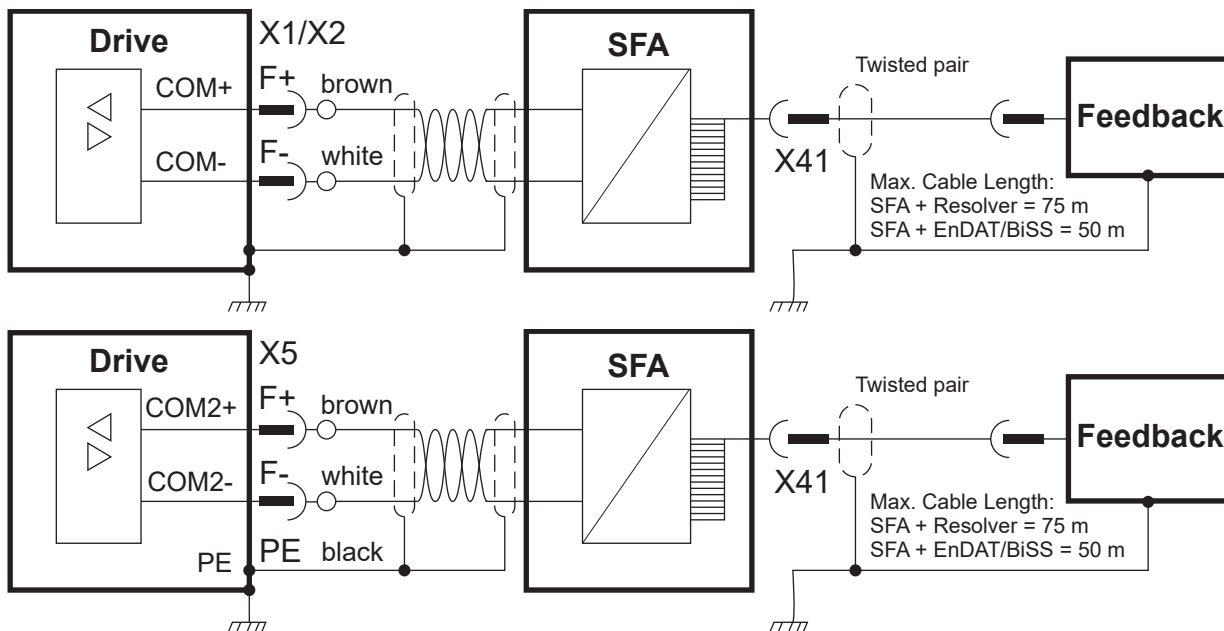

7.10.11.1 X41 Connector Pinout Summary

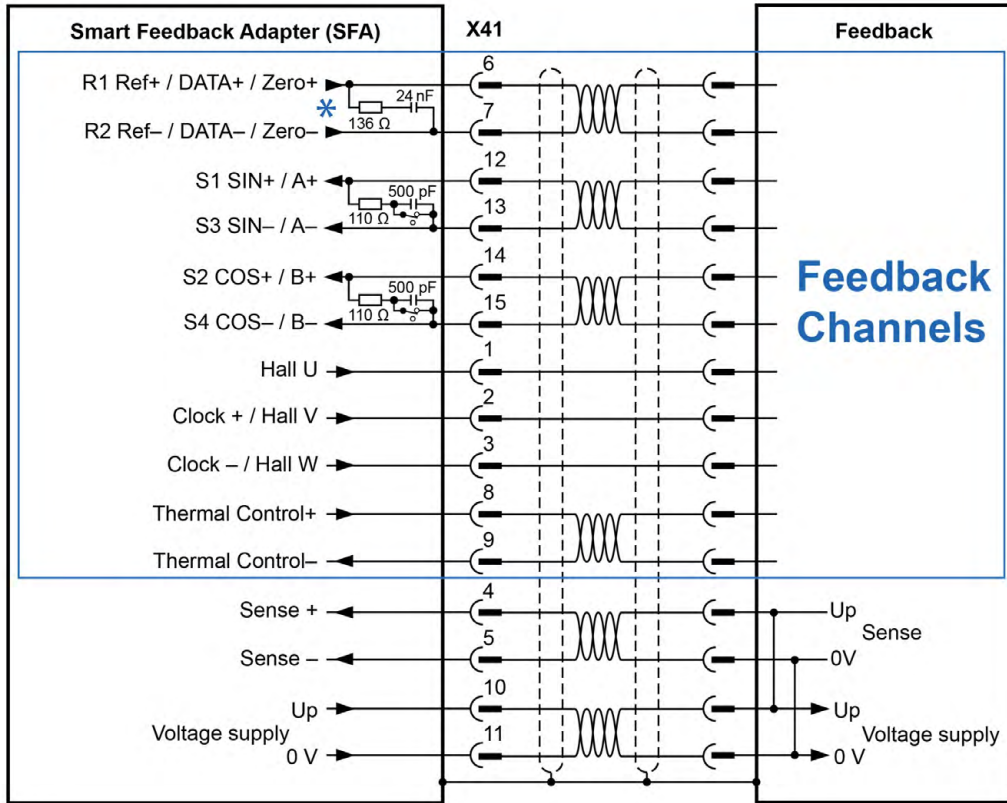

* The SFA does not include a DC termination switch across pins 6 and 7.

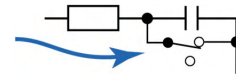

Operating Voltage: 7 V to 12 V, max. Load Current: 350 mA
 Max. A/B signal input frequency: 3 MHz

Pin	SFD	Resolver	BiSS B	BiSS C	EnDat 2.1	EnDat 2.2*	HIPERFACE®	Sine/ Cos	Sine/ Cos +Hall	Incr. Enc.	Incr. Enc. +Hall	Hall	SSI
1	-	-	-	-	-	-	-	-	Hall U	-	Hall U	Hall U	-
2	-	-	CLK+	CLK+	CLK+	CLK+	-	-	Hall V	-	Hall V	Hall V	-
3	-	-	CLK-	CLK-	CLK-	CLK-	-	-	Hall W	-	Hall W	Hall W	-
4	SEN+	-	SEN+	SEN+	SEN+	SEN+	I	SEN+	SEN+	SEN+	SEN+	-	-
5	SEN-	-	SEN-	SEN-	SEN-	SEN-		SEN-	SEN-	SEN-	SEN-	SEN-	-
6	COM+	R1 Ref+	DAT+	DAT+	DAT+	DAT+	DAT+	Zero+	Zero+	Zero+	Zero+	-	D+
7	COM-	R2 Ref-	DAT-	DAT-	DAT-	DAT-	DAT-	Zero-	Zero-	Zero-	Zero-	-	D-
8	Th+	Th+	Th+	Th+	Th+	Th+	Th+	Th+	Th+	Th+	Th+	-	Th+
9	Th-	Th-	Th-	Th-	Th-	Th-	Th-	Th-	Th-	Th-	Th-	-	Th-
10	+5 V	-	+5 V	+5 V	+5 V	+5 V	8-9 V	+5 V	+5 V	+5 V	+5 V	+5 V	+5 V
11	0 V	-	0 V	0 V	0 V	0 V	0 V	0 V	0 V	0 V	0 V	0 V	0 V
12	-	S1 SIN+	A+	-	A+	-	SIN+	A+	A+	A+	A+	-	-
13	-	S3 SIN-	A-	-	A-	-	SIN-	A-	A-	A-	A-	-	-
14	-	S2 COS+	B+	-	B+	-	COS+	B+	B+	B+	B+	-	-
15	-	S4 COS-	B-	-	B-	-	COS-	B-	B-	B-	B-	-	-

CL = CLOCK, D = DATA, S = SENSE, Th = Thermal control, Z = Zero

(1) : Resolver with AKD2G-CON-SFA-R00 only, all other feedback devices with AKD2G-CON-SFA-E00 only

■ = DC Terminated, can be overridden with [DIO#.TERM](#)

■ = Optional

■ = Information digitally communicated on COM+/- channel.

7.10.12 X41 Feedback Wiring Pinout Diagrams

7.10.12.1 X41 SFD Feedback

The diagram below shows the connection of the four-wire Kollmorgen SFD feedback system.

NOTE

When SFD cable total resistance for 5V out (Up) and 5V return (0V) is less than 3.3 Ohm, then remote sensing is not needed. For a typical cable this means remote sensing is not needed up to 25m.

Kollmorgen cables are rated up to 50m with no remote sensing.

Type	FBx.INDENTIFIED	Up	Description
Smart Feedback Device (SFD)	141	5.1 V \pm 3.5%	Accuracy: 14 bit (0.022°), resolution: 24 bit (2x10E-5°)

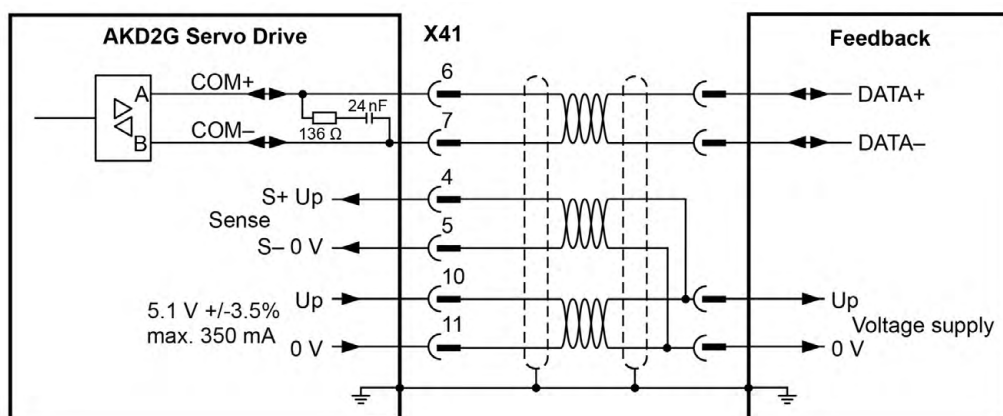

7.10.12.2 X41 Resolver Feedback

The diagram below shows the connection of a resolver (2 to 36-poles) as a feedback system. The thermal control in the motor is connected via the Resolver cable and evaluated in the drive. If no thermal control is in the motor, the cable must short pins 8 and 9.

If cable lengths of more than 100m are planned, please contact customer support.

Type	FBx.INDENTIFIED	Description
Resolver	140	Accuracy: 14 bit (0.022°), resolution: 16 bit (0.006°), frequency (fixed): 6875 Hz

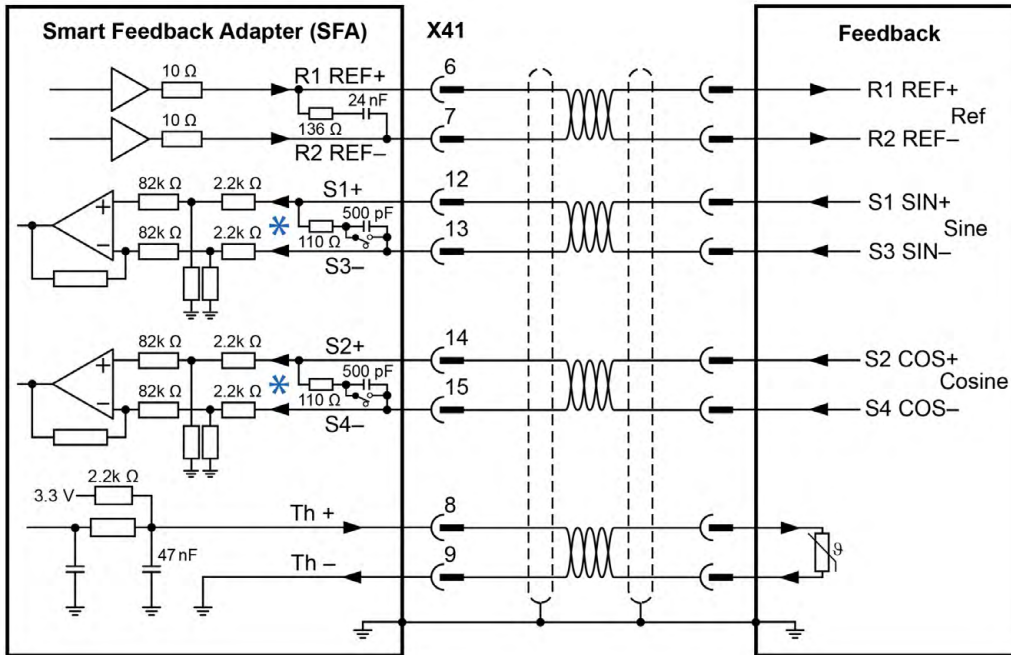

* Resolver Sine/Cosine channels must be high impedance - DC termination switch open.

7.10.12.3 X41 BiSS (Mode B) Analog Feedback

The diagram below shows the wiring of a single-turn or multi-turn encoder with BiSS Mode B interface as a feedback system. The thermal control in the motor is connected via the encoder cable and evaluated in the drive.

If cable lengths of more than 50m are planned, please consult customer support.

Type	FBx.INDENTIFIED	Up	Frequency Limit
BiSS (Mode B) Analog	132	5.1V ± 3.5%	1 MHz, 250 kHz for encoders that require termination resistors

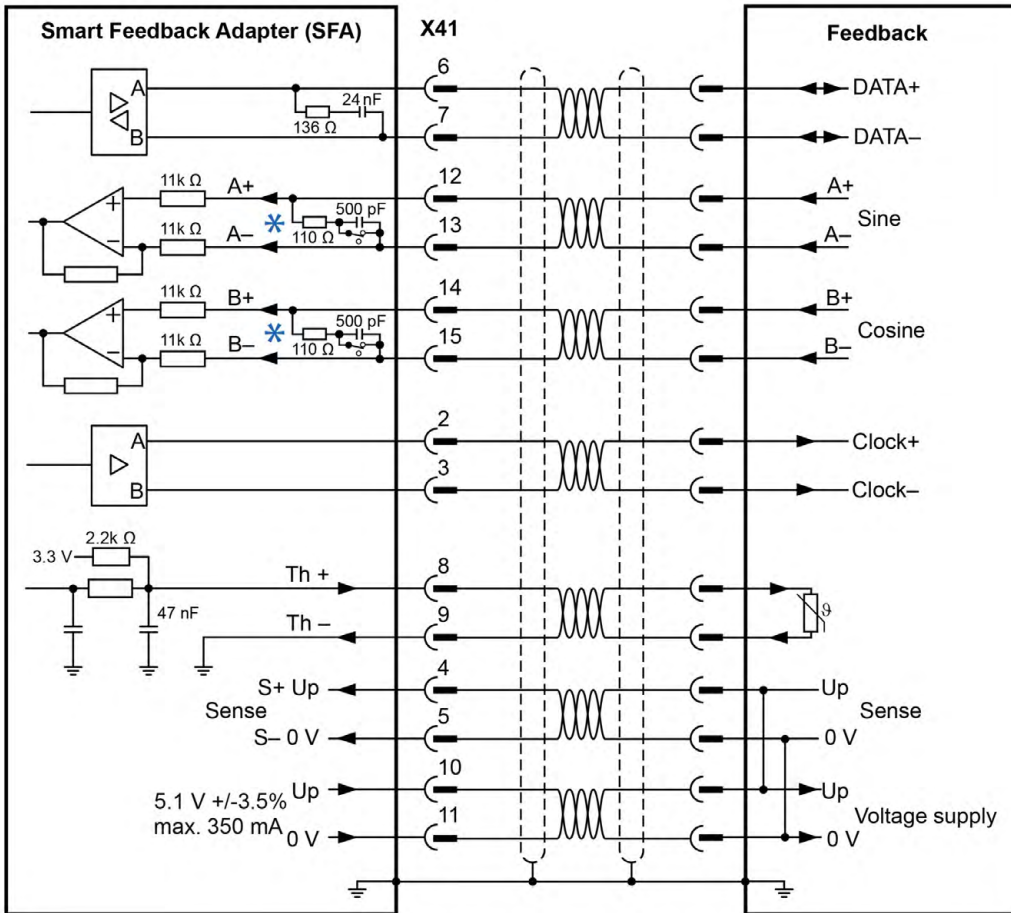

* DC terminated by default - DC switch closed.

7.10.12.4 X41 BiSS (Mode C) Digital Feedback

The diagram below shows the wiring of a single-turn or multi-turn encoder with BiSS Mode C interface from Renishaw (specifically model Resolute RA26B) as a feedback system.

If cable lengths of more than 25m are planned, please consult customer support.

Type	FBx.INDENTIFIED	Up	Frequency Limit
BiSS (Mode C) Digital	134	5.1V ± 3.5%	1 MHz

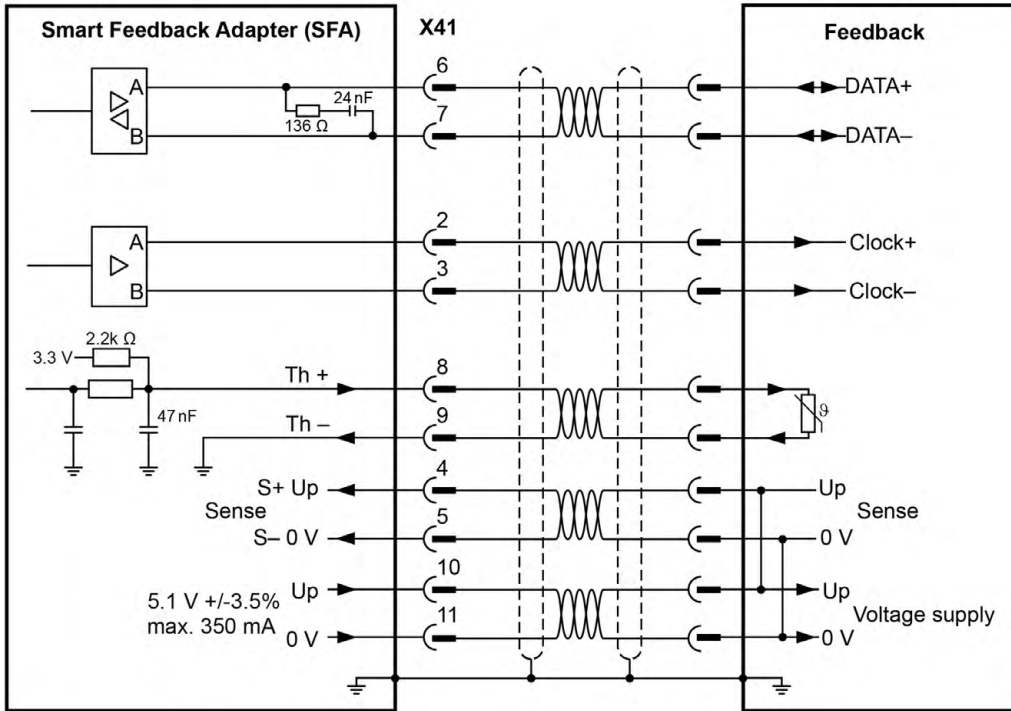

7.10.12.5 X41 EnDAT 2.1 Feedback (with 1 V p-p analog signals)

The diagram below shows the wiring of a single-turn or multi-turn sine-cosine encoder with EnDat 2.1 interface as a feedback system. Preferred types are the ECN1313 and EQN1325 encoders. The thermal control in the motor is connected via the encoder cable and evaluated in the drive. All signals are connected using our pre-assembled encoder connection cable.

If cable lengths of more than 50m are planned, please consult customer support.

Type	FBx.INDENTIFIED	Frequency Limit
EnDAT 2.1	130	1 MHz, 250 kHz for encoders that require termination resistors

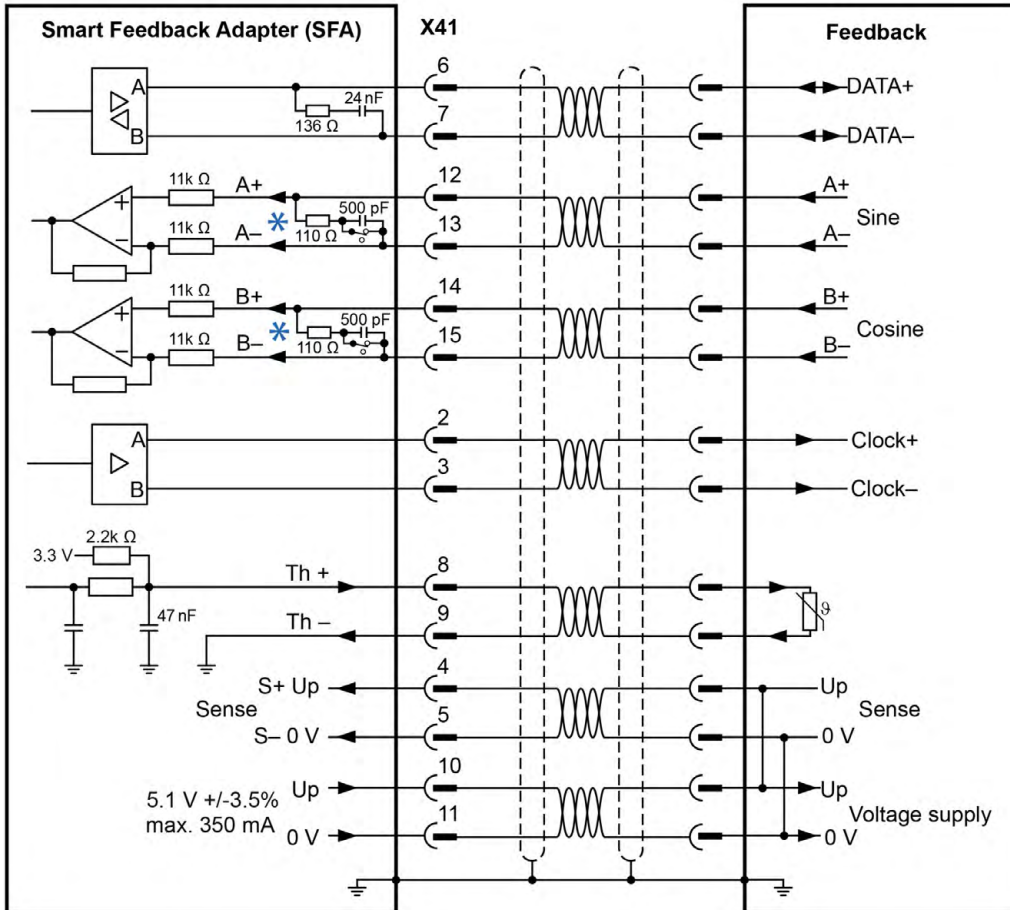

* DC terminated by default - DC switch closed.

7.10.12.6 X41 EnDAT 2.2 Digital Feedback

Single-turn or multi-turn encoders with EnDat 2.2 interface can be connected either to X23 or X41 as a primary motor feedback system.

All signals are connected using our pre-assembled encoder connection cable.

If cable lengths of more than 50m are planned, please consult customer support.

Type	FBx.INDENTIFIED	Frequency Limit
EnDAT 2.2	131	2.5 MHz

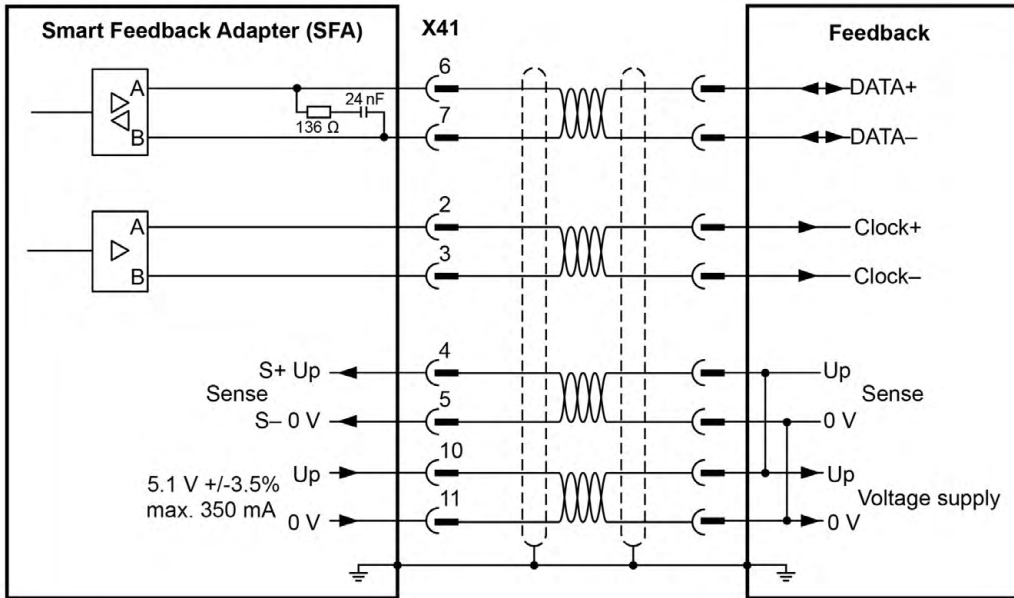

Select the analog I/O functionality in the related WorkBench screen on the drive.
Warning n256 is issued if the set limit is exceeded.

NOTE

For use as primary motor feedback, set parameters DRV.EMUEMODE, PL.FBSOURCE, IL.FBSOURCE, VL.FBSOURCE.

7.10.12.7 X41 HIPERFACE Feedback

The diagram below shows the wiring of a single-turn or multi-turn sine-cosine encoder with Hiperface interface as a feedback system.

The thermal control in the motor is connected via the encoder cable and evaluated in the drive. All signals are connected using our pre-assembled encoder connection cable.

If cable lengths of more than 50m are planned, please consult customer support.

Type	FBx.INDENTIFIED	Frequency Limit
HIPERFACE	133	1 MHz, 250 kHz for encoders that require termination resistors

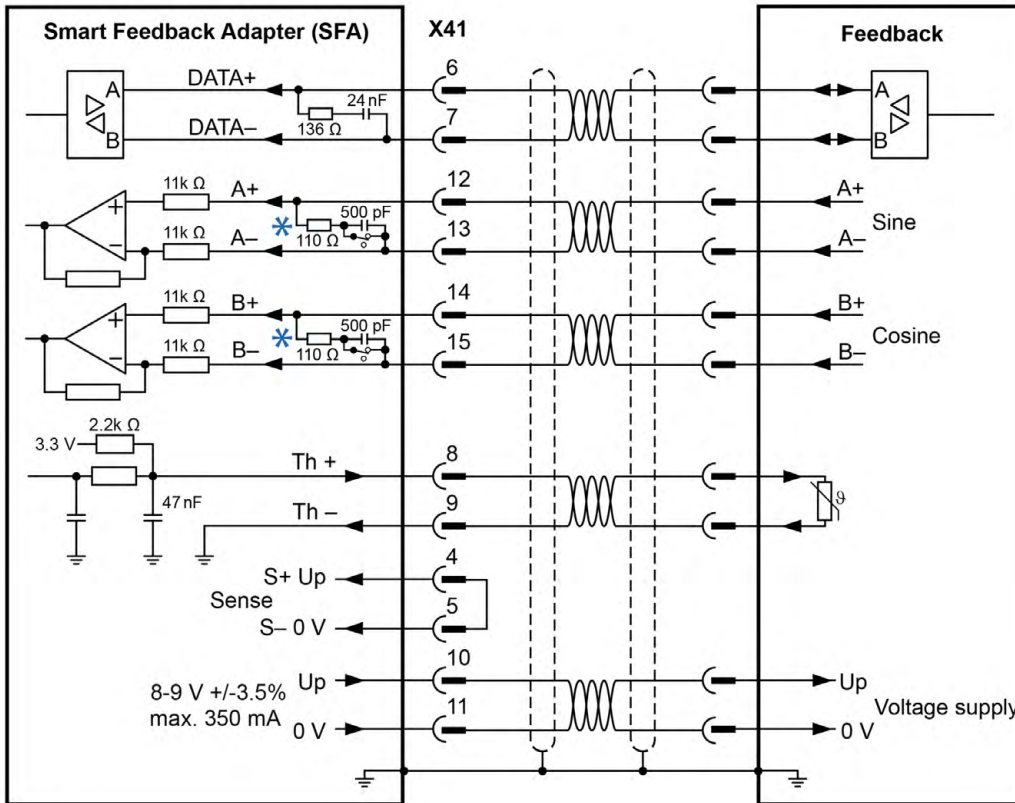

* DC terminated by default - DC switch closed.

NOTE

Connecting pin 4 and 5 together causes Up to be 8 to 9 V.

7.10.12.8 X41 Sine Encoder Feedback

This feedback device does not deliver absolute information for commutation and works with Wake&Shake commutation (WorkBench Online Help). All signals are connected to X23 / X41 and evaluated there.

If cable lengths of more than 25m are planned, please consult customer support.

Type	FBx.INDENTIFIED	Up	Frequency Limit
SinCos 1 V p-p (Wake & Shake)	121	5.1V ± 3.5%	1 MHz, 250 kHz for encoders that require termination resistors

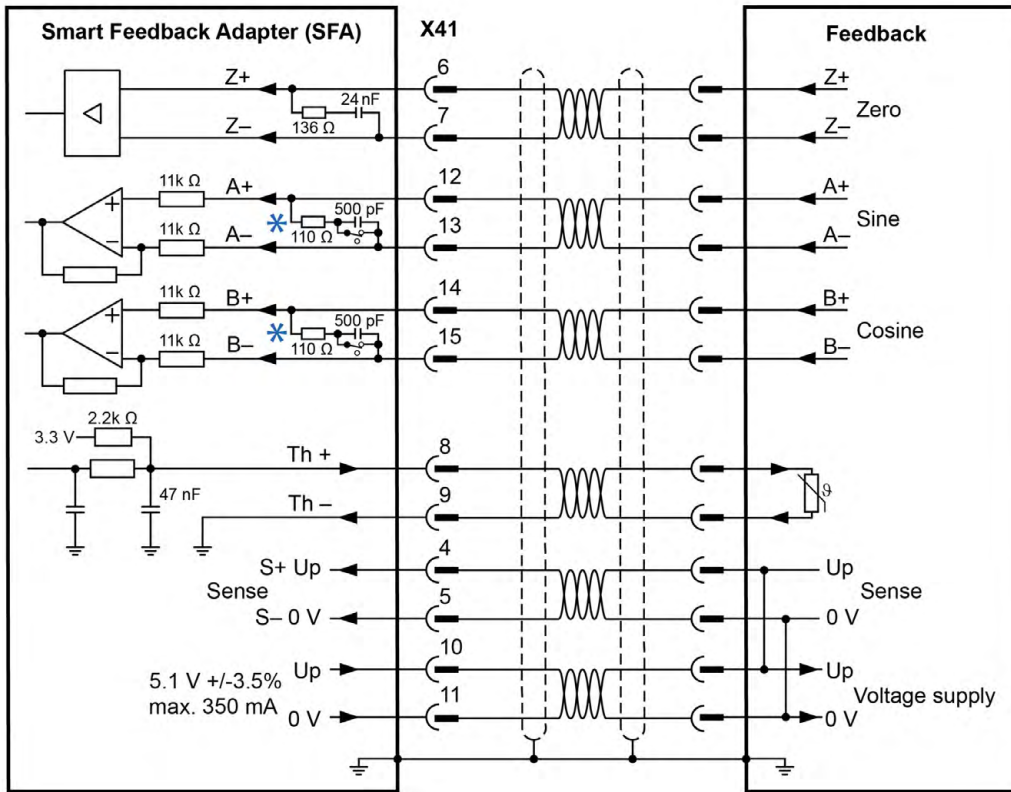

* DC terminated by default - DC switch closed.

7.10.12.9 X41 Sine Encoder with Hall Feedback

This feedback device delivers absolute information for commutation and can be used as a complete feedback system. All signals are connected to X23 / X41 and evaluated there.

If cable lengths of more than 25m are planned, please consult customer support.

Type	FBx.INDENTIFIED	Up	Frequency Limit
SinCos 1 V p-p with Hall	120	5.1V ± 3.5%	1 MHz, 250 kHz for encoders that require termination resistors

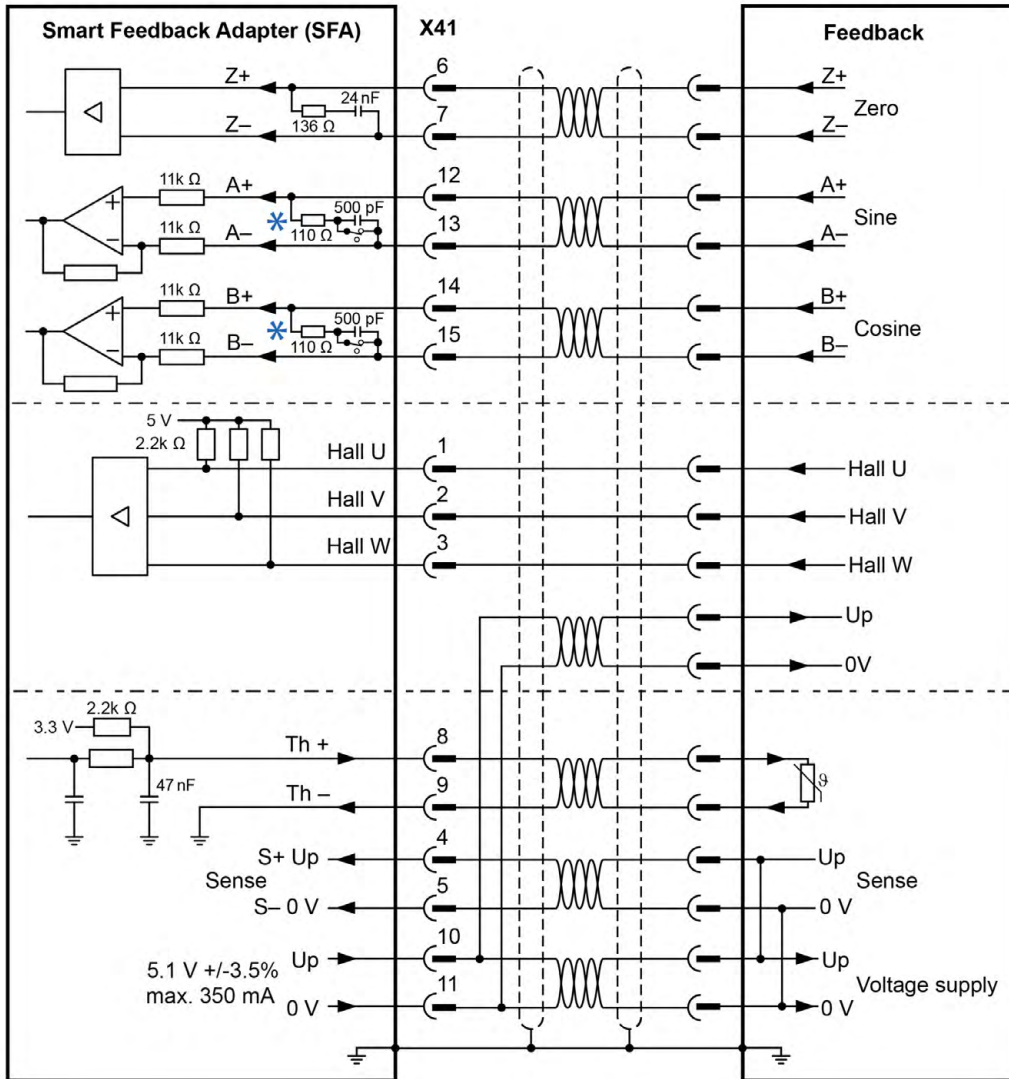

* DC terminated by default - DC switch closed.

7.10.12.10 X41 Incremental Encoder Feedback

This feedback device does not deliver absolute information for commutation and works with Wake&Shake commutation (see WorkBench Online Help). All signals are connected using a pre-assembled comcoder connection cable. The thermal control in the motor is connected via the encoder cable and evaluated in the drive.

If cable lengths of more than 25m are planned, please consult customer support.

Type	FBx.INDENTIFIED	Up	Frequency Limit
Incremental Encoder (Wake and Shake)	111	5.1V ± 3.5%	2.5 MHz

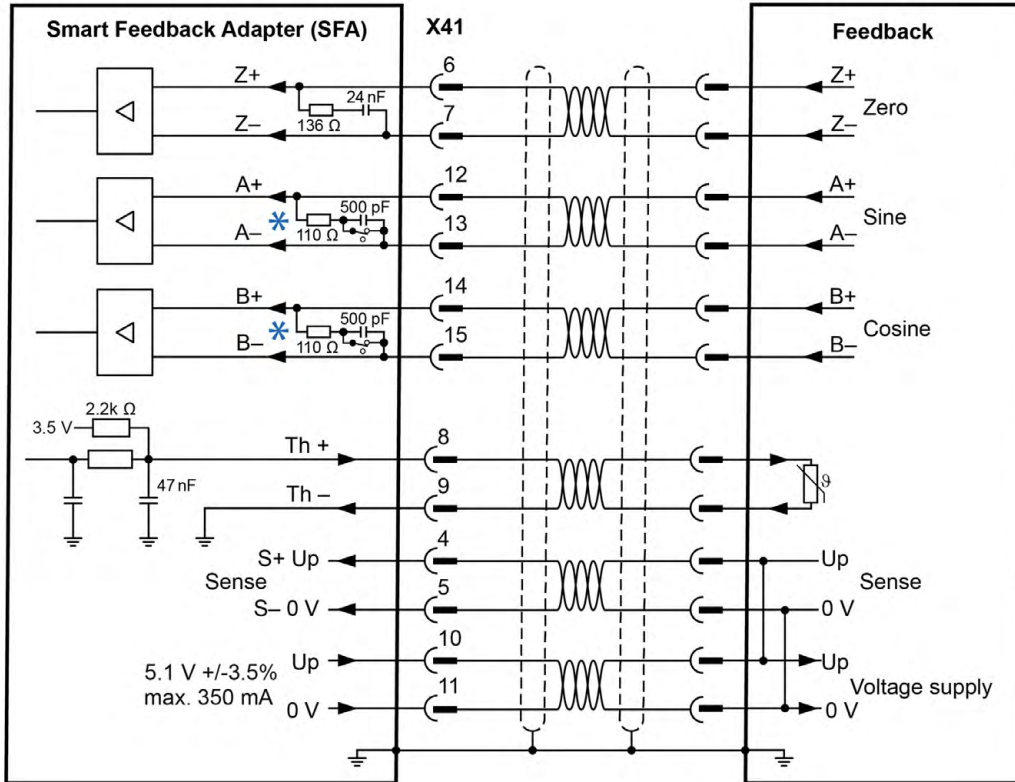

* DC terminated by default - DC switch closed.

7.10.12.11 X41 Incremental Encoder with Hall Feedback

This feedback device delivers absolute information for commutation and can be used as a complete feedback system. All signals are connected using a pre-assembled comcoder connection cable. The thermal control in the motor is connected via the encoder cable and evaluated in the drive.

If cable lengths of more than 25m are planned, please consult customer support.

Type	FBx.INDENTIFIED	Up	Frequency Limit
Incremental Encoder with Hall Switches (Comcoder)	110	5.1V ± 3.5%	2.5 MHz

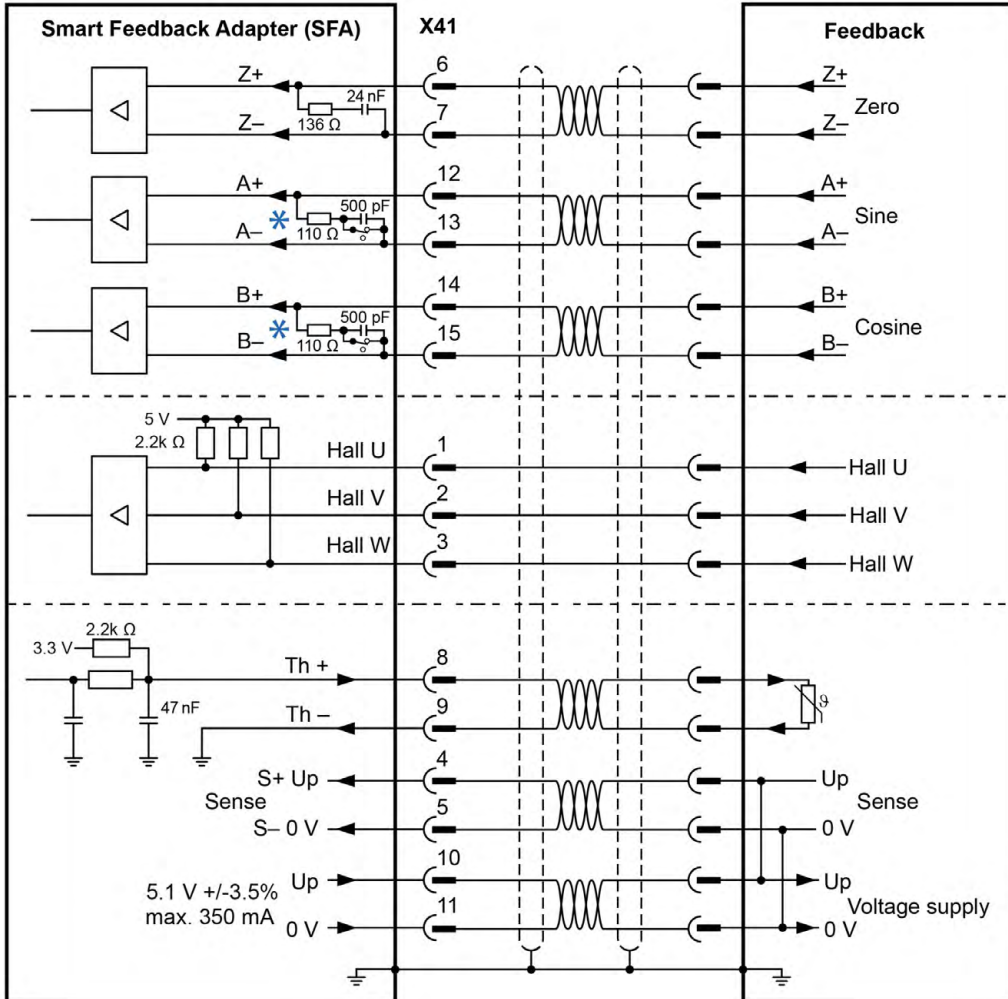

* DC terminated by default - DC switch closed.

7.10.12.12 X41 Hall Feedback

This feedback type only supports operating in Torque mode and Velocity mode.

If cable lengths of more than 25m are planned, please consult customer support.

Type	FBx.INDENTIFIED	Up	Frequency Limit
Hall Only	112	5.1V ± 3.5%	1 MHz

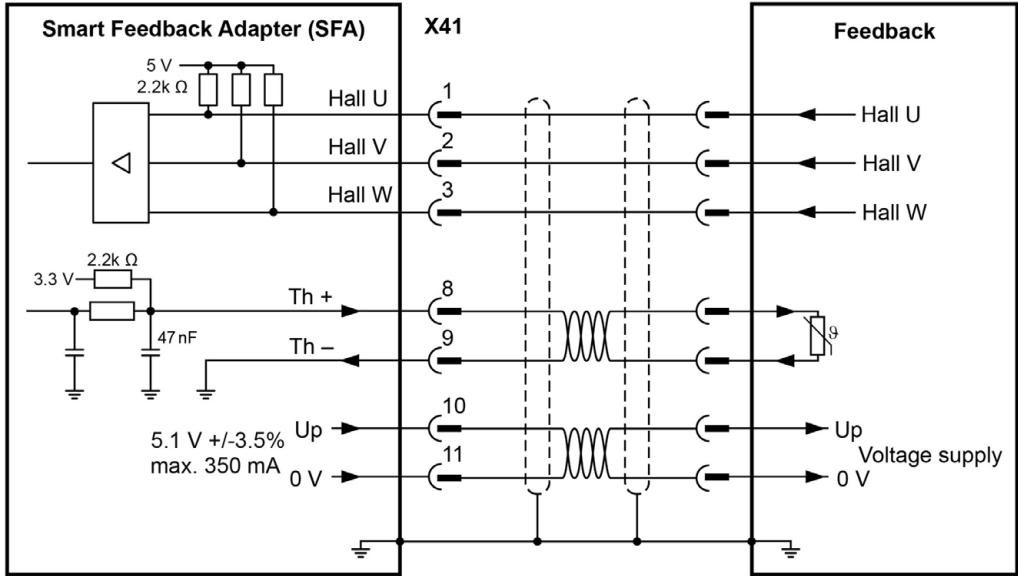

For more information concerning Hall feedback setting refer to WorkBench Online Help.

7.10.12.13 X41 SSI Feedback

Synchronous Serial Interface (SSI) is a standard industrial serial interface based on RS-422 standards.

If cable lengths of more than 25m are planned, please consult customer support.

Type	FBx.INDENTIFIED	Up	Frequency Limit
SSI (Synchronous Serial Interface)	136	5.1V ± 3.5%	1 MHz

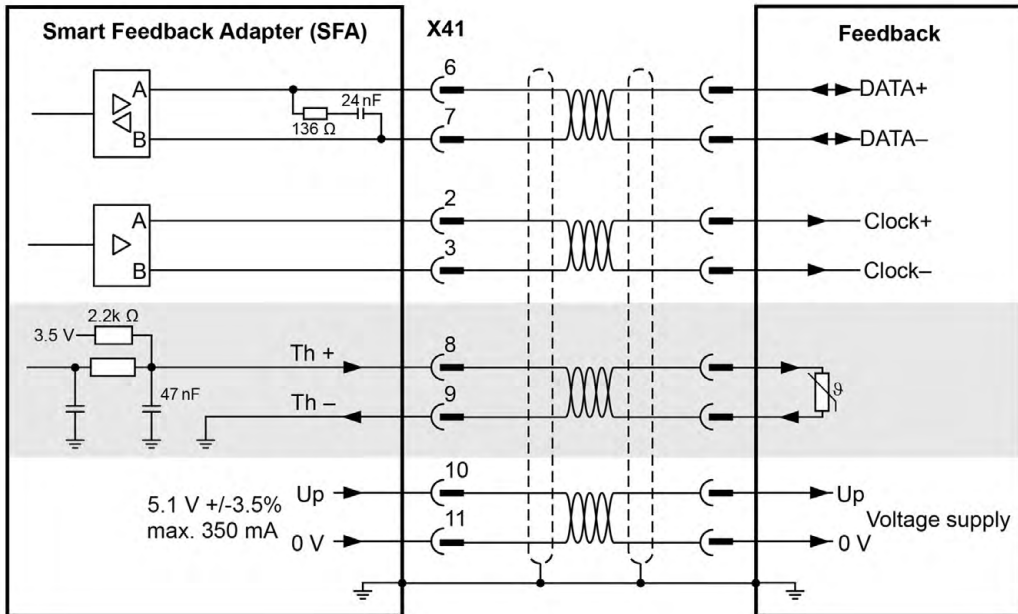

Optional

7.11 Gearing

7.11.1 Overview

Electronic Gearing, EEO, Master-Slave

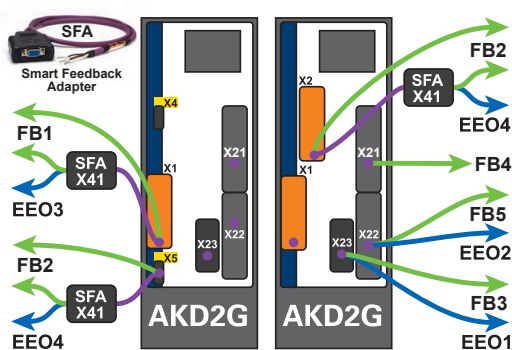

AKD2G offers up to 5 feedback channels, which may be used as the command source for electronic gearing or EEO (Emulated Encoder Output) or Master-Slave.

Feedback channel	EEO channel	Connector	Pinout and wiring example	Parameter to configure the sensor type
Feedback 1	N/A	X1	(→ # 118)	FB1.SELECT
	EEO3	X41 via X1	(→ # 137)	
Feedback 2		X2	(→ # 118)	FB2.SELECT
		X5	(→ # 119)	
	EEO4	X41 via X2 or X5	(→ # 137)	
Feedback 3	EEO1	X23	(→ # 122)	FB3.SELECT
Feedback 4	N/A	X21	(→ # 120)	FB4.SELECT
Feedback 5	EEO2	X22	(→ # 121)	FB5.SELECT

7.11.2 Input - Electronic Gearing

AKD2G offers up to 5 feedback channels. Any of these channels may be used as the gearing command source. The gearing source is selected for each axis using `AXIS#.GEAR.FBSOURCE`. Refer to the WorkBench Online Help [Electronic Gearing](#) for more information.

7.11.3 Output - Emulated Encoder Output (EEO)

The drive calculates the motor shaft position from the cyclic- absolute signals of the commutation feedback, generating incremental-encoder compatible pulses or CW/CCW signals or Pulse/Direction signals from this information.

The resolution and the index (zero) position can be set in WorkBench. The outputs are driven from an internal supply voltage. Refer to the WorkBench Online Help for more information.

NOTE

When using a multispeed resolver (more than 2 poles) as commutation feedback, the EEO will create only one zero pulse per each mechanical revolution of the motor. The zero pulse is dependent on the motor starting position!

NOTICE

EEO1-4 are NOT compatible with 24V signal level and will be damaged if connected to +24V!

Technical characteristics connector X22, EEO2

Pulse outputs on the connector X22 are 2 signals: track A and B with 90° phase difference (i. e. in quadrature, hence the alternative term “AquadB” output).

- RS-485, current 100 mA
- Max. number of connected slaves is determined by the loading characteristics of the slaves. 32 slaves can be driven if the input impedance of the bias network is 10kΩ and only one slave has a DC termination resistor.

- Max. signal (channel) output frequency: 3 MHz
- The pulses per revolution value is settable, pulse phase shift: $90^{\circ} \pm 20^{\circ}$

X22	Signals EEO2	Description
A17	AGND	Analog ground
A20	Track A+	EEO2 output, channel A positive
A21	Track A-	EEO2 output, channel A negative
B20	Track B+	EEO2 output, channel B positive
B21	Track B-	EEO2 output, channel B negative

Technical characteristics connector X23, EEO1

Pulse outputs on the SubD connector X23 are 3 signals: A, B and Index with 90° phase difference (i.e. AquadB) and a zero pulse.

- 5V TTL, current 60 mA
- Max. number of connected slaves is determined by the loading characteristics of the slaves, 32 slaves can be driven if the input impedance of the bias network is 10k Ω and only one slave has a DC termination resistor.
- Max. signal (channel) output frequency: 3 MHz
- The pulses per revolution value is settable, pulse phase shift: $90^{\circ} \pm 20^{\circ}$

X23	Signals EEO1	Description
6	Zero+	EEO1 output, index positive
7	Zero-	EEO1 output, index negative
11	0 V	EEO1 output, ground
12	Track A+	EEO1 output, channel A positive
13	Track A-	EEO1 output, channel A negative
14	Track B+	EEO1 output, channel B positive
15	Track B-	EEO1 output, channel B negative

Technical characteristics connector X41 (SFA), EEO3/EEO4

Pulse outputs on the SubD connector X41 are 3 signals: A, B and Index with 90° phase difference (i.e. "AquadB") and a zero pulse.

If SFA is connected to X1 the logical output is EEO3.

If SFA is connected to X2 or X5 the logical output is EEO4.

- 5V TTL, current 60 mA
- Max. number of connected slaves is determined by the loading characteristics of the slaves, 32 slaves can be driven if the input impedance of the bias network is 10k Ω and only one slave has a DC termination resistor.
- Max. signal (channel) output frequency: 3 MHz
- The pulses per revolution value is settable, pulse phase shift: $90^{\circ} \pm 20^{\circ}$

X41	Signals EEO3/EEO4	Description
6	Zero+	EEO3/EEO4 output, index positive
7	Zero-	EEO3/EEO4 output, index negative
11	0 V	EEO3/EEO4 output, ground
12	Track A+	EEO3/EEO4 output, channel A positive
13	Track A-	EEO3/EEO4 output, channel A negative
14	Track B+	EEO3/EEO4 output, channel B positive
15	Track B-	EEO3/EEO4 output, channel B negative

7.11.4 Master-Slave control

Several AKD2G can be connected as slave drives to another AKD2G which acts as a master. The slave drives use the master's encoder output signal (EEO, (→ # 151)) as command input and follow these commands (velocity and direction).

7.11.4.1 Examples

Master-Slave using feedback connector X22

The master is configured for EEO2 (→ # 151) on X22 for command output.

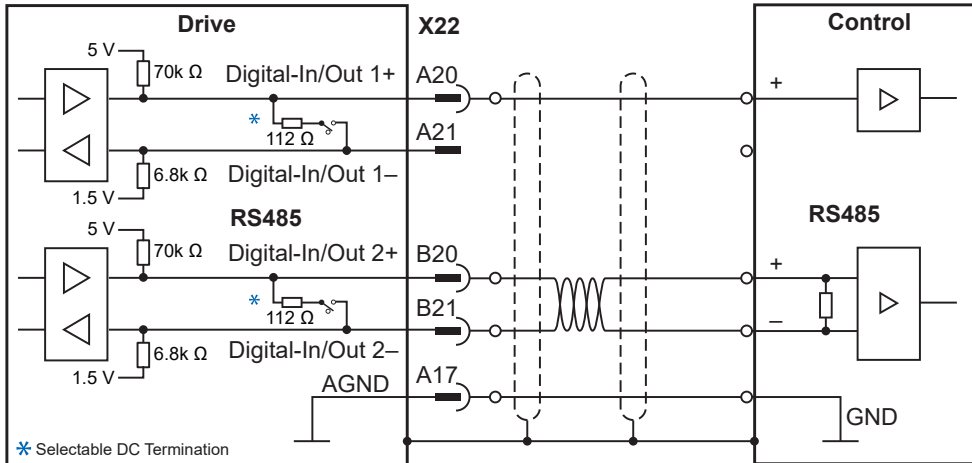

The slave is configured using Feedback 5 (FB5) on X22 for command input.

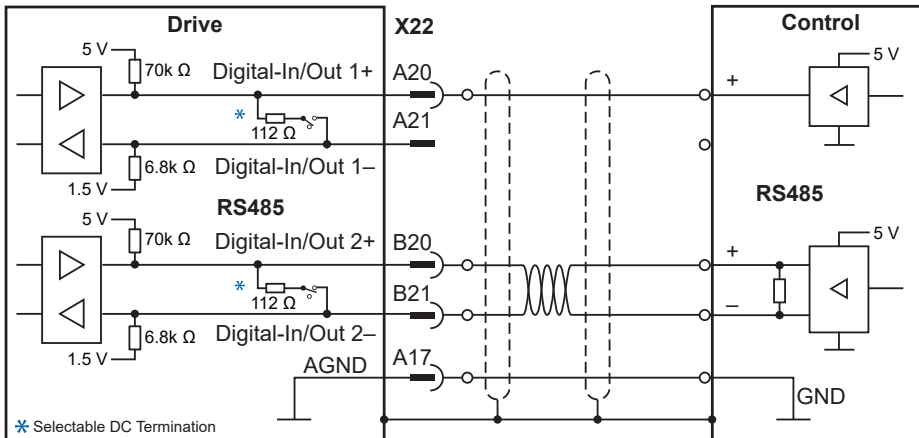

Master-Slave using optional feedback connector X23 or X41

The master is configured for EEO1 (→ # 152) on X23 or EEO3/EEO4 (→ # 151) with SFA) on X41, the slave uses Feedback 3 (FB3) on X23 (or X41 with SFA) for command input.

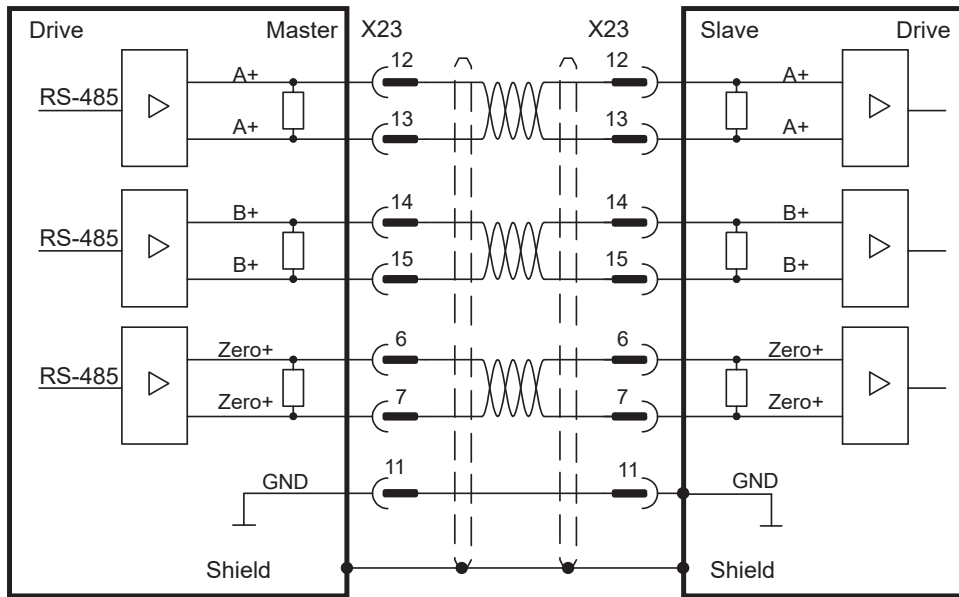

7.12 Ethernet Fieldbus Interface Connector X11/X12

The Ethernet fieldbus interface has two RJ45 connectors.

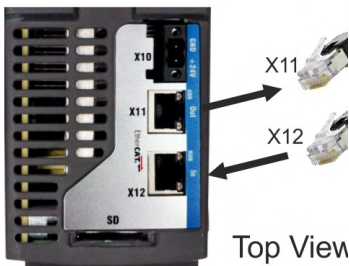

- RJ45 with built-in green/red dual-color LED
- EtherCAT®
- EtherNet/IP®
- PROFINET®

NOTICE

Do not connect the Service line for the PC with the set up software to the Ethernet fieldbus interface X11/X12 when using EtherCAT. The service Ethernet cable must be connected to X20. Ethernet fieldbus interface X11/X12 pinout depends on the protocol used. Refer to the matching fieldbus communication manual.

7.12.1 EtherCAT® and Safety over EtherCAT®

AKD2G drives (connectivity option E) can be connected as slaves to the EtherCAT® network (CoE) by using RJ45 connectors X11 (out port) and X12 (in port). The communication status is indicated by the built-in connector LEDs.

	Connector	Name	Function
	X11 "Out"	"ERR"	Returns potentials communication failures: Off = No Error Blinking = Invalid configuration Single Flash = Local error Double Flash = Process data watchdog
	X11 "Out"	Link/ Activity	On/Blinking: Physical link/Data Traffic on. Static off: No link.
	X12 "In"	"RUN"	Returns the device state: Off = INIT Blinking = PRE-OPERATIONAL Single Flash = SAFE-OPERATIONAL On = OPERATIONAL Flickering = Initialization or BOOTSTRAP
	X12 "In"	Link/ Activity	On/Blinking: Physical link/Data Traffic on. Static off: No link.

Bus topology example (EtherCAT®)

We suggest to use Kollmorgen ENCP cables. For more possible system solutions refer to the WorkBench Online Help.

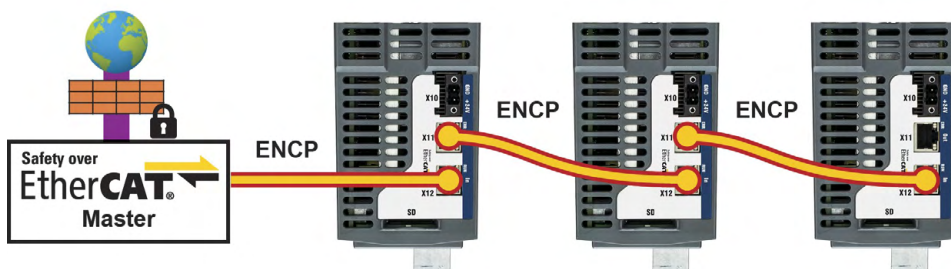

Communication profile

For EtherCAT® communication profile description refer to the manual "AKD2G EtherCAT® Communication". Notes to FSoE also see (→ # 213).

7.12.2 PROFINET

AKD2G with connectivity option **P** can be connected as slaves to a PROFINET network by using RJ45 connectors X11 (Port 2) and X12 (Port 1). PROFINET RT or IRT protocols can be used.



AKD2G with connectivity option **P** (PROFINET) has successfully passed the certification tests of "PROFIBUS Nutzerorganisation e.V."

Scope of the tests:

- PNIO Version: V2.35
- Conformance Class: C
- Optional Features: Legacy, MRP
- Application Class: Isochronous
- Netload Class: III

The certificate ([Z12974](#)) can be downloaded from the Kollmorgen website.

Address

The field bus address must either be set automatically or by using the memory card.

LEDs

The communication status is indicated by the built-in connector LEDs.

	Connector	Name	Function
	X11 Port 2	BF	ON = No Configuration, low speed, no link OFF = No Error Flashing 2Hz = No data exchange
	X11 Port 2	Link/ Activity	ON = Connection to the EtherNet OFF = No connection to the EtherNet Flashing = Sends/receives EtherNet frames
	X12 Port 1	SF	ON = Watchdog timeout; channel / generic / extended diagnosis present; system error OFF = No Error Flashing 2Hz = DCP signal service is initiated via the bus
	X12 Port 1	Link/ Activity	ON = Connection to the EtherNet OFF = No connection to the EtherNet Flashing = Sends/receives EtherNet frames

Bus topology example (PROFINET)

Kollmorgen suggest to use ENCP cables. For more possible system solutions refer to the WorkBench Online Help.

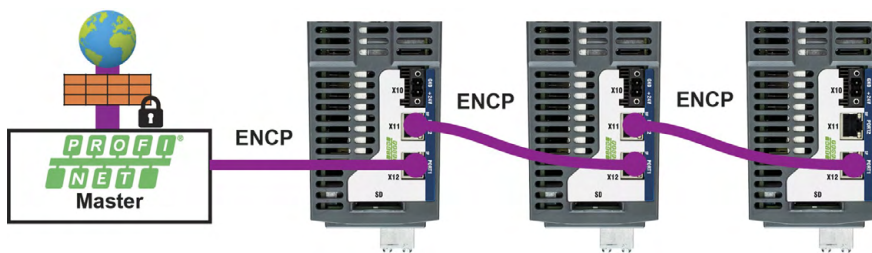

Communication profile

For PROFINET communication profile description refer to the manual "AKD2G PROFINET Communication".

7.12.3 EtherNet/IP

AKD2G with connectivity option I can be connected as slaves to a EtherNet/IP network by using RJ45 connectors X11 (Port 2) and X12 (Port 1). The communication status is indicated by the built-in connector LEDs.

Connector	Name	LED Indicator	Status	Function
	Network Status (NS)		On	Connection
			Flashing	No Connection
			Off	No power, No IP Address
			On	Duplicate IP Address
			Flashing	Connection Time-Out
			Flashing	Self-Test
	Link/Activity		On	Ethernet Connection
			Off	No Ethernet Connection
	Module Status (MS)		On	Device Operational
			Flashing	Standby
			Off	No Power
			On	Unclearable Fault
			Flashing	Clearable Fault
			Flashing	Self-Test
Link/Activity		On	Ethernet Connection	
		Off	No Ethernet Connection	

Bus topology example (EtherNet/IP)

We suggest to use Kollmorgen ENCP cables. For more possible system solutions refer to the WorkBench Online Help.

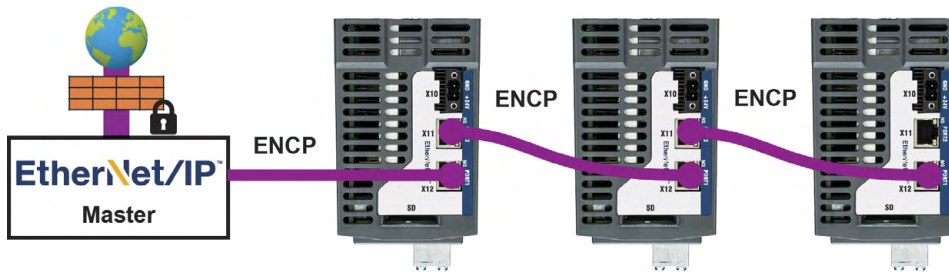

7.13 CAN-Bus Interface connector X13/X14

AKD2G drives with connectivity option C can be connected to a CAN-Bus by using two 6-pin RJ25 connectors X13/X14.

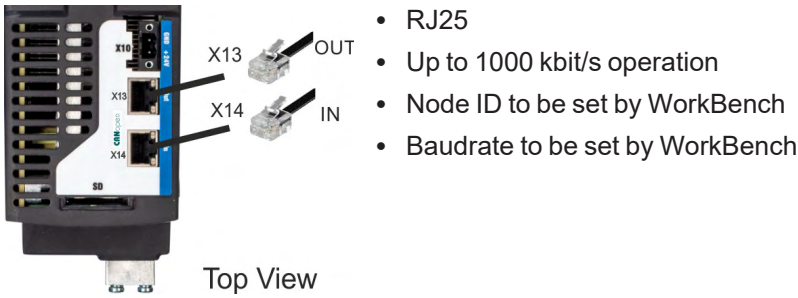

Pin	Signal	Description
1	Termination	Internal Termination Resistor
2	Shield	Chassis
3	CAN_high	CAN bus high signal
4	CAN_low	CAN bus low signal
5	CAN_GND	CAN bus ground
6	Termination	Internal Termination Resistor

7.13.1 CAN-Bus Topology

We recommend the use of Kollmorgen CBP000 cables.

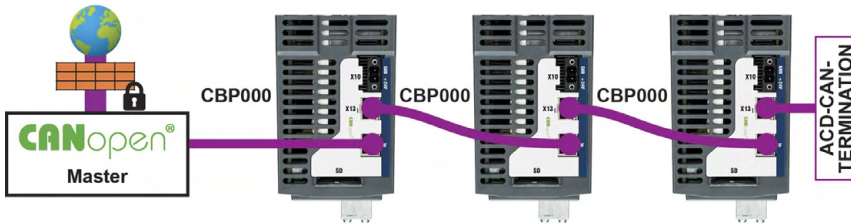

Cable requirements

To meet ISO 11898, a bus cable with a characteristic impedance of 120 Ω should be used. The maximum usable cable length for reliable communication decreases with increasing transmission speed.

As a guide, you can use the following values measured by Kollmorgen; however, these values are not assured limits:

- Characteristic impedance: 100-120 Ω
- Cable capacitance max.: 60 nF / 1000 m
- Lead loop resistance: 159.8 Ω / 1000 m

Transmission Rate (kBaud)	1000	500	250	125
Maximum Cable Length (m)	25	100	250	500

Lower cable capacitance (max. 30 nF / 1000 m) and lower lead resistance (loop resistance, 115 Ω / 1000 m) allow larger distances. The characteristic impedance 150 ± 5 Ω requires terminating resistor 150 ± 5 Ω.

Communication profile

For CANopen communication profile description refer to the manual "AKD2G CAN-Bus Communication".

7.13.2 CAN-Bus Wiring

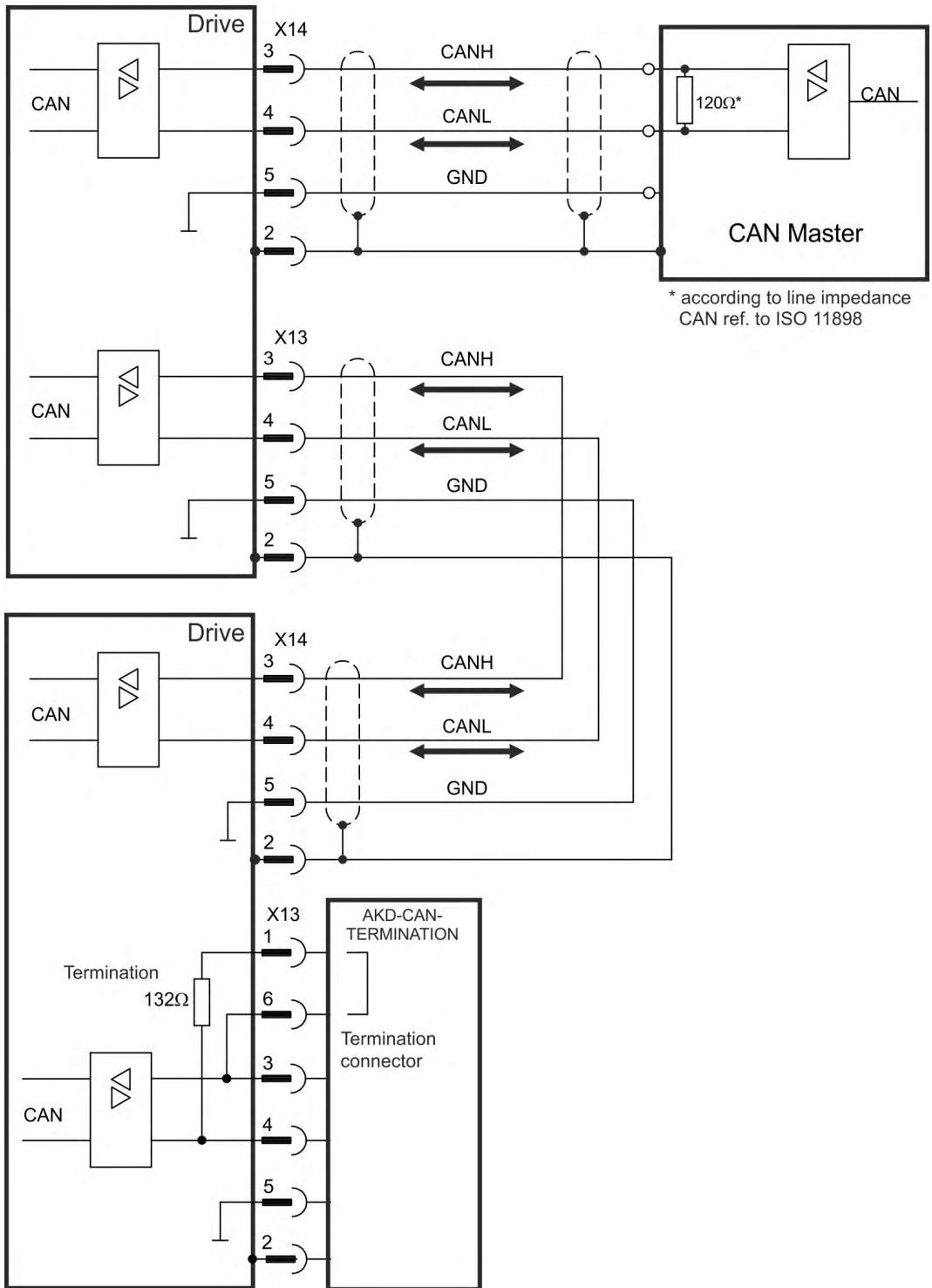

7.13.3 Baud rate for CAN-Bus

The transmission rate can be set by using the parameter **CANBUS.BAUD** in WorkBench.

Baud rate [kBit/s]	CANBUS.BAUD
125	125 (default)
250	250
500	500
1000	1000

With a fix baud rate, the drive sends the boot up message with the baud rate saved in the drive's non volatile memory after a power cycle.

7.13.4 Node Address for CAN-Bus

The node address can be set by using parameter **CANBUS.NODEID** in WorkBench.

NOTE After changing the node address, you must turn off the 24 V auxiliary supply for the drive and then turn it on again.

7.13.5 CAN-Bus Termination

The last bus device on both ends of the CAN-Bus system must have termination resistors. The AKD2G has built-in 132 Ω resistors that can be activated by connecting pins 1 and 6. An optional termination plug is available for AKD2G (*AKD-CAN-TERMINATION*). The optional termination plug is an RJ25 connector with an enclosed wire jumper between pins 1&6. The termination plug should be inserted into the X13 connector of the last drive in the CAN network.

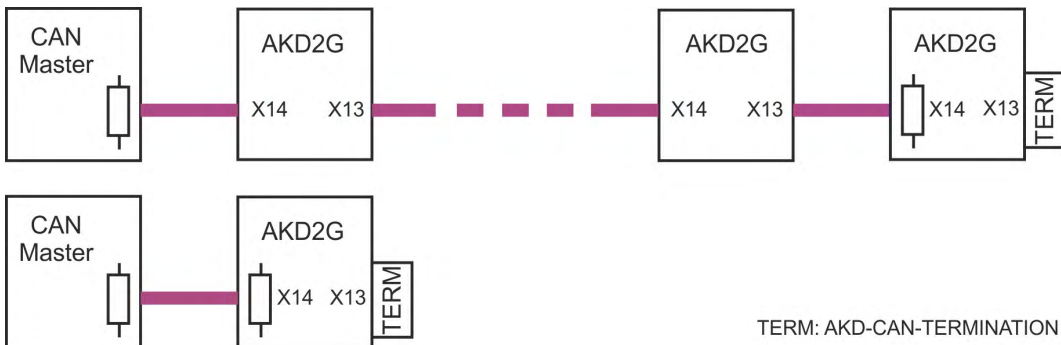

NOTE Remove the termination connector if the AKD2G is not the last CAN-Bus device and use X13 for connecting the next CAN node.

7.14 Service Interface connector X20



- RJ45 with built-in green/red dual-color LED
- 100/10 Mbit Ethernet TCP/IP
- Supports Auto-IP, DHCP and fixed IP addressing
- Supports point-to-point (i.e. Auto-IP) and connection by using network switches
- Supports automatic discovery in WorkBench if in the same sub-net.

Pin	Signal	Description
1	Tx+	Transmit +
2	Tx-	Transmit -

Pin	Signal	Description
3	Rx+	Receive +
4	Termination	Bob Smith termination
5	Termination	Bob Smith termination
6	Rx-	Receive -
7	Termination	Bob Smith termination
8	Termination	Bob Smith termination

Operating, position control and motion-block parameters can be set up by using WorkBench on an ordinary commercial PC (→ # 182).

Connect the service interface X20 of the drive to an EtherNet interface on the PC directly or by using a network switch, **while the supply to the equipment is switched off**. Use standard Cat. 5 EtherNet cables for connection. In some cases crossover cables will also work.

Make sure that the link LED on the AKD2G (RJ45 connector) and on your PC (or network switch) are both illuminated. The electrical connection is well established if both LED's light up green.

7.14.1 Possible Network Configurations

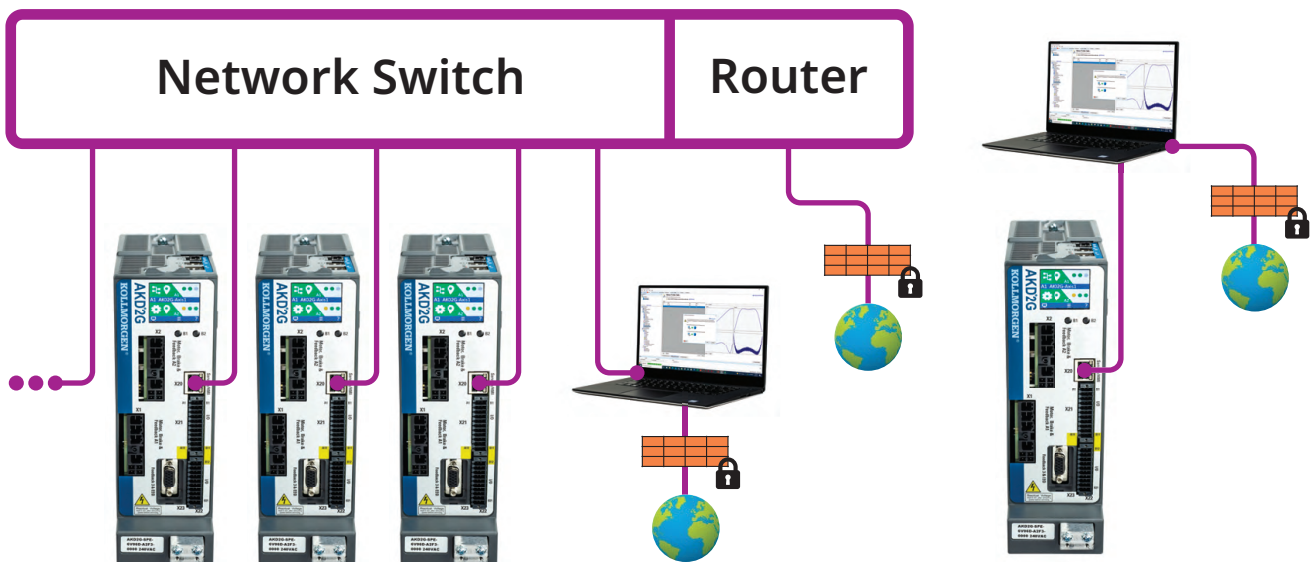

7.15 Modbus TCP connector X20

The drive can be connected to Modbus HMI by using RJ45 connector X20. The protocol allows reading and writing of drive and axis parameters.

The communication status is indicated by the built-in LED.

Connector	LED	Name	Function
X20	LED	IN port Link	green = active, red = not active

Connect the service interface (X20) of the drive to an EtherNet interface on the Modbus HMI directly or by using a network switch, **while the supply to the equipment is switched off**. Use standard Cat. 5 EtherNet cables for connection.

Confirm that the link LED on the AKD2G (the green LED on the RJ45 connector) and on your HMI or switch are both illuminated. If both LEDs are illuminated, then you have a good electrical connection.

The following are required to connect an HMI to the drive:

- The HMI must support Modbus TCP.
- It must have EtherNet hardware and a driver for Modbus TCP, though the driver does not have to be made specifically for the AKD2G family.

The subnet mask of the AKD2G is 255.255.255.0. The first three octets of the drive's IP address must be the same as the first three octets of the HMI's IP address. The last octet must be different.

Modbus TCP and WorkBench/KAS-IDE can operate simultaneously if a switch is used.

Communication profile

For Modbus communication profile description refer to the WorkBench Online Help.

7.16 I/O Connectors X21/X22/X23

X21

- standard
- 2 x 11 pins, pitch 3.5 mm
- A: left connector
- B: right connector



X22

- standard
- 2 x 10 pins, pitch 3.5 mm
- A: left connector
- B: right connector

X23

- standard
- SubD 15 pins HD
- Mating connector: male

X21	Pin	Signal	Pin	Signal
	A1	Analog-In (AIN) 1 +	B1	Analog-Out (AOUT) 1
	A2	Analog-In (AIN) 1 -	B2	AGND
	A3*	Digital-In (DIN) 1	B3	+24 V
	A4*	Digital-In (DIN) 2	B4	DGND
	A5	Digital-In (DIN) 3 (HW-Enable Axis 1)	B5	Digital-Out (DOOUT) 9 + (Relay)
	A6	Digital-In (DIN) 4 (HW-Enable Axis 2)	B6	Digital-Out (DOOUT) 9 - (Relay)
	A7	Digital-In (DIN) 5	B7	SOUT1
	A8	Digital-In (DIN) 6	B8	SOUT2
	A9	Digital-In (DIN) 7	B9	SOUT3
	A10	Digital-In (DIN) 8	B10	SOUT4
	A11	SIN1	B11	SIN2

X22	Pin	Signal	Pin	Signal
	A12	SIN3	B12	SIN4
	A13	Digital-In (DIN) 9	B13	Digital-Out (DOUT) 5
	A14	Digital-In (DIN) 10	B14	Digital-Out (DOUT) 6
	A15	Digital-In (DIN) 11	B15	Digital-Out (DOUT) 7 +
	A16	Digital-In (DIN) 12	B16	Digital-Out (DOUT) 7 -
	A17	AGND	B17	Digital-Out (DOUT) 8 +
	A18	Analog-In (AIN) 2+	B18	Digital-Out (DOUT) 8 -
	A19	Analog-In (AIN) 2-	B19	Analog-Out (AOUT) 2
	A20*	Digital-In/Out (DIO) 1 +	B20*	Digital-In/Out (DIO) 2 +
	A21*	Digital-In/Out (DIO) 1 -	B21*	Digital-In/Out (DIO) 2 -
	X23 (optional)	Pin	Signal	
	2	Digital-In/Out (DIO) 6 +		
	3	Digital-In/Out (DIO) 6 -		
	6	Digital-In/Out (DIO) 5 +		
	7	Digital-In/Out (DIO) 5 -		
	10	+5 V		
	11	0 V		
	12	Digital-In/Out (DIO) 3 +		
	13	Digital-In/Out (DIO) 3 -		
	14	Digital-In/Out (DIO) 4 +		
15	Digital-In/Out (DIO) 4 -			

7.16.1 Technical data

Interface	Electrical Data
Analog inputs Analog-In (AIN) 1 to 2	<ul style="list-style-type: none"> ±10 VDC common mode rejection ratio: > 30 dB at 60 Hz resolution 16 bit and full monotonic update rate: 16 kHz non-linearity < 0.1% of full scale offset drift max. 250 $\mu\text{V}/^\circ\text{C}$ input impedance > 13 kΩ
Analog outputs Analog-Out (AOUT) 1 to 2	<ul style="list-style-type: none"> 0 to +10 VDC, max 20 mA resolution 16 bit and full monotonic update rate: 4 kHz non-linearity < 0.1% of full scale offset drift max. 250 $\mu\text{V}/^\circ\text{C}$ short circuit protected to AGND output impedance 110 Ω
Digital inputs Digital-In (DIN) 1 to 2 IEC 61131-2 Type 1	<ul style="list-style-type: none"> ON: 15 VDC to 30 VDC, 2 mA to 15 mA OFF: -5 VDC to 5 VDC, max. 15 mA galvanic isolation for 60 VDC activation / deactivation delay: < 1 μs / < 1 μs

Interface	Electrical Data
Digital inputs Digital-In (DIN) 3 to 12 IEC 61131-2 Type 1	<ul style="list-style-type: none"> ON: 15 VDC to 30 VDC, 2 mA to 15 mA OFF: -5 VDC to 5 VDC, max. 15 mA galvanic isolation for 60 VDC delay activation / deactivation: about 5 μs / 500 μs
Digital outputs Digital-Out (DOUT) 5 to 6	<ul style="list-style-type: none"> max. 30 VDC, 100 mA short circuit proof galvanic isolation for 60 VDC delay activation / deactivation: about 5 μs / 300 μs
Digital outputs Digital-Out (DOUT) 7 to 8	<ul style="list-style-type: none"> volt-free contacts, max 30 VDC, 100 mA sink or source galvanic isolation for 24 VDC from PE delay activation / deactivation: about 5 μs / 50 μs
Digital inputs/outputs Digital-In/Out (DIO) 1 to 6	<ul style="list-style-type: none"> RS485, 5V, max 100mA reference potential X22: AGND, X23: 0V input OFF: -0.3 V to +0.3 V selectable termination, difference/single ended delay activation / deactivation: about 50 ns
Digital output Digital-Out (DOUT) 9	<ul style="list-style-type: none"> max. 30 VDC, 1A max. 42 VAC, 1 A galvanic isolation for 24 VDC from PE delay open/close: 10 ms / 10 ms
Safe digital inputs SIN1 to SIN4	<ul style="list-style-type: none"> ON: > 15 VDC, > 2 mA, OFF: < 5 VDC, < 1 mA galvanic isolation for 60 VDC delay activation / deactivation about: 1.5 ms / 3.5 ms test pulse are required
Safe digital outputs SOUT1 to SOUT4	<ul style="list-style-type: none"> volt-free contacts, max 30 VDC, 172 mA short circuit proof galvanic isolation for 24 VDC from PE activation delay (0->1) depends on the safety function hardware deactivation delay (1>0) about 300 μs emits test pulses

7.16.2 Analog Input

The drive is fitted with differential inputs for analog torque, velocity, or position control. The standard drive offers one analog input on X21, dual axis drives and drives with built-in option IO or DX offer a second analog input on X22.

NOTICE

Maximum distance for unshielded I/O lines is 3 m inside the cabinet. If the I/O cable leaves the cabinet, it must be EMC shielded.

Technical characteristics

- Differential input voltage range: ± 10 V
- Maximum input voltage referring to I/O Return: -12.5, +16.0 V
- Resolution: 16 Bit and fully monotonic
- Firmware update rate: 16 kHz
- Unadjusted offset: < 50 mV
- Offset drift typ: 250 μ V / $^{\circ}$ C
- Gain or slope tolerance: +/- 3%

- Nonlinearity: < 0.1% of full scale or 12.5 mV
- Common Mode Rejection Ratio: > 30 dB at 60 Hz
- Input impedance: > 13k Ω s
- Signal to noise ratio referred to full scale:
 - AIN.CUTOFF = 3000 Hz: 14 bit
 - AIN.CUTOFF = 800 Hz: 16 bit

Analog Input Wiring Diagram

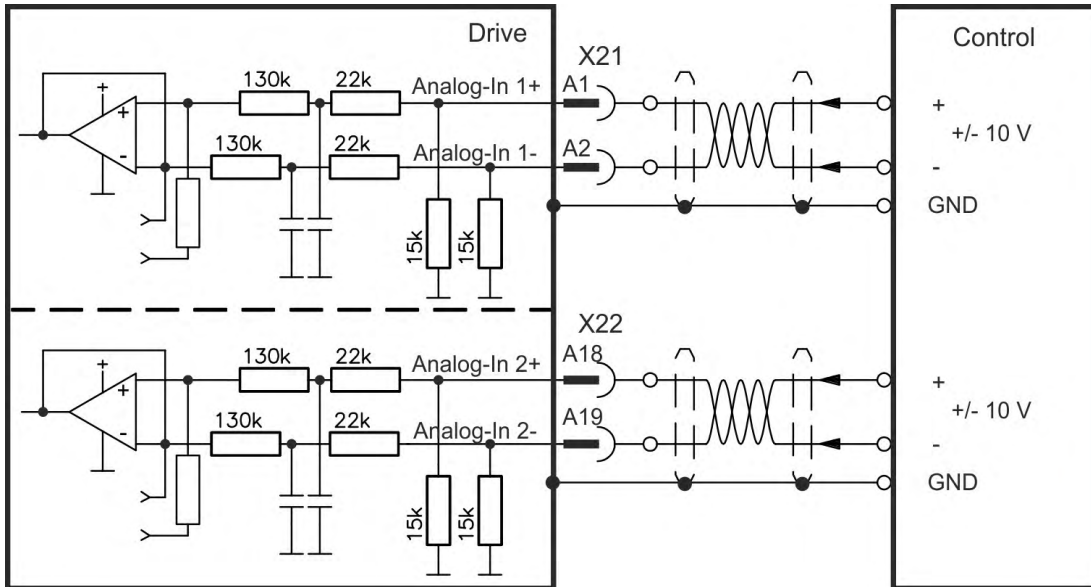

Application examples for set point input Analog-In:

- reduced-sensitivity input for setting-up/jog operation
- pre-control/override

Defining the direction of rotation

Standard setting: clockwise rotation of the motor shaft (looking at the shaft end) affected by positive voltage between terminal (+) and terminal (-)

To reverse the direction of rotation, swap the connections to terminals +/- or change parameter AXIS#.DIR in WorkBench.

7.16.3 Analog Output

Analog Outputs can be used to output converted analog values of digital measurements recorded in the drive. The standard drive offers one analog output on X21, dual axis drives and drives with built-in option IO or DX offer a second analog output on X22.

NOTICE

Maximum distance for unshielded I/O lines is 3 m inside the cabinet. If the I/O cable leaves the cabinet, it must be EMC shielded.

Technical characteristics

- Output voltage range referring to AGND: 0 to 10 V
- Resolution: 16 Bit and fully monotonic
- Update rate: 4 kHz
- Unadjusted offset: < 50 mV
- Offset drift typ: 250 $\mu\text{V}/^\circ\text{C}$
- Gain or slope tolerance: +/- 3%
- Nonlinearity: < 0.1% of full scale or 20 mV
- Output impedance: 110 Ω
- Specification complies with IEC 61131-2 Table 11
- -3 dB Bandwidth: >8 kHz
- Maximum output current: 20 mA
- Capacitive load: any value but response speed limited by max Iout and by Rout
- Protected for short circuit to AGND

Analog Output Wiring Diagram

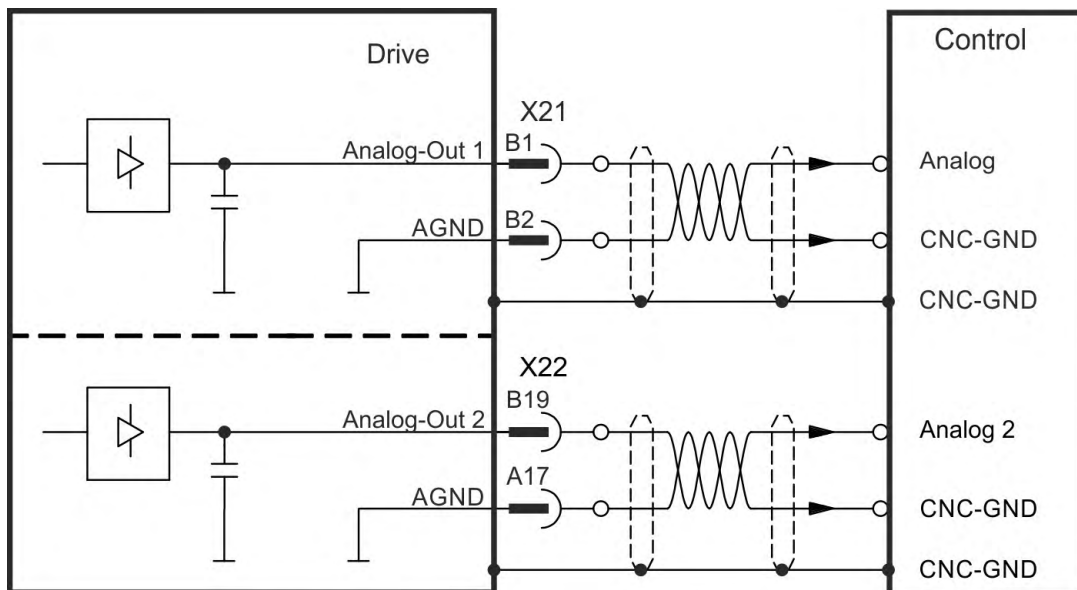

7.16.4 Digital Inputs

The drive provides 8 digital inputs on X21. Dual axis drives and drives with built-in option IO or DX offer additional 4 inputs on X22 and 2 programmable Input/Outputs on X22. If X23 is built-in and not used for feedback or EEO function, then it offers 4 additional programmable Input/Outputs.

All inputs can be used to initiate pre-programmed actions. A list of actions is included in WorkBench. If an input is programmed, it must be saved to the drive.

The drive provides 4 safe digital inputs on X21 and X22. These inputs can be used as safe inputs, based on the installed functional option (→ # 210).

NOTICE

Maximum distance for unshielded I/O lines is 3 m inside the cabinet. If the I/O cable leaves the cabinet, it must be EMC shielded.

NOTE

Depending on the selected function, the inputs are high or low active. Digital input filter can be set in WorkBench to change sensitivity of the inputs (see Online Help).

7.16.4.1 Digital-In 1 and 2

These inputs (IEC 61131-2 Type 1) are particularly fast and are therefore suitable for position latch functions. They can also be used as 24 V inputs for electronic gearing (→ # 151).

Technical characteristics

- Floating, reference common line is DGND
- High: 15 to 30 V/2 to 15 mA , Low: -5 to +5 V/<15 mA
- Update rate: firmware reads hardware input state every 250 μ s
- High accuracy latch: motor feedback position or interpolated time is latched or captured within 2 μ s of input signal transition (with digital input filter set to 40 ns)
- The AKD2G capture engine is polled every 62.5 μ s (16 kHz) by the firmware

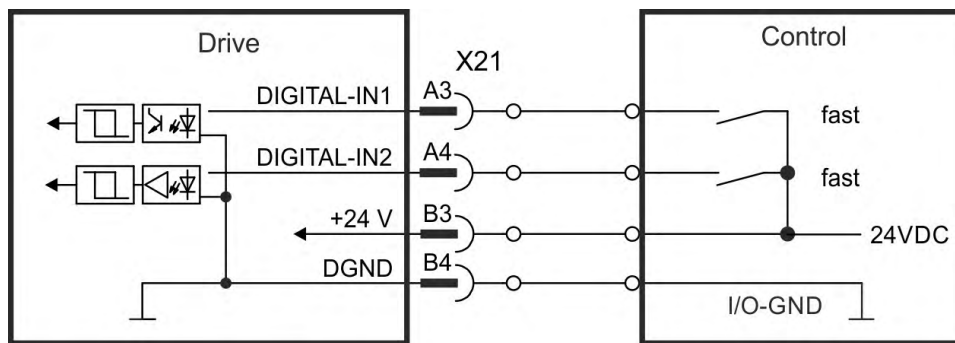
Wiring example

7.16.4.2 Digital-In 3 to 12

These inputs (IEC 61131-2 Type 1) are programmable with WorkBench.

Manufacturer setting:

- Digital-In 3: HW-Enable Axis 1
- Digital-In 4: HW-Enable Axis 2
- Digital-In 5 ...12: off

Choose the function you require in WorkBench and refer to the software for more information.

Technical characteristics

- Floating, reference common line is DGND
- High: 15 to 30 V/2 to 15 mA , Low: -5 to +5 V/<15 mA
- Update rate: firmware reads hardware input state every 250 μ s

Wiring example

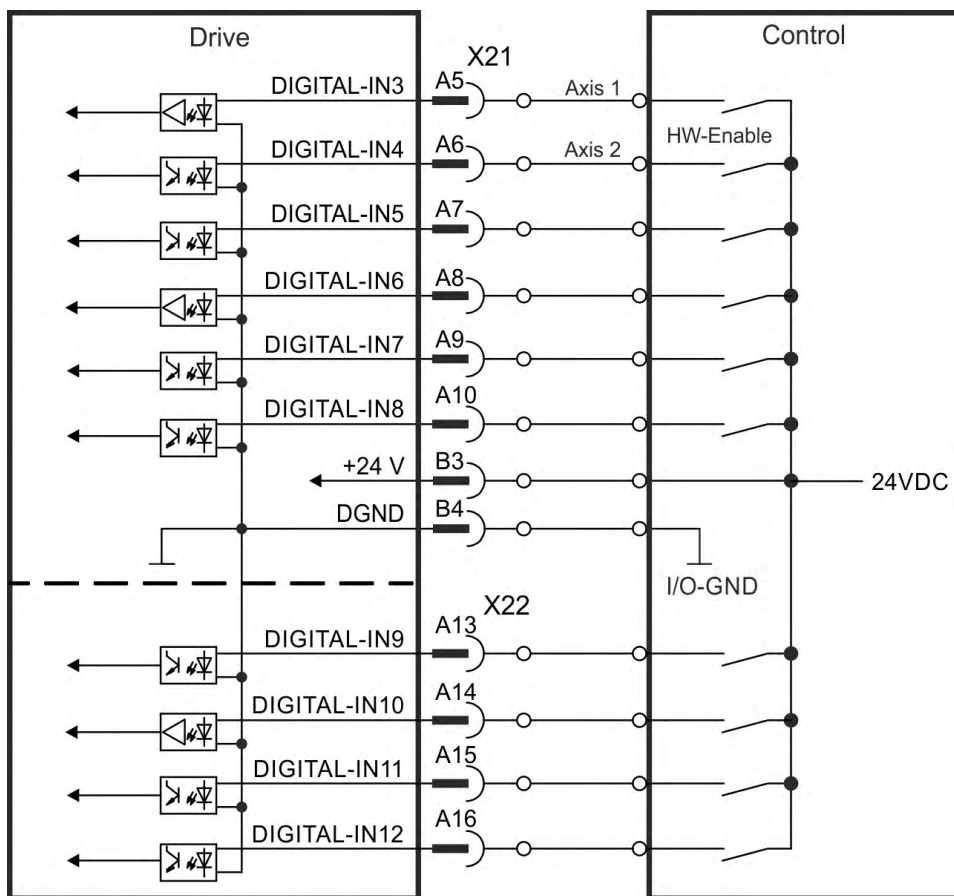

7.16.4.3 Digital-In/Out 1 and 2

Pins X22/A20-A21 (Digital-In/Out 1) and X22/B20-B21 (Digital-In/Out 2) can be defined as either inputs or outputs. For programming refer to WorkBench.

NOTICE

NOT compatible with 24V signal level! Will be damaged if connected to +24V!

Technical characteristics when configured for input:

- RS485 common is AGND; not optically isolated
- No wire break detection
- Termination Selection: Unterminated or DC Terminated
- Differential or Single-ended
 - For single-ended:
 - Negative terminal is open circuit; Positive input high signal = 3 - 5 V.
 - Force input high with 5 V driver applied to DIO1/2+; pull input low by sinking DIO1/2+ to AGND. Open circuit (floating) input will typically be high.
- Update rate: firmware reads hardware input state every 250 μ s
 - When used for capture, timing resolution is <1 μ s

Wiring example

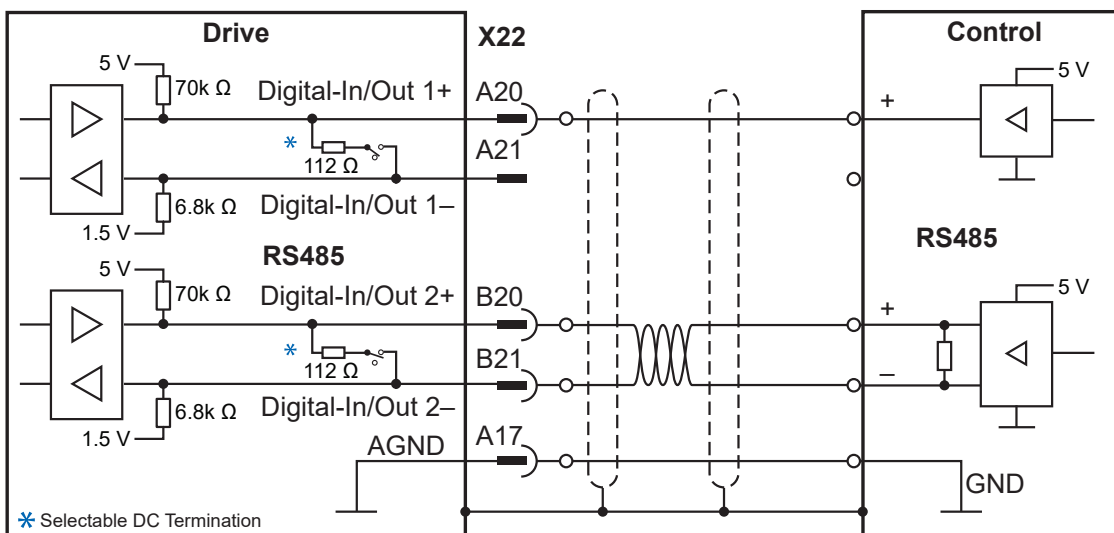

7.16.4.4 Digital-In/Out 3 to 6

X23 can be used for digital I/O. The channels can be defined as inputs or outputs. For programming refer to WorkBench.

NOTICE NOT compatible with 24 V signal level! Will be damaged if connected to +24 V!

Technical characteristics when configured for input:

- RS485 reference common line is 0 V
- No wire break detection
- DIO 3/4 Termination Selection: Unterminated (AC Termination) or DC Terminated
- DIO 5 Termination Selection: Unterminated (AC Termination) or DC Terminated on newer models*
- DIO 6 Termination Selection: Unterminated (AC Termination) Only
- Differential only
- Update rate: firmware reads hardware input state every 250 μ s
 - When used for capture, timing resolution is <1 μ s

Wiring example

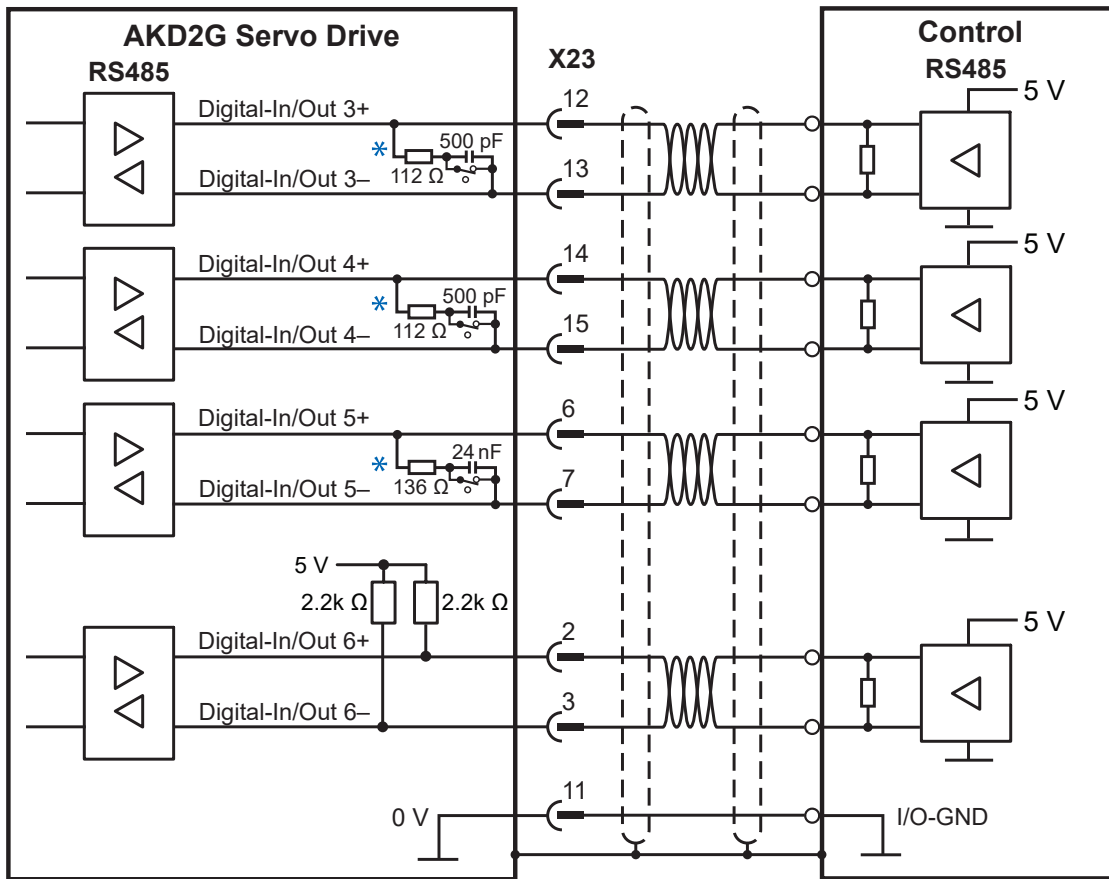

* AC / DC Selectable Termination
Older drives may not include a DC termination switch across DIO5 (Pins 6 and 7). Please contact Kollmorgen Support for more information.

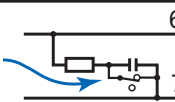

7.16.5 Digital Outputs

The drive provides 4 safe digital outputs on X21. These outputs can be used as safe outputs see (→ # 211). For more information refer to WorkBench.

Dual axis drives and drives with built-in option IO or DX offer additional 4 digital outputs and 2 programmable Input/Outputs. If X23 is built-in and not used for feedback or EEO function, then it offers 4 additional programmable Input/Outputs.

The relay output can be used as fault or ready to operate signal.

NOTICE

Maximum distance for unshielded I/O lines is 3 m inside the cabinet. If the I/O cable leaves the cabinet, it must be EMC shielded.

Choose the required action in WorkBench. A list of actions is included in the software. If an output is programmed, it must be saved to the drive.

7.16.5.1 Digital-Out 5 to 6

These outputs are programmable with WorkBench. By default, all outputs are not programmed (off).

Technical characteristics

- The outputs can switch +5 V to +30 V
- All digital outputs are floating
- High side, output current max. 100 mA
- Update rate: 250 μ s

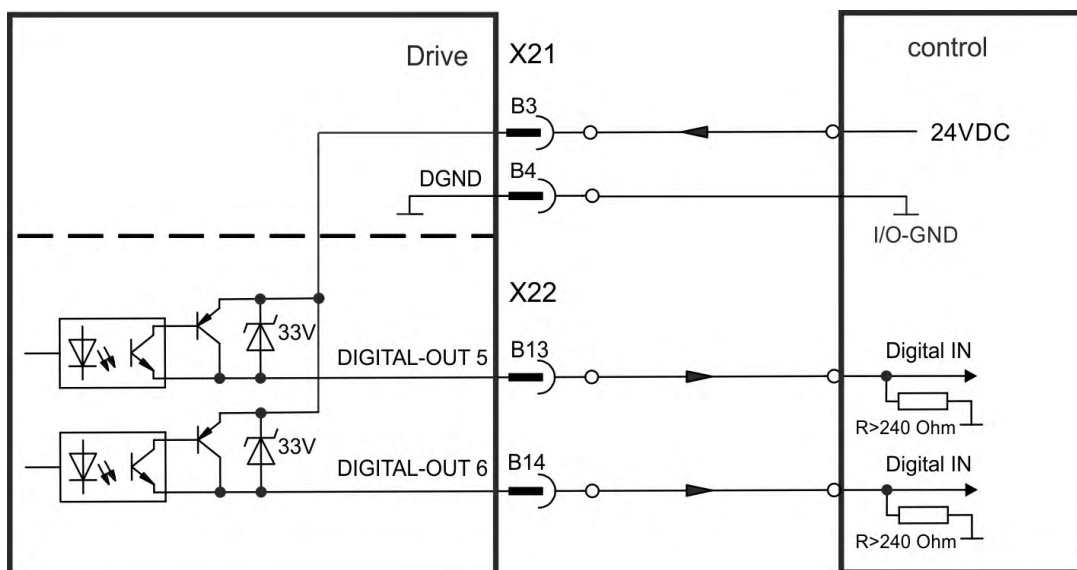

7.16.5.2 Digital-Out 7 and 8

These outputs are programmable with WorkBench. By default, all outputs are not programmed (off).

Technical characteristics

- The outputs can switch +5 V to +30 V
- Galvanic isolation for 24 VDC from PE
- The two channels are isolated from one another and not referred to a common potential
- Output current max. 100 mA
- Can be wired as sinking or sourcing (see examples below)
- Update rate: 250 μ s

Wiring examples

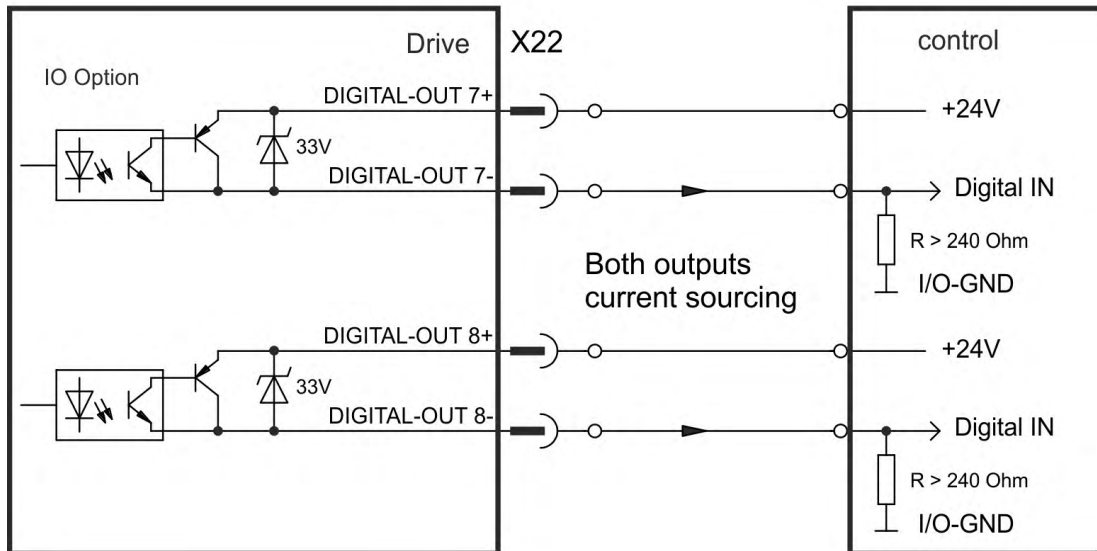
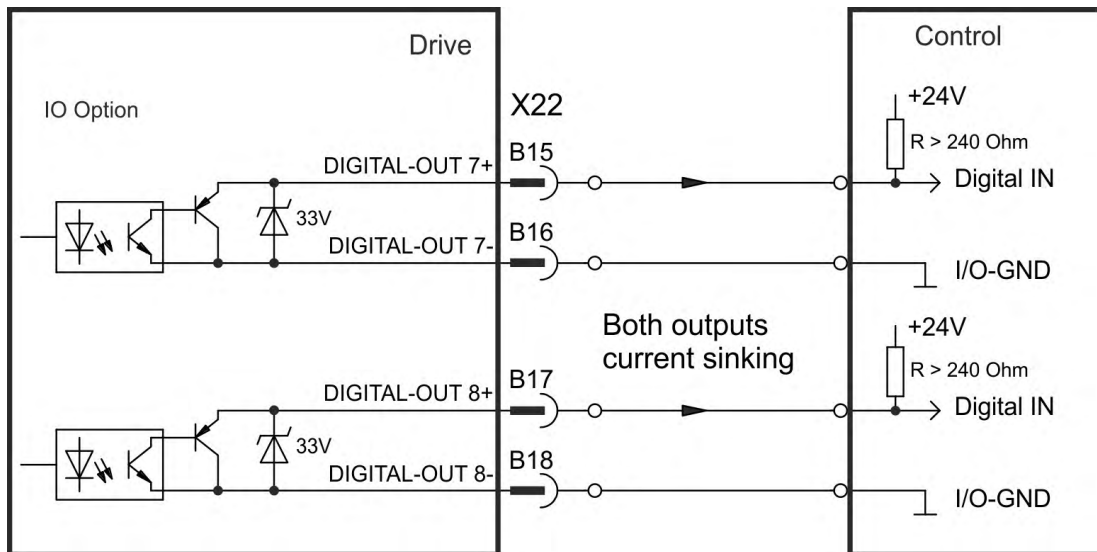

7.16.5.3 Digital-In/Out 1 and 2

Pins X22/A20-A21 (Digital-In/Out 1) and X22/B20-B21 (Digital-In/Out 2) can be used as either inputs or outputs. For programming refer to WorkBench.

Technical characteristics if configured as output

- RS485, reference common line is AGND
- No wire break detection
- Termination Selection: Unterminated (recommended) or DC Terminated
- Differential or single-ended
 - For single-ended: Negative terminal is open circuit
- Update rate: 250 μ s

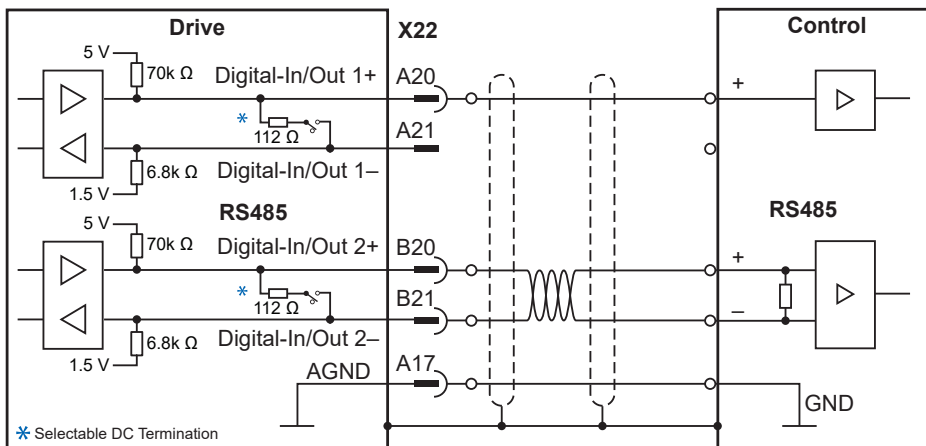

7.16.5.4 Digital-In/Out 3 to 6

X23 can be used for digital I/O. The channels can be defined as inputs or outputs. For programming refer to WorkBench.

Technical characteristics if configured as output

- RS485, reference common line is 0V
- No wire break detection
- DIO 3/4 Termination Selection: Unterminated (AC Termination) (recommended) or DC Terminated
- DIO 5 Termination Selection: Unterminated (AC Termination) (recommended) or DC Terminated on newer models*
- DIO 6 Termination Selection: AC termination only
- Differential or single-ended
 - For single-ended: Negative terminal is open circuit
- Update rate: 250 μ s

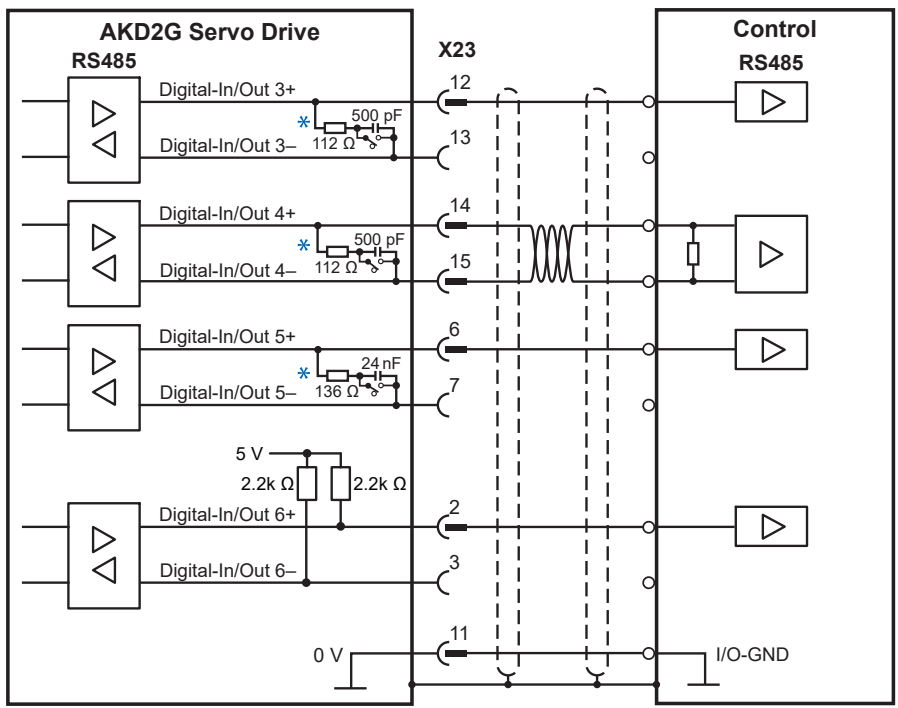

* AC / DC Selectable Termination
 Older drives may not include a DC termination switch across DIO5 (Pins 6 and 7).
 Please contact Kollmorgen Support for more information.

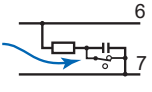

7.16.5.5 Digital-Out 9, Relay contacts

Digital-Out 9 is programmable with WorkBench.

By default, the output function is defined as ready to operate output by action parameter.

NOTICE

If an inductive load (relay or similar) is used, a freewheeling diode must be added to the load.

Technical characteristics

- Relay output, max. 30 VDC or 42 VAC, 1 A
- Galvanic isolation for 24 VDC from PE
- Time to close: max. 10 ms
- Time to open: max. 10 ms

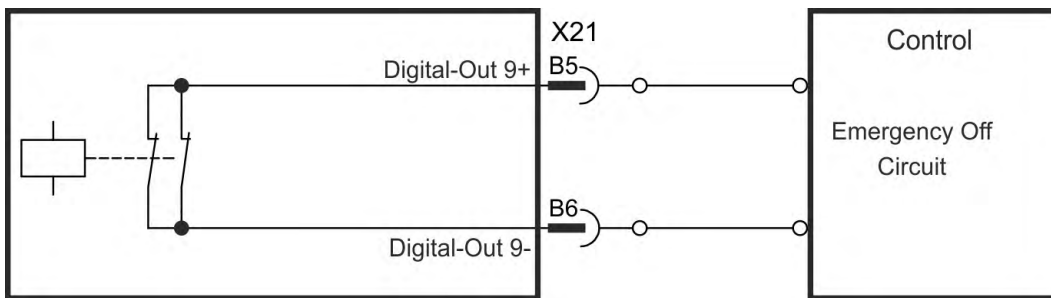

8 Setup

8.1 Important Notes	177
8.2 Guide to drive setup	178
8.3 Switch-On and Switch-Off Behavior	183
8.4 Fault and Warning Messages	191
8.5 Troubleshooting	192

8.1 Important Notes

NOTICE

Only professional personnel with extensive knowledge in the fields of electrical engineering and drive technology are allowed to test and set up the drive.



⚠ DANGER Lethal Voltage!

There is a danger of serious personal injury or death by electrical shock. Lethal danger exists at live parts of the device.

- Built-in protection measures such as insulation or shielding may not be removed.
- Work on the electrical installation may only be performed by trained and qualified personnel, in compliance with the regulations for safety at work, and only with switched off mains supply, and secured against restart.
- In normal operation, the cabinet door must be closed and the device must not be touched.



⚠ WARNING Automatic Restart!

Risk of death or serious injury for humans working in the machine. The drive might restart automatically after power on, voltage dip or interruption of the supply voltage, depending on the parameter setting. If parameter AXIS#.ENDEFAULT is set to 1,

- then place a warning sign ("WARNING: Possible Automatic Restart" or similar) to the machine.
- Ensure, that power on is not possible, while humans are in a dangerous zone of the machine.



⚠ CAUTION High Temperature!

Risk of minor burns. The heat sink of the drive can reach temperatures up to 80°C in operation.

- Check the heat sink temperature before handling the drive.
- Wait until the heat sink has cooled down to 40°C before touching it.



⚠ WARNING Projection of molten particles!

If particles fall into the drive or the drive has been damaged, molten drive component particles may be ejected causing injuries. Shut down the drive and wear appropriate protective gear during maintenance work, troubleshooting and fault rectification. (→ # 34)

NOTICE

If the drive has been stored for more than 1 year, you must re-form the capacitors in the DC bus link circuit. Re-forming procedures are described in the KDN ([Forming](#)).

NOTE

Additional information on setting up the equipment:

- Programming parameters and control loop behavior are described in the AKD2G User Manual (Online Help), see [Configuring the Command Source and Operating Mode](#).
- The setup of any fieldbus is described in the corresponding manual.

8.2 Guide to drive setup

NOTICE

Setup must be done in two major steps:

1. Drive setup (this section). This section presents an example to test the drive initially. If the drive (motor, feedback, control circuits, I/Os) is well parameterized, then proceed with the
2. Functional Safety setup (→ # 201).

8.2.1 Initial Drive Test Procedure

8.2.1.1 Unpacking, mounting, and wiring the AKD2G

1. Unpack the drive and accessories.
2. Mount the drive.
3. Wire the drive or apply the minimum wiring for drive testing as described below.
4. Make sure you have on hand the following information about the drive components:
 - rated mains supply voltage
 - motor type (motor data, if the motor type is not listed in the motor database)
 - feedback unit built into the motor (type, poles/lines/protocol)
 - moment of inertia of the load

8.2.1.2 Minimum wiring for drive test without load, example

NOTICE

This wiring diagram based on default settings is for general illustration only and does not fulfill any requirements for EMC, functional safety, or functionality of your application.

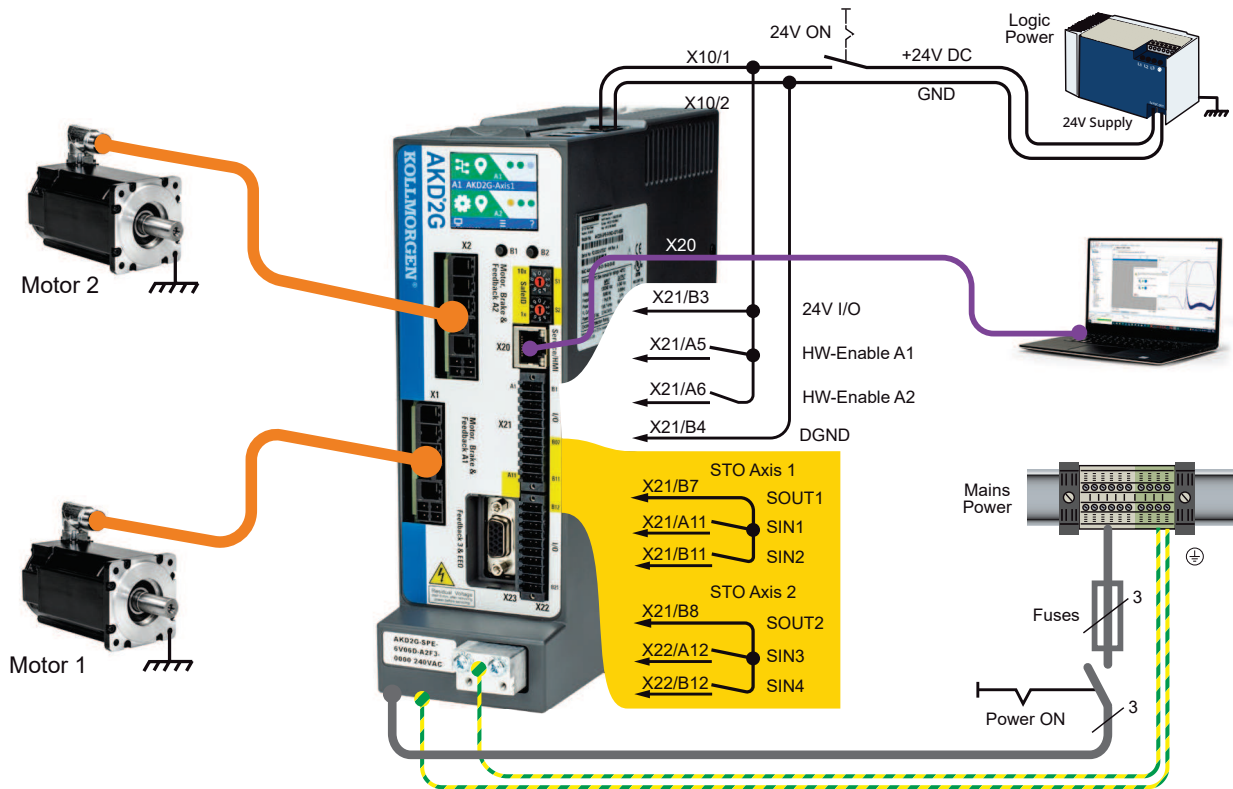

8.2.1.3 Confirm connections (example: directly to PC)

You can turn on logic power to the drive through the X10 connector (mains power voltage is not needed for communications).

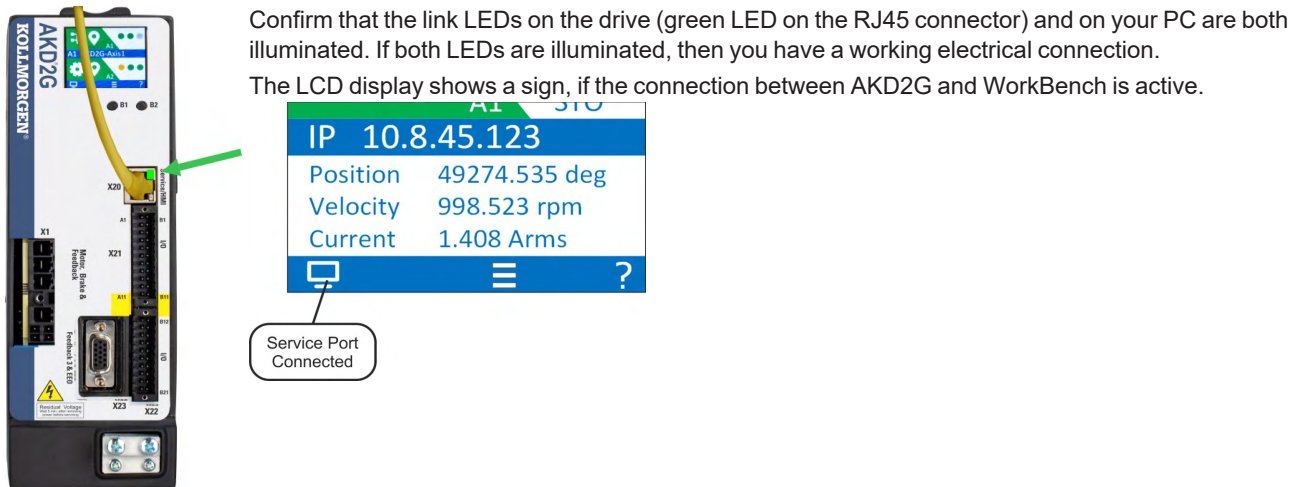

Use WorkBench to configure the drive by using the service interface.

8.2.1.4 System integration

MAC Address

The unique MAC address is pre-defined by the manufacturer (see nameplate).

Service IP Address

The AKD2G service port X20 supports auto-IP, DHCP and static IP addressing.

The drive is delivered with IP address 0.0.0.0. Depending on the connection (switch or PC) either DHCP or auto-IP mechanism assigns a unique IP address.

WorkBench uses the IP address to detect AKD2G devices in the LAN and start communication. With WorkBench you can set a static IP address for the drive (parameter *IP.ADDRESS*).

EtherCAT Node Address

The EtherCAT node address is assigned automatically by the EtherCAT master.

CAN Node ID

Set a CAN node ID for the drive in WorkBench (parameter *CANBUS.NODEID*).

PROFINET

The station name and IP address must be set manually through the PROFINET master.

SafelD

Every module must have a unique SafelD in the safety system. Set the SafelD for every module with the two decimal rotary switches in the front.

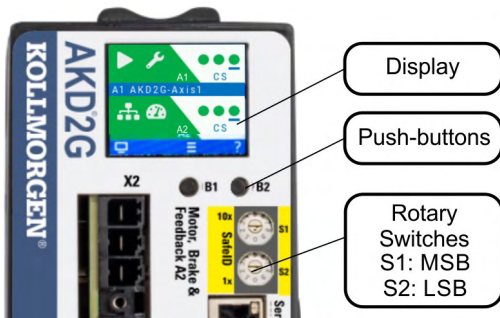

Process to set the SafelD

1. Switch off 24V supply voltage.
2. Set S1 and S2 to a unique SafeID.
3. Switch on the 24V supply voltage.

The SafeID is calculated based on the rotary switches setting:

$$\text{SafeID} = 10 \cdot S1 + S2$$

Example

Rotary switches: S1 = 2, S2 = 3 → SafeID = $10 \cdot 2 + 3 = 23$

Factory default setting

Rotary Switch setting S1 = 0, S2 = 1. Resulting SafeID is 1.

FSoE Address

The unique FSoE address for every axis is derived from the set SafeID.

FSoE address for axis 1 = SafeID • 100 + 1

FSoE address for axis 2 = SafeID • 100 + 2

Example

Rotary switches setting: S1 = 2, S2 = 3 → SafeID = $10 \cdot 2 + 3 = 23$

Resulting FSoE address for axis 1 = $23 \cdot 100 + 1 = 2301$

Resulting FSoE address for axis 2 = $23 \cdot 100 + 2 = 2302$

Factory default setting

Rotary Switch setting S1 = 0, S2 = 1. Resulting SafeID is 1.

Resulting FSoE address for axis 1 = $1 \cdot 100 + 1 = 101$

Resulting FSoE address for axis 2 = $1 \cdot 100 + 2 = 102$

8.2.1.5 Install and start WorkBench

WorkBench is available on the Kollmorgen website. Select the install file and follow the instructions given by the installer.

Once the installation is complete, click the WorkBench icon to start the program.

8.2.1.6 Setup the axis in WorkBench

Use the setup wizard and

1. Connect the axis
2. Setup the axis
3. Save the parameter set to the drive

Refer to the WorkBench Online Help for details.

8.2.1.7 Enable the axis (Hardware)

1. Switch 24 V to the STO inputs (X21/A11-B11 for axis 1 or X21/A12-B12 for axis 2)
2. Switch 24 V to the digital inputs for Hardware Enable Axis 1 (X21/A5) or 2 (X21/A6).

8.2.1.8 Move the motor axis

1. Select the Axis in WorkBench
2. Under Motion, select **Service Motion**
3. Select **Reversing**, check the default velocity and time settings for plausibility
4. Select **Start**.

8.2.1.9 Tune the axis

Details see *WorkBench Online Help*

8.2.2 WorkBench Installation

This chapter describes the installation of the WorkBench software for AKD2G drives. Kollmorgen offers training and familiarization courses on request.

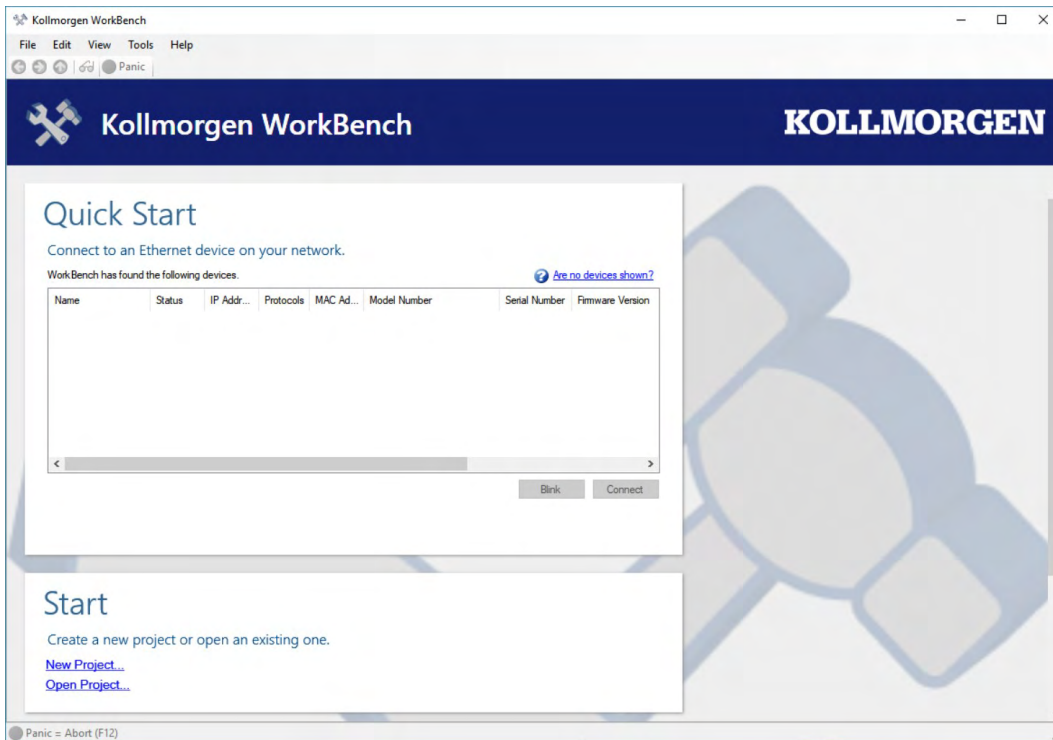

8.2.2.1 Use as directed

With the software to set up your drive you can alter and save the operating parameters for the AKD2G series of drives. The attached drive can be set up with the help of this software. During this procedure the drive can be controlled directly by the service functions.

Only professional personnel who have the relevant expertise (→ # 23) are permitted to carry out online parameter setting for a drive that is running.

Sets of data that have been stored on data media are not safe against unintended alteration by other persons. The use of unchecked data can result in unexpected movement. After loading a set of data always validate parameters which are relevant for the application before enabling the drive.

8.2.2.2 Software description

Each drive must be configured according to the requirements of your machine. For most applications you can use a PC and WorkBench (the software to setup your drive) to set up the operating conditions and parameters for your drive.

An EtherNet cable connects the PC with the drive (→ # 160) WorkBench establishes the communication between PC and drive.

Please find the software to set up your drive in the download area of the Kollmorgen website.

With WorkBench you can

- easily change parameters and directly see what happens with your drive due to a continuous online connection to the drive,
- read important and actual values from the drive which are displayed on the PC (oscilloscope functions),
- save data sets on data media (archiving) and load them onto other drives or use them for backup and
- print data sets.

Most standard feedback systems are plug and play compatible. Motor nameplate data is stored in the feedback device and read by the drive automatically at startup. Non-plug and play Kollmorgen motors are stored in WorkBench and can be loaded with one-click using the Motor screen in the software.

An extensive online help with integrated description of all variables and functions supports you in each situation.

8.2.2.3 Hardware requirements

The Service interface (X20, RJ45) of the drive is connected to the EtherNet interface of the PC by an EtherNet cable (→ # 160).

Minimum requirements for the PC:

Processor: at least 1 GHz

RAM: 2 GB

Graphics adapter: Windows compatible, color, minimum 1024 x 768 dpi

Drives: hard disk with at least 500 MB free space

Interface: one free Ethernet Interface or Switch port

8.2.2.4 Operating systems

Windows 7/8/10/11

- WorkBench works with Windows 7, 8, 10 and 11
- .Net framework 4.8.1 or higher is required
- Visual C++ Redistributable (2010, 2013, 2015)
- Internet Explorer 10 or higher

Unix, Linux

The software does not run on Unix/Linux.

8.2.2.5 Installation under Windows 7/8/10/11

Use WorkBench to setup your drive. You can download the latest version from the Kollmorgen website.

Install the WorkBench as follows:

1. Download one of the following installation packages from www.kollmorgen.com:
 - Standard installation: Contains the application with complete help files. Dependencies like for example the .NET Framework will be downloaded from the internet if not already installed.
 - Full installation: Contains the application with complete help files and embedded dependencies like for example the .NET Framework.
2. After complete download, double-click on the downloaded file and follow the instructions.

EtherNet interface connection

- Connect the interface cable to an EtherNet interface on your PC or to a switch and to the AKD2G service interface X20 (→ # 160).

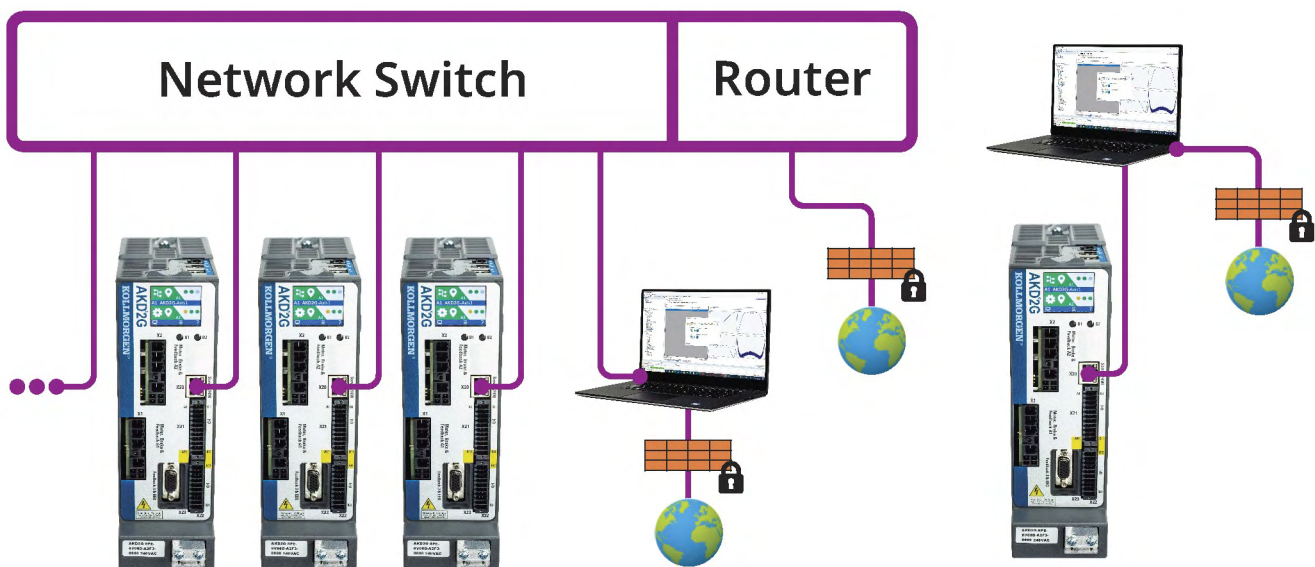

The LCD display shows a sign when AKD2G and WorkBench are connected.

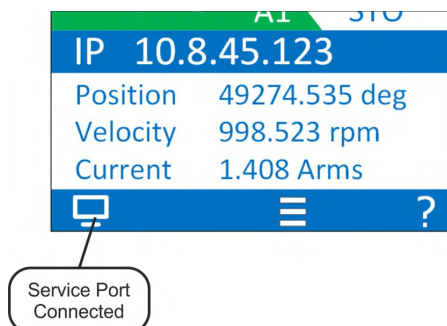

8.3 Switch-On and Switch-Off Behavior

This chapter describes the switch-on and switch-off behavior of the AKD2G with STO.

Behavior of “holding brake” function

Drives with an enabled holding brake function have a special timing for switching on and off the output stage (→ # 113). Events that remove the `AXIS#.ACTIVE` signal trigger the holding brake to apply. As with all electronic circuits, the general rule applies that there is a possibility of the internal holding brake module failing.

If the drive detects the motor to be at zero velocity (as configured by `AXIS#.ZEROT` and `AXIS#.ZEROV`) or timeout occurs during a stop procedure, the brake is applied. Set parameter `AXIS#.MOTOR.BRAKEIMM` to 1 with vertical axes, to apply the motor holding brake (→ # 113) immediately after faults or Hardware Disable.

Behavior when undervoltage condition is present

The behavior in an undervoltage condition depends on the `VBUS.UVMODE` setting.

VBUS.UVMODE	DC Bus Undervoltage Mode. Consult the WorkBench Online Help for configuring the parameter.
0	The drive will report a F2007 undervoltage fault any time an undervoltage condition occurs.
1 (default)	The drive will report a warning W2007 if not enabled. The drive will report a fault if the drive is enabled when the condition occurs, or an attempt is made to enable while an under voltage condition occurs.

Functional Safety

The drive can be braked down using `SS1` and `SDB` and secured to standstill with `SBC` and `STO`. Even when power is being supplied, the drive shaft is protected against unintentional restart. The chapter “Functional Safety” describes how to use the safety functions (→ # 195).

- Functional Safety can be ensured with configured `SBC` (→ # 240) only.
- For SIL 3 a second (external) motor brake for an axis is required. For single axis drives this brake can be connected to `X4` (→ # 115). For dual axis drives the additional brake must be controlled from another source (e.g. from the other axis or externally from a safety controller). The brakes can be mapped to an axis with WorkBench.
- The Hardware Enable does not initiate a controlled stop but switches off the power stage immediately.
- Set parameter `AXIS#.MOTOR.BRAKEIMM` to 1 with vertical axes, to apply the brake immediately after faults or Hardware Disable.

8.3.1 Switch-on behavior in standard operation

The diagram below illustrates the correct functional sequence for switching the drive on.

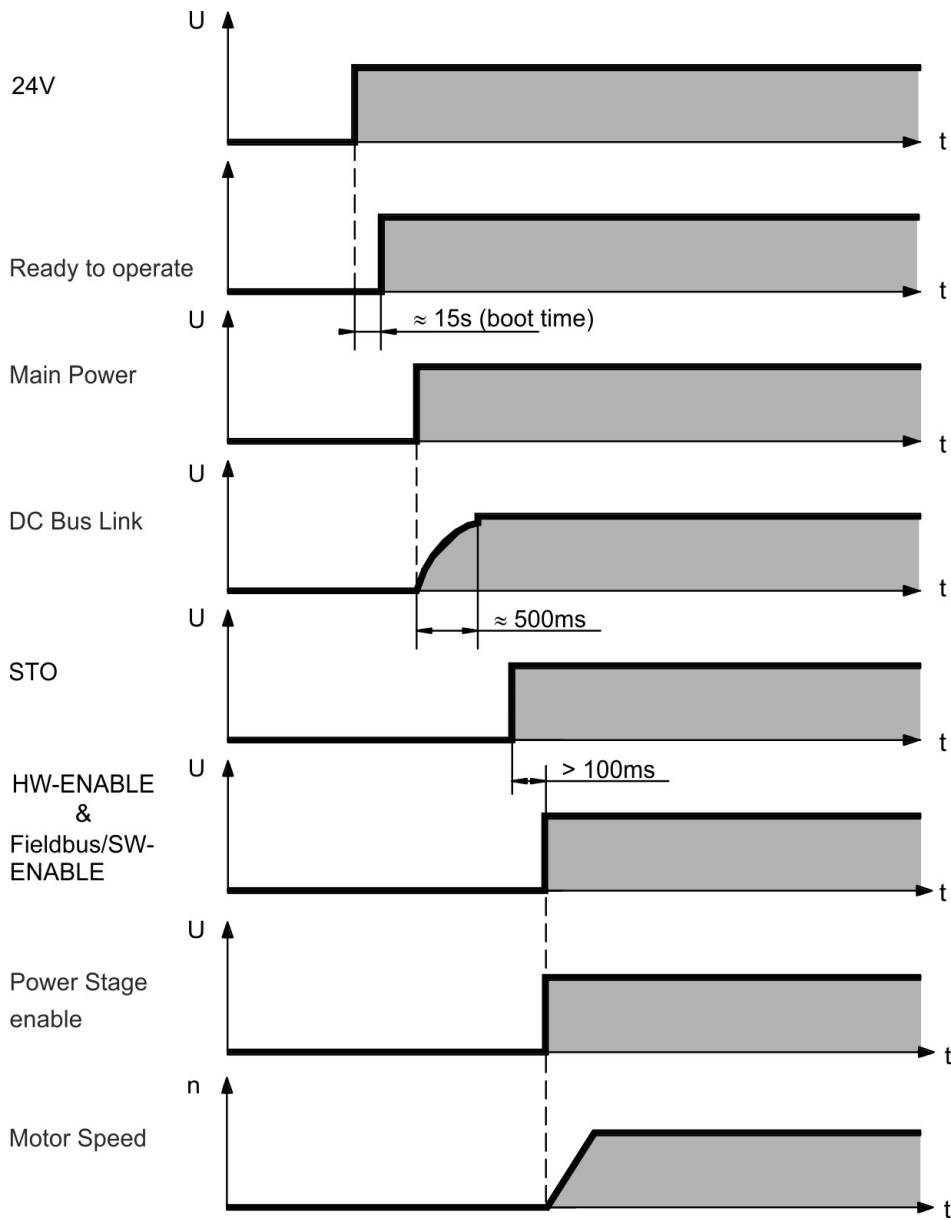

8.3.2 Switch-off behavior

NOTE The drive's 24V supply must remain constant. STO disables the power stage immediately. Configured digital inputs and fieldbus commands can be used to perform controlled stops.

8.3.2.1 Switch-off behavior using the AXIS#.DIS command

The enable/disable button in WorkBench issues a *AXIS#.DIS* command internally to the drive. See *WorkBench Online Help* for configuring inputs and software commands. Sometimes this enable signal is called "Software Enable" (SW-Enable).

AXIS#.DISMODE	AXIS#.DISMODE controls the behavior of the <i>AXIS#.DIS</i> command issued through WorkBench, or terminal, or fieldbus.
0	Disable axis immediately, if the drive detects the motor to be at zero velocity <i>AXIS#.ZEROV</i> or timeout occurs brake is applied. Category 0 stop according to IEC 60204 (→ # 28).
2	Use controlled stop to disable drive, if the drive detects the motor to be at zero velocity <i>AXIS#.ZEROV</i> or timeout occurs brake is applied. Category 1 stop according to IEC 60204 (→ # 28).

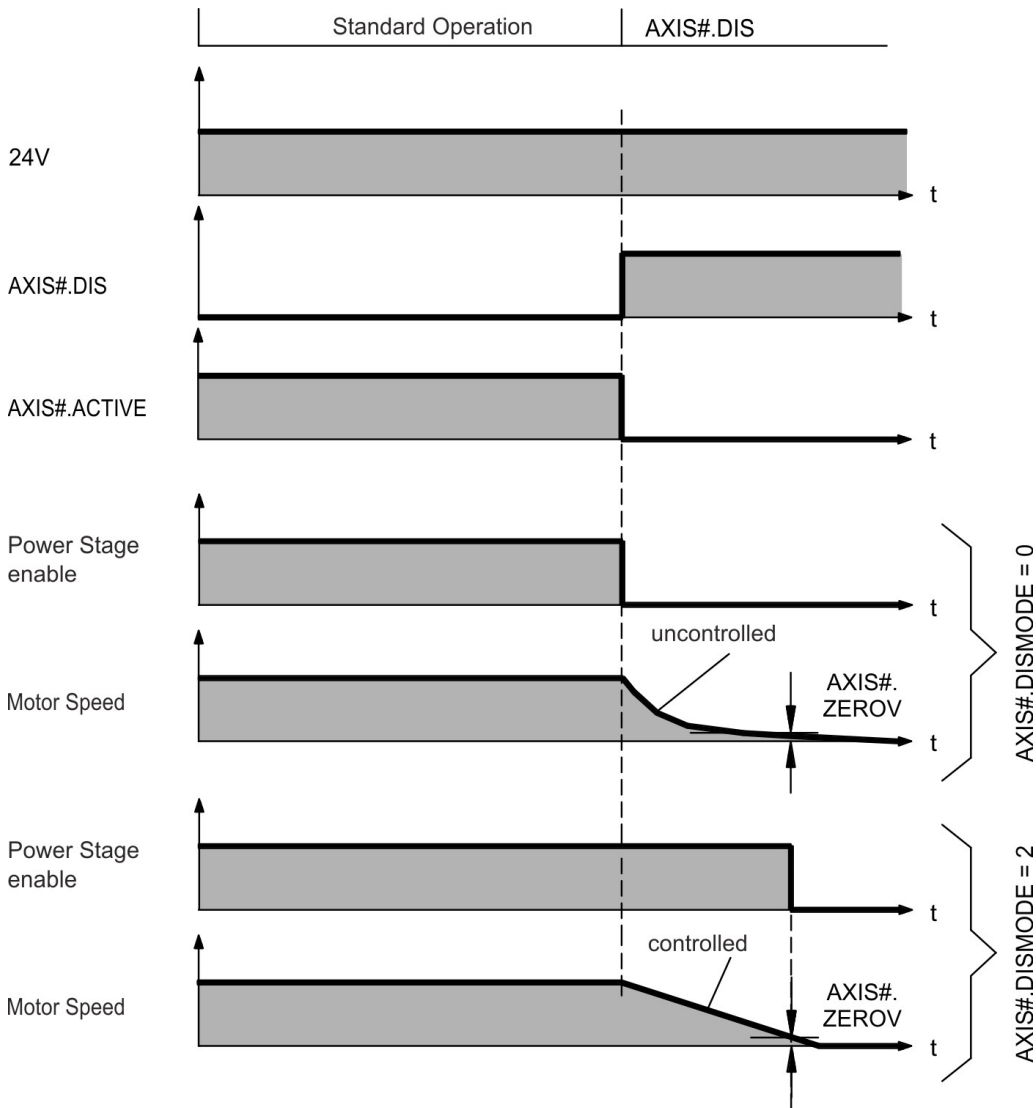

If the drive detects the motor to be at zero velocity (*AXIS#.ZEROV*) or timeout occurs (*AXIS#.ZEROT*), the motor brake is applied (→ # 113).

8.3.2.2 Switch-off behavior using a digital input (controlled stop)

This is a category 1 stop according to IEC 60204 (→ # 28).

A digital input can be configured to bring the motor to a controlled stop and then disable the drive and apply the holding brake (if present). See the *WorkBench Online Help* for information on configuring Digital Inputs.

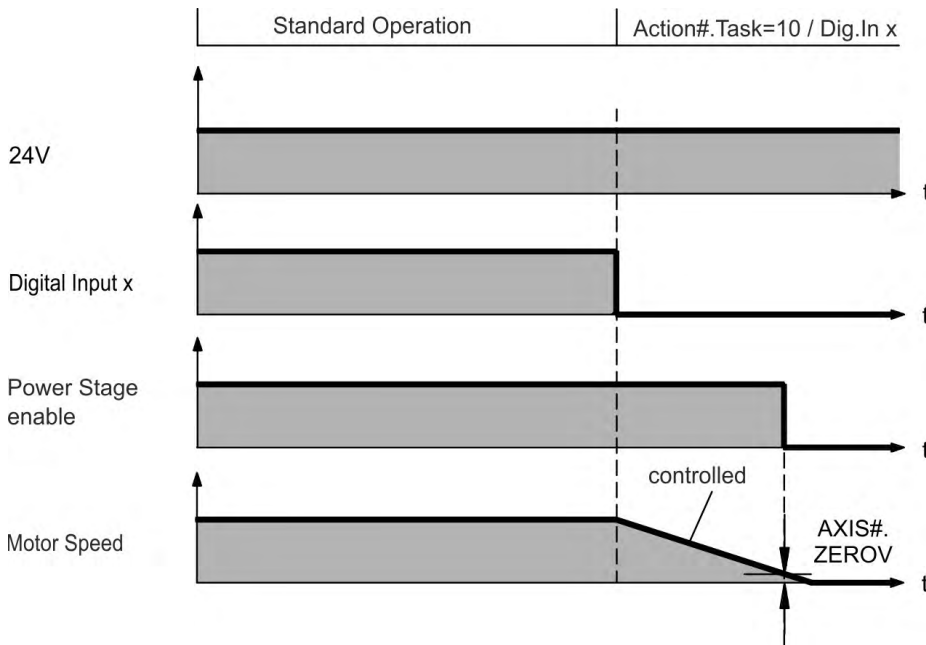

If the drive detects the motor to be at zero velocity (AXIS#.ZEROV) or timeout occurs (AXIS#.ZEROT), the motor brake is applied (→ # 113).

8.3.2.3 Switch-off behavior using STO input (uncontrolled stop)

This is a category 0 stop according to IEC 60204 (→ # 28).

The STO input disables the power stage immediately.

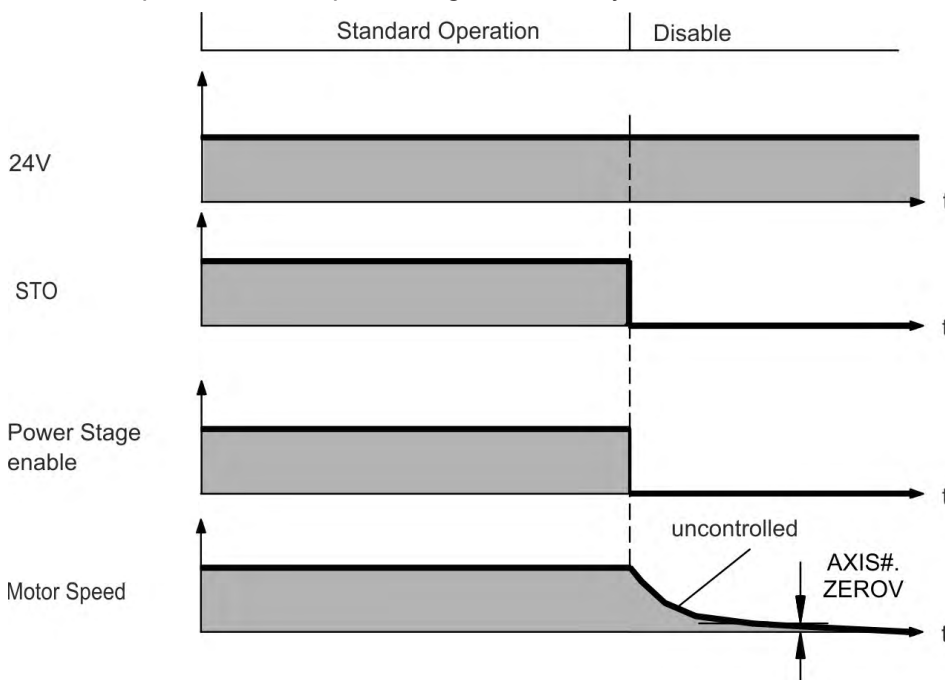

If the drive detects the motor to be at zero velocity (AXIS#.ZEROV) or timeout occurs (AXIS#.ZEROT), the motor brake is applied (→ # 113). Set parameter AXIS#.MOTOR. BRAKEIMM to 1 with vertical axes, to apply the motor holding brake immediately after STO.

8.3.2.4 Switch-off behavior in the event of a fault

The behavior of the drive always depends on the fault type and the setting of a number of different parameters (AXIS#.DISMODE, VBUS.UVFTHRESH, AXIS#.ZEROV, and others; see the *WorkBench Online Help* for more details). See the *Drive Fault and Warning Messages and Remedies* section of the *WorkBench User Manual* for a table describing the specific behavior of each fault. The next pages show examples for the possible fault behaviors. The fault relay output (DOUT9) switches the main contactor (Emergency Off circuit).

Switch-off behavior for faults that cause an immediate power stage disable

This is a category 0 stop according to IEC 60204 (→ # 28).

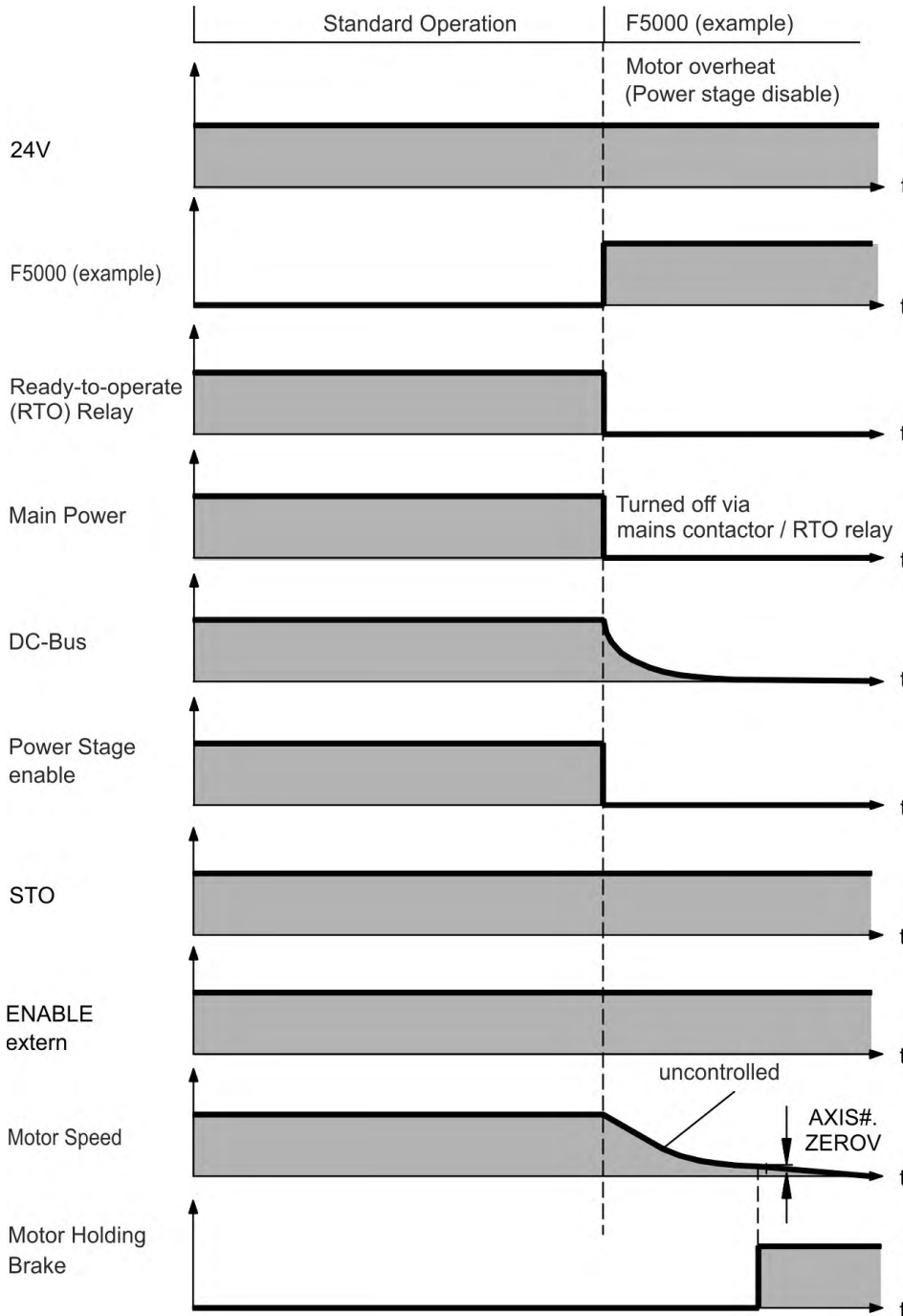

If the drive detects the motor to be at zero velocity (AXIS#.ZEROV) or timeout occurs (AXIS#.ZEROT), the motor brake is applied (→ # 113). Set parameter AXIS#.MOTOR.BRAKEIMM to 1 with vertical axes, to apply the motor holding brake immediately after faults.

Switch-off behavior for faults that cause dynamic braking

This is a category 2 stop according to IEC 60204 (→ # 28).

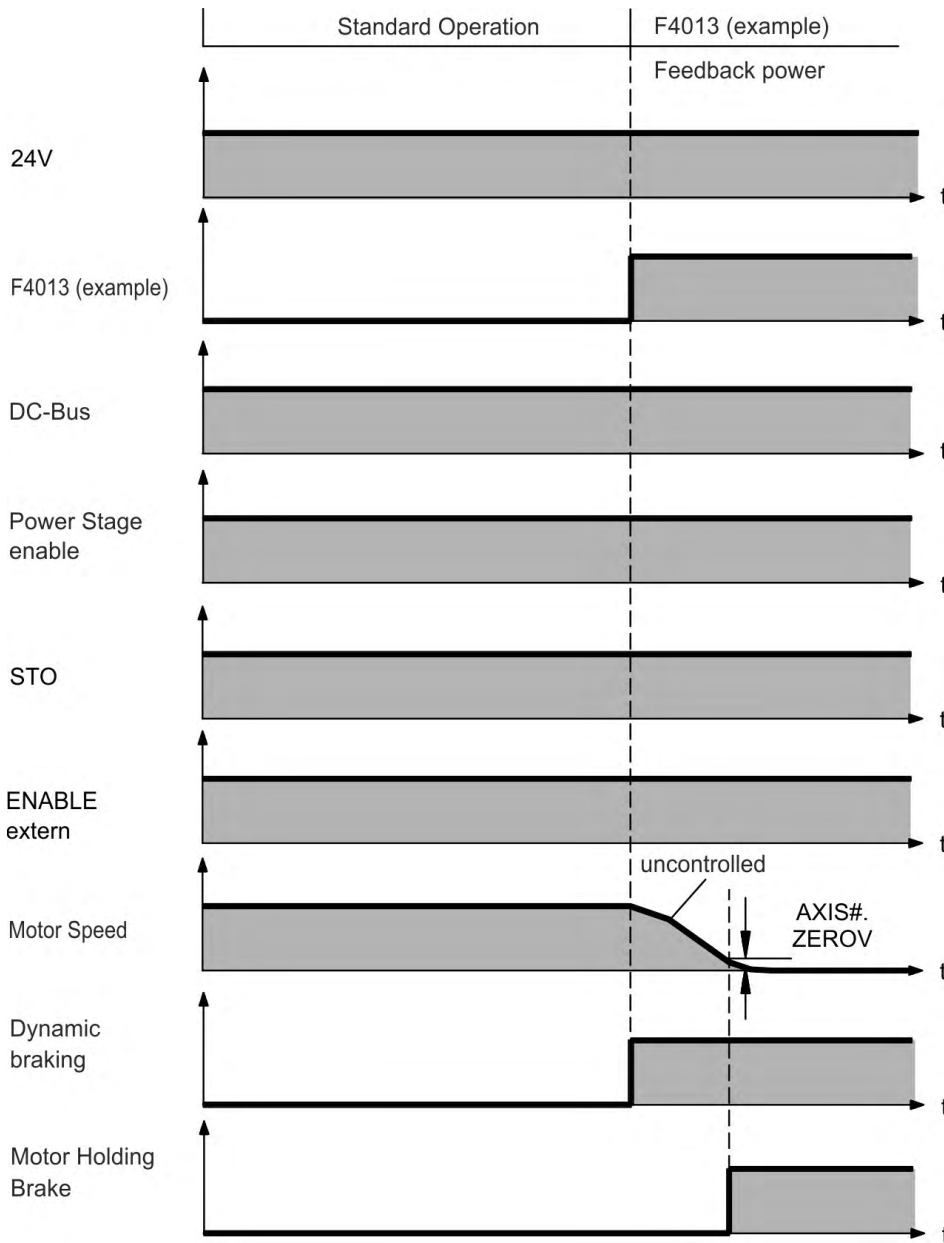

If the drive detects the motor to be at zero velocity (AXIS#.ZEROV) or timeout occurs (AXIS#.ZEROT), the motor brake is applied (→ # 113).

Switch-off behavior for faults that cause a controlled stop

This is a category 2 stop according to IEC 60204 (→ # 28).

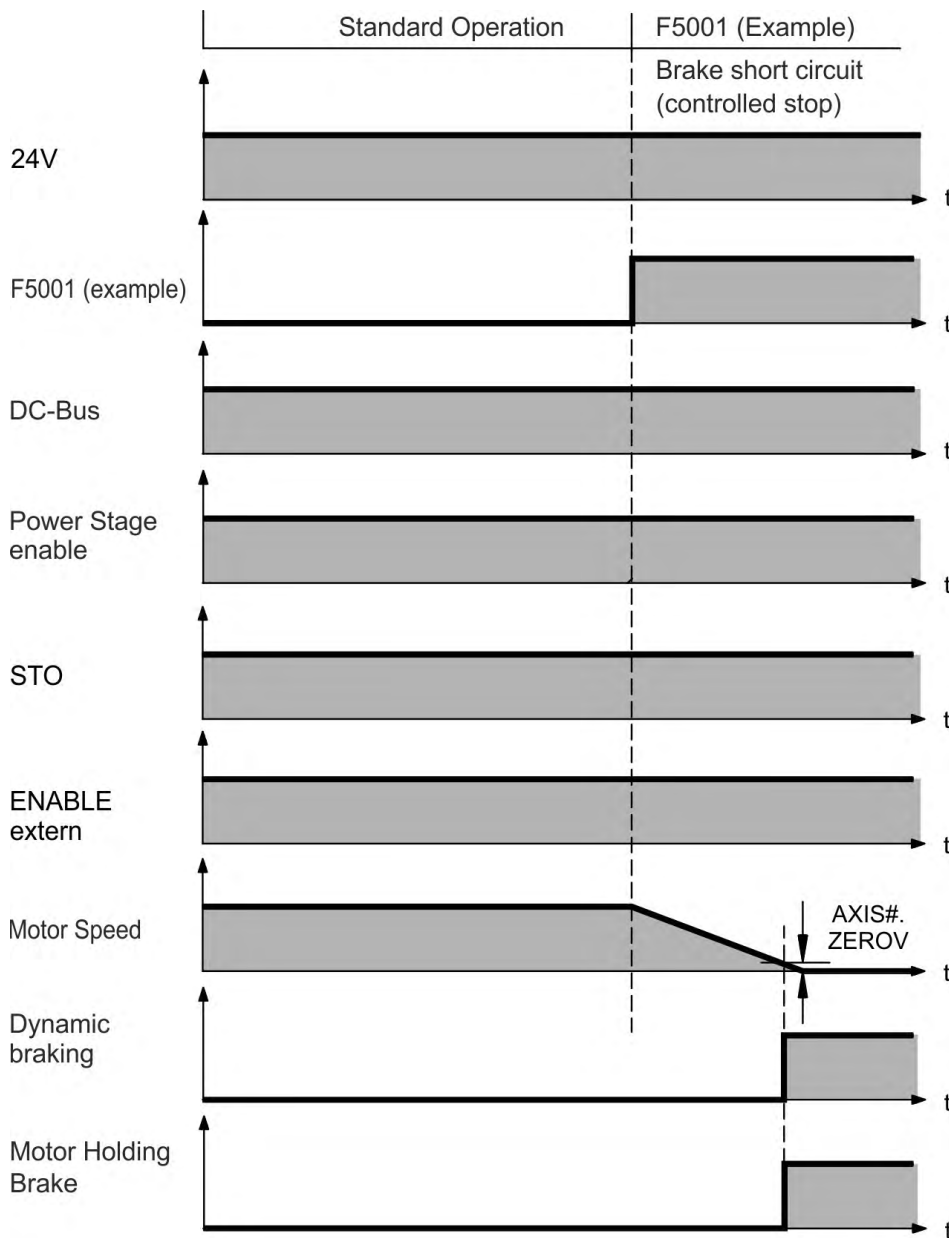

If the drive detects the motor to be at zero velocity (AXIS#.ZEROV) or timeout occurs (AXIS#.ZEROT), the motor brake is applied (→ # 113).

8.4 Fault and Warning Messages

8.4.1 Fault and warning messages AKD2G

A Fault is generally a notification of a critical system failure which will stop machine operation. Depending on the severity of the fault will depend on which system-stop mechanism is used.

A Warning is generally a notification to the user which is not critical and does not require the machine to immediately shut off.

Faults and Warnings follow the same pattern and are identified by a four digit code:

G G X X, where GG is a two digit group code, and XX is a two digit ID.

GG	Group	GG	Group
10	System	4#	Feedback (# indicates feedback number)
11	File	50	Motor
15	Hardware	55	Wake and Shake
20	Power	60	Motion
25	Temperature	70	Fieldbus
30	Software	90	Safety

The display on the front panel of the drive shows the code of the fault or warning that occurred. Navigate with B1 / B2 to the Fault screen to see a short description of the fault or warning.

Example: dual axes, Fault Axis 2

Example: single axis, Warning Axis 1

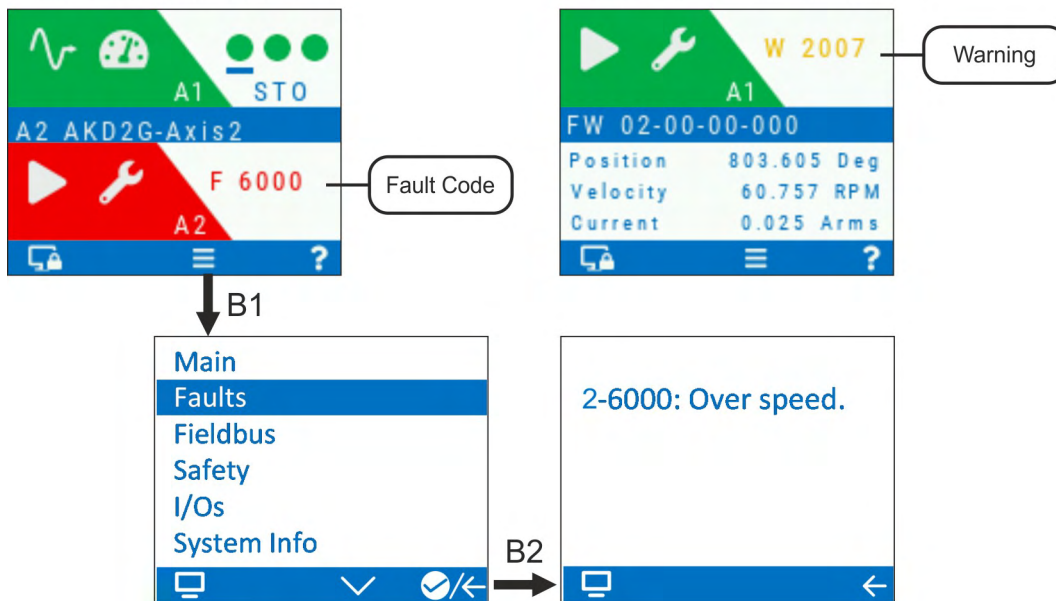

You can retrieve faults on a per-axis basis with the parameter: AXIS#.FAULTS, where # is the Axis number. For retrieving warnings use AXIS#.WARNINGS, or DRV.WARNINGS.

Multiple faults may be present when a fault condition is occurring. Check the WorkBench Fault Screen or read the status of DRV.FAULTS and AXIS#.FAULTS for the entire list of faults.

DRV.FAULTS will return all faults across all axes, with the format #-GGXX where # is the axis number and GGXX is the four digit fault/warning code.

NOTICE

Eliminate errors and faults in compliance with work safety rules. Troubleshooting only by qualified and trained staff.

NOTE

More information about fault messages, remedy and clearing faults can be found in the WorkBench User Manual.

8.5 Troubleshooting

Drive problems occur for a variety of reasons, depending on the conditions in your installation. The causes of faults in multi-axis systems can be especially complex. If you cannot resolve a fault or other issue using the troubleshooting guidance presented below, customer support can give you further assistance.

NOTICE

Eliminate errors and faults in compliance with work safety rules. Troubleshooting only by qualified and trained staff.

NOTE

More details on the removal of faults can be found in the WorkBench User Manual.

Problem	Possible Causes	Remedy
HMI message: Communication fault	<ol style="list-style-type: none"> wrong cable used, cable plugged into wrong position on drive or PC wrong PC interface selected 	<ol style="list-style-type: none"> plug cable into the correct sockets on the drive and PC select correct interface
Drive does not enable	<ol style="list-style-type: none"> HW Enable configured but not wired HW or SW Enable not set 	<ol style="list-style-type: none"> connect HW Enable to the selected input Apply 24V to HW Enable and select SW Enable in WorkBench / Fieldbus
Motor does not rotate	<ol style="list-style-type: none"> drive not enabled software enable not set break in setpoint cable motor phases swapped brake not released drive is mechanically blocked motor pole no. set incorrectly feedback set up incorrectly 	<ol style="list-style-type: none"> apply ENABLE signal set software enable check setpoint cable correct motor phase sequence check brake control check mechanics set motor pole no. set up feedback correctly
Motor oscillates	<ol style="list-style-type: none"> gain is too high (speed controller) feedback cable shielding broken AGND not wired up 	<ol style="list-style-type: none"> reduce AXIS#.VL.KP (speed controller) replace feedback cable join AGND to CNC-GND
Drive reports following error	<ol style="list-style-type: none"> I_{rms} or I_{peak} set too low current or velocity limits apply accel/decel ramp is too long 	<ol style="list-style-type: none"> verify motor/drive sizing verify that AXIS#.IL.LIMITN/P, AXIS#.VL.LIMITN/P are not limiting the drive reduce AXIS#.ACC/AXIS#.DEC
Motor overheating	<ol style="list-style-type: none"> motor operating above its rating motor current settings incorrect 	<ol style="list-style-type: none"> verify motor/drive sizing verify motor continuous and peak current values are set correctly
Drive too soft	<ol style="list-style-type: none"> AXIS#.VL.Kp (velocity) too low AXIS#.VL.Ki (velocity) too low filters set too high 	<ol style="list-style-type: none"> increase AXIS#.VL.KP (velocity) increase AXIS#.VL.KI (velocity) refer to documentation regarding reducing filtering (AXIS#.VL.AR*)
Drive runs roughly	<ol style="list-style-type: none"> AXIS#.VL.Kp (velocity) too high AXIS#.VL.Ki (velocity) too high filters set too low 	<ol style="list-style-type: none"> reduce AXIS#.VL.KP (velocity) reduce AXIS#.VL.KI (velocity) refer to documentation regarding increasing filtering (AXIS#.VL.AR*)

9 Safety Manual for FS3

Revision History for Safety Manual

Revision	Remarks
S301, 05/2021	Functional Safety Option 3
S302, 07/2022 (withdrawal)	some limitations solved with new SMM FW 1.12, diagrams edited for SS2, SS1-r, SLS and SSR, new SDB timing and state machine diagram, new chapter "Update the SMM firmware", commissioning chapter: no mapping for switching state (bulletpoint removed), chapter recommissioning: layout modified, chapter safety properties overview: ISO->IEC, table "activation by FSoE" modified, table "dual channel activation" and "single channel activation" modified, dual channel graphic changed, t3 added to "encoder position change" table, chapter save digital inputs revised, changes in chapter motor brake requirements and motor feedback requirements, all safety function chapters revised, settings chapter revised, validation and operation chapters revised, chapter safety faults/safety warnings revised
S303, 03/2023	Hardware Revision table edited, note added under SS1-t and SS1-r timing diagram, limitation table edited, SDB timing diagram changed, add FW 02-10-00-103
S304, 03/2024	Added a note at the end of 10.4.1.4 Safety Function Response Time Calculation regarding a possible safe encoder internal fault, updated Safety Manual version compatibility table.
S305, 10/2024 (INTERNAL)	Chapter "versions" removed from SAFEPARAM.ENCODERHDSLTYPE1 parameter, SMM2 content added: default values for parameters changed, parameter range changed, paragraph removed ("AXIS#.SAFEPARAM.SBT.MAXMOTIONBRAKE#"), encoder source removed, t_SDB removed and frozen to 6ms, AXIS#.SAFEPARAM.SDB.DELAYBEFOREDIAGNOSE removed, SAFEPARAM.ENCODERENDATTYPE removed, SAFEPARAM.ENCODERHDSLTYPE1 updated, SAFEPARAM.HDSLCHAN1SINGLETURNRES1 new, SAFEPARAM.ENCODERHDSLTYPE2 updated, SAFEPARAM.HDSLCHAN1SINGLETURNRES2 new, SAFE.ERROR updated, table "Safety Function Response Time Calculation" updated, description for SS2 added, descriptions in Operation States table changed, SAR timing diagram corrected, SOS state diagram changed
S306, 02/2025	Chapter "versions" removed from SAFEPARAM.ENCODERHDSLTYPE1 parameter, SMM2 content added: default values for parameters changed, parameter range changed, paragraph removed ("AXIS#.SAFEPARAM.SBT.MAXMOTIONBRAKE#"), encoder source removed, t_SDB removed and frozen to 6ms, AXIS#.SAFEPARAM.SDB.DELAYBEFOREDIAGNOSE removed, SAFEPARAM.ENCODERENDATTYPE removed, SAFEPARAM.ENCODERHDSLTYPE1 updated, SAFEPARAM.HDSLCHAN1SINGLETURNRES1 new, SAFEPARAM.ENCODERHDSLTYPE2 updated, SAFEPARAM.HDSLCHAN1SINGLETURNRES2 new, SAFE.ERROR updated, table "Safety Function Response Time Calculation" updated, description for SS2 added, descriptions in Operation States table changed, SAR timing diagram corrected, SOS state diagram changed

The Safety Manual is valid for:

AKD2G with Functional Safety Option 3 (FS3):

AKD2G - xxx - xxxxx - x3xx - xxxx

Integrated **SafeMotion Monitor (SMM)**, activation by digital I/O or FSoE

Extended Safety Functions: STO, SS1-t, SS1-r, SS2, SOS, SLS, SSM, SSR, SDI, SLA, SAR, SLI, SLP, SCA, SBC, SDB, SBT; SIL3 PLe

Hardware Revision	Drive Firmware	WorkBench	SMM Firmware	Comment
A	02-12-00-105	2.15.0.10823	R_02-07-000	

Note: Previously listed combinations remain valid.

SMM Firmware Version 1.12 has been withdrawn.

Refer to the list of limited safety features (Limitations, → # 553).

Contents:

9.1 General Notes	195
9.2 Updating the SMM Firmware	199
9.3 Commissioning	201
9.4 Safety Functions Option 3 (FSoE, SIL3 PLe)	203
9.5 Settings	288
9.6 Validation	307
9.7 Operation	309
9.8 Safety Faults, Safety Warnings	311
9.9 Functional Safety Parameter Reference	315

9.1 General Notes

Resulting Functional Safety classification (SIL and/or PL level) is calculated across the drive system. The drive system usually consists of the following:

- motion controller (e.g. AKC/KAS),
- safety controller (e.g. KSM),
- servo drives (AKD2G) and servo motors (e.g. AKM2G),
- motor brakes, feedback systems,
- cables to connect drive and motor,
- sensors/actors

The safety properties listed in this chapter can be reached with Kollmorgen components.

NOTICE

The user must ensure the compliance of the application with all relevant directives and local electrical code. The user is responsible for implementation and validation of the drive system and safety system. Only properly qualified personnel are permitted to perform installation, setup and verification/validation tasks.

- Mechanical installation: only by qualified personnel with mechanical expertise according to IEC 60417-6183.
- Electrical installation: only by qualified personnel with electrotechnical expertise according to IEC 60417-6182.
- Parameterizing Functional Safety: only by trained personnel with expertise appropriate to the complexity and safety integrity level of the drive system.
- Verification/Validation: only by trained personnel after any changes to the installation. The expertise of the personnel must be appropriate to the complexity and safety integrity level of the drive system.

NOTE

- Safe State:** In a safe state the drive removes the motor torque is removed from all axes, applies the brake(s), deactivates all of the safe digital outputs, and sets the safe fieldbus connection to the safe state (if applicable).
- Trigger conditions:** I/O failure and internal failure (such as problems detected on the drive or on the safety system itself) lead to safe state.



CAUTION High electrical voltage!

Risk of electrical shock! The safety functions do not provide an electrical separation from the power output. If manual access to the motor or drive power terminals is necessary,

- disconnect the drive from mains supply,
- consider the discharging time of the DC-Bus link,
- ensure the cabinet is safely disconnected and protected against unintended switch-on (for instance, with a lock-out and warning signs).



WARNING Projection of molten particles!

If particles fall into the drive or the drive has been damaged, molten drive component particles may be ejected causing injuries. Shut down the drive and wear appropriate protective gear during maintenance work, troubleshooting and fault rectification. (→ # 34)

9.1.1 Use as directed

Safety functions are intended to reduce the risk of the machine operation to the required tolerable risk. To achieve functional safety, the wiring of the safety circuits must meet the safety requirements of IEC 60204, ISO 12100 and ISO 13849.

NOTICE

- The network the drive is connected to must be secured according to state-of-the-art information technology security requirements.
- The IT specialists shall analyze whether further security requirements are applicable to ensure functional safety.
- The drive firmware can be updated. The parameter sets must be reloaded, verified and proof tested before normal operation is started.
- The SafeMotion Monitor (SMM) firmware can be updated by the user, see (→ # 199). For training and certification please contact Kollmorgen. The safety parameter set must be reloaded, verified and proof tested before normal operation is started.
- In certain types of machinery, two motors drive a single mechanical axis. It is the responsibility of the user to ensure that a fault reaction on the first motor-drive set is also carried out on the second motor-drive set and vice versa. Safe I/O and/or a safe fieldbus such as FSoE can be used to achieve this.

9.1.2 Prohibited use

The safety functions must not be used if the drive is to be made inactive for Emergency-Off situations. In an Emergency-Off situation, the main relay is switched off by the Emergency-Off button.

The device does not require maintenance. Opening the device voids the warranty. In case of damage or malfunction, the drive must be sent for repair or replacement if it cannot be repaired.

NOTICE

The drive may not be connected directly to the Internet. It could be a functional safety risk if the network the drive is connected to is not secured according to state-of-the-art information technology. The SafeMotion Monitor (SMM) does not fulfill requirements regarding the IEC 62443.

9.1.3 Abbreviations used for functional safety

More abbreviations see (→ # 21).

Abbreviation	Meaning
A#, AXIS#	A# or AXIS# are placeholders for the axis number. Used with parameters (AXIS#.SAFE.STO.ACTIVE) or signal names (STO-A-A#)
(→ # 53)	"see page 53" in this document
→ xyz	"see chapter xyz" in this document
CCF	Common Cause Failure
CRC	Cyclic Redundancy Check
DGUV	Deutsche Gesetzliche Unfallversicherung
FS3	Functional Safety Option 3 (Safe Stop and Safe Motion functions)
FSoE	Fail Safe over EtherCAT
HFT	Hardware Fault Tolerance
MTTFd	Mean time to dangerous failure
OSSD	Output Switching Signal Device
PELV	Protective Extra Low Voltage
PFH	Probability of dangerous failure per hour
PL	Performance Level
SAR	Safe Acceleration Range
SBC	Safe Brake Control
SBT	Safe Brake Test
SC	Systematic Capability
SCA	Safe Cam
SDB	Safety Dynamic Break
SDI	Safe Direction
SFF	Safe Failure Fraction
SIL	Safety Integrity Level
SLA	Safely Limited Acceleration
SLI	Safely Limited Increment
SLP	Safely Limited Position
SLS	Safely Limited Speed
SMM	SafeMotion Monitor
SRA CRC	Safety-Related Application CRC
SS1	Safe Stop 1
SS1-t	Safe Stop 1 time based
SS1-r	Safe Stop 1 deceleration monitoring
SS2	Safe Stop 2
SSM	Safe Speed Monitor
SSR	Safe Speed Range
STO	Safe Torque Off
TM	Mission Time

9.1.4 Enclosure, wiring

Enclosure

Since the drive meets IP20, you must select an enclosure that permits safe operation of the drive. The enclosure must at least meet IP54 .

Transport in accordance with IEC 61800-2	
NOTE	Transport only in the manufacturer's original recyclable packaging.
Temperature	-25 to +70 °C, maximum rate of change 20 K/hour, class 2K3.
Relative Humidity	max. 95% at +40 °C, no condensation, class 2K3.
Shock	NOTICE: Avoid shocks while transporting. AKD2G modules are tested for environmental class 2M1 of IEC 60721-3-2.
Storage in accordance with IEC 61800-2	
Temperature	-25 to +55 °C, maximum rate of change 20 K/hour, class 1K4.
Relative Humidity	5 to 95% , no condensation, class 1K3.
Operation in accordance with IEC 61800-2	
Environmental Class	Environmental class 3K3
Temperature	Internal regen resistor used: <ul style="list-style-type: none"> • 0 to +40 °C under rated conditions • +40 to +60 °C with current derating 3 % per Kelvin Internal regen resistor not used: <ul style="list-style-type: none"> • 0 to +50 °C under rated conditions • +50 to +60 °C with current derating 2% per Kelvin
Relative Humidity	5 to 85%, no condensation, IEC 61800-2 class 3K3
Site Altitude	<ul style="list-style-type: none"> • Up to 1000 m above mean sea level (AMSL): no restriction • 1,000 to 2,000 m AMSL: power derating 1.5%/100 m • Maximum altitude: 2000 m AMSL
Drive EMC Immunity	Increased immunity according to EN 61800-5-2
Drive Pollution Level	Pollution level 2 as per IEC 60664-1
Drive Vibration Class	Class 3M1 according to IEC 61800-2
Drive Shock Class	Class L according to IEC 61800-2
Drive Protection Class	IP20 according to IEC 60529
Enclosure	Minimum cabinet size (WxHxD): 406 x 406 x 254 mm
Enclosure Protection	At least IP 54 according to IEC 60529

Wiring

Wiring inside the specified enclosure (IP54) must meet the requirements of the standard IEC 60204-1 and ISO 13849-2 (Table D.4). Use copper wires, 0.5 mm² (20 awg), wire ferrules. Maximum distance for unshielded I/O lines is 3 m inside the cabinet. If the I/O cable leaves the cabinet, it must be EMC shielded.

Wiring outside the specified enclosure must be laid durably protected from outside damage (for example, by laying the cable in a duct, placed in different sheathed cables, or protected individually by grounding connection).

NOTICE

When wiring the digital inputs and outputs, take care that short circuits between the inputs, outputs, or to supply lines are avoided.

9.2 Updating the SMM Firmware

Before updating the SMM firmware, please read the following information carefully:

NOTICE

- Replace certified SMM firmware only with another certified SMM firmware, see (→ # 193).
- Changing the SMM firmware means changing the drive firmware, its ESI file and the WorkBench version. Only use a consistent firmware package. For information on compatibility see (→ # 193).
- Only trained and qualified personnel shall update the SMM firmware.
- Safety parameters will be removed and need to be re-validated.

To perform the update, you need the following:

- Kollmorgen WorkBench with a safety project
- update password
- SMM firmware binary file
- checksum of the new firmware (sometimes called the CRC in firmware release notes)

Follow these steps to update the SMM firmware on one or more drives:

1. Navigate to the **Safety** tab and select the drive(s) you want to update in the WorkBench view.
Note: Make sure the axes are disabled before you update the firmware.
2. Select the **Update** button.

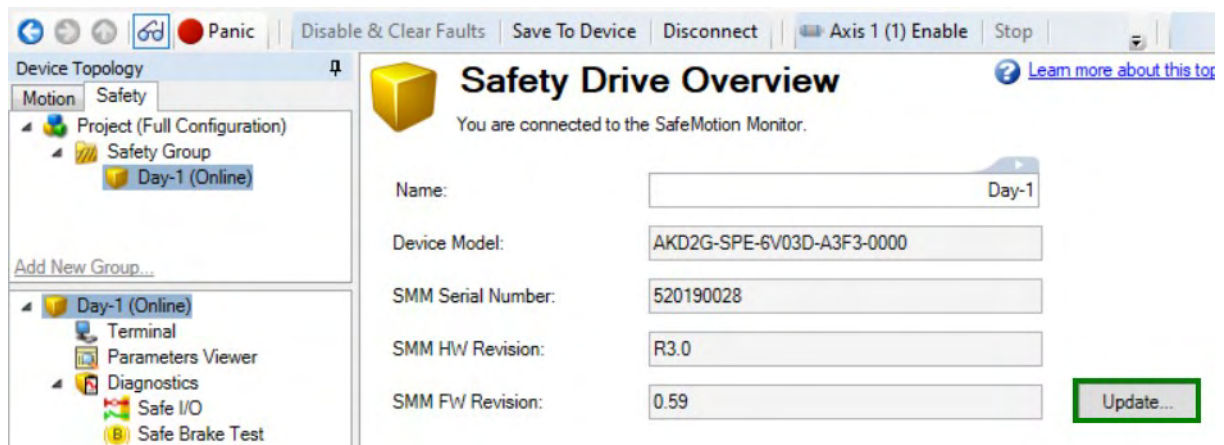

3. The **Safety Firmware Update** view will appear. Select the drive(s) and fill in the required information: the update password, firmware checksum, and firmware file.

4. Make sure the current Firmware Version (FW Ver.) is correct.

Select	Name	Model	Connected	SafelD	Update Allowed	HW Rev.	FW Ver.	Status	Ident	Action
<input checked="" type="checkbox"/>	Day-1	AKD2G-SPE-6V03D-A3F3-0000	<input checked="" type="checkbox"/>	01	<input checked="" type="checkbox"/>	R3.0	0.59			Blink

Connect All Disable All

Update SafeMotion Monitor Firmware File

User Name: Password:

Firmware Checksum: Hexadecimal values should be prefixed by 0x

Firmware File:

1 Device(s) Selected

5. Select the **Update** button.

Note: If the current SMM version and the targeted version are not compatible, a warning message will say that the safety parameters will be lost.

6. Ensure that the new firmware version is correct.

9.3 Commissioning

NOTICE

The safety features of the AKD2G only fulfill their purpose and can only function properly when the machine was developed according to ISO 12100, ISO 13849 and EN 62061. Depending on the use case, further standards may apply.

The machine manufacturer is responsible for proper and safe commissioning. Violating the applicable standards can result in potential unsafe conditions or dangerous machine behavior. Only properly qualified and trained personnel are permitted to perform the following tasks.

9.3.1 First time commissioning

Situation	Action
Before commissioning	<ul style="list-style-type: none"> • A risk assessment must be carried out, covering all risks originating from the machine. • Safety functions for risk reduction require sufficient definition such as functionality, PLr / SIL, reaction times, etc. Analyze your machine accordingly. • The safety functions must be specified: components, SIL/PL, PFH, category, TM, CCF measures for tests like SBT, MTTFd, DC, combinations of functions, etc.. • Take precautionary measures against foreseeable misuse or manipulation which result in bypassing the safety functions. • Calculate and analyze whether the specified safety chain is sufficient to reach the required PLr / SIL. • Set up a commissioning plan that specifies all actions of the verification and validation. • Take quality assurance measures for all steps such as: reviews, FMEAs, independent and qualified personnel, and four-eyes principle.
During commissioning	<ul style="list-style-type: none"> • Verify that the hardware configuration is set up as specified (components, architecture, wiring, CCF measures, etc.). • Verify that the software configuration is done according to the specification. Suitable measures can be: reviews, black-box tests, simulations, and function tests. Make sure that only the required functions are configured. • Make sure that the safety functions are executed as expected and that the configuration is suitable for the application. Suitable measures are function tests and fault injection tests (error condition tests). • Validate the machine (→ # 307) Test the final product with all safety functions and in all operation modes and states. • Validate that the safety functions do not interfere with each other or other functions in an undesired way. If used, check if all instances are assigned to the right use cases. Pay special attention to the correct use of safety function muting. • Make sure that all safety functions and all possible situations are covered by the validation process. • Document all actions and decisions according to the requirements of the standards (→ # 308).
After commissioning	<ul style="list-style-type: none"> • Document and validate all information relevant to the end user in a suitable way. This includes the capabilities and limitations of the safety functions as well as maintenance instructions. • Change default passwords and store them somewhere inaccessible to unqualified or unauthorized personnel. Protect the hardware from unwanted or unauthorized modifications.

For detailed information refer to the applicable standards.

9.3.2 Recommissioning

Situation	Action
After disassembling, reassembling or drive replacement (Field Replacement, → # 310)	<ul style="list-style-type: none"> • Verify the correct reassembling according to the original specification. • Verify that the correct safe parameter package was uploaded to the correct drive. • Check all components and wiring for correct installation and for signs of damage. • Carry out function tests and fault injection tests again. • Validate all functions and combinations of functions again.
After long standstill	<ul style="list-style-type: none"> • Check all components for their TM and signs of damage or unacceptable wear. Components that have exceeded their TM or show signs of damage need to be replaced.
After modification	<ul style="list-style-type: none"> • Reevaluate and revalidate the safety functions according to (First time commissioning, → # 201) • Alternatively: Set up a modification process by carrying out an analysis to identify all possible influences on safety. Reverify the affected aspects and revalidate the machine. • Update your documentation and end user information accordingly.

NOTICE

Modifying safety functions could void certifications and approvals from notified bodies. Contact your notified body for further information.

Only properly qualified and trained personnel is permitted to perform these tasks.

9.3.3 Diagnostic Testing of safe inputs, safe outputs and STO

Safe inputs require test pulses (OSSD, → # 212) and there is no further requirement for diagnostic testing of the input wiring. There may however be additional diagnostic requirements for the device connected to the safe input.

STO is continuously diagnosed internally. There is no further requirement for diagnostic testing.

9.3.4 Diagnostic Testing of safe brake control

The BRAKE+ and BRAKE- emit test pulses (→ # 241). There is no further requirement for diagnostic testing of the brake wiring. Depending on the target SIL/PL, there is a periodic requirement to test the brake itself, see documentation on SBC (Safe Brake Control) (→ # 240) and SBT (Safe Brake Test) (→ # 249).

9.4 Safety Functions Option 3 (FSoE, SIL3 PLe)

The safety functions on the AKD2G with functional safety option 3 are certified.

NOTICE

The drive is ready to operate with a pre-configured STO function.

Each safety function can either be activated through FSoE, digital input, both. Configure the source of activation inside the safety parameters so it matches the system requirements.

Review the default setting and check if it matches the requirements. If it does not match, modify and validate the safety parameters.

For Digital I/O commanding, use WorkBench to map safety functions to Safe I/Os.

With [FSoE](#) the safety functions can be activated with the safePLC of the FSoE Master.

With dual axis drives every safety function can be activated for either one axis or for both axes (axis 1 or axis 2 or axes 1 and 2).

NOTE

The systematic safety integrity indicated by the systematic capability can be achieved only when the instructions and constraints are observed. Where violations occur, the claim for systematic capability is partially or wholly invalid.

Standards

Standard	Content
ISO 13849:2024	Safety of machinery: Safety-related parts of control systems

Available Safety Functions

Activation and reachable Performance level / Category (→ # 204).

Abbr.	Function	Category	Refer to
STO	Safe Torque Off	Safe Stop	(→ # 219)
SS1-t	Safe Stop 1, time based	Safe Stop	(→ # 223)
SS1-r	Safe Stop 1, deceleration monitoring	Safe Stop	(→ # 228)
SS2	Safe Stop 2	Safe Stop	(→ # 232)
SOS	Safe Operating Stop	Safe Stop	(→ # 236)
SBC	Safe Brake Control	Safe Stop	(→ # 240)
SBT	Safe Brake Test	Safe Stop	(→ # 249)
SDB	Safe Dynamic Brake	Safe Stop	(→ # 255)
SLS	Safely Limited Speed	Safe Speed	(→ # 261)
SSM	Safe Speed Monitor	Safe Speed	(→ # 264)
SSR	Safe Speed Range	Safe Speed	(→ # 266)
SDI	Safe Direction	Safe Speed	(→ # 269)
SLA	Safely Limited Acceleration	Safe Speed	(→ # 273)
SAR	Safe Acceleration Range	Safe Speed	(→ # 276)
SLI	Safely Limited Increment	Safe Position	(→ # 280)
SLP	Safely Limited Position	Safe Position	(→ # 283)
SCA	Safe Cam	Safe Position	(→ # 286)

Rotary switches S1/S2 and push-buttons B1/B2

Switches and buttons on the device front (→ # 289) are used to set the SafeID (→ # 289).

9.4.1 Safety Properties Overview

General properties	Values
Hardware fault tolerance (IEC 61508)	HFT = 1

General properties	Values
Classification element (IEC 61508)	Type B subsystem
Systematic capability	SC = 3
Mission time	TM = 20 Years
Proof test interval	> 20 Years
Safe failure fraction	SFF = 99%
PFH fraction of SIL 3	1.7%
Probability of dangerous failure per hour	$PFH_d = 1.7E-09$ 1/h
Mean time to dangerous failure	$MTTF_D = 55.6$ Years
Diagnostic coverage	$DC_{AVG} = 99.6\%$
Common cause failure (see annex F of ISO 13849-1)	CCF: score = 75

Calculation example for safety chain PFH_d :

- Safety PLC that is the FSoE master.
- EtherCAT cabling etc.
- Two drives configured for STO activation over FSoE.

Contribution to the safety chain of the safety PLC: PFH_{PLC} refer to manufacturer data.
 Contribution to the safety chain of using FSoE via EtherCAT cabling etc. is $1.0E-9$ 1/h.
 Contribution to the safety chain of the two drives PFH_d is $2 \times 1.7E-9$ 1/h.
 Total value: $PFH_d = PFH_{PLC} + 2 \times 1.7E-9$ 1/h + $1.0E-9$ 1/h = $PFH_{PLC} + 4.4E-9$ 1/h

9.4.1.1 Activation by FSoE

Safety Function	ISO 13849-1	IEC 62061 (IEC 61508)	Maximum Response Time	Comment
STO	PLe, Cat.4	SIL3	< 10 ms	
SS1-t	PLe, Cat.4	SIL3	< 10 ms	followed by STO*
SS1-r	PLe, Cat.4, SIL3 or PLd, Cat.3, SIL2 (limited by the safe encoder)		< 10 ms	followed by STO*
SS2				followed by SOS
SOS, SSM, SSR, SCA, SDI, SLA, SLI, SLP, SLS, SAR				

* = configured delay (time to STO) see "AXIS#.SAFEPARAM.SS1_#.TIMETOSTO" (→ # 464).

9.4.1.2 Activation by Safety Functions

Safety Function	ISO 13849-1	IEC 62061 (IEC 61508)	Maximum Response Time	Comment
SBC with one brake	PLd, Cat.3	SIL2	< 10 ms	Needs to be configured for activation during STO process
SBC with two brakes	PLe, Cat.4	SIL3	< 10 ms	
SDB single channel	PLd, Cat.3	SIL2	< 10 ms	
SDB dual channel	PLe, Cat.4	SIL3	< 10 ms	

9.4.1.3 Activation By Safe Digital Inputs

NOTICE

When activated by using safe digital inputs, a safety device with test pulses is required (OSSD, (→ # 212)).

Safe inputs must be driven from a source containing test pulses, this can be a safe digital output or a safety device with suitable outputs. If the SMM is configured to detect distinct test pulses, then no fault exclusion is required against wiring shorts and cross-talk.

Electromechanical devices such as relays and emergency stop switches can be wired in series with a source of test pulses; the B10d value of the mechanical contacts may limit the achievable safety level.

Safety Level	Single Safe Input	Dual Safe Inputs
SIL2, PLd Cat. 3	✓	✓
SIL3, PLe Cat. 4	—	✓

Safety functions that monitor motion require a safe encoder. The safety properties of the safe encoder may limit the achievable safety level.

Dual Channel Activation

Safety Function	ISO 13849-1	IEC 62061 (IEC 61508)	Maximum Response Time	Comment
STO	PLe, Cat.4	SIL 3	< 10 ms	
SS1-t	PLe, Cat.4	SIL 3	< 10 ms	followed by STO*
SS1-r	PLe, Cat.4, SIL 3 or PLd, Cat.3, SIL 2 (limited by the safe encoder)		< 10 ms	followed by STO*
SS2				followed by SOS
SOS, SSM, SSR, SCA, SDI, SLA, SLI, SLP, SLS, SAR				

* = configured delay (time to STO) see [AXIS#.SAFEPARAM.SS1_#.TIMETOSTO](#)

Dual channel for axis1 and axis2, Safety Control with electronic outputs, automatic restart:

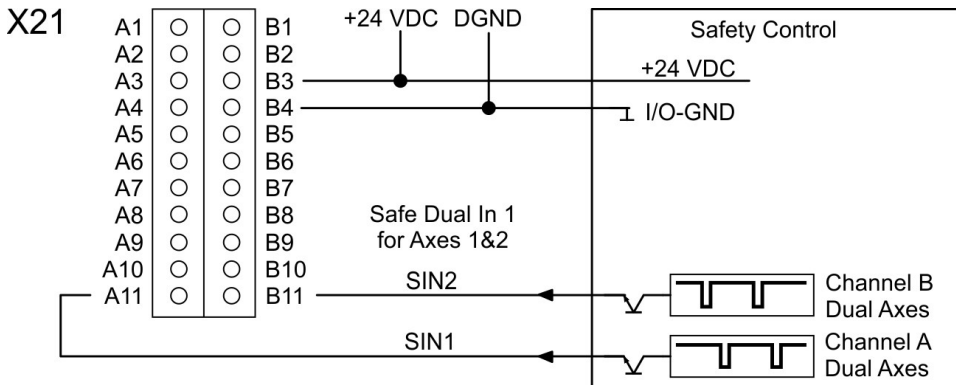

Dual channel for axis1 and axis2, Safety Control with relay contacts, automatic restart:

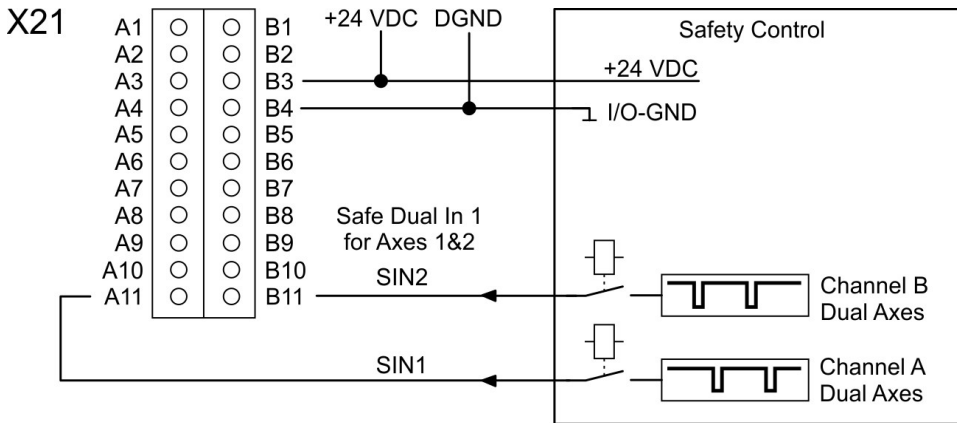

Dual channel for axis1 and axis2, Emergency Stop, automatic restart (example for default configuration):

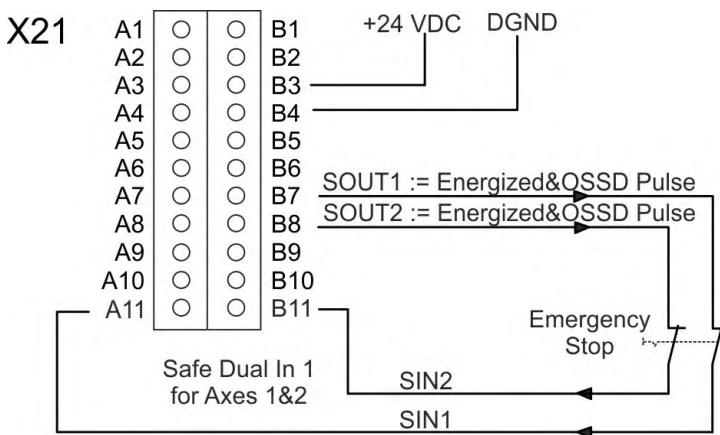

Dual channel for axis1 and axis2, Emergency Stop, manual restart:

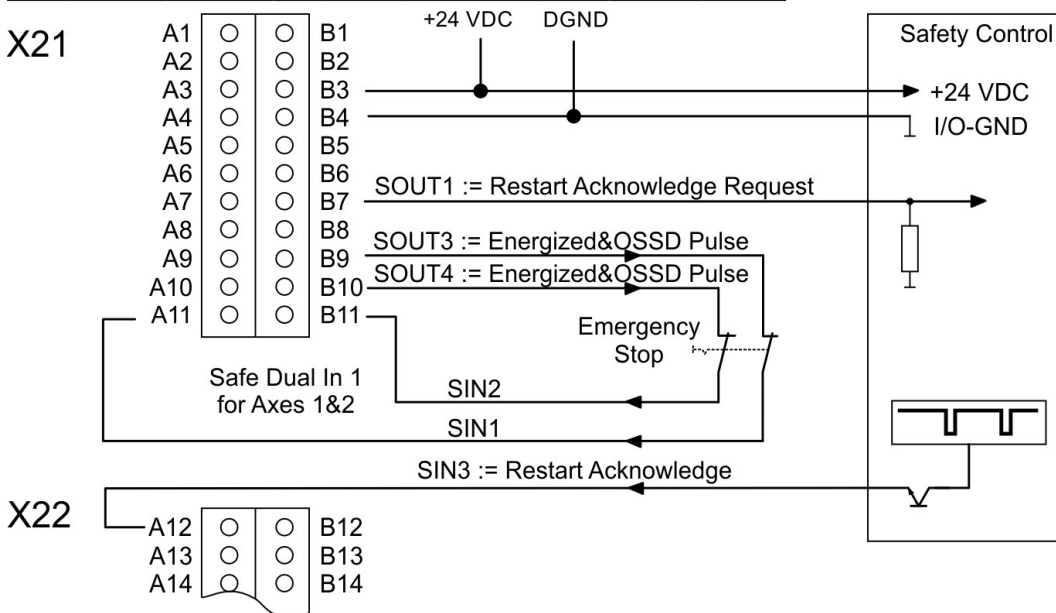

Single Channel Activation

Safety Function	ISO 13849-1	IEC 62061 (IEC 61508)	Maximum Response Time	Comment
STO	PLd, Cat.3	SIL 2	< 10 ms	
SS1-t	PLd, Cat.3	SIL 2	< 10 ms	followed by STO*
SS1-r	PLd, Cat.3	SIL 2	< 10 ms	followed by STO*
SS2	PLd, Cat.3	SIL 2	< 10 ms	followed by SOS
SOS, SSM, SSR, SCA, SDI, SLA, SLI, SLP, SLS, SAR	PLd, Cat.3	SIL 2	< 10 ms	

* = configured delay (time to STO) see [AXIS#.SAFEPARAM.SS1_#.TIMETOSTO](#)

Single channel for axis1 and axis2, Safety Control with electronic outputs, automatic restart:

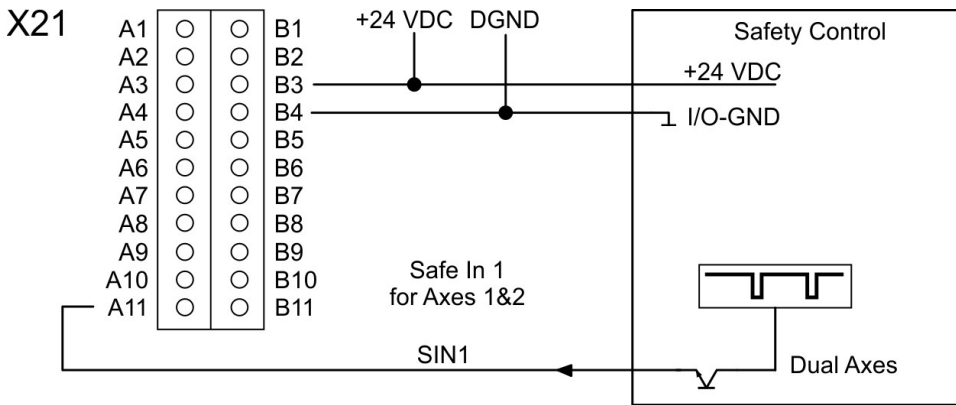

Single channel, 2 axes, Safety Control with relay contacts, automatic restart (distinct pulse monitoring must be disabled):

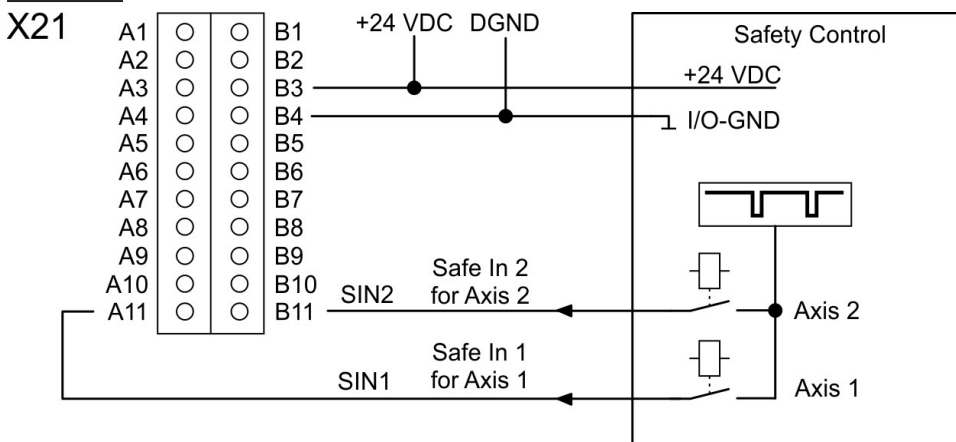

Single channel for axis1 and axis2, Emergency Stop, automatic restart:

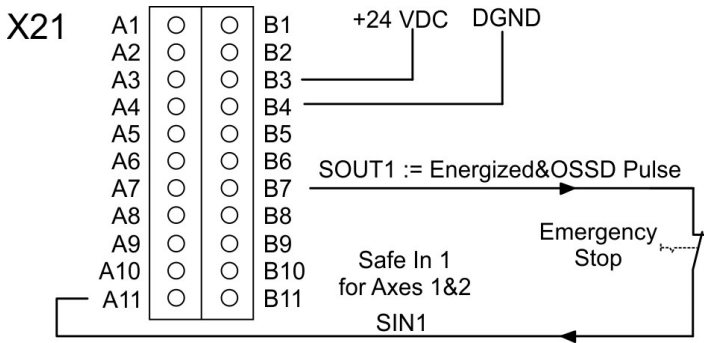

Single channel for axis 1, Emergency Stop, manual restart:

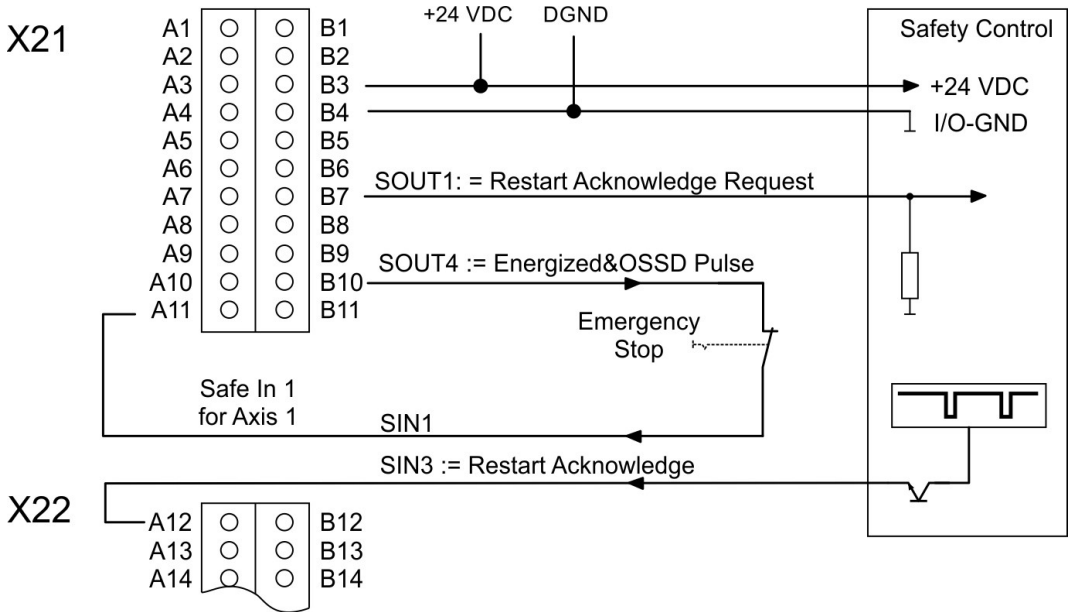

9.4.1.4 Safety Function Response Time Calculation

Basic values, process safety time (PST)

Abbreviation	Process	PST
SIN_PST	Single Input / Dual Input	2.8 ms
Func_PST	Safety function computation	1 ms
STO_Out_PST	STO output change	2.2 ms
FSoE_PST	Minimum FSoE cycle time	5 ms
Pos_Change_PST	Max time to propagate a position change on the encoder to the safety function in the SMM	2.4 ms
Speed_Acceleration_PST	Speed and acceleration computation diagnostic time	6 ms
Brake_Out_PST	Brake output change	4 ms
SOUT_PST	Safe Output change	4 ms
SIN_Fault_Reaction_Time	Safe Input Fault Reaction	5.1 ms

Calculation examples

Time to be set with safety parameters:

- t1 (brake time delay) see [AXIS#.SAFEPARAM.SBC.BRAKETIMEDELAY](#)
- t2 (time to STO) see [AXIS#.SAFEPARAM.SS1_#.TIMETOSTO](#)

Activated by safe inputs (dual or single channel)

Functions	Calculation	Response Time
STO without SBC	$SIN_PST + Func_PST + STO_Out_PST$	6 ms
STO with SBC (1 or 2 brakes) without SDB	$SIN_PST + Func_PST + STO_Out_PST + Brake_Out_PST + t1$	9 ms + t1
STO with SBC with SDB	$SIN_PST + Func_PST + STO_Out_PST$	6 ms
SS1-t with STO (time to activate STO)	$SIN_PST + Func_PST + t2$	3.8 ms + t2
SS1-t with STO with SBC without SDB (time to change brake output)	$SIN_PST + Func_PST(SS1-t) + t2 + Func_PST(STO) + Brake_Out_PST$	8.8 ms + t2

Activated by FSoE

Functions	Calculation	Response Time
STO without SBC	$FSoE_PST + Func_PST + STO_Out_PST$	8.2 ms
STO with SBC (1 or 2 brakes) without SDB	$FSoE_PST + Func_PST + Brake_Out_PST$	10 ms
STO with SBC without SDB	$FSoE_PST + Func_PST + STO_Out_PST + t1$	8.2 ms + t1
STO with SBC with SDB	$FSoE_PST + Func_PST + STO_Out_PST$	8.2 ms

Encoder Position Change

Functions	Calculation	Response Time
Position change to STO	$Pos_Change_PST + Func_PST + STO_Out_PST + t3$	5.6ms + t3
Position change to safe output	$Pos_Change_PST + Func_PST + SOUT_PST + t3$	7.4ms + t3

The SMM is using moving average filters to compute both the velocity and the acceleration. This filtering impacts the response time of the safety functions using speed and/or acceleration and must be considered. When computing the response time, the length of the filter (Speed Computation Time Interval/Acceleration Computation Time Interval) must be added to the numbers of the tables above (t3). The time of these filters is configurable (see [AXIS#.SAFEPARAM.SPEEDCOMPUTATIONINTERVAL](#) and [AXIS#.SAFEPARAM.ACCCOMPUTATIONINTERVAL](#)).

NOTE

In the highly unlikely event that the safe encoder develops an internal fault simultaneously to a feedback reliant safety function being demanded, Pos_Change_PST increases by 5 ms.

9.4.2 Technical Data

9.4.2.1 Safe Digital Inputs

The drive supports 4 safe digital inputs. The safe inputs are configurable for single channel or dual channel, for axis1 or for axis2 or for both axes.

- Reference ground is DGND
- Galvanic isolation for 60 VDC
- Activation delay about 5 μ s
- Deactivation delay about 500 μ s
- Use 24 VDC \pm 15% PELV power supply
- High level > 15 VDC, > 2 mA
- Low level < 5 VDC, < 1 mA
- OSSD test pulses required (\rightarrow # 212)

Safety Level	Single Safe Input	Dual Safe Inputs
SIL2, PLd Cat. 3	✓	✓
SIL3, PLe Cat. 4	—	✓

Pinout

Conn./Pin	Signal	Description
X21 B3	+24 V	+24 VDC for digital I/O
X21 B4	DGND	Ground for digital I/O
X21 A11	SIN1	Configurable, for example SS1 channel A axes 1&2
X21 B11	SIN2	Configurable, for example SS1 channel B axes 1&2
X22 A12	SIN3	Configurable, for example STO channel A axis 2
X22 B12	SIN4	Configurable, for example STO channel B axis 2

Input parameters (setting see "Parameters Editor" (\rightarrow # 293))

Parameter	Name	Description	Default
SAFEPARAM.SINDUAL1.EN	Dual safe input 1	Associates safe inputs SIN1 and SIN2 to dual channel input 1 for an axis.	disabled
SAFEPARAM.SINDUAL2.EN	Dual safe input 2	Associates safe inputs SIN3 and SIN4 to dual channel input 2 for an axis.	disabled
SAFE.IOFAILUREACKSOURCE	Failure acknowledgement via I/O	Specifies the safe digital input, which can be associated for the acknowledgment of the IO failures.	disabled
SAFEPARAM.SIN.DISTINCTPULSE	Digital input distinct test pulse monitoring	Specifies if the safe digital input monitoring for distinct test pulses is enabled	disabled

NOTE

For wiring strategy to be able to reach the necessary SIL/PL, refer to "Activation By Safe Digital Inputs" (\rightarrow # 205).

For descriptions of safety parameters, refer to the *Functional Safety Parameter Reference* "Functional Safety Parameter Reference" (\rightarrow # 315).

If dual channel mode is selected, the drive supervises whether the two inputs are in a different state for longer than 100 ms. If they are different for more than 100 ms, a fault reaction is triggered (see the specific safety function for details).

NOTE

If you configure the safe inputs to accept non-distinct test pulses then you should make a fault exclusion on the input wiring or provide other justification that input wiring faults cannot be dangerous such as cable segregation or individual shielding.

NOTE

The Safety Controller used must be compatible with OSSD (Output Switching Signal Device) according to IEC 61496-1. OSSD requirements (→ # 212).

9.4.2.2 Safe Digital Outputs

The drive has 2 paired or 4 single safe digital outputs in order to signal the safety condition of the drive to an external safety PLC or to activate external devices (for example a (SDB) relay). The safe digital outputs are current sourcing when activated. They are deactivated to indicate a fault condition or activate a safety device.

- Reference ground is DGND (X21/B4)
- Galvanic isolation for 24 VDC from PE
- Use PELV power supply, 24 V ±15%
- Activation delay depends on safety function
- High Level 23.5 V ±15%, 172 mA
- Low level < 1 VDC, < 1 mA
- Emits OSSD test pulses according to IEC 61496-1 (→ # 212)

If an inductive load (relay or similar) is used, a freewheeling diode must be added to the load.

Safety Level	Single safe output	Dual safe outputs
SIL2, PLd Cat. 3	✓	✓
SIL3, PLe Cat. 4	—	✓

Pinout

X21	Signal	Description
B7	SOUT1	Configurable, for example STO status of axis 1
B8	SOUT2	Configurable, for example STO status of axis 2
B9	SOUT3	Configurable
B10	SOUT4	Configurable

Output parameters (setting see "Parameters Editor" (→ # 293))

Parameter	Name	Description	Default
SAFEPARAM.SOUTDUAL#.EN	Dual safe output	Associates two safe outputs to a dual channel output for axis #.	Disabled
SAFEPARAM.SOUTDUAL#.SOURCE	Source selection of safe dual output	Selects the state of a safety function, which is provided for a safe dual output 1/2.	Off
SAFEPARAM.SOUT#.SOURCE	Source selection of safe digital output	Selects the state of a safety function, which is provided for SOUT1 to 4.	Off

NOTE

For descriptions of safety parameters refer to *Functional Safety Parameter Reference* (→ # 315).

9.4.2.3 Factory Defaults without FSoE

NOTICE: After delivery, the drive is ready for operation with a pre-configured STO function.

Item	Parameter	Factory Default
SafeID	SAFE.ID	Rotary switches: "01" (S1 = 0, S2 = 1).
FSoE Address	AXIS#.SAFE.FSOE.CONNECTIONID	Axis 1: 101 (SafeID*100+1) Axis 2: 102 (SafeID*100+2)

Item	Parameter	Factory Default
SIN1, 2	AXIS#.SAFEPARAM.STO.SAFEINPUT	Axis 1: STO
SIN3, 4		Axis 2: STO (dual axis drives only)
SOUT1, 2, 4	SAFEPARAM.SOUT#.SOURCE	0xFF (On)
SOUT3	SAFEPARAM.SOUT#.SOURCE	0x00 (Off)
Password	"SafeMotionMonitorxyz" where "xyz" = last three digits of drive serial number	

Different default settings apply when using SRA parameters.

9.4.2.4 OSSD

Test pulses on safe digital inputs (SIN1 to SIN4)

NOTE The Safety Controller used must be compatible with OSSD (Output Switching Signal Device) according to IEC 61496-1.

Safety controllers check their outputs periodically during normal operation. Their self-test processes create pulses to the safe inputs of the drive.

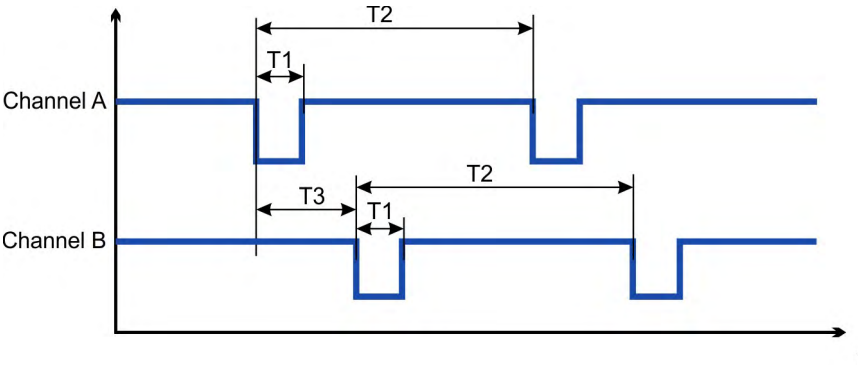

Timing	Min	Max
T1	150 μ s	1 ms
T2	100 ms	1 s
T3	> T1 (non-overlapping)	

NOTE Test pulses with $150 \mu\text{s} \leq T1 \leq 1 \text{ ms}$ and $T2 \geq 100 \text{ ms}$ will not have any influence on the safety function. Test pulses, which are outside of this specification, will switch the safety function but will not create a dangerous situation.

The SMM software enters the I/O Failure State (fault reaction time $\leq 2\text{ms}$)

- if no test pulse is detected for a period of 5 seconds,
- if three test pulses on different channels overlap three times in succession.

Test pulses on safe digital outputs (SOUT1 to SOUT4)

The safe digital outputs can be used as 24 V source voltage to be switched by an external safety relay to STO inputs.

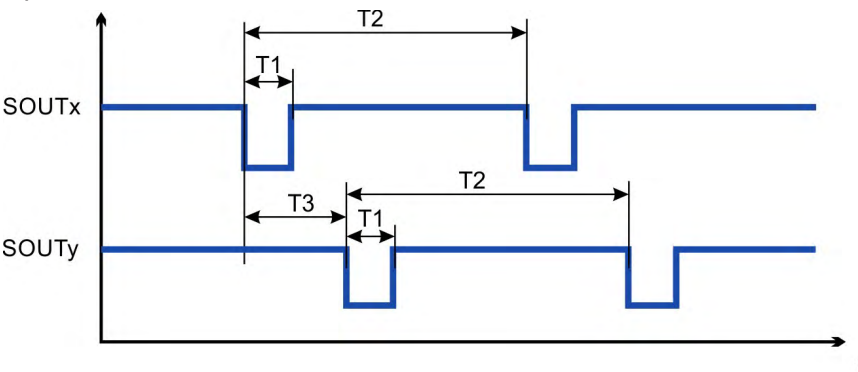

Timing	Min	Max
T1	450 μ s	550 μ s
T2	810 ms	990 ms
T3	> T1 (non-overlapping)	

NOTE

The output test pulses are compatible with the safe digital input requirements. There is only one test pulse on all four outputs at a time. They do not overlap each other. Be sure to use a force-guide relay, converter, or controller that does not respond to these test pulses.

9.4.2.5 FSoE

Safety over

EtherCAT®

AKD2G drives (connectivity option **E**) are connected as slaves to the EtherCAT® network by using RJ45 connectors X11 (out port) and X12 (in port).

- Interface details, see (→ # 155)
- FSoE address setting, see (→ # 290)
- FSoE drive profile, see *AKD2G EtherCAT Manual*
- Activation of FSoE for safety functions, see (→ # 534)
- Parameter download through FSoE, see (→ # 298)

NOTE

The FSoE safety architecture of the AKD2G is supported from TwinCAT 3 (Beckhoff).
For use of an FSoE master from another manufacturer, contact customer service.

The SMM implements an FSoE slave with a single endpoint per axis. The SMM implements the FSoE drive profile and supports fixed data structures for the safe fieldbus only. If configured, the software inverts the error bit of the FSoE status word at the associated safe digital output. The output is off if the error bit is set.

The software of the SMM responds to FSoE Messages within 2 ms after receiving the messages by using the Safe Fieldbus Interface. For examples of response time calculation depending on the safety function combination see (→ # 209).

The SMM software receives the following data in the parameter state of the FSoE Protocol:

- The checksum of the parameters and the drive type identification.
With this the software uses this checksum to validate the parameters received by using CoE.
- No parameter block or a zero checksum (without other parameter).
With this the software uses the parameters transmitted by using other means.

The required data to create the EtherCAT Slave Information file (.ESI file) are provided, including the safety parameters for the transmission by using the safe fieldbus.

FSoE telegram frame RxPDO	FSoE telegram frame TxPDO
Size per frame per axis is 88 bits resulting in a total of 176 bits (22 bytes) for both axes. If an axis is not used, the data are transmitted anyway.	Size per frame per axis is 248 bits resulting in a total of 496 bits (62 bytes) for both axes. If an axis is not used, the data are transmitted anyway.

Related Parameters

Name	Default	Parameter
Activation for safety functions	0	(→ # 534)
Application parameter length	-	(→ # 333)
Communication parameter length	-	(→ # 334)
Connection ID	-	(→ # 335)
Connection type (Slave)	-	(→ # 336)
Protocol Version	-	(→ # 338)
FSoE address	-	(→ # 339)

Name	Default	Parameter
Safety-related application CRC	-	(→ # 340)
Command word send by master	-	(→ # 341)
Actual watchdog time	100 ms	(→ # 342)

Activate FSoE in WorkBench

Select the Parameters Editor view (→ # 291). Choose Common (1) and General (2).



Parameters Editor

[Learn more about this topic](#)

Configuration of the safety parameters.

Axes	Categories
Common 1	General 2
Axis 1	Inputs
Axis 2	Outputs
	Encoders

[Goto Safety Parameter Download](#)

[SafeID: 1] Common > General



Type: **Kollmorgen AKD2G SMM**
 Description: **Kollmorgen AKD2G SafeMotion Monitor**
 Import file: -

Parameter	Value	Unit
Common - General		
SafeID	1	
Safe Fieldbus Activation	Activated	
I/O Failure Acknowledgement	Not used	

9.4.2.6 Motor Brake Requirements

Zero, one, or two brakes can be configured under safe brake control SBC (→ # 240). The brake must be a fail-safe brake with multiple springs. A fail-safe brake is applied when the 24V brake voltage is removed.

Important notes

NOTICE

External brakes must allow operation at 100% duty cycle at 24V. In case of a failure the brake must be rated for the full current at full time.

Brakes are subject to wear. Wear increases by frequency and intensity of use. Avoid overloading the brakes by reducing motor speed with electrical braking before engaging the brakes when possible.

When a brake is used to reduce a risk (usage with SBC), it is part of a safety chain. As part of a safety chain, the brake must fulfill the requirements for functional safety depending on the target SIL or PLr.

The brake PFH_d value shall not occupy more than 50% of the PFH_d value of the whole safety chain. Keep in mind that the PFH_d value of a brake depends on frequency of usage. Kollmorgen brakes offer a B10_d of >15,000,000 use cycles. For more information, refer to the respective *Motor Documentation*.

Example:

A use rate n_{op} of 2/h will result in a PFH_d of 13.3 FIT.

$$PFH_d = 1 / [B10_d / (0.1 * n_{op})] = 1 / [15 * 10^6 / (0.1 * 2/h)] = 13.3 \text{ FIT}$$

Connection

- The first motor brake (built into the motor) can be connected to X1 respectively X2 connectors (→ # 113).
- See (SBC (Safe Brake Control), → # 240).

Brake	Signal	Connector / Pin	
		Single Axis Drive	Dual Axes Drive
1	BRAKE1+		X1/B+
	BRAKE1-		X1/B-
2	BRAKE2+	X4/3	X2/B+
	BRAKE2-	X4/2	X2/B-

Configuration

Safety functions can be configured to use SBC (→ # 240) as part of their fault reaction. You have the option of configuring the fault reaction of a safety function to use:

- No brake.
- One brake per axis. For axis 1 use BRAKE1, for axis 2 use BRAKE2. These brake lines are normally pre-wired on the motor cable.
- Two brakes on a single axis drive. BRAKE1 is normally pre-wired on the motor cable, BRAKE2 is brought out to a separate connector X4.
- Two brakes on axis 1 of a dual axis drive. BRAKE1 is normally pre-wired on the motor cable, BRAKE2 must be wired across from X2.

9.4.2.7 Motor feedback requirements

- Feedback: HIPERFACE DSL
- SIL2 versions of encoder models: EDS35, EDM35, EKS36, EKM36, EES37, EEM37
- Possible connectors: X1 or X2 or X5 (Connector pinout, → # 79)

NOTICE

Encoder and motor housing shall have a positive fit against each other or an adhesive shall be used between both housings. The fitting shall be over dimensioned according to EN IEC 61800-5-3 Annex G to all breakaway torque values. The fatigue strength of the mechanical connection between the encoder shaft and the motor shaft must be shown to have a shaft breakage fault exclusion in accordance with IEC61800-5-2.

HIPERFACE DSL - Initial safety setup

AKD2G SMM can use two safe encoders at the same time (one for each axis). For safety reasons, the safety system must ensure the encoder data are coming from the correct physical encoder. This requires a link between the Axis ID - where you intend to use the safe position - and the physical encoder by writing an encoder index to the encoder memory.

As a result, when the encoder is new or the encoder has been used as a safe feedback with AKD2G but on another Axis ID, you will encounter an I/O failure (“25 - encoder fault: invalid association”) after the setup of the safe encoder in the safety parameters. This is an expected error. Acknowledge the I/O failure in order for the SMM to write the new encoder index in the encoder memory and start operating normally.

Proceed as follows:

1. Use the I/O failure acknowledgement in order to create the link between the axis and the encoder. You can acknowledge I/O failure using FSoE (see FSoE control word) or you can use a safe input. If you use a safe input, it must be configured in the safety parameters:



Parameters Editor

Configuration of the safety parameters.

Axes	Categories
Common	General
Axis 1	Inputs
Axis 2	Outputs
	Encoders

[SafelD: 1] Common > General

Type:	Kollmorgen AKD2G SMM	
Description:	Kollmorgen AKD2G SafeMotion Monitor	
Import file:	-	
Parameter	Value	
Common - General		
SafelD	1	
Safe Fieldbus Activation	Not Activated	
I/O Failure Acknowledgement	Not used	▼
	Not used	
	Safe input 1 (SIN1)	
	Safe input 2 (SIN2)	
	Safe input 3 (SIN3)	
	Safe input 4 (SIN4)	

2. Connect the new HIPERFACE DSL encoder and configure it as a safe feedback in the safety parameter:

Parameters Editor
Configuration of the safety parameters.

Axes	Categories
Common	General
Axis 1	Inputs
Axis 2	Outputs
	Encoders

Increment<=>Encoder Units ratio

[SafeID: 1] Common > Encoders

Encoders (for information only)

Encoder 1 (HF-DSL):	EEM37-2KF0A017A	1 [rev] = 131072 [counts]
Encoder 2 (HF-DSL):	None	N/A
Encoder 3 (EnDat):	None	N/A

Type: **Kollmorgen AKD2G SMM**
Description: **Kollmorgen AKD2G SafeMotion Monitor**
Import file: -

Parameter	Value
Common - Encoders	
Encoder 1 (HF-DSL)	EEM37-2KF0A017A
Encoder 2 (HF-DSL)	Unused
Encoder 3 (EnDat)	Unused

3. Define the encoder source for the axis that you intend to use. The goal is to create a link between the axis ID and the encoder:

Parameters Editor
Configuration of the safety parameters.

Axes	Categories	General
Common	General	Encoder
Axis 1	Safe Stop	User Units
Axis 2	Safe Speed	
	Safe Position	

Scaling Information

[SafeID: 1] Axis 1 > General > Encoder

User Units Scaling (for information only)

Encoder: 1 [rev] = 131072 [counts]	Pos: 3600 [ddeg] = 1 [rev]
Vel: 60 [rpm] = 1 [rev/s]	Acc: 60 [rpm/s] = 1 [rev/s ²]

Resolution (for information only)

Pos: 1 [counts] = 0.0274658203125 [ddeg]
Vel: 1 [counts/s] = 0.000457763671875 [rpm]
Acc: 1 [counts/s ²] = 0.000457763671875 [rpm/s]

Type: **Kollmorgen AKD2G SMM**
Description: **Kollmorgen AKD2G SafeMotion Monitor**
Import file: -

Parameter	Value	Unit
Axis 1 - General - Encoder		
Encoder Source	Encoder 1 (HF-DSL)	
Speed Computation Time Interval	10	ms
Acceleration Computation Time Interval	10	ms
Absolute Position	Disabled	
Absolute Position Range	Unsigned	
Absolute Position Reset Value	0	Position User Units
Absolute Position Reset Source	Not Used	

4. Download and validate the parameters.

If the drive returns I/O Failure 25 continue to step 5:

5. Acknowledge the failure by using FSoE or the configured safe input.

The encoder is now ready to operate as a safe feedback.

For scaling of user units see (Parameterization of User Units, → # 304).

After correct setup each encoder is assigned to the configured axis.

NOTE

Swapping encoders will result in I/O Failure 25. If you swapped the encoders:

- intentionally, repeat step 5.
- by mistake, swap them back without repeating step 5.

The field replacement of the drive is not impacted. The drive can be changed and reconfigured with the encoders plugged in the same connectors. Some examples:

- You swap the safe feedback between axis 1 and axis 2 on the same drive => I/O failure
- You swap the axis 1 safe feedback on one drive to the axis 2 safe feedback on another drive => I/O failure
- You swap the axis 2 safe feedback on one drive to the axis 1 safe feedback on another drive => I/O failure
- You swap axis 1 safe feedback on one drive to the axis 1 safe feedback on another drive => No failure
- You swap axis 2 safe feedback on one drive to the axis 2 safe feedback on another drive => No failure
- You change the drive and plug encoders at the same position => No failure

9.4.3 STO (Safe Torque Off)

This topic describes the **Safe Torque Off** drive option for Functional Safety 2 or 3.

9.4.3.1 Description

STO turns off the drive output stage that powers the motor. STO function corresponds to an uncontrolled stop according to IEC 60204-1, stop category 0.

Important Notes



WARNING No Brake Power!

Serious injury could result when a suspended load is not properly blocked. The drive cannot hold a vertical load when STO is active.

- Add a safe mechanical blocking (for instance, a motor holding brake).
- Configure Safe Brake Control SBC (SBC (Safe Brake Control), → # 240).

NOTICE

It is not possible to perform a controlled stop according to IEC 60204-1 category 1, if STO function is active as standalone function. If controlled stop category 1 is necessary, you should use the SS1-t function (SS1-t (Safe Stop 1), → # 223) respectively SS1-r function (SS1-r (Safe Stop 1), → # 228).

Function Input/Output Variables



Inputs

- **STO Activate** can be activated by:
 - FSoE
 - SS1
 - a fault reaction
 - safe digital inputs (must be mapped)
- **STO Restart Acknowledge** is used for manual restart. The signal can be activated by:
 - FSoE
 - safe digital inputs (must be mapped)

Outputs

- **STO Active** is the logical status of the STO function.
- **STO Restart Request** is used for manual restart. The signal can be evaluated by using FSoE or safe digital outputs (must be mapped).

Number of instances

One instance per axis.

9.4.3.2 Activation

Activation by FSoE	<ul style="list-style-type: none"> For a drive profile overview, see FSoE (FSoE, → # 213). For setup and handling, see the <i>AKD2G EtherCAT Manual</i>.
Activation by safe digital inputs	<ul style="list-style-type: none"> To review the enclosure and wiring instructions, see Enclosure, wiring (Enclosure, wiring, → # 198). To see technical data for the safe inputs, see Technical Data (Technical Data, → # 210). For notes on activation by safe inputs, see Activation by Safety Digital Inputs (Activation By Safe Digital Inputs, → # 205).
Activation with configurable time after SS1	<p>Refer to</p> <ul style="list-style-type: none"> SS1-t function (SS1-t (Safe Stop 1), → # 223) SS1-r function (SS1-r (Safe Stop 1), → # 228).

9.4.3.3 Restart

Restart can be set to either Automatic or Manual (STO Restart Mode, AXIS#.SAFEPARAM.STO.RESTARTACKMODE (AXIS#.SAFEPARAM.STO.RESTARTACKMODE, → # 492)).

Automatic Restart	A restart request signal will be sent to the safety control, when STO is required. With STO restart acknowledge, STO will be deactivated and the axis can be enabled for restart.
Manual Restart	The axis restarts when STO is deactivated and the axis is enabled.

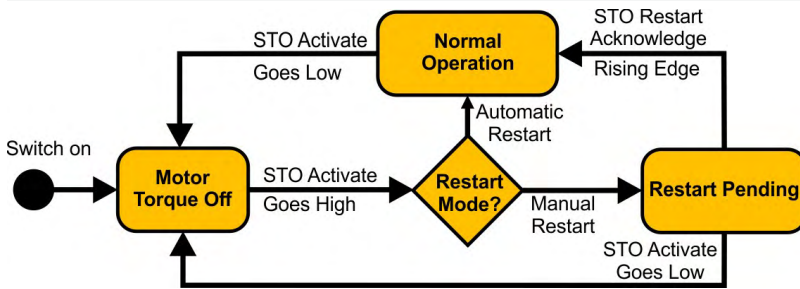

9.4.3.4 Timing

Timing for activation by SS1-t: Refer to SS1-t/r function (SS1-r (Safe Stop 1), → # 228).

Timing for activation by FSoE: Refer to the *AKD2G EtherCAT Manual*.

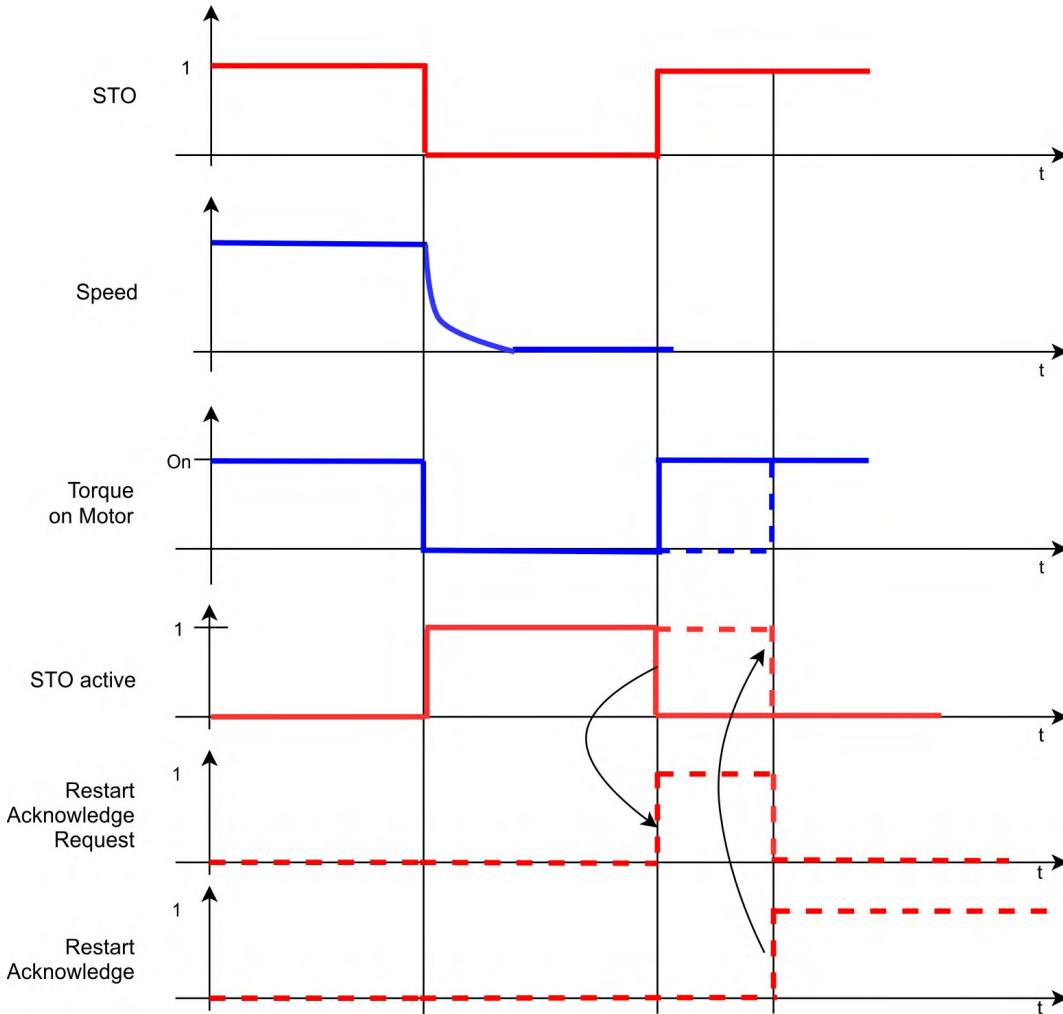

9.4.3.5 Related Parameters

Safety Parameters

Name	Variables	Default	Parameter
Function Activation	-	1 (Ready for activation)	(<code>AXIS#.SAFEPARAM.STO.FUNCTIONACTIVATION</code> , → # 491)
Safe Input	-	Axis 1 – 5 (Safe Dual 1) Axis 2 – 6 (Safe Dual 2)	(<code>AXIS#.SAFEPARAM.STO.SAFEINPUT</code> , → # 494)
FSoE	-	0 (Not used)	(<code>AXIS#.SAFEPARAM.STO.FSOE</code> , → # 490)

Diagnostic Parameters

Name	Variables	Default	Parameter
Function Actual Active Status	-	-	(<code>AXIS#.SAFE.STO.ACTIVE</code> , → # 382)

Name	Variables	Default	Parameter
Reportfault	-	-	(AXIS#.SAFE.STO.REPORTFAULT, → # 383)

When using manual restart, map the Restart Request Source to a safe output, see (Parameters Editor, → # 293).

9.4.3.6 Setup in WorkBench

Select the drive and open the Safety Parameterization view (Parameters Editor, → # 293).

Parameters Editor [Learn more about this topic](#)

Configuration of the safety parameters.

Axes	Categories	Safe Stop	Instances
Common	General	STO (Safe Torque Off)	Instance 1 (Fault Reaction)
Axis 1	Safe Stop	SS1 (Safe Stop 1)	
Axis 2	Safe Speed	SS2 (Safe Stop 2)	
	Safe Position	SOS (Safe Operating Stop)	
		SBC (Safe Brake Control)	
		SBT (Safe Brake Test)	
		SDB (Safe Dynamic Brake)	

[Goto Safety Parameter Download](#)

1. Choose the axis.
2. Select the Category.
3. Select the STO function.
4. The instance number is not applicable for STO.

[SafeID: 1] Axis 1 > Safe Stop > STO (Safe Torque Off) > Instance 1 (Fault Reaction)

Type: **Kollmorgen AKD2G SMM**
 Description: **Kollmorgen AKD2G SafeMotion Monitor**
 Import file: -

Parameter	Value	Unit
Axis 1 - Safe Stop - STO - Instance 1 (Fault Reaction)		
Function Activation	Ready for Activation	
Safe Input	Safe input 2 (SIN2)	
FSoE	Not Used	
Restart Acknowledge Behavior	Manual Restart	
Restart Acknowledge Source	Safe input 3 (SIN3)	

Note: If you want to have one dual input (e.g. SIN1/SIN2) activate STO for both axis 1 and axis 2, then you must set the activation parameter for both axes to the same input.

9.4.3.7 Fault Reaction/ Failure Messages

If dual channel mode is selected, the AKD2G observes to see if the two inputs are in a different state for longer than 100 ms. If the two inputs are in different states for more than 100 ms, an I/O failure activates SS1_1 and then the axis torque is switched off by STO.

An I/O failure warning is issued when the AKD2G is disabled or a fault when the AKD2G is enabled and AXIS#.SAFE.STO.REPORTFAULT (AXIS#.SAFE.STO.REPORTFAULT, → # 383) is set to 1.

9.4.3.8 Safety Diagnostic for the Safe I/O view in WorkBench

The WorkBench Safe I/O view shows the current status on the safe inputs and the logical status of the STO function for every axis.

Safe I/O
Safety functions monitoring

General Safe I/Os

sts

SIN 1

SIN 2

SIN 3

SIN 4

SINDUAL 1

9.4.3.9 Safety Properties

Refer to (Safety Properties Overview, → # 203).

9.4.4 SS1-t (Safe Stop 1)

SS1-t (time controlled) description for drive option Functional Safety 2 or 3.

9.4.4.1 Description

With the time based function "Safe Stop 1" (SS1-t) the drive is stopped by a controlled stop with the configured deceleration ramp. When the time t_{SS1} (AXIS#.SAFEPARAM.SS1_#.TIMETOSTO, → # 464) is elapsed, STO is activated. SS1 Instance 1 can be configured as the fault reaction for safety functions SS2, SSR, SDI, SLA, SAR, SLI,SLP and SLS.

SS1 function corresponds to a controlled stop according to IEC 60204-1, stop category 1. The controlled stop is executed in the unsafe part of the drive. The deceleration ramp (AXIS#.SAFE.SS1_#.DEC, → # 371) is part of the standard drive parameter. The STO function is a safe function.

Function Input / Output Variables

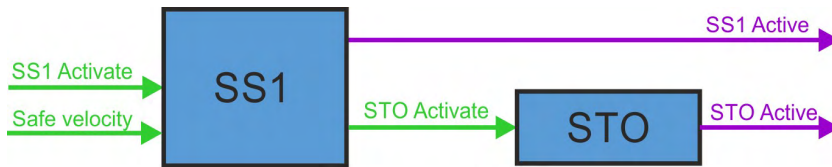

Inputs

- **SS1 Activate** can be activated by
 - FSoE,
 - I/O failure (instance 1 only),
 - safe digital inputs (must be mapped) or
 - other safety functions as fault reaction.

Outputs

- **SS1 Active**: logical status of the SS1 function
- **STO Active**: logical status of the STO function
- **STO Activate** is activated by SS1

Number of Instances

Three instances per axis.

9.4.4.2 Activation

NOTE

To use SS1-t, Velocity & Deceleration Monitoring must be disabled in the safety parameters on a FS3 drive. On a FS2 drive, only SS1-t is available. If SS1_2 or SS1_3 is set to "Not Used", the corresponding FSoE activation bit is ignored even if (SAFEPARAM.SAFEFIELDBUS.ACTIVATION, → # 534) is 1.

Activation by FSoE	<ul style="list-style-type: none"> • For a drive profile overview, see FSoE (FSoE, → # 213). • For setup and handling, see the <i>AKD2G EtherCAT Manual</i>.
Activation by safe digital inputs	<ul style="list-style-type: none"> • To review the enclosure and wiring instructions, see Enclosure, wiring (Enclosure, wiring, → # 198). • To see technical data for the safe inputs, see Technical Data (Technical Data, → # 210). • For notes on activation by safe inputs, see Activation by Safety Digital Inputs (Activation By Safe Digital Inputs, → # 205).

9.4.4.3 Safety Properties

Refer to (Safety Properties Overview, → # 203).

9.4.4.4 Restart

(STO (Safe Torque Off), → # 219)

9.4.4.5 Timing

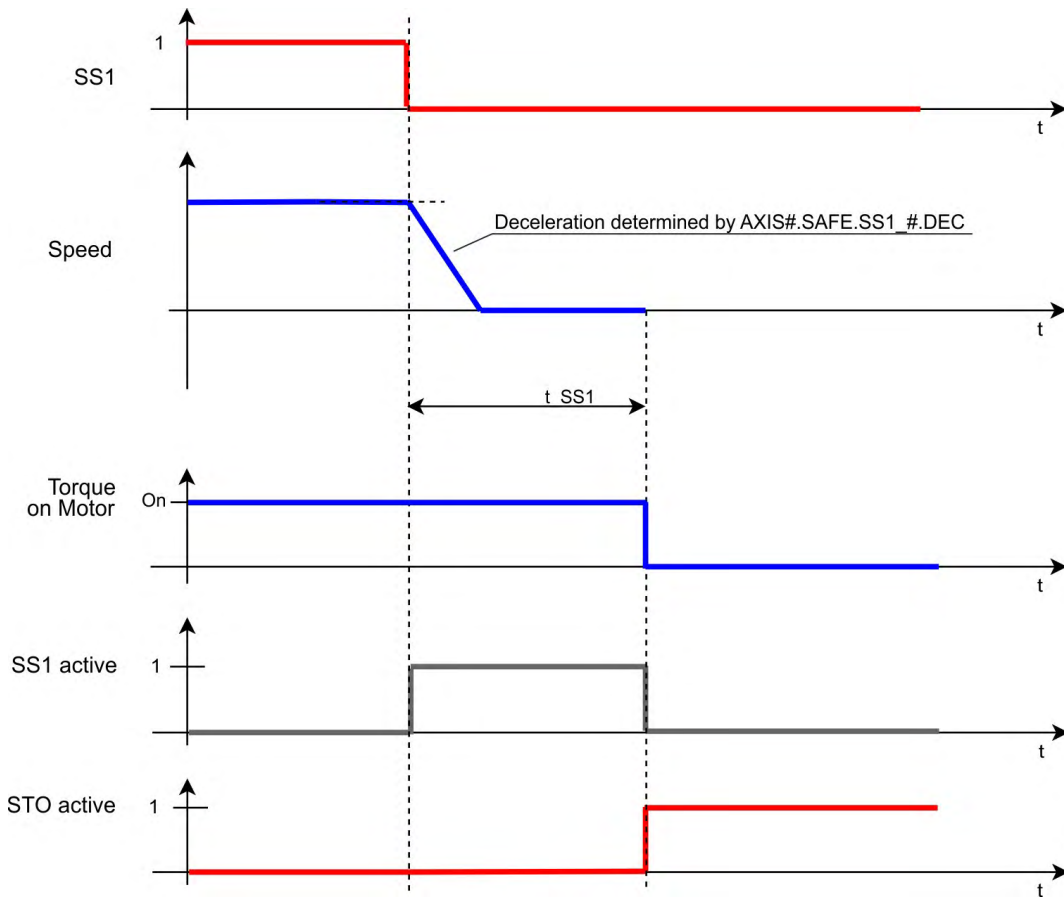

Notes:

- SS1 is fully completed after activation until STO is activated, even if the request (SS1_Activate) is reset in between.
- The additional time for the optional closing of the brakes is not included in this diagram. For more information refer to (SBC (Safe Brake Control), → # 240)
- See limitations for FSoE (→ # 1, Limitations for SMM1) (Limitations, → # 553)

9.4.4.6 Related Parameters

Safety parameters

Name	Variables	Default	Parameter
Function Activation	-	Inst. 1: 1 (Ready for activation) Inst. 2,3: 0 (Never active)	(AXIS#.SAFEPARAM.SS1_#.FUNCTIONACTIVATION, → # 460)
Safe Input	-	0 (Not used)	(AXIS#.SAFEPARAM.SS1_#.SAFEINPUT, → # 461)
FSoE	-	0 (Not used)	(AXIS#.SAFEPARAM.SS1_#.FSOE, → # 459)
Time To STO	t_SS1	2 ms	(AXIS#.SAFEPARAM.SS1_#.TIMETOSTO, → # 464)
Velocity & Deceleration Monitoring	-	0 (Disabled)	(AXIS#.SAFEPARAM.SS1_#.VELDECMONITOREN, → # 465)

Diagnostic parameters

Name	Variables	Default	Parameter
Function Active Status	-	-	(AXIS#.SAFE.SS1_#.ACTIVE, → # 370)
Function Internal Status	-	-	(AXIS#.SAFE.SS1_#.INTERNALSTATE, → # 372)

Device parameters

Name	Variables	Default	Parameter
Deceleration Mode	-	0 (Drive driven)	(AXIS#.SAFE.SS1_#.MODE, → # 373)
Deceleration Ramp	-	9999.946 rpm/s	(AXIS#.SAFE.SS1_#.DEC, → # 371)

9.4.4.7 Setup in WorkBench

Select the drive and open the Safety Parameterization view (Parameters Editor, → # 293).

Parameters Editor [Learn more about this topic](#)

Configuration of the safety parameters.

Axes	Categories	Safe Stop	Instances
Common	General	STO (Safe Torque Off)	Instance 1 (Fault Reaction)
Axis 1	Safe Stop	SS1 (Safe Stop 1)	Instance 2
Axis 2	Safe Speed	SS2 (Safe Stop 2)	Instance 3
	Safe Position	SOS (Safe Operating Stop)	
		SBC (Safe Brake Control)	
		SBT (Safe Brake Test)	
		SDB (Safe Dynamic Brake)	

[Goto Safety Parameter Download](#)

1. Choose the axis
2. Select the category
3. Select the SS1 function
4. Select the instance number

[SafeID: 1] Axis 1 > Safe Stop > SS1 (Safe Stop 1) > Instance 1 (Fault Reaction)

User Units (for information only)
 Position: N/A Velocity: N/A Acceleration: N/A

Type: **Kollmorgen AKD2G SMM**
 Description: **Kollmorgen AKD2G SafeMotion Monitor**
 Import file: -

Parameter	Value	Unit
Axis 1 - Safe Stop - SS1 - Instance 1 (Fault Reaction)		
Function Activation	Ready for Activation	
Safe Input	Not Used	
FSoE	Not Used	
Time to STO (t_SS1)	2	ms
Velocity & Deceleration Monitoring	Disabled	
Velocity Zero Window (n_Zero_SS1)	1	Velocity User Units
Time for Velocity Zero (t_L_SS1)	1	ms
Deceleration Limit (a_SS1)	0	Acceleration User Units
Time Delay Deceleration Monitoring (t_D_SS1)	1	ms

Validation Results (0)

Device Related Parameters (2)

Mode:

Deceleration Ramp: rpm/s

If one dual input (e.g. SIN1/SIN2) activates SS1-t for both Axis 1 and Axis 2, set the Activation parameter for both axes to the identical input (e.g. Safe Dual Input 1).

9.4.4.8 Fault Reaction / Failure Messages

If dual channel mode is selected, the AKD2G sees if the two inputs are in a different state for more than 100 ms. If the two inputs are in different state for more than 100 ms, an I/O failure activates SS1_1 and then STO is activated. An I/O failure warning is displayed.

SS1 Instance 1 can be configured as the fault reaction for other safety functions. Functions which support this feature are SS2, SSR, SDI, SLA, SAR, SLI, SLP and SLS.

9.4.4.9 Safety State / Status Signals

The signal `AXIS#.SAFE.SS1_#.ACTIVE` can be monitored by safe digital outputs with OSSD pulses (OSSD, → # 212). The status signal must be mapped to the safe digital output. Two outputs can be combined to a dual channel output. For parameter description see (Functional Safety Parameter Reference, → # 315).

9.4.5 SS1-r (Safe Stop 1)

SS1-r description for drive option Functional Safety 3.

9.4.5.1 Description

SS1-r, when activated, monitors the controlled stop of the axis until the STO function can be activated. SS1 Instance 1 can be configured as the fault reaction for safety functions SS2, SSR, SDI, SLA, SAR, SLI, SLP and SLS. During the process, the SS1-r function monitors the velocity. If the velocity stays in the range (n_Zero_SS1) within the time (t_L_SS1) STO activates in advance. In any case, STO activates as soon as the timer (t_SS1) elapsed. Optionally, SS1-r can monitor the ramp of the controlled stop. The parameter a_SS1 defines the deceleration limit that the axis is not allowed to pass. The parameter t_D_SS1 is used to delay the start of the deceleration monitoring after the SS1 function activated.

Number of Instances

Three instances per axis.

Function Input / Output Variables



Inputs

- **SS1 Activate** can be triggered by
 - FSoE,
 - a fault reaction,
 - I/O failure (instance 1 only) or
 - safe digital inputs (must be mapped).
- **STO Activate** is triggered by SS1.

Outputs

- **SS1 Active**: logical status of the SS1 function
- **STO Active**: logical status of the STO function

9.4.5.2 Activation

NOTE	<p>To activate SS1-r, Velocity & Deceleration Monitoring must be enabled in the safety parameters. If not, SS1-t is used.</p> <p>The safety function can be mapped with WorkBench or by using FSoE to the safe digital inputs or other functions.</p> <p>If SS1_2 or SS1_3 is set to “Not Used”, the corresponding FSoE activation bit is ignored even if SAFEFIELDDBUS.ACTIVATION is 1 (SAFEPARAM.SAFEFIELDDBUS.ACTIVATION, → # 534).</p>
-------------	----------------------------------------------------------------------------------------------------------------------------------------------------------------------------------------------------------------------------------------------------------------------------------------------------------------------------------------------------------------------------------------------------------------------------------------------------------------

Activation by FSoE	<ul style="list-style-type: none"> • For a drive profile overview, see FSoE (FSoE, → # 213). • For setup and handling, see the <i>AKD2G EtherCAT Manual</i>.
---------------------------	--------------------------------------------------------------------------------------------------------------------------------------------------------------------------------------

<p>Activation by safe digital inputs</p>	<ul style="list-style-type: none"> • To review the enclosure and wiring instructions, see Enclosure, wiring (Enclosure, wiring, → # 198). • To see technical data for the safe inputs, see Technical Data (Technical Data, → # 210). • For notes on activation by safe inputs, see Activation by Safety Digital Inputs (Activation By Safe Digital Inputs, → # 205).
-------------------------------------------------	-------------------------------------------------------------------------------------------------------------------------------------------------------------------------------------------------------------------------------------------------------------------------------------------------------------------------------------------------------------------------------------------------------

9.4.5.3 Safety Properties

Refer to (Safety Properties Overview, → # 203).

9.4.5.4 Restart

Refer to (SS1-t (Safe Stop 1), → # 223).

9.4.5.5 Timing

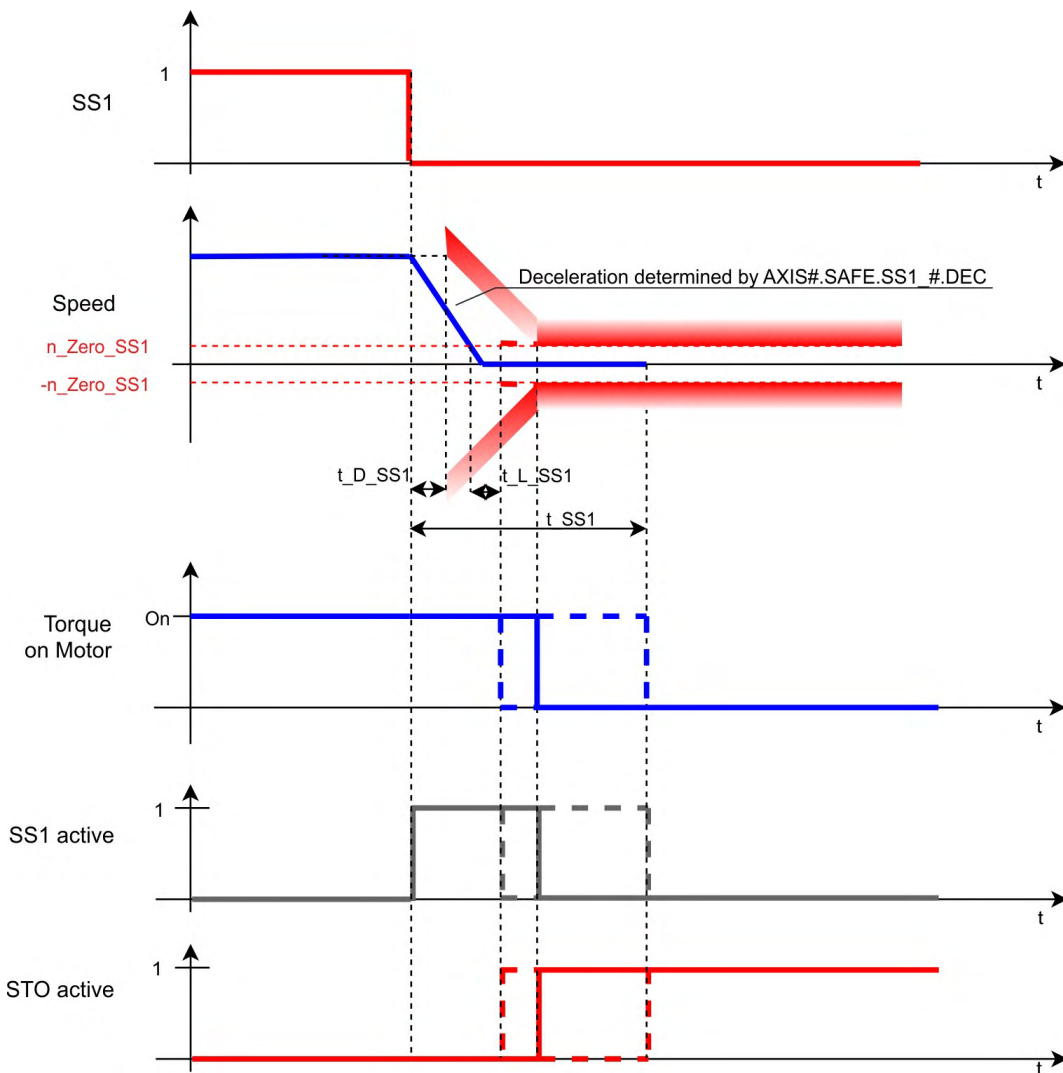

Note:

- SS1 is fully completed after activation until STO is activated, even if the request (SS1_Activate) is reset in between.
- See limitations for FSoE (→ # 1, Limitations for SMM1) (Limitations, → # 553)

9.4.5.6 Related Parameters

Safety parameters

Name	Variables	Default	Parameter
Function Activation	-	Inst. 1: 1 (Ready for activation) Inst. 2,3: 0 (Never active)	(AXIS#.SAFEPARAM.SS1_#.FUNCTIONACTIVATION, → # 460)
Safe Input	-	0 (Not used)	(AXIS#.SAFEPARAM.SS1_#.SAFEINPUT, → # 461)
FSoE	-	0 (Not used)	(AXIS#.SAFEPARAM.SS1_#.FSOE, → # 459)
Time To STO	t_SS1	2 ms	(AXIS#.SAFEPARAM.SS1_#.TIMETOSTO, → # 464)
Velocity & Deceleration Monitoring	-	0 (Disabled)	(AXIS#.SAFEPARAM.SS1_#.VELDECMONITOREN, → # 465)
Velocity Zero Window	n_Zero_SS1	1	(AXIS#.SAFEPARAM.SS1_#.VELZEROWINDOW, → # 466)
Time For Velocity Zero	t_L_SS1	1 ms	(AXIS#.SAFEPARAM.SS1_#.TIMEFORVELZERO, → # 463)
Deceleration Limit	a_SS1	0	(AXIS#.SAFEPARAM.SS1_#.DECLIMIT, → # 458)
Time Delay Deceleration Monitoring	t_D_SS1	1 ms	(AXIS#.SAFEPARAM.SS1_#.TIMEDELAYDECMONITORING, → # 462)

Diagnostic Parameters

Name	Variables	Default	Parameter
Function Active Status	-	-	(AXIS#.SAFE.SS1_#.ACTIVE, → # 370)
Function Internal Status	-	-	(AXIS#.SAFE.SS1_#.INTERNALSTATE, → # 372)

Device Parameters

Name	Variables	Default	Parameter
Deceleration Mode	-	0 (Drive driven)	(AXIS#.SAFE.SS1_#.MODE, → # 373)
Deceleration Ramp	-	9999.946 rpm/s	(AXIS#.SAFE.SS1_#.DEC, → # 371)

9.4.5.7 Setup in WorkBench

Select the drive and open the Safety Parameterization view (Parameters Editor, → # 293).

Parameters Editor
Configuration of the safety parameters.

Axes	Categories	Safe Stop	Instances
Common	General	STO (Safe Torque Off)	Instance 1 (Fault Reaction)
Axis 1	Safe Stop	SS1 (Safe Stop 1)	Instance 2
Axis 2	Safe Speed	SS2 (Safe Stop 2)	Instance 3
	Safe Position	SOS (Safe Operating Stop)	
		SBC (Safe Brake Control)	
		SBT (Safe Brake Test)	
		SDB (Safe Dynamic Brake)	

[Goto Safety Parameter Download](#)

1. Choose the Axis.
2. Select the Category.
3. Select the SS1 function.
4. Select the Instance number.
5. Enable **Velocity & Deceleration Monitoring** to activate SS1-r.

[SafeID: 1] Axis 1 > Safe Stop > SS1 (Safe Stop 1) > Instance 1 (Fault Reaction)

User Units (for information only)
Position: N/A Velocity: N/A Acceleration: N/A

Type: **Kollmorgen AKD2G SMM**
Description: **Kollmorgen AKD2G SafeMotion Monitor**
Import file: -

Parameter	Value	Unit
Axis 1 - Safe Stop - SS1 - Instance 1 (Fault Reaction)		
Function Activation	Ready for Activation	
Safe Input	Not Used	
FSoE	Not Used	
Time to STO (t_SS1)	2	ms
Velocity & Deceleration Monitoring	Enabled	
Velocity Zero Window (n_Zero_SS1)	1	Velocity User Units
Time for Velocity Zero (t_L_SS1)	1	ms
Deceleration Limit (a_SS1)	0	Acceleration User Units
Time Delay Deceleration Monitoring (t_D_SS1)	1	ms

Validation Results (0)

Device Related Parameters (2)

Mode:

Deceleration Ramp: rpm/s

If one dual input (e.g. SIN1/SIN2) activates SS1-r for both axis 1 and axis 2, then set the Activation parameter for both axes to the same input (e.g. Safe Dual Input 1).

9.4.5.8 Fault Reaction / Failure Message

If dual channel mode is selected, the AKD2G observes to see if the two inputs are in a different state for more than 100 ms. If the two inputs are in different states for more than 100 ms, an I/O failure activates SS1_1 and then the axis is switched off by STO. An I/O failure warning is displayed.

SS1 Instance 1 can be configured as the fault reaction for other safety functions. Functions which support this feature include: SS2, SSR, SDI, SLA, SAR, SLI, SLP and SLS.

9.4.5.9 Safety State / Status Signals

The signal AXIS#.SAFE.SS1_#.ACTIVE (AXIS#.SAFE.SS1_#.ACTIVE, → # 370) can be monitored by safe digital outputs with OSSD pulses (OSSD, → # 212). The status signal must be mapped to the safe digital output. Two outputs can be combined to a dual channel output. For parameter descriptions see (Functional Safety Parameter Reference, → # 315).

9.4.6 SS2 (Safe Stop 2)

Description of SS2 with deceleration monitoring enabled for drive option Functional Safety 3.

9.4.6.1 Description

SS2, when activated, monitors the controlled stop on a given axis until it is ready to activate SOS.

The SS2 function monitors the velocity of the controlled stop. If the velocity stays in the range (n_Zero_SOS) within the time (t_L_SS2) SOS activates in advance. In any case, SOS activates as soon as the timer (t_SS2) elapsed.

Optionally, the ramp of the controlled stop can be monitored. The parameter a_SS2 defines the deceleration limit that the axis cannot pass. The parameter t_D_SS2 is used to delay the start of the deceleration monitoring after the SS2 function activated.

SMM R_02-XX-XXXX

NOTE

NOTE

- In order to use SS2, enable SOS velocity monitoring and set a valid n_Zero_SOS velocity limit.
- SS2 instance 1 uses SOS instance 1 and SS2 instance 2 uses SOS instance 2.

Number of Instances

Two instances per axis.

Function Input / Output Variables

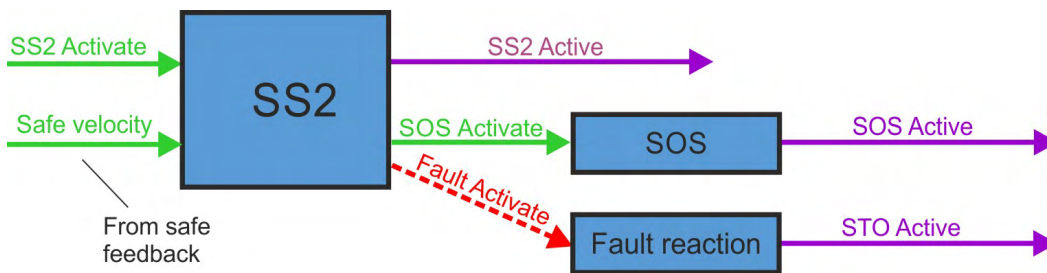

Inputs

- **SS2 Activate** can be triggered by any of the following:
 - FSoE
 - safe digital inputs (must be mapped)
 - other safety functions as fault reaction*.
- **Safe velocity**: velocity signal from safe feedback

Outputs

- **SS2 Active**: logical status of the SS2 function
- **Fault Activate**: activate fault reaction

*SS2 instance 1 can be configured as fault reaction for: SSR, SDI, SLA, SAR, SLI, SLP and SLS.

9.4.6.2 Activation

Activation by FSoE	<ul style="list-style-type: none"> For a drive profile overview, see FSoE (FSoE, → # 213). For setup and handling, see the <i>AKD2G EtherCAT Manual</i>.
Activation by safe digital inputs	<ul style="list-style-type: none"> To review the enclosure and wiring instructions, see Enclosure, wiring (Enclosure, wiring, → # 198). To see technical data for the safe inputs, see Technical Data (Technical Data, → # 210). For notes on activation by safe inputs, see Activation by Safety Digital Inputs (Activation By Safe Digital Inputs, → # 205).

9.4.6.3 Safety Properties

Refer to (Safety Properties Overview, → # 203).

9.4.6.4 Timing

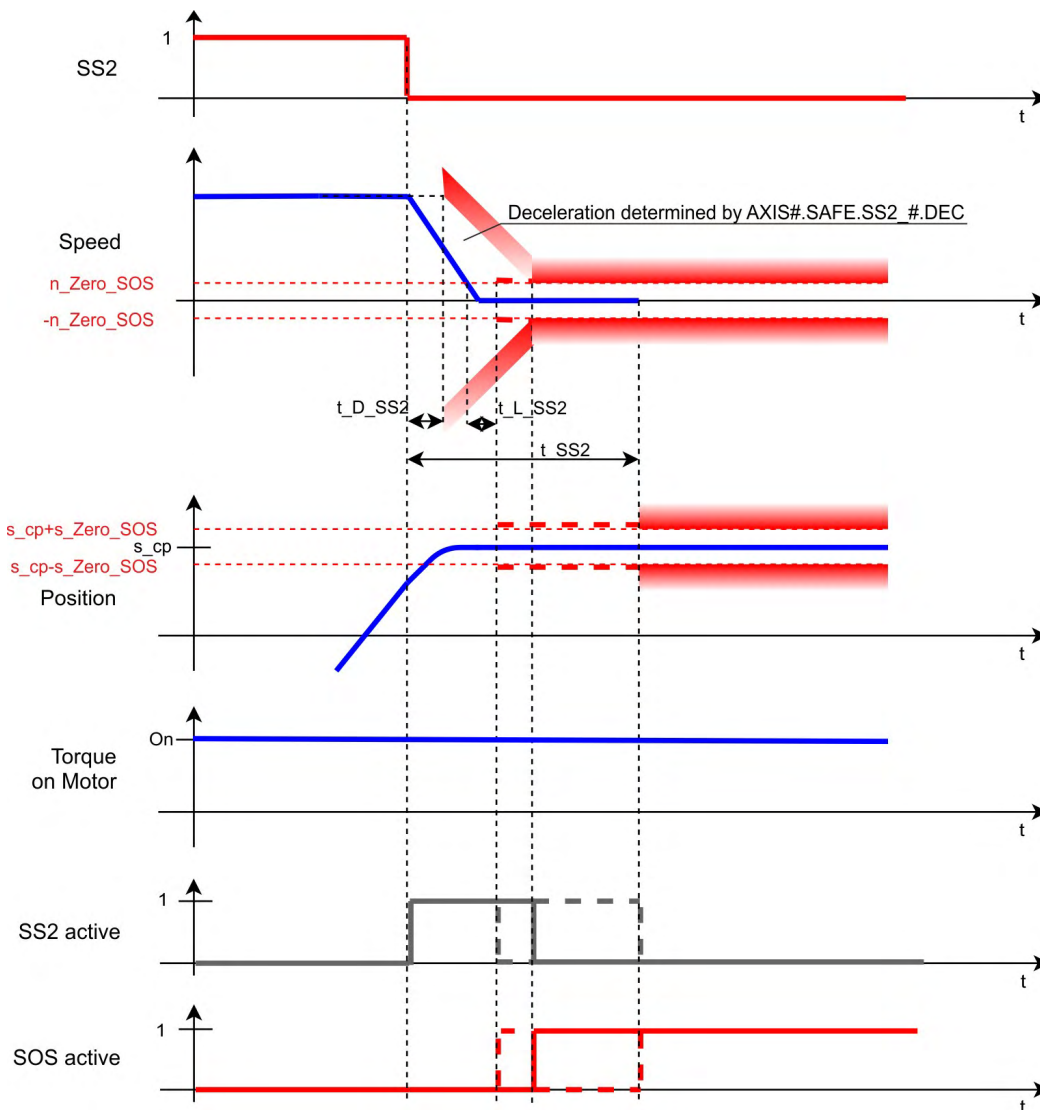

Note:

- SS2 is fully completed after activation until SOS is activated, even if the request (SS2_Activate) is reset in between.

The position `s_cp` is defined when the monitoring of the SOS function begins. It is used to compute the range of allowed position values that the axis can take while the position monitoring is activated. The range is computed by adding or subtracting `s_Zero_SOS` to/from the parameter `s_cp`.

9.4.6.5 Related Parameters

Safety parameters

Name	Variables	Default	Parameter
Function Activation	-	0 (Never active)	(→ # 471)
Safe Input	-	0 (Not used)	(→ # 472)
FSoE	-	0 (Not used)	(→ # 470)
Time To SOS	<code>t_SS2</code>	2 ms	(→ # 475)
Time For Velocity Zero	<code>t_L_SS2</code>	1 ms	(→ # 474)
Deceleration Monitoring	-	0 (Disabled)	(→ # 468)
Deceleration Limit	<code>a_SS2</code>	0 (Dec user units)	(→ # 467)
Time Delay Deceleration Monitoring	<code>t_D_SS2</code>	1 ms	(→ # 473)
Fault Reaction	-	1 (STO)	(→ # 469)

Diagnostic parameters

Name	Variables	Default	Parameter
Function Active Status	-	-	(→ # 374)
Function Internal Status	-	-	(→ # 376)

Device parameters

Name	Variables	Default	Parameter
Deceleration Mode	-	0 (Drive driven)	(→ # 377)
Deceleration Ramp	-	9999.946 rpm/s	(→ # 375)

9.4.6.6 Setup in WorkBench

Select the drive and open the Safety Parameterization view (→ # 293).



Parameters Editor

Configuration of the safety parameters.

[Learn more about](#)

1. Choose the Axis
2. Select the Category
3. Select the SS2 function
4. Select the Instance number

Common	Categories	Safe Stop	Instances
Axis 1	Safe Stop	STO (Safe Torque Off)	Instance 1 (Fault Reaction)
Axis 2	Safe Speed	SS1 (Safe Stop 1)	Instance 2
	Safe Position	SS2 (Safe Stop 2)	
		SOS (Safe Operating Stop)	
		SBC (Safe Brake Control)	
		SBT (Safe Brake Test)	
		SDB (Safe Dynamic Brake)	

[Goto Safety Parameter](#)

[SafeID: 1] Axis 1 > Safe Stop > SS2 (Safe Stop 2) > Instance 1 (Fault Reaction)

User Units (for information only)

Position: N/A

Velocity: N/A

Acceleration: N/A

Parameter	Value	Unit
Axis 1 - Safe Stop - SS2 - Instance 1 (Fault Reaction)		
Function Activation	Ready for Activation	
Safe Input	Not Used	
FSoE	Not Used	
Time to SOS (t_SS2)	2	ms
Time For Velocity Zero (t_L_SS2)	1	ms
Deceleration Monitoring	Enabled	
Deceleration Limit (a_SS2)	0	Acceleration User Units
Time Delay Deceleration Monitoring (t_D_SS2)	1	ms
Fault Reaction	STO	

[Validation Results \(0\)](#)

Device Related Parameters (2)

Mode:

Deceleration Ramp: rpm/s

9.4.6.7 Fault Reaction / Failure Messages

SS2 has a configurable fault reaction. STO is used by default but can be replaced by SS1 Instance 1. When the fault reaction is activated, the internal state ([AXIS#.SAFE.SS2_#.INTERNALSTATE](#)) is set to failed state (5).

SS2 Instance 1 can be configured as the fault reaction for other safety functions. Functions which support this feature are SSR, SDI, SLA, SAR, SLI, SLP and SLS.

9.4.6.8 Safety State / Status Signals

The signal [AXIS#.SAFE.SS2_#.ACTIVE](#) can be monitored by safe digital outputs with OSSD pulses (→ # 212). The status signal must be mapped to the safe digital output. Two outputs can be combined to a dual channel output. For parameter description refer to (→ # 315).

9.4.7 SOS (Safe Operating Stop)

SOS description for drive option Functional Safety 3.

9.4.7.1 Description

SOS monitors the position of the axis and ensures that it stays in a position window. The position of this window is defined when the monitoring starts. The upper and the lower limit of the position window are defined by the parameter `s_Zero_SOS`. If the position leaves the position window, the fault reaction STO will be activated.

Optionally, the velocity can be monitored to ensure that it stays in a window defined by the parameter `n_Zero_SOS`. The start of the position/velocity monitoring can be delayed by using the parameter `t_D_SOS`. This delay gives the axis the necessary time to stop.

SOS can be activated by a safe input and/or FSoE and/or the SS2 function. The SS2 function, when used, will detect whether the velocity is low enough to activate SOS by means of the parameter `n_Zero_SOS`. This is why it is important to set a correct value to `n_Zero_SOS`. A value of 0 will most likely lead to a SS2 failure so that SS2 will activate its fault reaction.

Number of Instances

Two instances per axis.

Function Input / Output Variables

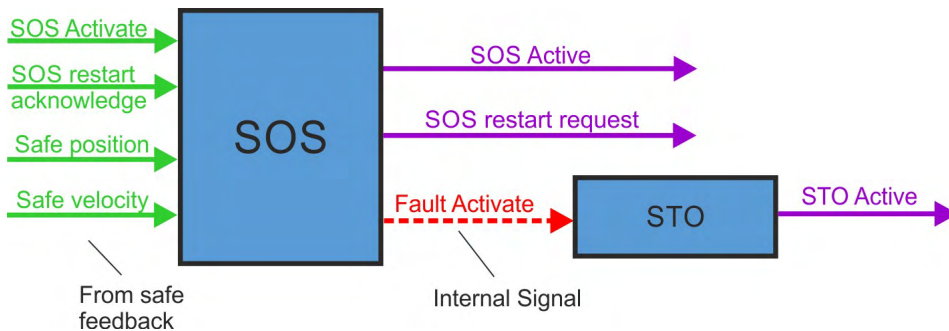

Inputs

- **SOS Activate** can be triggered by
 - FSoE,
 - safe digital inputs (must be mapped) or
 - the SS2 function.
- **Safe position**: signal from safe feedback
- **Safe velocity**: velocity signal derived from safe feedback position
- **SOS Restart Acknowledge** is used for manual restart. The signal can be triggered by
 - FSoE or
 - safe digital inputs (must be mapped).

Outputs

- **SOS Active**: logical status of the SOS function
- **Fault Activate**: activate STO fault reaction
- **SOS Restart Request**: request for manual restart.

9.4.7.2 Activation

Activation by FSoE	<ul style="list-style-type: none"> For a drive profile overview, see FSoE (FSoE, → # 213). For setup and handling, see the <i>AKD2G EtherCAT Manual</i>.
Activation by safe digital inputs	<ul style="list-style-type: none"> To review the enclosure and wiring instructions, see Enclosure, wiring (Enclosure, wiring, → # 198). To see technical data for the safe inputs, see Technical Data (Technical Data, → # 210). For notes on activation by safe inputs, see Activation by Safety Digital Inputs (Activation By Safe Digital Inputs, → # 205).

9.4.7.3 Restart

Restart can be set as "automatic" or "manual".

Automatic restart	SOS will be deactivated automatically
Manual restart	To deactivate SOS, send a safe restart request to the safety control by using FSoE or safe input

For further information see State Diagram (→ # 236).

9.4.7.4 Related Parameters

Safety parameters

Name	Variables	Default	Parameter
Function Activation	-	0 (Never active)	AXIS#.SAFEPARAM.SOS.FUNCTIONACTIVATION
Safe Input	-	0 (Not used)	AXIS#.SAFEPARAM.SOS.SAFEINPUT
FSoE	-	0 (Not used)	AXIS#.SAFEPARAM.SOS.FSOE
Position Zero Window	s_Zero_SOS	1 (Pos user units)	AXIS#.SAFEPARAM.SOS.POSZEROWINDOW; usable value range depends on used encoder type, see (Limitations, → # 553)
Velocity Monitoring	-	0 (Disabled)	AXIS#.SAFEPARAM.SOS.VELMONITOREN
Velocity Zero Window	n_Zero_SOS	0 (Vel user units)	AXIS#.SAFEPARAM.SOS.VELZEROWINDOW
Time Delay Monitoring	t_D_SOS	1 ms	AXIS#.SAFEPARAM.SOS.TIMEDELAYMONITORING
Restart Acknowledge Behaviour	-	0 (Automatic restart)	AXIS#.SAFEPARAM.SOS.RESTARTACKBEHAVIOR
Restart Acknowledge Source	-	0 (Not used)	AXIS#.SAFEPARAM.SOS.RESTARTACKSOURCE

Diagnostic parameters

Diagnostic parameters	Variables	Default	Parameter
Function Active Status	-	-	AXIS#.SAFE.SOS.ACTIVE
Function Internal Status	-	-	AXIS#.SAFE.SOS.INTERNALSTATE

9.4.7.5 Timing

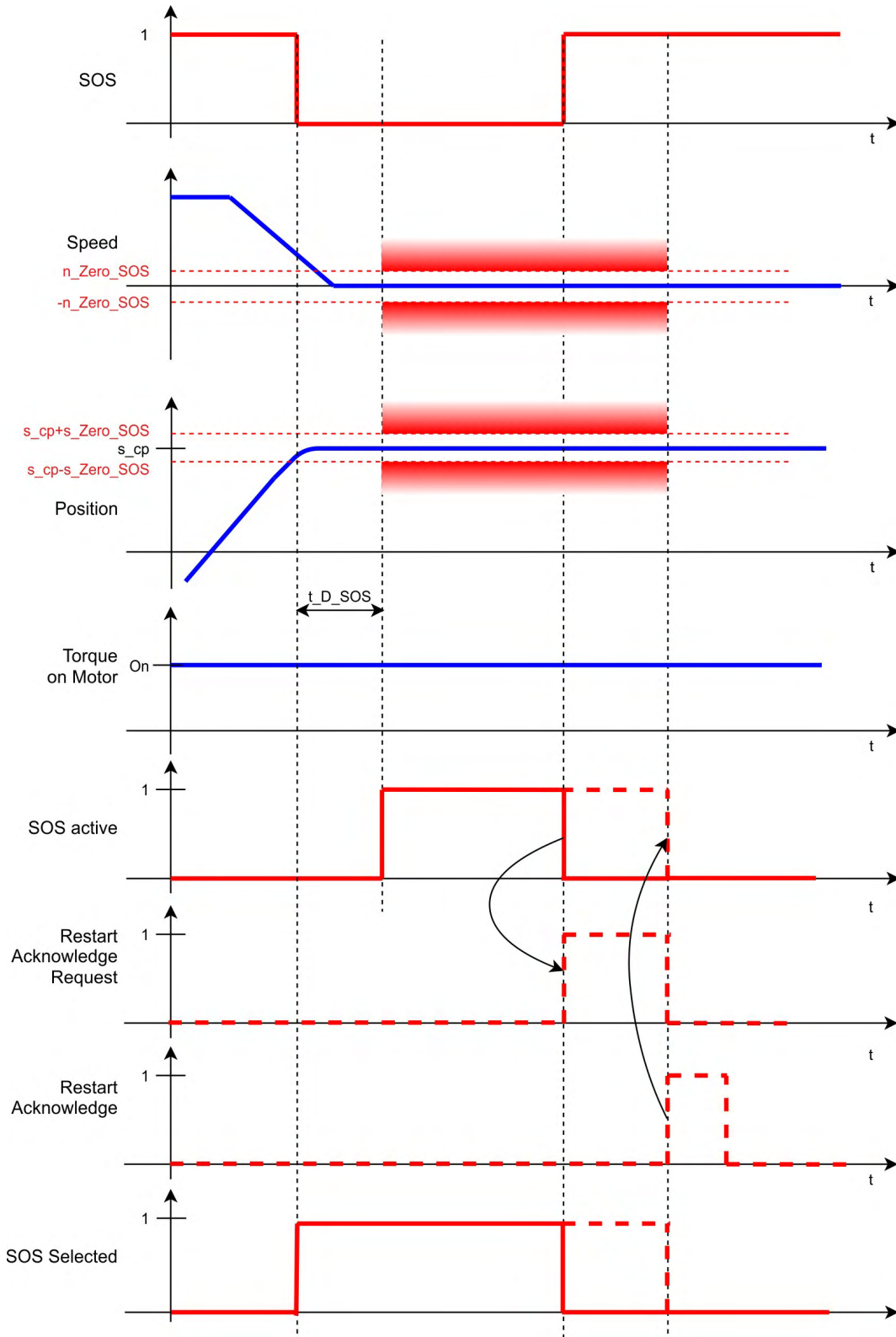

9.4.7.6 Setup in WorkBench

Select the drive and open the Safety Parameterization view (→ # 293).

Choose the axis (1), category (2), SOS function (3) and the instance number (4).



Parameters Editor

Configuration of the safety parameters.

[Learn more about this topic](#)

Axes	Categories	Safe Stop	Instances
Common	General	STO (Safe Torque Off)	Instance 1
Axis 1	Safe Stop	SS1 (Safe Stop 1)	
Axis 2	Safe Speed	SS2 (Safe Stop 2)	
	Safe Position	SOS (Safe Operating Stop)	
		SBC (Safe Brake Control)	
		SBT (Safe Brake Test)	
		SDB (Safe Dynamic Brake)	

[Goto Safety Parameter Download](#)

[SafeID: 1] Axis 1 > Safe Stop > SOS (Safe Operating Stop) > Instance 1



User Units (for information only)

Position: N/A

Velocity: N/A

Acceleration: N/A

Type: **Kollmorgen AKD2G SMM**
 Description: **Kollmorgen AKD2G SafeMotion Monitor**
 Import file: -

Parameter	Value	Unit
Axis 1 - Safe Stop - SOS - Instance 1		
Function Activation	Ready for Activation	
Safe Input	Not Used	
FSOE	Not Used	
Position Zero Window (s_Zero_SOS)	1	Position User Units
Velocity Monitoring	Disabled	
Velocity Zero Window (n_Zero_SOS)	0	Velocity User Units
Time Delay Monitoring (t_D_SOS)	1	ms
Restart Acknowledge Behavior	Automatic Restart	
Restart Acknowledge Source	Not used	

9.4.7.7 Fault Reaction / Failure Messages

The fault reaction of the SOS function is STO.

9.4.7.8 Safety State / Status Signals

The signal [AXIS#.SAFE.SOS_x.ACTIVE](#) can be monitored by safe digital outputs with OSSD pulses (→ # 212). The status signal must be mapped to the safe digital output. Two outputs can be combined to a dual channel output. For parameter description refer to (→ # 315).

9.4.7.9 Safety Properties

Refer to (Safety Properties Overview, → # 203).

9.4.8 SBC (Safe Brake Control)

Safe Brake Control description for drive option Functional Safety 2 or 3.

9.4.8.1 Description

The safety function SBC (Safe Brake Control) is used for controlling the brakes wired to X1, X2 or X4 of the AKD2G. The connected brake is engaged and released by switching both lines (BR+ and BR-).

- The safety function SBC makes a motor with a motor brake suitable for the usage scenarios A1, A2, E1, E2, E3 according to DGUV.
- The safety function SBC makes a motor with a motor brake and a second brake on the same axis suitable for the usage scenarios A1, A2, A3, E1, E2, E3 according to DGUV.
- The brake can be configured with or without (SDB (Safe Dynamic Brake), → # 255).
- For requirements to the motor brakes refer to (Motor Brake Requirements , → # 215).

Association of brake outputs to drive axes

Drive Type	Brake 1	Brake 2	max. SBC Safety Level
Single Axis	Axis 1 (X1)	Axis 1 (X4)	Axis 1 : SIL3 / PLe
Single Axis	Axis 1 (X1)	Not used	Axis 1 : SIL2 / PLd
Single Axis	Not used	Axis 1 (X1)	Axis 1 : SIL2 / PLd
Dual Axes	Axis 1 (X1)	Axis 2 (X2)	Axis 1 : SIL2 / PLd Axis 2: SIL2 / PLd
Dual Axes	Axis 1 (X1)	Axis 1 (X2)	Axis 1 : SIL3 / PLe Axis 2 : no brake

NOTE

To achieve SIL 3 / PLe for SBC,

- two brakes per axis must be used. With one brake the axis can reach SIL 2 / PLd only.
- the brake function must be tested periodically with SBT (→ # 249)

Important Notes

NOTICE

Hoist and crane support: The drive will safely ensure a holding position, as long as SBC (braking ramp, delay time) is configured correctly.

- Any brake must be connected to one of the SBC interfaces (X1, X2, X4).
- The user is responsible for the execution of the safe brake test SBT (→ # 249).

NOTE

For requirements to the motor brakes refer to (→ # 215).

Function Input / Output Variables

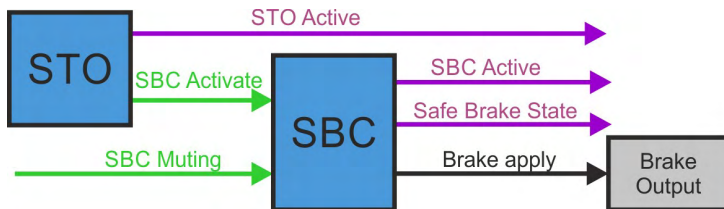

Inputs

- **SBC Delay:** brake delay tSBC
- **SBC Muting:**
 - can be used for enabling manual override of the brakes while STO is active.
 - muting can be activated by FSoE or safe digital inputs (must be mapped).
- **SBC Activate:**

- can be triggered by STO only without delay.
- the trigger with delay depends on the configuration, with/without SDB.

Outputs

- **SBC Active:** logical status of the SBC function
- **Safe Brake State:** state of the brake outputs (24V or 0V)

Number of Instances

One instance per axis.

9.4.8.2 Test Pulses

Test pulses are applied to the Brake+ and Brake- outputs (X1, X2, X4) alternately to ensure valid feedback. The test pulses are 1ms at the bottom but are 3ms long due to their slow edges.

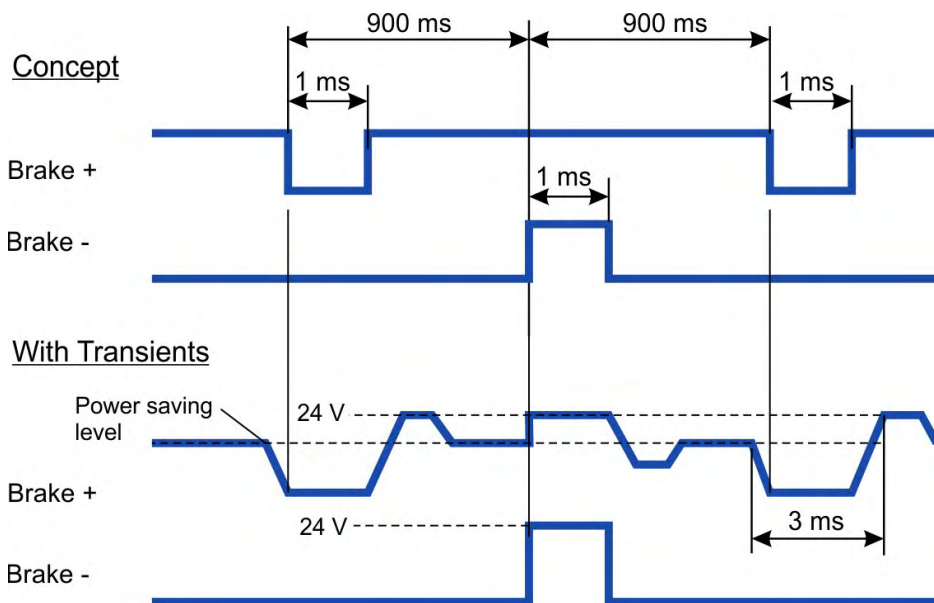

9.4.8.3 Activation

SBC for one or two brakes can be configured to be activated during STO process.

The controlled brake(s) can be configured to be engaged while motor torque is available (STO not active yet) or with STO became active (no motor torque).

NOTE

The safety function can be configured with WorkBench or via FSoE.

Example:

STO activated by safe digital inputs, one axis, SIL3 PLe, SBC with two brakes, SBT, without SDB

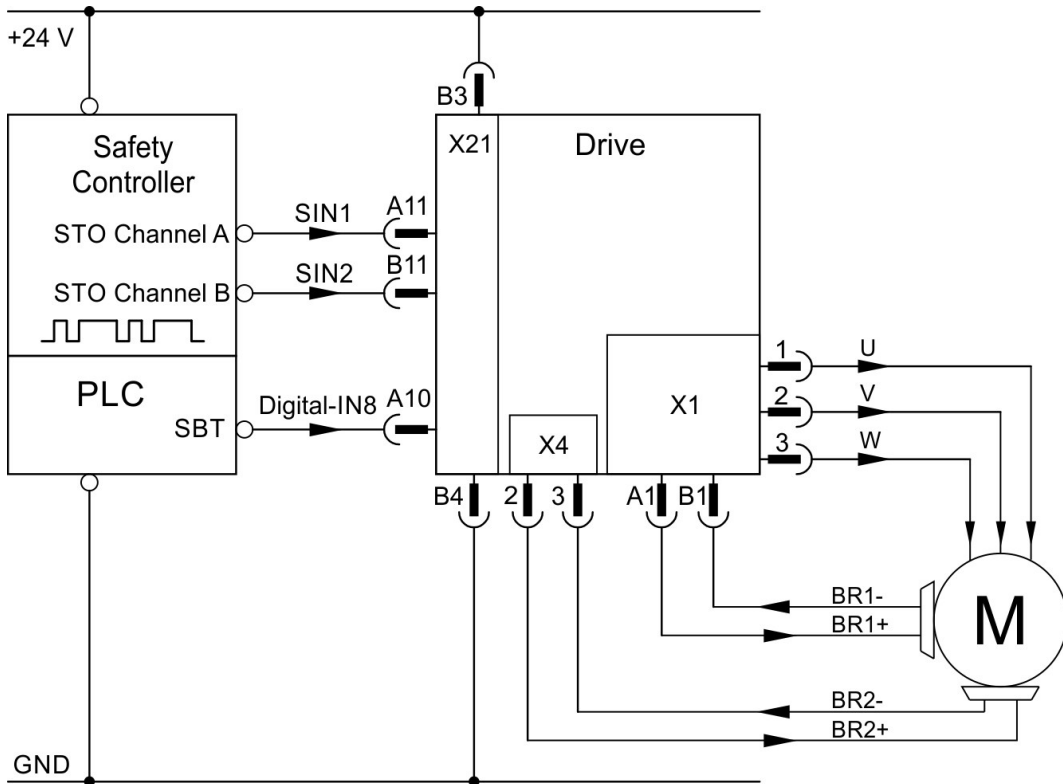

9.4.8.4 Restart

The brakes controlled by SBC will disengage simultaneously with the deactivation of STO if [AXIS#.SAFE.STO.REPORTFAULT](#) is set to 0.

If [AXIS#.SAFE.STO.REPORTFAULT](#) is set to 1, the brake will release when the axis is enabled again. See STO (→ # 221).

9.4.8.5 SBC Muting Function

NOTICE

SBC muting is critical with regards to safety and has important influence on the safety level of an application. It has to be ensured that the use of SBC muting has no negative impact on the required safety level within the complete operational range of the application. The reliability has to be independent from the application.

Consult your notified body for further information and approval.

For servicing purposes, manual control of the brakes may be necessary.

When SBC muting is active, the brakes can be overwritten even if STO/SBC is active. The SBC active signal will be suppressed and manual control via WorkBench, digital input or EtherCAT is possible.

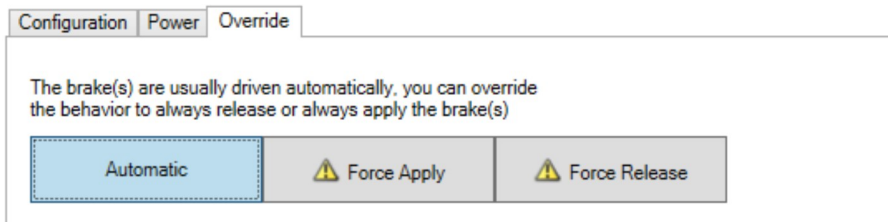

Manual control of the brakes is prohibited when SBC muting is not active and STO/SBC is active at the same time.

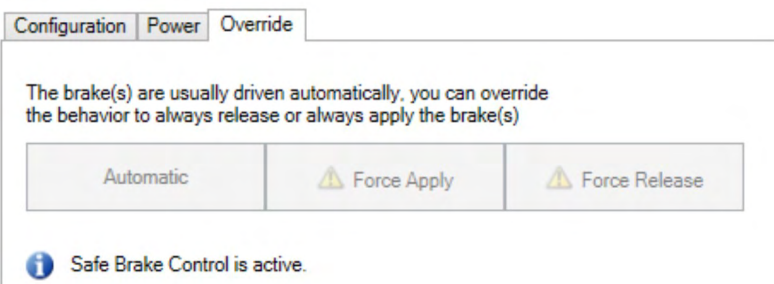

NOTICE

Overwriting the brake(s) behavior may create unsafe situations and/or damage.

If the axis is used for a vertical load, forcing the brake(s) to release may damage the load.

- Only use this function when safety is ensured by other measures.
- Deactivate SBC Muting before reentering normal operation.

If SBC Muting is active during STO activation and brake control is set to "automatic", brake behavior is determined by standard brake parameters.

Safety parameters

Name	Variables	Default	Parameter
SBC Brake 1	-	0	(→ # 400)
SBC Brake 2	-	0	(→ # 400)
Brake Delay	tSBC	100 ms	(→ # 399)
SBC Muting	-	0	(→ # 401)

Diagnostic parameters

Name	Variables	Default	Parameter
Function Active Status	-	-	(→ # 350)
Safe Brake State	-	-	(→ # 331)

Device parameters

Name			
BRAKEx.AXIS	For device parameters refer to WorkBench online help.		
AXISx.MOTOR.BRAKE			

9.4.8.6 Timing: SS1 followed by SBC without SDB

Process:

1. STO is requested.
2. The brake output is deactivated.
3. The system activates STO after the configured brake delay elapsed.

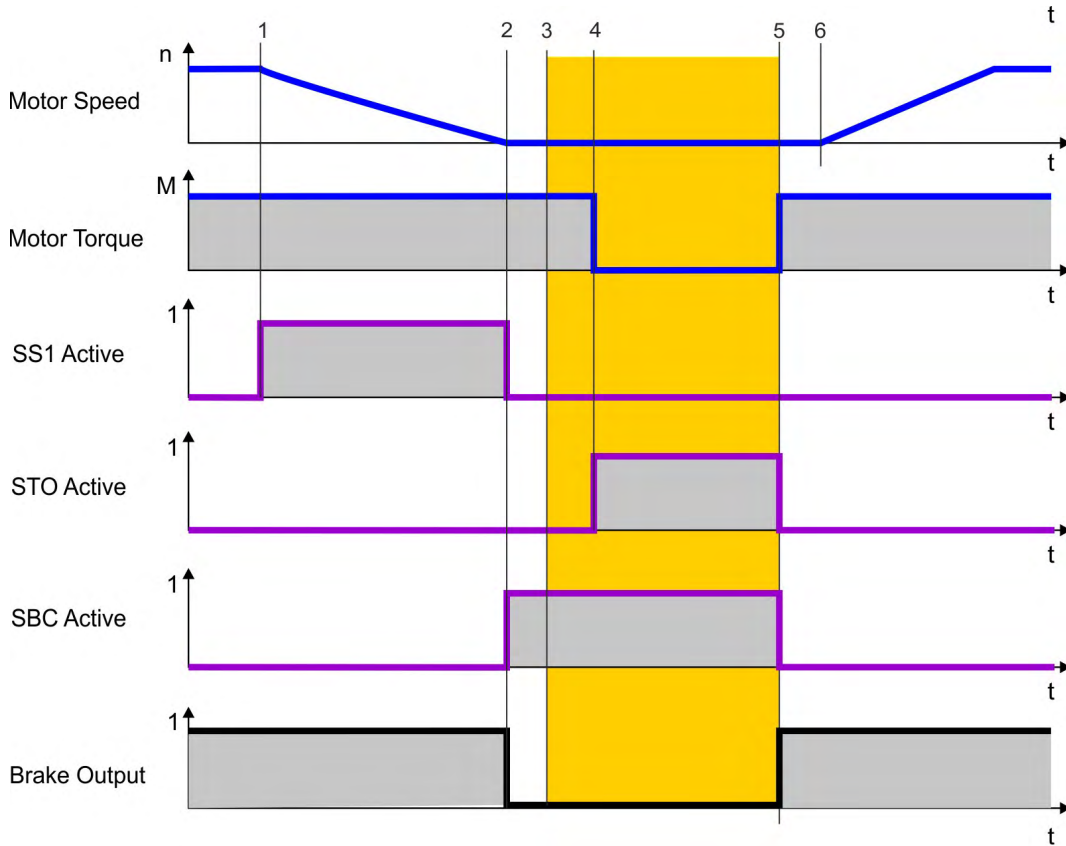

Timing	Max.	Remarks
t1		SS1 activate
t1 to t2	configurable	t _{SS1} : Time window for deceleration
t2		SBC activate brake output 0V
t2 to t3	see brake datasheet	Brake engaging
t3		Brake is applied
t2 to t4	configurable	t _{SBC} : Brake time delay
t4		STO activate
t5		STO, SBC deactivate, Brake output 24V
t5 to t6	see brake datasheet	Brake disengaging
t6		Brake is released

9.4.8.7 Timing: SS1 followed by SBC with SDB

Process:

1. STO is requested.
2. The brake output and the output power stage are deactivated simultaneously.

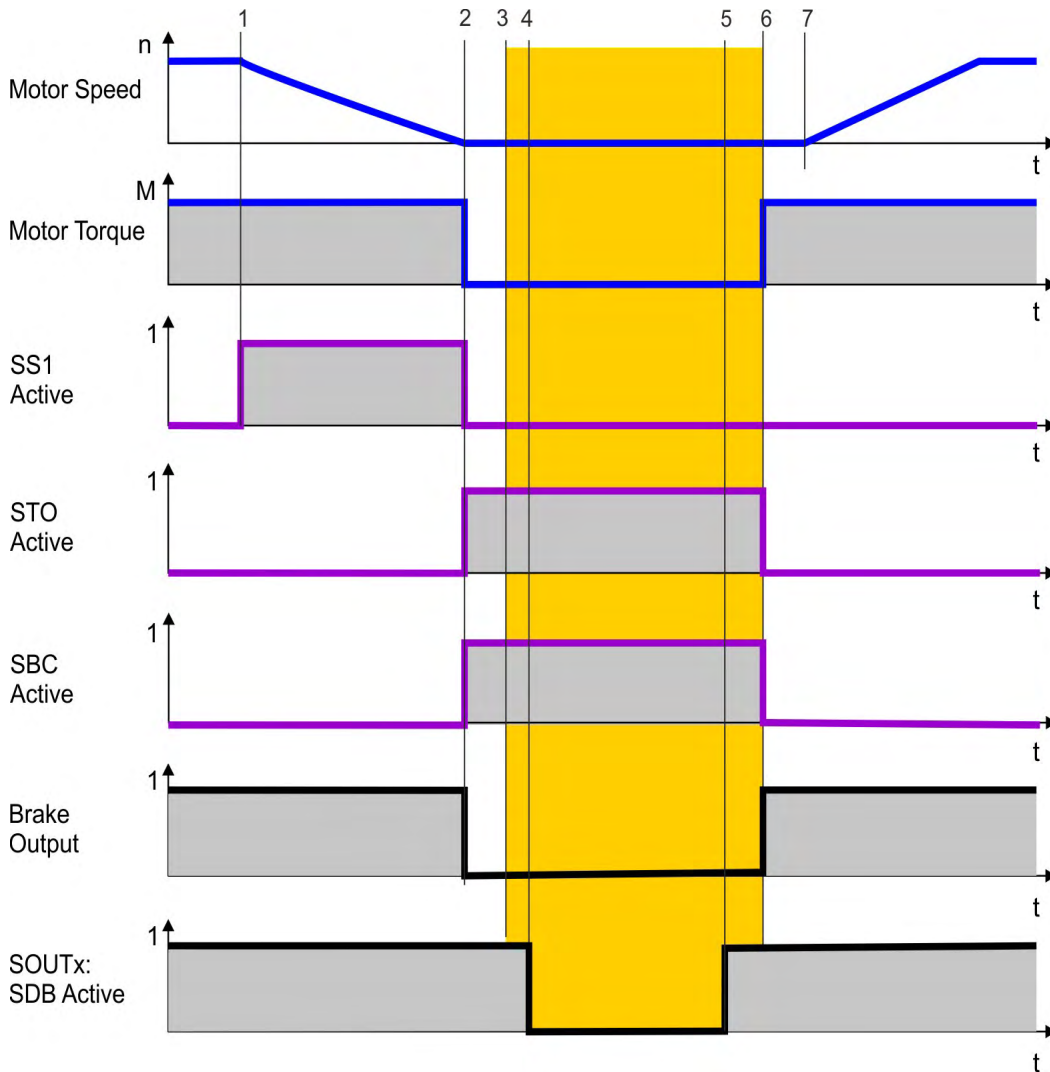

Timing	Max.	Remarks
t1		SS1 activate
t1 to t2	configurable	t_SS1: Time window for deceleration
t2		SBC activate. Brake output 0V
t2 to t3	see brake datasheet	Brake engaging
t3		Brake is applied
t2 to t4	fixed	Delay of 6ms
t5		SDB active. SOUTx active
t5 to t6	fixed	Delay of 6ms
t6		STO and SBC deactivates
t6 to t7	see brake datasheet	Brake disengaging
t7		Brake is released

Note: tSBC is not used in case SDB is configured.

9.4.8.8 Setup in WorkBench

Select Safety Parameterization view (→ # 291). Choose the axis (1), category (2) and SBC function (3). The instance number (4) is not applicable for SBC.



Parameters Editor

Configuration of the safety parameters.

[Learn more about this topic](#)

Axes	Categories	Safe Stop	Instances
Common	General	STO (Safe Torque Off)	Instance 1
Axis 1	Safe Stop	SS1 (Safe Stop 1)	
Axis 2	Safe Speed	SS2 (Safe Stop 2)	
	Safe Position	SOS (Safe Operating Stop)	
		SBC (Safe Brake Control)	
		SBT (Safe Brake Test)	
		SDB (Safe Dynamic Brake)	

[Goto Safety Parameter Download](#)

[SafeID: 1] Axis 1 > Safe Stop > SBC (Safe Brake Control) > Instance 1

Type: **Kollmorgen AKD2G SMM**
 Description: **Kollmorgen AKD2G SafeMotion Monitor**
 Import file: -

Parameter	Value	Unit
Axis 1 - Safe Stop - SBC - Instance 1		
SBC Brake 1	Configured without SDB	
SBC Brake 2	Configured with SDB	
Brake Time Delay (tSBC)	100	ms
SBC Muting	Not Used	

Validation Results (0)

Device Related Parameters (3)

Brake 1 used by: 1 - Axis 1 5

Brake 2 used by: 2 - Axis 2 6

Axis 1 Brake(s): 0 - Not Used 7

Each brake needs to be assigned to its controlling axis with the device related parameters:

Assigne the axis for Brake1 (5), assigne the axis for Brake2 (6).

(7) indicates whether the drive has detected a brake for the corresponding axis.

NOTICE

The device related parameter settings are not safe. Changing the configuration in this view will affect the device related parameters.

If the configuration collides with the safe settings, warning 9007 will be issued when the axis is disabled. Enabling the affected axis will be prohibited in this case.

On single axis drives, axis 1 can be configured to control brake 1 and 2 with SBC. For dual axis drives, the brake configuration must be considered:

Assignment	Axis#	Brake1	Brake2	Comment
Example 1	Axis1	SBC	SBC	If both brakes are assigned to axis1, axis2 cannot control any of those two brakes.
	Axis2	-	-	
Example 2	Axis1	SBC	-	If axis1 controls brake1 with SBC, axis2 can control brake2 with SBC.
	Axis2	-	SBC	
Example 3	Axis1	-	-	If both brakes are assigned to axis2, only brake2 can be controlled with SBC. Brake1 will be controlled, but not safe (no SBC).
	Axis2	no SBC	SBC	

9.4.8.9 Fault Reaction / Failure Messages

It is not possible to detect a malfunctioning brake through SBC. Therefore diagnosis with SBT is necessary in regular time intervals (see (SBT (Safe Brake Test), → # 249)).

A disconnected brake or an open circuit on the brake connectors (X1, X2 or X4) will result in an I/O failure causing SS1_1 (fault reaction) to be triggered followed by STO.

An I/O failure warning is issued when the AKD2G is disabled.

A fault will be issued when the AKD2G is enabled and [AXIS#.SAFE.STO.REPORTFAULT](#) is set to 1.

9.4.8.10 Safety State / Status Signals

See Fault reaction/Failure messages in chapter (SBT (Safe Brake Test), → # 249)

9.4.8.11 Safety Properties

Refer to (Safety Properties Overview, → # 203).

9.4.9 SBT (Safe Brake Test)

Safe Brake Test description for drive option Functional Safety 2 or 3.

9.4.9.1 Description

The function SBT (Safe Brake Test) can be used for testing the brakes connected to X1, X2 or X4 of the AKD2G. SBT is carried out by applying a configured torque against the closed brake and supervising the motion on the connected axis. The test is successful if the axis motion does not exceed a parameterized tolerance. If the axis motion exceeds the tolerance, the test is failed and therefore the safety functions using the brake are lost. After a failed brake test, safe brake operation cannot be assumed anymore. Brake replacement or service will be necessary.

- SBT is a diagnostic function for holding brakes. In order to operate brakes (SBC) that are part of a safety function (PLd / SIL2 or higher), frequent tests with SBT are required.
- SBT must be triggered regularly by the end customer.
- SBT considers the derating factor for brakes used in safety functions.
- During SBT, 130% of the max. possible application torque will be applied to the brake. Additional forces caused by vertical loads will be taken into account automatically.
- Brake slippage will be detected with a resolution of at least 1°.
- Two brakes can be assigned to one axis. Each brake can be configured with an independent slippage tolerance.
- SBT is only functional with SBC.
- SBT does not lead to wear of the brakes.

Important Notes

NOTICE

- The user is responsible for the trigger of the SBT function.
- For correct operation of SBT the axis must be free to move when the drive releases the brake or releases both brakes as appropriate; if the machine has further motors and/or brakes mechanically coupled to the same axis, these devices must be set to states where they do not impede motion before SBT is carried out. In this case only one brake shall be tested at a time. Each brake must be tested independently.
- The machine manufacturer has to determine the SIL / PL reached by SBC + SBT according to the configuration and parameterization.

NOTICE

When using external position command/PLC

At the end of SBT there is a mismatch between the set command value and the current position value of the axis. It is important that the master PLC executes an alignment of the set command position and the current axis position before SBT finishes to avoid a jump of the axis.

Execute a brake test

- at least every 8 hours,
- at the start of a machine or at the transition to operation mode using the brake,
- after long standstill of the machine,
- after drive reboot,
- after brake service or replacement.

Depending on the target SIL / PL of the safety function that is performed by the brakes, it can be necessary to carry out SBT more often. In high safety demand applications (SIL3 / PLe, DC = high), it can be necessary to execute SBT every time prior to demand. For example if access to a dangerous area is prohibited by a safety interlock, SBT must be executed successfully before access can be granted.

Restrictions

The maximum motion for the brake during safe brake test (see “Maximum Motion” parameters (Related Parameters, → # 251)) cannot be set to a greater or equal value than 10800 arcminute. Otherwise, the SMM will return an error code once SBT function is started. The error code can be read by the keyword [AXIS#.SAFE.SBT.ERROR](#), which will report “0x6 - SMM System Error”.

In general, it is expected to set the maximum motion for the “tested” brake as small as possible to prevent any mechanical hazards when the brake loses its holding function. However, an application might need a larger tolerance window because of a mechanical gearing between encoder and motor shaft.

The maximum slippage velocity in [RPM] is calculated by:

$$(10800 [\text{arcmin}] - \text{“Max. Motion”} [\text{arcmin}]) * 600 / 216$$

Example:

- For “Max. Motion” = 300 arcmin (5°), the max. slippage velocity is $(10800-300) * 600/216 = 29167$ rpm.
- For “Max. Motion” = 7200 arcmin (120°), the max. slippage velocity is $(10800-7200) * 600/216 = 10000$ rpm.

NOTE

The user has to consider for his application the worst case max. acceleration of motor shafts load including the additional "applied" test torque of the drive during SBT.

Preconditions for a brake test:

- The motor is at standstill.
- The tested brake is released.
- The drive is enabled.
- STO is not active.

Encoder requirements

NOTE

The encoder verification is not required for safe encoders that can be configured on drives with option FS3.

The SBT function can be executed with any encoder type. However, the encoder shall have at least a resolution and accuracy of 1 degree.

Encoder verification:

The user shall verify that the encoder works properly by his application. As example the following types of machine motion can be used to verify the function of the encoder:

- Perform a home move which includes a physical motion.
- A position move of at least 1 mechanical revolution of the encoder.
- A relative move to reach the start position of SBT.

After a long downtime of the machine, the encoder verification shall be repeated.

Current measurement verification

The verification check of drive current measurement should be done during machine commissioning and during re-commissioning due to changes such as replacement of the drive or firmware update.

The current measurement should verify expected current reported by the drive when holding a reference load. A small movement may be needed to overcome static friction.

Function Input / Output Variables



Inputs

- **SBT Activate** can be activated by
 - EtherCAT, CANopen
 - Digital input (must be mapped)
 - WorkBench

Outputs

- **SBA State**: logical status providing information on SBT. Can be mapped to a safe output and retrieved through FSoE status word.
0 = SBT execution necessary or failed in last attempt
1 = SBT was executed successfully within the parameterized period
- **SBT State**: for status information on the actual brake condition see (AXIS#.SAFE.SBT.STATE, → # 354).

Number of Instances

One instance per axis.

9.4.9.2 Activation

- By a non safe fieldbus: EtherCAT or CANopen SDO
- By a non safe digital input (DIGITAL-IN1 to DIGITAL-IN12, (→ # 166)).
- By WorkBench

9.4.9.3 Related Parameters

Safety parameters

Name	Variables	Default	Parameter
Function Activation	-	0 (Never active)	(→ # 402)
Maximum Time Interval	-	480 min	(→ # 405)
Max Application Load	-	1000 mA	(→ # 403)
Maximum Motion 1st Attached Brake	-	300 arcmin	(→ # 404)
Maximum Motion 2nd Attached Brake	-	300 arcmin	(→ # 404)
Torque Duration	-	500 ms	(→ # 406)

Diagnostic parameters

Name	Variables	Default	Parameter
SBT Actual Status	-	-	(→ # 354)
SBT Move	-	-	(→ # 352)
SBT SBA Active	-	-	(→ # 353)
SBT Error	-	-	(→ # 351)
Brake SBT Elapsed	-	-	(→ # 507)
Brake SBT State	-	-	(→ # 508)

9.4.9.4 Timing

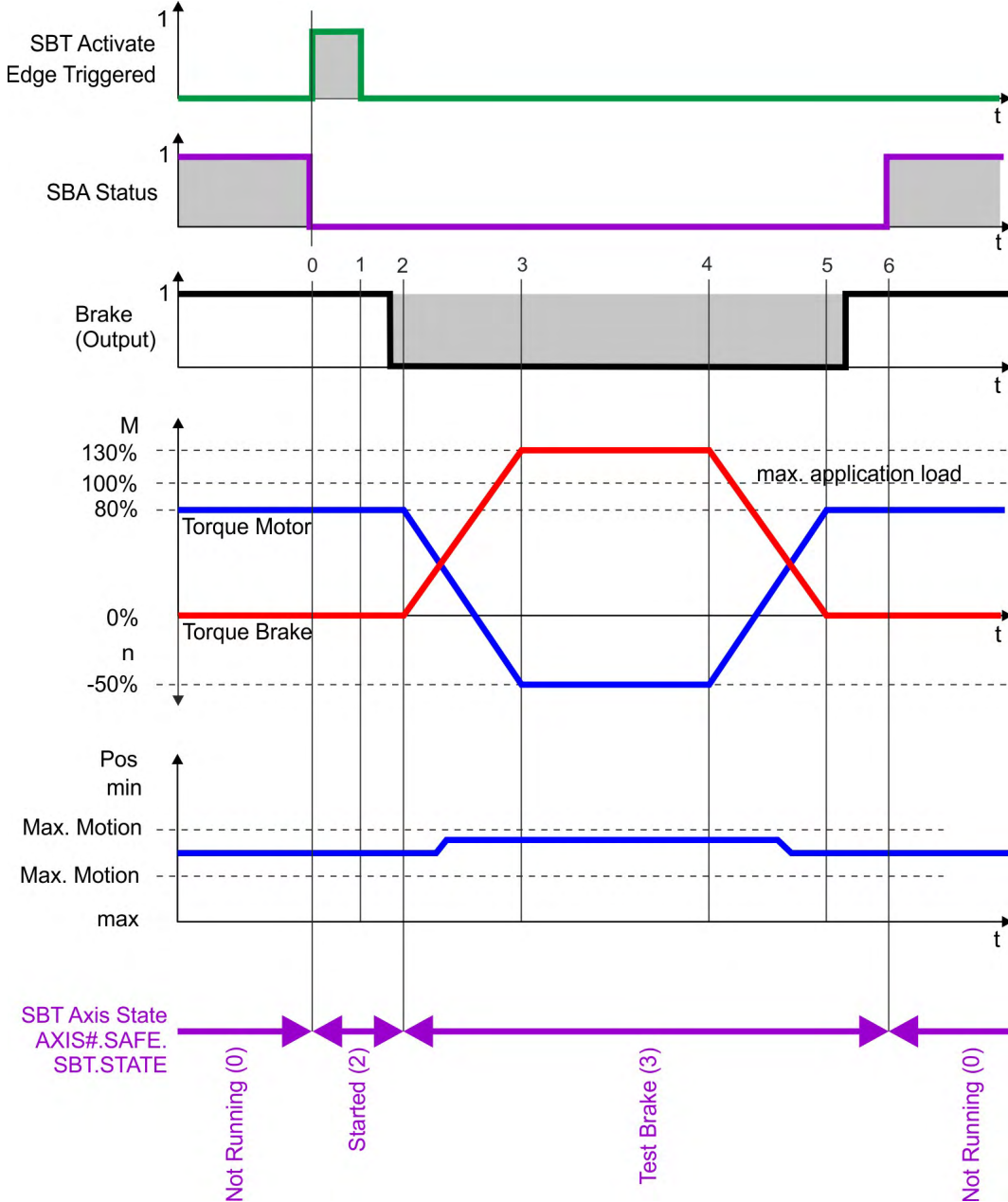

Timing	max	Remarks
t0		Start SBT
t0 to t1	200 ms	Measuring actual application load on motor
t1 to t2	300 ms	Brake applies
t2		Brake is applied. Position monitoring is started. Drive is switched to torque mode internally.
t2 to t3	$1/3 * (t3 \text{ to } t4)$	Ramp-up to apply 130% torque on the brake
t3 to t4	Configurable	Torque duration
t4 to t5	$1/3 * (t3 \text{ to } t4)$	Ramp-down torque on the brake
t5 to t6	300 ms	Release brake
t6 to t0	Configurable	Maximum time interval between tests

9.4.9.5 Setup in WorkBench

Select Safety Parameterization view (→ # 291).

Choose the axis (1), category (2) and SBT function (3). The instance number (4) is not applicable for SBT.

Parameters Editor [Learn more about this topic](#)

Configuration of the safety parameters.

Common	Categories	Safe Stop	Instances
Axis 1	General	STO (Safe Torque Off)	Instance 1
Axis 2	Safe Stop	SS1 (Safe Stop 1)	
	Safe Speed	SS2 (Safe Stop 2)	
	Safe Pos	SOS (Sa...erating Stop)	
		SBC (Safe Brake Control)	
		SBT (Safe Brake Test)	
		SDB (Safe Dynamic Brake)	

[Goto Safety Parameter Download](#)

[SafeID: 1] Axis 1 > Safe Stop > SBT (Safe Brake Test) > Instance 1

Type: **Kollmorgen AKD2G SMM**
 Description: **Kollmorgen AKD2G SafeMotion Monitor**
 Import file: -

Parameter	Value	Unit
Axis 1 - Safe Stop - SBT - Instance 1		
Function Activation	Ready for Activation	
Maximum Time Interval	480	minute
Max Application Load	1000	mA
Maximum Motion Brake 1	300	arcmin
Maximum Motion Brake 2	300	arcmin
Torque Duration	500	ms

9.4.9.6 Fault Reaction / Failure Messages

If not all the preconditions are fulfilled and SBT is requested, the SBT button will be grayed out:

(B) Safe Brake Test
 Safe brake test activation and monitoring.

Axis 1

Brake Test Enabled: 1 - Ready for Activation

Max Time Between Test: hh:mm:ss

Brake Test State: 0 - Not running

Brake Test Error: 0 - No error

When a brake test fails, further operation shall be prohibited by means of an external safe PLC. SBA will remain 0 and the Safety Diagnostics will show a "Brake Slippage Occurred":

Axis 2

Brake Test Enabled: 1 - Ready for Activation

Max Time Between Test: hh:mm:ss

Brake Test State: 0 - Not running

Brake Test Error: 6 - Brake slippage occurred

A controlled stop will be executed immediately when a brake slippage is detected during the brake test. The drive remains enabled.

9.4.9.7 Safety State / Status Signals

Status of each axis and the assigned brakes can be observed in the SBT diagnostics view.

B

Safe Brake Test

Safe brake test activation and monitoring.

Axis 1

Brake Test Enabled: 1 - Ready for Activation

Max Time Between Test: 00:10:00 hh:mm:ss

Brake Test State: 0 - Not running

Brake Test Error: 0 - No error

Start Brake Test

Brake 1

State: 0 - Not tested

Time Remaining Until Next Check: 00:09:39 hh:mm:ss

The view gives information about:

- Status, if the test is running or not
- Test result (Not tested, Failed, Passed)
- Time until next and in-between test
- Status information on the test, if and which error occurred

If a brake test is not executed within the parameterized time interval, the Safe Brake Test Diagnostics will inform that the test validity is expired.

Time Remaining Until Next Check:

00:00:00

hh:mm:ss

⚠ Test validity expired!

The warning 9008 “Brake Test Time Overflow” will be issued.

Axis (1): ✖ **1 Fault(s)** ⚠ **1 Warning(s)**

Disable & Clear Faults
✖

Axis	Type	Group	Id	Description	Details
1	✖	Safety	9000	Safe torque off.	Help
1	⚠	Safety	9008	Warning: Brake Test Time Overflow.	Help

Disable Fault auto popup.
 Disable Warning auto popup.

Copy

9.4.10 SDB (Safe Dynamic Brake)

Safe Dynamic Brake description for drive option Functional Safety 2 or 3.

9.4.10.1 Description

If the motor brake allows standstill braking only, dynamic braking is a method to slow down a servo system by dissipating the mechanical energy driven by the motor back EMF. When activated, the optional external Safe Dynamic Brake Contactor shortens the motor terminals. This forces all of the dynamic braking current to be stopping current. While the lines to the motor are shorted, the SDB status signal will be applied. When configured, SDB gets executed simultaneously along with STO.

Use this function when operating with high inertia loads.

Important Notes



WARNING No Brake Power at and near standstill!

Serious injury could result when the load is not properly blocked. This function does not ensure functional safety.

- Add a safe mechanical blocking (for instance, a motor holding brake).
- Configure (SBC (Safe Brake Control), → # 240) to be used with SDB.

NOTICE

- If SDB function is active, it is not possible to perform a controlled stop according to IEC 60204-1 category 1. If controlled stop category 1 is necessary, use the SS1 function.
- A failure in the SDB-Contactor can only be detected when changing states. In order to detect a loss of the safety function, SDB (STO) needs to be activated regularly according to the SIL/PL of the safety function.
- The SDB-Contactor is a safety related electromechanical component. The frequency of use contributes to its PFH value and therefore to the whole safety chain.
- Activating the SDB-Contactor (0V, closing contacts) will result in a short circuit on the output stage which could impair the drive when enabled. Therefore pay close attention to the parameterized timings especially during restart. Keep in mind the mechanical reaction time of the SDB-Contactor for activation and deactivation.
- Brake power depends on the inertia and speed of the decelerated mass. Activating SDB when the motion contains high amounts of energy can result in a very fast stop or very high currents. The braking energy and therefore the braking speed can be limited by external resistors.
- For assistance with determining stopping time and braking current when using the SDB function of the AKD2G refer to the online [AKD2G Safe Dynamic Braking Tool](#) or contact Kollmorgen technical support.

Function Input / Output Variables



Inputs

- **STO Active:** refer to (STO (Safe Torque Off), → # 219)
- **SDB Readback:** input for diagnosis signal returning from the SDB-Contactor

Outputs

- **SDB Activate:** signal for activating the SDB-Contactor auxiliary contacts

Number of Instances

One instance per axis.

9.4.10.2 Activation

SDB can be configured to be activated during the STO process. The SDB-Contactor function must be supervised using the status path. AKD2G can supply a signal with OSSD pulses to the SDB-Contactor (set SOUTx to "ON") for diagnosis. This OSSD signal can also be provided by the safe PLC. The SDB-Contactor output status is evaluated by the drive. Use [SDB.READBACKSOURCE](#) for mapping the safe input to the SDB status signal.

NOTICE The used SDB-Contactor must have a freewheeling diode in parallel to the coil. The braking energy can be limited using external resistors (Rext) limiting the back EMF current. Contact Kollmorgen Technical support for usable SDB-Contactors or component sizing.

Example: STO activated by safe inputs, SDB single channel, SIL2 PLd, SBC, SBT

Setting : SOUT1 = Activate SDB, SOUT2 = on, SIN3 = Readbacksource

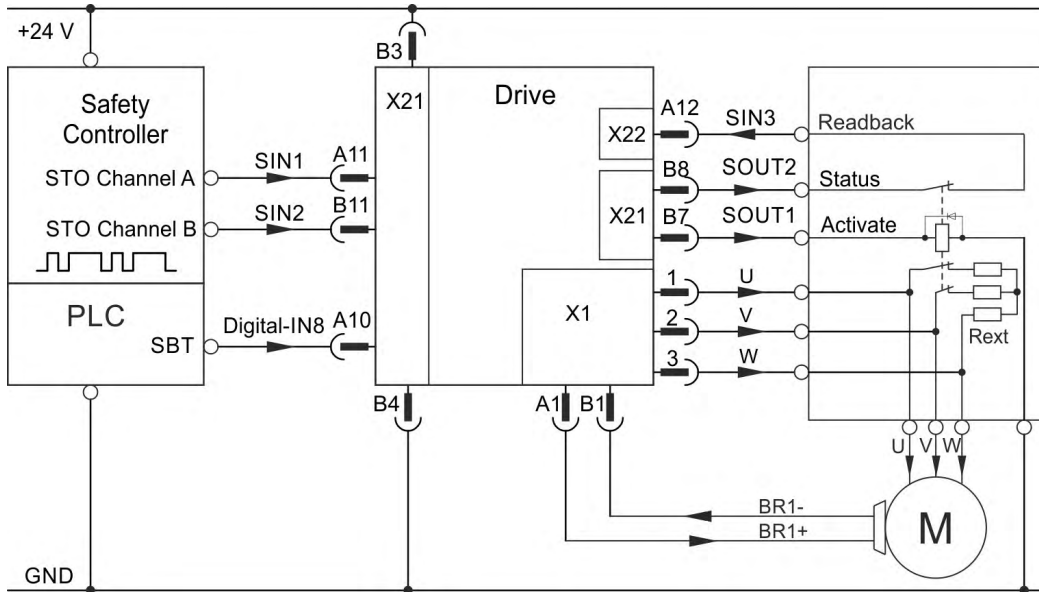

Example: STO activated by safe inputs, SDB dual channel, SIL3 Ple, SBC, SBT

Setting : SOUT1 = Activate SDB channel 1, SOUT2 = Activate SDB channel 2, SOUT3 = on, SIN3 = Readbacksource

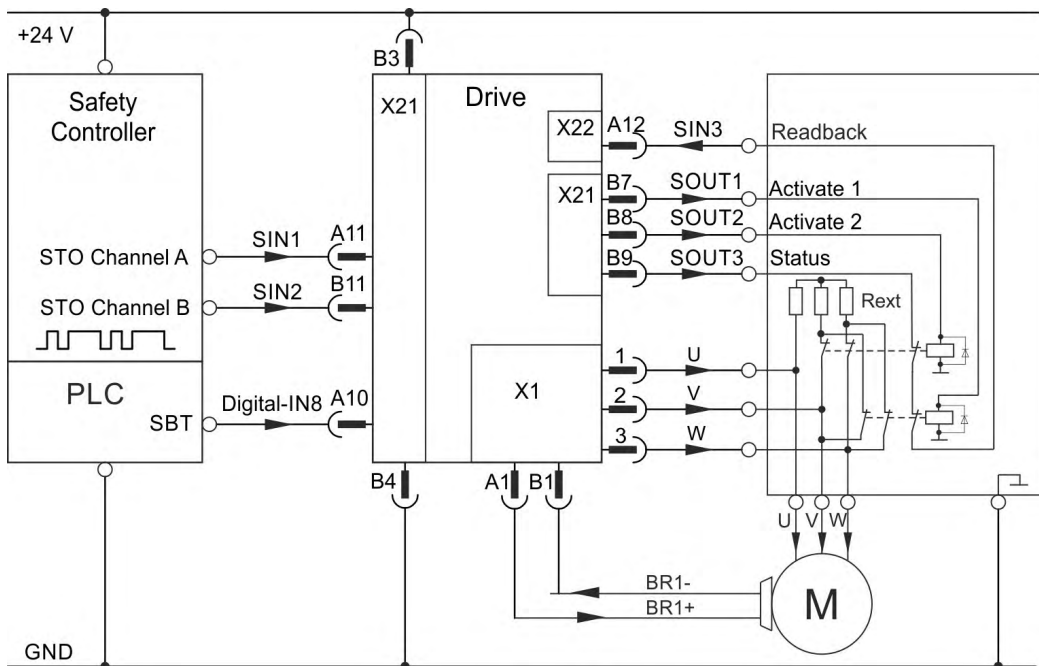

9.4.10.3 Restart

Refer to STO for restart conditions (Restart, → # 220). When all conditions for a STO restart are fulfilled and SDB is configured, the SDB-Contactor will be deactivated and the readback diagnosis will be disabled. After the configured delay (same as during SDB activation) the STO will disable, allowing torque. The readback diagnosis will reengage after the configured time.

9.4.10.4 Timing

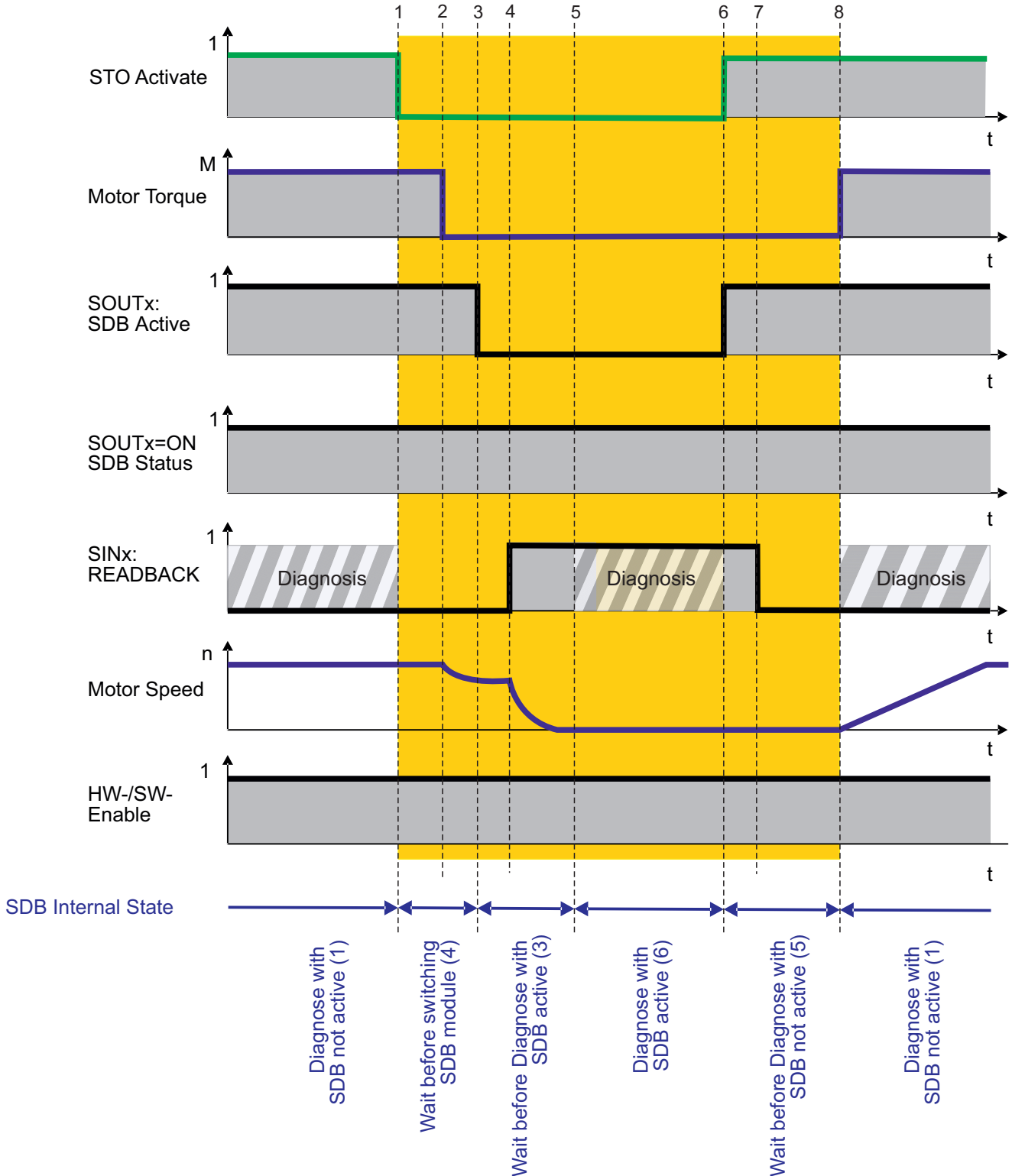

Timing	Max.	Remarks
t1 to t2	< 6 ms	STO response time

Timing	Max.	Remarks
t1 to t3	fixed	Delay of 6ms
t3 to t4	see datasheet	Mechanical delay SDB-Contactor
t3 to t5	configurable	t_D_SDB: Delay until readback diagnosis
t6 to t7	see datasheet	Mechanical delay SDB-Contactor
t6 to t8	configurable	t_D_SDB: Delay until readback diagnosis

9.4.10.5 Related Parameters

Name	Variables	Default	Parameter
Function Activation	-	0 (Never active)	(→ # 411)
Readback	-	Not Used	(→ # 412)
Delay Before Diagnose	t_D_SDB	1 ms	(→ # 1)

9.4.10.6 Setup in WorkBench

Select Safety Parameterization view (→ # 291).

Choose the axis (1), category (2) and SDB function (3).

Parameters Editor
Configuration of the safety parameters.

Learn more about this topic

Go to Safety Parameter Download

The screenshot shows a 'Parameters Editor' window with four panes: 'Axes', 'Categories', 'Safe Stop', and 'Instances'. In the 'Axes' pane, 'Axis 1' is selected and circled with a red '1'. In the 'Categories' pane, 'Safe Stop' is selected and circled with a red '2'. In the 'Safe Stop' pane, 'SDB (Safe Dynamic Brake)' is selected and circled with a red '3'. In the 'Instances' pane, 'Instance 1' is selected and circled with a red '4'.

[SafeID: 1] Axis 1 > Safe Stop > SDB (Safe Dynamic Brake) > Instance 1

Type: **Kollmorgen AKD2G SMM**
Description: **Kollmorgen AKD2G SafeMotion Monitor**
Import file: -

Parameter	Value	Unit
Axis 1 - Safe Stop - SDB - Instance 1		
Function Activation	Ready for Activation	
Readback	Safe input 3 (SIN3)	
Delay Before Switching (tSDB)	1	ms
Delay Before Diagnose (t_D_SDB)	1	ms

9.4.10.7 Fault Reaction / Failure Messages

The drive supervises the safe input(s) assigned as readback. An OSSD pulsed signal, either from a safe output or a safe PLC, is required. When the readback signal becomes static, an I/O error will be detected.

During the activation and deactivation of the SDB function, the readback diagnosis will be interrupted for the parameterized amount of time. When STO/SDB are active, a high signal (24V) is expected. When STO/SDB are not active, a low signal (0V) is expected. Deviating this expected behavior will additionally result in a SDB failure recognizable from the diagnostics view.



Diagnostics

Current status and configuration of the safe module monitor.

Identification / Validation

Safe ID:

System CRC:

Current State

System State:

Current Error:





For detailed information on the signal states refer to (→ # 257).

9.4.10.8 Safety State / Status Signals





The WorkBench view “Safety Diagnostics - Safe I/O” shows the current status of the safe inputs and outputs. The target status can be read of the assigned output(s). The status of the SDB readback can be read from the assigned input(s). Which state is appropriate depends on the system state.

 **Safe I/O**
 Current usage and values of the safe I/Os

Inputs

- SIN 1 
- SIN 2 
- SIN 3 
- SIN 4 

Outputs

SOUT 1 Source:	<input type="text" value="255 - On"/>	 SOUT 1
SOUT 2 Source:	<input type="text" value="255 - On"/>	 SOUT 2
SOUT 3 Source:	<input type="text" value="255 - On"/>	 SOUT 3
SOUT 4 Source:	<input type="text" value="59 - SDB - Axis 1"/>	 SOUT 4

For detailed information on the signal states refer to (→ # 257).

9.4.10.9 Safety Properties

Refer to (Safety Properties Overview, → # 203).

9.4.11 SLS (Safely Limited Speed)

SLS description for drive option Functional Safety 3.

9.4.11.1 Description

SLS, when activated, monitors the absolute velocity of the axis and ensures that it does not go above the configured limit. If it does, the function will activate a configurable fault reaction.

Once the activation request is received, SLS will become active, depending on whichever happens first:

- The time to velocity monitoring is elapsed (t_{SLS}).
- The minimum deceleration limit ramp hits the configured limit (n_{SLS}).
- The current velocity remains below the configured limit (n_{SLS}) for a given amount of time (t_{L_SLS}) (only when deceleration monitoring configured).
- Immediately, when the velocity is already below the configured limit (n_{SLS}) (only when deceleration monitoring not configured).

Optionally, the deceleration ramp could be monitored after some delay (t_{D_SLS}) checking that the actual velocity is below the computed velocity ramp (a_{SLS}). If the velocity is above the computed velocity ramp, SLS will activate the fault reaction.

Number of Instances

Three instances per axis.

Function Input / Output Variables

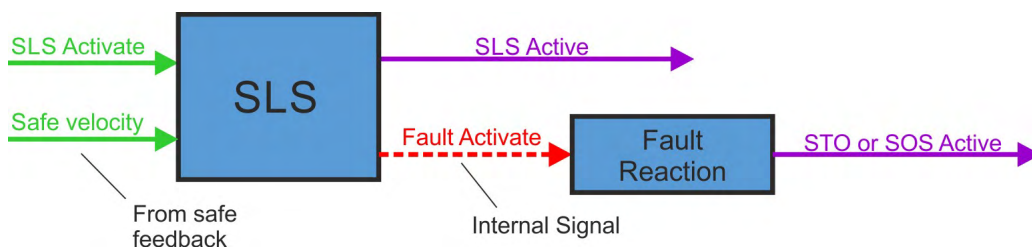

Inputs

- **SLS Activate** can be triggered by FSoE or safe digital inputs (must be mapped)
- **Safe velocity**: velocity signal from safe feedback

Outputs

- **SLS Active**: logical status of the SLS function
- **Fault Activate**: activate fault reaction

9.4.11.2 Activation

Activation by FSoE	<ul style="list-style-type: none"> • For a drive profile overview, see FSoE (FSoE, → # 213). • For setup and handling, see the <i>AKD2G EtherCAT Manual</i>.
Activation by safe digital inputs	<ul style="list-style-type: none"> • To review the enclosure and wiring instructions, see Enclosure, wiring (Enclosure, wiring, → # 198). • To see technical data for the safe inputs, see Technical Data (Technical Data, → # 210). • For notes on activation by safe inputs, see Activation by Safety Digital Inputs (Activation By Safe Digital Inputs, → # 205).

9.4.11.3 Timing

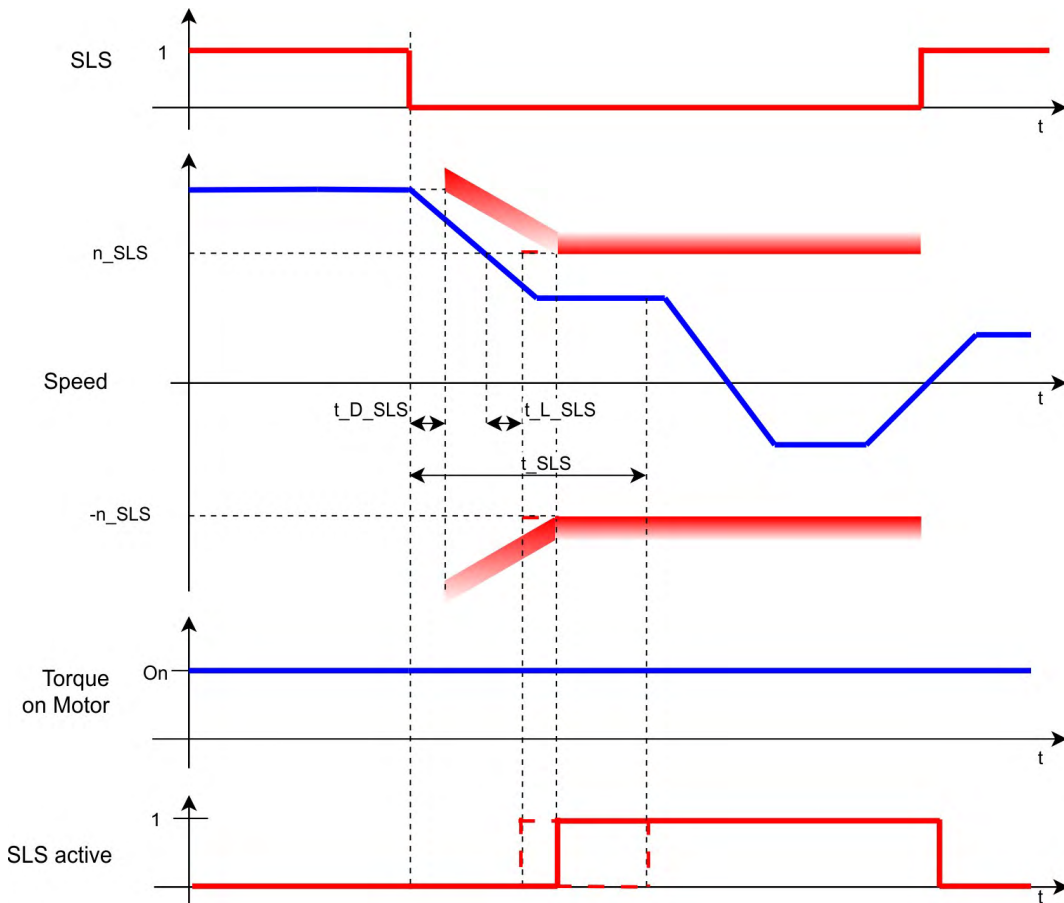

9.4.11.4 Related Parameters

Safety parameters

Name	Variables	Default	Parameter
Function Activation	-	0 (Never active)	(→ # 446)
Safe Input	-	0 (Not used)	(→ # 447)
FSOE	-	0 (Not used)	(→ # 445)
Time to Velocity Monitoring	t_{SLS}	2 ms	(→ # 450)
Velocity Limit	n_{SLS}	1 (Vel user units)	(→ # 451)
Time for Velocity in Limits	t_{L_SLS}	1 ms	(→ # 449)
Deceleration Monitoring	-	0 (Disabled)	(→ # 443)
Deceleration Limit	a_{SLS}	0 (Dec user units)	(→ # 442)
Time Delay Deceleration Monitoring	t_{D_SLS}	1 ms	(→ # 448)
Fault Reaction	-	1 (STO)	(→ # 444)

Diagnostic parameters

Name	Variables	Default	Parameter
Function Active Status	-	-	(→ # 367)
Function Internal Status	-	-	(→ # 368)

9.4.11.5 Setup in WorkBench

Select the drive and open the Safety Parameterization view (→ # 293).

Choose the axis (1), category (2), SLS function (3) and the instance number (4).



Parameters Editor

Configuration of the safety parameters.

[Learn more about this topic](#)

Axes	Categories	Safe Speed	Instances
Common	General	SLS (Safe Limited Speed)	Instance 1
Axis 1	Safe Stop	SSM (Safe Speed Monitor)	Instance 2
Axis 2	Safe Speed	SSR (Safe Speed Range)	Instance 3
	Safe Position	SDI (Safe Direction)	
1	2	SLA (Safe Limited Acceleration)	4
		SAR (Safe Acceleration Range)	

[Goto Safety Parameter Download](#)

[SafeID: 1] Axis 1 > Safe Speed > SLS (Safe Limited Speed) > Instance 1



User Units (for information only)

Position: N/A

Velocity: N/A

Acceleration: N/A

Type: **Kollmorgen AKD2G SMM**
 Description: **Kollmorgen AKD2G SafeMotion Monitor**
 Import file: -

Parameter	Value	Unit
Axis 1 - Safe Speed - SLS - Instance 1		
Function Activation	Ready for Activation	
Safe Input	Not Used	
FSoE	Not Used	
Time to Velocity Monitoring (t_SLS)	2	ms
Velocity Limit (n_SLS)	1	Velocity User Units
Time for Velocity in Limits (t_L_SLS)	1	ms
Deceleration Monitoring	Enabled	
Deceleration Limit (a_SLS)	0	Acceleration User Units
Time Delay Deceleration Monitoring (t_D_SLS)	1	ms
Fault Reaction	STO	

9.4.11.6 Fault Reaction / Failure Messages

SLS has a configurable fault reaction. STO is used by default but can be replaced by SS1 Instance 1 or SS2 Instance 1. When the fault reaction is activated, SLS remains active and the internal state ([AXIS#.SAFE.SLS_#.INTERNALSTATE](#)) is set to failed state (5).

9.4.11.7 Safety State / Status Signals

The signal [AXIS#.SAFE.SLS_#.ACTIVE](#) can be monitored by safe digital outputs with OSSD pulses (→ # 212). The status signal must be mapped to the safe digital output. Two outputs can be combined to a dual channel output. For parameter description refer to (→ # 315).

9.4.11.8 Safety Properties

Refer to (Safety Properties Overview, → # 203).

9.4.12 SSM (Safe Speed Monitor)

SSM description for drive option Functional Safety 3.

9.4.12.1 Description

SSM is a pure monitoring function which has no fault reaction. Once configured, it stays activated monitoring whether the velocity stays within a velocity window or not. The parameter n_UL_SSM defines the upper limit and the parameter n_LL_SSM defines the lower limit of this window.

The SSM function returns a logical status, called InRange, which tells whether the velocity is currently located in the velocity window or not.

Number of Instances

Two instances per axis.

Function Input / Output variables

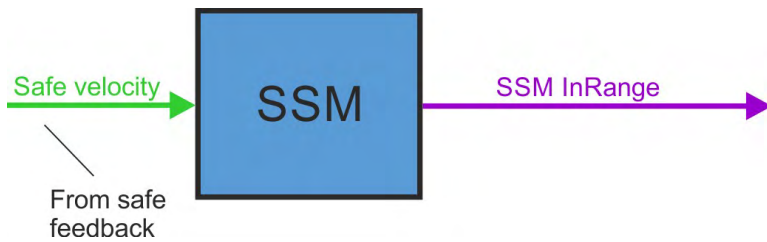

Input

- **Safe velocity:** velocity signal from safe feedback

Outputs

- **SSM InRange:** logical status telling if the velocity is in the range defined by the SSM function

9.4.12.2 Activation

No activation source. Once configured in the safety parameters, it stays activated.

9.4.12.3 Related Parameters

Safety parameters

Name	Variables	Default	Parameter
Function Activation	-	0 (Never active)	(→ # 476)
Velocity Upper Limit	n_UL_SSM	0 (Vel user units)	(→ # 478)
Velocity Lower Limit	n_LL_SSM	0 (Vel user units)	(→ # 477)

Diagnostic parameters

Name	Variables	Default	Parameter
SSM InRange	-	-	(→ # 378)
Function Internal Status	-	-	(→ # 379)

9.4.12.4 Timing

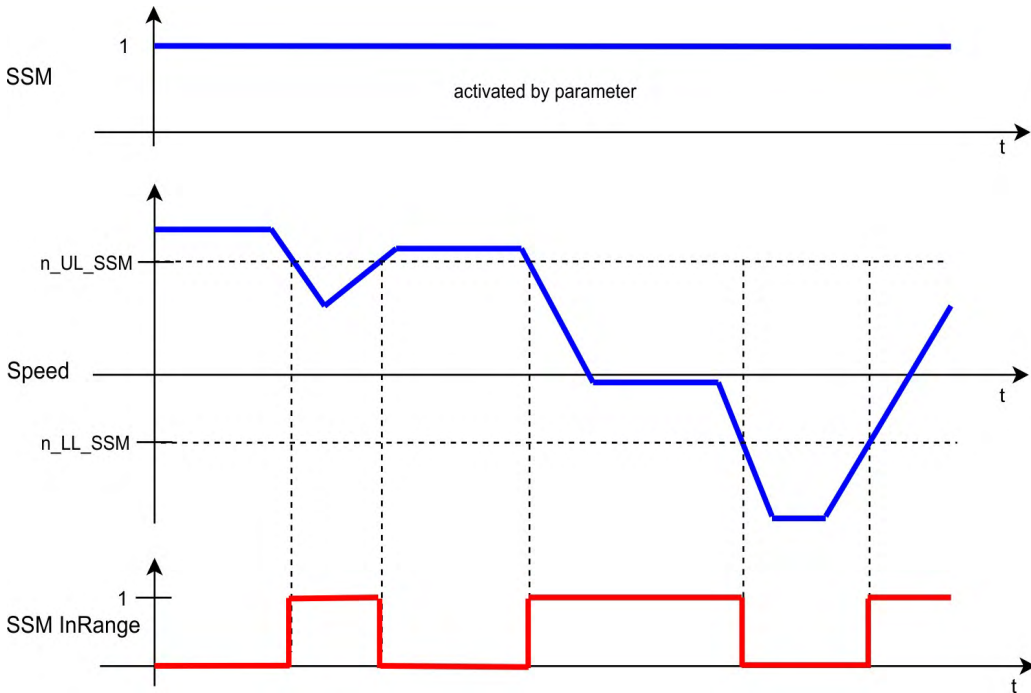

9.4.12.5 Setup in WorkBench

Select the drive and open the Safety Parameterization view (→ # 293).

Choose the axis (1), category (2), SSM function (3) and the instance number (4).



Parameters Editor

Configuration of the safety parameters.

[Learn more about this topic](#)

Axes	Categories	Safe Speed	Instances
Common	General	SLS (Safe Limited Speed)	Instance 1
Axis 1	Safe Stop	SSM (Safe Speed Monitor)	Instance 2
Axis 2	Safe Speed	SSR (Safe Speed Range)	
	Safe Position	SDI (Safe Direction)	
		SLA (Safe Limited Acceleration)	
		SAR (Safe Acceleration Range)	

[Goto Safety Parameter Download](#)

[SafeID: 1] Axis 1 > Safe Speed > SSM (Safe Speed Monitor) > Instance 1



User Units (for information only)

Position: N/A Velocity: N/A Acceleration: N/A

Type:	Kollmorgen AKD2G SMM		
Description:	Kollmorgen AKD2G SafeMotion Monitor		
Import file:	-		
Parameter	Value	Unit	
Axis 1 - Safe Speed - SSM - Instance 1			
Function Activation	Always Active		
Velocity Upper Limit(n_UL_SSM)	0	Velocity User Units	
Velocity Lower Limit (n_LL_SSM)	0	Velocity User Units	

9.4.12.6 Safety State / Status Signals

The signal [AXIS#.SAFE.SSM #.INRANGE](#) can be monitored by safe digital outputs with OSSD pulses (→ # 212). The status signal must be mapped to the safe digital output. Two outputs can be combined to a dual channel output. For parameter description refer to (→ # 315).

9.4.12.7 Safety Properties

Refer to (Safety Properties Overview, → # 203).

9.4.13 SSR (Safe Speed Range)

SSR description for drive option Functional Safety 3.

9.4.13.1 Description

SSR, when activated, monitors the velocity and ensures that it stays in a configured velocity window. The parameter n_UL_SSR defines the upper limit and the parameter n_LL_SSR defines the lower limit of this window. If the velocity leaves the velocity window a configurable fault reaction will be activated.

Once the activation request is received, SSR will become active depending on what occurs first:

- The time to velocity monitoring is elapsed (t_SSR)
- The current velocity stays in the configured velocity window for a given amount of time (t_L_SSR)

Optionally, the deceleration ramp can be monitored after some delay (t_D_SSR) to check whether the current velocity is below the computed velocity ramp (a_SSR). If the velocity is above the computed velocity ramp, the fault reaction will be activated.

Number of Instances

Three instances per axis.

Function Input / Output Variables

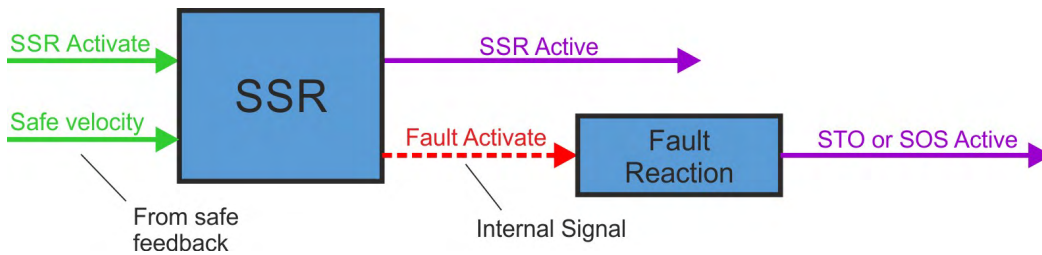

Inputs

- **SSR Active** can be triggered by FSoE or safe digital inputs (must be mapped)
- **Safe velocity**: velocity signal from safe feedback

Outputs

- **SSR Active**: logical status of the SSR function
- **Fault Activate**: activate fault reaction

9.4.13.2 Activation

Activation by FSoE	<ul style="list-style-type: none"> • For a drive profile overview, see FSoE (FSoE, → # 213). • For setup and handling, see the <i>AKD2G EtherCAT Manual</i>.
Activation by safe digital inputs	<ul style="list-style-type: none"> • To review the enclosure and wiring instructions, see Enclosure, wiring (Enclosure, wiring, → # 198). • To see technical data for the safe inputs, see Technical Data (Technical Data, → # 210). • For notes on activation by safe inputs, see Activation by Safety Digital Inputs (Activation By Safe Digital Inputs, → # 205).

9.4.13.3 Timing

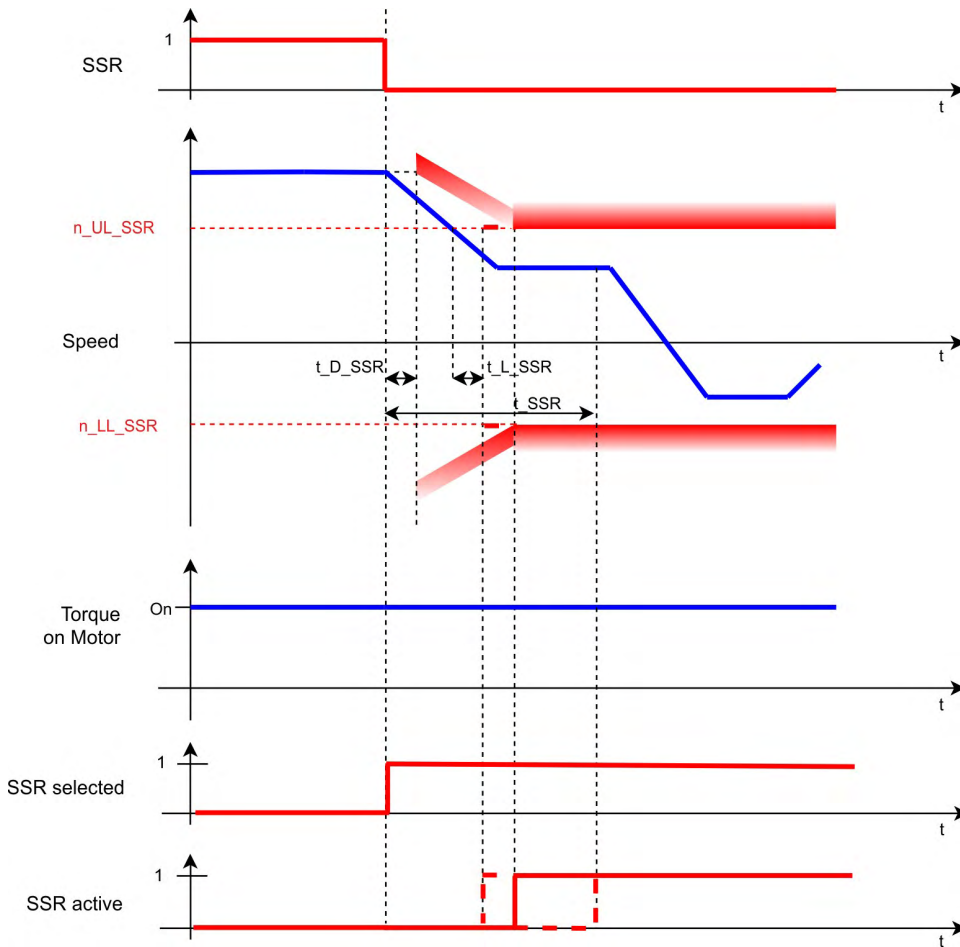

9.4.13.4 Related Parameters

Safety parameters

Name	Variables	Default	Parameter
Function Activation	-	0 (Never active)	(→ # 483)
Safe Input	-	0 (Not used)	(→ # 484)
FSoE	-	0 (Not used)	(→ # 482)
Time To Velocity Monitoring	t_SSR	2 ms	(→ # 487)
Velocity Upper Limit	n_UL_SSR	0 (Vel user units)	(→ # 489)
Velocity Lower Limit	n_LL_SSR	0 (Vel user units)	(→ # 488)
Time For Velocity in Limits	t_L_SSR	1 ms	(→ # 486)
Deceleration Monitoring	-	0 (Disabled)	(→ # 480)
Deceleration Limit	a_SSR	0 (Dec user units)	(→ # 479)
Time Delay Deceleration Monitoring	t_D_SSR	1 ms	(→ # 485)
Fault Reaction	-	1 (STO)	(→ # 481)

Diagnostic parameters

Name	Variables	Default	Parameter
Function Active Status	-	-	(→ # 380)
Function Internal Status	-	-	(→ # 381)

9.4.13.5 Setup in WorkBench

Select the drive and open the Safety Parameterization view (→ # 293).

Choose the axis (1), category (2), SSR function (3) and the instance number (4).



Parameters Editor

[Learn more about this topic](#)

Configuration of the safety parameters.

Axes	Categories	Safe Speed	Instances
Common	General	SLS (Safe Limited Speed)	Instance 1
Axis 1	Safe Stop	SSM (Safe Speed Monitor)	Instance 2
Axis 2	Safe Speed	SSR (Safe Speed Range)	Instance 3
	Safe Position	SDI (Safe Direction)	
		SLA (Safe Limited Acceleration)	
		SAR (Safe Acceleration Range)	

[Goto Safety Parameter Download](#)

[SafeID: 1] Axis 1 > Safe Speed > SSR (Safe Speed Range) > Instance 1



User Units (for information only)

Position: N/A Velocity: N/A Acceleration: N/A

Parameter	Value	Unit
Axis 1 - Safe Speed - SSR - Instance 1		
Function Activation	Ready for Activation	
Safe Input	Not Used	
FSoE	Not Used	
Time to Velocity Monitoring (t_SSR)	2	ms
Velocity Upper Limit (n_UL_SSR)	0	Velocity User Units
Velocity Lower Limit (n_LL_SSR)	0	Velocity User Units
Time for Velocity in Limits (t_L_SSR)	1	ms
Deceleration Monitoring	Enabled	
Deceleration Limit (a_SSR)	0	Acceleration User Units
Time Delay Deceleration Monitoring (t_D_SSR)	1	ms
Fault Reaction	STO	

9.4.13.6 Fault Reaction / Failure Messages

SSR has a configurable fault reaction. STO is used by default but can be replaced by SS1 Instance 1 or SS2 Instance 1. When the fault reaction is activated, SSR remains active and the internal state (AXIS#.SAFE.SSR_#.INTERNALSTATE) is set to failed state (5).

9.4.13.7 Safety State / Status Signals

The signal AXIS#.SAFE.SSR_#.ACTIVE can be monitored by safe digital outputs with OSSD pulses (→ # 212). The status signal must be mapped to the safe digital output. Two outputs can be combined to a dual channel output. For parameter description refer to (→ # 315).

9.4.13.8 Safety Properties

Refer to (Safety Properties Overview, → # 203).

9.4.14 SDI (Safe Direction)

SDIn/SDIp description for drive option Functional Safety 3.

9.4.14.1 Description

SDI monitors the direction of movement and activates a configurable fault reaction when a violation occurs. SDI consists of two sub-functions: SDIp (for positive direction) and SDIn (for negative direction). Both functions share

- the same position window parameter `s_Zero_SDI`,
- the same velocity limit parameter `n_Zero_SDI` and
- the same configurable fault reaction.

However, they have their own sources of activation and their own delay before monitoring (`t_D_SDIp` and `t_D_SDIin`):

- When SDIp is activated, the safety module prevents motion in the positive direction. The motion can either be in the negative direction or be stopped.
- When SDIn is activated, the safety module prevents motion in the negative direction. The motion can either be in the positive direction or be stopped.
- If both functions are activated at the same time, the motion must be stopped.

Number of Instances

One instance per axis.

Function Input / Output Variables

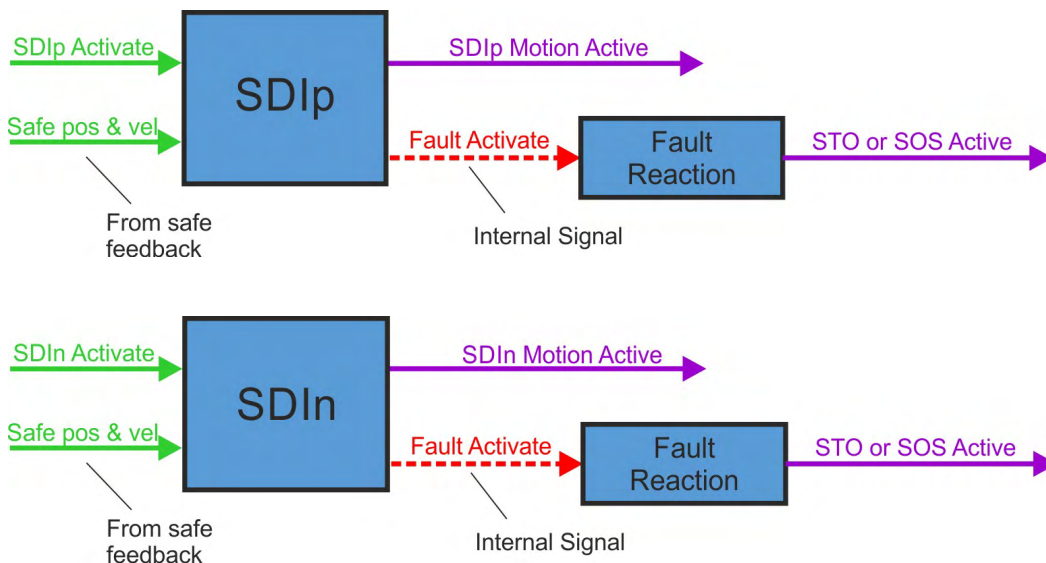

Inputs

- **SDIp Activate** can be triggered by FSoE or safe digital inputs (must be mapped)
- **SDIn Activate** can be triggered by FSoE or safe digital inputs (must be mapped)
- **Safe pos & vel:** position and velocity signal from safe feedback

Outputs

- **SDIp Motion Active:** indicates whether the axis is moving in the positive direction
- **SDIn Motion Active:** indicates whether the axis is moving in the negative direction
- **Fault Activate:** activate fault reaction

9.4.14.2 Activation

<p>Activation by FSoE</p>	<ul style="list-style-type: none"> • For a drive profile overview, see FSoE (FSoE, → # 213). • For setup and handling, see the <i>AKD2G EtherCAT Manual</i>.
<p>Activation by safe digital inputs</p>	<ul style="list-style-type: none"> • To review the enclosure and wiring instructions, see Enclosure, wiring (Enclosure, wiring, → # 198). • To see technical data for the safe inputs, see Technical Data (Technical Data, → # 210). • For notes on activation by safe inputs, see Activation by Safety Digital Inputs (Activation By Safe Digital Inputs, → # 205).

9.4.14.3 Timing

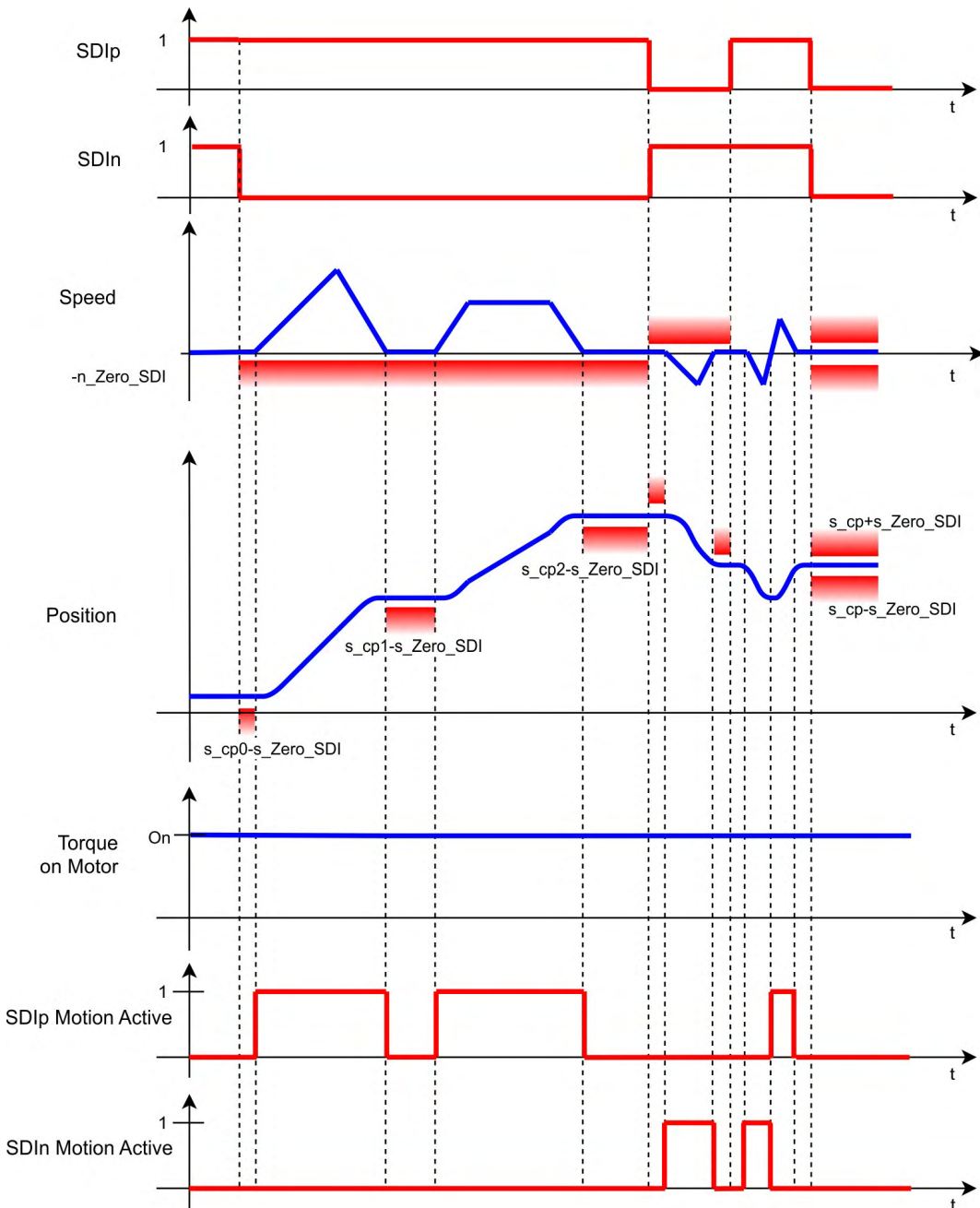

s_{cp} defines the safe position which is taken while the function activates. It is used to compute the range of allowed position values that the axis can take while the position monitoring is activated. The range is computed by adding or subtracting s_Zero_SDI to/from the parameter s_{cp} .

9.4.14.4 Related Parameters

Safety parameters

Name	Variables	Default	Parameter
Function Activation	-	0 (Never active)	(→ # 414)
Safe Input SDIp	-	0 (Not used)	(→ # 421)
FSoE SDIp	-	0 (Not used)	(→ # 420)
Safe Input SDIn	-	0 (Not used)	(→ # 418)
FSoE SDIn	-	0 (Not used)	(→ # 417)
Position Zero Window	s_Zero_SDI	1 (Pos user units)	(→ # 415); usable value range depends on used encoder type, see (Limitations, → # 553)
Velocity Zero Window	n_Zero_SDI	1 (Vel user units)	(→ # 416)
Time Delay Monitoring SDIp	t_D_SDIp	1 ms	(→ # 422)
Time Delay Monitoring SDIn	t_D_SDIIn	1 ms	(→ # 419)
Fault Reaction	-	1 (STO)	(→ # 413)

Diagnostic parameters

Name	Variables	Default	Parameter
SDIp Moving	-	-	(→ # 360)
SDIp Function Internal Status	-	-	(→ # 359)
SDIn Moving	-	-	(→ # 358)
SDIn Function Internal Status	-	-	(→ # 357)

9.4.14.5 Setup in WorkBench

Select the drive and open the Safety Parameterization view (→ # 293).

Choose the axis (1), category (2), SDI function (3) and the instance number (4).



Parameters Editor

Configuration of the safety parameters.

[Learn more about this topic](#)

The screenshot shows the Parameters Editor interface with four red circles highlighting the navigation path: 1. Axis selection (Axis 1), 2. Category selection (Safe Speed), 3. SDI function selection (SDI (Safe Direction)), and 4. Instance selection (Instance 1).

[Goto Safety Parameter Download](#)

[SafeID: 1] Axis 1 > Safe Speed > SDI (Safe Direction) > Instance 1



User Units (for information only)

Position: N/A

Velocity: N/A

Acceleration: N/A

Parameter	Value	Unit
Axis 1 - Safe Speed - SDI - Instance 1		
Function Activation	Ready for Activation	
Safe Input SDIp	Safe input 1 (SIN1)	
FSoE SDIp	Not Used	
Safe Input SDIn	Safe input 2 (SIN2)	
FSoE SDIn	Not Used	
Position Zero Window (s_Zero_SDI)	1	Position User Units
Velocity Zero Window (n_Zero_SDI)	1	Velocity User Units
Time Delay Monitoring SDIp (t_D_SDIp)	1	ms
Time Delay Monitoring SDIn (t_D_SDIIn)	1	ms
Fault Reaction	STO	

9.4.14.6 Fault Reaction / Failure Messages

SDI has a configurable fault reaction. STO is used by default but can be replaced by SS1 Instance 1 or SS2 Instance 1. When the fault reaction is activated, the internal states of SDI ([AXIS#.SAFE.SDIp.INTERNALSTATE](#) and [AXIS#.SAFE.SDIIn.INTERNALSTATE](#)) are set to failed state (4).

9.4.14.7 Safety State / Status Signals

The signals [AXIS#.SAFE.SDIIn.MOTIONACTIVE](#) and [AXIS#.SAFE.SDIp.MOTIONACTIVE](#) can be monitored by safe digital outputs with OSSD pulses (→ # 212). The status signals must be mapped to the safe digital outputs. Two outputs can be combined to a dual channel output. For parameter description refer to (→ # 315).

9.4.14.8 Safety Properties

Refer to (Safety Properties Overview, → # 203).

9.4.15 SLA (Safely Limited Acceleration)

SLA description for drive option Functional Safety 3.

9.4.15.1 Description

SLA, when active, monitors the acceleration and ensures that it stays in an acceleration window. The acceleration window is described by the unsigned parameter `a_SL` where `-a_SL` defines the lower limit and `+a_SL` defines the upper limit. If the acceleration leaves the acceleration window, a configurable fault reaction will be activated.

Number of Instances

One instance per axis.

Function Input / Output Variables

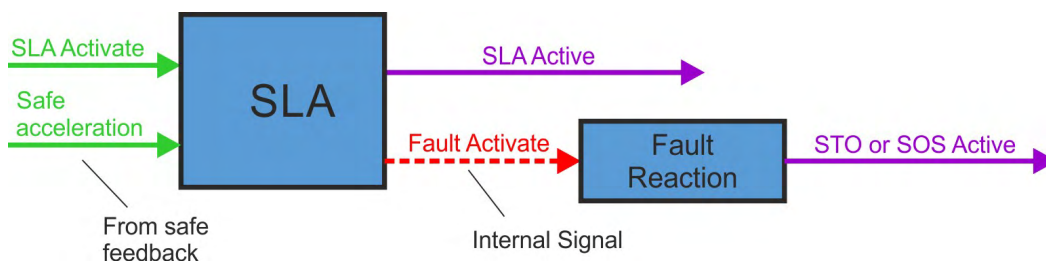

Inputs

- **SLA Activate** can be triggered by FSoE or safe digital inputs (must be mapped)
- **Safe acceleration**: signal from safe feedback

Outputs

- **SLA Active**: logical status of the SLA function
- **Fault Activate**: activate fault reaction

9.4.15.2 Activation

Activation by FSoE	<ul style="list-style-type: none"> • For a drive profile overview, see FSoE (FSoE, → # 213). • For setup and handling, see the <i>AKD2G EtherCAT Manual</i>.
Activation by safe digital inputs	<ul style="list-style-type: none"> • To review the enclosure and wiring instructions, see Enclosure, wiring (Enclosure, wiring, → # 198). • To see technical data for the safe inputs, see Technical Data (Technical Data, → # 210). • For notes on activation by safe inputs, see Activation by Safety Digital Inputs (Activation By Safe Digital Inputs, → # 205).

9.4.15.3 Timing

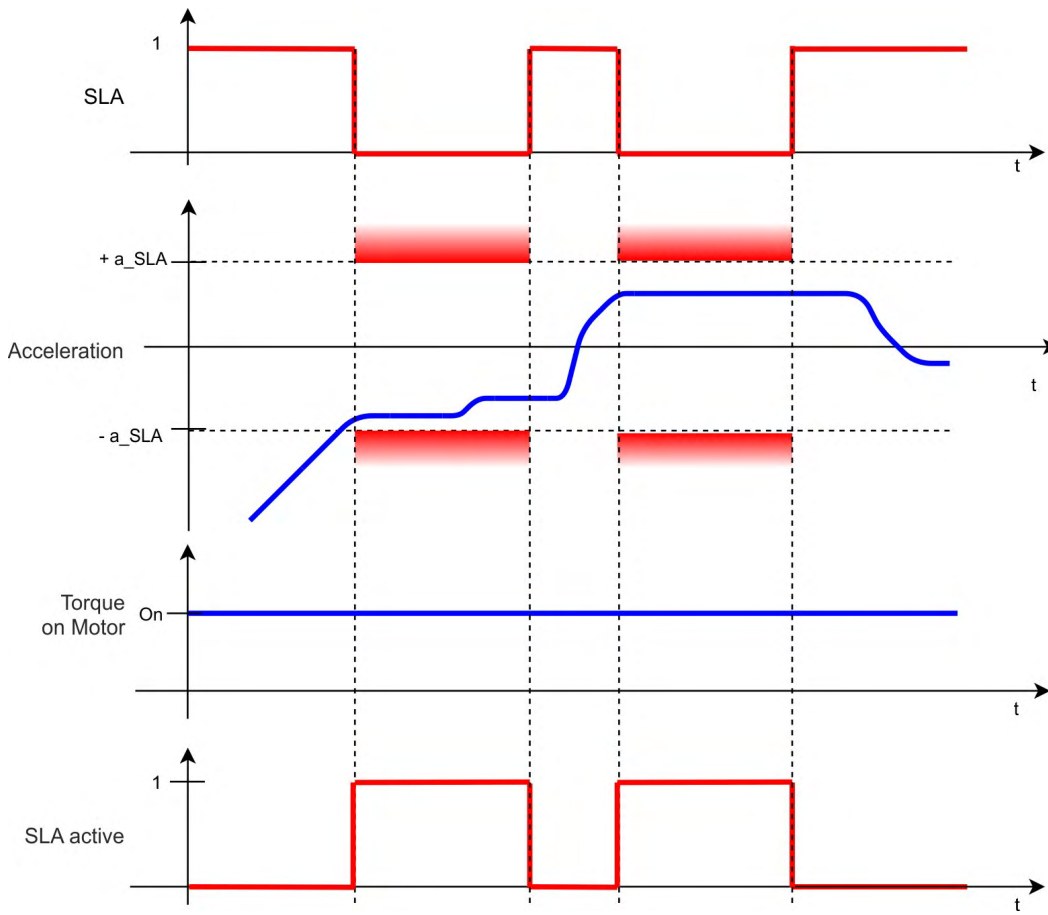

9.4.15.4 Related Parameters

Safety parameters

Name	Variables	Default	Parameter
Function Activation	-	0 (Never active)	(→ # 426)
Safe Input	-	0 (Not used)	(→ # 427)
FSoE	-	0 (Not used)	(→ # 425)
Acceleration Limit	a_SL A	1 (Acc user units)	(→ # 423)
Fault Reaction	-	1 (STO)	(→ # 424)

Diagnostic parameters

Name	Variables	Default	Parameter
Function Active Status	-	-	(→ # 361)
Function Internal Status	-	-	(→ # 362)

9.4.15.5 Setup in WorkBench

Select the drive and open the Safety Parameterization view (→ # 293).

Choose the axis (1), category (2) and the SLA function (3).



Parameters Editor

Configuration of the safety parameters.

[Learn more about this topic](#)

Axes	Categories	Safe Speed	Instances
Common	General	SLS (Safe Limited Speed)	Instance 1
Axis 1	Safe Stop	SSM (Safe Speed Monitor)	
Axis 2	Safe Speed	SSR (Safe Speed Range)	
	Safe Position	SDI (Safe Direction)	
		SLA (Safe Limited Acceleration)	
		SAR (Safe Acceleration Range)	

[Goto Safety Parameter Download](#)

[SafeID: 1] Axis 1 > Safe Speed > SLA (Safe Limited Acceleration) > Instance 1



User Units (for information only)

Position: N/A

Velocity: N/A

Acceleration: N/A

Type:	Kollmorgen AKD2G SMM		
Description:	Kollmorgen AKD2G SafeMotion Monitor		
Import file:	-		
Parameter	Value	Unit	
Axis 1 - Safe Speed - SLA - Instance 1			
Function Activation	Ready for Activation		
Safe Input	Safe input 1 (SIN1)		
FSoE	Not Used		
Acceleration Limit (a_SLAs)	1	Acceleration User Units	
Fault Reaction	STO		

9.4.15.6 Fault Reaction / Failure Messages

SLA has a configurable fault reaction. STO is used by default but can be replaced by SS1 Instance 1 or SS2 Instance 1. When the fault reaction is activated, SLA remains active and the internal state ([AXIS#.SAFE.SLA.INTERNALSTATE](#)) is set to failed state (2).

9.4.15.7 Safety State / Status Signals

The signal [AXIS#.SAFE.SLA.ACTIVE](#) can be monitored by safe digital outputs with OSSD pulses (→ # 212). The status signal must be mapped to the safe digital output. Two outputs can be combined to a dual channel output. For parameter description refer to (→ # 315).

9.4.15.8 Safety Properties

Refer to (→ # 203).

9.4.16 SAR (Safe Acceleration Range)

SAR description for drive option Functional Safety 3.

9.4.16.1 Description

SAR, when active, monitors the acceleration and ensures that it stays in an acceleration window. The acceleration window is defined by two parameters: a_UL_SAR (acceleration upper limit) and a_LL_SAR (acceleration lower limit). If the acceleration leaves the acceleration window a configurable fault reaction will be activated.

Number of instances

Three instances per axis.

Function Input/Output variables

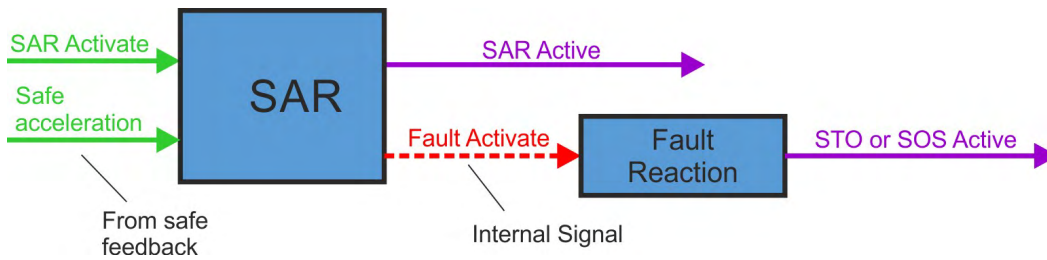

Inputs

- **SAR Activate** can be triggered by FSoE or safe digital inputs (must be mapped)
- **Safe acceleration**: acceleration signal from safe feedback

Outputs

- **SAR Active**: logical status of the SAR function
- **Fault Activate**: activate fault reaction

9.4.16.2 Activation

Activation by FSoE	<ul style="list-style-type: none"> • For a drive profile overview, see FSoE (FSoE, → # 213). • For setup and handling, see the <i>AKD2G EtherCAT Manual</i>.
Activation by safe digital inputs	<ul style="list-style-type: none"> • To review the enclosure and wiring instructions, see Enclosure, wiring (Enclosure, wiring, → # 198). • To see technical data for the safe inputs, see Technical Data (Technical Data, → # 210). • For notes on activation by safe inputs, see Activation by Safety Digital Inputs (Activation By Safe Digital Inputs, → # 205).

9.4.16.3 Timing

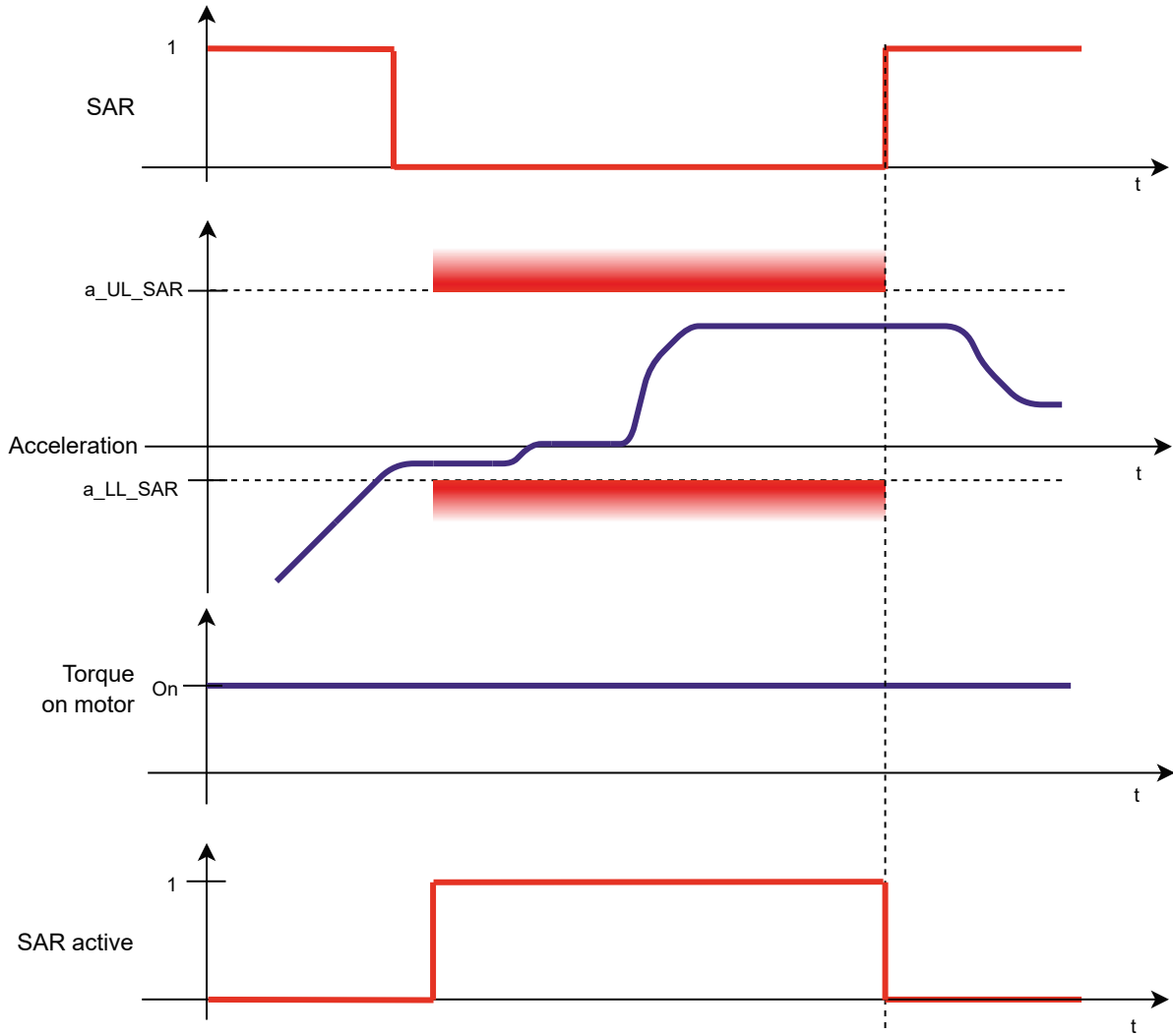

9.4.16.4 Related Parameters

Safety parameters

Name	Variables	Default	Parameter
Function Activation	-	0 (Never active)	(→ # 397)
Safe Input	-	0 (Not used)	(→ # 398)
FSoE	-	0 (Not used)	(→ # 396)
Acceleration Upper Limit	a_UL_SAR	1 (Acc user units)	(→ # 394)
Acceleration Lower Limit	a_LL_SAR	1 (Acc user units)	(→ # 393)
Fault Reaction	-	1 (STO)	(→ # 395)

Diagnostic parameters

Name	Variables	Default	Parameter
Function Active Status	-	-	(→ # 348)
Function Internal Status	-	-	(→ # 349)

9.4.16.5 Setup in WorkBench

Select the drive and open the Safety Parameterization view (→ # 293).

Choose the axis (1), category (2), SAR function (3) and the instance number (4).



Parameters Editor

[Learn more about this topic](#)

Configuration of the safety parameters.

The screenshot shows the Parameters Editor interface with four red circles highlighting navigation steps: 1. 'Axis 1' in the 'Axes' list; 2. 'Safe Speed' in the 'Categories' list; 3. 'SAR (Safe Acceleration Range)' in the 'Safe Speed' list; 4. 'Instance 1' in the 'Instances' list.

[SafeID: 1] Axis 1 > Safe Speed > SAR (Safe Acceleration Range) > Instance 1

The screenshot shows the configuration page for SAR (Safe Acceleration Range) Instance 1. It includes a header with 'User Units (for information only)' and 'Position: N/A', 'Velocity: N/A', 'Acceleration: N/A'. Below is a table with the following data:

Parameter	Value	Unit
Axis 1 - Safe Speed - SAR - Instance 1		
Function Activation	Ready for Activation	
Safe Input	Not Used	
FSoE	Not Used	
Acceleration Upper Limit (a_UL_SAR)	1	Acceleration User Units
Acceleration Lower Limit (a_LL_SAR)	1	Acceleration User Units
Fault Reaction	STO	

9.4.16.6 Fault Reaction / Failure Messages

SAR has a configurable fault reaction. STO is used by default but can be replaced by SS1 Instance 1 or SS2 Instance 1. When the fault reaction is activated, SAR remains active and the internal state (AXIS#.SAFE.SAR_#.INTERNALSTATE) is set to failed state (2).

9.4.16.7 Safety State / Status signals

The signal AXIS#.SAFE.SAR_#.ACTIVE can be monitored by safe digital outputs with OSSD pulses (→ # 212). The status signal must be mapped to the safe digital output. Two outputs can be combined to a dual channel output. For parameter description refer to (→ # 315).

9.4.16.8 Safety Properties

Refer to (Safety Properties Overview, → # 203).

9.4.17 SLI (Safely Limited Increment)

SLI description for drive option Functional Safety 3.

9.4.17.1 Description

SLI, when active, monitors the incremental position and ensures that it stays in a position window. This position window is defined as follows:

The position is taken at the time where the function gets activated. For the upper limit the parameter `s_UL_SLI` is added. For the lower limit the parameter `s_LL_SLI` is subtracted. If the position leaves the position window a configurable fault reaction will be activated.

If necessary, the start of monitoring can be delayed by using the configurable parameter `t_D_SLI`.

Number of Instances

Three instances per axis.

Function Input / Output Variables

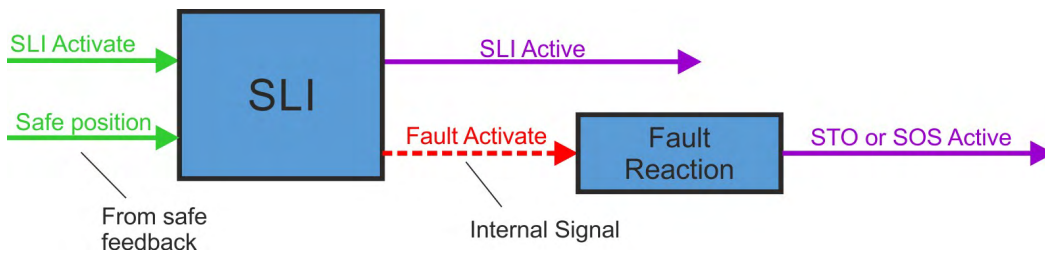

Inputs

- **SLI Activate** can be triggered by FSoE or safe digital inputs (must be mapped)
- **Safe position**: position signal from safe feedback

Outputs

- **SLI Active**: logical status of the SLI function
- **Fault Activate**: activate fault reaction

9.4.17.2 Activation

Activation by FSoE	<ul style="list-style-type: none"> • For a drive profile overview, see FSoE (FSoE, → # 213). • For setup and handling, see the <i>AKD2G EtherCAT Manual</i>.
Activation by safe digital inputs	<ul style="list-style-type: none"> • To review the enclosure and wiring instructions, see Enclosure, wiring (Enclosure, wiring, → # 198). • To see technical data for the safe inputs, see Technical Data (Technical Data, → # 210). • For notes on activation by safe inputs, see Activation by Safety Digital Inputs (Activation By Safe Digital Inputs, → # 205).

9.4.17.3 Timing

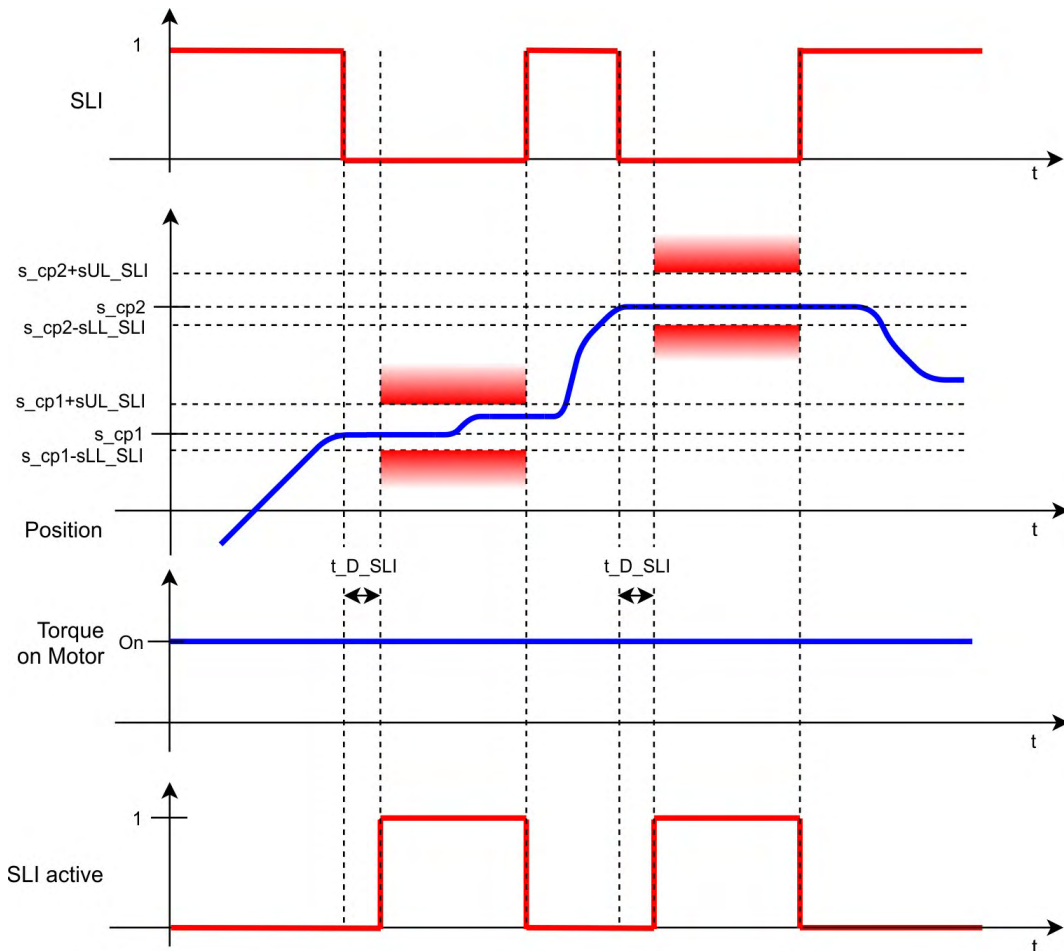

s_{cp} defines the safe position which is taken while the function gets activated. It is used to compute the range of allowed position values that the axis can take while the position monitoring is activated. The range is computed by adding or subtracting s_{UL_SLI}/s_{LL_SLI} to/from the parameter s_{cp} .

9.4.17.4 Related Parameters

Safety parameters

Name	Variables	Default	Parameter
Function Activation	-	0 (Never active)	(→ # 430)
Safe Input	-	0 (Not used)	(→ # 433)
FSoE	-	0 (Not used)	(→ # 429)
Position Relative Upper Limit	s_{UL_SLI}	1 (Pos user units)	(→ # 432); usable value range depends on used encoder type, see (Limitations, → # 553)
Position Relative Lower Limit	s_{LL_SLI}	1 (Pos user units)	(→ # 431); usable value range depends on used encoder type, see (Limitations, → # 553)
Time Delay Monitoring	t_{D_SLI}	0 ms	(→ # 434)
Fault Reaction	-	1 (STO)	(→ # 428)

Diagnostic parameters

Name	Variables	Default	Parameter
Function Active Status	-	-	(→ # 363)
Function Internal Status	-	-	(→ # 364)

9.4.17.5 Setup in WorkBench

Select the drive and open the Safety Parameterization view (→ # 293).

Choose axis (1), category (2), SLI function (3) and the instance number (4).

Parameters Editor [Learn more about this topic](#)

Configuration of the safety parameters.

Axes	Categories	Safe Position	Instances
Common	General	SLI (Safe Limited Increment)	Instance 1
Axis 1	Safe Stop	SLP (Safe Limited Position)	Instance 2
Axis 2	Safe Speed	SCA (Safe CAm)	Instance 3
	Safe Position		

[Goto Safety Parameter Download](#)

[SafeID: 1] Axis 1 > Safe Position > SLI (Safe Limited Increment) > Instance 1

User Units (for information only)
 Position: N/A Velocity: N/A Acceleration: N/A

Type: **Kollmorgen AKD2G SMM**
 Description: **Kollmorgen AKD2G SafeMotion Monitor**
 Import file: -

Parameter	Value	Unit
Axis 1 - Safe Position - SLI - Instance 1		
Function Activation	Ready for Activation	
Safe Input	Not Used	
FSoE	Not Used	
Position Relative Upper Limit (s_UL_SLI)	1	Position User Units
Position Relative Lower Limit (s_LL_SLI)	1	Position User Units
Time Delay Monitoring (t_D_SLI)	0	ms
Fault Reaction	STO	

9.4.17.6 Fault Reaction / Failure Messages

SLI has a configurable fault reaction. STO is used by default but can be replaced by SS1 Instance 1 or SS2 Instance 1. When the fault reaction is activated, SLI remains active and the internal state (AXIS#.SAFE.SLI_#.INTERNALSTATE) is set to failed state (3).

9.4.17.7 Safety State / Status Signals

The signal AXIS#.SAFE.SLI_#.ACTIVE can be monitored by safe digital outputs with OSSD pulses (→ # 212). The status signal must be mapped to the safe digital output. Two outputs can be combined to a dual channel output. For parameter description refer to (→ # 315).

9.4.17.8 Safety Properties

Refer to (Safety Properties Overview, → # 203).

9.4.18 SLP (Safely Limited Position)

SLP description for drive option Functional Safety 3.

9.4.18.1 Description

When active, SLP monitors the position and ensures that it stays in a position window. The upper limit of the position window is defined by the parameter `s_UL_SLP` and the lower limit is defined by the parameter `s_LL_SLP`. If the position leaves this position window while the function is active, a configurable fault reaction will be activated.

If necessary, the start of monitoring can be delayed by using the configurable parameter `t_D_SLP`.

Number of instances

Three instances per axis.

Function Input / Output Variables

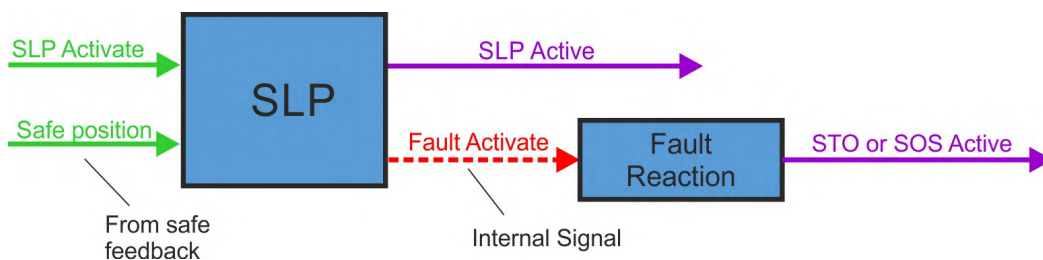

Inputs

- **SLP Activate** can be triggered by FSoE or safe digital inputs (must be mapped)
- **Safe Position**: position signal from safe feedback

Outputs

- **SLP Active**: logical status of the SLP function
- **Fault Activate**: activate fault reaction

9.4.18.2 Activation

Activation by FSoE	<ul style="list-style-type: none"> • For a drive profile overview, see FSoE (FSoE, → # 213). • For setup and handling, see the <i>AKD2G EtherCAT Manual</i>.
Activation by safe digital inputs	<ul style="list-style-type: none"> • To review the enclosure and wiring instructions, see Enclosure, wiring (Enclosure, wiring, → # 198). • To see technical data for the safe inputs, see Technical Data (Technical Data, → # 210). • For notes on activation by safe inputs, see Activation by Safety Digital Inputs (Activation By Safe Digital Inputs, → # 205).

9.4.18.3 Timing

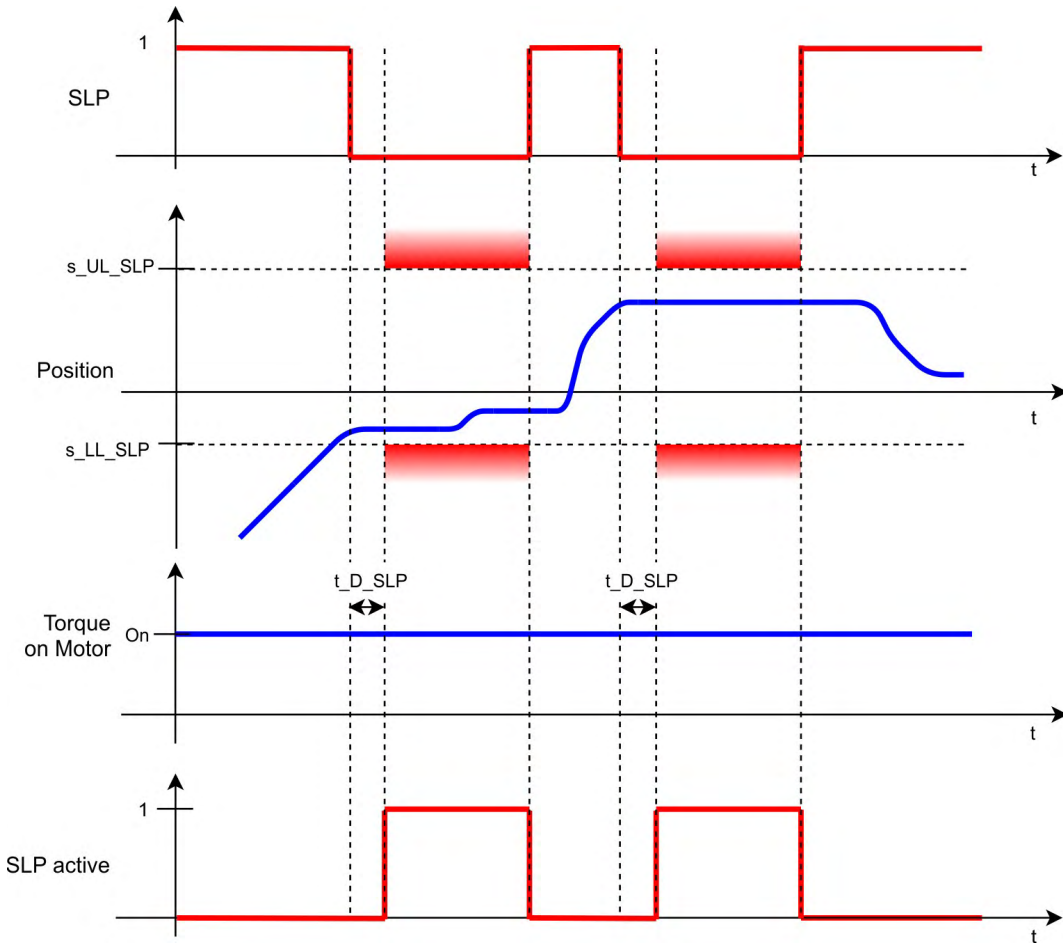

9.4.18.4 Related Parameters

Safety parameters

Name	Variables	Default	Parameter
Function Activation	-	0 (Never active)	(→ # 437)
Safe Input	-	0 (Not used)	(→ # 440)
FSoE	-	0 (Not used)	(→ # 436)
Position Upper Limit	s_UL_SLP	1 (Pos user units)	(→ # 439)
Position Lower Limit	s_LL_SLP	1 (Pos user units)	(→ # 438)
Time Delay Monitoring	t_D_SLP	0 ms	(→ # 441)
Fault Reaction	-	1 (STO)	(→ # 435)

Diagnostic parameters

Name	Variables	Default	Parameter
Function Active Status	-	-	(→ # 365)
Function Internal Status	-	-	(→ # 366)

9.4.18.5 Setup in WorkBench

Select the drive and open the Safety Parameterization view "Parameters Editor" (→ # 293).
 Choose axis (1), category (2), SLP function (3) and the instance number (4).

 **Parameters Editor** [Learn more about this topic](#)

Configuration of the safety parameters.

Axes	Categories	Safe Position	Instances
Common	General	SLI (Safe Limited Increment)	Instance 1
Axis 1	Safe Stop	SLP (Safe Limited Position)	Instance 2
Axis 2	Safe Speed	SCA (Safe CAm)	Instance 3
	Safe Position		

[Goto Safety Parameter Download](#)

[SafeID: 1] Axis 1 > Safe Position > SLP (Safe Limited Position) > Instance 1 

User Units (for information only)

Position: N/A Velocity: N/A Acceleration: N/A

Type: **Kollmorgen AKD2G SMM**
 Description: **Kollmorgen AKD2G SafeMotion Monitor**
 Import file: -

Parameter	Value	Unit
Axis 1 - Safe Position - SLP - Instance 1		
Function Activation	Ready for Activation	
Safe Input	Not Used	
FSoE	Not Used	
Position Upper Limit (s_UL_SLP)	1	Position User Units
Position Lower Limit (s_LL_SLP)	1	Position User Units
Time Delay Monitoring (t_D_SLP)	0	ms
Fault Reaction	STO	

9.4.18.6 Fault Reaction / Failure Messages

SLP has a configurable fault reaction. STO is used by default but can be replaced by SS1 Instance 1 or SS2 Instance 1. When the fault reaction is activated, SLP remains active and the internal state ("AXIS#.SAFE.SLP_#.INTERNALSTATE" (→ # 366)) is set to failed state (2).

9.4.18.7 Safety State / Status Signals

The signal (→ # 365) can be monitored by safe digital outputs with "OSSD" (→ # 212) pulses. The status signal must be mapped to the safe digital output. Two outputs can be combined to a dual channel output. For parameter description refer to "Functional Safety Parameter Reference" (→ # 315).

9.4.18.8 Safety Properties

Refer to "Safety Properties Overview" (→ # 203).

9.4.19 SCA (Safe Cam)

SCA description for drive option Functional Safety 3.

9.4.19.1 Description

SCA is a pure monitoring function which has no fault reaction. Once configured, it stays activated monitoring whether the position stays within a position window. The parameter `n_UL_SCA` defines the upper limit and the parameter `n_LL_SCA` defines the lower limit of this window.

The SCA function returns a logical status, called `InRange`, which tells whether the position is currently located in the position window or not.

Number of Instances

Three instances per axis.

Function Input / Output Variables

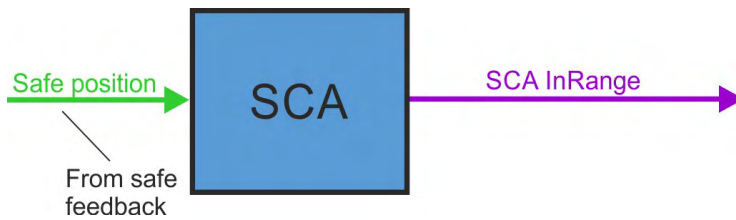

Input

- **Safe position:** position signal from safe feedback

Outputs

- **SCA InRange:** logical status telling if the position is in the range defined by the SCA function

9.4.19.2 Activation

No activation source. Once configured in the safety parameters, it stays activated.

9.4.19.3 Related Parameters

Safety parameters

Name	Variables	Default	Parameter
Function Activation	-	0 (Never active)	(→ # 407)
Position Upper Limit	<code>s_UL_SCA</code>	0 (Pos user units)	(→ # 409)
Position Lower Limit	<code>s_LL_SCA</code>	0 (Pos user units)	(→ # 408)

Diagnostic parameters

Name	Variables	Default	Parameter
SCA In Range	-	-	(→ # 355)
Function Internal Status	-	-	(→ # 356)

9.4.19.4 Timing

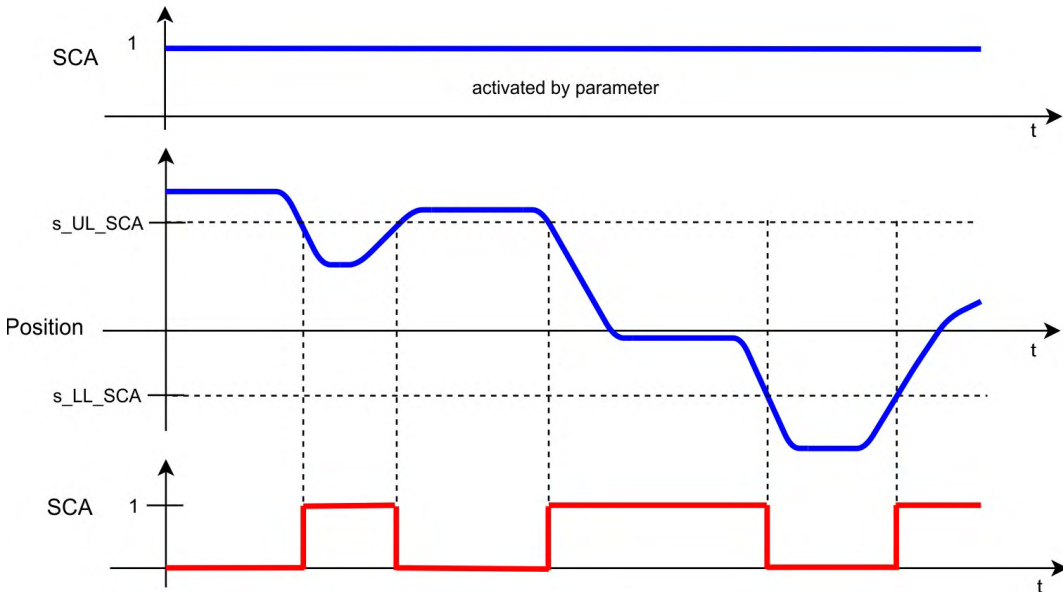

9.4.19.5 Setup in WorkBench

Select the drive and open the Safety Parameterization view (→ # 293).

Choose the axis (1), category (2), SCA function (3) and the instance number (4).



Parameters Editor

Configuration of the safety parameters.

[Learn more about this topic](#)

Axes	Categories	Safe Position	Instances
Common Axis 1 Axis 2	General Safe Stop Safe Speed Safe Position	SLI (Safe Limited Increment) SLP (Safe Limited Position) SCA (Safe CAm)	Instance 1 Instance 2 Instance 3
1	2	3	4

[Goto Safety Parameter Download](#)

[SafeID: 1] Axis 1 > Safe Position > SCA (Safe CAm) > Instance 1



User Units (for information only)

Position: N/A Velocity: N/A Acceleration: N/A

Type:	Kollmorgen AKD2G SMM		
Description:	Kollmorgen AKD2G SafeMotion Monitor		
Import file:			
Parameter	Value	Unit	
Axis 1 - Safe Position - SCA - Instance 1			
Function Activation	Always Active		
Position Upper Limit (s_UL_SCA)	0	Position User Units	
Position Lower Limit (s_LL_SCA)	0	Position User Units	

9.4.19.6 Safety State / Status Signals

The signal `AXIS#.SAFE.SCA_#.INRANGE` can be monitored by safe digital outputs with OSSD pulses (→ # 212).

The status signal must be mapped to the safe digital output. Two outputs can be combined to a dual channel output.

For parameter description refer to (→ # 315).

9.4.19.7 Safety Properties

Refer to (Safety Properties Overview, → # 203).

9.5 Settings

9.5.1 Display, Push-Buttons and Rotary Switches

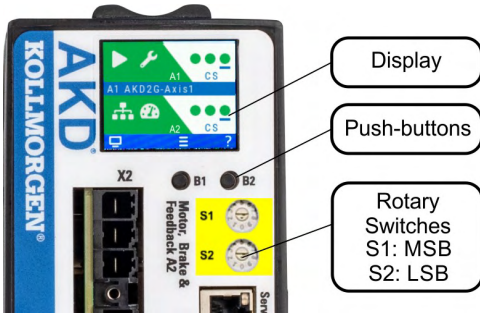

Display (example for a dual-axis module)

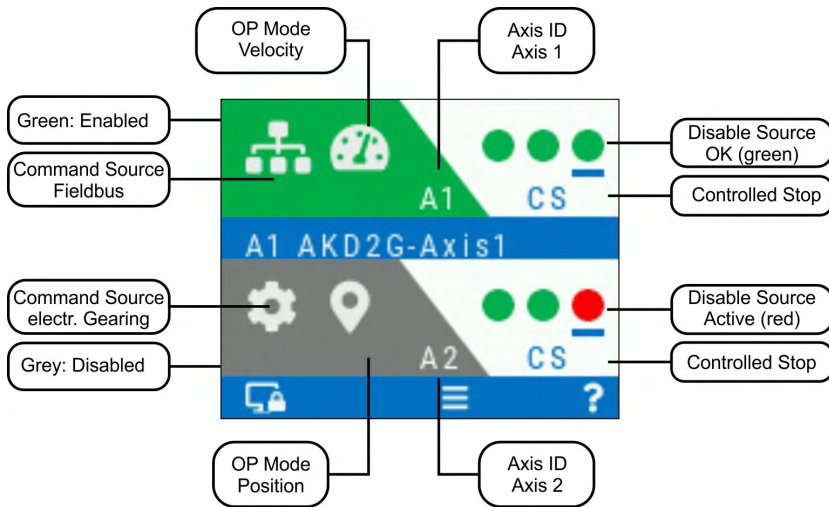

Push buttons (B1, B2)

A short button press invokes the action corresponding to the symbol directly above the button. On the dashboard for example,

- a short press on B1 causes the menu system to appear, and
- a short press on B2 causes a help screen to appear.
- A long press (greater than 2 seconds) on B2 returns the display to the previous screen.

B1 / B2 Functions	Description
Boot from SD card	Push both buttons during power up to boot with data from the SD card. Press the buttons first, then hold it down while turning on the 24V power supply.
Boot from flash fallback image	Remove the SD card, then press both buttons and hold them down while turning on the 24V power supply to boot from an on-board recovery image.
SafeID Validation	Push B2 to acknowledge SafeID validation request on the display.

Rotary switches (S1, S2)

Two decimal coded rotary switches are used to set a unique SafeID for the drive. S1 sets the tens place, S2 sets the ones place.

Process:

1. Switch off 24V supply voltage.
2. Set S1 and S2 to a unique SafeID.
3. Switch on the 24V supply voltage.

9.5.2 Default Safety Parameters

Default device parameters

The AKD2Gships with pre-configured default safety parameters. The SafeID will be set to 1 and a set of parameters will be downloaded in the non-volatile memory of the SMM. The drive is ready to operate with pre-configured STO function. When these parameters are cleared or when the SafeID is changed, this parameter set is lost and cannot be retrieved.

WorkBench: default safety parameters

These are the parameters pre-configured on the safety device when added as a new safety device to a safety project. The SafeID is set to 1 by default. You can change these parameters. The default values correspond to the pre-programmed default device parameters.

FSoE parametrization: default parameters

Safety parameters can be downloaded through EtherCAT SDO (→ # 298) and then validated through FSoE using the SRA CRC ([AXISx.SAFE.FSOE.SRACRC](#)). By default, parameters will be downloaded with their default values found in the ESI file.

To use FSoE parametrization, clear the parameters from the non-volatile memory. The FSoE parameters are stored in the volatile memory only and they will be invalidated after a reboot or a restart of the FSoE stack.

9.5.3 SafeID

NOTICE

If you configure a functional safety system, you have the responsibility to ensure that:

- every AKD2G has a distinct SafeID,
- every device on the safe fieldbus has a unique FSoE address,
- the SafeID is adjusted to the application during commissioning (→ # 201),
- the SafeID is validated to the application (→ # 307).

Restarting the drive after changing the SafeID will result in the loss of this default configuration and will cause a non-operational state as long as no other parameter package is downloaded and validated.

Restarting the drive after changing the SafeID in general will invalidate the current safety configuration. Returning the SafeID to the previously configured value afterwards will not revalidate the previously used configuration. In order to use this or another configuration again, a new download and validation of a parameter package is necessary.

NOTE

The SafeID value 00 will also invalidate/clear the safety configuration after a restart but cannot be used as regular value for operation.

The SafeID is calculated based on the rotary switches setting:

$$\text{SafeID} = 10 \cdot \text{S1} + \text{S2}$$

Example:

$$\text{Rotary switches: S1} = 2, \text{S2} = 3 \rightarrow \text{SafeID} = 10 \cdot 2 + 3 = 23$$

Default: When shipped, the SafeID is preset to 01 by default (SafeID = 1). The default safety configuration is bound to this SafeID.

9.5.4 FSoE Node Address

The unique FSoE address for every axis is derived from the set SafeID.

Axis	FSoE address	Minimum FSoE Address	Maximum FSoE Address
1	SafeID • 100 + 1	101	9901
2	SafeID • 100 + 2	102	9902

Example for FSoE address setting:

Rotary switches setting: S1 = 2, S2 = 3 → SafeID = $10 \cdot 2 + 3 = 23$

Resulting FSoE address for axis 1 : $23 \cdot 100 + 1 = 2301$

Resulting FSoE address for axis 2 : $23 \cdot 100 + 2 = 2302$

Default: With default SafeID setting (01) the resulting FSoE addresses are 101/102.

9.5.5 Instances

Many safety functions offer several instances. An instance is an independent, separately selectable and configurable variant of the respective function. The activation source for each instance can be selected individually (safe digital input or FSoE).

Some instances are additionally marked with "Fault Reaction". A "Fault Reaction" can be triggered by safety functions, I/O failures and critical internal failures.

NOTE

SS1 instance 1 and STO are the default fault reactions and cannot be deactivated. Configure these instances accordingly.

9.5.6 WorkBench Safety Function Setup

You can easily configure the safety parameters using KollmorgenWorkBench. The safety parameter configuration, download, and validation are completely integrated.

WorkBench performs a plausibility check which helps to identify improper configurations. If the configuration passes the plausibility check, WorkBench creates a safety parameter file. This file can be downloaded to the drive through WorkBench or it can be exported. Once the safety parameters are configured, downloaded, and validated through WorkBench, the safety configuration will be persistent and no new configuration will be necessary after power cycle.

Preconditions

- AKD2G Service port X20 (→ # 160) is connected through either an Ethernet cable that is directly connected to the computer or to a network switch.
- Auxiliary voltage is connected to the AKD2G's X10 and switched on.
- WorkBench is installed.

Activating a Safety Configuration within the SMM:

1. Configure the safety parameters.
2. Download the safety parameters (→ # 297) to the drive through:
 - WorkBench (Telnet): persistent safety configuration, or
 - EtherCAT (FoE): persistent safety configuration, or
 - EtherCAT (FSoE): non-persistent safety configuration.
3. Validate the safety parametrization.

Possible scenario:

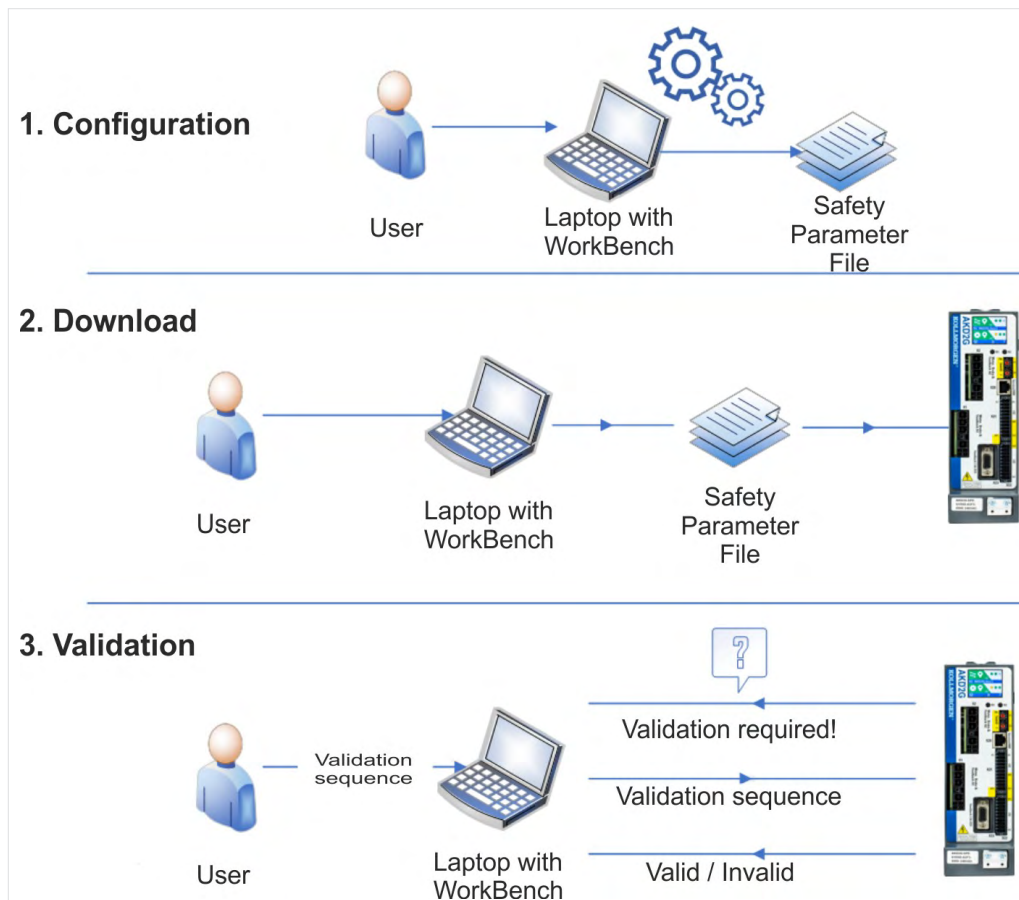

9.5.6.1 Project Building (Online)

The steps below will guide you through project building online.

NOTE: Offline project building is also available and Step 3 shows you where to choose to work either online or offline.

1. Start WorkBench.
2. Under Start, select the **New Project...** link to create a new project.

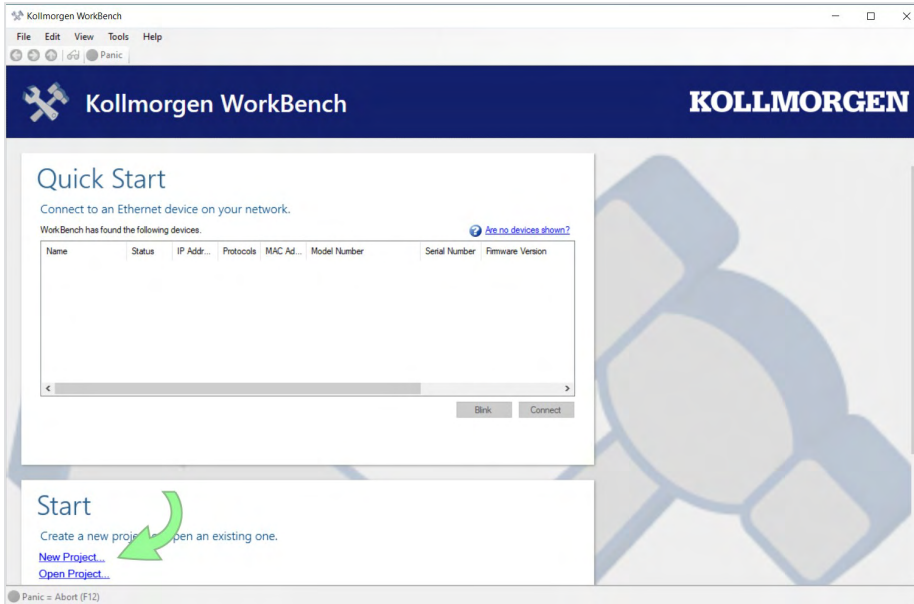

3. Select the **Add New Device** button to add a device to the project. The Add New Kollmorgen Device dialog appears.

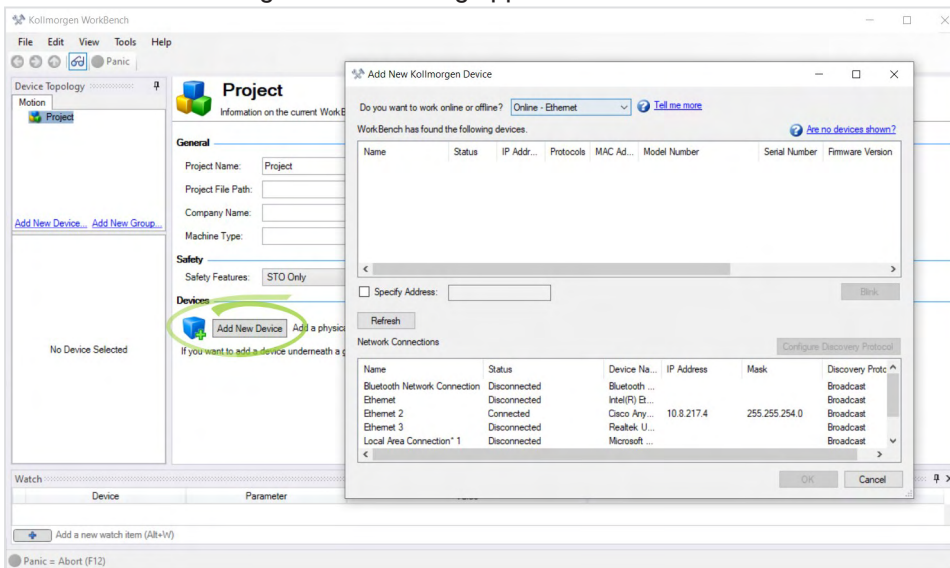

4. Select the device to be added to the project and select **OK**.
5. In the **Safety** tab, under **Device Topology**, select **Project**.

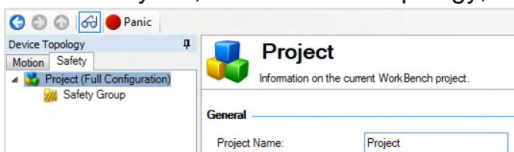

- Under Safety, set the Safety Features drop-down to **Safe Functions**.

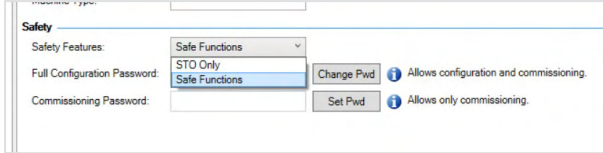

- Set the **Full Configuration Password**.

This password is required to access and edit the safety configuration for the project and to generate safety packages.

Note: A Commissioning Password is not required for safety setup. However, it is required to download and activate a safety parameter set into a device. The access provided by the Commissioning Password does not allow the user to edit safety parameters.

- Under Device Topology, open the **Safety** tab.
- Select the **Safety Group** and change the **Group Name** if required.
- Select the **Available Device** to be added to the Safety Group.

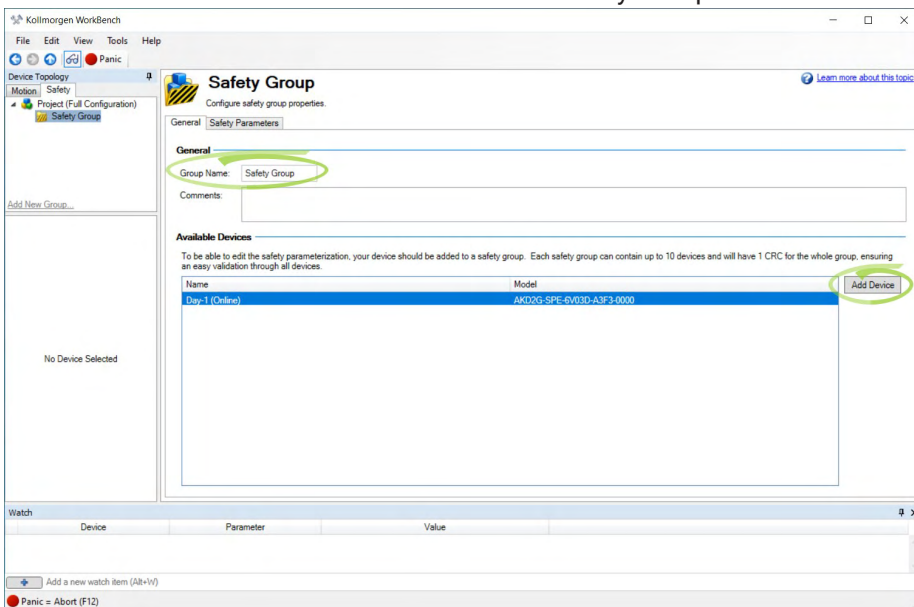

- Select **Add Device** to add the device to the group.
- Under Device Topology select the **Parameters Editor** in order to parameterize the safety functions.

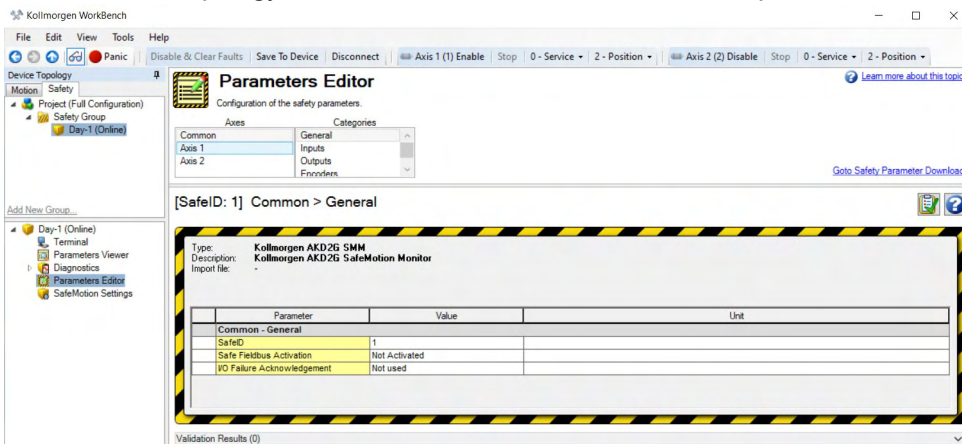

9.5.6.2 Parameters Editor

The Parameters Editor view provides the ability to set up safety parameters and define the safety groups using the options available under Axes, Categories, and other sections that may appear depending on your selection.

Jump to a topic in this section:

- "Common Safety Parameters" (→ # 294)
- "Axis Safety Parameters" (→ # 296)
- "Defining a Parameterization Package" (→ # 296)
- "Viewing, Exporting, or Deleting A Parameterization Package" (→ # 296)

Common Safety Parameters

Common Safety Parameters that may be changed include:

- "General Safety Settings" (→ # 294)
- "Safe Input Settings" (→ # 295)
- "Safe Output Settings" (→ # 295)

General Safety Settings

To access the General safety settings in the Parameters Editor:

1. Under Axes, select **Common**.
2. Under Categories, select **General**.

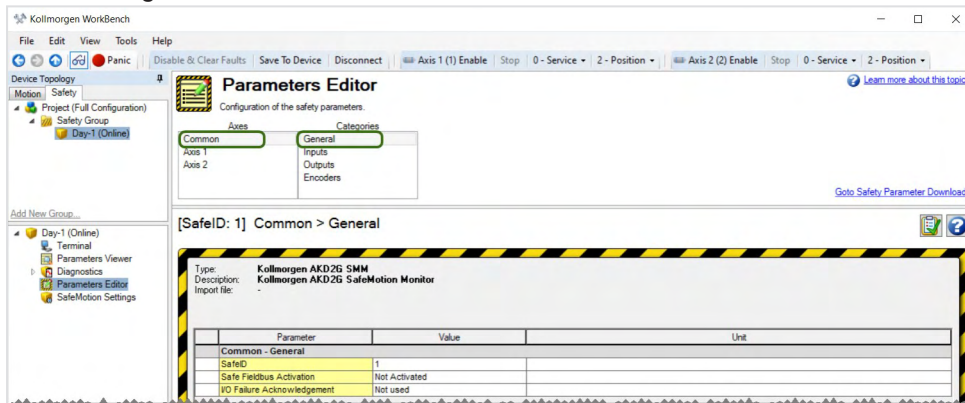

The SafeID (set with the rotary switches on the drive) is visible in the first line.

Safe Input Settings

To access the Safe input settings in the Parameters Editor:

1. Under Axes, select **Common**.
2. Under Categories, select **Inputs**.

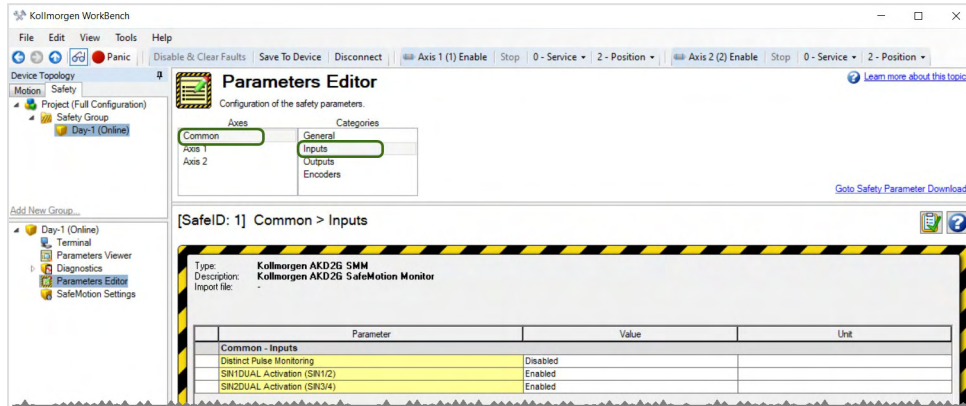

If the application requires dual channel inputs for a safety function, enable the safe input pair to be used. For more information on the SINDUAL# parameters, refer to (SAFEPARAM.SINDUAL#.EN, → # 536).

Safe Output Settings

To access the safe output settings in the Parameters Editor:

1. Under Axes, select **Common**.
2. Under Categories, select **Outputs**.

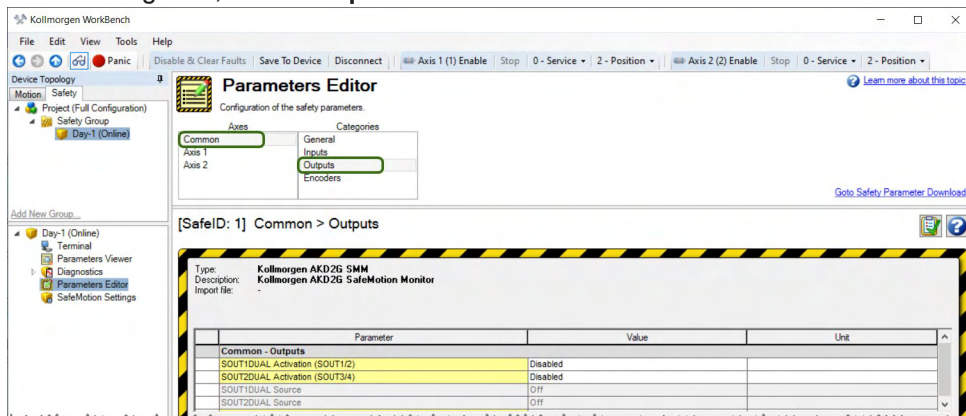

If the application requires dual channel outputs for a status message, enable the output pair to be used. For parameter descriptions, see (SAFEPARAM.SOUTDUAL#.EN, → # 537).

Axis Safety Parameters

To set the axis safety parameters:

1. Choose the Axis.
2. Under Categories, select a category.
3. Under Safe Stop, select the safe function needed.
4. Under Instances, select the Instance Number.

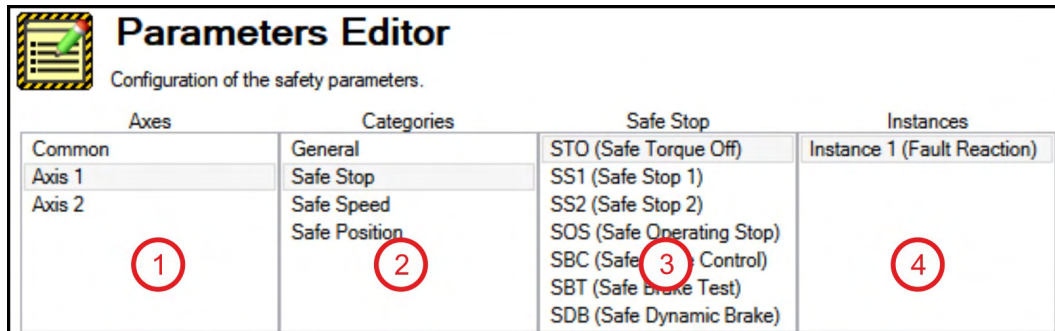

For more information on a specific safety function, (→ # 203). For parameter descriptions, (→ # 315).

Defining a Parameterization Package

A Parameterization Package (or parameter bundle) must be defined after all parameters for all safety functions and devices are set.

To define a Parameterization Package:

1. Select the **Safety** tab under Device Topology and select the **Group Name**.
2. Select the **Safety Parameters** tab for that group.
3. Under Current Configuration, select **New Package**.

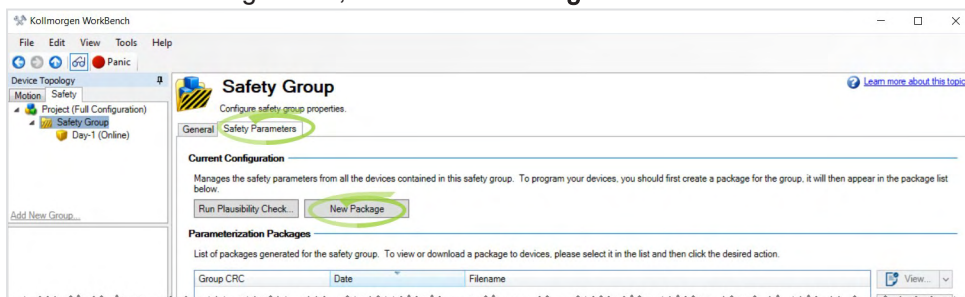

The new package is then listed underneath the Parameterization Packages section.

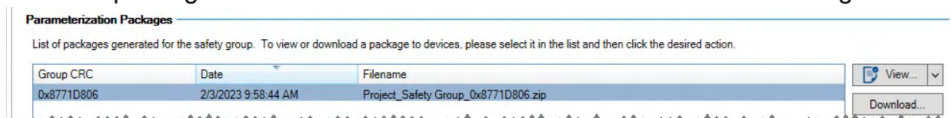

Viewing, Exporting, or Deleting A Parameterization Package

To view the contents of a Parameterization Package:

1. Select the desired package.
2. Select the drop-down arrow next to View.

3. Select View Parameter Report.

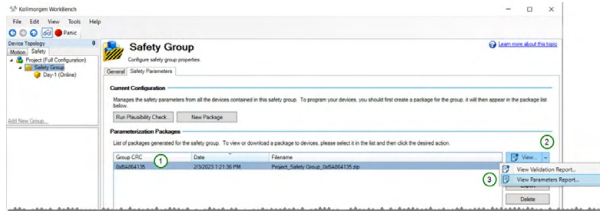

- To save a parameterization package externally, select the package from the list and select **Export**.
- To delete a package, select the package from the list and select **Delete**.

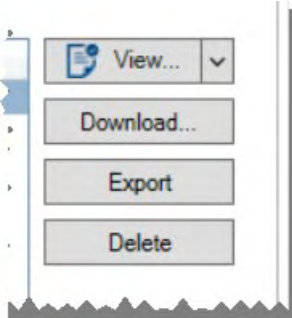

9.5.6.3 Downloading Safety Parameter Packages

This page outlines how to download safety parameter packages created with WorkBench and how to export these packages through EtherCAT FoE and FSoE. If you need help setting up safety parameters, see (WorkBench Safety Function Setup, → # 291).

Downloading Safety Parameter Packages through WorkBench

The following steps outline how to download a safety parameter package using the WorkBench GUI:

1. Go to the **Safety** tab under **Device Topology**. Then, select **Safety Group** under **Project**.
2. In the **Safety Group** view, navigate to the **Safety Parameters** tab, then under **Parametrization Packages**, select the package to be sent to the drive.
3. Select the **Download...** button.

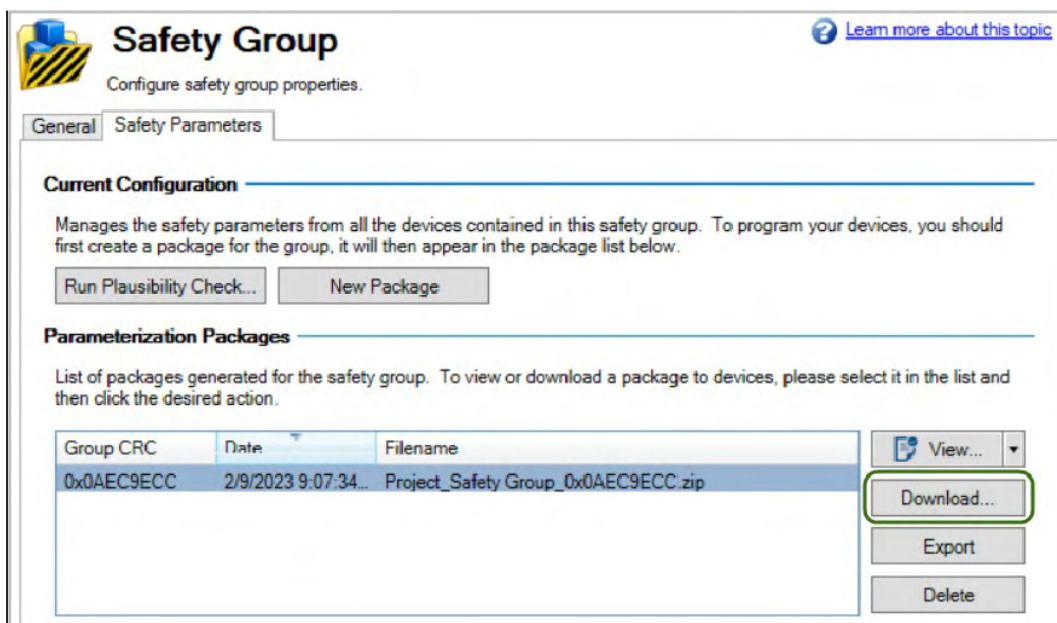

4. A **Safety Parameters Download** window will pop-up after **Download...** is selected. Enter your user name and password under **Download & Verify**.

Any alphanumeric text between 8 and 25 characters can be put in the user name field. The default password is SafeMotionMonitorxyz, where xyz is the last three characters of the drive's serial number. The serial number can be found by entering DRV.INFO in the terminal or by checking the device name plate. If the serial number is R2-2022-00004, the default password is SafeMotionMonitor004.

5. Select the **Download** button to transmit the package to the drive.

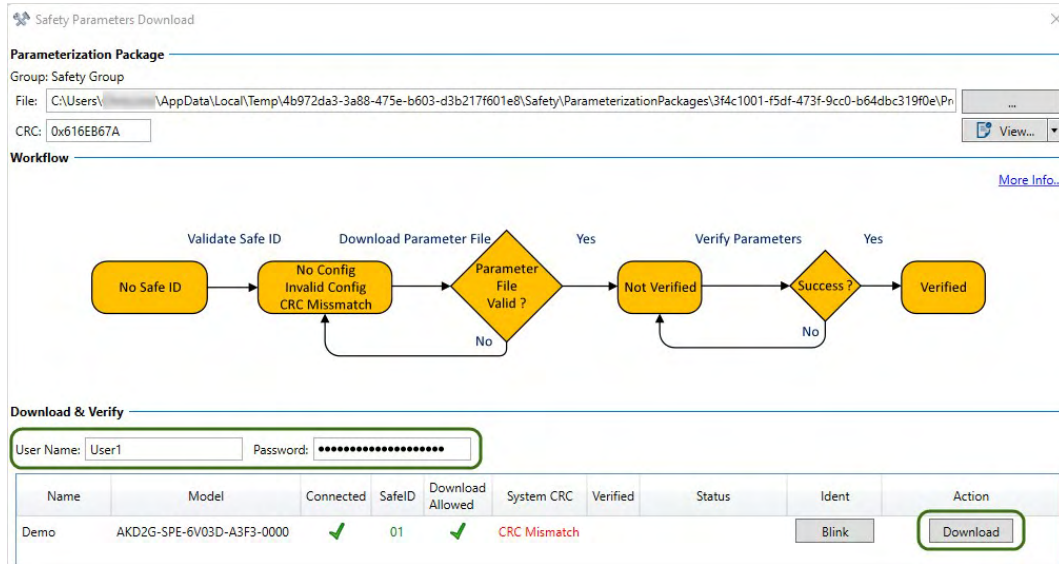

6. Enter the drive's SafeID (1), then select **Verify** (2). This ensures the intended matching parameter package is loaded to the drive.



The safety configuration will be persistent and no configuration is required after power cycle.

Downloading Safety Parameter Packages via FoE

The AKD2G drive allows users to download safety parameter files and validate the safety configuration via the file access over EtherCAT (FoE) protocol.

The following steps outline how to export and download safety parameter packages through FoE:

Step 1: Export the file via FoE

1. Go to the **Safety** tab under **Device Topology** and select the safety group for your project.
2. In the **Safety Group** view, navigate to the **Safety Parameters** tab, then select the safety parameter package to be exported under **Parametrization Packages**.
3. Select the **Export** button.

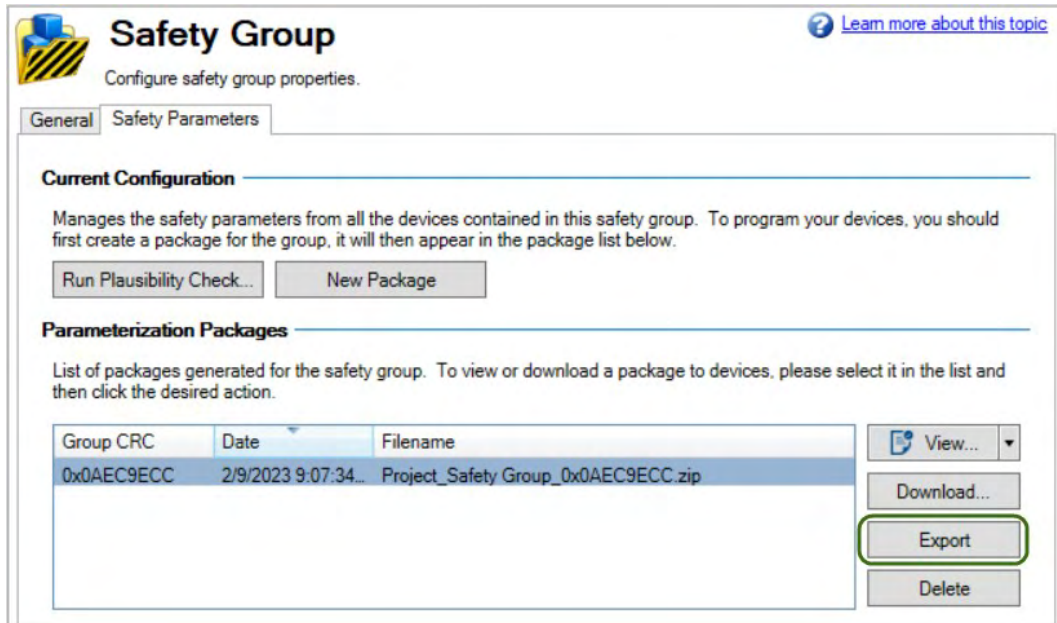

4. After **Export** is selected, a **Save As** window will pop-up. The file must be saved in the **.i00** format.

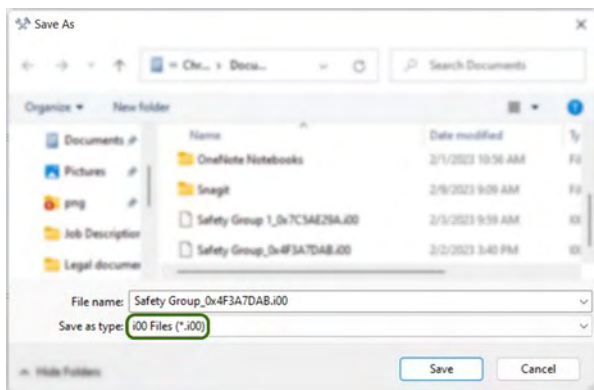

5. The exported file is ready for use by the EtherCAT master for FoE download.

Step 2: Download the file via FoE

The EtherCAT master must set the drive to the "Boot" state before the safety parameter package is downloaded to the drive. Downloading a corrupted or incompatible safety parameter package will generate an FoE error message stating, "Failed loading file to flash", and the SafeMotion Monitor (SMM) will stay in state 3 - Configuration required.

Step 3: Validate the file via CoE and SDO Access

File validation must be done through SDO access if the safety parameters are downloaded through FoE. The SMM (Index: 0x37C1, Subindex: 0x00) will transition from state 3 - Configuration required - to state 5 - Parameter validation required - after the safety parameter package is downloaded. The SMM must be in state 5 for file validation.

NOTE

If the SafeID is set to 1 and the drive still has its default parameter values, you must delete those defaults to proceed. Complete the following steps to transition to state 3:

1. Change the SafeID from 1 to another valid SafeID.
2. Power cycle the drive.
3. Reset the SafeID.
4. Power cycle the drive again.

To validate the downloaded safety parameters, write the CoE objects in the order outlined in the table.

All CoE objects have an index of 0x37C0.

Step	Object	SubIndex	Format	Notes
1	User name	0x01	1 - 8 ASCII characters	<ul style="list-style-type: none"> Enter this object additionally as a string for service personnel who are not familiar with the data. The user name is logged after successful validation.
2	Date and Time	0x02	YYYY-MM-DDThh:mm:ssZ Date: YYYY = year, MM = month, DD = day Time: T = separator, hh = hour, mm =minute, ss =second, Z = time zone designator Example: "2021-03-03T16:10:10Z" is March 3rd, 2021, 16:10:10 UTC	<ul style="list-style-type: none"> Enter this object additionally as a string for service personnel who are not familiar with the data. The timestamp is logged after successful validation.
3	SafelD	0x03	Integer value	<ul style="list-style-type: none"> Enter the SafelD of the device that will be configured.
4	Password	0x04	8 - 25 ASCII characters	<ul style="list-style-type: none"> This is the password that will validate the downloaded safety parameters. Enter this object additionally as a string for service personnel who are not familiar with the data. To change this password, see (SAFE.CHANGEPASSWORD, → # 510)

If the validation is successful, the SMM will transition to state 6 - Normal operation.

If validation fails, the safety configuration will NOT be activated. The SMM will stay in state 5 and the SDO write will return an abort message. If the process fails, refer to (Safety Faults, Safety Warnings, → # 311).

The safety configuration is persistent when downloaded through FoE and is retained after power cycling.

Downloading Safety Parameters via FSoE

The safety parameters can be downloaded via EtherCAT through FSoE (Fail Safe over EtherCAT) using SRA-Parameters (Safety Related Application).

- Configure the SRA parameters in the FSoE-Master and download them to the drive using EtherCAT SDO access and FSoE.
All safety parameters are available in the object dictionary. Default parameter values are found in the ESI file.
- Validate the safety configuration via the FSoE master.
The FSoE master will send the cyclic redundancy check (CRC) to the AKD2G FSoE slaves during startup.
The SMM must be in state 3 - Configuration required - for the validation process to occur. If the validation is successful, the SMM will transition to state 6 - Normal operation. Otherwise, the SMM will stay in state 3.

NOTE

If the drive already has a persistent safety configuration, clear the existing configuration to set the SMM to state 3. See (SafelD, → # 289) for details on clearing the configuration.

The safety configuration is non-persistent when downloaded through FSoE. The configuration will be cleared after a reboot or a FSoE connection reset.

9.5.6.4 Safety Configuration Diagram

A safety configuration diagram displays when you select the **Safety** status button at the bottom of the WorkBench window. The diagram shows the safety state and the relationship between safety functions. If an error occurs, reference the CANopen object dictionary for more information(see CANopen Object Table).

9.5.6.5

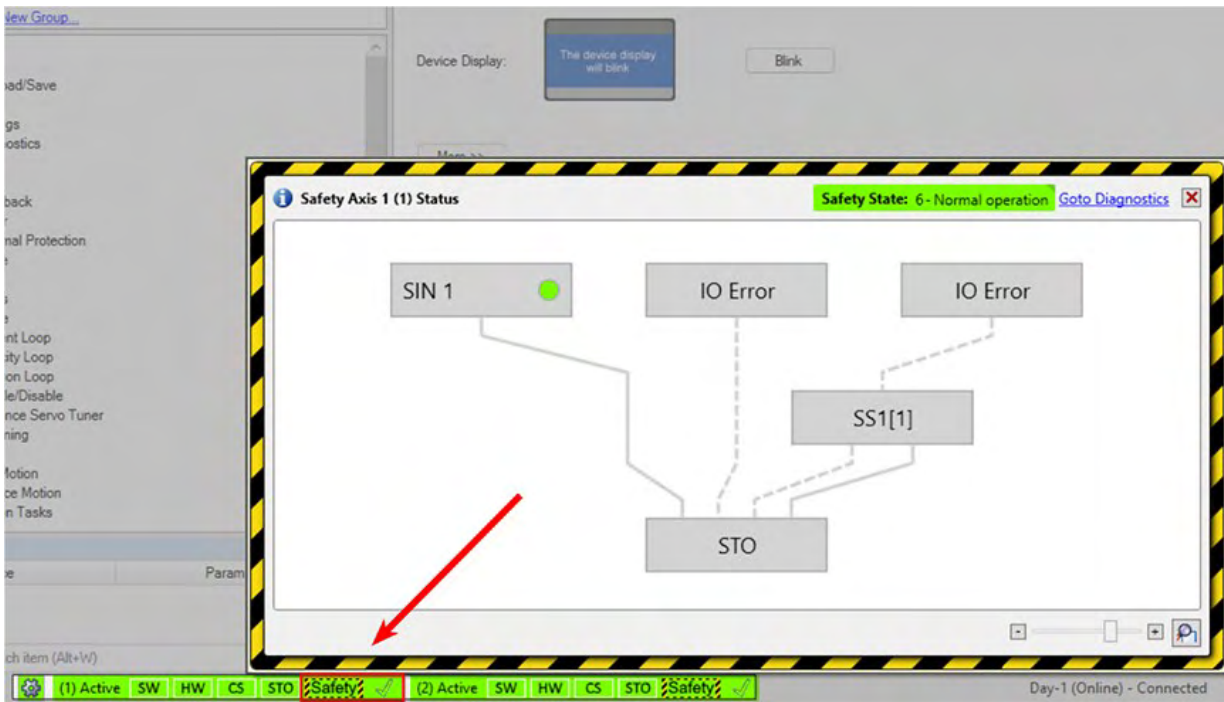

Parameters Viewer

The **Parameters Viewer** is located in the View Tree under the **Safety** tab. Select the **Parameters Viewer** to display the actual values of all safety parameters activated in the drive.

9.5.6.6 Diagnostics

For help with fine-tuning, debugging, and verification of your safety project, WorkBench Diagnostics offers live information about internal safety related values.

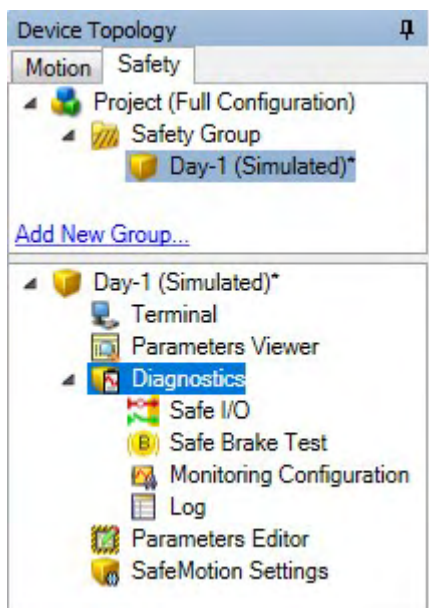

Diagnostics

This view offers information about the SMM and the overall safety system status, such as:

- SMM Hardware Revision and Firmware Version
- Safe ID and System CRC
- Active errors and object instances of errors
- Safe fieldbus status

Safe I/O

This view displays the current configuration and values of the safe I/Os. It includes the dual configuration information for inputs and outputs and the source of the output signal.

Safe Brake Test

This view displays the current safe brake configuration with the test status including the time remaining to the next test. The safe brake test can also be started and monitored within that view.

Monitoring Configurations

This view has information concerning function states, safe velocity, safe position and safe acceleration can either be monitored directly or added to the Watch Panel for permanent surveillance or added to the WorkBench internal oscilloscope. A maximum of two values can be observed simultaneously.

Log

This view displays the log stored in the SMM. All actions related to SafeID and parameter validation are logged with user name and date.

9.5.6.7 SafeMotion Settings

SafeMotion Settings allows you to set a specific user parametrization password for parameter validation. The root safety password is used as default. It is recommended you change your password after initial use. For more information, see (Commissioning, → # 201).

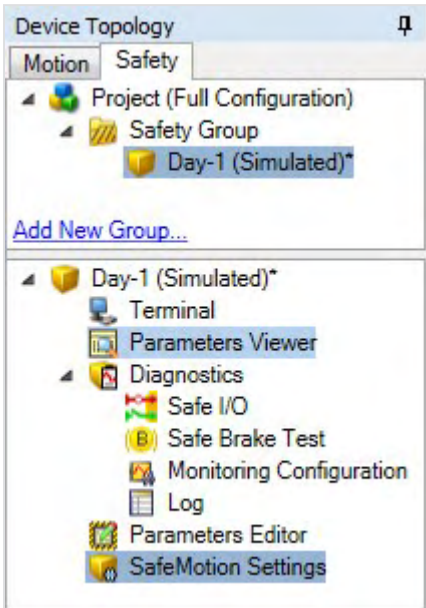

9.5.7 Parameterization of User Units

Position, velocity, and acceleration values are computed and stored in increments (also known as counts) in the SafeMotion Monitoring (SMM). These values are presented in user units so that they are understandable in the parameterization and in different diagnostic elements.

The conversion is done in two steps:

1. Increments \Leftrightarrow Encoder Unit
2. Encoder Unit \Leftrightarrow User Unit

This two step conversion allows you to simply enter the encoder specification and the conversion from a known unit to your desired unit.

Rotary Encoder Example

Rotary encoders are usually defined by the number of increments per revolution. The user unit can be defined in relation to 1 revolution.

The following example shows a conversion from increments to degrees:

1. 2048 increments \Leftrightarrow 1 rev
2. 1 rev \Leftrightarrow 360 degrees

9.5.7.1 Encoder Settings

Select Encoder (Common/Encoders)

Select an encoder type to configure the unit ratio. The SMM will complete the calculations using internal data. For information on the encoder setup, see (→ # 216).

Name	Default	Parameter
Encoder 1 (HF-DSL)	0 (Not used)	(→ # 530)
Encoder 2 (HF-DSL)	0 (Not used)	(→ # 531)

Connect Encoder to an Axis (Axis/General/Encoder)

For each axis the user plans to use a safe encoder with, it is required to define which encoder is used and how it is used.

Name	Default	Parameter
Encoder Source	0 (No encoder)	(→ # 392)
Speed Computation Interval	1 ms	(→ # 457)
Acceleration Computation Interval	1 ms	(→ # 390)
Absolute Position	0 (Disabled)	(→ # 386)
Absolute Position Range	0 (Unsigned)	(→ # 387)
Absolute Position Reset Value	0 Pos User Units	(→ # 389)
Absolute Position Reset Source	0 (Not Used)	(→ # 388)

The intervals define a filter on the positions read to compute the velocity and the acceleration. These parameters influence the response time of the computed velocity and acceleration. The larger these values are, the longer the lag will be.

9.5.7.2 Encoder Unit <=> User Unit

The user must define four parameters for each unit type to configure the unit ratio. Two of the four parameters are used for ratio computing, and two are defined to improve usability but are not used in the computation.

The computation ratio is defined by the:

- Number of increment for the value (pos/vel/acc) in the encoder unit
- Number of increment for the value (pos/vel/acc) in the user unit

For example:

- 1 [rev] / 1 [rev/s] / 1 [rev/s²]
- 360 [deg] / 60 [RPM] / 60 [RPM/s]

The SMM only supports integer values. If you want to have one decimal, you must compute your ratio accordingly and use a deci factor on the unit, and similarly for more decimals (cent, milli, ...).

Name	Default	Parameter
Acceleration factor unit	5	(→ # 495)
Acceleration incr. in encoder units	1	(→ # 496)
Acceleration incr. in user units	60	(→ # 497)
User dimension for acceleration	5	(→ # 498)
Position factor unit	4	(→ # 499)
Position incr. in encoder units	1	(→ # 500)
Position incr. in user units	3600	(→ # 501)
User dimension for position	4	(→ # 502)
Velocity factor unit	5	(→ # 503)
Velocity incr. in encoder units	1	(→ # 504)
Velocity incr. in user units	60	(→ # 505)
User dimension for velocity	5	(→ # 506)

9.5.7.3 User Units Scaling

WorkBench displays all the computation related to the units.

User Units Scaling (for information only)	Resolution (for information only)
Encoder: N/A	Pos: N/A
Pos: N/A	Vel: N/A
Vel: N/A	Acc: N/A
Acc: N/A	

These computations are not safe - the ratio must be calculated and verified by the user. WorkBench shows these values for convenience only.

- Encoder: describes the Increments \Leftrightarrow Encoder Unit conversion ratio.
- Pos/Vel/Acc : describes the Encoder Unit \Leftrightarrow User Unit conversion ratio.
- Resolution : indicates the minimum resolution for 1 count (for example: 0.027 ddeg, respectively 0.0027 degree).

9.6 Validation

Validation is done on transferred parameters using CRC. Parameters transferred with FSoE (when FSoE parametrization is used) do not require user validation.

More information referring to parameter download (→ # 297).

9.6.1 Validation of SafeID

If the SafeID is not flagged as validated when booting, you will get the message: "SafeID not validated" . Then do the following:

1. Compare the displayed SafeID with the paperwork.
2. If the SafeID is correct, press button B2 twice within 10 seconds to validate. If you do not press B2, the drive remains in the safe state.

Validation of the SafeID is performed through FSoE

- if FSoE parameterization is used and
- if the SafeID is not validated yet and
- if the SafeID matched the safe address defined in the safe PLC.

9.6.2 Validation of Safety Parameters

NOTE

The parameter CRC is equal to the system CRC. The character string of the SafeID is concatenated with the character string of the CRC.

The purpose of validation is to ensure that all safety parameters as a group are suitable for the application.

Example for invalid parameters: The parameters are valid for an elevator drive, but they are not for a paper machine drive.

The person responsible for validation must document decisions. Therefore the safety related system stores information about the user (user name, date of validation).

- The user checks the System CRC. This value is read from the drive (see parameter value [SAFE.CRC](#)). This may require the user to sign a document about the correct parameters having been entered.
- The user must check if all drives have been programmed correctly.

9.6.3 Validation of Safe I/O Installation

The person conducting the validation must be independent of the Safety Function Design. See ISO 13849-2:2012, 4.1 Validation principles.

9.6.4 Validation Report

To assist commissioning and documentation, WorkBench offers to print a “Safe Motion Validation Report” suiting the safety parameter configuration. Select the corresponding safety parameter package (1). To view the validation report, click on “View” (2) directly or “View Validation Report” (3).

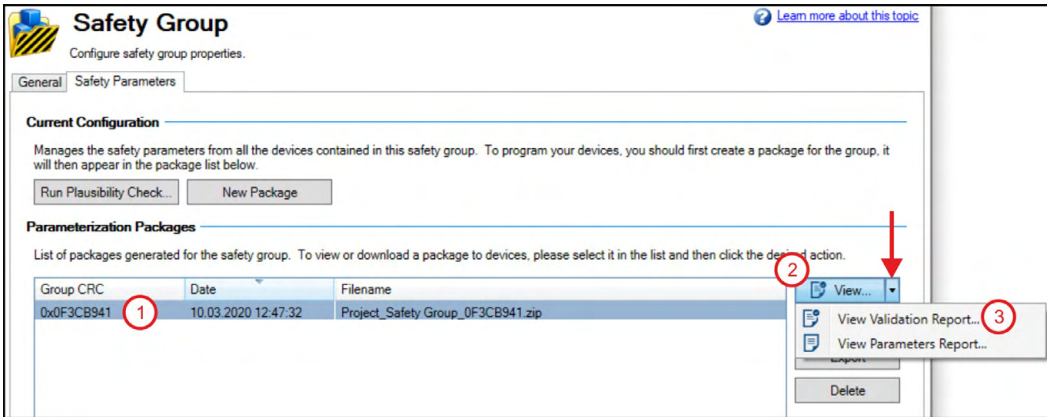

The “Safe Motion Validation Plan” lists all configured functions and their parameterized values (expected behavior). The validators can use it as guidance to verify all parameters and functions.

Example for a Validation Report (extract):

KOLLMORGEN		2020.01.22
AKD Safe Motion Validation Report Machine Related Information		
General Information:		
Project name	Project Demo	
Safety group	Demo Group	
Company name	Kollmorgen	
Validator 1		
Validator 2		
Machine type	Demo Machine	
Comments	Demonstration for a possible Validation Report	
Project and Components:		
Source project filename	Project Demo.wbp	
Safety package filename	Project Demo_Demo Group_A3157E81.zip	
CRC for the safety group	0xA3157E81	
Safe ID	23	
Device name	Demo	
Device model	AKD2G-SFE-6V06D-A2F3-0000	
Safety License	Basic Safety Features	
Axes		
Axis 1 Safe Encoder	No Encoder	
Axis 2 Safe Encoder	No Encoder	
Validator 1:	<input type="text"/>	Validator 2: <input type="text"/> 1 of 5

KOLLMORGEN		2020.01.22	
Safe ID 23 - STO (Safe Torque Off)			
Analysis of STO (Safe Torque Off) for device with Safe ID 23 (no_name)			
Parameter	Value	Results	
Axis 1 - Safe Stop - STO - Instance 1 (Fault Reaction)			
Function Activation	Ready for Activation	<input type="checkbox"/> OK <input type="checkbox"/> Not OK	
Safe Input	Not Used	<input type="checkbox"/> OK <input type="checkbox"/> Not OK	
FSOE	Not Used	<input type="checkbox"/> OK <input type="checkbox"/> Not OK	
Restart Acknowledge Behavior	Manual Restart	<input type="checkbox"/> OK <input type="checkbox"/> Not OK	
Restart Acknowledge Source	Safe input 3 (SIN3)	<input type="checkbox"/> OK <input type="checkbox"/> Not OK	
Axis 2 - Safe Stop - STO - Instance 1 (Fault Reaction)			
Function Activation	Ready for Activation	<input type="checkbox"/> OK <input type="checkbox"/> Not OK	
Safe Input	Safe dual input 1 (SIN1/SIN2)	<input type="checkbox"/> OK <input type="checkbox"/> Not OK	
FSOE	Not Used	<input type="checkbox"/> OK <input type="checkbox"/> Not OK	
Restart Acknowledge Behavior	Manual Restart	<input type="checkbox"/> OK <input type="checkbox"/> Not OK	
Restart Acknowledge Source	Safe input 4 (SIN4)	<input type="checkbox"/> OK <input type="checkbox"/> Not OK	
Test of STO (Safe Torque Off) for device with Safe ID 23 (no_name)			
Step	Required Action	Expected Behavior	Results
Axis 1 - Safe Stop - STO - Instance 1 (Fault Reaction)			
1	Move axis forward or backward.	Axis is moving.	<input type="checkbox"/> OK <input type="checkbox"/> Not OK
2	Activate STO on axis.	STO is activated on the axis.	<input type="checkbox"/> OK <input type="checkbox"/> Not OK
3	Check movement.	Axis is stopped, no movement.	<input type="checkbox"/> OK <input type="checkbox"/> Not OK
Axis 2 - Safe Stop - STO - Instance 1 (Fault Reaction)			
1	Move axis forward or backward.	Axis is moving.	<input type="checkbox"/> OK <input type="checkbox"/> Not OK
2	Activate STO on axis.	STO is activated on the axis.	<input type="checkbox"/> OK <input type="checkbox"/> Not OK
3	Check movement.	Axis is stopped, no movement.	<input type="checkbox"/> OK <input type="checkbox"/> Not OK
Validator 1:	<input type="text"/>	Validator 2: <input type="text"/> 3 of 5	

9.7 Operation

NOTICE

After the initial commissioning and validation, it must be ensured the initial state is permanently retained. Modification of any kind is prohibited without a proper modification process.

In case of a fault reaction occurring (STO-, SS1- or SS2-Active without being activated on purpose) the drive should not be restarted before:

- the cause of the fault reaction is investigated and found;
- the reason of the fault reaction is removed/resolved;
- safe operation of the application is ensured.

Every occurring incident must be documented.

If the investigation of the fault reaction results in the discovery of a potential hazard or risk the application shall not return to normal operation before proper risk reduction is achieved.

In order to maintain functional safety, safety chains containing elements that cannot be tested regularly or without activation during normal operation, need to be periodically tested at least:

- once per year for SIL 2, PL d / Cat. 3;
- once every three months for SIL 3, PL e / Cat. 3;
- once every day for SIL 3, PL e / Cat. 4.

See IEC 61800-5-2 and ISO 13849 for further information.

In addition, tests for brakes need to be carried out independently (SBT (Safe Brake Test), → # 249).

The drive itself does not require any maintenance (Maintenance and Cleaning, → # 32).

Replacement is only necessary in case of a defect or if the max. service life of the device (Mission Time, TM) is exceeded (Field Replacement, → # 310).

Wear parts of safety chains such as relays, brakes or SDB-Contactors, need to be swapped at the end of their lifetime as well as damaged or defect auxiliary equipment.

The replacement of any parts of the safety chain does not allow any changes or modifications to the safety characteristics or functionality of a safety chain. A new validation of the safety functions is necessary after working on any safety related equipment. In case of a modification a risk reevaluation and modification process needs to be carried out before retuning the drive to normal operation.





Every maintenance activity must be documented.

Periodic audits have to be carried out and documented in order to ensure the functional safety of the machine.

Check the drives information display for faults and warnings regularly.

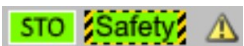
9.7.1 Operation States

The status bar in WorkBench offers a brief overview of the safety operation status.

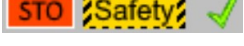
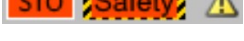
Safety bar indicator	Status
	Axis is in normal operation from the safety system perspective. No safety functions are active.
	Axis is in normal operation from the safety system perspective. No safety functions are active. A non-safety relevant warning is active.
	Axis is in normal operation from the safety system perspective. A non-safe error prevents non-safe operation.
	
	Axis is in normal operation from the safety system perspective. One or more safety functions are active, such as SOS or SLS.
	Axis is in normal operation from the safety system perspective. STO is active.
	Drive is in safe state due to an internal failure or an I/O failure in the safety system. Normal operation is prevented.

Clicking on the safety symbol will open a pop-up window containing more detailed information on the safety configuration and status (→ # 301). The view give information about which function(s) are or were activated, and which caused a fault reaction.

9.7.2 Field Replacement

NOTICE

Field replacement must be performed by a trained and qualified personnel. After the drive is replaced and re-configured, the drive must be verified and proof tested before normal operation is started.

The replacement drive must

- match the specification of the replaced drive in term of voltage, features and safety option, see "Part Number Scheme" (→ # 37),
- contain firmwares with same versions, particularly for the SMM. If not, a firmware upgrade or downgrade must be performed, see (Updating the SMM Firmware, → # 199),
- have invalidated safety parameters.

Reconfiguring the replacement drive:

- Other drives of the same safety group or of the same machine should not be impacted by this process.
- Before power on, the replacement drive SafeID must match the one of the replaced drive. Change the rotary switches accordingly.
- Validate the new SafeID if needed during the boot of the drive, see "Validation" (→ # 307).
Important: Configure and validate the SafeID before downloading new parameters.
- Download safety parameters on the replacement drive. SafeID value is used to choose the right set of parameters for this drive (see "Downloading Safety Parameter Packages" (→ # 297)). Depending on your application, this could be:
 - using WorkBench. Use the project of your safety application to download the parameters,
 - using non-safe field bus,
 - using FSoE.
- Validate that the correct parameters have been downloaded by comparing the CRC, see "Validation of Safety Parameters (→ # 307)

9.8 Safety Faults, Safety Warnings

9.8.1 LCD Display

The drive offers an LCD display and two push-buttons, B1 and B2, for navigation.

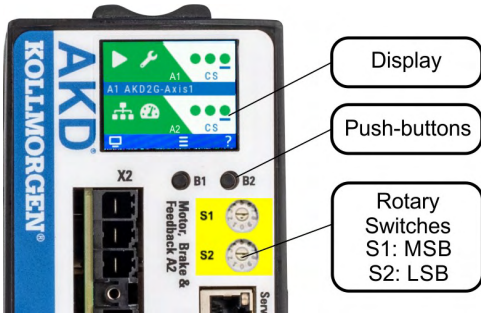

The display on the front panel of the drive shows the code of the fault or warning that occurred. Safety Faults and Warnings follow the same pattern and are identified by a four digit code 90 XX, where 90 is the two digit group code, and XX is a two digit ID.

Navigate with B1 / B2 to the Fault screen to see a short description of the fault or warning. See WorkBench Online Help for details.

Example: dual axes, Fault Axis 2

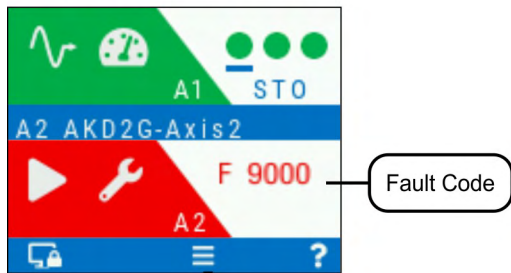

Example: single axis, Warning Axis 1

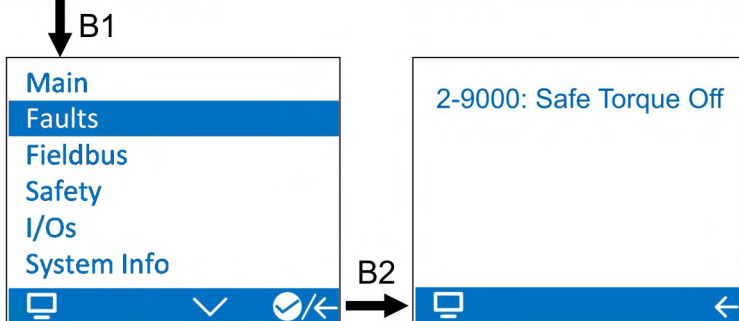
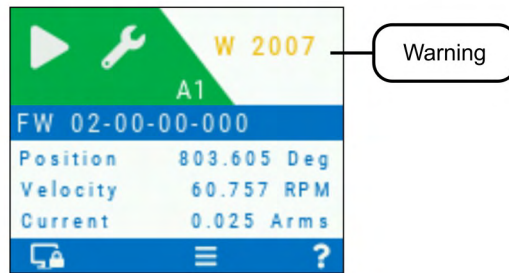

9.8.2 Failure Categories

AKD2G with SMM (safety option 2 or 3) have the following safety circuit fault states:

Failure category	Description	Reaction
1	I/O Failure A problem is detected around the drive. Example: encoder problem, missing OSSD test pulses or a wiring issue. Resolving: by the user or by using FSoE Restart: acknowledge fault, power off/on, normal operation can be resumed.	If the velocity is >0, SS1_1 is activated. The axis executes a controlled stop.
2	Internal failure The drive detected a problem in the drive or in the internal SMM itself. The problem prevents further normal operation, but allows to transmit diagnostic data for diagnosis. Example: problem in switching the brake output. Resolving: power off/on Restart: not possible unless fault is removed.	If the velocity = 0, the drive applies the brake and activates SS1 or STO.
3	Internal failure, reset may occur The drive detected an internal problem, that may result in resets, and other erroneous behavior. As further operation cannot be executed safely, all communication is dropped. Resets of the internal SMM may occur. Example: RAM failure. Resolving: power on/off Restart: not possible unless fault is removed.	Safe outputs are switched off.

NOTE

An internal failure occurs, when a problem in the internal SMM is detected. Therefore, deceleration, applying the brakes and switching off the output may not be possible under all circumstances. Safety Faults and Safety Warnings cannot be muted or suspended.

Stuck at faults on the STO output, the digital outputs or the brake output show up as I/O failures or internal failures. Power supply faults (over and under voltage) show up as internal or fatal failure. Many diagnostic errors are false positives.

The fault tolerance time for each diagnostic measure (diagnostic test interval) is maximum $T_2 = 1$ h.

9.8.3 SMM Failure Classification and Behavior

The parameter [SAFE.ERROR](#) gives the current error code of the SMM, accessible through CoE.

[SAFE.ERRORINSTANCE](#) indicates the current instance of the error code.

The SMM send the failure ID to the drive, if possible. The drive creates faults and warnings listed in the next chapter.

9.8.4 Drive Safety Faults

NOTE

More information about drive fault messages, remedy and clearing faults can be found in the WorkBench User Manual.

Fault	Description	Cause	Remedy
F9000	Safe Torque Off	STO function has been triggered while the axis is enabled.	See (STO (Safe Torque Off), → # 219)
F9002	SMM communication failed	SMM not communicating as expected	Restart drive. If issue persists, contact technical support.
F9003	Incorrect safety card detected	Physical SMM does not match the expected module	Restart drive. If issue persists, return hardware to supplier.
F9004	Safe Torque Off digital and analog lines don't match	Hardware fault on the power board.	Restart drive. If issue persists, contact technical support.
F9006	Internal failure of the SMM	See SAFE.ERROR and SAFE.ERRORINSTANCE .	Restart drive. If issue persists, contact technical support.
F9007	Safe brake parameters inconsistent	AXIS#.SAFEPARAM.SBC , BRAKE#.ATTACHED indicates a brake is attached, but non-safe brake parameters (AXIS#.MOTOR.BRAKE , BRAKE#.Axis) do not.	From the safety parameter screen in WorkBench under safe brake control (SBC), verify that the SBC Brake parameters agree with the drive related parameters that a brake is either configured or not.

9.8.5 Safety Warnings

NOTE

More information about drive warnings can be found in the WorkBench User Manual.

Warning	Description	Cause	Remedy
W9000	Safe Torque Off	STO function has been triggered.	See (F9000 , → # 313)
W9007	Safe brake parameters inconsistent	AXIS#.SAFEPARAM.SBC , BRAKE#.ATTACHED indicates a brake is attached, but non-safe brake parameters (AXIS#.MOTOR.BRAKE , AXIS#.BRAKE) do not.	From the safety parameter screen in WorkBench under safe brake control (SBC), verify that the SBC Brake parameters agree with the drive related parameters that a brake is either configured or not.
W9008	Safe Brake Test Time Overflow	No SBT has been executed within the configured time limit	Extend SBT limit or execute an SBT
W9009	SMM Over Temperature	SMM is over temperature	Make sure that the ambient temperature complies with the specified limits for the given hardware (Ambient Conditions, Ventilation and Mounting Position, → # 43). If the problem persists, return hardware to manufacturer.
W9010	SMM State not operational	SMM is not ready to enable. Refer to SAFE.STATE .	Verify SafeID and safe parameters are validated and correct. Check for other faults on the SMM.
W9011	SMM I/O failure detected	SMM detected a safety I/O failure and prohibits operation. <ul style="list-style-type: none"> Digital inputs or outputs failed STO pulse failed Brake output failed Encoder safe position failure Invalid Encoder association 	Use diagnostics to determine cause and replace external hardware if issue reoccurs. I/O failure can be acknowledged with FSoE or a safe input (configurable).

9.8.6 Troubleshooting Functional Safety

NOTICE

Eliminate errors and faults in compliance with work safety rules. Troubleshooting only by qualified and trained staff.

Problem	Possible Causes	Remedy causes
A group "90" safety fault or safety warning message is visible in the drive LCD display	Refer to the Drive Safety Fault and Warning tables (→ # 313).	
A fault or warning message of another group than "90" is visible in the drive LCD display	Refer to the drive fault and drive warnings tables (→ # 191) and more detailed descriptions in the WorkBench User Manual.	
Safety faults and warnings are not visible/reported	AXIS#.SAFE.STO.REPORTFAULT is set to 0	Set AXIS#.SAFE.STO.REPORTFAULT to 1
STO cannot be deactivated (no torque)	<ol style="list-style-type: none"> External safety device defective. STO wiring defective. Auxiliary voltage low. STO inputs defective. F9004 visible F9005 visible. 	<ol style="list-style-type: none"> Check external safety device. Check STO wiring for short-circuit or similar. Check voltage level (→ # 210) . Send drive to manufacturer for repair. Send drive to manufacturer for repair. Check safety hardware system. Check safety controller. Check external safety device.
Drive does not enable	<ol style="list-style-type: none"> STO is still active. 	<ol style="list-style-type: none"> Deactivate STO prior to HW Enable.
SS1-t does not execute till the end of the configured time	Non-safe emergency timeout interrupts the deceleration ramp of SS1-t.	Set emergency-timeout to a higher value than t_SS1
Safety parameter package cannot be downloaded. Error messages: <ul style="list-style-type: none"> "The parameter set does not contain parameters for this device." "Parameter does not exist." "Loading file to flash has failed." 	The SafeID set in configuration does not match the SafeID set on the target Device.	Either parametrize the correct SafeID in the parameters or change the SafeID on the desired drive to the configured value, restart and validate the SafeID.
Monitoring configuration: Monitoring field can not be added to the scope	All sources of the scope are already occupied.	Remove at least one source / slot in the scope and try again. Then add the desired monitoring field to the scope.

9.9 Functional Safety Parameter Reference

Abbreviations

- Acc. = Access: RO = Read Only, RW = Read/Write, WO = Write Only
- N/A = Not Available, Y = Yes, N = No
- Vel Unit = Velocity User Units, Acc Unit = Acceleration User Units, Dec Unit = Deceleration User Units, Pos Unit = Position User Units
- Parameters are sorted alphanumerically

Parameters related to safety functions	Acc.	Default	Parameter Package	CAN over EtherCAT			FSoE Object
				Axis1 Index 0x....	Axis2 Index 0x....	Sub	
AXIS#.SAFE.ABSOLUTEPOSITION	RO	N/A	N/A	6611	6E11	0	Y
AXIS#.SAFE.ABSOLUTEPOSVALID	RO	N/A	Safety	N/A	N/A	N/A	Y
AXIS#.SAFE.ACCELERATION	RO	N/A	N/A	N/A	N/A	N/A	N
AXIS#.SAFE.BRAKE#.STATE	RO	N/A	N/A	N/A	N/A	N/A	N
AXIS#.SAFE.ERROR.ACTIVE	RO	N/A	N/A	N/A	N/A	N/A	N
AXIS#.SAFE.FSOE.APPLPARAMLENGTH	RO	N/A	N/A	E901	E911	8	N
AXIS#.SAFE.FSOE.COMMPARAMLENGTH	RO	N/A	N/A	E901	E911	7	N
AXIS#.SAFE.FSOE.CONNECTIONID	RO	N/A	N/A	E901	E911	3	N
AXIS#.SAFE.FSOE.CONNECTIONTYPE	RO	N/A	N/A	E901	E911	6	N
AXIS#.SAFE.FSOE.LASTEROR	RO	N/A	N/A	N/A	N/A	N/A	N
AXIS#.SAFE.FSOE.PROTOCOLVERSION	RO	N/A	N/A	E901	E911	1	N
AXIS#.SAFE.FSOE.SAFETYADDR	RO	N/A	N/A	E901	E911	2	N
AXIS#.SAFE.FSOE.SRACRC	RO	N/A	N/A	E901	E911	9	N
AXIS#.SAFE.FSOE.STATE	RO	N/A	N/A	N/A	N/A	N/A	N
AXIS#.SAFE.FSOE.WATCHDOGTIME	RO	N/A	N/A	E901	E911	4	N
AXIS#.SAFE.FUNCTIONGRAPH	RO	N/A	N/A	N/A	N/A	N/A	N
AXIS#.SAFE.FUNCTIONSTATUS	RO	N/A	N/A	N/A	N/A	N/A	N
AXIS#.SAFE.POSITION	RO	N/A	N/A	N/A	N/A	N/A	N
AXIS#.SAFE.RESTARTACK.REQUESTED	RO	N/A	N/A	N/A	N/A	N/A	N
AXIS#.SAFE.SAR_#.ACTIVE	RO	N/A	N/A	66C7	6EC7	Inst1: 1 Inst2: 2 Inst3: 3	Y
AXIS#.SAFE.SAR_#.INTERNALSTATE	RO	N/A	N/A	N/A	N/A	N/A	N
AXIS#.SAFE.SBC.ACTIVE	RO	N/A	N/A	2061	2161	0	Y
AXIS1.SAFE.SBT.ERROR	RO	N/A	N/A	40F1	-	1	N
AXIS2.SAFE.SBT.ERROR	RO	N/A	N/A	-	40F1	2	N
AXIS1.SAFE.SBT.MOVE	WO	N/A	N/A	2FC0	-	1	N
AXIS2.SAFE.SBT.MOVE	WO	N/A	N/A	-	2FC0	2	N
AXISx.SAFE.SBT.SBA.ACTIVE	RO	N/A	N/A	2060	2161	0	Y
AXIS1.SAFE.SBT.STATE	RO	N/A	N/A	40F0	-	1	N
AXIS2.SAFE.SBT.STATE	RO	N/A	N/A	-	40F0	2	N
AXIS#.SAFE.SCA_#.INRANGE	RO	N/A	N/A	66E8	6EE8	Inst1: 1 Inst2: 2 Inst3: 3	Y

Parameters related to safety functions	Acc.	Default	Parameter Package	CAN over EtherCAT			FSoE Object
				Axis1 Index 0x....	Axis2 Index 0x....	Sub	
AXIS#.SAFE.SCA_#.INTERNALSTATE	RO	N/A	N/A	N/A	N/A	N/A	N
AXIS#.SAFE.SDIn_#.INTERNALSTATE	RO	N/A	N/A	N/A	N/A	N/A	N
AXIS#.SAFE.SDIn_#.MOTIONACTIVE	RO	N/A	N/A	66DF	6EDF	1	Y
AXIS#.SAFE.SDIp_#.INTERNALSTATE	RO	N/A	N/A	N/A	N/A	N/A	N
AXIS#.SAFE.SDIp_#.MOTIONACTIVE	RO	N/A	N/A	66DE	6EDE	1	Y
AXIS#.SAFE.SLA_#.ACTIVE	RO	N/A	N/A	206F	216F	1	Y
AXIS#.SAFE.SLA_#.INTERNALSTATE	RO	N/A	N/A	N/A	N/A	N/A	N
AXIS#.SAFE.SLI_#.ACTIVE	RO	N/A	N/A	66BF	6EBF	Inst1: 1 Inst2: 2 Inst3: 3	Y
AXIS#.SAFE.SLI_#.INTERNALSTATE	RO	N/A	N/A	N/A	N/A	N/A	N
AXIS#.SAFE.SLP_#.ACTIVE	RO	N/A	N/A	66A0	6EA0	Inst1: 1 Inst2: 2 Inst3: 3	Y
AXIS#.SAFE.SLP_#.INTERNALSTATE	RO	N/A	N/A	N/A	N/A	N/A	N
AXIS#.SAFE.SLS_#.ACTIVE	RO	N/A	N/A	669F	6E9F	Inst1: 1 Inst2: 2 Inst3: 3	Y
AXIS#.SAFE.SLS_#.INTERNALSTATE	RO	N/A	N/A	N/A	N/A	N/A	N
AXIS#.SAFE.SOS_x.ACTIVE	RO	N/A	N/A	666F	6E6F	1	Y
AXIS#.SAFE.SOS_x.INTERNALSTATE	RO	N/A	N/A	N/A	N/A	N/A	N
AXIS#.SAFE.SS1_#.ACTIVE	RO	N/A	N/A	665F	6E5F	Inst1: 1 Inst2: 2 Inst3: 3	Y
AXIS#.SAFE.SS1_#.DEC	RW	div	Drive	N/A	N/A	N/A	N
AXIS#.SAFE.SS1_#.INTERNALSTATE	RO	N/A	N/A	N/A	N/A	N/A	N
AXIS#.SAFE.SS1_#.MODE	RW	0	Drive	N/A	N/A	N/A	N
AXIS#.SAFE.SS2_#.ACTIVE	RO	N/A	N/A	665F	6E5F	Inst1: 1 Inst2: 2	Y
AXIS#.SAFE.SS2_#.DEC	RW	div	Drive	N/A	N/A	N/A	N
AXIS#.SAFE.SS2_#.INTERNALSTATE	RO	N/A	N/A	N/A	N/A	N/A	N
AXIS#.SAFE.SS2_#.MODE	RW	0	Drive	N/A	N/A	N/A	N
AXIS#.SAFE.SSM_#.INRANGE	RO	N/A	N/A	66E0	6EE0	Inst1: 1 Inst2: 2	Y
AXIS#.SAFE.SSM_#.INTERNALSTATE	RO	N/A	N/A	N/A	N/A	N/A	N
AXIS#.SAFE.SSR_#.ACTIVE	RO	N/A	N/A	6680	6E80	Inst1: 1 Inst2: 2 Inst3: 3	Y
AXIS#.SAFE.SSR_#.INTERNALSTATE	RO	N/A	N/A	N/A	N/A	N/A	N
AXIS#.SAFE.STO.ACTIVE	RO	N/A	N/A	6640	6E40	0	Y
AXIS#.SAFE.STO.REPORTFAULT	RW	1	Drive	5007	5007	1	N
AXIS#.SAFE.TEMPWARNING.ACTIVE	RO	N/A	N/A	N/A	N/A	N/A	N
AXIS#.SAFE.VELOCITY	RO	N/A	N/A	6613	6E13	0	Y
AXIS#.SAFEPARAM.ABSOLUTEPOSEN	RW	0	Safety	3150	3250	4	N
AXIS#.SAFEPARAM.ABSOLUTEPOSRANGE	RW	0	Safety	3150	3250	6	N

Parameters related to safety functions	Acc.	Default	Parameter Package	CAN over EtherCAT			FSoE Object
				Axis1 Index 0x....	Axis2 Index 0x....	Sub	
AXIS#.SAFEPARAM.ABSOLUTEPOSRESETSOURCE	RW	0	Safety	3150	3250	5	N
AXIS#.SAFEPARAM.ABSOLUTEPOSRESETVALUE	RW	0	Safety	3150	3250	7	N
AXIS#.SAFEPARAM.ACCCOMPUTATIONINTERVAL	RW	1	Safety	3150	3250	3	N
AXIS1.SAFEPARAM.AXISCFGEN	RO	1	Safety	3100	-	2	N
AXIS2.SAFEPARAM.AXISCFGEN	RO	1	Safety	-	3100	3	N
AXIS#.SAFEPARAM.ENCODERSOURCE	RW	0	Safety	3150	3250	1	N
AXIS#.SAFEPARAM.SAR_#.ACCLOWERLIMIT	RW	1 Acc user unit	Safety	Inst1: 3166 Inst2: 3167 Inst3: 3168	Inst1: 3266 Inst2: 3267 Inst3: 3268	5	N
AXIS#.SAFEPARAM.SAR_#.ACCUPPERLIMIT	RW	1 Acc user unit	Safety	Inst1: 3166 Inst2: 3167 Inst3: 3168	Inst1: 3266 Inst2: 3267 Inst3: 3268	4	N
AXIS#.SAFEPARAM.SAR_#.FAULTREACTION	RW	1	Safety	Inst1: 3166 Inst2: 3167 Inst3: 3168	Inst1: 3266 Inst2: 3267 Inst3: 3268	6	N
AXIS#.SAFEPARAM.SAR_#.FSOE	RW	0	Safety	Inst1: 3166 Inst2: 3167 Inst3: 3168	Inst1: 3266 Inst2: 3267 Inst3: 3268	3	N
AXIS#.SAFEPARAM.SAR_#.FUNCTIONACTIVATION	RW	0	Safety	Inst1: 3166 Inst2: 3167 Inst3: 3168	Inst1: 3266 Inst2: 3267 Inst3: 3268	1	N
AXIS#.SAFEPARAM.SAR_#.SAFEINPUT	RW	0	Safety	Inst1: 3166 Inst2: 3167 Inst3: 3168	Inst1: 3266 Inst2: 3267 Inst3: 3268	2	N
AXIS#.SAFEPARAM.SBC.BRAKETIMEDELAY	RW	100ms	Safety	3156	3256	3	N
AXIS1.SAFEPARAM.SBC.BRAKE1ATTACHED	RW	see keyword chapter	Safety	3156	-	4	N
AXIS1.SAFEPARAM.SBC.BRAKE2ATTACHED	RW	see keyword chapter	Safety	3156	-	5	N
AXIS2.SAFEPARAM.SBC.BRAKE1ATTACHED	RW	see keyword chapter	Safety	-	3256	4	N

Parameters related to safety functions	Acc.	Default	Parameter Package	CAN over EtherCAT			FSoE Object
				Axis1 Index 0x....	Axis2 Index 0x....	Sub	
AXIS2.SAFEPARAM.SBC.BRAKE2ATTACHED	RW	see keyword chapter	Safety	-	3256	5	N
AXIS#.SAFEPARAM.SBC.MUTINGSOURCE	RW	0	Safety	3156	3256	4	N
AXIS#.SAFEPARAM.SBT.FUNCTIONACTIVATION	RW	1	Safety	3157	3257	1	N
AXIS#.SAFEPARAM.SBT.MAXAPPLLOAD	RW	1000mA	Safety	3157	3257	3	N
AXIS1.SAFEPARAM.SBT.MAXMOTIONBRAKE1	RW	300arcmin	Safety	3157	-	4	N
AXIS1.SAFEPARAM.SBT.MAXMOTIONBRAKE2	RW	300arcmin	Safety	3157	-	5	N
AXIS2.SAFEPARAM.SBT.MAXMOTIONBRAKE1	RW	300arcmin	Safety	-	3257	4	N
AXIS2.SAFEPARAM.SBT.MAXMOTIONBRAKE2	RW	300arcmin	Safety	-	3257	5	N
AXIS#.SAFEPARAM.SBT.MAXTIMEINTERVAL	RW	480min	Safety	3157	3257	2	N
AXIS#.SAFEPARAM.SBT.TORQUEDURATION	RW	500ms	Safety	3157	3257	6	N
AXIS#.SAFEPARAM.SCA.FUNCTIONACTIVATION	RW	0	Safety	Inst1: 316F Inst2: 3170 Inst3: 3171	Inst1: 326F Inst2: 3270 Inst3: 3271	1	N
AXIS#.SAFEPARAM.SCA.POSLOWERLIMIT	RW	0 Pos Unit	Safety	Inst1: 316F Inst2: 3170 Inst3: 3171	Inst1: 326F Inst2: 3270 Inst3: 3271	3	N
AXIS#.SAFEPARAM.SCA.POSUPPERLIMIT	RW	0 Pos Unit	Safety	Inst1: 316F Inst2: 3170 Inst3: 3171	Inst1: 326F Inst2: 3270 Inst3: 3271	2	N
AXIS#.SAFEPARAM.SDB.DELAYBEFORESWITCHING	RW	1ms	Safety	3158	3258	3	N
AXIS#.SAFEPARAM.SDB.FUNCTIONACTIVATION	RW	0	Safety	3158	3258	1	N
AXIS#.SAFEPARAM.SDB.READBACKSOURCE	RW	0	Safety	3158	3258	3	N
AXIS#.SAFEPARAM.SDI.FAULTREACTION	RW	1	Safety	3164	3264	10	N
AXIS#.SAFEPARAM.SDI.FUNCTIONACTIVATION	RW	0	Safety	3164	3264	1	N
AXIS#.SAFEPARAM.SDI.POSZEROWINDOW	RW	1 Pos Unit	Safety	3164	3264	8	N
AXIS#.SAFEPARAM.SDI.VELZEROWINDOW	RW	1 Vel Unit	Safety	3164	3264	9	N
AXIS#.SAFEPARAM.SDI.n.FSOE	RW	0	Safety	3164	3264	5	N
AXIS#.SAFEPARAM.SDI.n.SAFEINPUT	RW	0	Safety	3164	3264	3	N
AXIS#.SAFEPARAM.SDI.n.TIMEDELAYMONITORING	RW	1ms	Safety	3164	3264	7	N
AXIS#.SAFEPARAM.SDI.p.FSOE	RW	0	Safety	3164	3264	4	N
AXIS#.SAFEPARAM.SDI.p.SAFEINPUT	RW	0	Safety	3164	3264	2	N
AXIS#.SAFEPARAM.SDI.p.TIMEDELAYMONITORING	RW	1ms	Safety	3164	3264	6	N
AXIS#.SAFEPARAM.SLA_#.ACCLIMIT	RW	1 Acc Unit	Safety	3165	3265	4	N
AXIS#.SAFEPARAM.SLA_#.FAULTREACTION	RW	1	Safety	3165	3265	5	N
AXIS#.SAFEPARAM.SLA_#.FSOE	RW	0	Safety	3165	3265	3	N
AXIS#.SAFEPARAM.SLA_#.FUNCTIONACTIVATION	RW	0	Safety	3165	3265	1	N

Parameters related to safety functions	Acc.	Default	Parameter Package	CAN over EtherCAT			FSoE Object
				Axis1 Index 0x....	Axis2 Index 0x....	Sub	
AXIS#.SAFEPARAM.SLA_#.SAFEINPUT	RW	0	Safety	3165	3265	2	N
AXIS#.SAFEPARAM.SLI_#.FAULTREACTION	RW	1	Safety	Inst1: 3169 Inst2: 316A Inst3: 316B	Inst1: 3269 Inst2: 326A Inst3: 326B	7	N
AXIS#.SAFEPARAM.SLI_#.FSOE	RW	0	Safety	Inst1: 3169 Inst2: 316A Inst3: 316B	Inst1: 3269 Inst2: 326A Inst3: 326B	3	N
AXIS#.SAFEPARAM.SLI_#.FUNCTIONACTIVATION	RW	0	Safety	Inst1: 3169 Inst2: 316A Inst3: 316B	Inst1: 3269 Inst2: 326A Inst3: 326B	1	N
AXIS#.SAFEPARAM.SLI_#.POSRELOWERLIMIT	RW	1 Pos Unit	Safety	Inst1: 3169 Inst2: 316A Inst3: 316B	Inst1: 3269 Inst2: 326A Inst3: 326B	6	N
AXIS#.SAFEPARAM.SLI_#.POSRELUPPERLIMIT	RW	1 Pos Unit	Safety	Inst1: 3169 Inst2: 316A Inst3: 316B	Inst1: 3269 Inst2: 326A Inst3: 326B	5	N
AXIS#.SAFEPARAM.SLI_#.SAFEINPUT	RW	0	Safety	Inst1: 3169 Inst2: 316A Inst3: 316B	Inst1: 3269 Inst2: 326A Inst3: 326B	2	N
AXIS#.SAFEPARAM.SLI_#.TIMEDELAYMONITOR	RW	0ms	Safety	Inst1: 3169 Inst2: 316A Inst3: 316B	Inst1: 3269 Inst2: 326A Inst3: 326B	4	N
AXIS#.SAFEPARAM.SLP_#.FAULTREACTION	RW	1	Safety	Inst1: 316C Inst2: 316D Inst3: 316E	Inst1: 326C Inst2: 326D Inst3: 326E	7	N

Parameters related to safety functions	Acc.	Default	Parameter Package	CAN over EtherCAT			FSoE Object
				Axis1 Index 0x....	Axis2 Index 0x....	Sub	
<u>AXIS#.SAFEPARAM.SLP_#.FSOE</u>	RW	0	Safety	Inst1: 316C Inst2: 316D Inst3: 316E	Inst1: 326C Inst2: 326D Inst3: 326E	3	N
<u>AXIS#.SAFEPARAM.SLP_#.FUNCTIONACTIVATION</u>	RW	0	Safety	Inst1: 316C Inst2: 316D Inst3: 316E	Inst1: 326C Inst2: 326D Inst3: 326E	1	N
<u>AXIS#.SAFEPARAM.SLP_#.POSLOWERLIMIT</u>	RW	1 Pos Unit	Safety	Inst1: 316C Inst2: 316D Inst3: 316E	Inst1: 326C Inst2: 326D Inst3: 326E	5	N
<u>AXIS#.SAFEPARAM.SLP_#.POSUPPERLIMIT</u>	RW	1 Pos Unit	Safety	Inst1: 316C Inst2: 316D Inst3: 316E	Inst1: 326C Inst2: 326D Inst3: 326E	4	N
<u>AXIS#.SAFEPARAM.SLP_#.SAFEINPUT</u>	RW	0	Safety	Inst1: 316C Inst2: 316D Inst3: 316E	Inst1: 326C Inst2: 326D Inst3: 326E	2	N
<u>AXIS#.SAFEPARAM.SLP_#.TIMEDELAYMONITORING</u>	RW	0ms	Safety	Inst1: 316C Inst2: 316D Inst3: 316E	Inst1: 326C Inst2: 326D Inst3: 326E	6	N
<u>AXIS#.SAFEPARAM.SLS_#.DECLIMIT</u>	RW	0 Acc Unit	Safety	Inst1: 315C Inst2: 315D Inst3: 315E	Inst1: 325C Inst2: 325D Inst3: 325E	9	N
<u>AXIS#.SAFEPARAM.SLS_#.DECMONITOREN</u>	RW	0	Safety	Inst1: 315C Inst2: 315D Inst3: 315E	Inst1: 325C Inst2: 325D Inst3: 325E	8	N
<u>AXIS#.SAFEPARAM.SLS_#.FAULTREACTION</u>	RW	1	Safety	Inst1: 315C Inst2: 315D Inst3: 315E	Inst1: 325C Inst2: 325D Inst3: 325E	10	N

Parameters related to safety functions	Acc.	Default	Parameter Package	CAN over EtherCAT			FSOE Object
				Axis1 Index 0x....	Axis2 Index 0x....	Sub	
<u>AXIS#.SAFEPARAM.SLS_#.FSOE</u>	RW	0	Safety	Inst1: 315C Inst2: 315D Inst3: 315E	Inst1: 325C Inst2: 325D Inst3: 325E	3	N
<u>AXIS#.SAFEPARAM.SLS_#.FUNCTIONACTIVATION</u>	RW	0	Safety	Inst1: 315C Inst2: 315D Inst3: 315E	Inst1: 325C Inst2: 325D Inst3: 325E	1	N
<u>AXIS#.SAFEPARAM.SLS_#.SAFEINPUT</u>	RW	0	Safety	Inst1: 315C Inst2: 315D Inst3: 315E	Inst1: 325C Inst2: 325D Inst3: 325E	2	N
<u>AXIS#.SAFEPARAM.SLS_#.TIMEDELAYDECMONITORING</u>	RW	1ms	Safety	Inst1: 315C Inst2: 315D Inst3: 315E	Inst1: 325C Inst2: 325D Inst3: 325E	5	N
<u>AXIS#.SAFEPARAM.SLS_#.TIMEFORVELINLIMITS</u>	RW	1ms	Safety	Inst1: 315C Inst2: 315D Inst3: 315E	Inst1: 325C Inst2: 325D Inst3: 325E	6	N
<u>AXIS#.SAFEPARAM.SLS_#.TIMETOVELMONITORING</u>	RW	2ms	Safety	Inst1: 315C Inst2: 315D Inst3: 315E	Inst1: 325C Inst2: 325D Inst3: 325E	4	N
<u>AXIS#.SAFEPARAM.SLS_#.VELLIMIT</u>	RW	1 Vel Unit	Safety	Inst1: 315C Inst2: 315D Inst3: 315E	Inst1: 325C Inst2: 325D Inst3: 325E	7	N
<u>AXIS#.SAFEPARAM.SOS_x.FSOE</u>	RW	0	Safety	315B	325B	3	N
<u>AXIS#.SAFEPARAM.SOS_x.FUNCTIONACTIVATION</u>	RW	0	Safety	315B	325B	1	N
<u>AXIS#.SAFEPARAM.SOS_x.POSZEROWINDOW</u>	RW	1 Pos Unit	Safety	315B	325B	7	N
<u>AXIS#.SAFEPARAM.SOS_x.RESTARTACKBEHAVIOR</u>	RW	0	Safety	315B	325B	8	N
<u>AXIS#.SAFEPARAM.SOS_x.RESTARTACKSOURCE</u>	RW	0	Safety	315B	325B	9	N
<u>AXIS#.SAFEPARAM.SOS_x.SAFEINPUT</u>	RW	0	Safety	315B	325B	2	N
<u>AXIS#.SAFEPARAM.SOS_x.TIMEDELAYMONITORING</u>	RW	1ms	Safety	315B	325B	4	N
<u>AXIS#.SAFEPARAM.SOS_x.VELMONITOREN</u>	RW	0	Safety	315B	325B	6	N
<u>AXIS#.SAFEPARAM.SOS_x.VELZEROWINDOW</u>	RW	0 Vel Unit	Safety	315B	325B	5	N
<u>AXIS#.SAFEPARAM.SPEEDCOMPUTATIONINTERVAL</u>	RW	1ms	Safety	3150	3250	2	N

Parameters related to safety functions	Acc.	Default	Parameter Package	CAN over EtherCAT			FSoE Object
				Axis1 Index 0x....	Axis2 Index 0x....	Sub	
<u>AXIS#.SAFEPARAM.SS1_#.DECLIMIT</u>	RW	0 Dec Unit	Safety	Inst1: 3153 Inst2: 3154 Inst3: 3155	Inst1: 3253 Inst2: 3254 Inst3: 3255	9	N
<u>AXIS#.SAFEPARAM.SS1_#.FSOE</u>	RW	0	Safety	Inst1: 3153 Inst2: 3154 Inst3: 3155	Inst1: 3253 Inst2: 3254 Inst3: 3255	3	N
<u>AXIS#.SAFEPARAM.SS1_#.FUNCTIONACTIVATION</u>	RW	Inst1: 1 Inst2: 0 Inst3: 0	Safety	Inst1: 3153 Inst2: 3154 Inst3: 3155	Inst1: 3253 Inst2: 3254 Inst3: 3255	1	N
<u>AXISx.SAFEPARAM.SS1_#.SAFEINPUT</u>	RW	0	Safety	Inst1: 3153 Inst2: 3154 Inst3: 3155	Inst1: 3253 Inst2: 3254 Inst3: 3255	2	N
<u>AXIS#.SAFEPARAM.SS1_#.TIMEDELAYDEC MONITORING</u>	RW	1ms	Safety	Inst1: 3153 Inst2: 3154 Inst3: 3155	Inst1: 3253 Inst2: 3254 Inst3: 3255	5	N
<u>AXIS#.SAFEPARAM.SS1_#.TIMEFORVELZERO</u>	RW	1ms	Safety	Inst1: 3153 Inst2: 3154 Inst3: 3155	Inst1: 3253 Inst2: 3254 Inst3: 3255	6	N
<u>AXIS#.SAFEPARAM.SS1_#.TIMETOSTO</u>	RW	2ms	Safety	Inst1: 3153 Inst2: 3154 Inst3: 3155	Inst1: 3253 Inst2: 3254 Inst3: 3255	4	N
<u>AXIS#.SAFEPARAM.SS1_#.VELDECMONITOREN</u>	RW	0	Safety	Inst1: 3153 Inst2: 3154 Inst3: 3155	Inst1: 3253 Inst2: 3254 Inst3: 3255	7	N
<u>AXIS#.SAFEPARAM.SS1_#.VELZEROWINDOW</u>	RW	1 Vel Unit	Safety	Inst1: 3153 Inst2: 3154 Inst3: 3155	Inst1: 3253 Inst2: 3254 Inst3: 3255	8	N

Parameters related to safety functions	Acc.	Default	Parameter Package	CAN over EtherCAT			FSoE Object
				Axis1 Index 0x....	Axis2 Index 0x....	Sub	
<u>AXIS#.SAFEPARAM.SS2_#.DECLIMIT</u>	RW	0 Dec Unit	Safety	Inst1: 3159 Inst2: 315A	Inst1: 3259 Inst2: 325A	8	N
<u>AXIS#.SAFEPARAM.SS2_#.DECMONITOREN</u>	RW	0	Safety	Inst1: 3159 Inst2: 315A	Inst1: 3259 Inst2: 325A	7	N
<u>AXIS#.SAFEPARAM.SS2_#.FAULTREACTION</u>	RW	1	Safety	Inst1: 3159 Inst2: 315A	Inst1: 3259 Inst2: 325A	9	N
<u>AXIS#.SAFEPARAM.SS2_#.FSOE</u>	RW	0	Safety	Inst1: 3159 Inst2: 315A	Inst1: 3259 Inst2: 325A	3	N
<u>AXIS#.SAFEPARAM.SS2_#.FUNCTIONACTIVATION</u>	RW	0	Safety	Inst1: 3159 Inst2: 315A	Inst1: 3259 Inst2: 325A	1	N
<u>AXIS#.SAFEPARAM.SS2_#.SAFEINPUT</u>	RW	0	Safety	Inst1: 3159 Inst2: 315A	Inst1: 3259 Inst2: 325A	2	N
<u>AXIS#.SAFEPARAM.SS2_#.TIMEDELAYDECMONITORING</u>	RW	1ms	Safety	Inst1: 3159 Inst2: 315A	Inst1: 3259 Inst2: 325A	4	N
<u>AXIS#.SAFEPARAM.SS2_#.TIMEFORVELZERO</u>	RW	1ms	Safety	Inst1: 3159 Inst2: 315A	Inst1: 3259 Inst2: 325A	6	N
<u>AXIS#.SAFEPARAM.SS2_#.TIMETOSOS</u>	RW	2ms	Safety	Inst1: 3159 Inst2: 315A	Inst1: 3259 Inst2: 325A	5	N
<u>AXIS#.SAFEPARAM.SSM_#.FUNCTIONACTIVATION</u>	RW	0	Safety	Inst1: 315F Inst2: 3160	Inst1: 325F Inst2: 3260	1	N
<u>AXIS#.SAFEPARAM.SSM_#.VELLOWERLIMIT</u>	RW	0 Vel Unit	Safety	Inst1: 315F Inst2: 3160	Inst1: 325F Inst2: 3260	2	N
<u>AXIS#.SAFEPARAM.SSM_#.VELUPPERLIMIT</u>	RW	0 Vel Unit	Safety	Inst1: 315F Inst2: 3160	Inst1: 325F Inst2: 3260	3	N

Parameters related to safety functions	Acc.	Default	Parameter Package	CAN over EtherCAT			FSoE Object
				Axis1 Index 0x....	Axis2 Index 0x....	Sub	
<u>AXIS#.SAFEPARAM.SSR_#.DECLIMIT</u>	RW	0 Dec Unit	Safety	Inst1: 315F Inst2: 3160 Inst3: 3163	Inst1: 325F Inst2: 3260 Inst3: 3263	5	N
<u>AXIS#.SAFEPARAM.SSR_#.DECMONITOREN</u>	RW	0	Safety	Inst1: 315F Inst2: 3160 Inst3: 3163	Inst1: 325F Inst2: 3260 Inst3: 3263	6	N
<u>AXIS#.SAFEPARAM.SSR_#.FAULTREACTION</u>	RW	1	Safety	Inst1: 315F Inst2: 3160 Inst3: 3163	Inst1: 325F Inst2: 3260 Inst3: 3263	11	N
<u>AXIS#.SAFEPARAM.SSR_#.FSOE</u>	RW	0	Safety	Inst1: 315F Inst2: 3160 Inst3: 3163	Inst1: 325F Inst2: 3260 Inst3: 3263	3	N
<u>AXIS#.SAFEPARAM.SSR_#.FUNCTIONACTIVATION</u>	RW	0	Safety	Inst1: 315F Inst2: 3160 Inst3: 3163	Inst1: 325F Inst2: 3260 Inst3: 3263	1	N
<u>AXIS#.SAFEPARAM.SSR_#.SAFEINPUT</u>	RW	0	Safety	Inst1: 315F Inst2: 3160 Inst3: 3163	Inst1: 325F Inst2: 3260 Inst3: 3263	2	N
<u>AXIS#.SAFEPARAM.SSR_#.TIMEDELAYDEC MONITORING</u>	RW	1ms	Safety	Inst1: 315F Inst2: 3160 Inst3: 3163	Inst1: 325F Inst2: 3260 Inst3: 3263	7	N
<u>AXIS#.SAFEPARAM.SSR_#.TIMEFORVELINLIMITS</u>	RW	1ms	Safety	Inst1: 315F Inst2: 3160 Inst3: 3163	Inst1: 325F Inst2: 3260 Inst3: 3263	8	N
<u>AXIS#.SAFEPARAM.SSR_#.TIMETOVELMONITORING</u>	RW	1ms	Safety	Inst1: 315F Inst2: 3160 Inst3: 3163	Inst1: 325F Inst2: 3260 Inst3: 3263	4	N

Parameters related to safety functions	Acc.	Default	Parameter Package	CAN over EtherCAT			FSoE Object
				Axis1 Index 0x....	Axis2 Index 0x....	Sub	
AXIS#.SAFEPARAM.SSR.#.VELLOWERLIMIT	RW	0 Vel Unit	Safety	Inst1: 315F Inst2: 3160 Inst3: 3163	Inst1: 325F Inst2: 3260 Inst3: 3263	9	N
AXIS#.SAFEPARAM.SSR.#.VELUPPERLIMIT	RW	0 Vel Unit	Safety	Inst1: 315F Inst2: 3160 Inst3: 3163	Inst1: 325F Inst2: 3260 Inst3: 3263	10	N
AXIS#.SAFEPARAM.STO.FSOE	RW	see keyword chapter	Safety	3152	3252	3	N
AXIS#.SAFEPARAM.STO.FUNCTIONACTIVATION	RW	1	Safety	3152	3252	1	N
AXIS#.SAFEPARAM.STO.RESTARTACKMODE	RW	0	Safety	3152	3252	4	N
AXIS#.SAFEPARAM.STO.RESTARTACKSOURCE	RW	0	Safety	3152	3252	5	N
AXIS1.SAFEPARAM.STO.SAFEINPUT	RW	see keyword chapter	Safety	3152	-	2	N
AXIS2.SAFEPARAM.STO.SAFEINPUT	RW	see keyword chapter	Safety	-	3252	2	N
AXIS#.SAFEPARAM.UNIT.ACCTFACTOR	RW	None	Safety	3151	3251	11	N
AXIS#.SAFEPARAM.UNIT.ACCINENC	RW	1	Safety	3152	3252	10	N
AXIS#.SAFEPARAM.UNIT.ACCINUSER	RW	60	Safety	3152	3252	9	N
AXIS#.SAFEPARAM.UNIT.ACCLABEL	RW	rpm/s	Safety	3152	3252	12	N
AXIS#.SAFEPARAM.UNIT.POSFACTOR	RW	deci	Safety	3152	3252	3	N
AXIS#.SAFEPARAM.UNIT.POSINENC	RW	1	Safety	3152	3252	2	N
AXIS#.SAFEPARAM.UNIT.POSINUSER	RW	3600	Safety	3152	3252	1	N
AXIS#.SAFEPARAM.UNIT.POSLABEL	RW	Degree	Safety	3152	3252	4	N
AXIS#.SAFEPARAM.UNIT.VELFACTOR	RW	None	Safety	3152	3252	7	N
AXIS#.SAFEPARAM.UNIT.VELINENC	RW	1	Safety	3152	3252	6	N
AXIS#.SAFEPARAM.UNIT.VELINUSER	RW	60	Safety	3152	3252	5	N
AXIS#.SAFEPARAM.UNIT.VELLABEL	RW	rpm	Safety	3152	3252	8	N
BRAKE1.SAFE.SBT.ELAPSED	RO	N/A	N/A	40F2	40F2	1	N
BRAKE2.SAFE.SBT.ELAPSED	RO	N/A	N/A	40F2	40F2	2	N
BRAKE1.SAFE.SBT.STATE	RO	N/A	N/A	40F3	40F3	1	N
BRAKE2.SAFE.SBT.STATE	RO	N/A	N/A	40F3	40F3	2	N
SAFE.CFGERROR	RO	N/A	N/A	N/A	N/A	N/A	N
SAFE.CHANGEPASSWORD	WO	N/A	N/A	N/A	N/A	N/A	N
SAFE.CLEARSAFEID	WO	N/A	N/A	N/A	N/A	N/A	N
SAFE.CRC	RO	N/A	N/A	37C3	37C3	0	N
SAFE.DEVICECRC	RO	N/A	N/A	N/A	N/A	N/A	N
SAFE.ERROR	RO	N/A	N/A	37C4	37C4	0	N

Parameters related to safety functions	Acc.	Default	Parameter Package	CAN over EtherCAT			FSoE Object
				Axis1 Index 0x....	Axis2 Index 0x....	Sub	
SAFE.ERRORINSTANCE	RO	N/A	N/A	N/A	N/A	N/A	N
SAFE.ID	RO	N/A	N/A	N/A	N/A	N/A	N
SAFE.IDANDCRC	RO	N/A	N/A	N/A	N/A	N/A	N
SAFE.INVALIDATEPARAMS	WO	N/A	N/A	N/A	N/A	N/A	N
SAFE.MONITOR#.AXIS	RW	0	N/A	N/A	N/A	N/A	N
SAFE.MONITOR#.DATA	RO	N/A	N/A	N/A	N/A	N/A	N
SAFE.MONITOR#.INSTANCE	RW	0	N/A	N/A	N/A	N/A	N
SAFE.MONITOR#.SOURCE	RW	0	N/A	N/A	N/A	N/A	N
SAFE.STATE	RO	N/A	N/A	37C1	37C1	0	N
SAFE.SWITCH	RO	N/A	N/A	37C2	37C2	0	N
SAFE.VALIDATEPARAM	WO	N/A	N/A	37C0	37C0	1,2,3,4	N
SAFE.VALIDATIONLOG	RO	N/A	N/A	N/A	N/A	N/A	N
SAFE.VERIFYFW	WO	N/A	N/A	N/A	N/A	N/A	N
SAFEPARAM.ENCODERHDSLTYPE1	RW	0	Safety	3103	3103	1	N
SAFEPARAM.ENCODERHDSLTYPE2	RW	0	Safety	3103	3103	3	N
SAFEPARAM.HDSLCHAN1SINGLETURNRES1	RW	0	Safety	3103	3103	2	N
SAFEPARAM.HDSLCHAN1SINGLETURNRES2	RW	0	Safety	3103	3103	4	N
SAFEPARAM.IOFAILUREACKSOURCE	RW	0	Safety	3100	3100	1	N
SAFEPARAM.SAFEFIELDBUS.ACTIVATION	RW	see keyword chapter	Safety	N/A	N/A	N/A	N
SAFEPARAM.SIN.DISTINCTPULSE	RW	0	Safety	3101	3101	1	N
SAFEPARAM.SINDUAL#.EN	RW	see keyword chapter	Safety	3101	3101	Inst1: 2 Inst2: 3	N
SAFEPARAM.SOUTDUAL#.EN	RW	0	Safety	3102	3102	Inst1: 1 Inst2: 2	N
SAFEPARAM.SOUTDUAL#.SOURCE	RW	0	Safety	3102	3102	Inst1: 3 Inst2: 4	N
SAFEPARAM.SOUT#.SOURCE	RW	see keyword chapter	Safety	3102	3102	Inst1: 5 Inst2: 6 Inst3: 7 Inst4: 8	N
SINDUAL#.STATE	RO	N/A	N/A	N/A	N/A	N/A	N
SIN#.STATE	RO	N/A	N/A	N/A	N/A	N/A	N
SOUTDUAL#.STATE	RO	N/A	N/A	N/A	N/A	N/A	N
SOUT#.STATE	RO	N/A	N/A	N/A	N/A	N/A	N

9.9.1 Safety Parameters, sorted alphanumeric

9.9.1.1 AXIS#.SAFE.ABSOLUTEPOSITION

Description

Returns the safe absolute position. This only returns a valid value when a safe encoder is attached to the considered axis, and the safe absolute position support is enabled in the safety parameters ([AXIS#.SAFEPARAM.ABSOLUTEPOSEN](#)) and the absolute position is valid ([AXIS#.SAFE.ABSOLUTEPOSVALID](#)).

If the absolute position is not valid, a safe homing is required.

Versions

Action	Version	Notes
Implemented	02-04-00-000	Implemented in SMM revision v0.56

General Information

Type	Read Only
Units	N/A
Range	$[-2^{31}+1, 2^{31}-1]$
Default Value	N/A
Data Type	Integer
Stored in Non-Volatile Memory	No

9.9.1.2 AXIS#.SAFE.ABSOLUTEPOSVALID

Description

Indicates if the absolute position retrieved from the safe encoder by the safety system is valid or not. It is dependent on whether the read position matches the position stored by the safety system. If it is not valid, a safe homing is required.

Value	Description
0	Not valid
1	Valid

Context

For safe encoder details refer to "Motor feedback requirements" (→ # 216).

Versions

Action	Version	Notes
Implemented	2-04-00-000	Implemented in SMM revision v0.56

General Information

Type	Read Only
Units	N/A
Range	0, 1
Default Value	0 (Not valid)
Data Type	Integer
Stored in Non-Volatile Memory	No

9.9.1.3 AXIS#.SAFE.ACCELERATION

Description

Returns the safe acceleration. This only returns a valid value when a safe encoder is attached to the considered axis.

Versions

Action	Version	Notes
Implemented	02-04-00-000	Implemented in SMM revision v0.56

General Information

Type	Read Only
Units	N/A
Range	$[-2^{31}+1, 2^{31}-1]$
Default Value	N/A
Data Type	Integer
Stored in Non-Volatile Memory	No

9.9.1.4 AXIS#.SAFE.BRAKE#.STATE

Description

Indicates the internal state of the brake state machine.

Value	Description
0	Brake engaged
1	Releasing brake
2	Brake released
3	Engaging brake

Context

For complete SBC information refer to "SBC (Safe Brake Control)" (→ # 240).

Versions

Action	Version	Notes
Implemented	02-00-00-000	

General Information

Type	Read Only
Units	N/A
Range	0 or 4
Default Value	0
Data Type	Integer
Stored in Non-Volatile Memory	No

9.9.1.5 AXIS#.SAFE.ERROR.ACTIVE

Description

Indicates whether the safety system is in error or not. "SAFE.ERROR" (→ # 514) and "SAFE.ERRORINSTANCE" (→ # 516) can be used to retrieve information about the error.

Value	Description
0	No error
1	Error

Versions

Action	Version	Notes
Implemented	02-04-00-000	Implemented in SMM revision v0.56

General Information

Type	Read Only
Units	N/A
Range	0, 1
Default Value	N/A
Data Type	Integer
Stored in Non-Volatile Memory	No

9.9.1.6 AXIS#.SAFE.FSOE.APPLPARAMLENGTH

Description

Indicates the size of the FSoE application parameters. If using WorkBench safety parameters, this is 0 and if using application parameters over FSoE it is 4 bytes.

Context

For complete FSoE information refer to the *AKD2G EtherCAT Manual*.

Versions

Action	Version	Notes
Implemented	02-01-02-000	

General Information

Type	Read Only
Units	N/A
Range	0-65535
Default Value	N/A
Data Type	Integer
Stored in Non-Volatile Memory	No

9.9.1.7 AXIS#.SAFE.FSOE.COMMPARAMLENGTH

Description

Indicates the length of FSoE communication parameters. This is fixed at 2 bytes because the only com parameter transferred is the watchdog time which is U16.

Context

For complete FSoE information refer to the *AKD2G EtherCAT Manual*.

Versions

Action	Version	Notes
Implemented	02-01-02-000	

General Information

Type	Read Only
Units	N/A
Range	2
Default Value	N/A
Data Type	Integer
Stored in Non-Volatile Memory	No

9.9.1.8 AXIS#.SAFE.FSOE.CONNECTIONID

Description

Indicates the current FSoE connection ID assigned by the FSoE master once the connection FSoE state is reached.

Context

For complete FSoE information refer to the *AKD2G EtherCAT Manual*.

Versions

Action	Version	Notes
Implemented	02-01-02-000	

General Information

Type	Read Only
Units	N/A
Range	1-65535
Default Value	N/A
Data Type	Integer
Stored in Non-Volatile Memory	No

9.9.1.9 AXIS#.SAFE.FSOE.CONNECTIONTYPE

Description

This returns the FSoE connection type parameter. In the case of the AKD2G, this value is a constant 2 to indicate a slave device.

Context

For complete FSoE information refer to the *AKD2G EtherCAT Manual*.

Versions

Action	Version	Notes
Implemented	02-01-02-000	

General Information

Type	Read Only
Units	N/A
Range	2
Default Value	N/A
Data Type	Integer
Stored in Non-Volatile Memory	No

9.9.1.10 AXIS#.SAFE.FSOE.LASTERROR

Description

This parameter gives the last error shown to the Fail Safe over EtherCAT (FSoE) stack with one of the following values:

Value	Description
0	Local reset or acknowledgement of a RESET command
1	Unexpected command
2	Unknown command
3	Invalid connection ID
4	CRC error
5	Watchdog has expired
6	Invalid FSoE slave address
7	Invalid safety data
8	Invalid communication parameter length
9	Invalid communication parameter data
10	Invalid application parameter length
11	Invalid application parameter data

Context

For complete FSoE information refer to the *AKD2G EtherCAT Manual*.

Versions

Action	Version	Notes
Implemented	02-01-02-000	Implemented in SMM v0.54

General Information

Type	Read Only
Units	N/A
Range	0, 0xFF
Default Value	N/A
Data Type	Integer
Stored in Non-Volatile Memory	No

9.9.1.11 AXIS#.SAFE.FSOE.PROTOCOLVERSION

Description

Displays the version of the FSoE protocol in use.

Context

For complete FSoE information refer to the *AKD2G EtherCAT Manual*.

Versions

Action	Version	Notes
Implemented	02-01-02-000	

General Information

Type	Read Only
Units	N/A
Range	0-65535
Default Value	N/A
Data Type	Integer
Stored in Non-Volatile Memory	No

9.9.1.12 AXIS#.SAFE.FSOE.SAFETYADDR

Description

This command is the FSoE safety address for this axis. The format of the safety address is nnaa where nn is the SafeID and aa is the axis ID.

Example

If SafeID is 10 then AXIS1.SAFE.FSOE.SAFETYADDR is 1001 and AXIS2.SAFE.FSOE.SAFETYADDR is 1002.

Context

For complete FSoE information refer to the *AKD2G EtherCAT Manual*.

Versions

Action	Version	Notes
Implemented	02-01-02-000	

General Information

Type	Read Only
Units	N/A
Range	101 to 9901 for Axis 1 102 to 9902 for Axis 2
Default Value	N/A
Data Type	Integer
Stored in Non-Volatile Memory	No

9.9.1.13 AXIS#.SAFE.FSOE.SRACRC

Description

Returns the Safety Related Application (SRA) Cyclic Redundancy Check (CRC) used to validate safety parameters through Fail Safe over EtherCAT (FSoE).

Versions

Action	Version	Notes
Implemented	02-04-00-000	Implemented in SMM revision v0.56

General Information

Type	Read Only
Units	N/A
Range	N/A
Default Value	N/A
Data Type	Integer
Stored in Non-Volatile Memory	No

9.9.1.14 AXIS#.SAFE.FSOE.STATE

Description

This is the EtherCAT FSoE command word being sent to the drive from the FSoE master.

Value	Description
0x36	ProcessData – Process data is passed between FSoE master and slave.
0x2A	Reset – FSoE communication is in reset state.
0x4E	Session – FSoE session is being established between master and slave.
0x64	Connection – FSoE connection is being established between master and slave.
0x52	Parameter – Safe parameters are being downloaded to slave.
0x08	FailSafeData – Fail-safe values are being used (usually due to an error).

Context

For complete FSoE information refer to the *AKD2G EtherCAT Manual*.

Versions

Action	Version	Notes
Implemented	02-01-02-000	

General Information

Type	Read Only
Units	N/A
Range	0x08, 0x2A, 0x36, 0x4E, 0x52, 0x64
Default Value	N/A
Data Type	Integer
Stored in Non-Volatile Memory	No

9.9.1.15 AXIS#.SAFE.FSOE.WATCHDOGTIME

Description

The current FSoE watchdog time in milliseconds. If an FSoE packet is not received within the configured time the drive enters a safe state. This is configured by using the FSoE master.

Context

For complete FSoE information refer to the *AKD2G EtherCAT Manual*.

Versions

Action	Version	Notes
Implemented	02-01-02-000	

General Information

Type	Read Only
Units	N/A
Range	7 to 65535
Default Value	100
Data Type	Integer
Stored in Non-Volatile Memory	No

9.9.1.16 AXIS#.SAFE.FUNCTIONGRAPH

This parameter returns the graph of the safety functions configured in the safety parameters.

The following format is used:

NODEID: Name(**NODENAME**); Type(**NODETYPE**); State(**NODESTATE**); FunctionSource(**LIST_OF_FUNCTION_SOURCE**); FaultReactionSource(**LIST_OF_FAULT_REACTION**); InputSource(**LIST_OF_INPUTSOURCE**); FSoESource(**LIST_OF_FSOE_SOURCE**); Properties(**LIST_OF_PROPERTIES**)

- **NODEID**: node unique ID, built as follows:
 - Safe functions: SOS, SS1_1, SLS_3, ...
 - Safe inputs: SIN1_SOS, SINDUAL2_SS1_2, ...
 - FSoE: FSOE_SOS, FSOE_SS1_1, ...
 - I/O Error: IOError
- **NODENAME**: function name to display (eg FSoE, SIN1, SS1_1, ...) [displayed in the block]
- **NODETYPE**: node type - SIN, SINDUAL, FSOE, FUNCTION, ERROR [type of graphical block]
- **NODESTATE** can be: [colorization of the block]
 - For FUNCTION: "Idle", "ProcessComplete", "Active", "Faulted"
 - For SIN, SINDUAL or FSoE: "On", "Off"
 - For ERROR: "Normal", "Error"
- **LIST_OF_FUNCTION_SOURCE**, **LIST_OF_FAULT_REACTION**, **LIST_OF_INPUTSOURCE** and **LIST_OF_FSOE_SOURCE** are a list of **NODEIDs** separated by a comma
- **LIST_OF_PROPERTIES**: string list to display separated by commas

Versions

Action	Version	Notes
Implemented	Next release	Implemented in SMM revision v0.54

General Information

Type	Info
Units	N/A
Range	N/A
Default Value	N/A
Data Type	N/A
Stored in Non-Volatile Memory	N/A

9.9.1.17 AXIS#.SAFE.FUNCTIONSTATUS

Description

This value returns a bit field which contains a status for some safety functions. The bit field is described in the following table:

Bit	Value	Contents
0	STO state	= 1 when STO is active
1	SSM state Instance 1	= 1 when SSM Instance 1 reports the speed in the given range
2	SSM state Instance 2	= 1 when SSM Instance 2 reports the speed in the given range
3	SOS Instance 1	= 1 when SOS is active
4	SSR Instance 1	= 1 while the speed is limited
5	SDIp status	= 1 when the motor is moving in positive direction
6	SDIn status	= 1 when the motor is moving in negative direction
7	Error active	= 1 when an error is active
8	SCA Instance 1	= 1 while the position is within the given limits
9	SCA Instance 2	= 1 while the position is within the given limits
10	SCA Instance 3	= 1 while the position is within the given limits
11	SLA state	= 1 while the limited acceleration is held
12	SAR Instance 3	= 1 while the acceleration is limited
13	SSR Instance 2	= 1 while the speed is limited
14	SSR Instance 3	= 1 while the speed is limited
15	Not used	Not used
16	SLS state Instance 1	= 1 while the limited speed is held
17	SLS state Instance 2	= 1 while the limited speed is held
18	SLS state Instance 3	= 1 while the limited speed is held
19	SS1 status Instance 1	= 1 while SS1 is active
20	SS1 status Instance 2	= 1 while SS1 is active
21	SS1 status Instance 3	= 1 while SS1 is active
22	SS2 status Instance 1	= 1 while SS2 is active
23	SS2 status Instance 2	= 1 while SS2 is active
24	SLI Instance 1	= 1 while the position is limited
25	SLI Instance 2	= 1 while the position is limited
26	SLI Instance 3	= 1 while the position is limited
27	SLP Instance 1	= 1 while the position is limited
28	SLP Instance 2	= 1 while the position is limited
29	SLP Instance 3	= 1 while the position is limited
30	SAR Instance 1	= 1 while the acceleration is limited
31	SAR Instance 2	= 1 while the acceleration is limited
32	SDIp active	= 1 when is not allowed to move in the positive direction
33	SDIn active	= 1 when is not allowed to move in the negative direction
34	SOS Instance 2	= 1 when SOS is active

Versions

Action	Version	Notes
Implemented	02-05-03-002	

General Information

Type	Read Only
Units	Bit field
Default Value	0
Data Type	U64
Stored in Non-Volatile Memory	No

9.9.1.18 AXIS#.SAFE.POSITION

Description

Returns the safe position. This only returns a valid value when a safe encoder is attached to the considered axis.

Versions

Action	Version	Notes
Implemented	02-04-00-000	Implemented in SMM revision v0.56

General Information

Type	Read Only
Units	N/A
Range	$[-2^{31}+1, 2^{31}-1]$
Default Value	N/A
Data Type	Integer
Stored in Non-Volatile Memory	No

9.9.1.19 AXIS#.SAFE.RESTARTACK.REQUESTED

Description

Indicates whether an acknowledge is requested by Safe Operating Stop (SOS) or Safe Torque Off (STO) to restart. When the acknowledge is requested, the parameter is 1, otherwise 0. Restart acknowledge is requested when:

- STO or SOS is configured to restart manually.
- The condition which activates STO or SOS is cleared.

Value	Description
0	No restart acknowledges requested
1	Restart acknowledge requested

Versions

Action	Version	Notes
Implemented	2-00-00-000	Implemented in SMM revision v0.56

General Information

Type	Read Only
Units	N/A
Range	0, 1
Default Value	N/A
Data Type	Integer
Stored in Non-Volatile Memory	No

9.9.1.20 AXIS#.SAFE.SAR_#.ACTIVE

Description

Indicates whether the Safe Acceleration Range (SAR) function instance is active.

Value	Description
0	Not active
1	Active

Context

For complete SAR information refer to "SAR (Safe Acceleration Range)" (→ # 276).

Versions

Action	Version	Notes
Implemented	2-04-00-000	Implemented in SMM revision v0.56

General Information

Type	Read Only
Units	N/A
Range	0, 1
Default Value	N/A
Data Type	Integer
Stored in Non-Volatile Memory	No

9.9.1.21 AXIS#.SAFE.SAR_#.INTERNALSTATE

Description

Indicates the internal state of the Safe Acceleration Range (SAR) function state machine.

Value	Description
0	Not Running
1	Monitoring
2	Fault Reaction

Context

For complete SAR information refer to "SAR (Safe Acceleration Range)" (→ # 276).

Versions

Action	Version	Notes
Implemented	2-04-00-000	Implemented in SMM revision v0.56

General Information

Type	Read Only
Units	N/A
Range	0, 1, 2, 3
Default Value	N/A
Data Type	Integer
Stored in Non-Volatile Memory	No

9.9.1.22 AXIS#.SAFE.SBC.ACTIVE

Description

Indicates whether Safe Brake Control (SBC) is active or not. When SBC is active the brake cannot be commanded to release. If SBC is enabled, it is executed once stopped during all stopping safety functions. Once the safety function condition clears, SBC will stop and allow the brake to be released.

Context

For complete SBC information refer to "SBC (Safe Brake Control)" (→ # 240).

Versions

Action	Version	Notes
Implemented	02-01-02-000	

General Information

Type	Read Only
Units	N/A
Range	0 or 1
Default Value	N/A
Data Type	Integer
Stored in Non-Volatile Memory	No

9.9.1.23 AXIS#.SAFE.SBT.ERROR

Description

Read the error of the Safe Brake Test (SBT) on the specified axis. The return value can be one of the following:

Value	Description
0	No error.
1	Fail to start the safe brake test. To start safe brake test, the axis must be enabled, the attached brakes must be released, and the axis must be at standstill.
2	Brakes are not released. To start safe brake test, the axis must be enabled, the attached brakes must be released, and the axis must be at standstill.
3	Fail to apply the brake. To find which brakes failed, see (→ # 508).
4	Fail to release the brake. To find which brakes failed, see (→ # 508).
5	Fail to apply current on the axis.
6	Motion limit exceed. Brake may be broken. To find which brakes failed, see (→ # 508).
7	Current feedback out of range. To find which brakes failed, see (→ # 508).
8	Communication error between the non-safe system part and the SMM.
9	Timeout. The safe brake test wasn't able to complete.
10	System error on the SMM.
11	Interrupted by user.
12	Measured load is bigger than the configured maximum load.
255	Unknown error.

Code

```
--> AXIS1.SAFE.SBT.ERROR
0
```

Context

For complete SBT information refer to "SBT (Safe Brake Test)" (→ # 249).

Versions

Action	Version	Notes
Implemented	02-00-00-000	Implemented in SMM revision v0.32

General Information

Type	Read Only
Units	N/A
Range	0 - 11
Default Value	N/A
Data Type	Integer
Stored in Non-Volatile Memory	No

9.9.1.24 AXIS#.SAFE.SBT.MOVE

Description

Executes Safe Brake Test (SBT) on the specified axis. All brakes attached to this axis are tested. A maximum of two brakes can be attached to a specific axis. For this command to work, Safe Brake Control (SBC) and SBT must be configured consistently in the SMM using safety parameters.

Code

```
--> AXIS1.SAFE.SBT.MOVE
```

Context

For complete information on SBT, refer to "SBT (Safe Brake Test)" (→ # 249).

Versions

Action	Version	Notes
Implemented	02-00-00-000	Implemented in SMM revision v0.32

General Information

Type	Command
Units	N/A
Range	N/A
Default Value	N/A
Data Type	N/A
Stored in Non-Volatile Memory	No

9.9.1.25 AXIS#.SAFE.SBT.SBA.ACTIVE

Description

Indicates the safe brake acknowledge state.

Value	Description
1	Brake state is safe
0	Brake needs an acknowledge

Context

For complete SBC/SBT information refer to "SBC (Safe Brake Control)" (→ # 240) / "SBT (Safe Brake Test)" (→ # 249).

Versions

Action	Version	Notes
Implemented	02-02-00-000	

General Information

Type	Read Only
Units	N/A
Range	0 or 1
Default Value	N/A
Data Type	Integer
Stored in Non-Volatile Memory	No

9.9.1.26 AXIS#.SAFE.SBT.STATE

Description

Reads the state of the Safe Brake Test (SBT) on the specified axis. The return value can be one of the following:

Value	Description
0	The test is not running.
1	The test is starting.
2	The test is started.
3	The brake is tested.
4	The test is stopping.

Code

```
--> AXIS1.SAFE.SBT.STATE
0
```

Context

For more information on "SBT (Safe Brake Test)" (→ # 249).

Versions

Action	Version	Notes
Implemented	2-00-00-000	Implemented in SMM revision v0.32

General Information

Type	Read Only
Units	N/A
Range	0...4
Default Value	N/A
Data Type	Integer
Stored in Non-Volatile Memory	No

9.9.1.27 AXIS#.SAFE.SCA_#.INRANGE

Description

Indicates whether the position is in range or not when using the Safe CAm (SCA) function.

Value	Description
0	Not in range
1	In range

Context

For complete SCA information refer to (→ # 355).

Versions

Action	Version	Notes
Implemented	2-04-00-000	Implemented in SMM revision v0.56

General Information

Type	Read Only
Units	N/A
Range	0, 1
Default Value	N/A
Data Type	Integer
Stored in Non-Volatile Memory	No

9.9.1.28 AXIS#.SAFE.SCA_#.INTERNALSTATE

Description

Indicates the internal state of the Safe CAm (SCA) function state machine.

Value	Description
0	Not in range
1	In range

Context

For complete SCA information refer to (→ # 356).

Versions

Action	Version	Notes
Implemented	2-04-00-000	Implemented in SMM revision v0.56

General Information

Type	Read Only
Units	N/A
Range	0, 1
Default Value	N/A
Data Type	Integer
Stored in Non-Volatile Memory	No

9.9.1.29 AXIS#.SAFE.SDIn.INTERNALSTATE

Description

Indicates the internal state of the Safe Direction negative (SDIn) function state machine.

Value	Description
0	Moving Positive Direction
1	Stopped
2	Delay Before Monitoring
3	Not Running
4	Fault Reaction

Context

For complete SDI information refer to "SDI (Safe Direction)" (→ # 269).

Versions

Action	Version	Notes
Implemented	2-00-00-000	Implemented in SMM revision v0.56

General Information

Type	Read only
Units	NA
Range	0, 1, 2, 3, 4
Default Value	NA
Data Type	Integer
Stored in Non-Volatile Memory	No

9.9.1.30 AXIS#.SAFE.SDIIn.MOTIONACTIVE

Description

Indicates whether the axis is moving in the negative direction or not when Safe Direction negative (SDIn) is not active (when SDIn is active, if the axis cannot move in the negative direction, the fault reaction is activated).

Value	Description
0	Not moving
1	Moving

Context

For complete SDI information refer to "SDI (Safe Direction)" (→ # 269).

Versions

Action	Version	Notes
Implemented	2-04-00-000	Implemented in SMM revision v0.56

General Information

Type	Read Only
Units	NA
Range	0, 1
Default Value	N/A
Data Type	Integer
Stored in Non-Volatile Memory	No

9.9.1.31 AXIS#.SAFE.SDIp.INTERNALSTATE

Description

Indicates the internal state of the Safe Direction positive (SDIp) function state machine.

Value	Description
0	Moving Negative Direction
1	Stopped
2	Delay Before Monitoring
3	Not Running
4	Fault Reaction

Context

For complete SDI information refer to "SDI (Safe Direction)" (→ # 269).

Versions

Action	Version	Notes
Implemented	2-04-00-000	Implemented in SMM revision v0.56

General Information

Type	Read Only
Units	N/A
Range	0, 1, 2, 3, 4
Default Value	N/A
Data Type	Integer
Stored in Non-Volatile Memory	No

9.9.1.32 AXIS#.SAFE.SDIp.MOTIONACTIVE

Description

Indicates whether the axis is moving in the positive direction or not when Safe Direction positive (SDIp) is not active (when SDIp is active, if the axis cannot move in the positive direction, the fault reaction is activated).

Value	Description
0	Not moving
1	Moving

Context

For complete SDI information refer to "SDI (Safe Direction)" (→ # 269).

Versions

Action	Version	Notes
Implemented	2-04-00-000	Implemented in SMM revision v0.56

General Information

Type	Read Only
Units	N/A
Range	0, 1
Default Value	N/A
Data Type	Integer
Stored in Non-Volatile Memory	No

Fieldbus Information

EtherCAT CoE and CANopen

Command	Index	SubIndex	Data Type	Units	Float Scale	Access	PDO Mappable
AXIS1.SAFE.SDIP.MOTIONACTIVE	66deh	01h	Unsigned8	-	-	Read only	Yes
AXIS2.SAFE.SDIP.MOTIONACTIVE	6ede	01h	Unsigned8	-	-	Read only	Yes

9.9.1.33 AXIS#.SAFE.SLA.ACTIVE

Description

Indicates whether the Safely Limited Acceleration (SLA) function instance is active.

Value	Description
0	Not active
1	Active

Context

For complete SLA information refer to "SLA (Safely Limited Acceleration)" (→ # 273).

Versions

Action	Version	Notes
Implemented	2-04-00-000	Implemented in SMM revision v0.56

General Information

Type	Read Only
Units	N/A
Range	0, 1
Default Value	N/A
Data Type	Integer
Stored in Non-Volatile Memory	No

9.9.1.34 AXIS#.SAFE.SLA.INTERNALSTATE

Description

Indicates the internal state of the Safely Limited Acceleration (SLA) function state machine.

Value	Description
0	Not Running
1	Monitoring
2	Fault Reaction

Context

For complete SLA information refer to "SLA (Safely Limited Acceleration)" (→ # 273).

Versions

Action	Version	Notes
Implemented	2-04-00-000	Implemented in SMM revision v0.56

General Information

Type	Read Only
Units	N/A
Range	0, 1, 2, 3
Default Value	N/A
Data Type	Integer
Stored in Non-Volatile Memory	No

9.9.1.35 AXIS#.SAFE.SLI_#.ACTIVE

Description

Indicates whether the Safely Limited Increment (SLI) function instance is active.

Value	Description
0	Not active
1	Active

Context

For complete SLI information refer to "SLI (Safely Limited Increment)" (→ # 280).

Versions

Action	Version	Notes
Implemented	2-04-00-000	Implemented in SMM revision v0.56

General Information

Type	Read Only
Units	N/A
Range	0, 1
Default Value	N/A
Data Type	Integer
Stored in Non-Volatile Memory	No

9.9.1.36 AXIS#.SAFE.SLI_#.INTERNALSTATE

Description

Indicates the internal state of the Safely Limited Increment (SLI) function state machine.

Value	Description
0	Initial
1	Not Running
2	Monitoring
3	Fault Reaction
4	Delay Before Monitoring

Context

For complete SLI information refer to "SLI (Safely Limited Increment)" (→ # 280).

Versions

Action	Version	Notes
Implemented	2-04-00-000	Implemented in SMM revision v0.56

General Information

Type	Read only
Units	N/A
Range	0, 1, 2, 3, 4
Default Value	N/A
Data Type	Integer
Stored in Non-Volatile Memory	No

9.9.1.37 AXIS#.SAFE.SLP_#.ACTIVE

Description

Indicates whether the Safely Limited Position (SLP) function instance is active.

Value	Description
0	Not active
1	Active

Context

For complete SLP information refer to "SLP (Safely Limited Position)" (→ # 283).

Versions

Action	Version	Notes
Implemented	02-04-00-000	Implemented in SMM revision v0.56

General Information

Type	Read Only
Units	N/A
Range	0, 1
Default Value	N/A
Data Type	Integer
Stored in Non-Volatile Memory	No

9.9.1.38 AXIS#.SAFE.SLP_#.INTERNALSTATE

Description

Indicates the internal state of the Safely Limited Position (SLP) function state machine.

Value	Description
0	Not Running
1	Monitoring
2	Fault Reaction
3	Delay Before Monitoring

Context

For complete SLP information refer to "SLP (Safely Limited Position)" (→ # 283).

Versions

Action	Version	Notes
Implemented	02-04-00-000	Implemented in SMM revision v0.56

General Information

Type	Read Only
Units	N/A
Range	0, 1, 2, 3
Default Value	N/A
Data Type	Integer
Stored in Non-Volatile Memory	No

9.9.1.39 AXIS#.SAFE.SLS_#.ACTIVE

Description

Indicates whether the Safely Limited Speed (SLS) instance is active.

Value	Description
0	Not active
1	Active

Context

For complete SLS information refer to "SLS (Safely Limited Speed)" (→ # 261)

Versions

Action	Version	Notes
Implemented	02-04-00-000	Implemented in SMM revision v0.56

General Information

Type	Read Only
Units	N/A
Range	0, 1
Default Value	0 (Idle)
Data Type	Integer
Stored in Non-Volatile Memory	No

9.9.1.40 AXIS#.SAFE.SLS_#.INTERNALSTATE

Description

Indicates the internal state of the Safely Limited Speed (SLS) state machine.

Value	Description
0	Not Running
1	Delay Before Monitoring
2	Target Velocity Not Reached
3	Target Velocity Reached
4	Monitoring
5	Fault reaction

Context

For complete SLS information refer to "SLS (Safely Limited Speed)" (→ # 261)

Versions

Action	Version	Notes
Implemented	02-04-00-000	Implemented in SMM revision v0.56

General Information

Type	Read Only
Units	N/A
Range	0 to 5
Default Value	0 (Idle)
Data Type	Integer
Stored in Non-Volatile Memory	No

9.9.1.41 AXIS#.SAFE.SOS_x.ACTIVE

Description

Indicates whether the Safe Operating Stop (SOS) function instance is active.

Value	Description
0	Not active
1	Active

Context

For complete SOS information refer to SOS (Safe Operating Stop).

Versions

Action	Version	Notes
Implemented	02-04-00-000	Implemented in SMM revision v0.56

General Information

Type	Read Only
Units	N/A
Range	0, 1
Default Value	N/A
Data Type	Integer
Stored in Non-Volatile Memory	No

Fieldbus Information

EtherCAT CoE and CANopen

Command	Index	SubIndex	Data Type	Units	Float Scale	Access	PDO Mappable
AXIS1.SAFE.SOS_2.ACTIVE	666fh	02h	Unsigned8	-	-	Read only	Yes
AXIS2.SAFE.SOS_2.ACTIVE	6e6fh	02h	Unsigned8	-	-	Read only	Yes

9.9.1.42 AXIS#.SAFE.SOS_x.INTERNALSTATE

Description

Indicates the internal state of the Safe Operating Stop (SOS) state machine.

Value	Description
0	Initial
1	Not Running
2	Delay Before Monitoring
3	Monitoring
4	Fault reaction
5	Acknowledge Pending

Context

For complete SOS information refer to SOS (Safe Operating Stop).

Versions

Action	Version	Notes
Implemented	2-04-00-000	Implemented in SMM revision v0.56

General Information

Type	Read Only
Units	N/A
Range	0, 1, 2, 3, 4, 5
Default Value	1 (Idle)
Data Type	Integer
Stored in Non-Volatile Memory	No

9.9.1.43 AXIS#.SAFE.SS1_#.ACTIVE

Description

Indicates whether the specified safe stop instance is active. This signal is set to 1 when Safe Stop 1 (SS1) is activated. When finally SS1 activates the STO function (often after SS1_#.TIMETOSTO but it could be before if you are using a safe encoder), this active signal transition back to 0.

Context

For complete SS1 information refer to (→ # 223) / (→ # 228).

Versions

Action	Version	Notes
Implemented	02-01-02-000	

General Information

Type	Read Only
Units	N/A
Range	0 or 1
Default Value	N/A
Data Type	Integer
Stored in Non-Volatile Memory	No

9.9.1.44 AXIS#.SAFE.SS1_#.DEC

Description

Sets the deceleration rate for the corresponding safe stop instance. When the safe stop instance is executed via safe input or FSoE the drive will attempt to stop following the associated deceleration rate. If multiple safe stop instances occur at the same time, the instance with the fastest deceleration rate will be used.

[If [AXIS#.SAFE.SS1_#.MODE](#) is set to fieldbus control, the drive will not decelerate on its own and this parameter is ignored.

If the deceleration rate is too slow for the configured max. time ([AXIS#.SAFEPARAM.SS1_#.TIMETOSTO](#)), the drive will be disabled via STO. The maximum time, normal operating speed, and the deceleration rate should be configured to ensure the drive stops under control before the time expires.

Context

For complete SS1 information refer to (→ # 223) / (→ # 228).

Versions

Action	Version	Notes
Implemented	02-01-00-000	

General Information

Type	Read/Write
Units	Rotary: RPM/s, RPS/s, deg/s ² , (custom units)/s ² , rad/s ² Linear: counts/s ² , mm/s ² , μm/s ² , (custom units)/s ²
Range	Depends on units.
Default Value	10,000 RPM/s, depends on units.
Data Type	Float
Stored in Non-Volatile Memory	Yes

9.9.1.45 AXIS#.SAFE.SS1_#.INTERNALSTATE

Description

Indicates the internal state of the Safe Stop 1 (SS1) state machine.

SS1-t is executed when the drive is FS2 or “Deceleration & Velocity monitoring” is disabled in the safety parameters.

SS1-r is executed when “Deceleration & Velocity monitoring” is enabled in the safety parameters.

SS1-t		SS1-r	
Value	Description	Value	Description
0	Not Running	0	Not Running
1	Delay Before STO	1	Delay Before Monitoring
		2	Target Velocity Not Reached
		3	Target Velocity Reached
4	STO Activated	4	STO Activated
		5	Fault Reaction

Context

For complete SS1 information refer to (→ # 223) / (→ # 228).

Versions

Action	Version	Notes
Implemented	02-00-00-000	

General Information

Type	Read Only
Units	N/A
Range	0 to 5
Default Value	0 (Idle)
Data Type	Integer
Stored in Non-Volatile Memory	No

9.9.1.46 AXIS#.SAFE.SS1_#.MODE

Description

Sets the behavior of the drive when the corresponding Safe Stop 1 (SS1) input is triggered.

Value	Description
0	Drive Controlled - Drive performs a controlled stop following AXIS#.SAFE.SS1_#.DEC deceleration rate.
1	Fieldbus Controlled - The drive will not perform any stopping action, the fieldbus master should stop the drive within the configured AXIS#.SS1_#.TIMETOSTO amount of time before the drive triggers the STO signal. The manufacturer status object 50EFh is used to signal to the fieldbus master that an SS1 input has been triggered.

Context

For complete SS1 information refer to (→ # 223) / (→ # 228).

Versions

Action	Version	Notes
Implemented	02-01-00-000	

General Information

Type	Read/Write
Units	N/A
Range	0 to 1
Default Value	0 (Drive Controlled)
Data Type	Integer
Stored in Non-Volatile Memory	Yes

9.9.1.47 AXIS#.SAFE.SS2_#.ACTIVE**Description**

Indicates whether the Safe Stop 2 (SS2) safety function is active or not.

Value	Description
0	Not active
1	Active

Context

For complete SS2 information refer to "SS2 (Safe Stop 2)" (→ # 232).

Versions

Action	Version	Notes
Implemented	2-04-00-000	Implemented in SMM revision v0.56

General Information

Type	Read Only
Units	N/A
Range	0, 1
Default Value	0 (Idle)
Data Type	Integer
Stored in Non-Volatile Memory	No

9.9.1.48 AXIS#.SAFE.SS2_#.DEC

Description

Sets the deceleration rate for the corresponding safe stop instance. When the safe stop instance is executed via safe input or FSoE the drive will attempt to stop following the associated deceleration rate. If multiple safe stop instances occur at the same time, the instance with the fastest deceleration rate will be used.

[If [AXISx.SAFE.SS2_x.MODE](#) is set to fieldbus control, the drive will not decelerate on its own and this parameter is ignored.

If the deceleration rate is too slow for the configured max. time ([AXISx.SAFEPARAM.SS2_x.TIMETOSOS](#)), the drive will trigger the configured fault reaction ([AXISx.SAFEPARAM.SS2_x.FAULTREACTION](#)). The maximum time, normal operating speed and the deceleration rate should be configured to ensure the drive stops under control before the time expires.

Context

For complete SS2 information refer to (→ # 232).

Versions

Action	Version	Notes
Implemented	02-04-00-000	Implemented in SMM revision v0.56

General Information

Type	Read/Write
Units	Rotary: RPM/s, RPS/s, deg/s ² , (custom units)/s ² , rad/s ² Linear: counts/s ² , mm/s ² , μm/s ² , (custom units)/s ²
Range	Depends on units.
Default Value	10,000 RPM/s, depends on units.
Data Type	Float
Stored in Non-Volatile Memory	Yes

9.9.1.49 AXIS#.SAFE.SS2_#.INTERNALSTATE

Description

Indicates the internal state of the Safe Stop 2 (SS2) state machine.

Value	Description
0	Not Running
1	Delay Before Monitoring
2	Target Velocity Not Reached
3	Target Velocity Reached
4	SOS Activated
5	Fault Reaction

Context

For complete SS2 information refer to "SS2 (Safe Stop 2)" (→ # 232).

Versions

Action	Version	Notes
Implemented	2-04-00-000	Implemented in SMM revision v0.54

General Information

Type	Read Only
Units	N/A
Range	0, 1, 2, 3, 4, 5
Default Value	0 (Idle)
Data Type	Integer
Stored in Non-Volatile Memory	No

9.9.1.50 AXIS#.SAFE.SS2_#.MODE

Description

Sets the behavior of the drive when the corresponding Safe Stop 2 (SS2) input is triggered.

Value	Description
0	Drive Controlled - Drive performs a controlled stop following AXISx.SAFE.SS2_x.DEC deceleration rate.
1	Fieldbus Controlled - The drive will not perform any stopping action. The fieldbus master should stop the drive within the configured AXISx.SAFEPARAM.SS2_x.TIMETOSOS amount of time before the drive triggers the configured fault reaction. The manufacturer status object is used to signalize to the fieldbus master that an SS2 input has been triggered.

Context

For complete SS2 information refer to (→ # 232).

Versions

Action	Version	Notes
Implemented	02-04-00-000	Implemented in SMM revision v0.56

General Information

Type	Read/Write
Units	N/A
Range	0 to 1
Default Value	Drive controlled
Data Type	Integer
Stored in Non-Volatile Memory	Yes

9.9.1.51 AXIS#.SAFE.SSM_#.INRANGE

Description

Indicates whether the Safe Speed Monitor (SSM) function instance is active.

Value	Description
0	Not active
1	Active

Context

For complete SSM information refer to "SSM (Safe Speed Monitor)" (→ # 264).

Versions

Action	Version	Notes
Implemented	02-04-00-000	Implemented in SMM revision v0.56

General Information

Type	Read Only
Units	N/A
Range	0, 1
Default Value	N/A
Data Type	Integer
Stored in Non-Volatile Memory	No

Fieldbus Information

EtherCAT CoE and CANopen

Command	Index	SubIndex	Data Type	Units	Float Scale	Access	PDO Mappable
AXIS1.SAFE.SSM_1.INRANGE	66e0h	01h	Unsigned8	-	-	Read only	Yes
AXIS1.SAFE.SSM_2.INRANGE	66e0h	02h	Unsigned8	-	-	Read only	Yes
AXIS2.SAFE.SSM_1.INRANGE	6ee0h	01h	Unsigned8	-	-	Read only	Yes
AXIS2.SAFE.SSM_2.INRANGE	6ee0h	02h	Unsigned8	-	-	Read only	Yes

9.9.1.52 AXIS#.SAFE.SSM_#.INTERNALSTATE

Description

Indicates the internal state of the Safe Speed Monitor (SSM) state machine.

Value	Description
0	Velocity is not in range
1	Velocity is in range

Context

For complete SSM information refer to "SSM (Safe Speed Monitor)" (→ # 264).

Versions

Action	Version	Notes
Implemented	02-04-00-000	Implemented in SMM revision v0.56

General Information

Type	Read Only
Units	N/A
Range	0, 1
Default Value	NA
Data Type	Integer
Stored in Non-Volatile Memory	No

9.9.1.53 AXIS#.SAFE.SSR_#.ACTIVE**Description**

Indicates whether the Safe Speed Range (SSR) safety function instance is active or not.

Value	Description
0	Not active
1	Active

Context

For complete SSR information refer to "SSR (Safe Speed Range)" (→ # 266)

Versions

Action	Version	Notes
Implemented	02-04-00-000	Implemented in SMM revision v0.56

General Information

Type	Read Only
Units	N/A
Range	0, 1
Default Value	NA
Data Type	Integer
Stored in Non-Volatile Memory	No

9.9.1.54 AXIS#.SAFE.SSR_#.INTERNALSTATE

Description

Indicates the internal state of the Safe Speed Range (SSR) state machine.

Value	Description
0	Not Running
1	Delay Before Monitoring
2	Target Velocity Not Reached
3	Target Velocity Reached
4	Monitoring
5	Fault Reaction

Context

For complete SSR information refer to "SSR (Safe Speed Range)" (→ # 266).

Versions

Action	Version	Notes
Implemented	02-04-00-000	Implemented in SMM revision v0.56

General Information

Type	Read Only
Units	N/A
Range	0, 1, 2, 3, 4, 5
Default Value	NA
Data Type	Integer
Stored in Non-Volatile Memory	No

9.9.1.55 AXIS#.SAFE.STO.ACTIVE

Description

Indicates the Safe Torque Off (STO) state of the axis.

Value	Description
1	STO active (inputs +0V)
0	STO inactive (inputs 24V)

Context

For complete STO information refer to "STO (Safe Torque Off)" (→ # 219).

Versions

Action	Version	Notes
Implemented	02-00-00-000	

General Information

Type	Read Only
Units	N/A
Range	0 or 1
Default Value	N/A
Data Type	Integer
Stored in Non-Volatile Memory	No

9.9.1.56 AXIS#.SAFE.STO.REPORTFAULT

Description

This parameter controls whether a Safe Torque Off (STO) fault F9000 will be created when STO is activated while the axis is enabled. The STO warning W9000 is always generated if this parameter is 1 and the STO function is active.

Value	Description
1	W9000 / F9000 are generated when axis is enabled and an STO occurs (default)
0	W9000 / F9000 are not generated

Context

For complete STO information refer to "STO (Safe Torque Off)" (→ # 219).

Versions

Action	Version	Notes
Implemented	02-00-00-000	

General Information

Type	Read/Write
Units	N/A
Range	0 or 1
Default Value	1
Data Type	Integer
Stored in Non-Volatile Memory	Yes

9.9.1.57 AXIS#.SAFE.TEMPWARNING.ACTIVE

Description

Indicates whether the SMM temperature is in the expected range.

Value	Description
0	SMM temperature is not in the expected range
1	SMM temperature is ok

Versions

Action	Version	Notes
Implemented	2-00-00-000	Implemented in SMM revision v0.56

General Information

Type	Read Only
Units	N/A
Range	0, 1
Default Value	N/A
Data Type	Integer
Stored in Non-Volatile Memory	No

9.9.1.58 AXIS#.SAFE.VELOCITY

Description

Returns the safe velocity. This only returns a valid value when a safe encoder is attached to the considered axis.

Versions

Action	Version	Notes
Implemented	02-04-00-000	Implemented in SMM revision v0.56

General Information

Type	Read Only
Units	N/A
Range	$[-2^{31}+1, 2^{31}-1]$
Default Value	N/A
Data Type	Integer
Stored in Non-Volatile Memory	No

9.9.1.59 AXIS#.SAFEPARAM.ABSOLUTEPOSEN

Description

Indicates whether the absolute position support is enabled or not. If in use, the absolute position will be valid if the current value read in the encoder by the SMM matches the one stored in its non-volatile memory. If there is a mismatch, the absolute position will be marked as invalid (see [AXIS#.SAFEPARAM.ABSOLUTEPOSVALID](#)) and a safe homing will be required before using function that requires an absolute position (as SLP [Safe Limited Position]).

NOTE

This parameter must be enabled for any functions that needs an absolute position.

Value	Description
0	Disabled
1	Enabled

Context

For safe encoder details refer to "Motor feedback requirements" (→ # 216).

Versions

Action	Version	Notes
Implemented	2-04-00-000	Implemented in SMM revision v0.56

General Information

Type	Read/Write
Units	N/A
Range	0, 1
Default Value	0 (Disabled)
Data Type	Integer
Stored in Non-Volatile Memory	No

9.9.1.60 AXIS#.SAFEPARAM.ABSOLUTEPOSRANGE

Description

Indicates the absolute position range presented to the user. The range can be composed of unsigned values or signed values. This is only usable when a safe encoder is configured in the safety parameters and when the absolute position support is enabled (see [AXIS#.SAFEPARAM.ABSOLUTEPOSEN](#)). The SMM does not extend the position by adding software multi-turn bits. The size of the range is fixed and directly related to the encoder's number of multi-turn bits. The SMM will simply rollover the position if the encoders move outside of the pre-defined range.

Example:

If the encoder has 12 multi-turn bits then the range of absolute position multi-turn bits will be:

- Unsigned: [0,+4095]
- Signed: [-2048,+2047]

You can choose the homing value inside the range using [AXIS#.SAFEPARAM.ABSOLUTEPOSRESETVALUE](#).

Value	Description
0	Unsigned range
1	Signed range

Context

For safe encoder details refer to "Motor feedback requirements" (→ # 216).

Versions

Action	Version	Notes
Implemented	2-04-00-000	Implemented in SMM revision v0.56

General Information

Type	Read/Write
Units	N/A
Range	0, 1
Default Value	0 (Unsigned range)
Data Type	Integer
Stored in Non Volatile Memory	No

9.9.1.61 AXIS#.SAFEPARAM.ABSOLUTEPOSRESETSOURCE

Description

Indicates which inputs perform the safe homing. This is only configurable when the absolute position support is enabled (see [AXIS#.SAFEPARAM.ABSOLUTEPOSEN](#)) and a safe encoder is configured in the safety parameters.

Safe homing is required when [AXIS#.SAFEPARAM.ABSOLUTEPOSVALID](#) returns 0 (invalid). This means that a discrepancy between the position stored inside the SMM non-volatile memory and the absolute position returned by the safe encoder has been found.

Value	Description
0	Not Used
1	Safe Input 1 (SIN1)
2	Safe Input 2 (SIN2)
3	Safe Input 3 (SIN3)
4	Safe Input 4 (SIN4)
5	Safe dual Input 1 (SIN1/SIN2)
6	Safe dual Input 2 (SIN3/SIN4)

Context

For safe encoder details refer to "Motor feedback requirements" (→ # 216).

Versions

Action	Version	Notes
Implemented	2-04-00-000	Implemented in SMM revision v0.56

General Information

Type	Read/Write
Units	N/A
Range	0, 1, 2, 3, 4, 5, 6
Default Value	0 (Not used)
Data Type	Integer
Stored in Non-Volatile Memory	No

Fieldbus Information

EtherCAT CoE and CANopen

Command	Index	SubIndex	Data Type	Units	Float Scale	Access	PDO Mappable
AXIS1.SAFEPARAM.ABSOLUTEPOSRESETSOURCE	3150h	05h	Unsigned 8	-	-	Read/Write	No
AXIS2.SAFEPARAM.ABSOLUTEPOSRESETSOURCE	3250h	05h	Unsigned 8	-	-	Read/Write	No

9.9.1.62 AXIS#.SAFEPARAM.ABSOLUTEPOSRESETVALUE

Description

Indicates the safe homing position. This is only usable when a safe encoder is configured in the safety parameters and when the absolute position support is enabled (see [AXIS#.SAFEPARAM.ABSOLUTEPOSEN](#)). This value must be within the range defined by the encoder multi-turn bits and the parameter [AXIS#.SAFEPARAM.ABSOLUTEPOSRANGE](#). The value must be entered in user units.

Context

For safe encoder details refer to "Motor feedback requirements" (→ # 216).

Versions

Action	Version	Notes
Implemented	2-04-00-000	Implemented in SMM revision v0.56

General Information

Type	Read/Write
Units	User units defined in the safety parameters
Range	Depends on the range and user units
Default Value	0
Data Type	Integer
Stored in Non-Volatile Memory	No

Fieldbus Information

EtherCAT CoE and CANopen

Command	Index	SubIndex	Data Type	Units	Float Scale	Access	PDO Mappable
AXIS1.SAFEPARAM.ABSOLUTEPOSRESETVALUE	3150h	07h	Signed32	-	-	Read/Write	No
AXIS2.SAFEPARAM.ABSOLUTEPOSRESETVALUE	3250h	07h	Signed32	-	-	Read/Write	No

9.9.1.63 AXIS#.SAFEPARAM.ACCCOMPUTATIONINTERVAL

Description

Indicates the time interval used to compute the acceleration in the SMM. This is only applicable when a safe encoder has been configured in the safety parameters.

Context

For safe encoder details refer to "Motor feedback requirements" (→ # 216).

Versions

Action	Version	Notes
Implemented	2-04-00-000	Implemented in SMM revision v0.56

General Information

Type	Read/Write
Units	Milliseconds
Range	[1, 100]
Default Value	1
Data Type	Integer
Stored in Non-Volatile Memory	No

Fieldbus Information

EtherCAT CoE and CANopen

Command	Index	SubIndex	Data Type	Units	Float Scale	Access	PDO Mappable
AXIS1.SAFEPARAM.ACCCOMPUTATIONINTERVAL	3150h	03h	Unsigned 8	-	-	Read/Write	No
AXIS2.SAFEPARAM.ACCCOMPUTATIONINTERVAL	3250h	03h	Unsigned 8	-	-	Read/Write	No

9.9.1.64 AXIS#.SAFEPARAM.AXISCFGEN

Description

Indicates whether the axis is enabled in the safety configuration. This parameter is for information only. It is handled automatically when using safety parameters from WorkBench. When using FSoE parameters the defaults are properly filled out based on single or dual axis EtherCAT product codes.

Versions

Action	Version	Notes
Implemented	02-01-02-000	

General Information

Type	Read/Write
Units	N/A
Range	0 or 1
Default Value	N/A
Data Type	Integer
Stored in Non-Volatile Memory	No

Fieldbus Information

EtherCAT CoE and CANopen

Command	Index	SubIndex	Data Type	Units	Float Scale	Access	PDO Mappable
AXIS1.SAFEPARAM.AXISCFGEN	3100h	02h	Unsigned8	-	-	Read/Write	No
AXIS2.SAFEPARAM.AXISCFGEN	3100h	03h	Unsigned8	-	-	Read/Write	No

9.9.1.65 AXIS#.SAFEPARAM.ENCODERSOURCE

Description

Indicates the encoder interface linked to this axis.

Value	Description
0	No encoder
1	Encoder 1 (HF-DSL)
2	Encoder 2 (HF-DSL)
3	N/A

Context

For safe encoder details refer to "Motor feedback requirements" (→ # 216).

Versions

Action	Version	Notes
Implemented	2-04-00-000	Implemented in SMM revision v0.56

General Information

Type	Read/Write
Units	N/A
Range	0, 1, 2
Default Value	0 (No encoder)
Data Type	Integer
Stored in Non-Volatile Memory	No

Fieldbus Information

EtherCAT CoE and CANopen

Command	Index	SubIndex	Data Type	Units	Float Scale	Access	PDO Mappable
AXIS1.SAFEPARAM.ENCODERSOURCE	3150h	01h	Unsigned8	-	-	Read/Write	No
AXIS2.SAFEPARAM.ENCODERSOURCE	3250h	01h	Unsigned8	-	-	Read/Write	No

9.9.1.66 AXIS#.SAFEPARAM.SAR_#.ACCLOWERLIMIT

Description

Indicates the acceleration lower limit of the Safe Acceleration Range (SAR) safety function.

Context

For complete SAR information refer to "SAR (Safe Acceleration Range)" (→ # 276).

Versions

Action	Version	Notes
Implemented	02-04-00-000	Implemented in SMM revision v0.56

General Information

Type	Read/Write
Units	Depends on user units
Range	$[-2^{31}+1, 2^{31}-1]$
Default Value	1
Data Type	Integer
Stored in Non-Volatile Memory	No

9.9.1.67 AXIS#.SAFEPARAM.SAR_#.ACCUPPERLIMIT**Description**

Indicates the acceleration upper limit of the Safe Acceleration Range (SAR) safety function.

Context

For complete SAR information refer to "SAR (Safe Acceleration Range)" (→ # 276).

Versions

Action	Version	Notes
Implemented	02-04-00-000	Implemented in SMM revision v0.56

General Information

Type	Read/Write
Units	Depends on user units
Range	$[-2^{31}+1, 2^{31}-1]$
Default Value	1
Data Type	Integer
Stored in Non-Volatile Memory	No

9.9.1.68 AXIS#.SAFEPARAM.SAR_#.FAULTREACTION

Description

Indicates the safety function activated when the Safe Acceleration Range (SAR) safety function is faulted. The parameter uses one of the following values:

Value	Description
1	STO
2	SS1 Instance 1
3	SS2 Instance 2

Context

For complete SAR information refer to "SAR (Safe Acceleration Range)" (→ # 276).

Versions

Action	Version	Notes
Implemented	02-04-00-000	Implemented in SMM revision v0.56

General Information

Type	Read/Write
Units	N/A
Range	1, 2, 3
Default Value	1 (STO)
Data Type	Integer
Stored in Non-Volatile Memory	No

9.9.1.69 AXIS#.SAFEPARAM.SAR_#.FSOE

Description

Indicates if the Safe Acceleration Range (SAR) safety function can be activated through FSoE. This parameter is only set to “Used” when FSoE is activated ([SAFEPARAM.SAFEFIELDDBUS.ACTIVATION](#) is set to 1 - “Activated”). When activated, the safety system forbids the axis to move in the negative direction.

Value	Description
0	Not used
1	Used

Context

For complete SAR information refer to "SAR (Safe Acceleration Range)" (→ # 276).

Versions

Action	Version	Notes
Implemented	02-04-00-000	Implemented in SMM revision v0.56

General Information

Type	Read/Write
Units	N/A
Range	0, 1
Default Value	0 (Not used)
Data Type	Integer
Stored in Non-Volatile Memory	No

9.9.1.70 AXIS#.SAFEPARAM.SAR_#.FUNCTIONACTIVATION

Description

Indicates whether the Safe Acceleration Range (SAR) safety functions can be activated. One of the following values are used:

Value	Description
0	Never active
1	Read for activation

These functions can only be used when a safe encoder is configured in the safety parameters.

Context

For complete SAR information refer to "SAR (Safe Acceleration Range)" (→ # 276).

Versions

Action	Version	Notes
Implemented	02-04-00-000	Implemented in SMM revision v0.56

General Information

Type	Read/Write
Units	N/A
Range	0, 1
Default Value	0 (Never active)
Data Type	Integer
Stored in Non-Volatile Memory	No

9.9.1.71 AXIS#.SAFEPARAM.SAR_#.SAFEINPUT

Description

Indicates which safe input can activate the Safe Acceleration Range (SAR) safety function.

Value	Description
0	Not used
1	Safe Input 1 (SIN1)
2	Safe Input 2 (SIN2)
3	Safe Input 3 (SIN3)
4	Safe Input 4 (SIN4)
5	Safe dual input 1 (SIN1/SIN2)
6	Safe dual input 2 (SIN3/SIN4)

Context

For complete SAR information refer to "SAR (Safe Acceleration Range)" (→ # 276).

Versions

Action	Version	Notes
Implemented	02-04-00-000	Implemented in SMM revision v0.56

General Information

Type	Read/Write
Units	N/A
Range	0 - 6
Default Value	0 (Not used)
Data Type	Integer
Stored in Non-Volatile Memory	No

9.9.1.72 AXIS#.SAFEPARAM.SBC.BRAKETIMEDELAY

Description

Indicates the delay required to apply the brake.

If the brake is configured without SDB (Safe Dynamic Brake) (brake before STO [Safe Torque Off]), the drive stays energized for the delay time once stopped to hold position and waits for the brake to apply before de-energizing the power stage.

If the brake is configured with SDB (brake simultaneously with STO), the delay time does not have any effect.

To ensure proper brake operation, this parameter should be the same or longer than the AXIS#.MOTOR.TBRAKEAPP time.

NOTICE

Ensure that the delay specified is enough time for the brake to fully engage. If an STO occurs prior to the brake fully engaged and the power stage is disabled, the axis load may fall.

Context

For complete SBC information refer to "SBC (Safe Brake Control)" (→ # 240).

Versions

Action	Version	Notes
Implemented	02-01-02-000	

General Information

Type	Read/Write
Units	ms
Range	1-60,000 ms
Default Value	100 ms
Data Type	Integer
Stored in Non-Volatile Memory	No

9.9.1.73 AXIS#.SAFEPARAM.SBC.BRAKE#ATTACHED

Description

Indicates whether Safe Brake Control (SBC) is enabled on this axis. Axis 1 can have SBC enabled with two assigned brakes. Axis 2 can only have SBC enabled with one brake (ie: BRAKE2ATTACHED cannot be set).

Value	Description
0	No brake configured
1	Brake attached – without SDB (brake is applied before STO occurs according to 9.9.1.72 "AXIS#.SAFEPARAM.SBC.BRAKETIMEDELAY")
2	Brake attached – with SDB (brake is applied after STO occurs)

NOTE

If (see AXIS#.MOTOR.BRAKE) and (see BRAKE#.AXIS) indicates no brake is attached to the axis but this safety parameter indicates a brake is attached, a warning will occur.

NOTE

NOTE

It is allowed to have a brake configured on the axis without enabling SBC using (see AXIS#.MOTOR.BRAKE) and (see BRAKE#.AXIS).

NOTE

Context

For complete SBC information refer to "SBC (Safe Brake Control)" (→ # 240).

Versions

Action	Version	Notes
Implemented	02-00-00-000	

General Information

Type	Read/Write
Units	N/A
Range	0, 1, 2
Default Value	0 (on FSoE only)
Data Type	Integer
Stored in Non-Volatile Memory	No

9.9.1.74 AXIS#.SAFEPARAM.SBC.MUTINGSOURCE

Description

This parameter allows the user to specify a safe input to bypass Safe Brake Control (SBC) and permit the brake to release regardless of whether SBC is active or not. The feature is referred to as 'SBC Muting' in documentation and WorkBench.

Value	Description
0	Not used
1	Safe input 1
2	Safe input 2
3	Safe input 3
4	Safe input 4
5	Safe dual input 1
6	Safe dual input 2

NOTE

If using this feature, make sure it is safe to release the brake and there is not a heavy load being held solely by the brake.

Context

For complete SBC information refer to "SBC (Safe Brake Control)" (→ # 240).

Versions

Action	Version	Notes
Implemented	02-01-02-000	

General Information

Type	Read/Write
Units	N/A
Range	0 or 6
Default Value	N/A
Data Type	Integer
Stored in Non- Volatile Memory	No

9.9.1.75 AXIS#.SAFEPARAM.SBT.FUNCTIONACTIVATION

Description

Indicates whether Safe Brake Test (SBT) can be activated. When ready for activation and SBT has not been run within the specified interval, a warning is activated indicating the need to run SBT. When the SBT is set to never be active, it is not possible to execute the safe brake test while there is no warning activated for SBT.

Value	Description
0	Never active
1	Ready for activation

Context

For complete SBT information refer to "SBT (Safe Brake Test)" (→ # 249).

Versions

Action	Version	Notes
Implemented	2-00-00-000	Implemented in SMM revision v0.54

General Information

Type	Read/Write
Units	N/A
Range	0, 1
Default Value	0
Data Type	Integer
Stored in Non-Volatile Memory	No

9.9.1.76 AXIS#.SAFEPARAM.SBT.MAXAPPLLOAD

Description

Specifies the maximum load of the application reflected to the motor shaft converted to current in mA. This value is scalar without regard to direction. It defines the 100% maximum application load. The Safe Brake Test (SBT) is done with 130% of maximum load (current).

Context

For complete SBT information refer to "SBT (Safe Brake Test)" (→ # 249).

Versions

Action	Version	Notes
Implemented	02-01-02-000	

General Information

Type	Read/Write
Units	mA
Range	1 – 200000 mA
Default Value	1000 mA (1 amp)
Data Type	Integer
Stored in Non-Volatile Memory	No

9.9.1.77 AXIS#.SAFEPARAM.SBT.MAXMOTIONBRAKE#

Description

Indicates the amount of rotation that should occur for the shaft attached to the specified brake. If the amount of motion detected is larger than this specified amount, the Safe Brake Test (SBT) will enter a failed state and the Safe Brake Acknowledge (SBA) signal is low.

NOTE

The drive will still be allowed to be enabled and command motion. It is up to the safety system to prevent motion in the event of a failed/expired SBT (ie: SBA signal).

Context

For complete SBT information refer to "SBT (Safe Brake Test)" (→ # 249).

Versions

Action	Version	Notes
Implemented	02-01-02-000	

General Information

Type	Read/Write
Units	Arc minutes
Range	1 to 10500 arc minutes
Default Value	300 arc minutes
Data Type	Integer
Stored in Non-Volatile Memory	No

9.9.1.78 AXIS#.SAFEPARAM.SBT.MAXTIMEINTERVAL

Description

Indicates the time in minutes that Safe Brake Test (SBT) must be executed before a warning becomes active that indicates SBT should be run and the Safe Brake Acknowledge (SBA) signal becomes low.

NOTE

If the SBT period has elapsed the drive will permit enabling and movement. It is up to the safety system design to prevent motion, if required.

Context

For complete SBT information refer to "SBT (Safe Brake Test)" (→ # 249).

Versions

Action	Version	Notes
Implemented	02-01-02-000	

General Information

Type	Read/Write
Units	Minutes
Range	1 – 480 minutes
Default Value	480 minutes
Data Type	Integer
Stored in Non-Volatile Memory	No

9.9.1.79 AXIS#.SAFEPARAM.SBT.TORQUEDURATION**Description**

Indicates the duration in milliseconds that current is applied to the motor with the brake applied during the Safe Brake Test (SBT).

Context

For complete SBT information refer to "SBT (Safe Brake Test)" (→ # 249).

Versions

Action	Version	Notes
Implemented	02-01-02-000	

General Information

Type	Read/Write
Units	ms
Range	500 ms to 60000 ms
Default Value	500 ms
Data Type	Integer
Stored in Non-Volatile Memory	No

9.9.1.80 AXIS#.SAFEPARAM.SCA_#.FUNCTIONACTIVATION

Description

Indicates whether the Safe CAm (SCA) safety function can be activated. One of the following values is used:

Value	Description
0	Never active
2	Always activated

This function can only be used when a safe encoder is configured in the safety parameters. This function cannot be activated by using a safe input or FSoE.

Context

For complete SCA information refer to "SCA (Safe Cam)" (→ # 286).

Versions

Action	Version	Notes
Implemented	2-04-00-000	Implemented in SMM revision v0.56

General Information

Type	Read/Write
Units	N/A
Range	0, 2
Default Value	0 (Never Active)
Data Type	Integer
Stored in Non-Volatile Memory	No

9.9.1.81 AXIS#.SAFEPARAM.SCA_#.POSLOWERLIMIT

Description

Indicates the absolute position lower limit of the Safe CA_m (SCA) safety function.

Context

For complete SCA information refer to "SCA (Safe Cam)" (→ # 286).

Versions

Action	Version	Notes
Implemented	2-04-00-000	Implemented in SMM revision v0.56

General Information

Type	Read/Write
Units	Depends on user units
Range	$[-2^{31}+1, 2^{31}-1]$
Default Value	1
Data Type	Integer
Stored in Non-Volatile Memory	No

9.9.1.82 AXIS#.SAFEPARAM.SCA_#.POSUPPERLIMIT

Description

Indicates the absolute position upper limit of the Safe CAm (SCA) safety function.

Context

For complete SCA information refer to "SCA (Safe Cam)" (→ # 286).

Versions

Action	Version	Notes
Implemented	2-04-00-000	Implemented in SMM revision v0.56

General Information

Type	Read/Write
Units	Depends on user units
Range	$[-2^{31}+1, 2^{31}-1]$
Default Value	1
Data Type	Integer
Stored in Non-Volatile Memory	No

9.9.1.83 AXIS#.SAFEPARAM.SDB.DELAYBEFORESWITCHING**Description**

Indicates the time in milliseconds from STO being activated until the Safe Dynamic Brake (SDB) relay is energized.

Context

For complete SDB information refer to "SDB (Safe Dynamic Brake)" (→ # 255).

Versions

Action	Version	Notes
Implemented	02-00-00-000	

General Information

Type	Read/Write
Units	Milliseconds
Range	1 ms to 60,000 ms
Default Value	1 ms
Data Type	Integer
Stored in Non-Volatile Memory	No

9.9.1.84 AXIS#.SAFEPARAM.SDB.FUNCTIONACTIVATION

Description

Indicates whether Safe Dynamic Brake (SDB) is ready for activation.

Value	Description
0	Never active
1	Ready for activation

Context

For complete SDB information refer to "SDB (Safe Dynamic Brake)" (→ # 255).

Versions

Action	Version	Notes
Implemented	02-00-00-000	Implemented in SMM revision v0.54

General Information

Type	Read/Write
Units	N/A
Range	0, 1
Default Value	0 (Never active)
Data Type	Integer
Stored in Non -Volatile Memory	No

9.9.1.85 AXIS#.SAFEPARAM.SDB.READBACKSOURCE

Description

Indicates the digital input that is used for the read back input.

Value	Description
0	Not used
1	Safe Input 1
2	Safe Input 2
3	Safe Input 3
4	Safe Input 4
5	Safe dual input 1
6	Safe dual input 2

Context

For complete SDB information, refer to "SDB (Safe Dynamic Brake)" (→ # 255).

Versions

Action	Version	Notes
Implemented	02-00-00-000	

General Information

Type	Read/Write
Units	N/A
Range	0 or 6
Default Value	0 (Not used)
Data Type	Integer
Stored in Non-Volatile Memory	No

9.9.1.86 AXIS#.SAFEPARAM.SDI.FAULTREACTION

Description

Indicates the safety function activated when the Safe Direction (SDI) safety function is faulted. The parameter can take one of the following values:

Value	Description
1	STO
2	SS1 Instance 1
3	SS2 Instance 1

Context

For complete SDI information refer to "SDI (Safe Direction)" (→ # 269)

Versions

Action	Version	Notes
Implemented	2-04-00-000	Implemented in SMM revision v0.56

General Information

Type	Read/Write
Units	N/A
Range	1, 2, 3
Default Value	1 (STO)
Data Type	Integer
Stored in Non-Volatile Memory	No

9.9.1.87 AXIS#.SAFEPARAM.SDI.FUNCTIONACTIVATION

Description

Indicates whether the Safe Direction (SDI) safety functions can be activated. This applies for both SDIp (positive) and SDIn (negative). One of the following values can be used:

Value	Description
0	Never active
1	Ready for activation

This function can only be used when a safe encoder is configured in the safety parameters.

Context

For complete SDI information refer to "SDI (Safe Direction)" (→ # 269)

Versions

Action	Version	Notes
Implemented	2-04-00-000	Implemented in SMM revision v0.56

General Information

Type	Read/Write
Units	N/A
Range	0, 1
Default Value	0 (Never active)
Data Type	Integer
Stored in Non-Volatile Memory	No

9.9.1.88 AXIS#.SAFEPARAM.SDI.POSZEROWINDOW

Description

Indicates the position window of Safe Direction (SDI) safety functions. This applies to both SDIp (positive) and SDIn (negative) functions.

Context

For complete SDI information refer to "SDI (Safe Direction)" (→ # 269).

Versions

Action	Version	Notes
Implemented	2-04-00-000	Implemented in SMM revision v0.56

General Information

Type	Read/Write
Units	Depends on user units
Range	[1, 2 ³¹ -1]
Default Value	1
Data Type	Integer
Stored in Non-Volatile Memory	No

9.9.1.89 AXIS#.SAFEPARAM.SDI.VELZEROWINDOW**Description**

Indicates the velocity window of the safe direction (SDI) safety functions. This applies to both SDIp (positive) and SDIn (negative) functions.

Context

For complete SDI information refer to "SDI (Safe Direction)" (→ # 269)

Versions

Action	Version	Notes
Implemented	2-04-00-000	Implemented in SMM revision v0.56

General Information

Type	Read/Write
Units	Depends on user units
Range	[1, 2 ³¹ -1]
Default Value	1
Data Type	Integer
Stored in Non-Volatile Memory	No

9.9.1.90 AXIS#.SAFEPARAM.SDIIn.FSOE

Description

Indicates if the Safe Direction negative (SDIn) safety function can be activated through FSoE. This parameter can only be set to "Used" when FSoE is activated ([SAFEPARAM.SAFEFIELDBUS.ACTIVATION](#) is set to 1 - "Activated"). When activated, the safety system forbids the axis to move in the negative direction.

Value	Description
0	Not used
1	Used

Context

For complete SDI information refer to "SDI (Safe Direction)" (→ # 269)

Versions

Action	Version	Notes
Implemented	2-00-00-000	Implemented in SMM revision v0.56

General Information

Type	Read/Write
Units	N/A
Range	0, 1
Default Value	0 (Not used)
Data Type	Integer
Stored in Non-Volatile Memory	No

9.9.1.91 AXIS#.SAFEPARAM.SDIIn.SAFEINPUT

Description

Indicates which safe input can activate the Safe Direction negative (SDIn) safety function. When activated, the safety system forbids the axis to move in the negative direction.

Value	Description
0	Not used
1	Safe Input 1 (SIN1)
2	Safe Input 2 (SIN2)
3	Safe Input 3 (SIN3)
4	Safe Input 4 (SIN4)
5	Safe Dual Input 1 (SIN1/SIN2)
6	Safe Dual Input 2 (SIN3/SIN4)

Context

For complete SDI information refer to "SDI (Safe Direction)" (→ # 269)

Versions

Action	Version	Notes
Implemented	2-00-00-000	Implemented in SMM revision v0.56

General Information

Type	Read/Write
Units	N/A
Range	0 - 6
Default Value	0 (Not used)
Data Type	Integer
Stored in Non-Volatile Memory	No

9.9.1.92 AXIS#.SAFEPARAM.SDIIn.TIMEDELAYMONITORING

Description

Indicates the delay before starting the position and velocity monitoring when the Safe Direction negative (SDIn) safety function is activated.

Context

For complete SDI information refer to "SDI (Safe Direction)" (→ # 269)

Versions

Action	Version	Notes
Implemented	2-04-00-000	Implemented in SMM revision v0.56

General Information

Type	Read/Write
Units	Milliseconds
Range	[0, 60000]
Default Value	1
Data Type	Integer
Stored in Non-Volatile Memory	No

9.9.1.93 AXIS#.SAFEPARAM.SDIp.FSOE

Description

Indicates if the Safe Direction positive (SDIp) safety function can be activated through FSoE. This parameter can only set to “Used” when FSoE is activated ([SAFEPARAM.SAFEFIELDBUS.ACTIVATION](#) is set to 1 - “Activated”). When activated, the safety system forbids the axis to move in the positive direction.

Value	Description
0	Not used
1	Used

Context

For complete SDI information refer to "SDI (Safe Direction)" (→ # 269)

Versions

Action	Version	Notes
Implemented	2-00-00-000	Implemented in SMM revision v0.56

General Information

Type	Read/Write
Units	N/A
Range	0, 1
Default Value	0 (Not used)
Data Type	Integer
Stored in Non-Volatile Memory	No

9.9.1.94 AXIS#.SAFEPARAM.SDIp.SAFEINPUT

Description

Indicates which safe input can activate the Safe Direction positive (SDIp) safety function. When activated, this safety system forbids the axis to move in the positive direction.

Value	Description
0	Not used
1	Safe Input 1 (SIN1)
2	Safe Input 2 (SIN2)
3	Safe Input 3 (SIN3)
4	Safe Input 4 (SIN4)
5	Safe Dual Input 1 (SIN1/SIN2)
6	Safe Dual Input 2 (SIN3/SIN4)

Context

For complete SDI information refer to "SDI (Safe Direction)" (→ # 269)

Versions

Action	Version	Notes
Implemented	2-00-00-000	Implemented in SMM revision v0.56

General Information

Type	Read/Write
Units	N/A
Range	0 - 6
Default Value	0 (Not used)
Data Type	Integer
Stored in Non-Volatile Memory	No

SDIp

EtherCAT CoE and CANopen

Command	Index	SubIndex	Data Type	Units	Float Scale	Access	PDO Mappable
AXIS1.SAFEPARAM.SDIP.SAFEINPU T	3164h	02h	Unsigned8	-	-	Read/Write	No
AXIS2.SAFEPARAM.SDIP.SAFEINPU T	3264h	02h	Unsigned8	-	-	Read/Write	No

9.9.1.95 AXIS#.SAFEPARAM.SDIp.TIMEDELAYMONITORING

Description

Indicates the delay before starting the position and velocity monitoring when the Safe Direction positive (SDIp) safety function is activated.

Context

For complete SDI information refer to "SDI (Safe Direction)" (→ # 269)

Versions

Action	Version	Notes
Implemented	2-04-00-000	Implemented in SMM revision v0.56

General Information

Type	Read/Write
Units	Milliseconds
Range	[1, 60000]
Default Value	1
Data Type	Integer
Stored in Non-Volatile Memory	No

9.9.1.96 AXIS#.SAFEPARAM.SLA.ACCLIMIT

Description

Indicates the acceleration limit of the Safely Limited Acceleration (SLA) safety function.

Context

For complete SLA information refer to "SLA (Safely Limited Acceleration)" (→ # 273).

Versions

Action	Version	Notes
Implemented	2-00-00-000	Implemented in SMM revision v0.56

General Information

Type	Read/Write
Units	Depends on user units
Range	[1, 2 ³¹ -1]
Default Value	1
Data Type	Integer
Stored in Non-Volatile Memory	No

9.9.1.97 AXIS#.SAFEPARAM.SLA.FAULTREACTION

Description

Indicates the safety function activated when the Safely Limited Acceleration (SLA) safety function is faulted. The parameter can use one of the following values:

Value	Description
1	STO
2	SS1 Instance 1
3	SS2 Instance 1

Context

For complete SLA information refer to "SLA (Safely Limited Acceleration)" (→ # 273).

Versions

Action	Version	Notes
Implemented	2-04-00-000	Implemented in SMM revision v0.56

General Information

Type	Read/Write
Units	N/A
Range	1, 2, 3
Default Value	1 (STO)
Data Type	Integer
Stored in Non-Volatile Memory	No

9.9.1.98 AXIS#.SAFEPARAM.SLA.FSOE

Description

Indicates if the Safely Limited Acceleration (SLA) safety function can be activated through FSoE. This parameter can only set to “Used” when FSoE is activated ([SAFEPARAM.SAFEFIELDDBUS.ACTIVATION](#) is set to 1 - “Activated”). When activated, the safety system forbids the axis to move in a negative direction.

Value	Description
0	Not used
1	Used

Context

For complete SLA information refer to "SLA (Safely Limited Acceleration)" (→ # 273).

Versions

Action	Version	Notes
Implemented	2-04-00-000	Implemented in SMM revision v0.56

General Information

Type	Read/Write
Units	N/A
Range	0, 1
Default Value	0 (Not used)
Data Type	Integer
Stored in Non-Volatile Memory	No

9.9.1.99 AXIS#.SAFEPARAM.SLA.FUNCTIONACTIVATION

Description

Indicates whether the Safely Limited Acceleration (SLA) safety functions can be activated. One of the following values is used:

Value	Description
0	Never active
1	Ready for activation
2	Always activated

This function can only be used when a safe encoder is configured in the safety parameters.

Context

For complete SLA information refer to "SLA (Safely Limited Acceleration)" (→ # 273).

Versions

Action	Version	Notes
Implemented	2-04-00-000	Implemented in SMM revision v0.56

General Information

Type	Read/Write
Units	N/A
Range	0, 1, 2
Default Value	0 (Never active)
Data Type	Integer
Stored in Non-Volatile Memory	No

9.9.1.100 AXIS#.SAFEPARAM.SLA.SAFEINPUT

Description

Indicates which safe input can activate the Safely Limited Acceleration (SLA) safety function.

Value	Description
0	Not used
1	Safe Input 1 (SIN1)
2	Safe Input 2 (SIN2)
3	Safe Input 3 (SIN3)
4	Safe Input 4 (SIN4)
5	Safe dual input 1 (SIN1/SIN2)
6	Safe dual input 2 (SIN3/SIN4)

Context

For complete SLA information refer to "SLA (Safely Limited Acceleration)" (→ # 273).

Versions

Action	Version	Notes
Implemented	02-04-00-000	Implemented in SMM revision v0.56

General Information

Type	Read/Write
Units	N/A
Range	0, 1, 2, 3, 4, 5, 6
Default Value	0 (Not used)
Data Type	Integer
Stored in Non-Volatile Memory	No

EtherCAT CoE and CANopen

Command	Index	SubIndex	Data Type	Units	Float Scale	Access	PDO Mappable
AXIS1.SAFEPARAM.SLA.SAFEINPU T	3165h	02h	Unsigned8	-	-	Read/Write	No
AXIS2.SAFEPARAM.SLA.SAFEINPU T	3265h	02h	Unsigned8	-	-	Read/Write	No

9.9.1.101 AXIS#.SAFEPARAM.SLI_#.FAULTREACTION

Description

Indicates the safety function activated when the Safely Limited Increment (SLI) safety function is faulted. The parameter uses one of the following values:

Value	Description
1	STO
2	SS1 Instance 1
3	SS2 Instance 1

Context

For complete SLI information refer to "SLI (Safely Limited Increment)" (→ # 280).

Versions

Action	Version	Notes
Implemented	2-04-00-000	Implemented in SMM revision v0.56

General Information

Type	Read/Write
Units	N/A
Range	1, 2, 3
Default Value	1 (STO)
Data Type	Integer
Stored in Non-Volatile Memory	No

9.9.1.102 AXIS#.SAFEPARAM.SLI_#.FSOE

Description

Indicates if the Safely Limited Increment (SLI) safety function can be activated through FSoE. This parameter can only set to "Used" when FSoE is activated ([SAFEPARAM.SAFEFIELDBUS.ACTIVATION](#) is set to 1 - "Activated").

Value	Description
0	Not used
1	Used

Context

For complete SLI information refer to "SLI (Safely Limited Increment)" (→ # 280).

Versions

Action	Version	Notes
Implemented	02-04-00-000	Implemented in SMM revision v0.56

General Information

Type	Read/Write
Units	N/A
Range	0, 1
Default Value	0 (Not used)
Data Type	Integer
Stored in Non-Volatile Memory	No

9.9.1.103 AXIS#.SAFEPARAM.SLI_#.FUNCTIONACTIVATION

Description

Indicates whether the Safely Limited Increment (SLI) safety function can be activated. This function can only be used when a safe encoder is configured in the safety parameters. One of the following values can be used:

Value	Description
0	Never active
1	Ready for activation

Context

For complete SLI information refer to "SLI (Safely Limited Increment)" (→ # 280).

Versions

Action	Version	Notes
Implemented	2-04-00-000	Implemented in SMM revision v0.56

General Information

Type	Read/Write
Units	N/A
Range	0, 1
Default Value	0 (Never active)
Data Type	Integer
Stored in Non-Volatile Memory	No

9.9.1.104 AXIS#.SAFEPARAM.SLI_#.POSRELOWERLIMIT

Description

Indicates the relative position lower limit of the Safely Limited Increment (SLI) safety function.

Context

For complete SLI information refer to "SLI (Safely Limited Increment)" (→ # 280).

Versions

Action	Version	Notes
Implemented	02-04-00-000	Implemented in SMM revision v0.56

General Information

Type	Read/Write
Units	Depends on user units
Range	[1, 2 ³¹ -1]
Default Value	1
Data Type	Integer
Stored in Non-Volatile Memory	No

9.9.1.105 AXIS#.SAFEPARAM.SLI_#.POSRELUPPERLIMIT**Description**

Indicates the relative position upper limit of the Safely Limited Increment (SLI) safety function.

Context

For complete SLI information refer to "SLI (Safely Limited Increment)" (→ # 280).

Versions

Action	Version	Notes
Implemented	02-04-00-000	Implemented in SMM revision v0.56

General Information

Type	Read/Write
Units	Depends on user units
Range	[1, 2 ³¹ -1]
Default Value	1
Data Type	Integer
Stored in Non-Volatile Memory	No

9.9.1.106 AXIS#.SAFEPARAM.SLI_#.SAFEINPUT

Description

Indicates which safe input can activate the Safely Limited Increment (SLI) safety function.

Value	Description
0	Not used
1	Safe Input 1 (SIN1)
2	Safe Input 2 (SIN2)
3	Safe Input 3 (SIN3)
4	Safe Input 4 (SIN4)
5	Safe dual input 1 (SIN1/SIN2)
6	Safe dual input 2 (SIN3/SIN4)

Context

For complete SLI information refer to "SLI (Safely Limited Increment)" (→ # 280).

Versions

Action	Version	Notes
Implemented	02-04-00-000	Implemented in SMM revision v0.56

General Information

Type	Read/Write
Units	N/A
Range	0, 1, 2, 3, 4, 5, 6
Default Value	0 (Not used)
Data Type	Integer
Stored in Non-Volatile Memory	No

9.9.1.107 AXIS#.SAFEPARAM.SLI_#.TIMEDELAYMONITORING**Description**

Indicates the delay before starting the position monitoring when the Safely Limited Increment (SLI) safety function is activated.

Context

For complete SLI information refer to "SLI (Safely Limited Increment)" (→ # 280).

Versions

Action	Version	Notes
Implemented	02-04-00-000	Implemented in SMM revision v0.56

General Information

Type	Read/Write
Units	Milliseconds
Range	[0, 60000]
Default Value	0
Data Type	Integer
Stored in Non-Volatile Memory	No

9.9.1.108 AXIS#.SAFEPARAM.SLP_#.FAULTREACTION

Description

Indicates the safety function activated when the Safely Limited Position (SLP) safety function is faulted. The parameter uses one of the following values:

Value	Description
1	STO
2	SS1 Instance 1
3	SS2 Instance 1

Context

For complete SLP information refer to "SLP (Safely Limited Position)" (→ # 283).

Versions

Action	Version	Notes
Implemented	2-04-00-000	Implemented in SMM revision v0.56

General Information

Type	Read/Write
Units	N/A
Range	1, 2, 3
Default Value	1 (STO)
Data Type	Integer
Stored in Non-Volatile Memory	No

9.9.1.109 AXIS#.SAFEPARAM.SLP_#.FSOE

Description

Indicates if the Safely Limited Position (SLP) safety function can be activated through FSoE. This parameter can only set to "Used" when FSoE is activated ("SAFEPARAM.SAFEFIELDDBUS.ACTIVATION" (→ # 534) is set to 1 - "Activated"). This function requires the absolute position support to be enabled (see "AXIS#.SAFEPARAM.ABSOLUTEPOSEN" (→ # 386)). If the absolute position support is enabled but not valid (see "AXIS#.SAFE.ABSOLUTEPOSVALID" (→ # 329)) then a safe homing must be performed.

Value	Description
0	Not used
1	Used

Context

For complete SLP information refer to "SLP (Safely Limited Position)" (→ # 283).

Versions

Action	Version	Notes
Implemented	02-04-00-000	Implemented in SMM revision v0.56

General Information

Type	Read/Write
Units	N/A
Range	0, 1
Default Value	0 (Not used)
Data Type	Integer
Stored in Non-Volatile Memory	No

9.9.1.110 AXIS#.SAFEPARAM.SLP_#.FUNCTIONACTIVATION

Description

Indicates whether the Safely Limited Position (SLP) safety function can be activated. This function can only be used when a safe encoder is configured in the safety parameters. This function requires the absolute position to be enabled (see [AXIS#.SAFEPARAM.ABSOLUTEPOSEN](#)). If the absolute position is enabled but not valid (see [AXIS#.SAFEPARAM.ABSOLUTEPOSVALID](#)) then a safe homing must be performed. One of the following values are used:

Value	Description
0	Never active
1	Used
2	Always Activated

Context

For complete SLP information refer to "SLP (Safely Limited Position)" (→ # 283).

Versions

Action	Version	Notes
Implemented	02-04-00-000	Implemented in SMM revision v0.56

General Information

Type	Read/Write
Units	N/A
Range	0, 1, 2
Default Value	0 (Never active)
Data Type	Integer
Stored in Non-Volatile Memory	No

9.9.1.111 AXIS#.SAFEPARAM.SLP_#.POSLOWERLIMIT**Description**

Indicates the absolute position lower limit of the Safely Limited Position (SLP) safety function.

Context

For complete SLP information refer to "SLP (Safely Limited Position)" (→ # 283).

Versions

Action	Version	Notes
Implemented	02-04-00-000	Implemented in SMM revision v0.56

General Information

Type	Read/Write
Units	Depends on user units
Range	$[-2^{31}+1, 2^{31}-1]$
Default Value	1
Data Type	Integer
Stored in Non-Volatile Memory	No

9.9.1.112 AXIS#.SAFEPARAM.SLP_#.POSUPPERLIMIT

Description

Indicates the absolute position upper limit of the Safely Limited Position (SLP) safety function.

Context

For complete SLP information refer to "SLP (Safely Limited Position)" (→ # 283).

Versions

Action	Version	Notes
Implemented	02-04-00-000	Implemented in SMM revision v0.56

General Information

Type	Read/Write
Units	Depends on user units
Range	$[-2^{31}+1, 2^{31}-1]$
Default Value	1
Data Type	Integer
Stored in Non-Volatile Memory	No

9.9.1.113 AXIS#.SAFEPARAM.SLP_#.SAFEINPUT

Description

Indicates which safe input can activate the Safely Limited Position (SLP) safety function. This function requires the absolute position to be enabled (see [AXIS#.SAFEPARAM.ABSOLUTEPOSEN](#)). If the absolute position is enabled but not valid (see [AXIS#.SAFEPARAM.ABSOLUTEPOSVALID](#)) then a safe homing must be performed.

Value	Description
0	Not used
1	Safe Input 1 (SIN1)
2	Safe Input 2 (SIN2)
3	Safe Input 3 (SIN3)
4	Safe Input 4 (SIN4)
5	Safe dual input 1 (SIN1/SIN2)
6	Safe dual input 2 (SIN3/SIN4)

Context

For complete SLP information refer to "SLP (Safely Limited Position)" (→ # 283).

Versions

Action	Version	Notes
Implemented	02-04-00-000	Implemented in SMM revision v0.56

General Information

Type	Read/Write
Units	N/A
Range	0, 1, 2, 3, 4, 5, 6
Default Value	0 (Not used)
Data Type	Integer
Stored in Non-Volatile Memory	No

9.9.1.114 AXIS#.SAFEPARAM.SLP_#.TIMEDELAYMONITORING

Description

Indicates the delay before starting the position monitoring when the Safely Limited Position (SLP) safety function is activated.

Context

For complete SLP information refer to "SLP (Safely Limited Position)" (→ # 283).

Versions

Action	Version	Notes
Implemented	02-04-00-000	Implemented in SMM revision v0.56

General Information

Type	Read/Write
Units	Milliseconds
Range	[0, 60000]
Default Value	0
Data Type	Integer
Stored in Non-Volatile Memory	No

Fieldbus Information

EtherCAT CoE and CANopen

Command	Index	SubIndex	Data Type	Units	Float Scale	Access	PDO Mappable
AXIS1.SAFEPARAM.SLP_1.TIMEDELAYMONITORING	316ch	06h	Unsigned16	-	-	Read/Write	No
AXIS1.SAFEPARAM.SLP_2.TIMEDELAYMONITORING	316dh	06h	Unsigned16	-	-	Read/Write	No
AXIS1.SAFEPARAM.SLP_3.TIMEDELAYMONITORING	316eh	06h	Unsigned16	-	-	Read/Write	No
AXIS2.SAFEPARAM.SLP_1.TIMEDELAYMONITORING	326ch	06h	Unsigned16	-	-	Read/Write	No
AXIS2.SAFEPARAM.SLP_2.TIMEDELAYMONITORING	326dh	06h	Unsigned16	-	-	Read/Write	No
AXIS2.SAFEPARAM.SLP_3.TIMEDELAYMONITORING	326eh	06h	Unsigned16	-	-	Read/Write	No

9.9.1.115 AXIS#.SAFEPARAM.SLS_#.DECLIMIT

Description

Indicates the deceleration limit of the deceleration monitoring of the Safely Limited Speed (SLS) safety function. This deceleration monitoring needs to be enabled in the safety parameters (see [AXIS#.SAFEPARAM.SLS_#.DECMONITOREN](#)). A value of zero means that the deceleration monitoring is disabled.

Context

For complete SLS information refer to "SLS (Safely Limited Speed)" (→ # 261).

Versions

Action	Version	Notes
Implemented	2-04-00-000	Implemented in SMM revision v0.56

General Information

Type	Read/Write
Units	Depends on user units
Range	0 or $[1, 2^{31}-1]$
Default Value	0 (Disabled)
Data Type	Integer
Stored in Non-Volatile Memory	No

9.9.1.116 AXIS#.SAFEPARAM.SLS_#.DECMONITOREN

Description

Indicates if the deceleration monitoring is enabled for the Safely Limited Speed (SLS) safety function.

Value	Description
0	Disabled (Default)
1	Enabled

Context

For complete SLS information refer to "SLS (Safely Limited Speed)" (→ # 261).

Versions

Action	Version	Notes
Implemented	2-04-00-000	Implemented in SMM revision v0.56

General Information

Type	Read/Write
Units	N/A
Range	0, 1
Default Value	0 (Disabled)
Data Type	Integer
Stored in Non-Volatile Memory	No

9.9.1.117 AXIS#.SAFEPARAM.SLS_#.FAULTREACTION

Description

Indicates the safety function activated when Safely Limited Speed (SLS) is faulted. One of the following values can be used:

Value	Description
1	STO
2	SS1 Instance 1
3	SS2 Instance 1

Context

For complete SLS information refer to "SLS (Safely Limited Speed)" (→ # 261).

Versions

Action	Version	Notes
Implemented	2-04-00-000	Implemented in SMM revision v0.56

General Information

Type	Read/Write
Units	N/A
Range	1, 2, 3
Default Value	1 (STO)
Data Type	Integer
Stored in Non-Volatile Memory	No

9.9.1.118 AXIS#.SAFEPARAM.SLS_#.FSOE

Description

Indicates if the Safely Limited Speed (SLS) function can be activated through FSoE. This parameter can only set to "Used" when FSoE is activated ([SAFEPARAM.SAFEFIELDDBUS.ACTIVATION](#) is set to 1 - "Activated").

Value	Description
0	Not used
1	Used

Context

For complete SLS information refer to "SLS (Safely Limited Speed)" (→ # 261).

Versions

Action	Version	Notes
Implemented	2-04-00-000	Implemented in SMM revision v0.56

General Information

Type	Read/Write
Units	N/A
Range	0, 1
Default Value	0 (Not used)
Data Type	Integer
Stored in Non-Volatile Memory	No

9.9.1.119 AXIS#.SAFEPARAM.SLS_#.FUNCTIONACTIVATION

Description

Indicates whether the Safely Limited Speed (SLS) safety function can be activated. One of the following values can be used:

Value	Description
0	Not active
1	Ready for activation
2	Always activated

This function can only be used when a safe encoder is configured in the safety parameters.

Context

For complete SLS information refer to "SLS (Safely Limited Speed)" (→ # 261).

Versions

Action	Version	Notes
Implemented	2-04-00-000	Implemented in SMM revision v0.56

General Information

Type	Read/Write
Units	N/A
Range	0, 1, 2
Default Value	0 (Never active)
Data Type	Integer
Stored in Non-Volatile Memory	No

9.9.1.120 AXIS#.SAFEPARAM.SLS_#.SAFEINPUT

Description

Indicates which safe input can trigger the Safely Limited Speed (SLS) safety function.

Value	Description
0	Not used
1	Safe Input 1 (SIN1)
2	Safe Input 2 (SIN2)
3	Safe Input 3 (SIN3)
4	Safe Input 4 (SIN4)
5	Safe dual input 1 (SIN1/SIN2)
6	Safe dual input 2 (SIN3/SIN4)

Context

For complete SLS information refer to "SLS (Safely Limited Speed)" (→ # 261).

Versions

Action	Version	Notes
Implemented	2-04-00-000	Implemented in SMM revision v0.56

General Information

Type	Read/Write
Units	N/A
Range	0, 1, 2, 3, 4, 5, 6
Default Value	0 (Not used)
Data Type	Integer
Stored in Non-Volatile Memory	No

9.9.1.121 AXIS#.SAFEPARAM.SLS_#.TIMEDELAYDECMONITORING

Description

Indicates the delay before starting the deceleration monitoring. The delay starts elapsing when Safely Limited Speed (SLS) is activated. When it finally elapses, the monitoring is started. This parameter can only be used when the deceleration monitoring is enabled in the safety parameters (see [AXIS#.SAFEPARAM.SLS_#.DECMONITOREN](#)).

Context

For complete SLS information refer to "SLS (Safely Limited Speed)" (→ # 261).

Versions

Action	Version	Notes
Implemented	2-04-00-000	Implemented in SMM revision v0.56

General Information

Type	Read/Write
Units	Milliseconds
Range	[1, 60000]
Default Value	1
Data Type	Integer
Stored in Non-Volatile Memory	No

9.9.1.122 AXIS#.SAFEPARAM.SLS_#.TIMEFORVELINLIMITS

Description

Indicates the time for the velocity in limits for the Safely Limited Speed (SLS) safety function. After this time, the monitoring can be activated if the velocity is already in the limits. This is the time the velocity has to be within the limits before the final state is activated.

Context

For complete SLS information refer to "SLS (Safely Limited Speed)" (→ # 261).

Versions

Action	Version	Notes
Implemented	2-04-00-000	Implemented in SMM revision v0.56

General Information

Type	Read/Write
Units	Milliseconds
Range	[1, 60000]
Default Value	1
Data Type	Integer
Stored in Non-Volatile Memory	No

9.9.1.123 AXIS#.SAFEPARAM.SLS_#.TIMETOVELMONITORING**Description**

Indicates the maximum time before starting the velocity monitoring of the Safely Limited Speed (SLS) safety function. If the velocity is not below the limit when this time elapsed then the function is faulted and it activates the configured fault reaction.

Context

For complete SLS information refer to "SLS (Safely Limited Speed)" (→ # 261).

Versions

Action	Version	Notes
Implemented	2-04-00-000	Implemented in SMM revision v0.56

General Information

Type	Read/Write
Units	Milliseconds
Range	[2, 60000]
Default Value	2
Data Type	Integer
Stored in Non-Volatile Memory	No

9.9.1.124 AXIS#.SAFEPARAM.SLS_#.VELLIMIT

Description

Indicates the velocity limit of the Safely Limited Speed (SLS) safety function.

Context

For complete SLS information refer to "SLS (Safely Limited Speed)" (→ # 261).

Versions

Action	Version	Notes
Implemented	2-04-00-000	Implemented in SMM revision v0.56

General Information

Type	Read/Write
Units	Depends on user units
Range	[1, 2 ³¹ -1]
Default Value	1
Data Type	Integer
Stored in Non-Volatile Memory	No

9.9.1.125 AXIS#.SAFEPARAM.SOS_x.FSOE

Description

Indicates if the Safe Operating Stop (SOS) function can be activated through FSoE. This parameter can only set to "Used" when FSoE is activated ([SAFEPARAM.SAFEFIELDDBUS.ACTIVATION](#) is set to 1 - "Activated").

Value	Description
0	Not used
1	Used

Context

For complete SOS information refer to SOS (Safe Operating Stop).

Versions

Action	Version	Notes
Implemented	2-04-00-000	Implemented in SMM revision v0.54

General Information

Type	Read/Write
Units	N/A
Range	0, 1
Default Value	0 (Not used)
Data Type	Integer

Stored in Non Volatile Memory	No
-------------------------------	----

9.9.1.126 AXIS#.SAFEPARAM.SOS_x.FUNCTIONACTIVATION

Description

Indicates if the SOS function can be activated. One of the following values can be used:

Value	Description
0	Never active
1	Ready for activation

This function can only be used when a safe encoder is configured in the safety parameters.

Context

For complete SOS information refer to SOS (Safe Operating Stop).

Versions

Action	Version	Notes
Implemented	2-04-00-000	Implemented in SMM revision v0.54

General Information

Type	Read/Write
Units	N/A
Range	0, 1
Default Value	0 (Never active)
Data Type	Integer
Stored in Non-Volatile Memory	No

9.9.1.127 AXIS#.SAFEPARAM.SOS_x.POSZEROWINDOW

Description

Indicates the Safe Operating Stop (SOS) position window.

Context

For complete SOS information refer to SOS (Safe Operating Stop).

Versions

Action	Version	Notes
Implemented	2-04-00-000	Implemented in SMM revision v0.54

General Information

Type	Read/Write
------	------------

Units	Depends on user units
Range	[0, 2 ³¹ -1]
Default Value	1
Data Type	Integer
Stored in Non-Volatile Memory	No

Fieldbus Information

EtherCAT CoE and CANopen

Command	Index	SubIndex	Data Type	Units	Float Scale	Access	PDO Mappable
AXIS1.SAFEPARAM.SOS_1.POSZEROWINDOW	315bh	07h	Unsigned32	-	-	Read/Write	No
AXIS1.SAFEPARAM.SOS_2.POSZEROWINDOW	3172h	07h	Unsigned32	-	-	Read/Write	No
AXIS2.SAFEPARAM.SOS_1.POSZEROWINDOW	325bh	07h	Unsigned32	-	-	Read/Write	No
AXIS2.SAFEPARAM.SOS_2.POSZEROWINDOW	3272h	07h	Unsigned32	-	-	Read/Write	No

9.9.1.128 AXIS#.SAFEPARAM.SOS_x.RESTARTACKBEHAVIOR

Description

Indicates whether the Safe Operating Stop (SOS) automatically resets or requires a manual reset using safe input or FSoE. In Automatic Restart mode, when the SOS input clears, the SOS automatically restarts (i.e., the function is cleared). In Manual Restart mode, when the SOS input clears, the SOS function remains active until the configured input triggers the SOS to restart. (See [AXIS#.SAFEPARAM.SOS_x.RESTARTACKSOURCE](#)).

Value	Description
0	Automatic restart (Default)
1	Manual restart

Context

For complete SOS information refer to SOS (Safe Operating Stop).

Versions

Action	Version	Notes
Implemented	2-04-00-000	Implemented in SMM revision v0.56

General Information

Type	Read/Write
Units	N/A
Range	0, 1
Default Value	0 (Automatic restart)
Data Type	Integer
Stored in Non-Volatile Memory	No

9.9.1.129 AXIS#.SAFEPARAM.SOS_x.RESTARTACKSOURCE

Description

Indicates the input to use to manually clear the Safe Operating Stop (SOS) function. Only used when the SOS is configured for Manual Restart mode (see [AXIS#.SAFEPARAM.SOS_x.RESTARTACKBEHAVIOR](#)).

Value	Description
0	Not Used (Default)
1	Safe Input 1 (SIN1)
2	Safe Input 2 (SIN2)
3	Safe Input 3 (SIN3)
4	Safe Input 4 (SIN4)
5	Safe Dual Input 1 (SIN1/SIN2)
6	Safe Dual Input 2 (SIN3/SIN4)

Context

For complete SOS information refer to SOS (Safe Operating Stop).

Versions

Action	Version	Notes
Implemented	2-04-00-000	Implemented in SMM revision v0.54

General Information

Type	Read/Write
Units	N/A
Range	0, 1, 2, 3, 4, 5, 6
Default Value	0 (Not used)
Data Type	Integer
Stored in Non-Volatile Memory	No

9.9.1.130 AXIS#.SAFEPARAM.SOS_x.SAFEINPUT

Description

Indicates which safe input triggers the Safe Operating Stop (SOS) safety function.

Value	Description
0	Not used
1	Safe Input 1 (SIN1)
2	Safe Input 2 (SIN2)
3	Safe Input 3 (SIN3)
4	Safe Input 4 (SIN4)
5	Safe dual input 1 (SIN1/SIN2)
6	Safe dual input 2 (SIN3/SIN4)

Context

For complete SOS information refer to SOS (Safe Operating Stop).

Versions

Action	Version	Notes
Implemented	2-04-00-000	Implemented in SMM revision v0.54

General Information

Type	Read/Write
Units	N/A
Range	0, 1, 2, 3, 4, 5, 6
Default Value	0 (Not used)
Data Type	Integer
Stored in Non-Volatile Memory	No

9.9.1.131 AXIS#.SAFEPARAM.SOS_x.TIMEDELAYMONITORING

Description

Indicates the delay before Safe Operating Stop (SOS) starts monitoring.

Context

For complete SOS information refer to SOS (Safe Operating Stop).

Versions

Action	Version	Notes
Implemented	2-04-00-000	Implemented in SMM revision v0.56

General Information

Type	Read/Write
Units	Milliseconds
Range	[0, 60000]
Default Value	1
Data Type	Integer
Stored in Non-Volatile Memory	No

9.9.1.132 AXIS#.SAFEPARAM.SOS_x.VELMONITOREN

Description

Indicates if the velocity monitoring is enabled with the Safe Operating Stop (SOS) safety function.

Value	Description
0	Disabled (Default)
1	Enabled

Context

For complete SOS information refer to SOS (Safe Operating Stop).

Versions

Action	Version	Notes
Implemented	2-04-00-000	Implemented in SMM revision v0.56

General Information

Type	Read/Write
Units	N/A
Range	0, 1
Default Value	0 (Disabled)
Data Type	Integer
Stored in Non-Volatile Memory	No

9.9.1.133 AXIS#.SAFEPARAM.SOS_x.VELZEROWINDOW

Description

Indicates the Safe Operating Stop (SOS) velocity window. It is only in use when the velocity monitoring is enabled (see [AXIS#.SAFEPARAM.SOS_x.VELMONITOREN](#)). A value of zero means that the velocity monitoring is disabled.

Context

For complete SOS information refer to SOS (Safe Operating Stop).

Versions

Action	Version	Notes
Implemented	2-04-00-000	Implemented in SMM revision v0.56

General Information

Type	Read/Write
Units	Depends on user units
Range	[0, 2 ³¹ -1]
Default Value	0 (Monitoring disabled)
Data Type	Integer
Stored in Non-Volatile Memory	No

9.9.1.134 AXIS#.SAFEPARAM.SPEEDCOMPUTATIONINTERVAL

Description

Indicates the time interval used to compute the speed in the SMM. This is only applicable when a safe encoder has been configured in the safety parameters.

Context

For safe encoder details refer to "Motor feedback requirements" (→ # 216).

Versions

Action	Version	Notes
Implemented	2-04-00-000	Implemented in SMM revision v0.56

General Information

Type	Read/Write
Units	Milliseconds
Range	[1, 100]
Default Value	1
Data Type	Integer
Stored in Non-Volatile Memory	No

Fieldbus Information

EtherCAT CoE and CANopen

Command	Index	SubIndex	Data Type	Units	Float Scale	Access	PDO Mappable
AXIS1.SAFEPARAM.SPEEDCOMPUTATIONINTERVAL	3150h	02h	Unsigned 8	-	-	Read/Write	No
AXIS2.SAFEPARAM.SPEEDCOMPUTATIONINTERVAL	3250h	02h	Unsigned 8	-	-	Read/Write	No

9.9.1.135 AXIS#.SAFEPARAM.SS1_#.DECLIMIT

Description

Indicates the deceleration limit for Safe Stop 1 (SS1). A value of zero means the deceleration monitoring is disabled. This can only be used when a safe encoder is configured in the safety parameters and speed/acceleration monitoring is enabled in the safety parameters (see [AXIS#.SAFEPARAM.SS1_#.VELDECMONITOREN](#)).

Context

For complete SS1 information refer to (→ # 223) / (→ # 228).

Versions

Action	Version	Notes
Implemented	2-04-00-000	Implemented in SMM revision v0.54

General Information

Type	Read/Write
Units	Acceleration in defined user units
Range	[0, 2 ³¹ -1]
Default Value	0 (Deceleration monitoring disabled)
Data Type	Integer
Stored in Non-Volatile Memory	No

9.9.1.136 AXIS#.SAFEPARAM.SS1_#.FSOE

Description

Indicates if the Safe Stop 1 (SS1) function instance can be activated through FSoE. This parameter can only be set to “Used” when FSoE is activated ([SAFEPARAM.SAFEFIELDDBUS.ACTIVATION](#) is set to 1 - “Activated”).

Value	Description
0	Not used
1	Used

Context

For complete SS1 information refer to (→ # 223) / (→ # 228).

Versions

Action	Version	Notes
Implemented	2-00-00-000	Implemented in SMM revision v0.54

General Information

Type	Read/Write
Units	N/A
Range	0, 1
Default Value	0 (Not used)
Data Type	Integer
Stored in Non-Volatile Memory	No

9.9.1.137 AXIS#.SAFEPARAM.SS1_#.FUNCTIONACTIVATION**Description**

Indicates how the function can be activated.

Safe Stop 1 (SS1) Instance 1 is always ready for activation (fault reaction).

SS1 Instance 2 and SS1 Instance 3 can be set to one of the two following values:

Value	Description
0	Never active
1	Ready for activation

Context

For complete SS1 information refer to (→ # 223) or (→ # 228).

Versions

Action	Version	Notes
Implemented	2-00-00-000	Implemented in SMM revision v0.54

General Information

Type	Read/Write
Units	N/A
Range	1 for Instance 1 0, 1 for Instance 2 or 3
Default Value	Instance 1 : 1 (Ready for activation) Instance 2 and 3 : 0 (Never active)
Data Type	Integer
Stored in Non-Volatile Memory	No

9.9.1.138 AXIS#.SAFEPARAM.SS1_#.SAFEINPUT

Description

Indicates which safe input can trigger the Safe Stop 1 (SS1) safety function.

Value	Description
0	Not used
1	Safe Input 1 (SIN1)
2	Safe Input 2 (SIN2)
3	Safe Input 3 (SIN3)
4	Safe Input 4 (SIN4)
5	Safe dual input 1 (SIN1/SIN2)
6	Safe dual input 2 (SIN3/SIN4)

Context

For complete SS1 information refer to (→ # 223) / (→ # 228).

Versions

Action	Version	Notes
Implemented	2-00-00-000	Implemented in SMM revision v0.54

General Information

Type	Read/Write
Units	N/A
Range	0, 1, 2, 3, 4, 5, 6
Default Value	0 (Not used)
Data Type	Integer
Stored in Non-Volatile Memory	No

9.9.1.139 AXIS#.SAFEPARAM.SS1_#.TIMEDELAYDECMONITORING

Description

Indicates the time delay before starting the deceleration monitoring. The timer starts when Safe Stop 1 (SS1) is activated. The monitoring of the deceleration starts when it elapses. This can only be used when a safe encoder is configured in the safety parameters and speed/acceleration monitoring is enabled in the safety parameters (see [AXIS#.SAFEPARAM.SS1_#.VELDECMONITOREN](#)).

Context

For complete SS1 information refer to (→ # 223) / (→ # 228).

Versions

Action	Version	Notes
Implemented	2-04-00-000	Implemented in SMM revision v0.54

General Information

Type	Read/Write
Units	Milliseconds
Range	[1, 60000]
Default Value	1
Data Type	Integer
Stored in Non-Volatile Memory	No

9.9.1.140 AXIS#.SAFEPARAM.SS1_#.TIMEFORVELZERO

Description

Indicates the time for the zero velocity. This can only be used when a safe encoder is configured in the safety parameters and speed/acceleration monitoring is enabled in the safety parameters (see [AXIS#.SAFEPARAM.SS1_#.VELDECMONITOREN](#)).

Context

For complete SS1 information refer to (→ # 223) / (→ # 228).

Versions

Action	Version	Notes
Implemented	2-04-00-000	Implemented in SMM revision v0.54

General Information

Type	Read/Write
Units	Milliseconds
Range	[1, 60000]
Default Value	1
Data Type	Integer
Stored in Non-Volatile Memory	No

9.9.1.141 AXIS#.SAFEPARAM.SS1_#.TIMETOSTO

Description

Indicates the maximum time delay in milliseconds to initiate Safe Torque Off (STO) when SS1 is activated.

Context

For complete SS1 information refer to (→ # 223) / (→ # 228).

Versions

Action	Version	Notes
Implemented	02-00-00-000	Implemented in SMM revision v0.54

General Information

Type	Read/Write
Units	Milliseconds
Range	[2, 60000]
Default Value	2
Data Type	Integer
Stored in Non-Volatile Memory	No

9.9.1.142 AXIS#.SAFEPARAM.SS1_#.VELDECMONITOREN

Description

Indicates if the velocity and deceleration monitoring is enabled for this Safe Stop 1 (SS1) instance. Velocity and deceleration monitoring can only be enabled if a safe encoder is configured in the safety parameter. When the velocity and deceleration monitoring is disabled (default value), SS1 is time based (SS1-t).

Value	Description
0	Disabled (Default)
1	Enabled

Context

For complete SS1 information refer to (→ # 223) / (→ # 228).

Versions

Action	Version	Notes
Implemented	2-04-00-000	Implemented in SMM revision v0.56

General Information

Type	Read/Write
Units	N/A
Range	0, 1
Default Value	0 (Disabled)
Data Type	Integer
Stored in Non-Volatile Memory	No

9.9.1.143 AXIS#.SAFEPARAM.SS1_#.VELZEROWINDOW

Description

Indicates the velocity zero window for Safe Stop 1 (SS1). When SS1 is active and the velocity is inside the velocity zero window, the Safe Torque Off (STO) function is activated. If configured, the Safe Brake Control (SBC) function is also activated. This can only be used when a safe encoder is configured in the safety parameters and speed/acceleration monitoring is enabled in the safety parameters (see [SAFEPARAM.SS1_#.VELDECMONITOREN](#)).

Context

For complete SS1 information refer to (→ # 223) / (→ # 228).

Versions

Action	Version	Notes
Implemented	2-04-00-000	Implemented in SMM revision v0.56

General Information

Type	Read/Write
Units	Speed in defined user units
Range	[1, 2 ³¹ -1]
Default Value	1
Data Type	Integer
Stored in Non-Volatile Memory	No

9.9.1.144 AXIS#.SAFEPARAM.SS2_#.DECLIMIT

Description

Indicates the deceleration limit for Safe Stop 2 (SS2). A value of zero means that the deceleration monitoring is disabled. This can only be used when a safe encoder is configured in the safety parameters (see [AXIS#.SAFE.SS2_#.DECMONITOREN](#)).

Context

For complete SS2 information refer to "SS2 (Safe Stop 2)" (→ # 232).

Versions

Action	Version	Notes
Implemented	2-04-00-000	Implemented in SMM revision v0.54

General Information

Type	Read/Write
Units	Acceleration in defined user units
Range	[0, 2 ³¹ -1]
Default Value	0 (Deceleration monitoring disabled)
Data Type	Integer
Stored in Non-Volatile Memory	No

9.9.1.145 AXIS#.SAFEPARAM.SS2_#.DECMONITOREN**Description**

Indicates if the deceleration monitoring is enabled for this Safe Stop 2 (SS2) instance.

Value	Description
0	Disabled (Default)
1	Enabled

Context

For complete SS2 information refer to "SS2 (Safe Stop 2)" (→ # 232).

Versions

Action	Version	Notes
Implemented	2-04-00-000	Implemented in SMM revision v0.54

General Information

Type	Read/Write
Units	N/A
Range	0, 1
Default Value	0 (Disabled)
Data Type	Integer
Stored in Non-Volatile Memory	No

9.9.1.146 AXIS#.SAFEPARAM.SS2_#.FAULTREACTION

Description

Indicates the safety function activated when Safe Stop 2 (SS2) fails to execute correctly. This happens for different reasons such as if the deceleration monitoring detects that the axis does not ramp down as expected. The parameter allows one of the following values:

Value	Description
1	STO
2	SS1 Instance 1

Context

For complete SS2 information refer to "SS2 (Safe Stop 2)" (→ # 232).

Versions

Action	Version	Notes
Implemented	2-04-00-000	Implemented in SMM revision v0.54

General Information

Type	Read/Write
Units	N/A
Range	1, 2
Default Value	1 (STO)
Data Type	Integer
Stored in Non-Volatile Memory	No

9.9.1.147 AXIS#.SAFEPARAM.SS2_#.FSOE

Description

Indicates if the Safe Stop 2 (SS2) function can be activated through FSoE. This parameter can only set to “Used” when FSoE is activated ([SAFEPARAM.SAFEFIELDBUS.ACTIVATION](#) is set to 1 - “Activated”).

Value	Description
0	Not used
1	Used

Context

For complete SS2 information refer to "SS2 (Safe Stop 2)" (→ # 232).

Versions

Action	Version	Notes
Implemented	2-04-00-000	Implemented in SMM revision v0.54

General Information

Type	Read/Write
Units	N/A
Range	0, 1
Default Value	0 (Not used)
Data Type	Integer
Stored in Non-Volatile Memory	No

9.9.1.148 AXIS#.SAFEPARAM.SS2_#.FUNCTIONACTIVATION

Description

Indicates how the SS2 function can be activated. The parameter allows one of the following values:

Value	Description
10	Never active
1	Ready for activation

Context

For complete SS2 information refer to "SS2 (Safe Stop 2)" (→ # 232).

Versions

Action	Version	Notes
Implemented	2-04-00-000	Implemented in SMM revision v0.54

General Information

Type	Read/Write
Units	N/A
Range	0, 1
Default Value	0 (Never active)
Data Type	Integer
Stored in Non-Volatile Memory	No

9.9.1.149 AXIS#.SAFEPARAM.SS2_#.SAFEINPUT

Description

Indicates which safe input can trigger the Safe Stop 2 (SS2) safety function.

Value	Description
0	Not used
1	Safe Input 1 (SIN1)
2	Safe Input 2 (SIN2)
3	Safe Input 3 (SIN3)
4	Safe Input 4 (SIN4)
5	Safe dual input 1 (SIN1/SIN2)
6	Safe dual input 2 (SIN3/SIN4)

Context

For complete SS2 information refer to "SS2 (Safe Stop 2)" (→ # 232).

Versions

Action	Version	Notes
Implemented	2-04-00-000	Implemented in SMMrevision v0.56

General Information

Type	Read/Write
Units	N/A
Range	0, 1, 2, 3, 4, 5, 6
Default Value	0 (Not used)
Data Type	Integer
Stored in Non-Volatile Memory	No

9.9.1.150 AXIS#.SAFEPARAM.SS2_#.TIMEDELAYDECMONITORING

Description

Indicates the delay before starting the deceleration monitoring. The delay starts elapsing when Safe Stop 2 (SS2) is activated. When it elapses, the monitoring is started. This parameter can only be used when the deceleration monitoring is enabled in the safety parameters (see [AXIS#.SAFEPARAM.SS2_#.DECMONITOREN](#)).

Context

For complete SS2 information refer to "SS2 (Safe Stop 2)" (→ # 232).

Versions

Action	Version	Notes
Implemented	2-04-00-000	Implemented in SMM revision v0.54

General Information

Type	Read/Write
Units	Milliseconds
Range	[1, 60000]
Default Value	1
Data Type	Integer
Stored in Non-Volatile Memory	No

9.9.1.151 AXIS#.SAFEPARAM.SS2_#.TIMEFORVELZERO**Description**

Indicates the time for zero velocity.

Context

For complete SS2 information refer to "SS2 (Safe Stop 2)" (→ # 232).

Versions

Action	Version	Notes
Implemented	2-04-00-000	Implemented in SMM revision v0.54

General Information

Type	Read/Write
Units	Milliseconds
Range	[1, 60000]
Default Value	1
Data Type	Integer
Stored in Non-Volatile Memory	No

9.9.1.152 AXIS#.SAFEPARAM.SS2_#.TIMETOSOS

Description

Indicates the maximum time delay in milliseconds to initiate Safe Operating Stop (SOS) when Safe Stop 2 (SS2) is activated.

Context

For complete SS2 information refer to "SS2 (Safe Stop 2)" (→ # 232).

Versions

Action	Version	Notes
Implemented	2-04-00-000	Implemented in SMM revision v0.54

General Information

Type	Read/Write
Units	Milliseconds
Range	[2, 60000]
Default Value	2
Data Type	Integer
Stored in Non-Volatile Memory	No

9.9.1.153 AXIS#.SAFEPARAM.SSM_#.FUNCTIONACTIVATION

Description

Indicates the velocity upper limit of the Safe Speed Monitor (SSM) safety function. The parameter allows one of the following values:

Value	Description
0	Never active
2	Always activated

This function can only be used when a safe encoder is configured in the safety parameters.

Context

For complete SSM information refer to "SSM (Safe Speed Monitor)" (→ # 264).

Versions

Action	Version	Notes
Implemented	2-04-00-000	Implemented in SMM revision v0.56

General Information

Type	Read/Write
Units	N/A
Range	0, 2
Default Value	0 (Never active)
Data Type	Integer
Stored in Non-Volatile Memory	No

9.9.1.154 AXIS#.SAFEPARAM.SSM_#.VELLOWERLIMIT

Description

Indicates the velocity lower limit of the Safe Speed Monitor (SSM) safety function.

Context

For complete SSM information refer to "SSM (Safe Speed Monitor)" (→ # 264).

Versions

Action	Version	Notes
Implemented	2-04-00-000	Implemented in SMM revision v0.56

General Information

Type	Read/Write
Units	Depends on user units
Range	$[-2^{31}+1, 2^{31}-1]$
Default Value	0
Data Type	Integer
Stored in Non-Volatile Memory	No

9.9.1.155 AXIS#.SAFEPARAM.SSM_#.VELUPPERLIMIT**Description**

Indicates the velocity upper limit of the Safe Speed Monitor (SSM) function.

Context

For complete SSM information refer to "SSM (Safe Speed Monitor)" (→ # 264).

Versions

Action	Version	Notes
Implemented	2-04-00-000	Implemented in SMM revision v0.56

General Information

Type	Read/Write
Units	Depends on user units
Range	$[-2^{31}+1, 2^{31}-1]$
Default Value	0
Data Type	Integer
Stored in Non-Volatile Memory	No

9.9.1.156 AXIS#.SAFEPARAM.SSR_#.DECLIMIT

Description

Indicates the deceleration limit of the deceleration monitoring of the Safe Speed Range (SSR) safety function. The deceleration monitoring needs to be enabled in the safety parameters (see [AXIS#.SAFEPARAM.SSR_#.DECMONITOREN](#)). A value of zero means the deceleration monitoring is disabled.

Context

For complete SSR information refer to "SSR (Safe Speed Range)" (→ # 266).

Versions

Action	Version	Notes
Implemented	2-04-00-000	Implemented in SMM revision v0.56

General Information

Type	Read/Write
Units	Depends on user units
Range	0 or [1, 2 ³¹ -1]
Default Value	0 (Disabled)
Data Type	Integer
Stored in Non-Volatile Memory	No

9.9.1.157 AXIS#.SAFEPARAM.SSR_#.DECMONITOREN**Description**

Indicates if the deceleration monitoring is enabled for the Safe Speed Range (SSR) safety function.

Value	Description
0	Disabled (Default)
1	Enabled

Context

For complete SSR information refer to "SSR (Safe Speed Range)" (→ # 266).

Versions

Action	Version	Notes
Implemented	2-04-00-000	Implemented in SMM revision v0.56

General Information

Type	Read/Write
Units	N/A
Range	0, 1
Default Value	0 (Disabled)
Data Type	Integer
Stored in Non-Volatile Memory	No

9.9.1.158 AXIS#.SAFEPARAM.SSR_#.FAULTREACTION

Description

Indicates the safety function activated when Safe Speed Range (SSR) is faulted. The parameter allows one of the following values:

Value	Description
1	STO
2	SS1 Instance 1
3	SS2 Instance 1

Context

For complete SSR information refer to "SSR (Safe Speed Range)" (→ # 266).

Versions

Action	Version	Notes
Implemented	2-04-00-000	Implemented in SMM revision v0.56

General Information

Type	Read/Write
Units	N/A
Range	1, 2, 3
Default Value	1 (STO)
Data Type	Integer
Stored in Non-Volatile Memory	No

9.9.1.159 AXIS#.SAFEPARAM.SSR_#.FSOE**Description**

Indicates if the Safe Speed Range (SSR) function can be activated through FSoE. This parameter can only be set to "Used" when FSoE is activated ("SAFEPARAM.SAFEFIELDDBUS.ACTIVATION" (→ # 534) is set to 1 - "Activated").

Value	Description
0	Not used
1	Used

Context

For complete SSR information refer to "SSR (Safe Speed Range)" (→ # 266).

Versions

Action	Version	Notes
Implemented	2-04-00-000	Implemented in SMM revision v0.56

General Information

Type	Read/Write
Units	N/A
Range	0, 1
Default Value	0 (Not used)
Data Type	Integer
Stored in Non-Volatile Memory	No

9.9.1.160 AXIS#.SAFEPARAM.SSR_#.FUNCTIONACTIVATION

Description

Indicates whether the Safe Speed Range (SSR) safety function can be activated. The parameter allows one of the following values:

Value	Description
0	Never active
1	Ready for activation

This function can only be used when a safe encoder is configured in the safety parameters.

Context

For complete SSR information refer to "SSR (Safe Speed Range)" (→ # 266).

Versions

Action	Version	Notes
Implemented	2-04-00-000	Implemented in SMM revision v0.56

General Information

Type	Read/Write
Units	N/A
Range	0, 1
Default Value	0 (Never active)
Data Type	Integer
Stored in Non-Volatile Memory	No

9.9.1.161 AXIS#.SAFEPARAM.SSR_#.SAFEINPUT

Description

Indicates which safe input can trigger the Safe Speed Range (SSR) safety function.

Value	Description
0	Not used
1	Safe Input 1 (SIN1)
2	Safe Input 2 (SIN2)
3	Safe Input 3 (SIN3)
4	Safe Input 4 (SIN4)
5	Safe dual input 1 (SIN1/SIN2)
6	Safe dual input 2 (SIN3/SIN4)

Context

For complete SSR information refer to "SSR (Safe Speed Range)" (→ # 266).

Versions

Action	Version	Notes
Implemented	2-04-00-000	Implemented in SMM revision v0.56

General Information

Type	Read/Write
Units	N/A
Range	0, 1, 2, 3, 4, 5, 6
Default Value	0 (Not used)
Data Type	Integer
Stored in Non-Volatile Memory	No

9.9.1.162 AXIS#.SAFEPARAM.SSR_#.TIMEDELAYDECMONITORING

Description

Indicates the delay before starting the deceleration monitoring. The delay starts elapsing when Safe Speed Range (SSR) is activated. When it finally elapses, the monitoring is started. This parameter can only be used when the deceleration monitoring is enabled in the safety parameters (see "AXIS#.SAFEPARAM.SSR_#.DECMONITOREN" (→ # 480)).

Context

For complete SSR information refer to "SSR (Safe Speed Range)" (→ # 266).

Versions

Action	Version	Notes
Implemented	2-04-00-000	Implemented in SMM revision v0.56

General Information

Type	Read/Write
Units	Milliseconds
Range	[1, 60000]
Default Value	1
Data Type	Integer
Stored in Non-Volatile Memory	No

9.9.1.163 AXIS#.SAFEPARAM.SSR_#.TIMEFORVELINLIMITS**Description**

Indicates the time for the velocity in limits for the Safe Speed Range (SSR) safety function. After this time, the monitoring can be activated if the velocity is already in the limits.

Context

For complete SSR information refer to "SSR (Safe Speed Range)" (→ # 266).

Versions

Action	Version	Notes
Implemented	2-04-00-000	Implemented in SMM revision v0.56

General Information

Type	Read/Write
Units	Milliseconds
Range	[1, 60000]
Default Value	1
Data Type	Integer
Stored in Non-Volatile Memory	No

9.9.1.164 AXIS#.SAFEPARAM.SSR_#.TIMETOVELMONITORING**Description**

Indicates the maximum time to start the velocity monitoring for the Safe Speed Range (SSR) safety function. If the velocity is still not in range after this time, the function will be faulted and activates its configured fault reaction

Context

For complete SSR information refer to "SSR (Safe Speed Range)" (→ # 266).

Versions

Action	Version	Notes
Implemented	2-04-00-000	Implemented in SMM revision v0.56

General Information

Type	Read/Write
Units	Milliseconds
Range	[1, 60000]
Default Value	2
Data Type	Integer
Stored in Non-Volatile Memory	No

9.9.1.165 AXIS#.SAFEPARAM.SSR_#.VELLOWERLIMIT**Description**

Indicates the velocity lower limit of the Safe Speed Range (SSR) safety function.

Context

For complete SSR information refer to "SSR (Safe Speed Range)" (→ # 266).

Versions

Action	Version	Notes
Implemented	2-04-00-000	Implemented in SMM revision v0.56

General Information

Type	Read/Write
Units	Depends on user units
Range	$[-2^{31}+1, 2^{31}-1]$
Default Value	0
Data Type	Integer
Stored in Non-Volatile Memory	No

9.9.1.166 AXIS#.SAFEPARAM.SSR_#.VELUPPERLIMIT

Description

Indicates the velocity upper limit of the Safe Speed Range (SSR) safety function.

Context

For complete SSR information refer to "SSR (Safe Speed Range)" (→ # 266).

Versions

Action	Version	Notes
Implemented	2-04-00-000	Implemented in SMM revision v0.56

General Information

Type	Read/Write
Units	Depends on user units
Range	$[-2^{31}+1, 2^{31}-1]$
Default Value	0
Data Type	Integer
Stored in Non-Volatile Memory	No

9.9.1.167 AXIS#.SAFEPARAM.STO.FSOE

Description

Indicates if the Safe Torque Off (STO) function can be activated through FSoE. This parameter can only be set to "Used" when FSoE is activated ([SAFEPARAM.SAFEFIELDDBUS.ACTIVATION](#) is set to 1 - "Activated").

Value	Description
0	Not used
1	Used

Context

For complete STO information refer to "STO (Safe Torque Off)" (→ # 219).

Versions

Action	Version	Notes
Implemented	02-00-00-000	Implemented in SMM revision v0.54

General Information

Type	Read/Write
Units	N/A
Range	0, 1
Default Value	Default (WorkBench): 0 (Not Activated) Default (FSoE): 1 (Activated)
Data Type	Integer
Stored in Non-Volatile Memory	No

9.9.1.168 AXIS#.SAFEPARAM.STO.FUNCTIONACTIVATION

Description

Indicates how the function can be activated. For Safe Torque Off (STO), the function is ready for activation.

Value	Description
1	Ready for activation

Context

For complete STO information refer to "STO (Safe Torque Off)" (→ # 219).

Versions

Action	Version	Notes
Implemented	02-00-00-000	Implemented in SMM revision v0.54

General Information

Type	Read/Write
Units	N/A
Range	1
Default Value	Axis 1 – 1 (Ready for activation) Axis 2 – 1 (Ready for activation)
Data Type	Integer
Stored in Non-Volatile Memory	No

Fieldbus Information

EtherCAT CoE and CANopen

Command	Index	SubIndex	Data Type	Units	Float Scale	Access	PDO Mappable
AXIS1.SAFEPARAM.STO.FUNCTIONACTIVATION	3152h	01h	Unsigned 8	-	-	Read/Write	No
AXIS2.SAFEPARAM.STO.FUNCTIONACTIVATION	3252h	01h	Unsigned 8	-	-	Read/Write	No

9.9.1.169 AXIS#.SAFEPARAM.STO.RESTARTACKMODE**Description**

Indicates whether the Safe Torque Off (STO) will automatically reset or requires a manual reset using safe input or FSoE. In Automatic Restart mode, when the STO input clears, the STO automatically restarts and the drive is enabled. In Manual Restart mode, when the STO input clears, the STO remains active until the configured input triggers the STO to restart. See 9.9.1.170 "AXIS#.SAFEPARAM.STO.RESTARTACKSOURCE").

Value	Description
0	Automatic Restart (default)
1	Manual Restart

Context

For complete STO information refer to "STO (Safe Torque Off)" (→ # 219).

Versions

Action	Version	Notes
Implemented	02-01-02-000	

General Information

Type	Read/Write
Units	N/A
Range	0 (Automatic Restart) 1 (Manual Restart)
Default Value	0 (Automatic Restart)
Data Type	Integer
Stored in Non-Volatile Memory	No

9.9.1.170 AXIS#.SAFEPARAM.STO.RESTARTACKSOURCE

Description

Indicates the input to use to manually clear the Safe Torque Off (STO) once the STO input is cleared. Only used when the STO is configured for Manual Restart mode (see 9.9.1.169 "AXIS#.SAFEPARAM.STO.RESTARTACKMODE").

Value	Description
0	Not Used
1	Safe Input 1
2	Safe Input 2
3	Safe Input 3
4	Safe Input 4
5	Safe dual input 1
6	Safe dual input 2

Context

For complete STO information refer to "STO (Safe Torque Off)" (→ # 219).

Versions

Action	Version	Notes
Implemented	02-01-02-000	

General Information

Type	Read/Write
Units	N/A
Range	0 or 6
Default Value	0 (Not used)
Data Type	Integer
Stored in Non-Volatile Memory	No

9.9.1.171 AXIS#.SAFEPARAM.STO.SAFEINPUT

Description

Indicates which safety input can trigger the Safe Torque Off (STO) safety function.

Value	Description
0	Not used
1	Safe Input 1 (SIN1)
2	Safe Input 2 (SIN2)
3	Safe Input 3 (SIN3)
4	Safe Input 4 (SIN4)
5	Safe dual input 1 (SIN1/SIN2)
6	Safe dual input 2 (SIN3/SIN4)

Context

For complete STO information refer to "STO (Safe Torque Off)" (→ # 219).

Versions

Action	Version	Notes
Implemented	02-00-00-000	Implemented in SMM revision v0.54

General Information

Type	Read/Write
Units	N/A
Range	0, 1, 2, 3, 4, 5, 6
Default Value	0 (not used)
Data type	Integer
Stored in Non-Volatile Memory	No

9.9.1.172 AXIS#.SAFEPARAM.UNIT.ACFFACTOR

Description

Indicates the acceleration factor unit.

Value	Description
0	nano
1	micro
2	milli
3	centi
4	deci
5	none
6	deca
7	hecto
8	kilo

Context

For details refer to "Parameterization of User Units" (→ # 304).

Versions

Action	Version	Notes
Implemented	2-04-00-000	Implemented in SMM revision v0.56

General Information

Type	Read/Write
Units	N/A
Range	0, 1, 2, 3, 4, 5, 6, 7, 8
Default Value	5 (None)
Data Type	Integer
Stored in Non-Volatile Memory	No

9.9.1.173 AXIS#.SAFEPARAM.UNIT.ACCINENC

Description

Indicates the acceleration increment in encoder units.

The safe system uses the following formula:

$$acceleration[counts/s^2] = acceleration * \frac{\langle accInEncUnit \rangle}{\langle accInUserUnit \rangle} * \frac{\langle resInNbInc \rangle}{\langle resInEncUnit \rangle}$$

With:

- *acclnEncUnit* is AXIS#.SAFEPARAM.UNIT.ACCINENC
- *acclnUserUnit* is AXIS#.SAFEPARAM.UNIT.ACCINUSER
- *resInNbInc*: the encoder resolution in counts
- *resInEncUnit*: resolution in encoder units

Example

- *acclnEncUnit* is AXIS#.SAFEPARAM.UNIT.ACCINENC
- *acclnUserUnit* is AXIS#.SAFEPARAM.UNIT.ACCINUSER

```

Acceleration: accInUserUnit[accUserUnit] = accInEncUnit[encUnit/s^2]
Acceleration: 60[rpm/s]=1[rev/s^2]
Acceleration: 1[mm/s^2]=1000000 [nm/s^2]
    
```

Context

For details refer to "Parameterization of User Units" (→ # 304).

Versions

Action	Version	Notes
Implemented	2-04-00-000	Implemented in SMM revision v0.56

General Information

Type	Read/Write
Units	User defined
Range	N/A
Default Value	1
Data Type	Integer
Stored in Non-Volatile Memory	No

9.9.1.174 AXIS#.SAFEPARAM.UNIT.ACCINUSER

Description

Indicates the acceleration increment in user units.

The safe system uses the following formula:

$$acceleration[counts/s^2] = acceleration * \frac{\langle accInEncUnit \rangle}{\langle accInUserUnit \rangle} * \frac{\langle resInNbInc \rangle}{\langle resInEncUnit \rangle}$$

With:

- *accInEncUnit* is AXIS#.SAFEPARAM.UNIT.ACCINENC
- *accInUserUnit* is AXIS#.SAFEPARAM.UNIT.ACCINUSER
- *resInNbInc*: the encoder resolution in counts
- *resInEncUnit*: resolution in encoder units

Example

- *accInEncUnit* is AXIS#.SAFEPARAM.UNIT.ACCINENC
- *accInUserUnit* is AXIS#.SAFEPARAM.UNIT.ACCINUSER

```
Acceleration: accInUserUnit[accUserUnit] = accInEncUnit[encUnit/s^2]
Acceleration: 60[rpm/s]=1[rev/s^2]
Acceleration: 1[mm/s^2]=1000000 [nm/s^2]
```

Context

For details refer to "Parameterization of User Units" (→ # 304).

Versions

Action	Version	Notes
Implemented	2-04-00-000	Implemented in SMM revision v0.56

General Information

Type	Read/Write
Units	User defined
Range	N/A
Default Value	60
Data Type	Integer
Stored in Non-Volatile Memory	No

9.9.1.175 AXIS#.SAFEPARAM.UNIT.ACCLABEL

Description

User unit label for acceleration values returned by the safety system. This parameter is only required for the parameter visualization in WorkBench or any other GUI. It is not used by the SMM software.

This is only applicable when a safe encoder has been defined in the safety parameters.

Value	Description
0	Counts/s ²
1	Degree/s ²
2	RPS/s
3	Radian/ ²
4	Arcminute/ ²
5	RPM/s
6	Meter/s ²
7	Inch/s ²

Context

For details refer to "Parameterization of User Units" (→ # 304).

Versions

Action	Version	Notes
Implemented	2-04-00-000	Implemented in SMM revision v0.56

General Information

Type	Read/Write
Units	N/A
Range	0, 1, 2, 3, 4, 5, 6, 7
Default Value	5 (RPM/s)
Data Type	Integer
Stored in Non-Volatile Memory	No

9.9.1.176 AXIS#.SAFEPARAM.UNIT.POSFACTOR

Description

Indicates the position factor unit.

Value	Description
0	nano
1	micro
2	milli
3	centi
4	deci
5	None
6	deca
7	hecto
8	kilo

Context

For details refer to "Parameterization of User Units" (→ # 304).

Versions

Action	Version	Notes
Implemented	2-04-00-000	Implemented in SMM revision v0.56

General Information

Type	Read/Write
Units	N/A
Range	0, 1, 2, 3, 4, 5, 6, 7, 8
Default Value	4 (deci)
Data Type	Integer
Stored in Non-Volatile Memory	No

9.9.1.177 AXIS#.SAFEPARAM.UNIT.POSINENC

Description

Indicates the position increment in encoder units.

The safe system uses the following formula:

$$Position[counts] = position * \frac{\langle posInEncUnit \rangle}{\langle posInUserUnit \rangle} * \frac{\langle resInNbInc \rangle}{\langle resInEncNbInc \rangle}$$

With:

- *posInEncUnit* is AXIS#.SAFEPARAM.UNIT.POSINENC
- *posInUserUnit* is AXIS#.SAFEPARAM.UNIT.POSINUSER
- *resInNbInc*: the encoder resolution in counts
- *resInEncUnit*: resolution in encoder units

Example

- *posInEncUnit* is AXIS#.SAFEPARAM.UNIT.POSINENC
- *posInUserUnit* is AXIS#.SAFEPARAM.UNIT.POSINUSER

```
Position: posInUserUnit[posUserUnit] = posInEncUnit[encUnit]
Position: 3600[deciDegree]=1[rev] (Default)
Position: 360[deg]=1[rev]
Position: 1[um]=1000[nm]
```

Context

For details refer to "Parameterization of User Units" (→ # 304).

Versions

Action	Version	Notes
Implemented	2-04-00-000	Implemented in SMM revision v0.56

General Information

Type	Read/Write
Units	User defined
Range	N/A
Default Value	1
Data Type	Integer
Stored in Non-Volatile Memory	No

9.9.1.178 AXIS#.SAFEPARAM.UNIT.POSINUSER

Description

Indicates the position increment in user units.

The safe system uses the following formula to compute the position in user units or internal values:

$$Position[counts] = position * \frac{\langle posInEncUnit \rangle}{\langle posInUserUnit \rangle} * \frac{\langle resInNbInc \rangle}{\langle resInEncUnit \rangle}$$

With:

- *posInEncUnit* is AXIS#.SAFEPARAM.UNIT.POSINENC
- *posInUserUnit* is AXIS#.SAFEPARAM.UNIT.POSINUSER
- *resInNbInc*: the encoder resolution in counts
- *resInEncUnit*: resolution in encoder units

Example

- *posInEncUnit* is AXIS#.SAFEPARAM.UNIT.POSINENC
- *posInUserUnit* is AXIS#.SAFEPARAM.UNIT.POSINUSER

```
Position: posInUserUnit [posUserUnit] = posInEncUnit [encUnit]
Position: 3600 [deciDegree] = 1 [rev] (Default)
Position: 360 [deg] = 1[rev] Position : 1[um] = 1000[nm]
```

Context

For details refer to "Parameterization of User Units" (→ # 304).

Versions

Action	Version	Notes
Implemented	2-04-00-000	Implemented in SMM revision v0.56

General Information

Type	Read/Write
Units	User defined
Range	N/A
Default Value	3600
Data Type	Integer
Stored in Non-Volatile Memory	No

9.9.1.179 AXIS#.SAFEPARAM.UNIT.POSLABEL

Description

User unit label for position values returned by the safety system. This parameter is only required for the parameter visualization in WorkBench or any other GUI. It is not used by the SMM software.

This is only applicable when a safe encoder has been defined in the safety parameters.

Value	Description
0	Degree
1	Counts
2	Rev
3	Radian
4	Arcminute
5	Meter
6	Inch

Context

For details refer to "Parameterization of User Units" (→ # 304).

Versions

Action	Version	Notes
Implemented	2-04-00-000	Implemented in SMM revision v0.56

General Information

Type	Read/Write
Units	N/A
Range	0, 1, 2, 3, 4, 5, 6
Default Value	4 (Degree)
Data Type	Integer
Stored in Non-Volatile Memory	No

9.9.1.180 AXIS#.SAFEPARAM.UNIT.VELFACTOR

Description

Indicates the velocity factor unit.

Value	Description
0	nano
1	micro
2	milli
3	centi
4	deci
5	None
6	deca
7	hecto
8	kilo

Context

For details refer to "Parameterization of User Units" (→ # 304).

Versions

Action	Version	Notes
Implemented	2-04-00-000	Implemented in SMM revision v0.56

General Information

Type	Read/Write
Units	N/A
Range	0, 1, 2, 3, 4, 5, 6, 7, 8
Default Value	5 (None)
Data Type	Integer
Stored in Non-Volatile Memory	No

9.9.1.181 AXIS#.SAFEPARAM.UNIT.VELINENC

Description

Indicates the velocity increment in encoder units.

The safe system uses the following formula:

$$Velocity[counts/s] = velocity * \frac{\langle velInEncUnit \rangle}{\langle velInUserUnit \rangle} * \frac{\langle resInNbInc \rangle}{resInEncUnit}$$

With:

- *velInEncUnit* is AXIS#.SAFEPARAM.UNIT.VELINENC
- *velInUserUnit* is AXIS#.SAFEPARAM.UNIT.VELINUSER
- *resInNbInc*: the encoder resolution in counts
- *resInEncUnit*: resolution in encoder units

Example

- *velInEncUnit* is AXIS#.SAFEPARAM.UNIT.VELINENC
- *velInUserUnit* is AXIS#.SAFEPARAM.UNIT.VELINUSER

```
Velocity : velInUserUnit[velUserUnit] = velInEncUnit[encUnit/s]
Velocity : 60[rpm]=1[rev/s]
Velocity : 1[mm/s]=1000000 [nm/s]
```

Context

For details refer to "Parameterization of User Units" (→ # 304).

Versions

Action	Version	Notes
Implemented	2-04-00-000	Implemented in SMM revision v0.56

General Information

Type	Read/Write
Units	User defined
Range	N/A
Default Value	1
Data Type	Integer
Stored in Non-Volatile Memory	No

9.9.1.182 AXIS#.SAFEPARAM.UNIT.VELINUSER

Description

Indicates the velocity increment in user units.

The safe system uses the following formula:

$$Velocity[counts/s] = velocity * \frac{\langle velInEncUnit \rangle}{\langle velInUserUnit \rangle} * \frac{\langle resInNbInc \rangle}{\langle resInEncUnit \rangle}$$

With:

- *velInEncUnit* is AXIS#.SAFEPARAM.UNIT.VELINENC
- *velInUserUnit* is AXIS#.SAFEPARAM.UNIT.VELINUSER
- *resInNbInc*: the encoder resolution in counts
- *resInEncUnit*: resolution in encoder units

Example

- *velInEncUnit* is AXIS#.SAFEPARAM.UNIT.VELINENC
- *velInUserUnit* is AXIS#.SAFEPARAM.UNIT.VELINUSER

```
Velocity : velInUserUnit[velUserUnit] = velInEncUnit[encUnit/s]
Velocity : 60[rpm]=1[rev/s]
Velocity : 1[mm/s]=1000000 [nm/s]
```

Context

For details refer to "Parameterization of User Units" (→ # 304).

Versions

Action	Version	Notes
Implemented	2-04-00-000	Implemented in SMM revision v0.56

General Information

Type	Read/Write
Units	User defined
Range	N/A
Default Value	60
Data Type	Integer
Stored in Non-Volatile Memory	No

9.9.1.183 AXIS#.SAFEPARAM.UNIT.VELLABEL

Description

User unit label for speed values returned by the safety system. This is only required for the parameter visualization in WorkBench or any other GUI. It is not used by the SMM software.

This is only applicable when a safe encoder has been defined in the safety parameters.

Value	Description
0	Counts/s
1	Degree/s
2	RPS
3	Radian/s
4	Arcminute/s
5	RPM
6	Meter/s
7	Inch/s

Context

For details refer to "Parameterization of User Units" (→ # 304).

Versions

Action	Version	Notes
Implemented	2-04-00-000	Implemented in SMM revision v0.56

General Information

Type	Read/Write
Units	N/A
Range	0, 1, 2, 3, 4, 5, 6,7
Default Value	5 (RPM)
Data Type	Integer
Stored in Non-Volatile Memory	No

9.9.1.184 BRAKE#.SAFE.SBT.ELAPSED

Description

Returns the elapsed milliseconds since the last successful Safe Brake Test (SBT) on the specified brake. When the returned time reaches the max period defined by the safety parameters

[AXIS#.SAFEPARAM.SBT.MAXTIMEINTERVAL](#), the Safe Brake Acknowledgment (SBA) signal is set to low.

Code

```
--> BRAKE1.SAFE.SBT.ELAPSED
3306031
```

Context

For complete SBT information refer to "SBT (Safe Brake Test)" (→ # 249).

Versions

Action	Version	Notes
Implemented	02-00-00-000	Implemented in SMM revision v0.32

General Information

Type	Read Only
Units	N/A
Range	N/A
Default Value	N/A
Data Type	Integer
Stored in Non-Volatile Memory	No

9.9.1.185 BRAKE#.SAFE.SBT.STATE

Description

Read the state of the Safe Brake Test (SBT) on the specified brake. The return value is one of the following:

Value	Description
0	The brake is not tested.
1	The brake has been successfully tested.
2	The brake failed to test. It may be broken.
3	The brake is applying.
4	The brake is tested.
5	The brake is releasing.

Code

```
--> BRAKE1 . SAFE . SBT . STATE
0
```

Context

For complete SBT information refer to "SBT (Safe Brake Test)" (→ # 249).

Versions

Action	Version	Notes
Implemented	02-00-00-000	Implemented in SMM revision v0.32

General Information

Type	Read Only
Units	N/A
Range	0 - 7
Default Value	N/A
Data Type	Integer
Stored in Non-Volatile Memory	No

9.9.1.186 SAFE.CFGERROR

Description

In case the safety parameters validation fails due to invalid configuration, this parameter returns information about which parameters failed to validate and why.

Code

```
--> SAFE.CFGERROR
```

```
Parameter: [PARAMETER_NUMBER] PARAMETER_KEYWORD_NAME
```

```
Axis: AXIS_ID
```

```
Instance: INSTANCE_ID
```

```
Error: [ERROR_NUMBER] ERROR_DESCRIPTION
```

Context

For information on validation refer to "Validation" (→ # 307).

Versions

Action	Version	Notes
Implemented	02-00-00-000	Implemented in SMM revision v0.32

General Information

Type	Read Only
Units	N/A
Range	N/A
Default Value	N/A
Data Type	String
Stored in Non-Volatile Memory	No

9.9.1.187 SAFE.CHANGEPASSWORD

Description

Change or create the password used for safety parameters operation. The master password remains unchanged and valid. The password must be at least 8 characters long but not more than 25 characters. This password cannot be retrieved if lost but the master password can be used to reset it.

NOTE

The master password is SafeMotionMonitorXXX where XXX are the last 3 digits of the drive serial number.

Usage

SAFE.CHANGEPASSWORD <new_password> <confirmation_password>

All parameters are mandatory. The drive will return an error if:

- Not enough parameters are provided .
- Too much parameters are provided .
- At least one of the parameter is out of range.
- The confirmation password is not valid (error returned by the SMM)

NOTE

The password strings cannot contain any spaces.

<new_password>: String of 8 bytes min and 25 bytes max

<confirmation_password>: String of 8 bytes min and 25 bytes max

Versions

Action	Version	Notes
Implemented	02-00-00-000	Implemented in SMM revision v0.32

General Information

Type	Command
Units	N/A
Range	N/A
Default Value	N/A
Data Type	N/A
Stored in Non-Volatile Memory	No

9.9.1.188 SAFE.CLEARSAFEID

Description

Clear the SafeID and invalidate the safety parameters. It clears the SafeID and invalidate the safety parameters and in consequence the SMM will go in a safe-state "SafeID not validated" (SAFE.STATE is 2). The SafeID can now be changed using the physical rotary-switches and then the drive must be rebooted to re-validate the SafeID.

Usage

```
Format is: SAFE.CLEARSAFEID <user_name> <password> <date_and_time>
```

```
<user_name>: Username used to perform the safety parameters operation. Max 8 characters.
```

```
<password>: Password used for safety parameters operation. Min 8 characters, max 25 characters.
```

```
<date_and_time>: Format is YYYY-MM-DDThh:mm:ssZ.
```

Example: 2019-02-05T16:10:10Z which is 5th of February 2019, 16:10:10 UTC. Time zone must always UTC.

Example: SAFE.CLEARSAFEID john my_password 2019-02-05T16:10:10Z

Context

For information on validation refer to "Validation" (→ # 307).

Versions

Action	Version	Notes
Implemented	02-00-00-000	Implemented in SMM revision v0.32

General Information

Type	Command
Units	N/A
Range	N/A
Default Value	N/A
Data Type	N/A
Stored in Non-Volatile Memory	No

9.9.1.189 SAFE.CRC

Description

Returns the Cyclic Redundancy Check (CRC) of the complete safety parameters file stored in this device. The CRC returned is 0, if there are no safety parameters available.

Bytes 0..3: System CRC

SAFE.CRC is accessible through telnet.

CoE gives the CRC (Index: 0x37C3, SubIndex: 0).

Code

```
--> SAFE.CRC
0x31a564de
```

Context

For information on validation and CRC refer to "Validation" (→ # 307).

Versions

Action	Version	Notes
Implemented	02-00-00-000	Implemented in SMM revision v0.32

General Information

Type	Read Only
Units	N/A
Range	All
Default Value	N/A
Data Type	Integer
Stored in Non-Volatile Memory	No

9.9.1.190 SAFE.DEVICECRC

Description

Returns the Cyclic Redundancy Check (CRC) of the device's safety parameters dedicated to this device stored inside the complete safety parameters file. If there are no safety parameters available, the CRC returned is 0.

Code

```
--> SAFE.DEVICECRC
0x72d5a4df
```

Context

For information on CRC and validation refer to "Validation" (→ # 307).

Versions

Action	Version	Notes
Implemented	02-00-00-000	Implemented in SMM revision v0.32

General Information

Type	Read Only
Units	N/A
Range	All
Default Value	N/A
Data Type	Integer
Stored in Non-Volatile Memory	No

9.9.1.191 SAFE.ERROR

Description

Indicates the current error code of the SMM. Possible values of SAFE.ERROR are:

ID	Failure	Comments
0	No fault	
1	Safe input fault	
2	SDB failure	
3	Safe output fault	
4	STO output fault	
5	Encoder startup timeout	The communication with the encoder reported a fatal problem. The timeout for the startup of the encoder occurred.
6	Encoder fault: No position available	No encoder position is available but is needed. No valid data is available.
7	Power supply fault (Vcc)	Undervoltage led to a reset of the SMM.
8	Black-channel fault	The safe fieldbus detected a failure.
9..11	Fatal faults	No transmission to drive because there is no active communication.
12	Safety parameter invalid	The drive enters a safe state engaging the brake and removing power simultaneously. This happens when the configured sequence is unknown.
13	Brake output fault	
14	Temperature fault	The temperature cools when the drive is switched off.
15	Internal discrepancy	A discrepancy between two micro controllers on the SMM was detected.
16	FPGA not suitable	The FPGA software is not suitable for use with this SMM.
17	Internal fault	Error occurred.
18	I/O Fault	Error occurred which can be fixed.
19	Reserved	
20	External memory fault	A failure occurred at the external non-volatile memory.
21	Manufacturing parameter invalid	The manufacturing data is invalid.
22	External discrepancy	The two inputs used for a dual input are different.
23	Brake current fault	The brake current is out of range.
24	Encoder fault: No speed available	No speed is available but is needed. No valid data is available.
25	Encoder fault: Invalid association	The association of the encoder to an axis is invalid. No valid data is available.
26	Encoder fault: Invalid type	The encoder type is invalid. No valid data is available.
27	Encoder fault: Communication Channel 1	The encoder communication failed on channel 1. No valid data is available.
28	Encoder fault: Communication Channel 2	The encoder communication failed on channel 2. No valid data is available.
29	Encoder fault: Communication timeout	The encoder reported a timeout in the communication. No valid data is available.
30	Encoder fault: Diagnostic test	The encoder reported an error in the diagnostic test. No valid data is available.
31	Encoder fault: Event Channel 1	The encoder reported an error on channel 1. No valid data is available.

ID	Failure	Comments
32	Encoder fault: Event Channel 2	The encoder reported an error on channel 2. No valid data is available.
33	Encoder fault: Position Drift	The position between channel 1 and 2 is different. No valid data is available.
34	Encoder fault: Startup error	The encoder reported a failed startup test. No valid data is available.
35	Encoder fault: Encoder counter drift	Note: Error only applicable for SMM R_02-07-000. The message counters of the channels of an encoder differ more than expected.
36	Encoder fault: Encoder update rate	Note: Error only applicable for SMM R_02-07-000. The encoder position update rate is out of tolerance.

Code

```
--> SAFE.ERROR
0
```

Context

For information on validation refer to "Safety Faults, Safety Warnings" (→ # 311).

Versions

Action	Version	Notes
Implemented	02-00-00-000	Implemented in SMM revision v0.32

General Information

Type	Read Only
Units	N/A
Range	0, 1, 2, 3, 4, 5, 6, 7, 8, 9, 10
Default Value	N/A
Data Type	Integer
Stored in Non-Volatile Memory	No

9.9.1.192 SAFE.ERRORINSTANCE

Description

Indicates the current instance of the error code returned by [SAFE.ERROR](#) (if applicable).

The parameter returns 0 when there is no instance or no error. If not, it returns the instance ID (for example, it returns 1 for Axis 1). The instance is dependent on the value returned by [SAFE.ERROR](#). Depending on the context, it could be an Axis ID, Brake ID, encoder ID or Safe I/O ID.

Code

```
--> SAFE.ERRORINSTANCE
1
```

Versions

Action	Version	Notes
Implemented		Implemented in SMM revision v0.53

General Information

Type	Read Only
Units	N/A
Range	N/A
Default Value	N/A
Data Type	Integer
Stored in Non-Volatile Memory	No

9.9.1.193 SAFE.ID

Description

Returns the SafeID of the device. The SafeID returned is 0, if there are no SafeID available.
SAFE.ID is accessible through telnet.

Code

```
--> SAFE.ID
0x31
```

Context

For information on validation and CRC refer to "Validation" (→ # 307).

Versions

Action	Version	Notes
Implemented	02-00-00-000	Implemented in SMM revision v0.32

General Information

Type	Read Only
Units	N/A
Range	All
Default Value	N/A
Data Type	Integer
Stored in Non-Volatile Memory	No

9.9.1.194 SAFE.IDANDCRC

Description

Returns the Cyclic Redundancy Check (CRC) and the SafeID of the complete safety parameters file stored in this device. The CRC returned is 0, if there are no safety parameters available.

Bytes 0..3: System CRC

Byte 4: SafeID

SAFE.IDANDCRC is accessible through telnet.

Code

```
--> SAFE.IDANDCRC
0x1031a564de
```

Context

For information on validation and CRC, refer to "Validation" (→ # 307).

Versions

Action	Version	Notes
Implemented	02-00-00-000	Implemented in SMM revision v0.32

General Information

Type	Read Only
Units	N/A
Range	All
Default Value	N/A
Data Type	Integer
Stored in Non-Volatile Memory	No

9.9.1.195 SAFE.INVALIDATEPARAMS

Description

Invalidate the safety parameters. This command is executed when the SMM is in "operational" (SAFE.STATE is 6). It will invalidate the safety parameters and in consequence the SMM will go in a safe-state "configuration needed" (SAFE.STATE is 3).

Usage

```
Format is: SAFE.INVALIDATEPARAMS <user_name> <password> <date_and_time>
```

<user_name>: Username used to perform the safety parameters operation. Max 8 characters.

<password>: Password used for safety parameters operation. Min 8 characters, max 25 characters.

<date_and_time>: Format is YYYY-MM-DDThh:mm:ssZ.

Example: 2019-02-05T16:10:10Z which is 5th of February 2019, 16:10:10 UTC. Time zone must always be UTC.

Example: SAFE.INVALIDATEPARAMS john my_password 2019-02-05T16:10:10Z

Context

For more information refer to "Validation" (→ # 307) and "Downloading Safety Parameter Packages" (→ # 297).

Versions

Action	Version	Notes
Implemented	02-00-00-000	Implemented in SMM revision v0.32

General Information

Type	Command
Units	N/A
Range	N/A
Default Value	N/A
Data Type	N/A
Stored in Non-Volatile Memory	No

9.9.1.196 SAFE.MONITOR#.AXIS

Description

Defines the axis of the monitored SMM variable returned by SAFE.MONITOR#.DATA. Two variables can be configured at the same time using SAFE.MONITOR1.AXIS and SAFE.MONITOR2.AXIS.

Code

```
--> SAFE.MONITOR1.AXIS 1
```

Versions

Action	Version	Notes
Implemented	02-00-00-000	Implemented in SMM revision v0.32

General Information

Type	Read/Write
Units	N/A
Range	1 to 2 on dual axis product. 1 on single axis product
Default Value	1
Data Type	N/A
Stored in Non-Volatile Memory	No

9.9.1.197 SAFE.MONITOR#.DATA

Description

Reads the value of the monitored SMM variables. Two variables can be read at the same time using SAFE.MONITOR1.DATA and SAFE.MONITOR2.DATA. The variable to monitor is configured by using SAFE.MONITOR#.SOURCE, SAFE.MONITOR#.AXIS and SAFE.MONITOR#.INSTANCE.

Code

```
--> SAFE.MONITOR1.DATA
1
```

Versions

Action	Version	Notes
Implemented	02-00-00-000	Implemented in SMM revision v0.32

General Information

Type	Read Only
Units	N/A
Range	N/A
Default Value	N/A
Data Type	Integer
Stored in Non-Volatile Memory	No

9.9.1.198 SAFE.MONITOR#.INSTANCE

Description

Defines the instance of the monitored SMM variable returned by [SAFE.MONITOR#.DATA](#). Two variables can be configured at the same time using `SAFE.MONITOR1.INSTANCE` and `SAFE.MONITOR2.INSTANCE`.

Code

```
--> SAFE.MONITOR1.INSTANCE 1
```

Versions

Action	Version	Notes
Implemented	02-00-00-000	Implemented in SMM revision v0.32

General Information

Type	Read/Write
Units	N/A
Range	1 to 4
Default Value	1
Data Type	N/A
Stored in Non-Volatile Memory	N/A

9.9.1.199 SAFE.MONITOR#.SOURCE

Description

Defines the source of the monitored safe variable SAFE.MONITOR#.DATA. Two variables can be configured at the same time using SAFE.MONITOR1.SOURCE and SAFE.MONITOR2.SOURCE. The source can be one of the following values:

Value	Content
1	Current state of the internal state machine of the STO function
2	Current state of the internal state machine of the SS1 function
3	Current state of the internal state machine of the SBC function
4	Current state of the internal state machine of the brake (Axis information is ignored, Two instances for brake 1 and 2 are provided)
5	Safe position of axis
6	Safe absolute position of axis
7	Acceleration of axis
8	Speed of axis
9	Current state of the internal state machine of the SSM function
10	Current state of the internal state machine of the SOS function
11	Current state of the internal state machine of the SSR function
12	Current state of the internal state machine of the SDIp function
13	Current state of the internal state machine of the SDIn function
14	Current state of the internal state machine of the SCA function
15	Current state of the internal state machine of the SLA function
16	Current state of the internal state machine of the SLS function
17	Current state of the internal state machine of the SS2 function
18	Current state of the internal state machine of the SLI function
19	Current state of the internal state machine of the SLP function
20	Current state of the internal state machine of the SAR function

Code

```
--> SAFE.MONITOR1.SOURCE 2
```

Versions

Action	Version	Notes
Implemented	02-00-00-000	Implemented in SMM revision v0.32

General Information

Type	Read/Write
Description	Source of the monitored SMM variable
Units	N/A
Range	0 to 20
Default Value	1
Data Type	N/A

9.9.1.200 SAFE.STATE

Description

SAFE.STATE indicates the current state of the SMM. It's accessible through telnet and through CoE (Index: 0x37C1, SubIndex: 0). The possible values of SAFE.STATE are:

Value	Name	Description
0, 16...254	Invalid	Reserved.
1	Start-up	The SMM is starting up. This will be present, while the connection to the safe fieldbus starts up.
2	SafeID not validated	SafeID is not validated or invalid. Validation process required.
3	Configuration required	A new configuration is required. The configuration of the SMM may be broken.
4	Configuration invalid	The last configuration is invalid and new configuration is required.
5	Parameter validation required	Safety parameters are not validated.
6	Normal operation	The SMM is working normally. In this state, STO or the brake may be active.
7	Safe brake test	A brake test is occurring. The test will be triggered by the drive processor. This state is activated for the complete device, even though only a single axis is tested.
8	IO Failure	The SMM detected a fault that may be acknowledged. During this state STO and the brakes will be active.
9	Internal Failure	Some catastrophic failure occurred. The SMM does not release operation until it was power cycled.

Code

```
--> SAFE.STATE
6
```

Versions

Action	Version	Notes
Implemented	02-00-00-000	Implemented in SMM revision v0.32

General Information

Type	Read Only
Units	N/A
Range	1, 2, 3, 4, 5, 6, 7, 8, 9, 255
Default Value	N/A
Data Type	Integer
Stored in Non-Volatile Memory	No

9.9.1.201 SAFE.SWITCH

Description

Returns a value defined by the state of the two rotary switches S1 and S2. The returned value is equal to $(10 \cdot S1 + S2)$. When this value is validated, it becomes the SafeID.

Code

```
--> SAFE.SWITCH
16
```

Versions

Action	Version	Notes
Implemented	02-00-00-000	Implemented in SMM revision v0.32

General Information

Type	Read Only
Units	N/A
Range	0 or 1
Default Value	N/A
Data Type	Integer
Stored in Non-Volatile Memory	No

9.9.1.202 SAFE.VALIDATEPARAM

Description

Validates the safety parameters. Safety parameters must first be downloaded to the device.

Format is: SAFE.VALIDATE <user_name> <password> <date_and_time> <safe_id>

All parameters are mandatory. The drive will return an error if:

- Not enough parameters are provided
- Too many parameters are provided
- At least one of the parameter is out of range.

Note that the user_name and the password strings cannot contain any spaces.

- <user_name>: String of 8 bytes max
- <password>: String of 8 bytes min and 25 bytes max
- <date_and_time>: In the format defined by the RFC3339. The date must be in the UTC time zone.

Code

```
--> SAFE.VALIDATE john john_password 2019-02-22T10:58:30Z 16
```

Context

For more information refer to "Validation" (→ # 307) and "Downloading Safety Parameter Packages" (→ # 297).

Versions

Action	Version	Notes
Implemented	02-00-00-000	Implemented in SMM revision v0.32

General Information

Type	Command
Units	N/A
Range	N/A
Default Value	N/A
Data Type	N/A
Stored in Non-Volatile Memory	No

9.9.1.203 SAFE.VALIDATIONLOG

Description

Returns logged information about safety parameters validation and SafeID management. First displayed entry is the newest one (Index: 0). 32 entries can be stored at a maximum. Each entry contains:

- A username to indicate who performs the operation. Note that for the SafeID the user validation is done using the push button. Then the user recorded is called HW_BUTTON.
- An information string can be:
 - "PARAM VAL (X, Z)" for safety parameters validation where X is the SafeID and Z is the CRC of the validated safety parameters.
 - "PARAM CLR (X)" for safety parameters invalidation where X is the SafeID.
 - "ID VAL (X)" for SafeID validation where X is the validated SafeID.
 - "ID CLR" for SafeID invalidation.
- A date in the format defined by the RFC3339. The date is always in UTC time zone. No date is recorded when the SafeID is validated (user operation through push button).

Code

```
--> SAFE.VALIDATIONLOG
```

```
0;john;PARAM VAL (16, 0x3F3A0F07);2019-02-18T14:58:55Z
```

```
1;rob;PARAM VAL (16, 0x3F3A0F07);2019-02-01T15:19:09Z
```

```
2;HW BTN;ID VAL (16);0000-00-00T00:00:00Z
```

```
3;john;PARAM CLR (16);2019-01-31T14:39:39Z
```

```
4;john;ID CLR;2019-01-31T14:39:39Z
```

```
5;john;PARAM VAL (16, 0x3F3A0F07);2019-01-31T14:58:19Z
```

```
6;john;PARAM CLR (16);2019-01-31T14:39:39Z
```

Context

For more information refer to "Validation" (→ # 307).

Versions

Action	Version	Notes
Implemented	02-00-00-000	Implemented in SMM revision v0.32

General Information

Type	Read Only
Units	N/A
Range	N/A
Default Value	N/A
Data Type	String
Stored in Non-Volatile Memory	No

9.9.1.204 SAFE.VERIFYFW

Description

Sets the username, password, and checksum that is used for an SMM firmware update. WorkBench automatically sends this command when using the firmware update dialog window. Once this command is sent, SMM firmware must be sent by HTTP within 30 seconds.

Usage

Format is: SAFE.VERIFYFW <user_name> <password> <checksum>
 <user_name>: Username used to perform the safety firmware update. Max 8 characters.
 <password>: Password used for safety firmware update. Min 8 characters, max 25 characters.
 <checksum>: Checksum of the firmware update binary.

Example: SAFE.VERIFYFW john my_password 0xa1878800

Versions

Action	Version	Notes
Implemented	02-00-00-000	

General Information

Type	Command
Units	N/A
Range	N/A
Default Value	N/A
Data Type	N/A
Stored in Non-Volatile Memory	No

9.9.1.205 SAFEPARAM.ENCODERHDSLTYPE1

Description

Defines the HIPERFACE DSL encoder type linked to the first encoder interface. 8 different types are supported:

Value	Description
0	Unused
1	EKS36
2	EKM36
3	EES37
4	EEM37
5	EFS50
6	EFM50
7	EDS35
8	EDM35

The encoder interface can be used when linked to an axis (see [AXIS#.SAFEPARAM.ENCODERSOURCE](#)).

General Information

Type	Read/Write
Units	N/A
Range	0, 1, 2, 3, 4, 5, 6, 7, 8
Default Value	0
Data Type	Integer
Stored in Non-Volatile Memory	No

9.9.1.206 SAFEPARAM.ENCODERHDSLTYPE2

Description

Defines the HIPERFACE DSL encoder type linked to the second encoder interface. 8 different types are supported:

Value	Description
0	Unused
1	EKS36
2	EKM36
3	EES37
4	EEM37
5	EFS50
6	EFM50
7	EDS35
8	EDM35

The encoder interface can be used when linked to an axis (see [AXIS#.SAFEPARAM.ENCODERSOURCE](#)).

Versions

Action	Version	Notes
Implemented	2-04-00-000	Implemented in SMM revision v0.56

General Information

Type	Read/Write
Units	N/A
Range	0, 1, 2,3,4,5,6,7,8
Default Value	0
Data Type	Integer
Stored in Non-Volatile Memory	No

9.9.1.207 SAFEPARAM.HDSLCHAN1SINGLETURNRES1

Description

Defines the singleturn resolution for the first channel of the HIPERFACE DSL encoder linked to the first encoder interface. It corresponds to the non-safe singleturn resolution.

General Information

Type	Read/Write
Units	Bits
Range	[0, 24]
Default Value	0
Data Type	Integer
Stored in Non-Volatile Memory	No

9.9.1.208 SAFEPARAM.HDSLCHAN1SINGLETURNRES2

Description

Defines the singleturn resolution for the first channel of the HIPERFACE DSL encoder linked to the second encoder interface. It corresponds to the non-safe singleturn resolution.

General Information

Type	Read/Write
Units	Bits
Range	[0, 24]
Default Value	0
Data Type	Integer
Stored in Non-Volatile Memory	No

9.9.1.209 SAFEPARAM.IOFAILUREACKSOURCE

Description

Indicates which safe input, if any, is configured as the I/O Failure acknowledge source. This parameter is configured using FSoE or WorkBench . When configured, it allows clearing of an I/O Failure warning (W9011) using the configured safety input.

Versions

Action	Version	Notes
Implemented	02-01-02-000	

General Information

Type	Read/Write
Units	N/A
Range	0...4
Default Value	0 (No safe input)
Data Type	Integer
Stored in Non-Volatile Memory	No

9.9.1.210 SAFEPARAM.SAFEFIELDBUS.ACTIVATION

With this parameter, the user configures if the safe fieldbus can have control of the safety functions. The following table shows the possible settings for the different use cases:

Case	Safety parameter configuration using	Use of FSoE connection	Safe fieldbus activation setting
1	WorkBench	Yes	Activated
2	WorkBench	No	Not activated
3	SRA (FSoE)	Yes	Activated*
4	FoE	Yes	Activated
5	FoE	No	Not activated

*automatically set when the connection is established and no valid safety configuration is present.

NOTE

If there is no valid safety configuration, but the FSoE master tries to establish a safety connection **without** SRA parameters, the connection is rejected.

Case 1: If this parameter is activated through safety configuration using WorkBench, the drive expects a FSoE connection and stays in safe state until this connection is successfully established. **Only if this parameter is activated, then** a safety function is allowed to be controlled by FSoE or activated by local safe digital inputs.

Case 2: If this parameter is set to “Not activated” in the safety configuration using WorkBench, safety functions can **only** be activated by local safe digital inputs.

Case 3: If there is no valid safety configuration, this parameter has the value “not activated”. However, if the FSoE master provides valid safety configuration through SRA parameters, the safety function can be assigned to be activated by FSoE or local safe digital inputs and SAFEFIELDBUS.ACTIVATION is set to “Activated”.

Case 4: Same behavior as “case 1”, but the parameter file is downloaded using EtherCAT master.

Case 5: Same behavior as “case 2”, but the parameter file is downloaded using EtherCAT master.

NOTE

If a safety function is activated through FSoE, it is required this parameter is set to “Activated” and the parameter “FSoE” of the safety function is set to “Used”, e.g., for the STO function the parameter name is “SAFEPARAM.STO.FSOE”..

NOTE

Versions

Action	Version	Notes
Implemented	02-01-02-000	

General Information

Type	Read/Write
Units	N/A
Range	0 (Not Activated) or 1 (Activated)
Default Value	Default (WorkBench): 0 (Not Activated) Default (FSoE): 1 (Activated)
Data Type	Integer
Stored in Non-Volatile Memory	No

9.9.1.211 SAFEPARAM.SIN.DISTINCTPULSE

Description

This setting indicates whether pulses on safe inputs must all be distinct from each other (i.e., offset from each other or different periods).

NOTE

This does not disable the check for pulses on safe inputs. It only allows or disallows having the same pulse signal across safe inputs.

NOTE

Versions

Action	Version	Notes
Implemented	02-01-02-000	

General Information

Type	Read/Write
Units	N/A
Range	0 (Disabled) or 1 (Enabled)
Default Value	0 (Disabled)
Data Type	Integer
Stored in Non-Volatile Memory	No

9.9.1.212 SAFEPARAM.SINDUAL#.EN

Description

Enables dual safe inputs for SIN (Safe INput)1-4.

NOTE

The corresponding single safety inputs are not allowed to be used when being used in a dual configuration. Safety functions must be configured with the dual input.

NOTE
NOTE

When enabled, paired inputs must be transitioned together within a certain period or an I/O failure warning ("W9011 " (→ # 313)) will occur putting the drive in a safe state.

NOTE

Context

For more information, see "Safe Digital Inputs" (→ # 210)

Versions

Action	Version	Notes
Implemented	2-00-02-000	

General Information

Type	Read/Write
Units	N/A
Range	0 (Disabled) or 1 (Enabled)
Default Value	0 (Disabled)
Data Type	Integer
Stored in Non-Volatile Memory	No

9.9.1.213 SAFEPARAM.SOUTDUAL#.EN

Description

Indicates whether the safe outputs are configured as dual outputs or not. When configured as dual, the paired outputs are triggered together.

Context

For more information, see "Safe Digital Outputs" (→ # 211)

Versions

Action	Version	Notes
Implemented	02-01-02-000	

General Information

Type	Read/Write
Units	N/A
Range	0 (Disabled) or 1 (Enabled)
Default Value	0 (Disabled)
Data Type	Integer
Stored in Non-Volatile Memory	No

9.9.1.214 SAFEPARAM.SOUTDUAL#.SOURCE

Description

When outputs are configured for dual outputs, this controls what safety function will trigger the safe output.

NOTE

WorkBench will not allow the user to select this setting unless the corresponding SOUTDUAL# is enabled. See [SAFEPARAM.SOUTDUALx.EN](#).

Value	Description	Value	Description	Value	Description	Value	Description
0x00	Off, no output signal driven	0x13	SLS – Axis 2 Instance 2	0x26	SAR – Axis 2 Instance 1	0x39	SCA – Axis 2 Instance 2
0x01	STO – Axis 1	0x14	SLS – Axis 2 Instance 3	0x27	SAR – Axis 2 Instance 2	0x3A	SCA – Axis 2 Instance 3
0x02	STO – Axis 2	0x15	SSM – Axis 1	0x28	SAR – Axis 2 Instance 3	0x3B	SDB – Axis 1
0x03	SS1 – Axis 1 Instance 1	0x16	SSM – Axis 2	0x29	SLI – Axis 1 Instance 1	0x3C	SDB – Axis 2
0x04	SS1 – Axis 1 Instance 2	0x17	SSR – Axis 1 Instance 1	0x2A	SLI – Axis 1 Instance 2	0x3D	SBC – Axis 1
0x05	SS1 – Axis 1 Instance 3	0x18	SSR – Axis 1 Instance 2	0x2B	SLI – Axis 1 Instance 3	0x3E	SBC – Axis 2
0x06	SS1 – Axis 2 Instance 1	0x19	SSR – Axis 1 Instance 3	0x2C	SLI – Axis 2 Instance 1	0x3F	SBA – Axis 1
0x07	SS1 – Axis 2 Instance 2	0x1A	SSR – Axis 2 Instance 1	0x2D	SLI – Axis 2 Instance 2	0x40	SBA – Axis 2
0x08	SS1 – Axis 2 Instance 3	0x1B	SSR – Axis 2 Instance 2	0x2E	SLI – Axis 2 Instance 3	0x43	Ready signal (always on)
0x09	SS2 – Axis 1 Instance 1	0x1C	SSR – Axis 2 Instance 3	0x2F	SLP – Axis 1 Instance 1	0x45	Restart acknowledge request – Axis 1
0x0A	SS2 – Axis 1 Instance 2	0x1D	SDIp – Axis 1	0x30	SLP – Axis 1 Instance 2	0x46	Restart acknowledge request – Axis 2
0x0B	SS2 – Axis 2 Instance 1	0x1E	SDIp – Axis 2	0x31	SLP – Axis 1 Instance 3	0xFF	Always On
0x0C	SS2 – Axis 2 Instance 2	0x1F	SDIn – Axis 1	0x32	SLP – Axis 2 Instance 1		
0x0D	SOS – Axis 1	0x20	SDIn – Axis 2	0x33	SLP – Axis 2 Instance 2		
0x0E	SOS – Axis 2	0x21	SLA – Axis 1	0x34	SLP – Axis 2 Instance 3		
0x0F	SLS – Axis 1 Instance 1	0x22	SLA – Axis 2	0x35	SCA – Axis 1 Instance 1		
0x10	SLS – Axis 1 Instance 2	0x23	SAR – Axis 1 Instance 1	0x36	SCA – Axis 1 Instance 2		
0x11	SLS – Axis 1 Instance 3	0x24	SAR – Axis 1 Instance 2	0x37	SCA – Axis 1 Instance 3		
0x12	SLS – Axis 2 Instance 1	0x25	SAR – Axis 1 Instance 3	0x38	SCA – Axis 2 Instance 1		

Context

For more information, see "Safe Digital Outputs" (→ # 211)

Versions

Action	Version	Notes
Implemented	02-01-02-000	

General Information

Type	Read/Write
Units	N/A
Range	0x00-0xFF
Default Value	0x00 (Off)
Data Type	Integer
Stored in Non-Volatile Memory	No

9.9.1.215 SAFEPARAM.SOUT#.SOURCE

Description

When outputs are configured for single outputs, this controls what safety function triggers the safe output.

NOTE

WorkBench will not allow the user to select this setting if the corresponding output is being used in dual output mode. See [SAFEPARAM.SOUTDUALx.EN](#).

NOTE

Value	Description	Value	Description	Value	Description	Value	Description
0x00	Off, no output signal driven	0x13	SLS – Axis 2 Instance 2	0x26	SAR – Axis 2 Instance 1	0x39	SCA – Axis 2 Instance 2
0x01	STO – Axis 1	0x14	SLS – Axis 2 Instance 3	0x27	SAR – Axis 2 Instance 2	0x3A	SCA – Axis 2 Instance 3
0x02	STO – Axis 2	0x15	SSM – Axis 1	0x28	SAR – Axis 2 Instance 3	0x3B	SDB – Axis 1
0x03	SS1 – Axis 1 Instance 1	0x16	SSM – Axis 2	0x29	SLI – Axis 1 Instance 1	0x3C	SDB – Axis 2
0x04	SS1 – Axis 1 Instance 2	0x17	SSR – Axis 1 Instance 1	0x2A	SLI – Axis 1 Instance 2	0x3D	SBC – Axis 1
0x05	SS1 – Axis 1 Instance 3	0x18	SSR – Axis 1 Instance 2	0x2B	SLI – Axis 1 Instance 3	0x3E	SBC – Axis 2
0x06	SS1 – Axis 2 Instance 1	0x19	SSR – Axis 1 Instance 3	0x2C	SLI – Axis 2 Instance 1	0x3F	SBA – Axis 1
0x07	SS1 – Axis 2 Instance 2	0x1A	SSR – Axis 2 Instance 1	0x2D	SLI – Axis 2 Instance 2	0x40	SBA – Axis 2
0x08	SS1 – Axis 2 Instance 3	0x1B	SSR – Axis 2 Instance 2	0x2E	SLI – Axis 2 Instance 3	0x43	Ready signal (always on)
0x09	SS2 – Axis 1 Instance 1	0x1C	SSR – Axis 2 Instance 3	0x2F	SLP – Axis 1 Instance 1	0x45	Restart acknowledge request – Axis 1
0x0A	SS2 – Axis 1 Instance 2	0x1D	SDIp – Axis 1	0x30	SLP – Axis 1 Instance 2	0x46	Restart acknowledge request – Axis 2
0x0B	SS2 – Axis 2 Instance 1	0x1E	SDIp – Axis 2	0x31	SLP – Axis 1 Instance 3	0xFF	Always On
0x0C	SS2 – Axis 2 Instance 2	0x1F	SDIn – Axis 1	0x32	SLP – Axis 2 Instance 1		
0x0D	SOS – Axis 1	0x20	SDIn – Axis 2	0x33	SLP – Axis 2 Instance 2		
0x0E	SOS – Axis 2	0x21	SLA – Axis 1	0x34	SLP – Axis 2 Instance 3		
0x0F	SLS – Axis 1 Instance 1	0x22	SLA – Axis 2	0x35	SCA – Axis 1 Instance 1		
0x10	SLS – Axis 1 Instance 2	0x23	SAR – Axis 1 Instance 1	0x36	SCA – Axis 1 Instance 2		
0x11	SLS – Axis 1 Instance 3	0x24	SAR – Axis 1 Instance 2	0x37	SCA – Axis 1 Instance 3		
0x12	SLS – Axis 2 Instance 1	0x25	SAR – Axis 1 Instance 3	0x38	SCA – Axis 2 Instance 1		

Context

For more information, see "Safe Digital Outputs" (→ # 211)

Versions

Action	Version	Notes
Implemented	02-01-02-000	

General Information

Type	Read/Write
Units	N/A
Range	0x00-0xFF
Default Value	0x00 (Off)
Data Type	Integer
Stored in Non-Volatile Memory	No

9.9.1.216 SINDUAL#.STATE

Description

Reads the state of one safe dual digital input according to the number identified in the command. The safe dual input is composed of two physical safe inputs. The configuration of the safe dual input is determined by the safety parameters.

Usage

The state of the safe dual input is determined by the state of the two underlying safe inputs.

SIN1.STATE	SIN2.STATE	SINDUAL1.STATE
0	0	0
1	0	I/O failure
0	1	I/O failure
1	1	1

When dual channel mode is selected the drive supervises if the two inputs are in a different state for longer than 100 ms. If this occurs, an I/O failure fault is generated and the drive is put in safe-state.

Context

For more information, see "Safe Digital Inputs" (→ # 210)

Versions

Action	Version	Notes
Implemented	02-00-00-000	Implemented in SMM revision v0.32

General Information

Type	Read Only
Units	N/A
Range	0 or 1
Default Value	N/A
Data Type	Integer
Stored in Non-Volatile Memory	No

9.9.1.217 SIN#.STATE

Description

SIN1 to SIN4. Reads the state of one safe digital input according to the number identified in the command.

Context

For more information, see "Safe Digital Inputs" (→ # 210) and "OSSD" (→ # 212)

Versions

Action	Version	Notes
Implemented	02-00-00-000	Implemented in SMM revision v0.32

General Information

Type	Read Only
Units	N/A
Range	0 or 1
Default Value	N/A
Data Type	Integer
Stored in Non-Volatile Memory	No

9.9.1.218 SOUTDUAL#.STATE

Description

Reads the state of one safe dual digital output according to the number identified in the command. The safe dual output is composed of two physical safe outputs. The configuration of the safe dual output is determined by the safety parameters.

Usage

When dual channel mode is selected, the drive drives the two selected safe outputs as they were one safe output.

SOUT1.STATE	SOUT2.STATE	SOUTDUAL1.STATE
0	0	0
1	0	N/A
0	1	N/A
1	1	1

Context

For more information, see "Safe Digital Outputs" (→ # 211)

Versions

Action	Version	Notes
Implemented	02-00-00-000	Implemented in SMM revision v0.32

General Information

Type	Read Only
Units	N/A
Range	0 or 1
Default Value	N/A
Data Type	Integer
Stored in Non-Volatile Memory	No

9.9.1.219 SOUT#.STATE

Description

SOUT1 to SOUT4. Reads the state of one safe digital output according to the number identified in the command.

Context

For more information, see "Safe Digital Outputs" (→ # 211)

Versions

Action	Version	Notes
Implemented	02-00-00-000	Implemented in SMM revision v0.32

General Information

Type	Read Only
Units	N/A
Range	0 or 1
Default Value	N/A
Data Type	Integer
Stored in Non-Volatile Memory	No

10 Approvals

NOTICE

If the drive is labeled Beta, approvals are pending.

10.1 Conformance with UL/cUL	547
10.2 Conformance with EU	549
10.3 Conformance with UK	550

10.1 Conformance with UL/cUL

10.1.1 3-12 A drives

This drive is listed under UL (Underwriters Laboratories Inc.) file number **E141084**.

USL, CNL - Power conversion equipment (NMMS, NMMS7)

USL (United States Standards - Listed): Indicates Investigated to United States Standard for Power Conversion Equipment, UL 61800-5-1.

CNL (Canadian National Standards - Listed): Indicates investigation to Canadian Standard for Industrial Control Equipment, CAN/CSA - C22.2, No. 274-17.

UL Markings / Marquages UL

English	Français
<ul style="list-style-type: none"> Integral solid state short circuit protection does not provide branch circuit protection. Branch circuit protection must be provided in accordance with the National Electrical Code and any additional local codes. 	<ul style="list-style-type: none"> Une protection de court-circuit à semi-conducteur intégrale ne fournit pas de protection de la dérivation. Il convient de garantir une protection de la dérivation conforme au NEC et aux réglementations locales en vigueur.
<ul style="list-style-type: none"> This product is suitable for use on a circuit capable of delivering not more than 10kA (SCCR) when protected by class J fuses or circuit breakers, and of delivering not more than 65kA (SCCR) when protected by semi-conductor fuses. 	<ul style="list-style-type: none"> Ce produit peut être utilisé sur un circuit capable de délivrer un maximum de 10 kA (SCCR) lorsqu'il est protégé par des fusibles ou des disjoncteurs de classe J, et de délivrer un maximum de 65 kA (SCCR) lorsqu'il est protégé par des fusibles à semi-conducteurs.
<ul style="list-style-type: none"> Suitable for motor group installation on a circuit capable of delivering not more than 65kA (SCCR) symmetrical. 	<ul style="list-style-type: none"> Convient pour une installation de groupe moteur sur un circuit capable de délivrer pas plus de 65 kA rms symétriques.
<ul style="list-style-type: none"> These drives provide solid state motor overload protection at 125% of the rated FLA current. The drive overload trip point should not be set to less than 10% above the motor rated current: $AXIS\#.IL.FOLDFTHRESHU \geq 1.1 * AXIS\#.MOTOR.ICONT.$ 	<ul style="list-style-type: none"> Ces variateurs offrent une protection contre les surcharges de moteur à semi-conducteur à 125 % du courant FLA nominal. Le point de déclenchement en surcharge du variateur ne doit pas être réglé à moins de 10% au dessus du courant nominal du moteur: $AXIS\#.IL.FOLDFTHRESHU \geq 1,1 * AXIS\#.MOTOR.ICONT.$
<ul style="list-style-type: none"> These devices are intended to be used in a pollution degree 2 environment and must be placed in an enclosure with min. size of 16 x 16 x 10 inches 	<ul style="list-style-type: none"> Ces appareils sont prévus pour une utilisation dans un environnement de pollution de niveau 2 et doivent être placés dans une enceinte avec min. taille de 406 x 406 x 254 mm
<ul style="list-style-type: none"> Surrounding air temperature 40°C. Refer to chapter "Ambient Conditions", for other temperature ratings. 	<ul style="list-style-type: none"> La température de l'air ambiant 40 °C. Voir chapitre "Ambient Conditions", pour connaître les autres températures.
<ul style="list-style-type: none"> Use minimum 75°C copper wire. 	<ul style="list-style-type: none"> Utilisez un fil en cuivre 75 °C minimum.
<ul style="list-style-type: none"> Connector X3 torque requirements: <ul style="list-style-type: none"> - screw terminals, tightening torque 18 in-lbs - locking screw, tightening torque 3.5 in-lbs 	<ul style="list-style-type: none"> Exigences de couple du connecteur X3: <ul style="list-style-type: none"> - bornes à vis, couple de serrage 2 Nm - vis de blocage, couple de serrage 0,35 Nm
<ul style="list-style-type: none"> CAUTION Risk of Electrical Shock! Capacitors can have dangerous voltages present up to five minutes after switching off the supply power. For increased safety, measure the voltage in the DC bus link and wait until the voltage is below 50 V. 	<ul style="list-style-type: none"> ATTENTION: Risque de choc électrique! Des tensions dangereuses peuvent persister dans les condensateurs jusqu'à cinq minutes après la mise hors tension. Pour plus de sécurité, mesurez la tension dans la liaison de bus CC et attendez qu'elle soit inférieure à 50 V.

10.1.2 7V24S 24 A drives

This drive is listed under UL (Underwriters Laboratories Inc.) file number **E141084**.

USL, CNL - Power conversion equipment (NMMS, NMMS7)

USL (United States Standards - Listed): Indicates Investigated to United States Standard for Power Conversion Equipment, UL 61800-5-1.

CNL (Canadian National Standards - Listed): Indicates investigation to Canadian Standard for Industrial Control Equipment, CAN/CSA - C22.2, No. 274-17.

UL Markings / Marquages UL

English	Français
<ul style="list-style-type: none"> Integral solid state short circuit protection does not provide branch circuit protection. Branch circuit protection must be provided in accordance with the National Electrical Code and any additional local codes. 	<ul style="list-style-type: none"> Une protection de court-circuit à semi-conducteur intégrale ne fournit pas de protection de la dérivation. Il convient de garantir une protection de la dérivation conforme au NEC et aux réglementations locales en vigueur.
<ul style="list-style-type: none"> This product is suitable for use on a circuit capable of delivering not more than 10kA (SCCR) when protected by class J fuses or circuit breakers, and of delivering not more than 65kA (SCCR) when protected by semi-conductor fuses. 	<ul style="list-style-type: none"> Ce produit peut être utilisé sur un circuit capable de délivrer au maximum 10 kA (SCCR) lorsqu'il est protégé par des fusibles ou des disjoncteurs de classe J, et de délivrer au maximum 65 kA (SCCR) lorsqu'il est protégé par des fusibles à semi-conducteurs.
<ul style="list-style-type: none"> Suitable for motor group installation on a circuit capable of delivering not more than 10kA (SCCR) when protected by class J fuses or circuit breakers, and not more than 65kA (SCCR) when protected by semi-conductor fuses. 	<ul style="list-style-type: none"> Convient à l'installation d'un groupe de moteurs sur un circuit capable de délivrer au maximum 10 kA (SCCR) lorsqu'il est protégé par des fusibles ou des disjoncteurs de classe J, et au maximum 65 kA (SCCR) lorsqu'il est protégé par des fusibles à semi-conducteurs.
<ul style="list-style-type: none"> These drives provide solid state motor overload protection at 125% of the rated FLA current. The drive overload trip point should not be set to less than 10% above the motor rated current: $AXIS\#.IL.FOLDFTHRESHU \geq 1.1 * AXIS\#.MOTOR.ICONT.$ 	<ul style="list-style-type: none"> Ces variateurs offrent une protection contre les surcharges de moteur à semi-conducteur à 125 % du courant FLA nominal. Le point de déclenchement en surcharge du variateur ne doit pas être réglé à moins de 10 % au dessus du courant nominal du moteur: $AXIS\#.IL.FOLDFTHRESHU \geq 1,1 * AXIS\#.MOTOR.ICONT.$
<ul style="list-style-type: none"> These devices are intended to be used in a pollution degree 2 environment and must be placed in an enclosure with min. size of 600 x 600 x 350 mm 	<ul style="list-style-type: none"> Ces appareils sont prévus pour une utilisation dans un environnement de pollution de niveau 2 et doivent être placés dans une enceinte avec min. taille de 600 x 600 x 350 mm
<ul style="list-style-type: none"> Surrounding air temperature 40°C. Refer to chapter "Ambient Conditions", for other temperature ratings. 	<ul style="list-style-type: none"> La température de l'air ambiant 40 °C. Voir chapitre "Ambient Conditions", pour connaître les autres températures.
<ul style="list-style-type: none"> Use minimum 75°C copper wire. 	<ul style="list-style-type: none"> Utilisez un fil en cuivre 75 °C minimum.
<ul style="list-style-type: none"> Connector X3A/X3B torque requirements: <ul style="list-style-type: none"> - screw terminals, tightening torque 18 in-lbs - locking screw, tightening torque 3.5 in-lbs 	<ul style="list-style-type: none"> Exigences de couple du connecteur X3A/X3B: <ul style="list-style-type: none"> - bornes à vis, couple de serrage 2 Nm - vis de blocage, couple de serrage 0,35 Nm
<ul style="list-style-type: none"> CAUTION Risk of Electrical Shock! Capacitors can have dangerous voltages present up to five minutes after switching off the supply power. For increased safety, measure the voltage in the DC bus link and wait until the voltage is below 50 V. 	<ul style="list-style-type: none"> ATTENTION: Risque de choc électrique! Des tensions dangereuses peuvent persister dans les condensateurs jusqu'à cinq minutes après la mise hors tension. Pour plus de sécurité, mesurez la tension dans la liaison de bus CC et attendez qu'elle soit inférieure à 50 V.

10.2 Conformance with EU

NOTE

EU Declarations of Conformity can be found on the Kollmorgen website.

The drives have been tested by an authorized testing laboratory in a defined configuration, using the system components that are described in this documentation. Any divergence from the configuration and installation described in this documentation means that the user will be responsible for carrying out new measurements to ensure conformance with regulatory requirements.

Kollmorgen declares the conformity of the product series AKD2G with the following directives:

- EC Directive 2006/42/EU, Machinery Directive
Used harmonized standard EN 61800-5-2
- EC Directive 2014/35/EU, Low Voltage Directive
Used harmonized standard EN 61800-5-1
- EC Directive 2014/30/EU, EMC Directive
Used harmonized standard EN 61800-3

NOTICE

These devices can cause high-frequency interferences in non industrial environments and may require measures for interference suppression (such as additional external EMC filters).

Maximum distance for unshielded I/O lines is 3 m inside the cabinet. If the I/O cable leaves the cabinet, it must be EMC shielded.

AKD2G-Sxx-6Vxx

NOTE

AKD2G-Sxx-6Vxx drives do not have integrated ac line EMC filters. External mains filters are described in the *Accessories Manual* (1~: FN2090, 3~: FN3288).

With external EMC mains filters for noise emission the AKD2G-Sxx-6Vxx meet the noise immunity requirements of the second environmental category (industrial environment).

- Motor cable < 10 m: use filter FN 3288 in industrial environment, category C2.
- Motor cable ≥ 10 m: use filter FN 3288 in industrial environment, category C3.

AKD2G-Sxx-7Vxx

NOTE

AKD2G-Sxx-7Vxx drives have integrated EMC filters.

The AKD2G-Sxx-7Vxx meet the noise immunity requirements to the 2nd environmental category (industrial environment).

- AKD2G-Sxx-7V up to 12 Amps:
Motor cable < 10 m: no filter, in industrial environment, category C3.
Motor cable < 10 m: use filter FN 3288 in industrial environment, category C2.
Motor cable ≥ 10 m: use filter FN 3288 in industrial environment, category C3.
- AKD2G-Sxx-7V 24:
Motor cable < 10 m: no filter, in industrial environment, category C2.
Motor cable ≥ 10 m: no filter, in industrial environment, category C3.
Motor cable ≥ 10 m: use filter FN 3288 in industrial environment, category C2.

10.2.1 Functional Safety

NOTE

TÜV Certificate for Functional Safety can be found on the Kollmorgen website.

Kollmorgen offers 3 levels of functional safety implementation for AKD2G:

- Functional Safety Option 1: STO; SIL2 PLd , safe digital I/O command.
- Functional Safety Option 2: STO, SS1-t, SBC, SBT, SDB; SIL3 PLe , safe digital I/O command or FSoE.
- Functional Safety Option 3: STO, SS1-t, SS1-r, SS2, SOS, SLS, SSM, SSR, SDI, SLA, SAR, SLI, SLP, SCA, SBC, SDB, SBT; SIL3 PLe (→ # 203), safe digital I/O command or FSoE.

This manual is valid for AKD2G drives with Functional Safety Option 3.

10.2.2 Conformance with RoHS

The drives are manufactured in conformance with the Directive 2011/65/EU (RoHS), including Delegated Directive 2015/863/EU for installation into Finished Electrical and Electronic Equipment (EEE). One or more exemptions per Annex III of Directive 2011/65/EU may be applicable.

The conformity is only valid on the delivery date.

The chemical composition of the product may change due to environmental influences.

10.2.3 Conformance with REACH

REGULATION (EC) No 1907/2006 OF THE EUROPEAN PARLIAMENT AND OF THE COUNCIL as of 18 December 2006 concerning the Registration, Evaluation, Authorization and Restriction of Chemicals [REACH Regulations].

EU REACH Article 33 - Communication on SVHC identified in the Candidate List of Substances of Very High Concern (SVHC) for Authorisation.

Articles used in AKD2G drives may contain REACH SVHCs in concentrations above 0.1%.

Contact your Kollmorgen Sales Representative for the latest REACH SVHC information.

The conformity is only valid on the delivery date.

The chemical composition of the product may change due to environmental influences.

10.2.3.1 Waste Framework Directive Substances of Concern in Products (SCIP) Database

Standard Products constructed using Articles containing an SVHC in excess of 0.1% weight by weight, have been registered in the SCIP Database. SCIP Registration numbers for Standard Products can be found at [scip-database](#).

10.3 Conformance with UK

NOTE

Declarations of Conformity can be found on the Kollmorgen website.

NOTE

Kollmorgen declares the conformity of the product series with these regulations:

- S.I. 2008/1597, Supply of Machinery (Safety) Regulations 2008
 - Used designated standards EN 61800-5-2
- S.I. 2016/1101, Electrical Equipment (Safety) Regulations 2016
 - Used designated standard EN 61800-5-1
- S.I. 2016/1091, Electromagnetic Compatibility Regulations 2016
 - Used designated standard EN 61800-3

These products comply with **The Restriction of the Use of Certain Hazardous Substances in Electrical and Electronic Equipment Regulations 2012** for installation in a machine.

Kollmorgen authorized representative for UK government authority: Twiflex, Amphill Road, Bedford, MK42 9RD, UK

11 Index

A

Abbreviations	21, 197
Address	
Fieldbus	179
FSoE	180
MAC	179
SafelD	179
Service IP	179
AKD 2G Family	41
Ambient Conditions	43
Analog setpoints	164
Aux. supply 24V, interface	102

B

Brake Requirements (FS)	215
-------------------------------	-----

C

Cable and Wire Requirements	64
Cable Length	64
CANbus	
Baud rate	160
Cable	158
CANopen interface	158
Node address	160
Termination	160
Commissioning	201
Conformance	
CE	549
Functional Safety	549
REACH	550
RoHS	550
UK	550
UL, cUL	547
Connector Position	71

D

DC Bus Capacitance	50
DC bus link, interface	103
Decommission	32
Dimensions	57
Disassemble	32
Display	51
Disposal	34
Document revisions	553
DSL	109
Dynamic Drive Braking	49

E

EEO	151
Electronic Gearing	151
Emergency Off	28
Emergency Stop Function	28
Emulated Encoder Output	151

Enclosure (FS)	198
EtherCAT	155
EtherNet	
Modbus TCP Protocol	162
EtherNet Fieldbus	155
EtherNet/IP	157

F

Factory Defaults without FSoE	211
Fault messages	191
Feedback Connection	116
Feedback Requirements (FS)	216
Field replacement (FS)	310
FSoE Node Address	290
Functional Safety (FS)	193
Functional Safety 3 (FS3)	203
Fusing	
24V supply	103
Brake resistor	106
DC Bus Link	105
Mains supply	97

G

Grounding	62
Grounding Plates	71

H

Hardware requirements WorkBench	182
Hiperface DSL	109

I

I/O Connection	162
Initial Drive Test	178
Inputs	
Analog	164
Basic Data	163
Digital	166
Installation	
Electrical	60
Mechanical	56
Software WorkBench	183
Installation, Setup, Normal Operation	31
Instances	290

L

Leakage current	26
-----------------------	----

M

Mains supply, interface	91
Maintenance	32
Master-Slave	153
Mating Connectors	63
Mechanical Data	43
Modbus	162
Motor dual cable connection	110
Motor Holding Brake Connection	113

Motor interface	107	Service Interface	160
Motor single cable connection	108	Setup	177
N		Setup Software	181
Nameplate	37	SFA	137
O		SFD3	109
Operating systems WorkBench	182	Shield connection	67
Operation (FS)	309	Shielding	62
Operation States (FS)	310	Shock-hazard protection	26
OSSD	212	Site	43
Outputs		SS1-r	228
Analog	166	SS1-t	223
Basic Data	163	STO	219
Digital	171	Stop Function	28
Relay	175	Switch-on, switch-off behavior	183
P		Symbols used	19
Package supplied	37	T	
Part Number Scheme	37	Tightening torque	
PC connection	160	X1, X2	80
Product Safety	22	X23	87
PROFINET	156	X3	81
Prohibited Use		X3A	82
Functional Safety	196	X3B	82
General	25	X41	88
Pushbuttons	51	Trouble Shooting	192
R		U	
Re-forming	177	UL Markings	547-548
REACH	550	Update SMM Firmware	199
Regen circuit	49	Use as directed	
Regen resistor	106	Drive	25
Regeneration Braking	49	Functional Safety	196
Relay	175	WorkBench Setup Software	181
Repair	34	V	
RoHS	550	Validation (FS)	307
Rotary Switches	54	Ventilation	43
S		W	
SafelD	289	Warning Messages	191
Safety		Warning note labels	26
Functional Safety	193	Wiring	63
Product Safety	22	X	
Safety Faults	311	X23 / X41 Feedback Wiring Pinout Diagrams	124
Safety Instructions		X41 Feedback Wiring Pinout Diagrams	139
Drive Setup	177		
Electrical Installation	61		
General	23		
Mechanical Installation	57		
Safety Parameter Download	297		
Safety Properties	203		
Safety Warnings	311		
SBC	240		
SBT	249		
SD Card Slot	55		
SDB	255		

12 Record of Document Revisions

Edition	Remarks
...	Table with lifecycle information of this document (→ # 553)
A, 05/2021	First edition
B, 07/2022	SD Card text updated, Letter of Volatility link added, chapter "Shielding on drive" improved, Incr. Encoder feedback on X21 added, BiSS-C and SSI feedbacks on X41 (SFA) added, new motor connector image, chapter "Motion Bus interface" updated, PROFINET certified and available, chapter "Gearing" restructured, chapter "Feedback connector" restructured, SCCR rating for MV breaker changed, EtherNet/IP table updated, chapter "Mechanical Installation": Texts restructured and dimension table adapted, chapter "Mains supply": semi-conductor added, fusing chapter restructured, EAC approval removed, max. cable length per feedback type added, X23 feedback connector graphic expanded, conformity with UK added
C, 03/2024	7V24S drive contents added, including updated cover image, connector position image, general wiring diagrams, specifications and data, X3A and X3B connector content., individual X23 / X41 feedback wiring diagrams and specifications added, added connection to various mains supply network pages, limitations table edited, addition to part number scheme, corrected table formatting, added connector options availability table, added Projection of molten particles hazard warning, updated Safety Manual version compatibility table, updated AC and DC bus drive groupings to define number of axes limits, updated DIO X22 and X23 diagrams and bullets to better define termination and differential or single-ended options, updated 7V24S 24 A drives UL Approvals table to align with 65kA Certification, update EEO X22 diagrams.
D, 10/2024 (INTERNAL)	Removed content referring to DVD, new limitations for SMM1 and 2, new support page, wiring diagram corrected for drive test without load, addition to REACH and RoHS conformity
E, 02/2025	Note on mission time added to chapter "Disposal", removed content referring to DVD, new limitations for SMM1 and 2, new support page, wiring diagram corrected for drive test without load, addition to REACH and RoHS conformity

12.1 Limitations

SMM FW	Limitation	Remarks	Solved in SMM FW
02-07-000	Hiperface-DSL EFX50 encoders are not supported.	The EFX50 encoder series is not supported and phased out by Sick. Workaround: Use a more recent Hiperface-DSL encoder series.	-
02-07-000	Do not use FSoE Status Word bit "Error acknowledge status".	The status Word bit "Error acknowledge status" is set to true when either an I/O failure is detected, the safe encoder is not configured or the safe speed is not available. In case of an I/O failure, FSoE will send "FailSafeData" anyway. Therefore, this bit doesn't serve any purpose in real applications. Workaround: Check for I/O failures using the FSoE state instead of the Status Word.	-
02-07-000	Position monitoring limits have to be less than half of the max. position with SOS/SLI/SDI.	When using position monitoring with functions that use relative position (SOS/SLI/SDI), the position limit parameters (upper and lower) have to be less than half of the max. position of the encoder. Workaround: -	

SMM FW	Limitation	Remarks	Solved in SMM FW
02-07-000	Position monitoring limits have to be less than half of the max. position with SOS/SLI/SDI and signed-range.	<p>When using position monitoring with functions that use absolute position (SOS/SLI/SDI/), the position limit parameters (upper and lower) have to be less than half of the max. position of the encoder when using a signed range. For an unsigned range, the position limit parameters have to be less than the max. position of the encoder.</p> <p>Workaround: -</p>	
02-07-000	The deceleration ramp parameters for the safety functions SS1 (a_SS1), SS2 (a_SS2), SLS (a_SLS) and SSR (a_SSR) are using the defined velocity user unit per second instead of the defined acceleration user unit.	<p>Example:</p> <p>When the velocity user unit is rpm, the acceleration user unit is m/s² and a_SS1 is set to 1000, then the unit will be 1000 rpm/s instead of 1000 m/s².</p> <p>Workaround: -</p>	
02-07-000	Reset the absolute position when a safe encoder is physically replaced by another safe encoder.	<p>Reset the absolute position when:</p> <ul style="list-style-type: none"> • the safe encoder is physically replaced by another one (with the same or different model) and • the application is using at least one of the SLP or SCA instances (the application then requires a valid absolute position to operate). 	

Support and Services

About Kollmorgen

When you need motion and automation systems for your most demanding applications and environments, count on Kollmorgen - the innovation leader for more than 100 years. We deliver the industry's highest-performing, most reliable motors, drives, AGV control solutions and automation platforms, with over a million standard and easily modifiable products to meet virtually any motion challenge. We offer manufacturing facilities, distributors and engineering expertise in all major regions around the world, so you can bring a better machine to market faster and keep it profitable for many years to come.

Kollmorgen Developer Network



Join the [Kollmorgen Support Network](#) for product support. Ask the community questions, search the knowledge base for answers, get downloads, and suggest improvements.



Kollmorgen Support Locations

North America

Kollmorgen

201 West Rock Road
Radford, VA 24141, USA

Web: www.kollmorgen.com
Email: kollmorgen.support@regalrexnord.com
Tel.: +1-540-633-3545
Fax: +1-540-639-4162

Europe

Kollmorgen Europe GmbH

Pempelfurtstr. 1
40880 Ratingen, Germany

Web: www.kollmorgen.com
Email: Technical.Support.EU@regalrexnord.com
Tel.: +49-2102-9394-0
Fax: +49-2102-9394-3155

South America

Altra Industrial Motion do Brasil

Equipamentos Industriais LTDA.
Avenida João Paulo Ablas, 2970
Jardim da Glória, Cotia – SP
CEP 06711-250, Brazil

Web: www.kollmorgen.com
Email: kollmorgen.contato@regalrexnord.com
Tel.: (+55 11) 4615-6300

China and SEA

KOLLMORGEN

Room 302, Building 5, Libao Plaza,
88 Shenbin Road, Minhang District,
Shanghai, China.

Web: www.kollmorgen.cn
Email: Sales.China@regalrexnord.com
Tel.: +86-400 668 2802

KOLLMORGEN

A REGAL REYNORD BRAND