

AKD[®], AKD[®] BASIC, AKD[®] PDMM

Installation Manual



Edition: V, November 2015

Valid for AKD, AKD BASIC Hardware Revision E

Valid for AKD BASIC-I/O Hardware Revision EA

Valid for AKD PDMM Hardware Revision EB

Part Number 903-200003-00

Original Document



Keep all manuals as a product component during the life span of the product. Pass all manuals to future users and owners of the product.

KOLLMORGEN

Because Motion Matters™

Record of Document Revisions

Revision	Remarks
...	Table with lifecycle information of this document see (→ # 213)
T, 12/2014	48A drive information included, CE certificate removed, HR changed acc. to export control
U, 09/2015	EAC certification, 48A drive completed, RoHS/Reach chapters added, FPS added, connector voltage rating corrected, AKD 48A functional safety information, EnDAT 2.2 to X9&X8, KCM wiring corrected, note mains choke for 48A drive
V, 11/2015	Hall-Only Feedback new, hints for "User Guide" replaced by hints for Workbench Onlinehelp, Use as Directed (DC supply / grouping notes), safety standard corrected (EN 62061 for SIL)

Hardware Revision (HR)

AKD-B/P-NA	AKD-B/P-NB	AKD-M	AKD-T-IC	Firmware/Workbench	KAS IDE	Export Classification	Remarks
A	-	-	-	from 1.3	-	3A225	Start revision, export control
C	-	-	-	from 1.5	-	3A225	STO certified, PROFINET RT released, export control
-	D	DB	DA	from 1.6	from 2.5	3A225	Control board revision 9, AKD PDMM Start revision, AKD BASIC-IC Start revision, export control
D	E	EB	EA	from 1.13	from 2.9	-	Hardware revision for export classification traceability purposes

Trademarks

- AKD is a registered trademark of Kollmorgen Corporation
- EnDat is a registered trademark of Dr. Johannes Heidenhain GmbH
- EtherCAT is a registered trademark and patented technology, licensed by Beckhoff Automation GmbH
- Ethernet/IP is a registered trademark of ODVA, Inc.
- Ethernet/IP Communication Stack: copyright (c) 2009, Rockwell Automation
- sercos[®] is a registered trademark of sercos[®] international e.V.
- HIPERFACE is a registered trademark of Max Stegmann GmbH
- PROFINET is a registered trademark of PROFIBUS and PROFINET International (PI)
- SIMATIC is a registered trademark of SIEMENS AG
- Windows is a registered trademark of Microsoft Corporation

Current patents

- US Patent 5,162,798 (used in control card R/D)
- US Patent 5,646,496 (used in control card R/D and 1 Vp-p feedback interface)
- US Patent 6,118,241 (used in control card simple dynamic braking)
- US Patent 8,154,228 (Dynamic Braking For Electric Motors)
- US Patent 8,214,063 (Auto-tune of a Control System Based on Frequency Response)

Patents referring to fieldbus functions are listed in the matching fieldbus manual.

Technical changes which improve the performance of the device may be made without prior notice!

Printed in the United States of America

This document is the intellectual property of Kollmorgen. All rights reserved. No part of this work may be reproduced in any form (by photocopying, microfilm or any other method) or stored, processed, copied or distributed by electronic means without the written permission of Kollmorgen.

1 Table of Contents

1 Table of Contents	3
2 General	9
2.1 About this Installation Manual	10
2.2 Using the PDF Format	10
2.3 Symbols Used	11
2.4 Abbreviations Used	12
2.5 Standards Used	13
3 Safety	14
3.1 You should pay attention to this	15
3.2 Use as Directed	17
3.3 Prohibited Use	18
3.4 Handling	19
3.4.1 Transport	19
3.4.2 Packaging	19
3.4.3 Storage	19
3.4.4 Maintenance and Cleaning	20
3.4.5 Uninstalling	20
3.4.6 Repair and Disposal	20
4 Approvals	21
4.1 Conformance with UL/cUL	22
4.1.1 UL Markings / Marquages UL	22
4.2 Conformance with CE	24
4.2.1 European Directives and Standards for the Machine Builder	25
4.2.2 Conformance with RoHS	25
4.2.3 Conformance with REACH	25
4.3 Safe Torque Off (STO) approval	26
4.4 Conformance with EAC	26
5 Package	27
5.1 Package Supplied	28
5.2 Nameplate	28
5.3 Part Number Scheme	29
6 Technical description and data	30
6.1 The AKD Family of Digital Drives	31
6.2 Ambient Conditions, Ventilation, and Mounting Position	33
6.3 Mechanical Data	33
6.4 Inputs/Outputs	34
6.5 Electrical Data AKD-xzzz06	35
6.6 Electrical Data AKD-xzzz07	36
6.7 Performance Data	37
6.8 Recommended Tightening Torques	37
6.9 Grounding System	37
6.10 Fusing	38
6.10.1 External power supply fusing	38
6.10.2 External 24 V supply fusing	38
6.10.3 External regen resistor fusing	38
6.10.4 External DC Bus link fusing	38
6.11 Connectors	39
6.12 Cable and Wire Requirements	40
6.12.1 General	40
6.12.2 Cable cross sections and requirements	40

6.13	Dynamic Braking	41
6.13.1	Regen circuit	41
6.13.2	Functional description	41
6.13.3	Technical data for AKD-xzzz06	42
6.13.4	Technical data for AKD-xzzz07	43
6.14	Switch-On and Switch-Off Behavior	44
6.14.1	Switch-on behavior in standard operation	45
6.14.2	Switch-off behavior	46
6.14.2.1	Switch-off behavior using the DRV.DIS command	46
6.14.2.2	Switch-off behavior using a digital input (controlled stop)	47
6.14.2.3	Switch-off behavior using HW Enable input (uncontrolled stop)	47
6.14.2.4	Switch-off behavior in the event of a fault	48
6.15	Stop / Emergency Stop / Emergency Off	51
6.15.1	Stop	51
6.15.2	Emergency Stop	52
6.15.3	Emergency Off	52
6.16	Safe Torque Off (STO)	53
6.16.1	Safety characteristic data	53
6.16.2	Safety instructions	54
6.16.3	Use as directed	55
6.16.4	Prohibited use	55
6.16.5	Technical data and pinout	55
6.16.6	Enclosure, wiring	57
6.16.7	OSSD test pulses	57
6.16.8	Functional description	58
6.16.8.1	Signal diagram (sequence)	59
6.16.8.2	Wiring examples	60
6.16.8.3	Functional test	62
6.17	Shock-hazard Protection	64
6.17.1	Leakage current	64
6.17.2	Residual current protective device (RCD)	64
6.17.3	Isolating transformers	64
7	Mechanical Installation	65
7.1	Important Notes	66
7.2	Guide to Mechanical Installation	66
7.3	Mechanical Drawings Standard Width	67
7.3.1	Control cabinet layout AKD-xzzz06, standard width	67
7.3.2	Control cabinet layout AKD-xzzz07, standard width	68
7.3.3	Dimensions AKD-xzzz06, standard width	69
7.3.4	Dimensions AKD-xzzz07, standard width	70
7.4	Mechanical Drawings Extended Width	71
7.4.1	Control cabinet layout, example with AKD-M00306	71
7.4.2	Control cabinet layout, example with AKD-M00307	72
7.4.3	Dimensions AKD-xzzz06, extended width	73
7.4.4	Dimensions AKD-xzzz07, extended width	74
8	Electrical Installation	75
8.1	Important Notes	76
8.2	Guide to electrical installation	77
8.3	Wiring	78
8.4	Components of a servosystem	79
8.5	Connection Overview AKD-B, AKD-P, AKD-T	81
8.5.1	Connector assignment AKD-x00306, AKD-x00606	81
8.5.2	Connection diagram AKD-x00306, AKD-x00606	82
8.5.3	Connector assignment AKD-x01206	83

8.5.4 Connection diagram AKD-x01206	84
8.5.5 Connector assignment AKD-x02406 and AKD-x00307 to 02407	85
8.5.6 Connection diagram AKD-x02406 and AKD-x00307 to 02407	86
8.5.7 Connector assignment AKD-x04807	87
8.5.8 Connection diagram AKD-x04807	88
8.6 Connection Overview AKD-M	89
8.6.1 Connector assignment AKD-M00306, AKD-M00606	89
8.6.2 Connection diagram AKD-M00306, AKD-M00606	90
8.6.3 Connector assignment AKD-M01206	91
8.6.4 Connection diagram AKD-M01206	92
8.6.5 Connector assignment AKD-M02406, AKD-M00307 to AKD-M02407	93
8.6.6 Connection diagram AKD-M02406, AKD-M00307 to AKD-M02407	94
8.6.7 Connector assignment AKD-M04807	95
8.6.8 Connection diagram AKD-M04807	96
8.7 EMI Noise Reduction	97
8.7.1 Recommendations for EMI noise reduction	97
8.7.2 Shielding with external shielding busbar	98
8.7.2.1 Shielding Concept	98
8.7.2.2 Shielding Busbar	99
8.7.3 Shielding connection to the drive	100
8.7.3.1 Grounding plates	100
8.7.3.2 Shield connection clamps	100
8.7.3.3 Motor connector X2 with shielding connection	100
8.8 Electrical Supply Connection	101
8.8.1 Connection to various mains supply networks AKD-xzzz06 (120V to 240V)	101
8.8.2 Connection to various mains supply networks AKD-xzzz07 (240V to 480V)	102
8.8.3 24 V auxiliary supply (X1)	103
8.8.3.1 AKD-x003 to 024, connector X1	103
8.8.3.2 AKD-x048, connector X1	103
8.8.4 Mains supply connection (X3, X4)	104
8.8.4.1 Three phase connection (all AKD types)	105
8.8.4.2 Single/Dual phase connection (AKD-x00306 to AKD-x01206 only)	105
8.9 DC Bus link (X3, X14)	106
8.9.1 DC Bus topology with Y connectors (24 A max.)	107
8.9.2 DC Bus topology with busbar	107
8.9.3 External regen resistor (X3)	108
8.9.3.1 AKD-x003 to 024, regen connector X3	108
8.9.3.2 AKD-x048, regen connector X3	109
8.9.4 Capacitor Modules (X3)	110
8.9.4.1 Technical Data	110
8.9.4.2 Example installation with KCM-S and KCM-E	111
8.9.4.3 Example installation with KCM-P and KCM-E	112
8.9.4.4 Discharging KCM modules	113
8.10 Motor Power Connection (X2)	114
8.10.1 AKD-x003 to 024, power connector X2	115
8.10.2 AKD-x048, power connector X2	115
8.11 Motor Brake Connection (X2, X15, X16)	116
8.11.1 AKD-x003 to 024, brake connector X2	116
8.11.2 AKD-x048, brake connectors X15, X16	117
8.11.3 Functionality	118
8.12 Feedback Connection (X10, X9, X7)	119
8.12.1 Feedback connector (X10)	120
8.12.2 Feedback connector (X9)	121
8.12.3 Feedback connector (X7)	121

8.12.4 Resolver	122
8.12.5 SFD	123
8.12.6 SFD3	124
8.12.7 Hiperface DSL	125
8.12.8 Encoder with BiSS	126
8.12.8.1 BiSS (Mode B) analog	126
8.12.8.2 BiSS (Mode C) digital	127
8.12.9 Sine Encoder with EnDat 2.1	128
8.12.10 Encoder with EnDat 2.2	129
8.12.10.1 Connection to X10	129
8.12.10.2 Connection to X9 and X8	130
8.12.11 Sine Encoder with Hiperface	131
8.12.12 Sine Encoder	132
8.12.13 Incremental Encoder	133
8.12.14 Hall Sensors	134
8.12.15 Tamagawa Smart Abs Encoder	135
8.13 Electronic gearing, Master-slave operation (X9, X7)	136
8.13.1 Technical characteristics and pinout	136
8.13.1.1 Connector X7 Input	136
8.13.1.2 Connector X9 Input	137
8.13.1.3 Connector X9 Output	137
8.13.2 Command encoder signal connection	138
8.13.2.1 Incremental encoder input 5 V (X9)	138
8.13.2.2 Incremental encoder input 24 V (X7)	138
8.13.2.3 Encoder with EnDat 2.2 input 5 V (X9)	139
8.13.3 Pulse / Direction signal connection	140
8.13.3.1 Pulse / Direction input 5 V (X9)	140
8.13.3.2 Pulse / Direction Input 5 V to 24 V (X7)	140
8.13.4 CW / CCW signal connection	141
8.13.4.1 CW / CCW input 5 V (X9)	141
8.13.4.2 CW / CCW input 24 V (X7)	141
8.13.5 Emulated Encoder Output (EEO)	142
8.13.6 Master-Slave control	143
8.14 I/O Connection	144
8.14.1 Overview	144
8.14.1.1 I/O connectors X7 and X8 (all AKD variants)	144
8.14.1.2 I/O connectors X21, X22, X23 and X24 (AKD-T with I/O option card only)	145
8.14.1.3 I/O connectors X35 and X36 (AKD-M only)	147
8.14.2 Analog Input (X8, X24)	148
8.14.3 Analog Output (X8, X23)	149
8.14.4 Digital Inputs (X7/X8)	150
8.14.4.1 Digital Inputs 1 and 2	151
8.14.4.2 Digital Inputs 3 to 7	152
8.14.4.3 Digital Input 8 (ENABLE)	152
8.14.5 Digital Inputs with I/O option (X21, X22)	153
8.14.6 Digital Inputs (X35/X36) with AKD-M	155
8.14.7 Digital Outputs (X7/X8)	157
8.14.7.1 Digital Outputs 1 and 2	157
8.14.7.2 FAULT relay contacts	158
8.14.8 Digital Outputs with I/O option (X23/X24)	159
8.14.8.1 Digital Outputs 21 to 24, 26 to 29	159
8.14.8.2 Digital Relay Outputs 25, 30	160
8.14.9 Digital Outputs (X35/X36) with AKD-M	161
8.14.9.1 Digital Outputs 21 and 22	161

8.15	LED display	162
8.16	Rotary Switches (S1, S2, RS1)	163
8.16.1	Rotary switches S1 and S2 with AKD-B, -P, -T	163
8.16.2	Rotary switch RS1 with AKD-M	163
8.17	Pushbuttons (B1, B2, B3)	164
8.17.1	Pushbutton B1 with AKD-B, -P, -T	164
8.17.2	Pushbuttons B1, B2, B3 with AKD-M	165
8.18	SD Card Slot	166
8.18.1	SD Card Slot with I/O option card	166
8.18.2	SD Card Slot with AKD-M	167
8.19	Service Interface (X11, X32)	168
8.19.1	Pinout X11, X32	168
8.19.2	Service Bus Protocols X11, X32	168
8.19.3	Possible Network Configurations	168
8.19.4	Setting the IP Address AKD-B, AKD-P, AKD-T	169
8.19.5	Setting the IP Address AKD-M	171
8.19.6	Modbus TCP	172
8.20	CAN-Bus Interface (X12/X13)	172
8.20.1	CAN-Bus activation with AKD-CC models	173
8.20.2	Baud rate for CAN-Bus	174
8.20.3	Node Address for CAN-Bus	175
8.20.4	CAN-Bus Termination	175
8.20.5	CAN-Bus Cable	175
8.20.6	CAN-Bus Wiring	176
8.21	Motion Bus Interface (X5/X6/X11)	177
8.21.1	Pinout X5, X6, X11	177
8.21.2	Bus Protocols X5, X6, X11	177
8.21.3	EtherCAT	178
8.21.3.1	EtherCAT activation with AKD-CC models	178
8.21.4	SynqNet	179
8.21.5	PROFINET	179
8.21.6	Ethernet/IP	179
8.21.7	sercos® III	180
9	Setup	181
9.1	Important Notes	182
9.2	Setup AKD-B, AKD-P, AKD-T	183
9.2.1	Setup software WorkBench	183
9.2.2	Use as directed	183
9.2.3	Software description	184
9.2.4	Hardware requirements	184
9.2.5	Operating systems	184
9.2.6	Installation under Windows 2000/XP/VISTA/7	185
9.2.7	Initial Drive Test AKD-B, AKD-P, AKD-T	186
9.2.7.1	Unpacking, mounting, and wiring the AKD	186
9.2.7.2	Minimum wiring for drive test without load	186
9.2.7.3	Set IP address	187
9.2.7.4	Confirm connections	187
9.2.7.5	Install and start WorkBench	188
9.2.7.6	Set drive IP address in WorkBench	188
9.2.7.7	Enable the drive using the setup wizard	188
9.3	Setup AKD-M	189
9.3.1	Setup software KAS IDE	189
9.3.2	Use as directed	189
9.3.3	Software description	190

9.3.4 Hardware requirements	190
9.3.5 Operating systems	190
9.3.6 Installation under Windows XP/7	191
9.3.7 Initial Drive Test AKD-M	192
9.3.7.1 Unpacking, mounting, and wiring the AKD PDMM	192
9.3.7.2 Minimum wiring for drive test without load	192
9.3.7.3 Set IP address	193
9.3.7.4 Confirm connections	193
9.3.7.5 Install and start KAS IDE	194
9.3.7.6 Set drive IP address in KAS IDE	195
9.3.7.7 Starting new project	196
9.4 Fault and Warning Messages	199
9.4.1 Fault and warning messages AKD	199
9.4.2 Additional fault messages AKD-T	204
9.4.3 Additional error and alarm messages AKD-M	205
9.4.3.1 Alarms	205
9.4.3.2 Errors	206
9.5 Troubleshooting the AKD	207
10 Index	209
11 Record of document revisions	213

2 General

2.1 About this Installation Manual	10
2.2 Using the PDF Format	10
2.3 Symbols Used	11
2.4 Abbreviations Used	12
2.5 Standards Used	13

2.1 About this Installation Manual

This manual, *AKD Installation Manual* ("Instructions Manual" according to EC Machinery Directive 2006/42/EC), describes the AKD series of digital drives and includes information needed to safely install an AKD. A digital version of this installation manual (pdf format) is available on the DVD included with your drive. Manual updates can be downloaded from the Kollmorgen website (www.kollmorgen.com).

Additional documents include the following:

- *WorkBench Online Help*: describes how to use your drive in common applications. It also provides tips for maximizing your system performance with the AKD. The *Online Help* includes the *Parameter and Command Reference Guide* which provides information for the parameters and commands used to program the AKD.
- *CAN-BUS Communication*: describes how to use your drive in CANopen applications.
- *EtherCAT Communication*: describes how to use your drive in EtherCAT applications.
- *Ethernet/IP Communication*: describes how to use your drive in Ethernet/IP applications.
- *sercos[®] III Communication*: describes how to use your drive in sercos[®] applications.
- *PROFINET RT Communication*: describes how to use your drive in PROFINET RT applications.
- *SynqNet Communication*: describes how to use your drive in SynqNet applications.
- *Accessories Manual*. It provides information for accessories like cables and regen resistors used with AKD. Regional variants of this manual exist.







2.2 Using the PDF Format

This document includes several features for ease of navigation











Cross References	Table of contents and index include active cross references.
Table of contents and index	Lines are active cross references. Click on the line and the appropriate page is accessed.
Page/chapter numbers in the text	Page/chapter numbers with cross references are active links.

2.3 Symbols Used

Warning Symbols

Symbol	Indication
 DANGER	Indicates a hazardous situation which, if not avoided, will result in death or serious injury.
 WARNING	Indicates a hazardous situation which, if not avoided, could result in death or serious injury.
 CAUTION	Indicates a hazardous situation which, if not avoided, could result in minor or moderate injury.
NOTICE	Indicates situations which, if not avoided, could result in property damage.
NOTE	This symbol indicates important notes.
	Warning of a danger (general). The type of danger is specified by the text next to the symbol.
	Warning of danger from electricity and its effects.
	Warning of danger from hot surface.
	Warning of suspended loads.

Drawing symbols

Symbol	Description	Symbol	Description
	Signal ground		Diode
	Chassis ground		Relay
	Protective earth		Relay switch off delayed
	Resistor		Normally open contact
	Fuse		Normally closed contact

2.4 Abbreviations Used

Abbreviation	Meaning
(→ # 53)	"see page 53" in this document
AGND	Analog ground
CE	Communauté Européenne
COM	Serial interface for a personal computer
DCOMx	Communication line for digital inputs (with x=7 or 8)
Disk	Magnetic storage (diskette, hard disk)
EEPROM	Electrically erasable programmable memory
EMC	Electromagnetic compatibility
F-SMA	Fiber optic cable connector according to IEC 60874-2
KAS	Kollmorgen Automation Suite
KAS IDE	Setup software (Kollmorgen Automation Suite Integrated Development Environment) used for AKD PDMM drives
LED	Light-emitting diode
LSB	Low significant byte (or bit)
MSB	Main significant byte (or bit)
NI	Zero pulse
PC	Personal computer
PE	Protective earth
PLC	Programmable logic control
PWM	Pulse-width modulation
RAM	Random access memory (volatile memory)
$R_{\text{Brake}}/R_{\text{B}}$	Regen resistor (also called a brake resistor)
RBext	External regen resistor
RBint	Internal regen resistor
RCD	Residual current device
RES	Resolver
ROD	Incremental encoder (A quad B)
S1	Continuous operation
STO	Safe torque off
VAC	Volts, alternating current
VDC	Volts, direct current

2.5 Standards Used

Standard	Content
ISO 4762	Hexagon socket head cap screws
ISO 11898	Road vehicles — Controller area network (CAN)
ISO 12100	Safety of machinery: Basic concepts, general principles for design
ISO 13849	Safety of machinery: Safety-related parts of control systems
IEC 60085	Electrical insulation - Thermal evaluation and designation Maintenance
IEC 60204	Safety of Machinery: Electrical equipment of machinery
IEC 60364	Low-voltage electrical installations
IEC 60439	Low-Voltage Switchgear and Controlgear Assemblies
IEC 60529	International protection rating (IP code)
IEC 60664	Insulation coordination for equipment within low-voltage systems
IEC 60721	Classification of environmental conditions
IEC 61000	Electromagnetic compatibility (EMC)
IEC 61131	Programmable controllers
IEC 61491	Electrical equipment of industrial machines – Serial data link for real-time communications between controls and drives.
IEC 61508	Functional safety of electrical/electronic/programmable electronic safety-related systems
IEC 61800	Adjustable speed electrical power drive systems
IEC 62061	Functional safety of electrical/electronic/programmable electronic safety-related systems
IEC 82079	Preparation of instructions for use - Structuring, content and presentation
UL 840	UL Standard for Safety for Insulation Coordination Including Clearances and Creepage Distances for Electrical Equipment
UL 508C	UL Standard for Safety Power Conversion Equipment

IEC - International Electrotechnical Commission

ISO - International Organization for Standardization

UL - Underwriters Laboratories

3 Safety

3.1 You should pay attention to this	15
3.2 Use as Directed	17
3.3 Prohibited Use	18
3.4 Handling	19

3.1 You should pay attention to this

This section helps you to recognize and avoid dangers to people and objects.

Specialist staff required!

Only properly qualified personnel are permitted to perform such tasks as transport, assembly, setup and maintenance. Qualified specialist staff are persons who are familiar with the transport, installation, assembly, commissioning and operation of drives and who bring their relevant minimum qualifications to bear on their duties:

- Transport: only by personnel with knowledge of handling electrostatically sensitive components.
- Unpacking: only by electrically qualified personnel.
- Installation: only by electrically qualified personnel.
- Basic tests / Setup: only by qualified personnel with knowledge of electrical engineering and drive technology

The qualified personnel must know and observe ISO 12100 / IEC 60364 / IEC 60664 and national accident prevention regulations.

Read the documentation!

Read the available documentation before installation and commissioning. Improper handling of the drive can cause harm to people or damage to property. The operator of systems using the AKD must require that all personnel who work with the drive read and understand the manual before using the drive.

Check Hardware Revision!

Check the Hardware Revision Number of the product (see product label). This number is the link between your product and the manual, it must match the Hardware Revision Number on the cover page of the manual.

Pay attention to the technical data!

Adhere to the technical data and the specifications on connection conditions (rating plate and documentation). If permissible voltage values or current values are exceeded, the drives can be damaged.

Perform a risk assessment!

The manufacturer of the machine must generate a risk assessment for the machine, and take appropriate measures to ensure that unforeseen movements cannot cause injury or damage to any person or property. Additional requirements on specialist staff may also result from the risk assessment.

Automatic Restart!



The drive might restart automatically after power on, voltage dip or interruption of the supply voltage, depending on the parameter setting. Risk of death or serious injury for humans working in the machine.

If the parameter DRV.ENDEFAULT is set to 1, then place a warning sign to the machine (Warning: Automatic Restart at Power On) and ensure, that power on is not possible, while humans are in a dangerous zone of the machine. In case of using an undervoltage protection device, you must observe EN 60204-1:2006 chapter 7.5 .

Observe electrostatically sensitive components!

The drives contain electrostatically sensitive components which may be damaged by incorrect handling. Electrostatically discharge your body before touching the drive. Avoid contact with highly insulating materials (artificial fabrics, plastic film etc.). Place the drive on a conductive surface.

Hot surface!

Drives may have hot surfaces during operation. The heat sink can reach temperatures above 80°C. Risk of minor burns! Measure the temperature, and wait until the heat sink has cooled down below 40 °C before touching it.

**Earthing!**

It is vital that you ensure that the drive is safely earthed to the PE (protective earth) busbar in the switch cabinet. Risk of electric shock. Without low-resistance earthing no personal protection can be guaranteed.

**High voltages!**

The equipment produces high electric voltages up to 900V. Risk of electric shock. Do not open or touch the equipment during operation. Keep all covers and cabinet doors closed. During operation, drives may have uncovered live sections, according to their level of enclosure protection. Wait at least seven minutes after disconnecting the drive from the main supply power before touching potentially live sections of the equipment (such as contacts) or removing any connections.

Capacitors can have dangerous voltages present up to seven minutes after switching off the supply power. Always measure the voltage in the DC bus link and wait until the voltage is below 50 V before handling components.

Never undo any electrical connections to the drive while it is live. There is a danger of electrical arcing with damage to contacts and personal injury.

Reinforced Insulation

Thermal sensors, motor holding brakes and feedback systems built into the connected motor must have reinforced insulation (according to IEC61800-5-1) against system components with power voltage, according to the required application test voltage. All Kollmorgen components meet these requirements.

Never modify the drive!

It is not allowed to modify the drive without permission by the manufacturer. Opening the housing causes loss of warranty.



3.2 Use as Directed

The AKD drives are exclusively intended for driving suitable synchronous servomotors with closed-loop control of torque, speed, and/or position.

AKDs are components that are built into electrical plants or machines and can only be operated as integral components of these plants or machines. The manufacturer of the machine used with a drive must generate a risk assessment for the machine. When the drives are built into machines or plant, the drive must not be used until it has been established that the machine or plant fulfills the requirements of the regional directives.

Cabinet and wiring

Drives must only be operated in a closed control cabinet suitable for the ambient conditions (→ # 30). Ventilation or cooling may be necessary to keep the temperature within the cabinet below 40 °C.

Use only copper conductors for wiring. The conductor cross-sections can be derived from the standard IEC 60204 (alternatively for AWG cross-sections: NEC Table 310-16, 75 °C column).

Power supply

The drives can be supplied by 1 or 3 phase industrial supply networks.

Drives in the AKD series can be supplied as follows:

- AKD-xzzz06: 1 or 3 phase industrial supply networks
(not more than 200 kA symmetrical rated current at 120 V and 240 V).
- AKD-xzzz07: 3 phase industrial supply networks
(not more than 200 kA symmetrical rated current at 240 V, 400 V and 480 V).

Connection to other voltage types of supply networks is possible with an additional isolating transformer (→ # 101).

AKD-x04807: In case of mains voltage asymmetry >3% a mains choke 3L0,24-50-2 must be used.

Periodic overvoltages between phases (L1, L2, L3) and the housing of the drive must not exceed 1000 V peak. In accordance with IEC 61800, voltage spikes (< 50 µs) between phases must not exceed 1000 V. Voltage spikes (< 50 µs) between a phase and the housing must not exceed 2000 V.

EMC filter measures for AKD-xzzz06 must be implemented by the user.

For the cases of group installations and of DC powered drives

NOTE

AKD has not been evaluated by Kollmorgen, UL, or TÜV for group installations nor are ratings defined for DC input voltage.

Group installations must be reviewed and evaluated by the user for branch circuit protection*, wire size, wire voltage rating, fuse protection, system dielectric requirements, overvoltage and input** current rating.

In case of DC supplied drives the built-in EMC filter will not work. The user is responsible to keep the conducted emissions and the immunity of the drive within the required noise levels.

* Special care must be taken in branch circuit design with mixed rating drives to avoid the smaller drives becoming the effective 'fuse' rather than the circuit protective fuse.

** The power supply system design must ensure inrush current protection by limiting input current during power up. DC supply polarity must be properly wired. Improper polarity of DC power will damage the drive and void warranty.

Motor voltage rating

The rated voltage of the motors must be at least as high as the DC bus link voltage divided by $\sqrt{2}$ produced by the drive ($U_{nMotor} \geq U_{DC} / \sqrt{2}$).

Safe torque off

Review the section "Use as Directed" in the STO chapter (→ # 55) before using this safety function (according to ISO 13849 category 3).

3.3 Prohibited Use

Other use than that described in chapter "Use as directed" is not intended and can lead to personnel injuries and equipment damage. The drive may not be used with a machine that does not comply with appropriate national directives or standards. The use of the drive in the following environments is also prohibited:

- potentially explosive areas
- environments with corrosive and/or electrically conductive acids, alkaline solutions, oils, vapors, dusts
- ships or offshore applications

3.4 Handling

3.4.1 Transport

Transport the AKD in accordance with IEC 61800-2 as follows:

- Transport only by qualified personnel in the manufacturer's original recyclable packaging. Avoid shocks while transporting.
- Store at or below maximum stacking height, details see "Storage" (→ # 19)
- Transport only within specified temperature ranges: -25 to +70 °C, max. rate of change 20 K/hour, class 2K3.
- Transport only within specified humidity: max. 95% relative humidity, no condensation, class 2K3.

NOTICE

The drives contain electrostatically sensitive components that can be damaged by incorrect handling. Electrostatically discharge yourself before touching the drive. Avoid contact with highly insulating materials, such as artificial fabrics and plastic films. Place the drive on a conductive surface.

If the packaging is damaged, check the unit for visible damage. Inform the shipper and the manufacturer of any damage to the package or product.

3.4.2 Packaging

The AKD packaging consists of recyclable cardboard with inserts and a label on the outside of the box.

Model	Package Dimensions (mm) HxWxL	Total Weight AKD-B, -P, -T (kg)	Total Weight AKD-M (kg)
up to AKD-x00606	113 x 250 x 222	1.7	1.9
AKD-x01206	158 x 394 x 292	3.4	3.6
AKD-x02406	158 x 394 x 292	5	5.2
AKD-x00307 and AKD-x00607	158 x 394 x 292	4.3	4.5
AKD-x01207	158 x 394 x 292	4.3	4.5
AKD-x02407	158 x 394 x 292	6.7	6.9
AKD-x04807	390 x 600 x 400	15.3	15.5

3.4.3 Storage

Store the AKD in accordance with IEC 61800-2 as follows:

- Store only in the manufacturer's original recyclable packaging.
- Store at or below maximum stacking height :
 - AKD-x00306 to 00606 models: 8 cartons,
 - AKD-x01206, x02406, x00307 to x02407 models: 6 cartons,
 - AKD-x04807 models: 3 cartons.
- Store only within specified temperature ranges: -25 to +55 °C, max.rate of change 20 K/hour, class 1K4.
- Storage only within specified humidity: 5 to 95% relative humidity, no condensation, class 1K3.
- Store in accordance with the following duration requirements:
 - Less than 1 year: without restriction.
 - More than 1 year: capacitors must be re-formed before setting up and operating the drive. Re-forming procedures are described in the Kollmorgen Developer Network ([Forming](#)).

3.4.4 Maintenance and Cleaning

The drive does not require maintenance. Opening the drive voids the warranty.

The inside of the unit can only be cleaned by the manufacturer. To clean the drive exterior:

- Casing: Clean with isopropanol or similar cleaning solution.
- Protective grill on fan: Clean with a dry brush.

NOTICE

Do not immerse or spray the drive.

3.4.5 Uninstalling

If a drive must be uninstalled (such as for replacement), remove the drive as follows:

1. Switch off the main switch of the switchgear cabinet and the fuses that supply the system.



WARNING

Contacts can still have dangerous voltage present up to seven minutes after switching off mains voltage. Risk of electrical shock! Wait at least seven minutes after disconnecting the drive from the main supply power before touching potentially live sections of the equipment (e.g. contacts) or undoing any connections. Always measure the voltage in the DC bus link and wait until the voltage is below 50 V before touching or handling the drive.

2. Remove the connectors. Disconnect the potential earth connection last.
3. Check temperature.



CAUTION

During operation, the heat sink of the drive may reach temperatures above 80 °C (176 °F). Risk of minor burns. Before touching the device, check the temperature and wait until it has cooled below 40 °C (104 °F).

4. Uninstall. Remove the drive and power supply from the conductive, grounded mounting plate in the cabinet.

3.4.6 Repair and Disposal

Only the manufacturer can repair the drive. Opening the device voids the warranty. Uninstall the drive as described in (→ # 20), then send the drive in the original packaging to the manufacturer (see table below).

In accordance with the WEEE-2002/96/EC-Guidelines and similar, the manufacturer accepts returns of old devices and accessories for professional disposal. Transport costs are the responsibility of the sender. Send the devices to the manufacturer addresses shown in the table below.

USA	Europe
Kollmorgen 201 West Rock Road Radford, VA 24141	KOLLMORGEN Europe GmbH Pempelfurtstr. 1 D-40880 Ratingen

4 Approvals

4.1	Conformance with UL/cUL	22
4.2	Conformance with CE	24
4.3	Safe Torque Off (STO) approval	26
4.4	Conformance with EAC	26

4.1 Conformance with UL/cUL

This drive is listed under UL (Underwriters Laboratories Inc.) file number **E141084** Vol.3 Sec.5.

USL, CNL – Power conversion equipment (NMMS, NMMS7) – Models AKD followed by B, P, T or M, followed by 003, 006, 012, 024 and 048, followed by 06 or 07, followed by additional suffixes.

USL (United States Standards - Listed): Indicates Investigated to United States Standard for Power Conversion Equipment, UL 508C.

CNL (Canadian National Standards - Listed): Indicates investigation to Canadian Standard for Industrial Control Equipment, CAN/CSA - C22.2, No. 14-13.

4.1.1 UL Markings / Marquages UL

English	Français
<ul style="list-style-type: none"> Identification of the terminals on the controller are coded so they may be identified in the instructions. The instructions shall identify power connections for power supply, load, control, and ground. 	<ul style="list-style-type: none"> Les bornes de l'unité de contrôle sont codées pour faciliter leur identification dans les instructions. Les instructions doivent identifier les raccordements d'alimentation, de charge, de commande et de terre.
<ul style="list-style-type: none"> Integral solid state short circuit protection does not provide branch circuit protection. Branch circuit protection must be provided in accordance with the National Electrical Code and any additional local codes. 	<ul style="list-style-type: none"> Une protection de court-circuit à semi-conducteur intégrale ne fournit pas de protection de la dérivation. Il convient de garantir une protection de la dérivation conforme au NEC (National Electrical Code) et aux réglementations locales en vigueur, ou aux directives équivalentes applicables.
<ul style="list-style-type: none"> This product is suitable for use on a circuit capable of delivering not more than 200,000 rms symmetrical amperes, 240 V (AKD-xzzz06) / 480 V (AKD-xzzz07) volts maximum, when protected by fuses. 	<ul style="list-style-type: none"> Ce produit est conçu pour une utilisation sur un circuit capable de fournir 200 000 ampères symétriques (rms) maximum pour 240 V (AKD-xzzz06) / 480 V (AKD-xzzz07) maximum, s'il dispose de fusibles ou de protections équivalentes.
<ul style="list-style-type: none"> These drives provide solid state motor overload protection at 125% of the rated FLA Current. 	<ul style="list-style-type: none"> Ces variateurs offrent une protection contre les surcharges de moteur à semi-conducteur à 125 % du courant FLA nominal.
<ul style="list-style-type: none"> These devices are intended to be used in a pollution degree 2 environment. 	<ul style="list-style-type: none"> Ces appareils sont prévus pour une utilisation dans un environnement de pollution de niveau 2.
<ul style="list-style-type: none"> Maximum surrounding air temperature of 40°C. 	<ul style="list-style-type: none"> La température de l'air ambiant doit être de 40 °C maximum ou une valeur équivalente.
<ul style="list-style-type: none"> Use minimum 75°C copper wire. 	<ul style="list-style-type: none"> Utilisez un fil en cuivre 75 °C minimum.
<ul style="list-style-type: none"> These devices do not provide over temperature sensing. 	<ul style="list-style-type: none"> Ces variateurs n'offrent pas de capteurs de température excessive.
<ul style="list-style-type: none"> Use fuses only. 	<ul style="list-style-type: none"> Utilisez uniquement des fusibles.
<ul style="list-style-type: none"> CAUTION Risk of Electrical Shock! Capacitors can have dangerous voltages present up to seven minutes after switching off the supply power. For increased safety, measure the voltage in the DC bus link and wait until the voltage is below 50 V. 	<ul style="list-style-type: none"> ATTENTION: Risque de choc électrique! Des tensions dangereuses peuvent persister dans les condensateurs jusqu'à sept minutes après la mise hors tension. Pour plus de sécurité, mesurez la tension dans la liaison de bus CC et attendez qu'elle soit inférieure à 50 V.

- The following fuse types are recommended /
Les types de fusibles suivants sont recommandés :

Model Modèle	Class/ Classe	Rating/ Niveau	Max. Fuse Rating/ Niveau maximum
AKD-x00306	J	600 VAC, 200 kA	10 A
AKD-x00606	J	600 VAC, 200 kA	15 A
AKD-x01206	J	600 VAC, 200 kA	15 A
AKD-x02406	J	600 VAC, 200 kA	30 A
AKD-x00307	J	600 VAC, 200 kA	6 A
AKD-x00607	J	600 VAC, 200 kA	10 A
AKD-x01207	J	600 VAC, 200 kA	15 A
AKD-x02407	J	600 VAC, 200 kA	30 A
AKD-x04807	J	600 VAC, 200 kA	60 A

- The following table illustrates the torque requirements for the field wiring connectors /
Le tableau suivant indique les spécifications de couple pour les connecteurs de câblage sur site:

Model/ Modèle	Mains Connector/ Connecteur secteur	Motor Phase Connector/ Con- necteur de phase moteur	24 VDC Input Connector/ Con- necteur d'entrée 24Vcc
AKD-x00306	5-7 in-lbs	5-7 in-lbs	4 in-lbs
AKD-x00606	5-7 in-lbs	5-7 in-lbs	4 in-lbs
AKD-x01206	5-7 in-lbs	7 in-lbs	4 in-lbs
AKD-x02406	7 in-lbs	7 in-lbs	4 in-lbs
AKD-x00307	7 in-lbs	7 in-lbs	4 in-lbs
AKD-x00607	7 in-lbs	7 in-lbs	4 in-lbs
AKD-x01207	7 in-lbs	7 in-lbs	4 in-lbs
AKD-x02407	7 in-lbs	7 in-lbs	4 in-lbs
AKD-x04807	13 in-lbs	13 in-lbs	4 in-lbs

4.2 Conformance with CE

Conformance with the EC EMC Directive 2004/108/EC and the Low Voltage Directive 2006/95/EC is mandatory for the supply of drives within the European Community.

NOTE

CE Declarations of Conformity can be found on the Kollmorgen website.

The drives have been tested by an authorized testing laboratory in a defined configuration, using the system components that are described in this documentation. Any divergence from the configuration and installation described in this documentation means that the user will be responsible for carrying out new measurements to ensure conformance with regulatory requirements.

Kollmorgen declares the conformity of the product series AKD with the following directives:

- EC Directive 2006/42/EC, Machinery Directive
Used harmonized standard EN61800-5-2 (2007)
- EC Directive 2006/95/EC, Low Voltage Directive
Used harmonized standard EN61800-5-1 (2007)
- EC Directive 2004/108/EC, EMC Directive
Used harmonized standard EN 61800-3 (2004)

NOTICE

These devices can cause high-frequency interferences in non industrial environments and may require measures for interference suppression (such as additional external EMC filters).

AKD-xzzz06

NOTE

AKD-xzzz06 drives do not have integrated EMC filters.

With external EMC filters for noise emission the AKD-xzzz06 meet the noise immunity requirements of the second environmental category (industrial environment) to a product of the category C2 (motor cable < 10 m).

With a motor cable length of 10 m or longer and external EMC filters, the AKD-xzzz06 meet the requirement of category C3.

AKD-xzzz07

NOTE

AKD-xzzz07 drives have integrated EMC filters.

The AKD-xzzz07 meet the noise immunity requirements to the 2nd environmental category (industrial environment). For noise emission the AKD-xzzz07 meet the requirement to a product of the Category C2 (motor cable < 10 m).

With a motor cable length of 10 m or longer, the AKD-xzzz07 meet the requirement to the Category C3.

AKD-x04807: In case of mains voltage asymmetry >3% a mains choke 3L0,24-50-2 must be used.

4.2.1 European Directives and Standards for the Machine Builder

Drives are components that are intended to be incorporated into electrical plant and machines for industrial use. When the drives are built into machines or plant, the drive must not be used until it has been established that the machine or equipment fulfills the requirements of the

- EC Machinery Directive (2006/42/EC)
- EC EMC Directive (2004/108/EC)
- EC Low Voltage Directive (2006/95/EC)

Standards to be applied for conformance with the EC Machinery Directive (2006/42/EC)

- IEC 60204-1 (Safety and Electrical Equipment in Machines)
- ISO 12100 (Safety of Machines)

NOTICE

The manufacturer of the machine must generate a risk assessment for the machine, and must implement appropriate measures to ensure that unforeseen movements cannot cause injury or damage to any person or property.

Standards to be applied for conformance with the EC Low Voltage Directive(2006/95/EC)

- IEC 60204-1 (Safety and Electrical Equipment in Machines)
- IEC 60439-1 (Low-voltage switchgear and controlgear assemblies)

Standards to be applied for conformance with the EC EMC Directive (2004/108/EC)

- IEC 61000-6-1/2 (Interference Immunity in Residential & Industrial Areas)
- IEC 61000-6-3/4 (Interference Generation in Residential & Industrial Areas)

The manufacturer of the machine/plant is responsible for ensuring that it meets the limits required by the EMC regulations. Advice on the correct installation for EMC (such as shielding, grounding, treatment of connectors and cable layout) is shown in this manual.

NOTE

The machine/plant manufacturer must check whether other standards or EC Directives must be applied to the machine/plant.

Kollmorgen only guarantees the conformance of the servosystem with the standards cited in this chapter if the components (motor, cables, chokes etc.) are those supplied by Kollmorgen.

4.2.2 Conformance with RoHS

Directive 2011/65/EC of the European Union on the restriction of the use of certain hazardous substances in electrical and electronic equipment (RoHS) became operative as from the 3rd of January, 2013. Following substances namely are involved

Lead (Pb), Cadmium (Cd), Hexavalent chromium (CrVI), Polybrominated biphenyls (PBB), Polybrominated diphenyl ethers (PBDE), Mercury (Hg)

The AKD drive series is manufactured RoHS conformal.

4.2.3 Conformance with REACH

EU Regulation no. 1907/2006 deals with the registration, evaluation, authorization and restriction of chemical substances 1 (abbreviated to "REACH").

AKD does not contain any substances (CMR substances, PBTsubstances, vPvB substances and similar hazardous substances stipulated in individual cases based on scientific criteria) above 0.1 mass percent per product that are included on the candidate list.

4.3 Safe Torque Off (STO) approval

An additional digital input (STO, **Safe Torque Off**) releases the power output stage of the drive as long as a 24 V signal is applied to this input. If the STO input goes open-circuit, then power will no longer be supplied to the motor, and the drive will lose all torque and coast to a stop.

The STO safety implementation on the AKD is certified. The safety circuit implementation for realizing the safety function "Safe Torque Off" in the drive is suited for SIL2 according to IEC 62061 and PLd, Cat.3 according to ISO 13849-1.

With AKD-x04807 drives SIL3/PLe is possible, if both STO-Enable inputs are used with the corresponding STO-Status signals.

NOTE

Safety certificates can be found on the Kollmorgen website.

The subsystems (AKD) are totally described for safety technics with the characteristic data :

Device	Operation Mode	ISO 13849-1	IEC 62061	PFH [1/h]	T _M [Years]	SFF [%]
AKD-x003...024	single channel	PL d, CAT 3	SIL 2	0	20	100
AKD-x048	single channel	PL d, CAT 2	SIL 2	1.88E-07	20	89
	dual channel	PL d, CAT 3	SIL 2	5.64E-09	20	87
	dual channel with periodical testing	PL e, CAT 4	SIL 3	5.64E-09	20	87

4.4 Conformance with EAC

EAC is the abbreviation for Eurasian Conformity. The mark is used in the states of the Eurasian Customs Union (Russia, Belarus, Kazakhstan) similar to the European CE mark.

Kollmorgen declares, that the AKD has passed all required conformity procedures in a member state of the Eurasian Customs Union, and that the AKD meets all technical requirements requested in the member states of the Eurasian Customs Union:

- Low voltage (TP TC 020/2011)
- Electromagnetic Compatibility (TP TC 004/2011)

Contact:

Intelligence Automatics LLC. , Bakuninskaya Str. d 14, Building 1, RU-105005 Moskau

5 Package

5.1 Package Supplied	28
5.2 Nameplate	28
5.3 Part Number Scheme	29

5.1 Package Supplied

When a drive from the AKD series is ordered, the following items are included in the drive package:

- AKD
- Printed copy of *AKD Safety Guide*
- Printed copy of *AKD Quick Start* and *AKD Fault Card* (not in EU)
- DVD containing the *AKD Installation Manual*, all fieldbus manuals, the setup software WorkBench, and more product documentation in digital format.
- Mating connectors (if required for the drive variant): X1, X2, X3, X4, X7, X8, X14, X15, X16, X21, X22, X23, X24, X35, X36
- Grounding plate, with AKD voltage type 07, with voltage type 06 for EU only

NOTE

The mating SubD and RJ45 connectors are not included in the package.







Accessories Sold Separately

Accessories must be ordered separately if required; refer to your regional accessories manual:

- EMC filters for 24 V and mains supply voltage, categories C2 or C3
- External regen resistor
- Motor cable. Assembled motor cables are available for all regions.
- Feedback cable. Assembled feedback cables are available for all regions.
- Motor choke, for motor cables longer than 25 m
- CAN termination connector (with CAN drives only)
- Service cable to the network
- Power cable, control cables, and fieldbus cables (as cutoff lengths)

5.2 Nameplate

The nameplate depicted below is attached to the side of the drive, sample data entries are for a 12 A type.

KOLLMORGEN		Customer Support: North America: +1 (540) 633-3400 Europe: +49 (0) 203-89790 Italy: +39 (0) 362-594260	HW Rev: E 
201 W. Rock Road Radford, VA 24141			
Model No:	AKD-P01207-NBCN-0000 		
Serial No:	R-0912-00001 		
MAC Address:	00-23-1B-DF-88-AA		
	INPUT	OUTPUT	   
Voltage	480 Vac	0-480 Vac	
Frequency	50/60 Hz	0-600 Hz	
Phase	3 Ph	3 Ph	
FL Current	9.2 Arms	12 Arms	
Power @ 480 Vac	7.65 kVA		
Enclosure Protection Rating:		IP20	
Before use, refer to CD for installation and safety information. Assembled in USA Patents Pending www.kollmorgen.com			

5.3 Part Number Scheme

Use the part number scheme for product identification only, not for the order process, because not all combinations of features are possible, always.

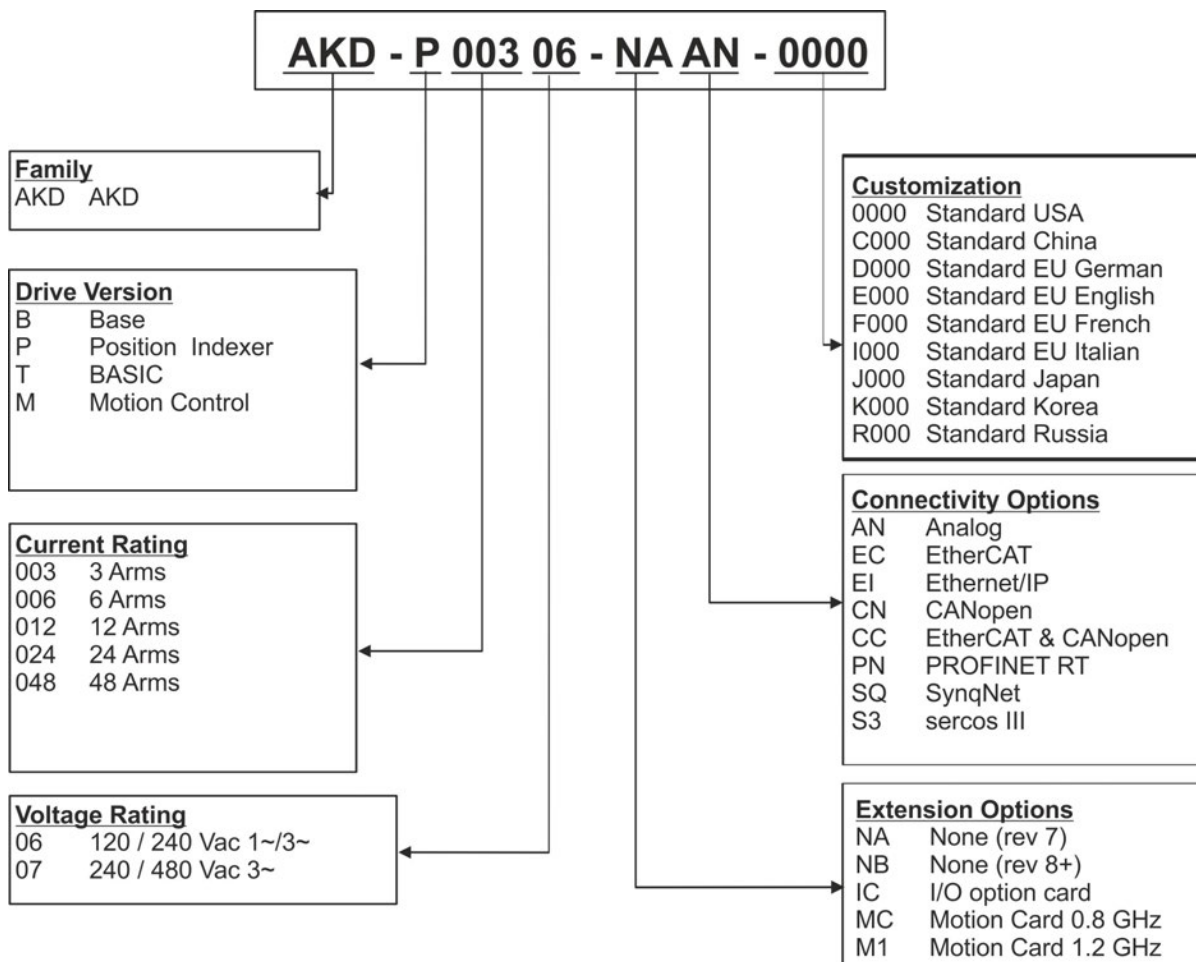

Customization: this code includes language version of printed material and customer specials.

Connectivity Options: The drive models with connectivity option CC are fitted with both the EtherCAT (X5 and X6) and CANopen (X12 and X13) fieldbus connectors. A software parameter (DRV.TYPE) allows you to select what features the drive supports; you cannot use EtherCAT and CANopen at the same time.

6 Technical description and data

6.1	The AKD Family of Digital Drives	31
6.2	Ambient Conditions, Ventilation, and Mounting Position	33
6.3	Mechanical Data	33
6.4	Inputs/Outputs	34
6.5	Electrical Data AKD-xzzz06	35
6.6	Electrical Data AKD-xzzz07	36
6.7	Performance Data	37
6.8	Recommended Tightening Torques	37
6.9	Grounding System	37
6.10	Fusing	38
6.11	Connectors	39
6.12	Cable and Wire Requirements	40
6.13	Dynamic Braking	41
6.14	Switch-On and Switch-Off Behavior	44
6.15	Stop / Emergency Stop / Emergency Off	51
6.16	Safe Torque Off (STO)	53
6.17	Shock-hazard Protection	64

6.1 The AKD Family of Digital Drives

Available AKD versions

Variant (short)	Description	Housing	Connectivity
AKD-B***	Base drive is controlled by analog torque & velocity commands (electronic gearing).	Standard	Analog, SynqNet
AKD-P**	Position Indexer drive adds the ability to command multiple motions, process I/O, make decisions, add time delays, modify drive process variables to the base drive.	Standard	Analog, CANopen, EtherCAT, PROFINET RT, Ethernet/IP, sercos® III
AKD-M***	Motion Controller PDMM/EtherCAT master drive. Includes all five IEC 61131 languages, PLC Open and Pipes Network. This drive is called AKD PDMM.	Extended width	EtherCAT
AKD-T***	Simple BASIC programmability added to the Base drive. This drive is called AKD BASIC.	Standard	Analog
AKD-T***-IC	AKD BASIC with I/O expansion.	Extended width	Analog, I/O expansion

Standard features

- Supply voltage range 120 V to 480 V $\pm 10\%$ (AKD-x04807 with 240 V to 480 V only)
- Several housing dimensions, depending on current and hardware options.
- Motion bus onboard, TCP/IP service channel onboard.
- SFD, Hiperface DSL, Tamagawa Smart Abs, Resolver, Comcoder, 1Vp-p Sin-Cos encoders, incremental encoders support onboard.
- Support for ENDAT 2.1 & 2.2, BiSS or HIPERFACE protocols onboard.
- Encoder emulation onboard and support for second feedback
- Safe Torque Off (STO) according to IEC 62061 SIL 2 onboard.
- Use with Synchronous servomotors, linear motors, and induction machines can be used.

Power section

- One or three phase supply, voltage range 120 to 480 V $\pm 10\%$, 50 to 400 Hz $\pm 5\%$ or DC. Connection to higher voltage mains only via isolating transformer, (\rightarrow # 102). Single phase supply possible with output power derating.
- B6 bridge rectifier, integral soft-start circuit.
- Fusing to be provided by the user.
- DC bus link voltage range 170 to 680 VDC, can be connected in parallel.
- Output stage IGBT module with floating current measurement.
- Regen circuit with dynamic distribution of the generated power between several drives on the same DC bus link circuit.
- Internal regen resistor for all AKD models (except AKD-x00306, AKD-x00606 and AKD-x04807), external regen resistors if required.

Integrated safety

- Appropriate insulation/creepage distances and electrical isolation for safe electrical separation, per IEC 61800-5-1, between the power input/motor connections and the signal electronics.
- Soft-start, overvoltage detection, short-circuit protection, phase-failure monitoring.
- Temperature monitoring of the drive and motor.
- Motor overload protection: foldback mechanism
- SIL 2 safe torque off in accordance with IEC 62061 , (→ # 53).

Auxiliary supply voltage 24V DC

- From an external, safety approved 24 V \pm 10% power supply.

Operation and parameter setting

- Using the setup software WorkBench for setup via TCP/IP or KAS IDE for AKD PDMM setup.

Full digital control

- Digital current controller (670 ns)
- Adjustable digital velocity controller (62.5 μ s)
- Software option position controller (250 μ s)

Inputs/Outputs

- 1 programmable analog input (→ # 148)
- 1 programmable analog output (→ # 149)
- 7 programmable digital inputs (→ # 150)
- 2 programmable digital outputs (→ # 157)
- 1 Enable input (→ # 150)
- 1 STO input (→ # 53)
- additional digital inputs and outputs depending on variants (for example AKD PDMM)

Option Cards

Integrated option cards affect the device width.

- IC: additional digital inputs and outputs.
- MC/M1: Motion Controller card with additional digital inputs and outputs. Extends the AKD to AKD PDMM type (part number scheme: AKD-M), a master drive for multiaxis, synchronized drive systems.

Connectivity

- Inputs/Outputs (→ # 144)
- Encoder feedback output (→ # 142)
- Service Interface (→ # 168)
- CANopen (→ # 172), optional
- Motion Bus interface (→ # 177)
 - SynqNet (→ # 179), optional
 - EtherCAT (→ # 178), optional
 - PROFINET RT (→ # 179), optional
 - Ethernet/IP (→ # 179), optional
 - sercos[®] III (→ # 180), optional

6.2 Ambient Conditions, Ventilation, and Mounting Position

Storage	(→ # 19)
Transport	(→ # 19)
Ambient temperature in operation	0 to +40 °C under rated conditions +40 to +55 °C with continuous current derating 4 % per Kelvin
Humidity in operation	Relative humidity 5 to 85%, no condensation, class 3K3
Site altitude	Up to 1000 meters above mean sea level without restriction 1,000 to max. 2,500 meters above mean sea level with power derating 1.5%/100 m
Pollution level	Pollution level 2 as per IEC 60664-1
Vibrations	Class 3M1 according to IEC 60721-3-3
Enclosure protection	IP 20 according to IEC 60529
Mounting position	Vertical, (→ # 67)
Ventilation	Built-in fan (except AKD-x00306 type)
NOTICE	The drive shuts down (fault F234, (→ # 199), motor has no torque) in case of excessively high temperature in the control cabinet. Make sure sufficient forced ventilation is supplied within the control cabinet.

6.3 Mechanical Data

Mechanical data	Units	AKD-x00306	AKD-x00606	AKD-x01206	AKD-x02406
Weight (standard width)	kg	1.1		2	3.7
Weight (extended width)	kg	1.3		2.2	4
Height, without connectors	mm	168		196	248
Height, with connector	mm	200		225	280
Standard Width front/back	mm	54/59		72/78.4	96/100
Extended Width front/back	mm	84/89		91/96	96/100
Depth, without connectors	mm	156		187	228
Depth, with connectors	mm	185		< 215	<265

Mechanical data	Units	AKD-x00307	AKD-x00607	AKD-x01207	AKD-x02407	AKD-x04807
Weight (standard width)	kg		2.7		5.3	11.5
Weight (extended width)	kg		2.9		5.5	11.7
Height, without connectors	mm		256		306	385
Height, with connector	mm		290		340	526
Standard Width front/back	mm		65/70		99/105	185/185
Extended Width front/back	mm		95/100		99/105	-
Depth, without connectors	mm		185		228	225
Depth, with connectors	mm		<225		<265	<265

6.4 Inputs/Outputs

Interface	Electrical Data
Analog inputs	<ul style="list-style-type: none"> ■ ± 12 VDC ■ Common Mode Rejection Ratio: > 30 dB at 60 Hz ■ resolution 16 bit and full monotonic ■ update rate: 16 kHz ■ nonlinearity < 0.1% of full scale ■ offset drift max. $250\mu\text{V}/^\circ\text{C}$ ■ input impedance > 13 kOhms
Analog outputs	<ul style="list-style-type: none"> ■ ± 10 VDC ■ max 20mA ■ resolution 16 bit and full monotonic ■ update rate: 4 kHz ■ nonlinearity < 0.1% of full scale ■ offset drift max. $250\mu\text{V}/^\circ\text{C}$ ■ short circuit protected to AGND ■ output impedance 110 Ohms
Digital inputs	<ul style="list-style-type: none"> ■ ON: 3.5 VDC to 30 VDC, 2 mA to 15 mA ■ OFF: -2 VDC to 2 VDC, max. 15 mA ■ galvanic isolation for 250 VDC
Digital outputs	<ul style="list-style-type: none"> ■ max. 30 VDC, 100 mA ■ short circuit proof ■ galvanic isolation for 250 VDC
Relay outputs	<ul style="list-style-type: none"> ■ max. 30 VDC, 1A ■ max. 42 VAC, 1 A ■ time open/close 10ms ■ isolation 400 VDC contact/coil

6.5 Electrical Data AKD-xzzz06

Electrical Data	Units	AKD-x00306	AKD-x00606	AKD-x01206	AKD-x02406
Rated supply voltage (L1/L2/L3)	V	3 x 120 V to 240 V $\pm 10\%$ 1 x 120 V to 240 V $\pm 10\%$			3x240 V $\pm 10\%$
Rated supply input frequency	Hz	50 Hz to 400 Hz $\pm 5\%$ or DC			
Rated input power for S1 operation	kVA	1.2	2.38	3.82	7.6
Rated input current					
at 1x120 V	A	5.0	9.9	12	-
at 1x240 V	A	5.0	9.9	12	-
at 3x120 V	A	2.3	4.6	9.2	-
at 3x240 V	A	2.3	4.6	9.2	18.3
Permitted switch on/off frequency, mains	1/h	30			
Max. inrush current	A	10	10	10	20
Rated DC bus link voltage (Bus Turn on Delay 3ph 1 sec)	V	170 to 340			
Continuous output current ($\pm 3\%$), single-phase or three-phase					
at 120 V	Arms	3	6	12	-
at 240 V	Arms	3	6	12	24
Peak output current (for 5 s, $\pm 3\%$)	Arms	9	18	30	48
Continuous output power @ rated input current					
at 1x120 V	VA	312.5	625	1250	-
at 1x240 V	VA	625	1250	2500	-
at 3x120 V	VA	312.5	625	1250	-
at 3x240 V	VA	625	1250	2500	5000
Peak output power (for 1 s)					
at 1x120 V	kVA	0.937	1.875	3.125	-
at 1x240 V	kVA	1.875	3.750	6.250	-
at 3x120 V	kVA	0.937	1.875	3.125	-
at 3x240 V	kVA	1.875	3.750	6.250	10
Technical data for regen circuit	—	(→ #41)			
Motor inductance min.					
at 120 V	mH	1.3	0.6	0.5	0.3
at 240 V	mH	2.5	1.3	1	0.6
Motor inductance max.	mH	250	125	100	60
Thermal dissipation, output stage disable	W	max. 20	max. 20	max. 20	max. 25
Thermal dissipation at rated current	W	31	57	137	175
Noise emission (low speed/high speed fan)	dB (A)	N/A	33/39	37/43	41/56
Aux. voltage supply (PELV)	V	24 V ($\pm 10\%$, check voltage drop)			
-current B, P, T types without/with motor brake	A	0.5 / 1.7	0.6 / 1.8	0.7 / 1.9	1.0 / 2.5
-current M type without/with motor brake	A	0.8 / 2.0	0.9 / 2.1	1.0 / 2.2	1.3 / 2.8

6.6 Electrical Data AKD-xzzz07

Electrical data	Units	AKD-x00307	AKD-x00607	AKD-x01207	AKD-x02407	AKD-x04807
Rated supply voltage (L1/L2/L3)	V	3 x 240 V to 480 V $\pm 10\%$				
Rated supply input frequency	Hz	AC with 50 Hz to 400 Hz $\pm 5\%$ or DC				
Rated input power for S1 operation	kVA	2.24	4.49	7.65	15.2	40.9
Rated input current						
at 3x240 V	A	2.7	5.4	9.2	18.3	49.3
at 3x400 V	A	2.7	5.4	9.2	18.3	49.3
at 3x480 V	A	2.7	5.4	9.2	18.3	49.3
Permitted switch on/off frequency, mains	1/h	30				
Max. inrush current	A	10	10	10	20	4
Rated DC bus link voltage (Bus Turn on Delay 3ph 1 sec)	V=	340 to 680				
Continuous output current ($\pm 3\%$)						
at 240 V	Arms	3	6	12	24	48
at 400 V	Arms	3	6	12	24	48
at 480 V	Arms	3	6	12	24	48
Peak output current (for 5 s, $\pm 3\%$)	Arms	9	18	30	48	96
Continuous output power @ rated input current						
at 3x240 V	kVA	0.6	1.25	2.5	5	10
at 3x400 V	kVA	1	2	4.2	8.3	16.6
at 3x480 V	kVA	1.2	2.5	5	10	20
Peak output power (for 1 s)						
at 3x240 V	kVA	1.8	3.75	6.25	10	20
at 3x400 V	kVA	3	6.75	10.4	16.7	33
at 3x480 V	kVA	3.6	7.5	12.5	20	40
Technical data for regen circuit	—	(→ #41)				
Motor inductance min.						
at 240 V	mH	3.2	1.6	1.3	0.6	0.3
at 400 V	mH	5.3	2.6	2.1	1	0.5
at 480 V	mH	6.3	3.2	2.5	1.2	0.6
Motor inductance max.	mH	600	300	250	120	60
Thermal dissipation, output stage disable	W	max. 20	max. 20	max. 20	max. 25	max. 25
Thermal dissipation at rated current	W	102	129	153	237	640
Noise emission (low speed/high speed fan)	dB(A)	34/43	34/43	44/52	48/58	48/72
Aux. voltage supply (PELV)	V=	24 V ($\pm 10\%$, check voltage drop)				
-current B, P, T types without/with motor brake	A=	1 / 2.5	1 / 2.5	1 / 2.5	2 / 4	2 / *
-current M type without/with motor brake	A=	1.3 / 2.8	1.3 / 2.8	1.3 / 2.8	2.3 / 4.3	2.3 / *

* = motor holding brake is supplied with separated 24 V $\pm 10\%$ auxiliary voltage (→ # 116).

6.7 Performance Data

AKD-xzzz06

Performance Data	Units	up to AKD-x00606	AKD-x01206	AKD-x02406
Switching frequency of output stage	kHz	10	8	8
Voltage rise speed dU/dt	kV/μs	2.5		4.3
Bandwidth of current controller	kHz	2.5 to 4	2 to 3	
Bandwidth of velocity controller (scalable)	Hz	0 to 1000	0 to 800	0 to 600
Bandwidth of position controller (scalable)	Hz	1 to 250		

AKD-xzzz07

Performance Data	Units	AKD-x00307	AKD-x00607	AKD-x01207	AKD-x02407	AKD-x04807
Switching frequency of output stage	kHz	8	8	6	8	8
Voltage rise speed dU/dt	kV/μs	7.2				
Bandwidth of current controller	kHz	2.5 to 4		2 to 3		2 to 3
Bandwidth of velocity controller (scalable)	Hz	0 to 800	0 to 600			0 to 600
Bandwidth of position controller (scalable)	Hz	1 to 250				

6.8 Recommended Tightening Torques

Connector	Tightening Torque/Nm (see (→ # 23) for in-lbs values.)			
	up to AKD-x00606	AKD-x01206	AKD-x02406, AKD-x00307 to AKD-x02407	AKD-x04807
X1	0.2 to 0.25	0.2 to 0.25	0.2 to 0.25	0.2 to 0.25
X2	0.5 to 0.6	0.7 to 0.8	0.7 to 0.8	0.7 to 0.8
X3	0.5 to 0.6	0.5 to 0.6	0.7 to 0.8	0.7 to 0.8
X4	-	-	0.7 to 0.8	0.7 to 0.8
X7, X8, X21, X22, X23, X24, X35, X36	0.2 to 0.25	0.2 to 0.25	0.2 to 0.25	0.2 to 0.25
X14	-	-	1.7 to 1.8	1.7 to 1.8
X15, X16	-	-	0.2 to 0.25	0.2 to 0.25
PE block	1.7	1.7	1.7	1.7

6.9 Grounding System

AGND	analog ground
DCOM7/8	common line for digital inputs on I/O connector X7, X8
DCOM21.x/22.x	common line for digital inputs on I/O connector X21, X22 (AKD-T-IC only)
DCOM35/36	common line for digital inputs on I/O connector X35, X36 (AKD-M only)
GND	24 V supply, STO input (up to AKD-x024), holding brake
STO-GND	STO-Enable inputs (AKD-x048)
0 V	internal digital ground, encoder emulation output, service channel

6.10 Fusing

EU Cartridge Fuses	US Cartridge Fuses
Types gS (gRL) or gG (gL), 400 V/500 V, time-delay	Class J, 600 V AC 200 kA, time-delay. The fuse must be UL and CSA listed.

Cartridge fuse holders: Combined with the standard fuse blocks, finger safe fuse holders must be used according to IEC 60529.

Examples Bussmann: CH Series Modular Fuse Holders, class J, 3 poles: CH30J3, CH14J3

Example Ferraz: Ultrasafe Fuse holders, class J, 3 poles: US3J3I

6.10.1 External power supply fusing

Drive Model	Max. Ampere rating	Example class J Bussmann	Example class J Ferraz Shawmut
AKD-x00306	10A (Time-Delay)	LPJ10SP/DFJ10	AJT10/HSJ10
AKD-x00606	15A (Time-Delay)	LPJ15SP/DFJ15	AJT15/HSJ15
AKD-x01206	15A (Time-Delay)	LPJ15SP/DFJ15	AJT15/HSJ15
AKD-x02406	30A (Time-Delay)	LPJ30SP/DFJ30	AJT30/HSJ30
AKD-x00307	6A (Time-Delay)	LPJ6SP/DFJ6	AJT6/HSJ6
AKD-x00607	10A (Time-Delay)	LPJ10SP/DFJ10	AJT10/HSJ10
AKD-x01207	15A (Time-Delay)	LPJ15SP/DFJ15	AJT15/HSJ15
AKD-x02407	30A (Time-Delay)	LPJ30SP/DFJ30	AJT30/HSJ30
AKD-x04807	60A (Time-Delay)	LPJ60SP/DFJ60	AJT60/HSJ60

6.10.2 External 24 V supply fusing

Drive Model	Max. Ampere rating	Example class J Bussmann	Example class J Ferraz Shawmut
all AKD	8A (Time-Delay)	LPJ8SP/DFJ8	AJT8

6.10.3 External regen resistor fusing

Drive Model	Ampere rating@240V	Ampere rating@480V	UL region example:	CE Region example:
AKD-x003 to 012	10A	40A	Bussmann FWP-xxA14F	Siba 110V to 400V: gRL xxA (gS)
AKD-x024	15A	50A		Siba 400V to 480V: aR xxA
AKD-x048	-	Fritzlen DC Powerswitch FPS (→ # 109)		

6.10.4 External DC Bus link fusing

Drive Model	Ampere rating	UL region example:	CE Region example:
AKD-x003 to 024	50A	Bussmann FWP-50A14F	Siba 110V to 400V: gRL 50A (gS) 400V to 480V: aR 50A
AKD-x048	125A	Bussmann FWP-125A14F	Siba 400V to 480V: aR 125A

6.11 Connectors

AKD-xzzz06 and AKD-xzzz07 types

Connector	Type	Max. Cross Section ¹	Current ²	Voltage ³
Control signals X7/X8	Terminal Connector, 10 poles	1.5 mm ² , 16 awg	10 A	250 V
Control signals X21/X22*	Terminal Connector, 8 poles	1.5 mm ² , 16 awg	10 A	250 V
Control signals X23/X24*	Terminal Connector, 14 poles	1.5 mm ² , 16 awg	10 A	250 V
Control signals X35/X36**	Terminal Connector, 8 poles	1.5 mm ² , 16 awg	10 A	250 V
Feedback X10	SubD 15pin HD (female)	0,5 mm ² , 21 awg	1 A	<100 V
Service Port X11, X32**	RJ45	0,5 mm ² , 21 awg	1 A	<100 V
Motion Bus X5, X6	RJ45	0,5 mm ² , 21 awg	1 A	<100 V
CAN In/Out X12/13	RJ25	0,5 mm ² , 21 awg	1 A	<100 V
Encoder Emulation X9	SubD 9pin (male)	0,5 mm ² , 21 awg	1 A	<100 V

* with I/O option card "IC" only

** with AKD-M variant only

AKD-xzzz06 types (120V to 240V Mains Voltage Supply)

Connector	Type	Max. Cross Section ¹	Current ²	Voltage ³
24V/STO X1 (03 to 24A)	Terminal Connector, 3 poles	1.5 mm ² , 16 awg	8 A	160 V
Motor X2 (3 to 6 A)	Terminal Connector, 6 poles	2.5 mm ² , 14 awg	10 A	320 V
Motor X2 (12 to 24 A)	Terminal Connector, 6 poles	10 mm ² , 8 awg	30 A	1000 V
Power/Regen X3 (3 to 6A)	Terminal Connector, 7 poles	2.5 mm ² , 14 awg	10 A	320 V
Power/Regen X3 (12 A)	Terminal Connector, 8 poles	2,5 mm ² , 14 awg	16 A	320 V
Regen X3 (24 A)	Terminal Connector, 4 poles	10 mm ² , 8 awg	30 A	1000 V
Power X4 (24 A)	Terminal Connector, 4 poles	10 mm ² , 8 awg	30 A	1000 V

AKD-xzzz07 types (240V to 480V Mains Voltage Supply)

Connector	Type	Max. Cross Section ¹	Current ²	Voltage ³
24V/STO X1 (03 to 24A)	Terminal Connector, 3 poles	1.5 mm ² , 16 awg	8 A	160 V
24V/STO X1 (48A)	Terminal Connector, 8 poles	1.5 mm ² , 16 awg	8 A	160 V
Motor X2 (03 to 24A)	Terminal Connector, 6 poles	10 mm ² , 8 awg	30 A	1000 V
Motor X2 (48A)	Terminal Connector, 4poles	16 mm ² , 6 awg	54 A	1000 V
Regen X3 (03 to 24A)	Terminal Connector, 4 poles	10 mm ² , 8 awg	30 A	1000 V
Regen X3 (48A)	Terminal Connector, 3 poles	16 mm ² , 6 awg	54 A	1000 V
Power X4 (03 to 24A)	Terminal Connector, 4 poles	10 mm ² , 8 awg	30 A	1000 V
Power X4 (48A)	Terminal Connector, 4 poles	16 mm ² , 6 awg	54 A	1000 V
DC-Bus X14 (48A)	Terminal Connector, 3 poles	16 mm ² , 6 awg	54 A	1000 V
24V Brake X15 (48A)	Terminal Connector, 2 poles	1.5 mm ² , 16 awg	8 A	160 V
Brake X16 (48A)	Terminal Connector, 2 poles	1.5 mm ² , 16 awg	8 A	160 V

¹single-line connection

²single-line connection with recommended conductor cross section (→ # 40)

³rated voltage with pollution level 2 (lowest values according to UL840 and IEC60664)

6.12 Cable and Wire Requirements

6.12.1 General

For information on the chemical, mechanical, and electrical characteristics of the cables please refer to the accessories manual or contact customer support.

NOTE

To reach the maximum permitted cable length, you must use cable material with the following capacitance (phase to shield) requirements:

- Motor cable: less than 150 pF/m
- Resolver/Encoder cable: less than 120 pF/m

Motor cables longer than 25 m may require the use of a motor choke.

6.12.2 Cable cross sections and requirements

The table below describes the recommended interface cross sections and cable requirements for single-axis systems in accordance with IEC 60204. For multi-axis systems, observe the specific operating conditions for your system.

Interface	Cross Section	Cable Requirements
AC connection	up to AKD-x006: 1.5 mm ² (16 awg) AKD-x012: 2.5 mm ² (14 awg) AKD-x024: 4 mm ² (12 awg) AKD-x048: 16 mm ² (6 awg)	600 V, minimum 75°C
DC bus link, regen resistor	AKD-x006: 1.5 mm ² (16 awg) AKD-x012 to 24: 2.5 mm ² (14 awg) AKD-x048: 4 mm ² (12 awg)	1000 V, minimum 75°C, shielded for lengths >0.20 m
Motor cables without choke, max. 25 m	up to AKD-x006: 1.5 mm ² (16 awg) AKD-x012: 2.5 mm ² (14 awg) AKD-x024: 4 mm ² (12 awg) AKD-x048: 16 mm ² (6 awg)	600 V, minimum 75°C, shielded, capacitance <150 pF/m
Motor cables with choke, 25 - 50 m	up to AKD-x006: 1.5 mm ² (16 awg) AKD-x012: 2.5 mm ² (14 awg) AKD-x024: 4 mm ² (12 awg)	600 V, minimum 75°C, shielded, capacitance <150 pF/m
Resolver, max. 100 m	4x2x0.25 mm ² (24 awg)	twisted pairs, shielded, capacitance <120 pF/m
SFD, max. 50 m	1x2x0.25 mm ² (24 awg) 1x2x0.50 mm ² (21 awg)	twisted pairs, shielded
SFD3/DSL, max. 25 m	1x2x0.50 mm ² (21 awg)	twisted pairs, shielded
Encoder, max. 50 m	7x2x0.25 mm ² (24 awg)	twisted pairs, shielded
ComCoder, max. 25 m	8x2x0.25 mm ² (24 awg)	twisted pairs, shielded
Analog I/Os, max. 30 m	0.25 mm ² (24 awg)	twisted pairs, shielded
Digital I/Os, max. 30 m	0.5 mm ² (21 awg)	single line
Holding brake (motor)	min. 0.75 mm ² (19 awg)	600 V, minimum 75°C, shielded
+24 V / GND, max 30 m	max. 2.5 mm ² (14 awg)	single line

6.13 Dynamic Braking

Dynamic braking is a method to slow down a servo system by dissipating the mechanical energy driven by the motor back EMF. The AKD has a built in advanced dynamic braking mode which operates fully in hardware. When activated, the drive shorts the motor terminals in phase with the back EMF (q axis) but continues to operate the non-force producing current loop (d-axis) with 0 current. This forces all of the dynamic braking current to be stopping current and insures the fastest stopping/amp of motor terminal current.

- When current is not being limited, the mechanical energy is being dissipated in the motor resistance.
- When current is being limited, energy is returned to the drive bus capacitors.
- The drive also limits the maximum dynamic braking motor terminal current via the *DRV.DBILIMIT* parameter to insure that the drive, motor, and customer load do not see excessive currents/forces.

Whether and how the AKD uses dynamic braking depends on (*DRV.DISMODE*).

6.13.1 Regen circuit

When the amount of returned energy builds the bus capacitor voltage up enough the drive activates the regen circuit to start dumping the returned energy in the regen resistor (also called regenerative or brake resistor). This resistor could be internal or connected external to the drive, depending on drive model and drive wiring.

AKD-x00306 to AKD-x00606, AKD-x04807

No internal regen resistor. Depending on the application requirements, an external resistor can be connected.

AKD-x01206 to AKD-x02406 and AKD-x00307 to AKD-x02407

With internal resistor plus the ability to connect an external resistor depending on the application requirements.

External regen resistors are described in the regional *AKD Accessories Manual*.

6.13.2 Functional description

When the amount of returned energy builds the bus capacitor voltage up enough the drive activates the brake chopper to start dumping the returned energy in the regen resistor.

1. Individual drives, not coupled through the DC bus link circuit (+DC, -DC)

When the energy fed back from the motor has an average or peak power that exceeds the pre-set level for the regen power rating, the drive generates the warning "n521 Regen Over power". If the power increases past the fault level, the regen circuit will switch off.

With the regen circuit switched off, the drive internal DC bus link voltage is supervised. The drive reports an over-voltage fault if the DC bus threshold is exceeded. The drive power stage is disabled and the load coasts to a stop with the fault message "F501 Bus Over voltage" (→ # 199). The Fault contact (terminals X8/9-10) is opened (→ # 158) due to this fault.

2. Several drives coupled through the DC bus link (+DC, -DC)

Using the built-in regen circuit, several drives of the same series can be operated from a common DC-bus link (→ # 106), without any additional measures. 90% of the combined power of all the coupled drives is always available for peak and continuous power. The switch-off on over voltage takes place as described under 1. (above) for the drive that has the lowest switch-off threshold (resulting from tolerances).

NOTE

Observe the regeneration time (some minutes) after full load with peak regen power.

6.13.3 Technical data for AKD-xzzz06

Technical data for the regen circuit depends on the drive type and the mains voltage.
Supply voltages, capacitances, and switch-on voltages are all nominal values.

Brake circuit			Supply voltage
Type	Rated data	Units	120 V / 240 V
AKD-xzzz06 all types	Switch-on threshold of regen circuit	V	380
	Overtoltage limit	V	420
	Maximum regen duty cycle	%	15*
Type	Rated data	Units	120 V / 240 V
AKD-x00106	External regen resistor	Ohm	33
	Maximum continuous regen power, external resistor	kW	0.48
	Peak regen power, external (1s)	kW	5.4
	Absorption energy in capacitors (+/- 20%)	Ws	60 / 20
	DC Bus Capacitance	µF	940
AKD-x00306	External regen resistor	Ohm	33
	Maximum continuous regen power, external resistor	kW	0.77
	Peak regen power, external (1s)	kW	5.4
	Absorption energy in capacitors (+/- 20%)	Ws	60 / 20
	DC Bus Capacitance	µF	940
AKD-x00606	External regen resistor	Ohm	33
	Maximum continuous regen power, external resistor	kW	1.5
	Peak regen power, external resistor (1s)	kW	5.4
	Absorption energy in capacitors (+/- 20%)	Ws	60 / 20
	DC Bus Capacitance	µF	940
AKD-x01206	Internal regen resistor	Ohm	15
	Continuous power, internal resistor	W	100
	Peak regen power, internal resistor (0.5s)	kW	11.7
	External regen resistor	Ohm	15
	Maximum continuous regen power, external resistor	kW	3
	Absorption regen power, external resistor (1s)	kW	5.4
	Storeable energy in capacitors (+/- 20%)	Ws	160 / 55
	DC Bus Capacitance	µF	2460
AKD-x02406	Internal regen resistor	Ohm	8
	Continuous power, internal resistor	W	200
	Peak regen power, internal resistor (0.5s)	kW	22
	External regen resistor	Ohm	15
	Maximum continuous regen power, external resistor	kW	6
	Peak regen power, external resistor (1s)	kW	11.8
	Absorption energy in capacitors (+/- 20%)	Ws	180 / 60
	DC Bus Capacitance	µF	2720

* depends on connected regen resistor power

6.13.4 Technical data for AKD-xzzz07

Technical data for the regen circuit depends on the drive type and the mains voltage. Supply voltages, capacitances, and switch-on voltages are all nominal values.

Brake circuit			Supply voltage	
Type	Rated data	Units	240 V	400 V / 480 V
AKD-xzzz07 all types	Switch-on threshold of regen circuit	V	380	760
	Overvoltage limit	V	420	840
	Maximum regen duty cycle	%	15*	
Type	Rated data	Units	240 V	400 V / 480 V
AKD-x00307	Internal regen resistor	Ohm	33	
	Continuous power, internal resistor	W	80	
	Peak regen power, internal resistor (0.5s)	kW	5.5	22.1
	External regen resistor	Ohm	33	
	Continuous regen power, external resistor	kW	0.77	1.5
	Peak regen power, external (1s)	kW	5.4	21.4
	Absorption energy in capacitors (+/- 20%)	Ws	5	35 / 20
	DC Bus Capacitance	µF	235	
AKD-x00607	Internal regen resistor	Ohm	33	
	Continuous power, internal resistor	W	100	
	Peak regen power, internal resistor (0.5s)	kW	5.4	21.4
	External regen resistor	Ohm	33	
	Continuous regen power, external resistor	kW	1.5	3
	Peak regen power, external resistor (1s)	kW	5.4	21.4
	Absorption energy in capacitors (+/- 20%)	Ws	5	35 / 20
	DC Bus Capacitance	µF	235	
AKD-x01207	Internal regen resistor	Ohm	33	
	Continuous power, internal resistor	W	100	
	Peak regen power, internal resistor (0.5s)	kW	5.4	21.4
	External regen resistor	Ohm	33	
	Continuous regen power, external resistor	kW	3	6
	Peak regen power, external resistor (1s)	kW	5.4	21.4
	Absorption energy in capacitors (+/- 20%)	Ws	10	70 / 40
	DC Bus Capacitance	µF	470	
AKD-x02407	Internal regen resistor	Ohm	23	
	Continuous power, internal resistor	W	200	
	Peak regen power, internal resistor (0.5s)	kW	7.7	30.6
	External regen resistor	Ohm	23	
	Continuous regen power, external resistor	kW	6	12
	Peak regen power, external resistor (1s)	kW	7.7	30.6
	Absorption energy in capacitors (+/- 20%)	Ws	15	110 / 60
	DC Bus Capacitance	µF	680	
AKD-x04807	External regen resistor	Ohm	10	
	Continuous regen power, external resistor	kW	6	12
	Peak regen power, external resistor (1s)	kW	17.6	70.5
	Absorption energy in capacitors (+/- 20%)	Ws	20	146 / 80
	DC Bus Capacitance	µF	900	

* depends on connected regen resistor power

6.14 Switch-On and Switch-Off Behavior

This chapter describes the switch-on and switch-off behavior of the AKD.

Behavior of “holding brake” function

Drives with an enabled holding brake function have a special timing for switching on and off the output stage (→ # 116). Events that remove the DRV.ACTIVE signal trigger the holding brake to apply. As with all electronic circuits, the general rule applies that there is a possibility of the internal holding brake module failing.

Functional safety, e.g. with hanging load (vertical axes), requires an additional mechanical brake which must be safely operated, for example by a safety control.

If velocity drops below threshold *CS.VTHRESH* or timeout occurs during a stop procedure, the brake is applied. Set parameter MOTOR.BRAKEIMM to 1 with vertical axes, to apply the motor holding brake (→ # 116) immediately after faults or Hardware Disable.

Behavior when undervoltage condition is present

The behavior in an undervoltage condition depends on the VBUS.UVMODE setting.

VBUS.UVMODE	DC Bus Undervoltage Mode. Consult the <i>WorkBench Online Help</i> for configuring the parameter.
0	The drive will report a F502 undervoltage fault any time an undervoltage condition occurs.
1 (default)	The drive will report a warning n502 if not enabled. The drive will report a fault if the drive is enabled when the condition occurs, or an attempt is made to enable while an under voltage condition occurs.

Safety function STO

With the functional safe function STO, the drive can be secured on standstill using its internal electronics so that even when power is being supplied, the drive shaft is protected against unintentional restart. The chapter “Safe Torque Off (STO)” describes how to use the STO function (→ # 53).

6.14.1 Switch-on behavior in standard operation

The diagram below illustrates the correct functional sequence for switching the drive on.

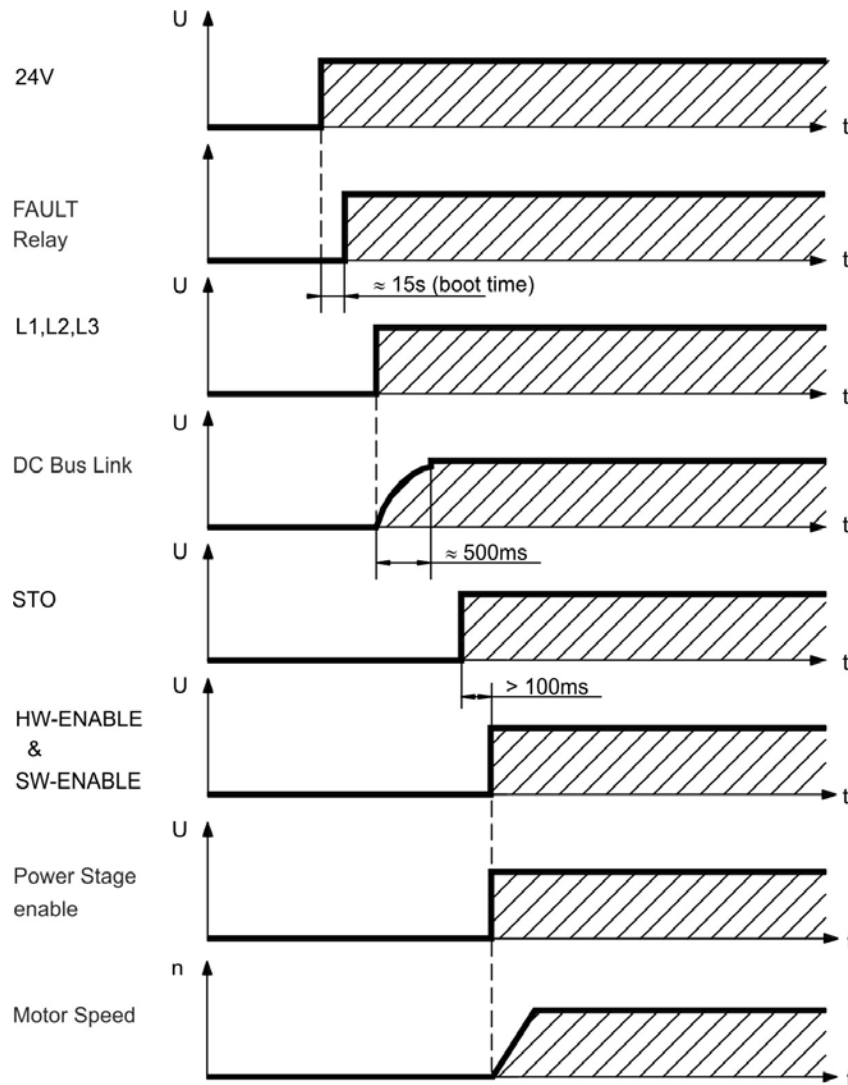

Fault F602 occurs when STO (\rightarrow # 53) does not have current when HW enable becomes active.

6.14.2 Switch-off behavior

NOTE

The drive's 24 V supply must remain constant. Hardware Enable input disables the power stage immediately. Configured Digital Inputs and fieldbus commands can be used to perform controlled stops.

6.14.2.1 Switch-off behavior using the DRV.DIS command

The enable/disable button in WorkBench issues a *drv.dis* command internally to the drive. See *WorkBench Online Help* for configuring inputs and software commands. Sometimes this enable signal is called "Software Enable" (SW-Enable).

DRV.DISMODE	DRV.DISMODE controls the behavior of the <i>drv.dis</i> command issued through WorkBench, or terminal, or fieldbus. Consult the <i>WorkBench Online Help</i> for configuring.
0	Disable axis immediately, if velocity drops below threshold <i>CS.VTHRESH</i> or timeout occurs brake is applied. Category 0 stop according to IEC 60204 (→ # 51).
2	Use controlled stop to disable drive, if velocity drops below threshold <i>CS.VTHRESH</i> or timeout occurs brake is applied. Category 1 stop according to IEC 60204 (→ # 51).

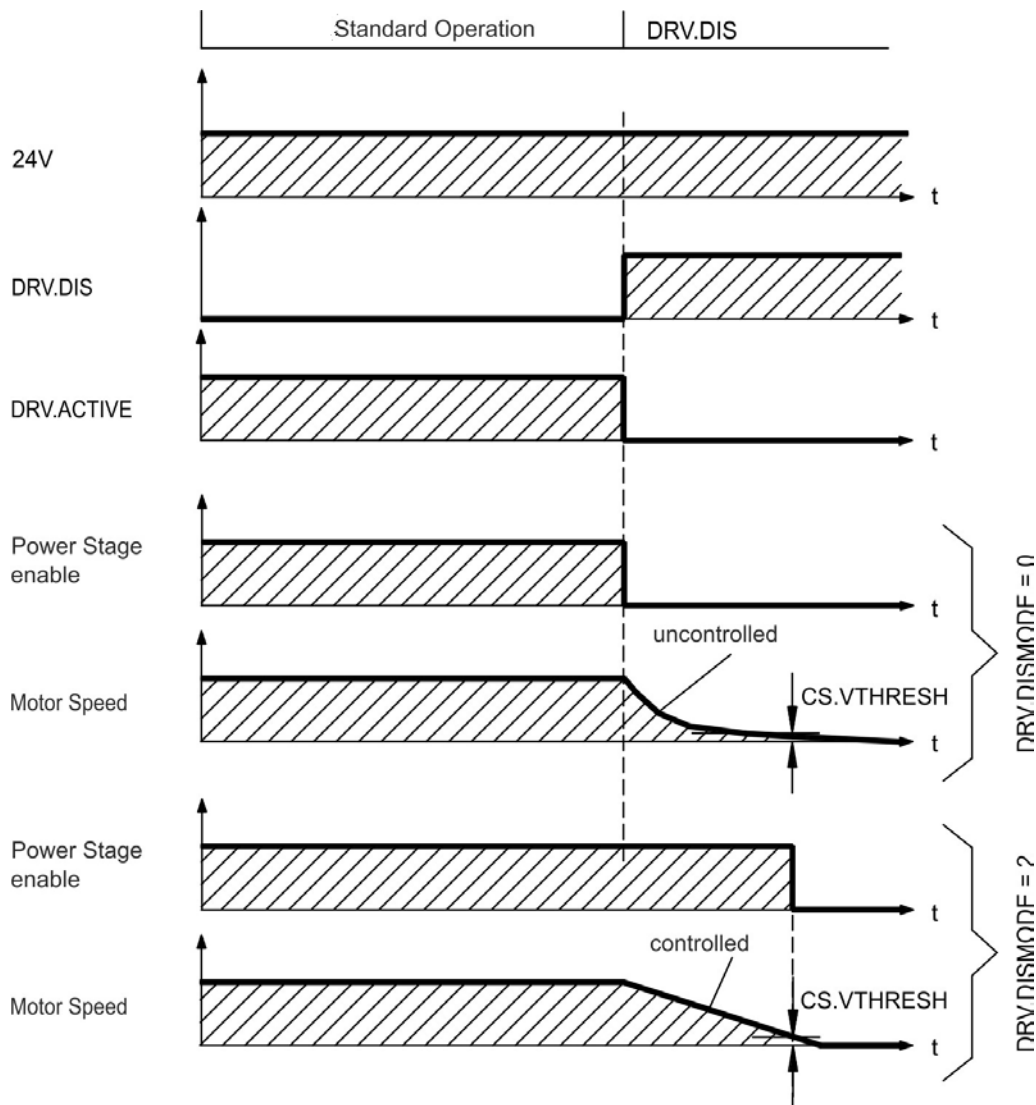

If velocity drops below threshold *CS.VTHRESH* or timeout occurs brake is applied (→ # 116).

6.14.2.2 Switch-off behavior using a digital input (controlled stop)

This is a category 2 stop according to IEC 60204 (→ # 51).

A digital input can be configured to bring the motor to a controlled stop and then disable the drive and apply the holding brake.(if present). See the *WorkBench Online Help* for information on configuring Digital Inputs.

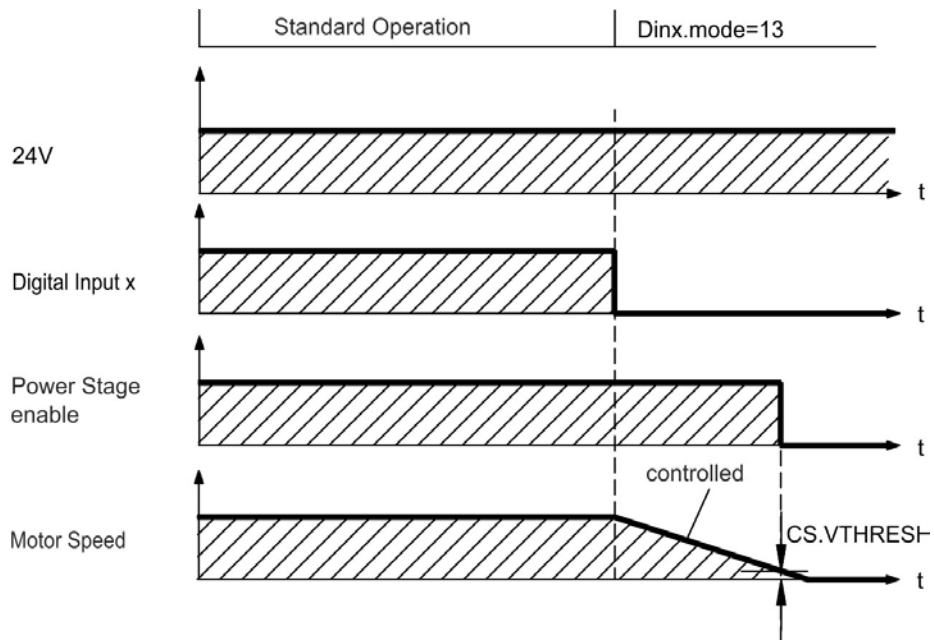

If velocity drops below threshold *CS.VTHRESH* or timeout occurs brake is applied (→ # 116).

6.14.2.3 Switch-off behavior using HW Enable input (uncontrolled stop)

This is a category 0 stop according to IEC 60204 (→ # 51).

The hardware enable input disables the power stage immediately.

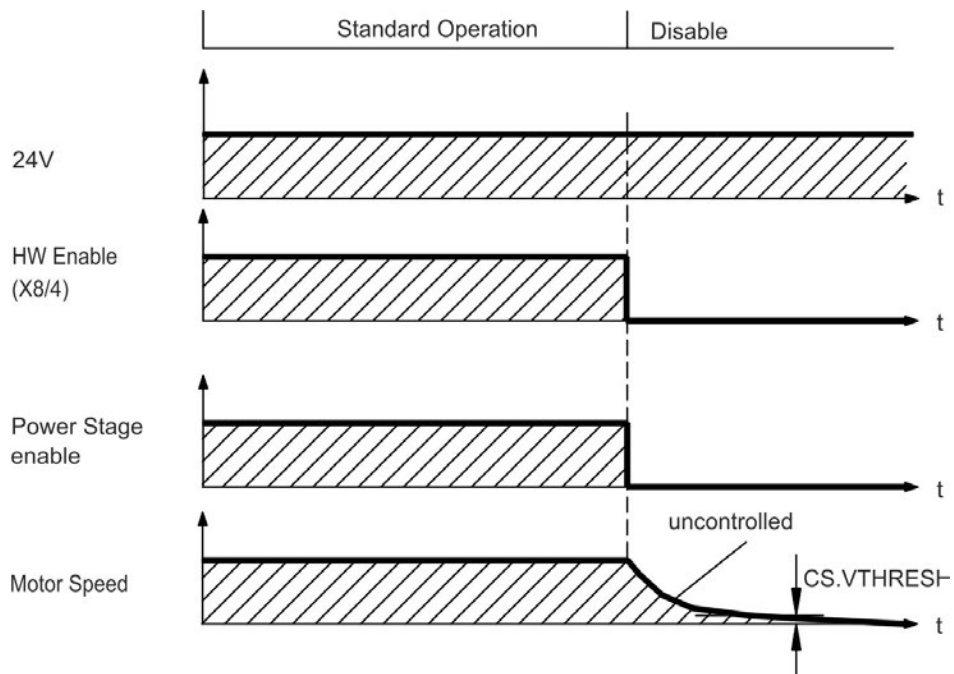

If velocity drops below threshold *CS.VTHRESH* or timeout occurs the motor holding brake is applied (→ # 116). Set parameter *MOTOR.BRAKEIMM* to 1 with vertical axes, to apply the motor holding brake immediately after Hardware Disable.

6.14.2.4 Switch-off behavior in the event of a fault

The behavior of the drive always depends on the fault type and the setting of a number of different parameters (DRV.DISMODE, VBUS.UVFTHRESH, CS.VTHRESH, and others; see the *WorkBench Online Help* for more details). See the *Drive Fault and Warning Messages and Remedies* section of the *WorkBench Online Help* for a table describing the specific behavior of each fault.

The following pages show examples for the possible fault behaviors.

Switch-off behavior for faults that cause an immediate power stage disable

This is a category 0 stop according to IEC 60204 (→ # 51).

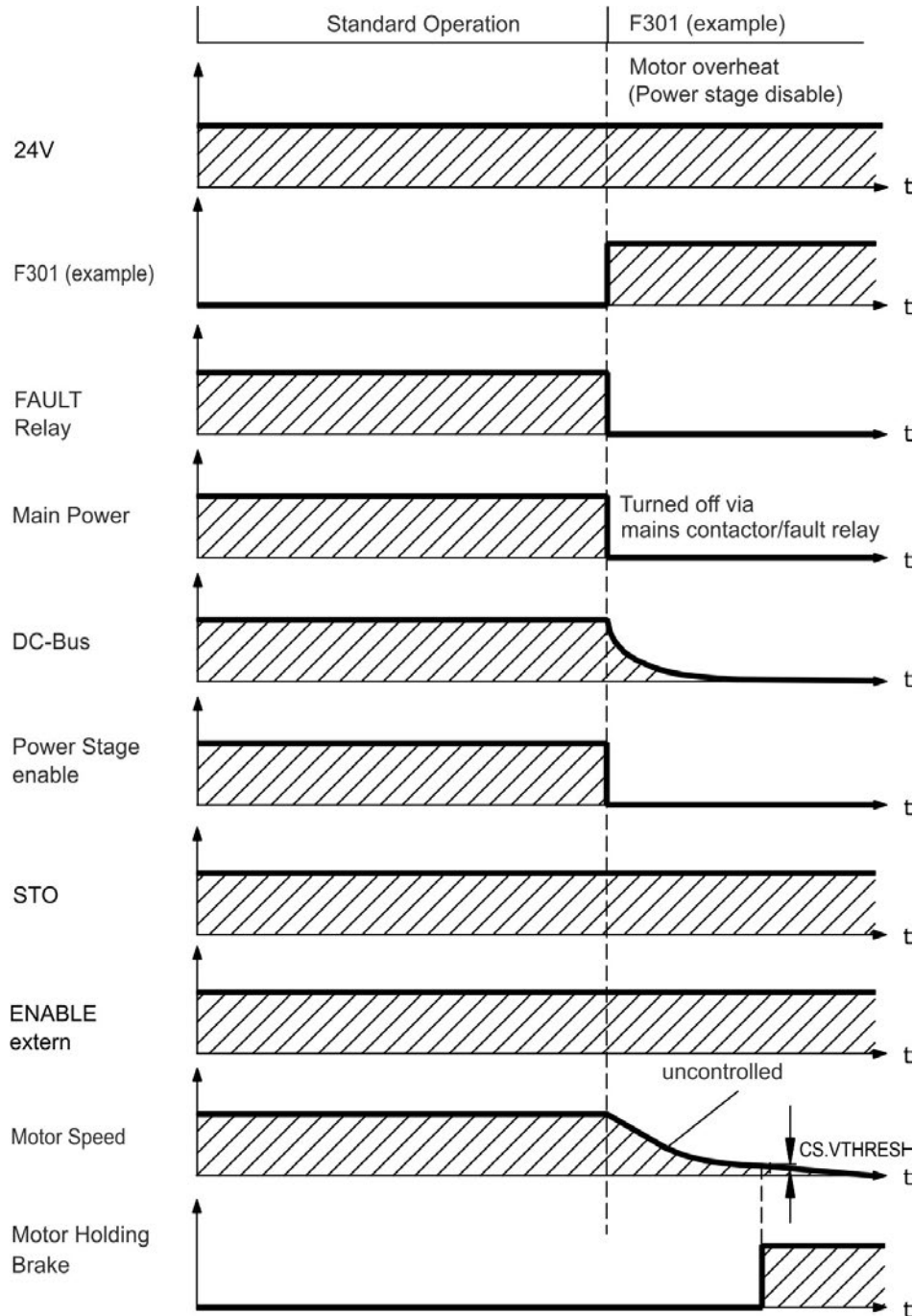

If velocity drops below threshold $CS.VTHRESH$ or timeout occurs the motor holding brake is applied (→ # 116). Set parameter MOTOR.BRAKEIMM to 1 with vertical axes, to apply the motor holding brake immediately after faults.

Switch-off behavior for faults that cause dynamic braking

This is a category 0 stop according to IEC 60204 (→ # 51).

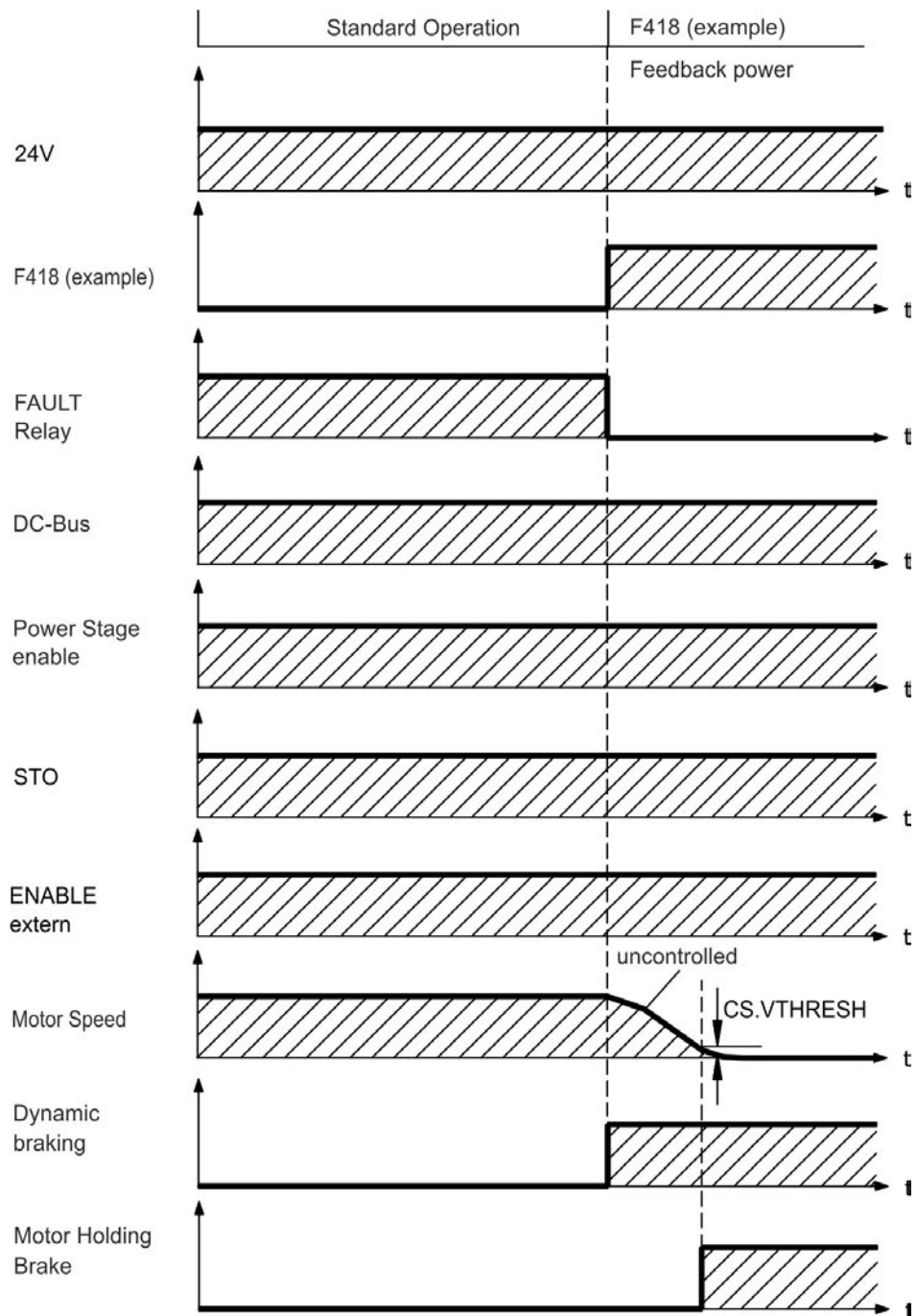

If velocity drops below threshold $CS.VTHRESH$ or timeout occurs brake is applied (→ # 116).

Switch-off behavior for faults that cause a controlled stop

This is a category 1 stop according to IEC 60204 (→ # 51).

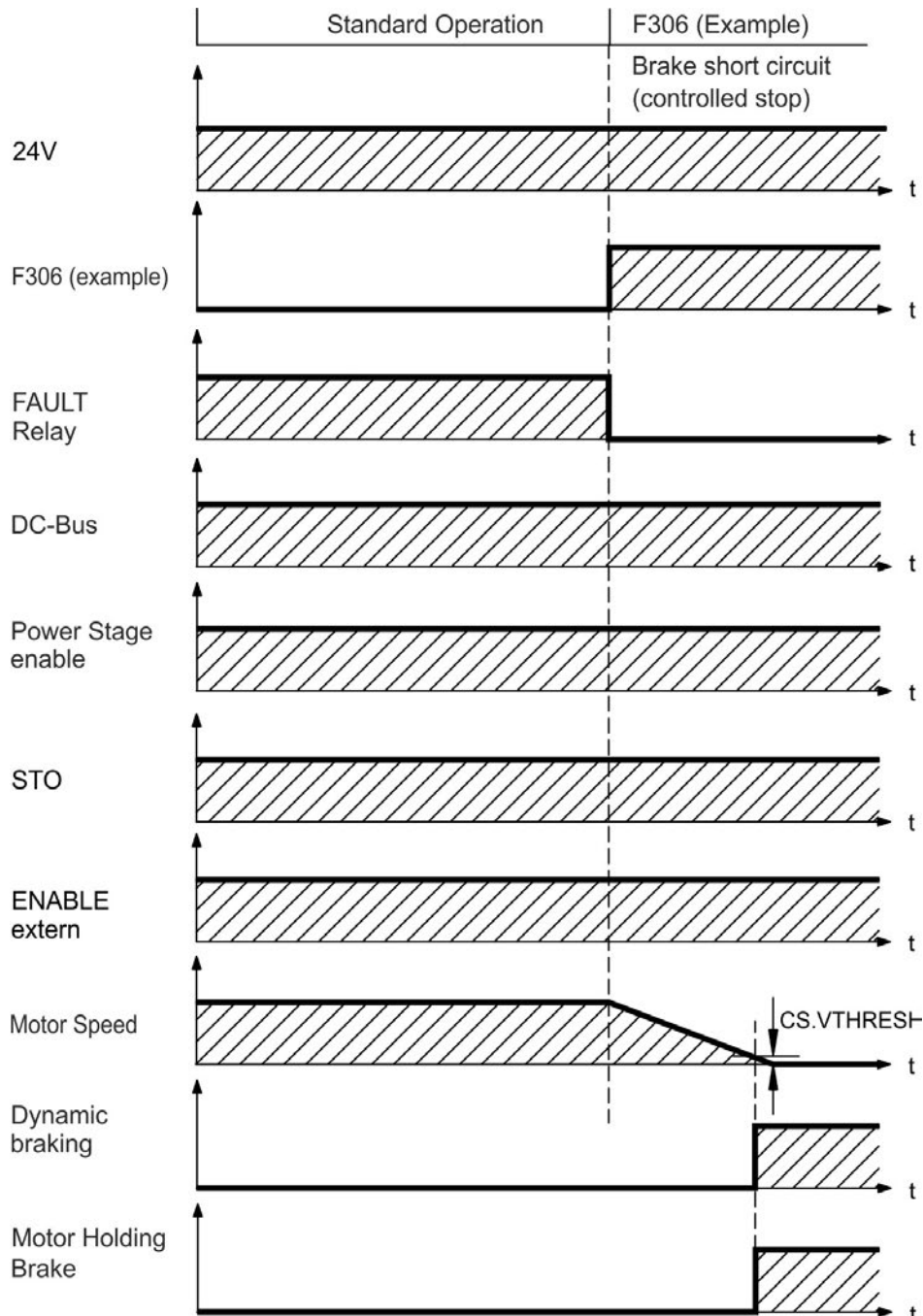

If velocity drops below threshold $CS.VTHRESH$ or timeout occurs brake is applied (→ # 116).

6.15 Stop / Emergency Stop / Emergency Off

The control functions Stop, Emergency Stop and Emergency Off are defined by IEC 60204. Notes for safety aspects of these functions can be found in ISO 13849 and IEC 62061.

NOTE

The parameter DRV.DISMODE must be set to 2 to implement the different stop categories. Consult the *WorkBench Online Help* for configuring the parameter.



WARNING

With vertical load the load could fall. Serious injury could result when the load is not properly blocked. Functional safety, e.g. with hanging load (vertical axes), requires an additional mechanical brake which must be safely operated, for example by a safety control.

Set parameter MOTOR.BRAKEIMM to 1 with vertical axes, to apply the motor holding brake ((→ # 116)) immediately after faults or Hardware Disable.

6.15.1 Stop

The stop function shuts down the machine in normal operation. The stop function is defined by IEC 60204.

NOTE

The Stop Category must be determined by a risk evaluation of the machine.

Stop function must have priority over assigned start functions. The following stop categories are defined:

Stop Category 0

Shut-down by immediate switching-off the energy supply to the drive machinery (this is an uncontrolled shut-down). With the approved safety function STO ((→ # 53)) the drive can be stopped using its internal electronics (IEC 61508 SIL2).

Stop Category 1

A controlled shut-down, whereby the energy supply to the drive machinery is maintained to perform the shut-down, and the energy supply is only interrupted when the shut-down has been completed.

Stop Category 2

A controlled shut-down, whereby the energy supply to the drive machinery is maintained.

Stop Category 0 and Stop Category 1 stops must be operable independently of the operating mode, whereby a Category 0 stop must have priority.

If necessary, provision must be made for the connection of protective devices and lock-outs. If applicable, the stop function must signal its status to the control logic. A reset of the stop function must not create a hazardous situation.

6.15.2 Emergency Stop

The Emergency Stop function is used for the fastest possible shutdown of the machine in a dangerous situation. The Emergency Stop function is defined by IEC 60204. Principles of emergency stop devices and functional aspects are defined in ISO 13850.

The Emergency Stop function will be triggered by the manual actions of a single person. It must be fully functional and available at all times. The user must understand instantly how to operate this mechanism (without consulting references or instructions).

NOTE

The Stop Category for the Emergency Stop must be determined by a risk evaluation of the machine.

In addition to the requirements for stop, the Emergency Stop must fulfil the following requirements:

- Emergency Stop must have priority over all other functions and controls in all operating modes.
- The energy supply to any drive machinery that could cause dangerous situations must be switched off as fast as possible, without causing any further hazards (Stop Category 0) or must be controlled in such a way, that any movement that causes danger, is stopped as fast as possible (Stop Category 1).
- The reset must not initiate a restart.

6.15.3 Emergency Off

The Emergency Off function is used to switch-off the electrical power supply of the machine. This is done to prevent users from any risk from electrical energy (for example electrical impact). Functional aspects for Emergency Off are defined in IEC 60364-5-53.

The Emergency Off function will be triggered by the manual actions of a single person.

NOTE

The result of a risk evaluation of the machine determines the necessity for an Emergency Off function.

Emergency Off is done by switching off the supply energy by electro-mechanical switching devices. This results in a category 0 stop. If this stop category is not possible in the application, then the Emergency Off function must be replaced by other measures (for example by protection against direct touching).

6.16 Safe Torque Off (STO)

The STO safety implementation on the AKD is certified. The safety circuit implementation used for the safety function "Safe Torque Off" in the drive is suited for SIL 2 according to IEC 62061 and PLd / CAT3 according to ISO 13849-1. With AKD-x04807 drives SIL3/PLe is possible, if both STO-Enable inputs and the corresponding STO-Status signals are used.

AKD-x003 up to AKD-x024

An additional digital input (STO) releases the power output stage of the drive as long as a 24 V signal is applied to this input. If the STO input goes open-circuit, then power will no longer be supplied to the motor, and the drive will lose all torque and coast to a stop.

NOTE

This input is not compatible with IEC 61131-2. You can thus achieve a category 0 stop (→ # 51) by using the STO input without switching a mains contactor.

AKD-x048

Two additional digital inputs (STO-Enable1 and STO-Enable2) release the power output stage of the drive as long as a 24 V signal is applied to these inputs. If one of the STO inputs goes open-circuit, then power will no longer be supplied to the motor, and the drive will lose all torque and coast to a stop.

NOTE

The inputs are not compatible with IEC 61131-2. You can thus achieve a category 0 stop (→ # 51) by using the STO inputs without switching a mains contactor.

6.16.1 Safety characteristic data

The subsystems (AKD) are described with the following characteristic data:

AKD-x003 up to AKD-x024

Function	Operation mode	ISO 13849-1	IEC 62061	PFH [1/h]	T _M [Years]	SFF [%]
STO	single channel	PL d, CAT 3	SIL 2	0	20	100

AKD-x048

Function	Operation mode	ISO 13849-1	IEC 62061	PFH [1/h]	T _M [Years]	SFF [%]
STO	single channel	PL d, CAT 2	SIL 2	1.88E-07	20	89
STO	dual channel	PL d, CAT 3	SIL 2	5.64E-09	20	87
STO	dual channel with periodical testing	PL e, CAT 4	SIL 3	5.64E-09	20	87

NOTICE

A very unlikely but possible event can happen, if within a very short time 2 not adjacent IGBTs will have a short circuit. In such case a movement of maximum an angle of 120° (electrical) can happen. This effect can only happen if the drive is in the function STO. If the total failure rate of the IGBT is 120 fit normally for such short circuit 60 fit will be valid (50:50 model). By such event 2 specific IGBTs have to fail at same time. The calculation shows a probability of $1.5 \cdot 10^{-15}$ per hour (without common cause failure). Even if the STO function will be issued for a whole year, this event will only happen every 100 Billion years.

6.16.2 Safety instructions



WARNING

The drive cannot hold a vertical load when STO function is active. Serious injury could result when load is not properly blocked. Drives with a suspended load must have an additional safe mechanical blocking (for instance, by a safe brake). Use with elevator applications is not allowed.



WARNING

The drive might restart automatically after power on, voltage dip or interruption of the supply voltage, depending on the parameter setting. Risk of death or serious injury for humans working in the machine. If the parameter DRV.ENDEFAULT is set to 1, then place a warning sign to the machine (Warning: Automatic Restart at Power On) and ensure, that power on is not possible, while humans are in a dangerous zone of the machine. In case of using an undervoltage protection device, you must observe EN 60204-1:2006 chapter 7.5 .



CAUTION

The STO function does not provide an electrical separation from the power output. There is a danger of electrical shock and personnel injury! If access to the motor power terminals is necessary, the drive must be disconnected from mains supply considering the discharging time of the intermediate circuit.



CAUTION

In case of a specific double fault within a very short time (see (→ # 53) a single movement of maximum an angle of 120° (electrical) can happen. This effect can only happen if the drive is in the function STO. Even if the STO function will be issued for a whole year, this event will only happen every 100 Billion years.

NOTICE

In case of single channel control: If the safety function STO is automatically activated by a control system, then make sure that the output of the control is monitored for possible malfunction. The monitoring can be used to prevent a faulty output from unintentionally activating the STO function. If the STO function is a single-channel system, erroneous engaging will not be recognized.

NOTICE

It is not possible to perform a controlled brake if the drive controlled STO-Enable is off. If controlled braking before the use of the STO function is necessary, the drive must be braked and the input STO must be separated time-delayed from +24 V .

NOTICE

Use the following functional sequence when the STO function is used:

1. Brake the drive in a controlled manner (speed setpoint = 0 V).
2. When speed = 0 rpm, disable the drive (enable = 0 V).
3. If a suspended load is present, block the drive mechanically.
4. Activate the STO function.

6.16.3 Use as directed

The STO function is exclusively intended to provide a functional safe stop of the motion system. To achieve this functional safety, the wiring of the safety circuits must meet the safety requirements of IEC 60204, ISO 12100 and ISO 13849.

6.16.4 Prohibited use

The STO function must not be used if the drive is to be made inactive for:

- Cleaning, maintenance and repair operations, long inoperative periods. In such cases, the entire system should be disconnected from the supply and secured (main switch).
- Emergency-Off situations. In an Emergency-Off situation, the main contactor is switched off (by the Emergency-Off button).

6.16.5 Technical data and pinout

AKD-x003 up to AKD-x024

Input STO (X1)

- Reference ground is GND
- 24 V $\pm 10\%$, 20 mA
- galvanic isolation for 250 VDC

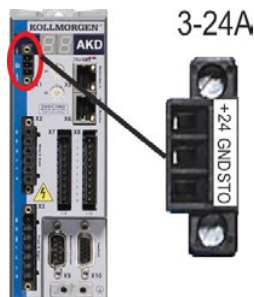

Pin	Signal	Description
1	+24	+24 VDC Auxiliary voltage
2	GND	24V Supply GND
3	STO	STO enable (Safe Torque Off)

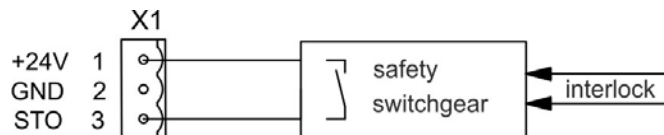

AKD-x048

Inputs STO-Enable 1/2 (X1)

- Reference ground is STO GND
- High Level 24 V ±10%, 16 to 25 mA
- Low level 0...5 VDC
- Reaction time < 10 ms
- Galvanic isolation for 250 VDC

Outputs STO-Status 1/2 (X1)

- Reference ground is STO GND
- As per EN61131-2 type 1
- Max. 30 VDC (PELV), max. 100mA
- PELV acc. to EN 60204-1
- Galvanic isolation for 250 VDC

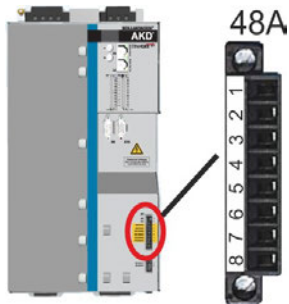

Pin	Description	Pin	Description
1	+24 VDC Auxiliary voltage	5	STO-Status 1
2	24V Supply GND	6	STO-Enable 1
3	STO +24 VDC supply voltage	7	STO-Status 2
4	STO GND	8	STO-Enable 2

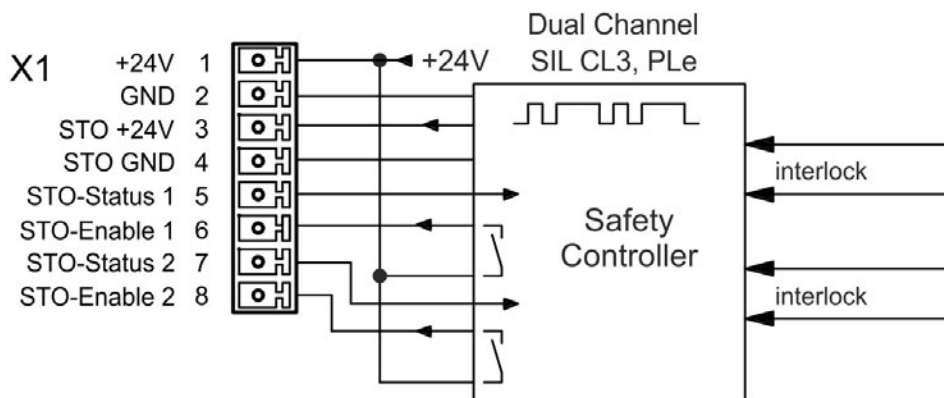
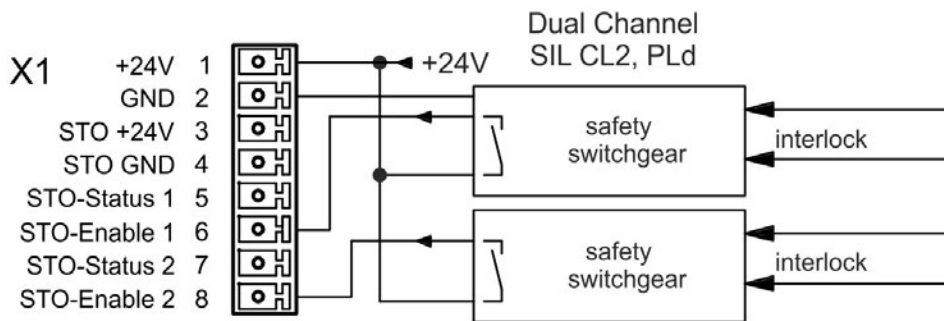
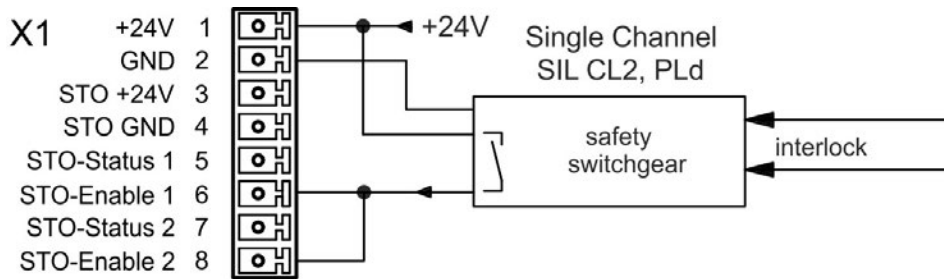

6.16.6 Enclosure, wiring

Since the drive meets IP20, you must select an enclosure that permits safe operation of the drive. The enclosure must at least meet IP54. Wiring remaining within the specified enclosure must meet the requirements of the standard IEC 60204-1 and ISO 13849-2 (Table D.4).

If you are wiring leads that are outside the specified enclosure (IP54), the cables must be laid durably (firmly), protected from outside damage (for example, by laying the cable in a duct), placed in different sheathed cables, or protected individually by grounding connection.

6.16.7 OSSD test pulses

Safety controllers usually check their outputs periodically during the normal operation. These test procedures create pulses to the STO-Enable input.

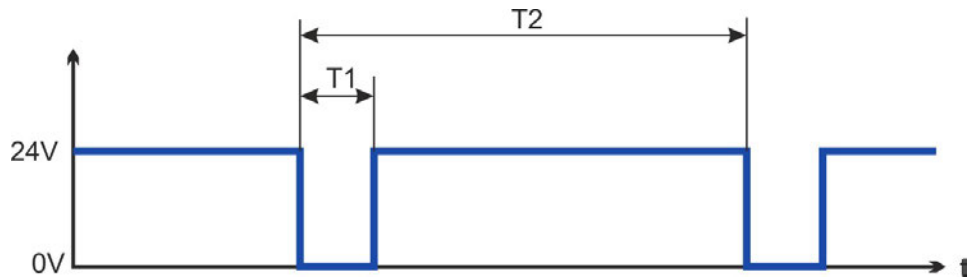

NOTE

Test pulses with $T1 \leq 300 \mu\text{s}$ and $T2 \geq 200 \text{ms}$ will not have any influence to the safety relevant STO function.

Test pulses, which are outside of this specification, will switch the STO function, but will not create a dangerous situation.

6.16.8 Functional description

When STO function (Safe Torque Off) is not needed, then STO-Enable must be connected directly with +24 V. The STO function is then bypassed and cannot be used.

If the STO function is in use, then the STO-Enable must be connected to the output of a security control or a safety relay, which at least meets the requirements of PLd, CAT 3 according to ISO 13849 (connection diagram: (→ # 60).

SIL2/PLd Single Channel Control

With the single-channel control of the STO (SIL2/PLd) safety function, STO is switched by one output of a safety switching device (e.g. safety relay). Erroneous engaging will not be recognized. Therefore the output of the control must be supervised for possible malfunction.

STO	ENABLE	Display	Motor has Torque	Safety
0 V	0 V	n602	no	yes
0 V	+24 V	F602	no	yes
+24 V	0 V	opmode	no	no
+24 V	+24 V	opmode with 'dot'	yes	no

When STO function is engaged during operation by separating input STO from 24 V, the motor slows down without control and the drive displays the fault F602.

SIL2/PLd Dual Channel Control (with AKD-x048 only)

With the dual-channel control of the STO (SIL2/PLd) safety function, the switch-off paths STO-Enable1 and STO-Enable2 are switched separately by two outputs of a safety switching device (e.g. safety relay).

STO-Enable1	STO-Enable2	ENABLE	Display	Motor has Torque	Safety
0 V	0 V	0 V	n602	no	yes
0 V	0 V	+24 V	F602	no	yes
+24 V	+24 V	0 V	opmode	no	no
+24 V	+24 V	+24 V	opmode with 'dot'	yes	no
+24 V	0 V	0 V	n602	no	no
+24 V	0 V	+24 V	F602	no	no
0 V	+24 V	0 V	n602	no	no
0 V	+24 V	+24 V	F602	no	no

SIL3/PLe Dual Channel Control (with AKD-x048 only)

With the dual-channel control of the STO safety function, the switch-off paths STO-Enable1 and STO-Enable2 are switched separately by two outputs of a safety control (logical states see table above).

NOTE

To achieve PL e or SIL CL3, the safe switching of the pulse inhibitor must be tested periodically by analyzing the STO-Status signals (→ # 62).

6.16.8.1 Signal diagram (sequence)

Single channel, AKD-x003 up to AKD-x024

The diagram below shows how to use the single channel STO function for a safe drive stop and fault free operation of the drive.

1. Brake the drive in a controlled manner (speed setpoint = 0 V).
2. When speed = 0 rpm, disable the drive (Enable = 0 V).
3. Activate the STO function (STO = 0 V)

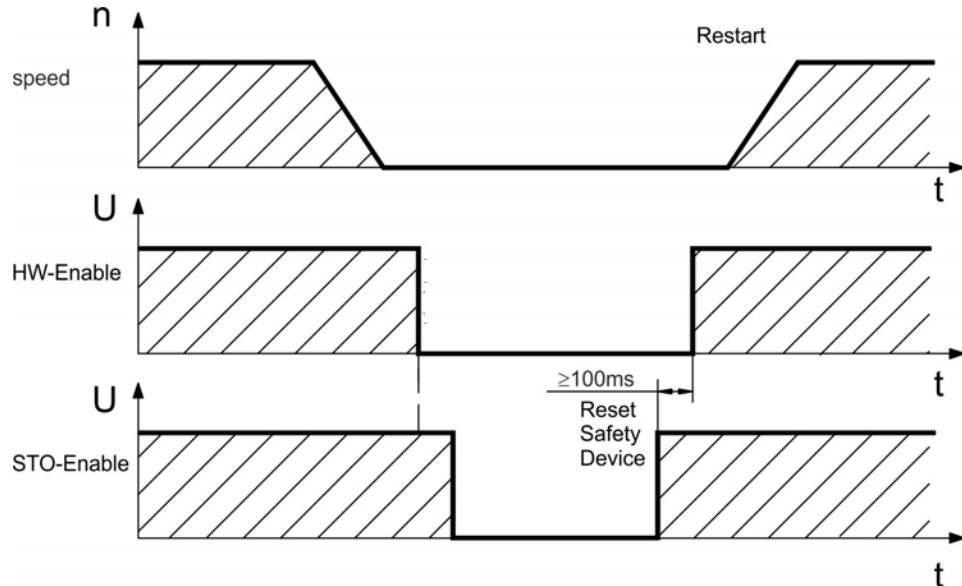

Dual channel, AKD-x048

The diagram below shows how to use the dual channel STO function for a safe drive stop and fault free operation of the drive.

1. Brake the drive in a controlled manner (speed setpoint = 0 V).
2. When speed = 0 rpm, disable the drive (Enable = 0 V).
3. Activate the STO function (STO-Enable 1 = 0 V and STO-Enable 2 = 0 V)

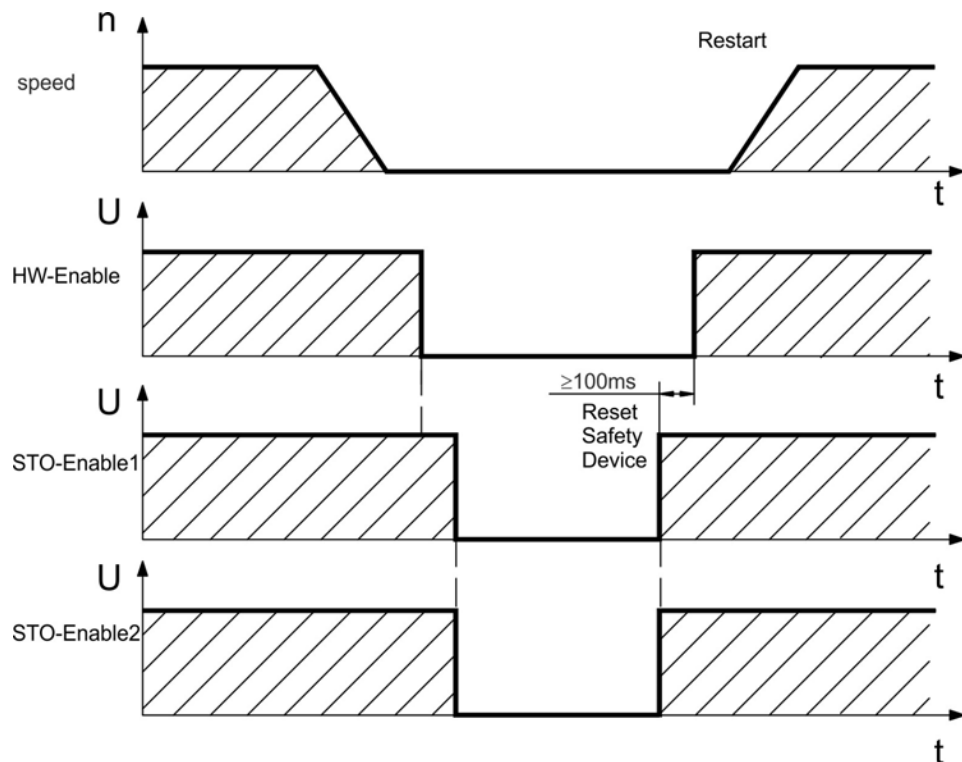

6.16.8.2 Wiring examples

Single channel SIL2/PLd with AKD-x003 to 024

The sample application below shows door guarding and emergency stop, controlled by Kollmorgen KSM safety module to switch the STO-Enable input of an AKD-x003 to 024 device to SIL2, PLd.

NOTE Review the enclosure and wiring instructions; (→ # 57).

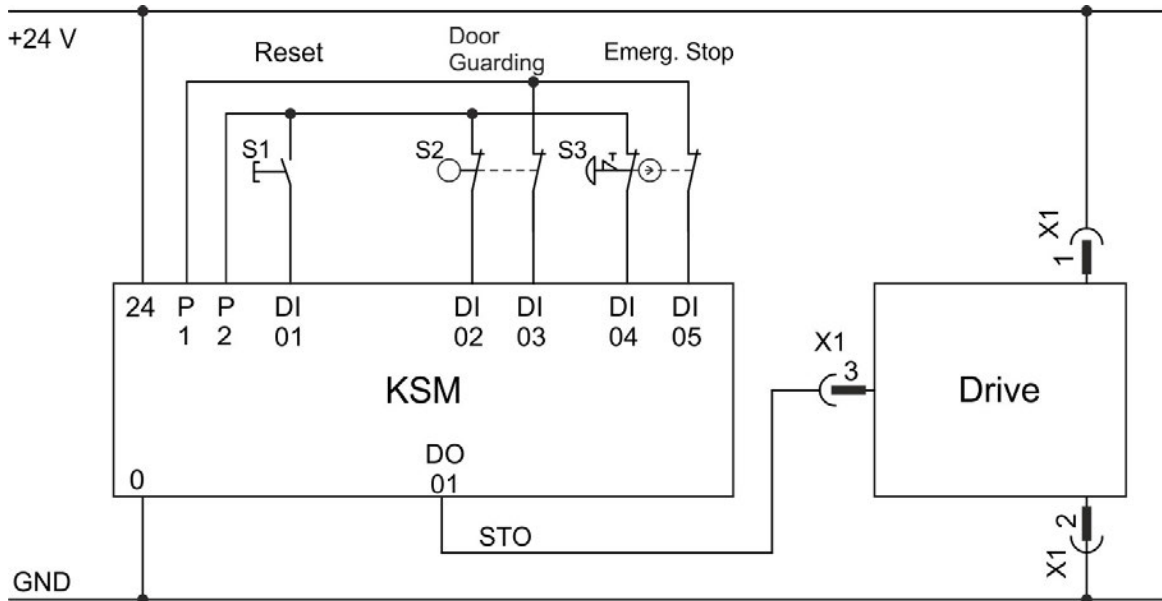

Single channel SIL2/PLd with AKD-x048

The sample application below shows door guarding and emergency stop, controlled by Kollmorgen KSM safety module to switch the STO-Enable input of an AKD-x048 device to SIL2, PLd. STO-Status signals need not to be used.

NOTE Review the enclosure and wiring instructions; (→ # 57).

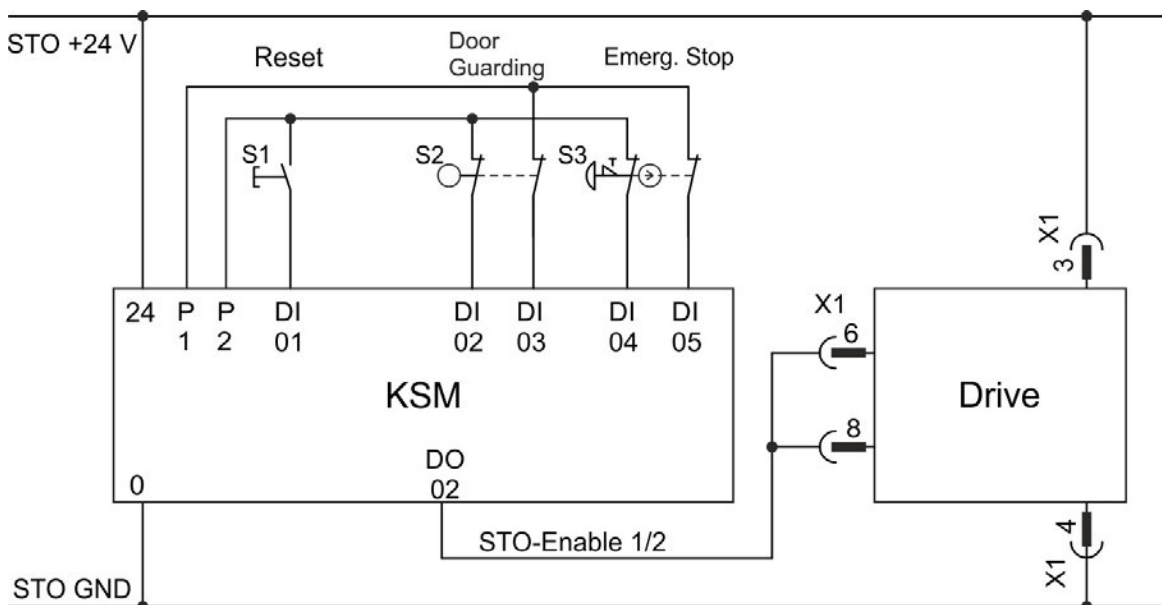

Dual channel SIL2/PLd with AKD-x048 only

The sample application below shows door guarding and emergency stop, controlled by Kollmorgen KSM safety module to switch the STO-Enable inputs of an AKD-x048 device to SIL2, PLd. STO-Status signals need not to be used.

NOTE

Review the enclosure and wiring instructions; (→ # 57).

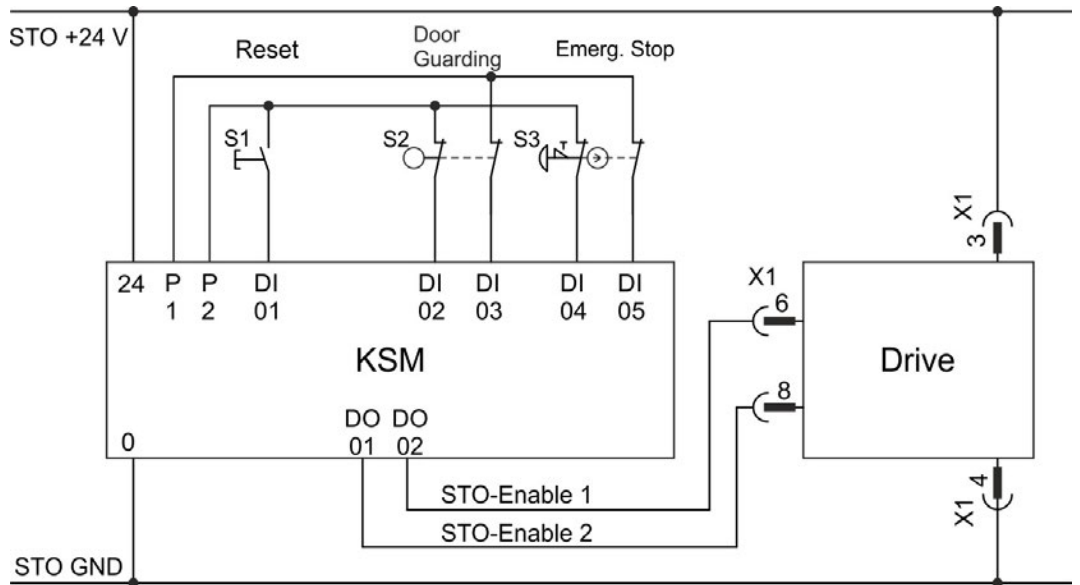

Dual channel SIL3/PLe with AKD-x048 only

The sample application below shows door guarding and emergency stop, controlled by Kollmorgen KSM safety module to switch the STO-Enable inputs of an AKD-x048 device to SIL3, PLe. The safe switching of the pulse inhibitor must be tested periodically by analyzing the STO-Status in the safety control.

NOTE

Review the enclosure and wiring instructions; (→ # 57).

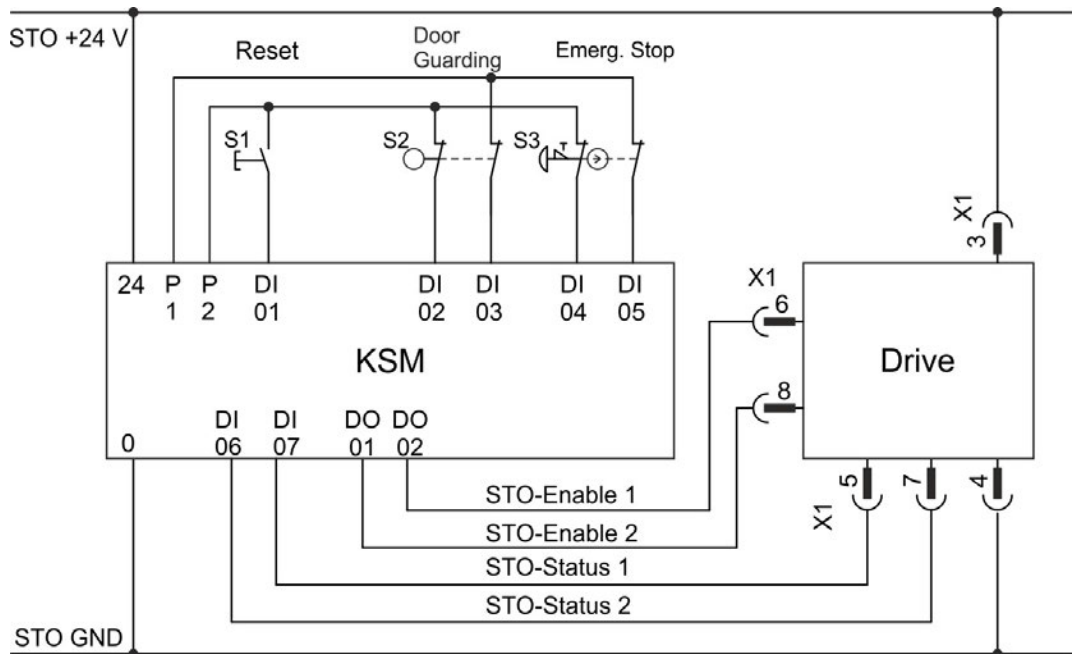

6.16.8.3 Functional test

Single Channel control and Dual Channel control, SIL CL2 / PLd

NOTICE

You must test the STO function after initial start of the drive, after each interference into the wiring of the drive, or after exchange of one or several components of the drive.

Method 1, drive remain enabled	Method 2, drive disabled
<ol style="list-style-type: none"> 1. Stop drive, with setpoint 0V. Keep drive enabled. <p>DANGER: Do not enter hazardous area!</p> <ol style="list-style-type: none"> 2. Activate the STO function for example by opening protective screen. 3. The fault contact opens, the net contactor releases, and the drive displays fault F602. 	<ol style="list-style-type: none"> 1. Stop all drives, with setpoint 0V, disable drive (Enable=0V). 2. Activate the STO function, for example, by opening protective screen 3. The drive displays warning n602.

Dual Channel control, SIL CL3 / PLe

NOTICE

To achieve PLe / SIL CL3, the safe switching of the pulse inhibitor must be tested periodically by analyzing the feedback signal from a safety control:

- at the start of a system,
- at the restart after triggering a protective device,
- at least every 8 hours by the operator.

The inputs STO-ENABLE 1 and STO-ENABLE 2 are switched in turns according to a defined test sequence. The switching state of the pulse inhibitor is available at the STO-Status outputs of the AKD and must be analyzed to achieve a sufficient diagnostic cover ratio:

- Diagnostic with external not safe controller, test with dynamic sequence:
 - test cycle: with each device start, minimum once per day.
 - diagnostic cover ratio: 60 %
- Diagnostic with external safe controller, test with dynamic sequence.
 - test cycle: with each device start, minimum once per day.
 - diagnostic cover ratio: 90 %

The test sequence for the functional test of the safe pulse inhibitor must be performed as shown in the following time diagram.

Start conditions of the test sequence:

- Operational readiness FAULT = "1"
- Enable signal ENABLE = "0"
- STO-ENABLE 1 = "0" and STO-ENABLE 2 = "0"

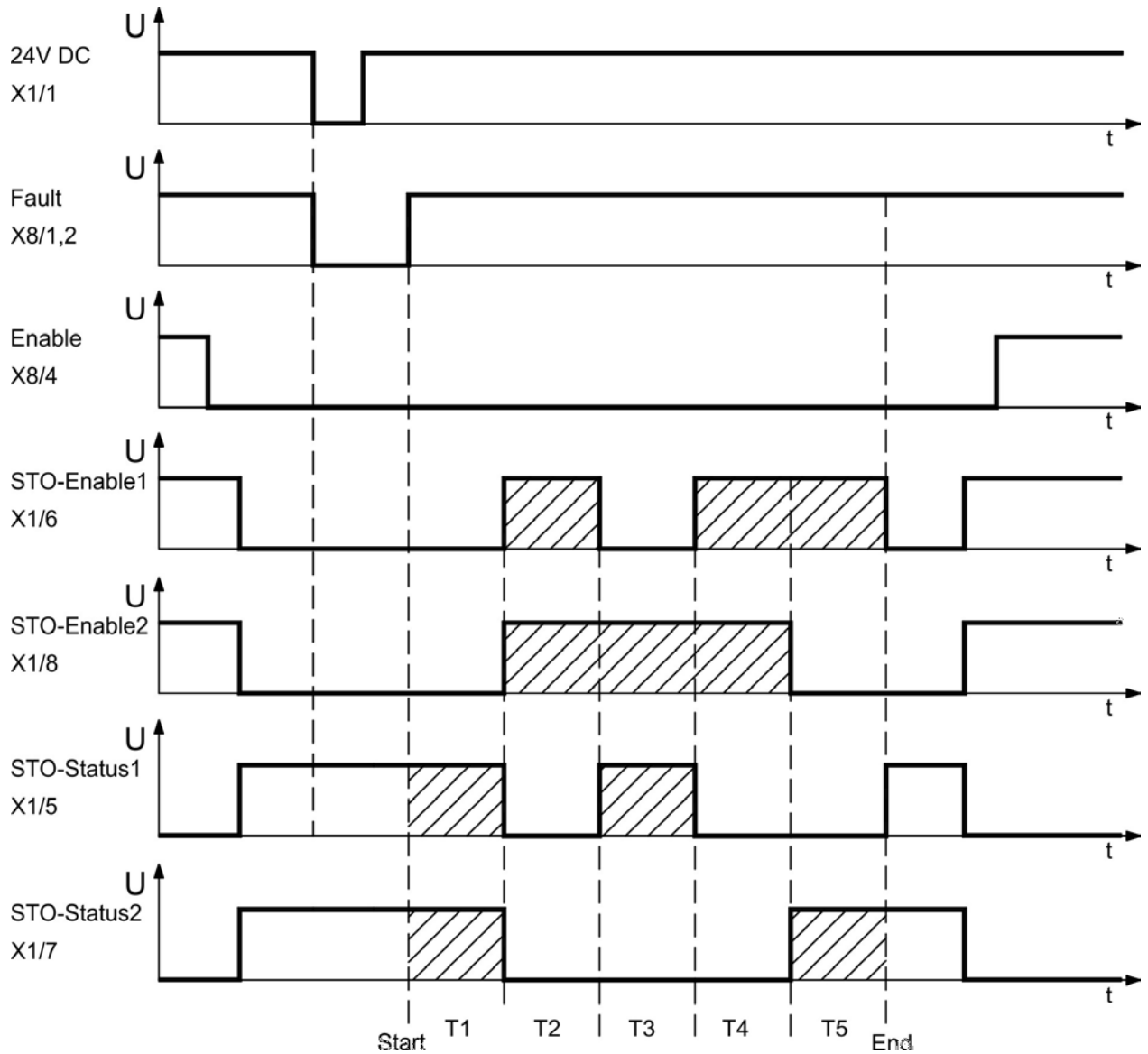

Legend:

- FAULT: relay output, 1=ready to operate
- STO-ENABLE 1: digital input, 1st switch-off path
- STO-ENABLE 2: digital input, 2nd switch-off path
- STO-STATUS 1: digital output, switching state of 1st pulse inhibitor
- STO-STATUS 2: digital output, switching state of 2nd pulse inhibitor
- T1 ... T5: Test sequence
- Start: Start of test sequence
- End: End of test sequence

6.17 Shock-hazard Protection

6.17.1 Leakage current

Leakage current via the PE conductor results from the combination of equipment and cable leakage currents. The leakage current frequency pattern includes a number of frequencies, whereby the residual-current circuit breakers definitively evaluate the 50 Hz current. For this reason, the leakage current cannot be measured using a conventional multimeter. As a rule of thumb, the following assumption can be made for leakage current on our low-capacity cables at a mains voltage of 400 V, depending on the clock frequency of the output stage:

$I_{\text{leak}} = n \times 20 \text{ mA} + L \times 1 \text{ mA/m}$ at 8 kHz clock frequency at the output stage

$I_{\text{leak}} = n \times 20 \text{ mA} + L \times 2 \text{ mA/m}$ at a 16 kHz clock frequency at the output stage

(where I_{leak} =leakage current, n =number of drives, L =length of motor cable)

At other mains voltage ratings, the leakage current varies in proportion to the voltage.

Example: 2 x drives + a 25m motor cable at a clock frequency of 8 kHz:

$2 \times 20 \text{ mA} + 25 \text{ m} \times 1 \text{ mA/m} = 65 \text{ mA}$ leakage current.

NOTE

Since the leakage current to PE is more than 3.5 mA, in compliance with IEC61800-5-1 the PE connection must either be doubled or a connecting cable with a cross-section $> 10 \text{ mm}^2$ must be used. Use the PE terminal and the PE connection screws in order to fulfill this requirement.

The following measures can be used to minimize leakage currents:

- Reduce the length of the engine cable.
- Use low-capacity cables (→ # 40).

6.17.2 Residual current protective device (RCD)

In conformity with IEC 60364-4-41 – Regulations for installation and IEC 60204 – Electrical equipment of machinery, residual current protective devices (RCDs) can be used provided the requisite regulations are complied with. The AKD is a 3-phase system with a B6 bridge. Therefore, RCDs which are sensitive to all currents must be used in order to detect any DC fault current. Refer to the chapter above for the rule of thumb for determining the leakage current. Rated residual currents in the RCDs:

10 to 30 mA	Protection against "indirect contact" (personal fire protection) for stationary and mobile equipment, as well as for "direct contact".
50 to 300 mA	Protection against "indirect contact" (personal fire protection) for stationary equipment

NOTE

Recommendation: In order to protect against direct contact (with motor cables shorter than 5 m) Kollmorgen recommends that each drive be protected individually using a 30 mA RCD which is sensitive to all currents.

If you use a selective RCD, the more intelligent evaluation process will prevent spurious tripping of the RCD.

6.17.3 Isolating transformers

When protection against indirect contact is absolutely essential despite a higher leakage current, or when an alternative form of shock-hazard protection is sought, the AKD can also be operated via an isolating transformer (schematic connection (→ # 101). A ground-leakage monitor can be used to monitor for short circuits.

NOTE

Keep the length of wiring between the transformer and the drive as short as possible.

7 Mechanical Installation

7.1 Important Notes	66
7.2 Guide to Mechanical Installation	66
7.3 Mechanical Drawings Standard Width	67
7.4 Mechanical Drawings Extended Width	71

7.1 Important Notes



CAUTION

There is a danger of electrical shock by high EMC level which could result in injury, if the drive (or the motor) is not properly EMC-grounded. Electrically-conductive back panels such as aluminum or galvanized steel are preferred. For painted and other coated metal panels, remove all coating behind the drive.

NOTICE

Protect the drive from impermissible stresses. In particular, do not let any components become bent or any insulation distances altered during transport and handling. Avoid contact with electronic components and contacts.

NOTICE

The drive will switch itself off in case of overheating. Ensure that there is an adequate flow of cool, filtered air into the bottom of the control cabinet, or use a heat exchanger (→ # 33).

NOTICE

Do not mount devices that produce magnetic fields directly beside the drive. Strong magnetic fields can directly affect internal components. Install devices which produce magnetic field with distance to the drives and/or shield the magnetic fields.

7.2 Guide to Mechanical Installation

The following tools are required (at a minimum) to install the AKD; your specific installation may require additional tools:

- M4 hexagon socket-cap screws (ISO 4762)
- 3 mm T-handle Allen key
- No. 2 Phillips head screwdriver
- Small slotted screwdriver

Dimensions and mounting hole positions depend on the drive variant:

Drive Variant	Housing
AKD-B, -P, -T	Standard width, (→ # 67)
AKD-T-IC, -M-MC, -M-M1	Extended width, (→ # 71)

Install the drive unit as follows:

1. Prepare the site.
Mount the drive in a closed control cabinet (→ # 33). The site must be free from conductive or corrosive materials. For the mounting position in the cabinet (→ # 67)ff respectively (→ # 71)ff.
2. Check ventilation.
Check that the ventilation of the drive is unimpeded, and keep within the permitted ambient temperature (→ # 33). Keep the required space clearance above and below the drive (→ # 67)ff respectively (→ # 71)ff.
3. Check cooling system.
If cooling systems are used for the control cabinet, position the cooling system so that condensation water cannot drip onto the drive or peripheral devices.
4. Mount the drive.
Assemble the drive and power supply near each other on the conductive, grounded mounting plate in the cabinet.
5. Ground the drive.
For EMC-compliant shielding and grounding, (→ # 97). Ground the mounting plate, motor housing and CNC-GND of the control system.

7.3 Mechanical Drawings Standard Width

7.3.1 Control cabinet layout AKD-xzzz06, standard width

Material: M4 hexagon socket screws to ISO 4762, 3 mm T-handle Allen key

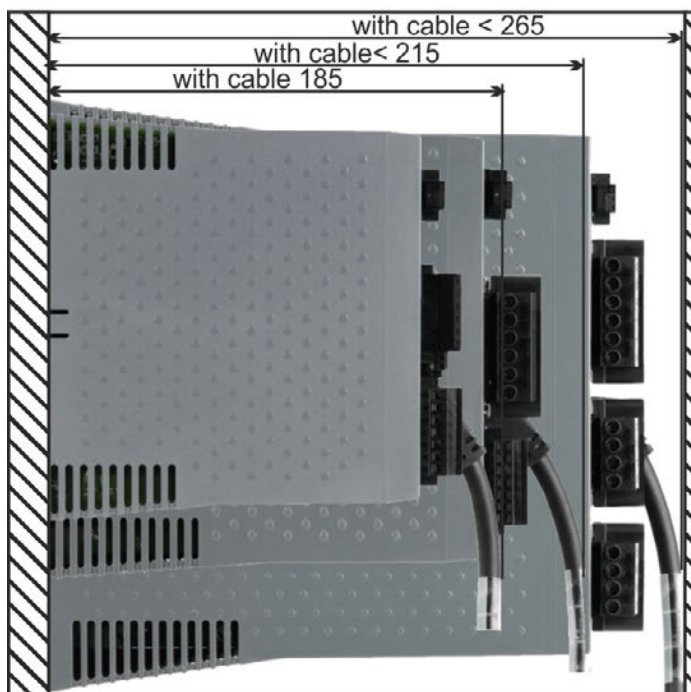
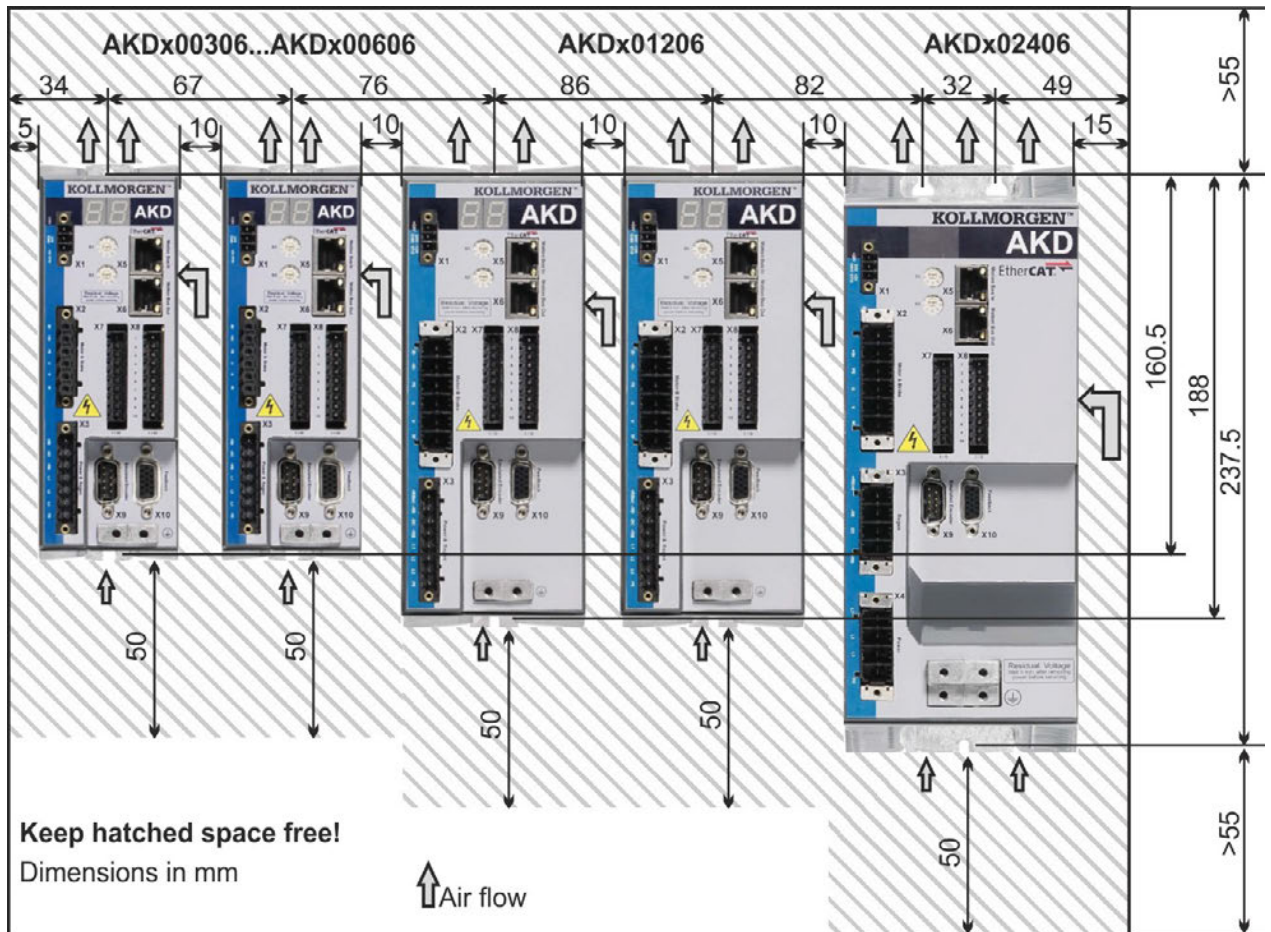

7.3.2 Control cabinet layout AKD-xzzz07, standard width

Material: M4 hexagon socket screws to ISO 4762, 3 mm T-handle Allen key

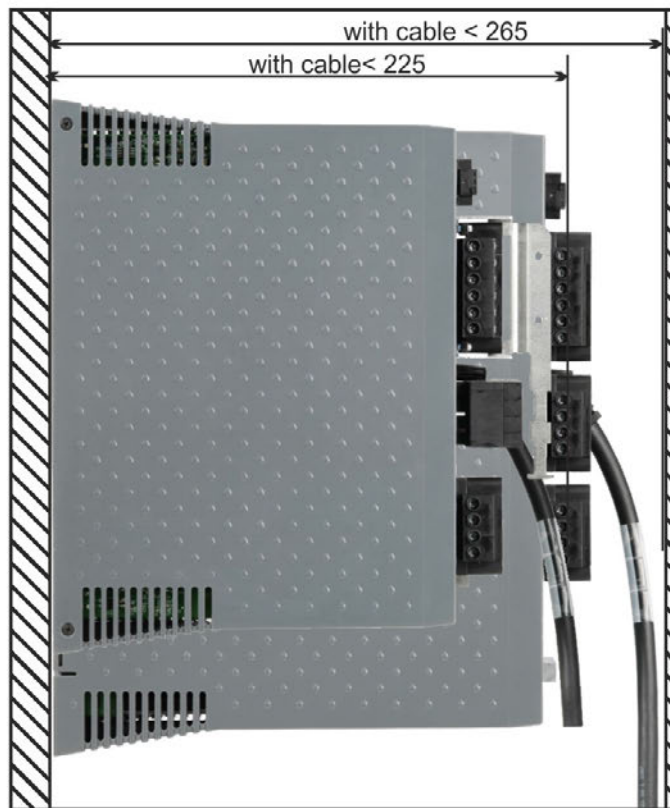
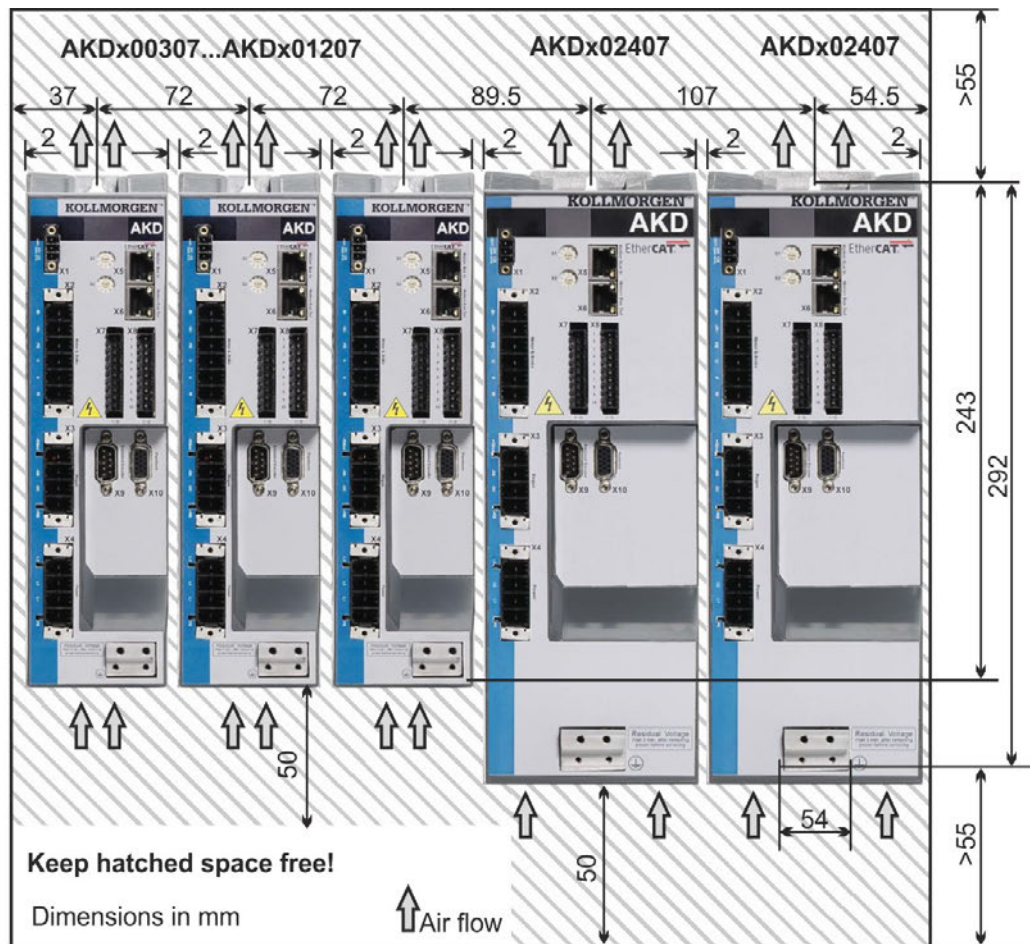

7.3.3 Dimensions AKD-xzzz06, standard width

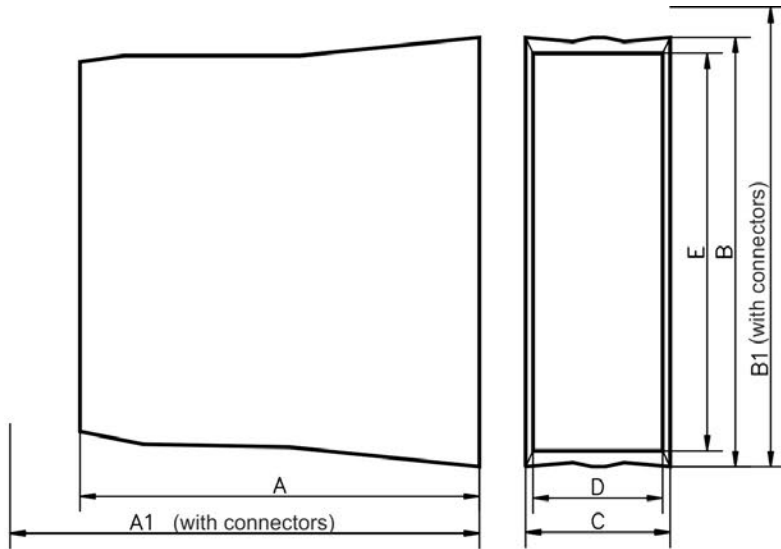

Standard Width 110 - 230V	A	A1	B	B1	C	D	E
	mm	mm	mm	mm	mm	mm	mm
AKD 3A, 6A	156	185	168	200	59	54	150
AKD 12A	187	215	196	225	78.4	72	177
AKD 24A	228	265	248	280	100	96	217

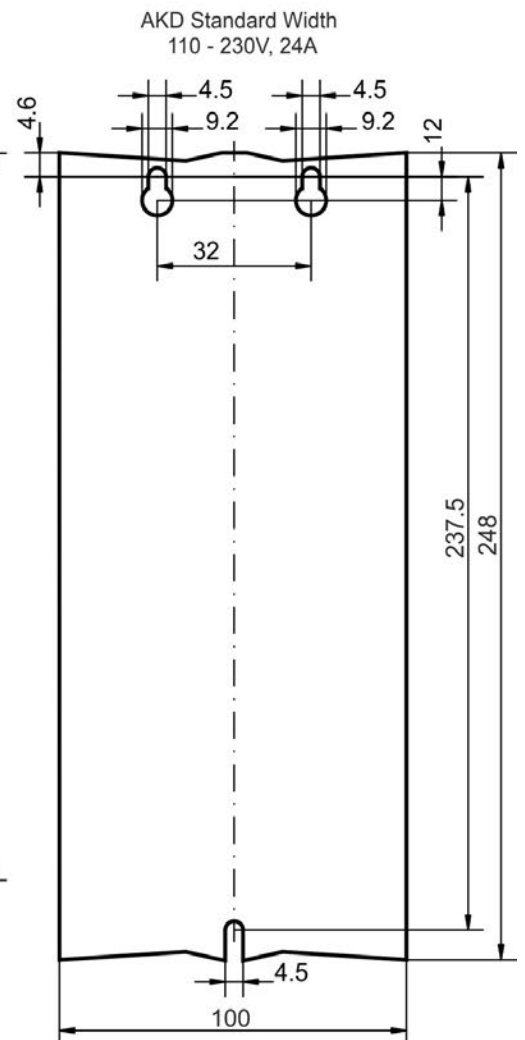
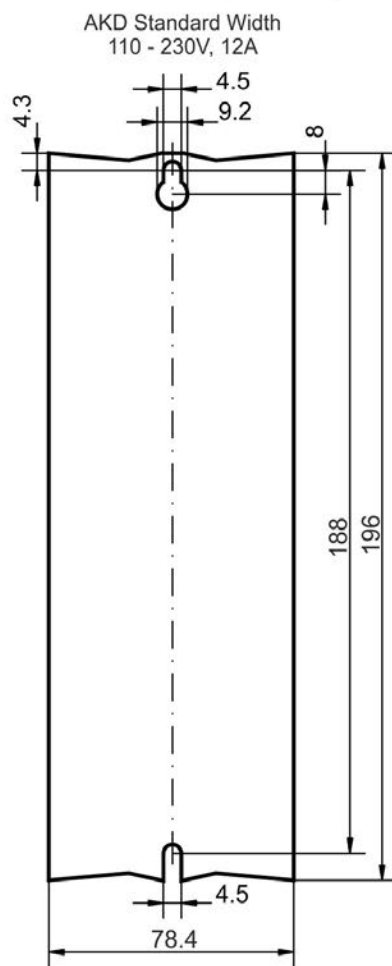
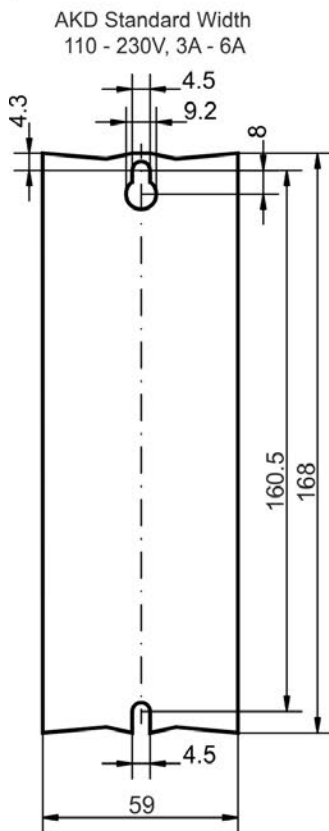

7.3.4 Dimensions AKD-xzzz07, standard width

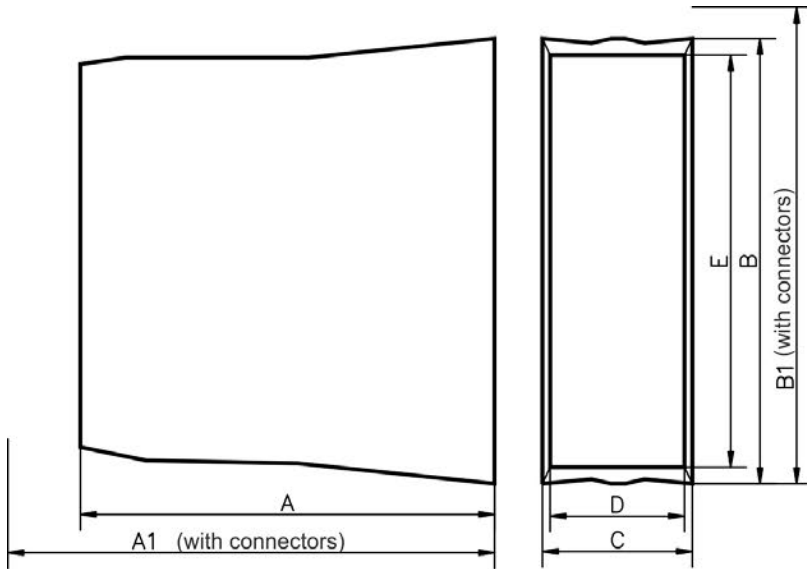

Standard Width 480V	A	A1	B	B1	C	D	E
	mm	mm	mm	mm	mm	mm	mm
AKD 3A, 6A, 12A	185	221	256	290	70	65	232
AKD 24A	228	264	306	340	105	99	273
AKD 48A	225	264	385	526	185	181	320

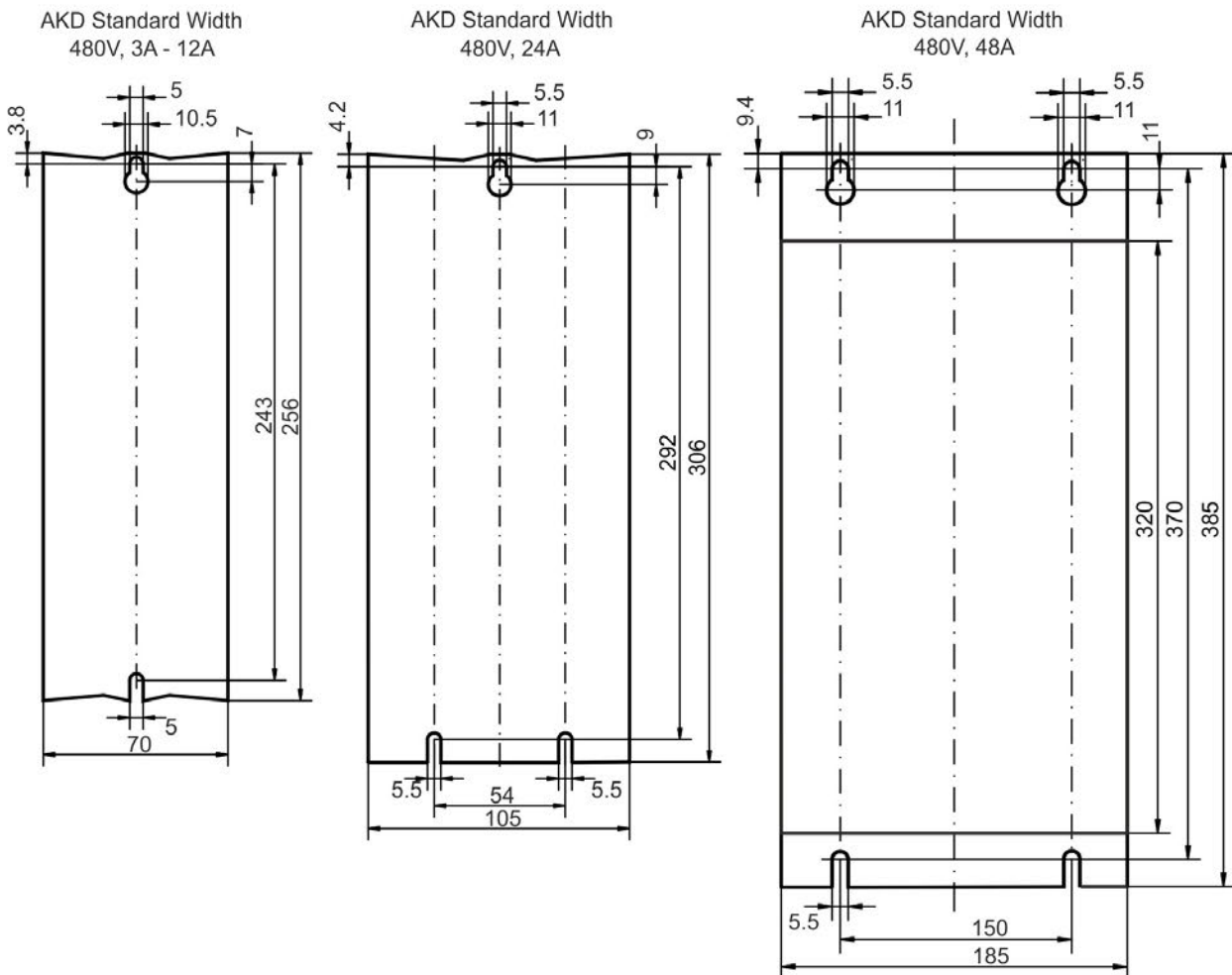

7.4 Mechanical Drawings Extended Width

7.4.1 Control cabinet layout, example with AKD-M00306

Material: M4 hexagon socket screws to ISO 4762, 3 mm T-handle Allen key

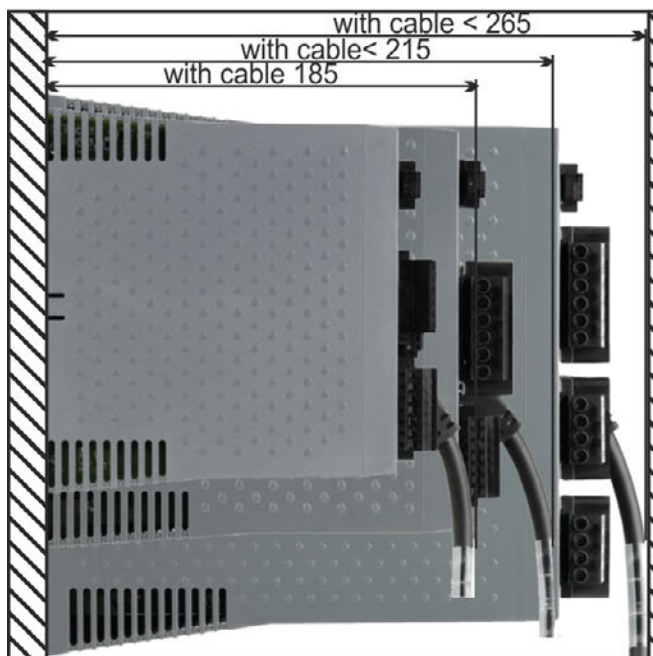
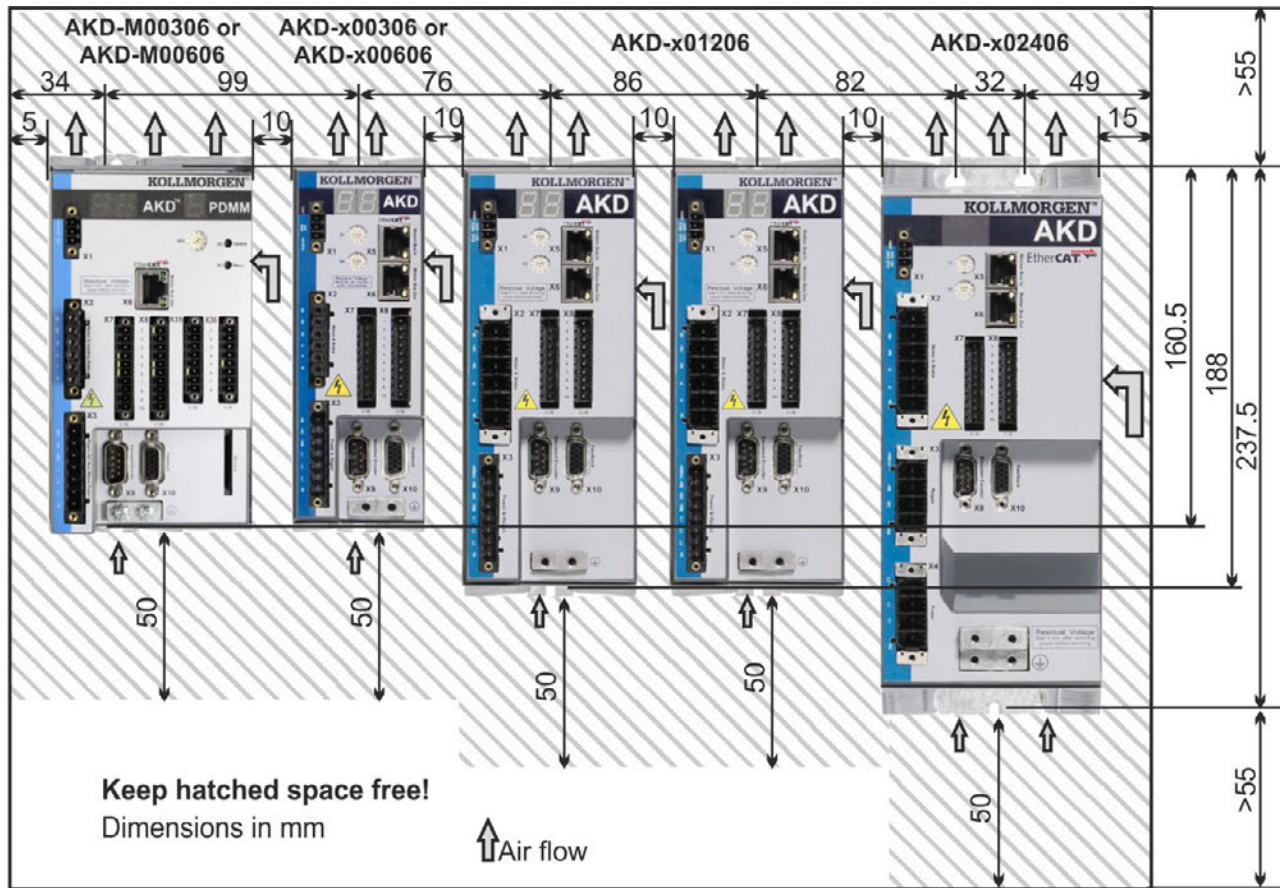

7.4.2 Control cabinet layout, example with AKD-M00307

Material: M4 hexagon socket screws to ISO 4762, 3 mm T-handle Allen key

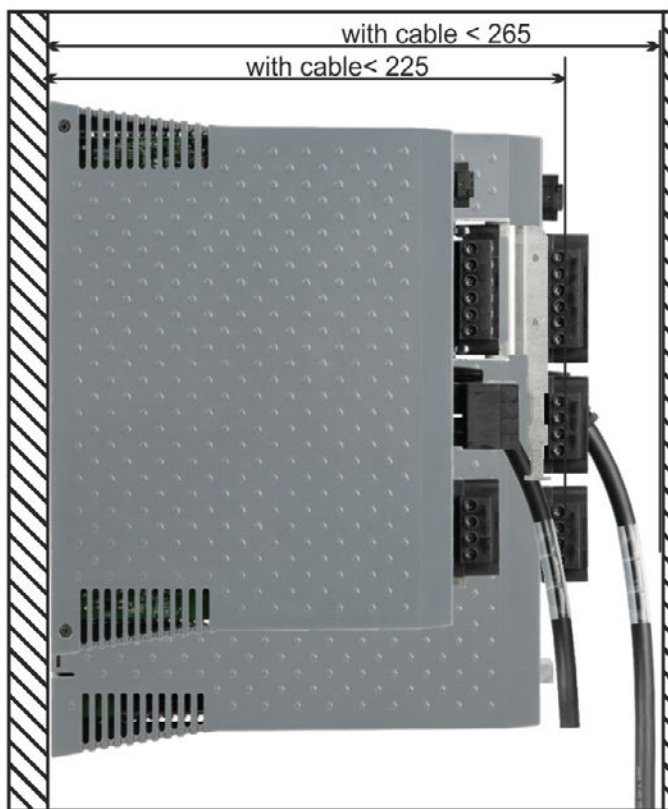
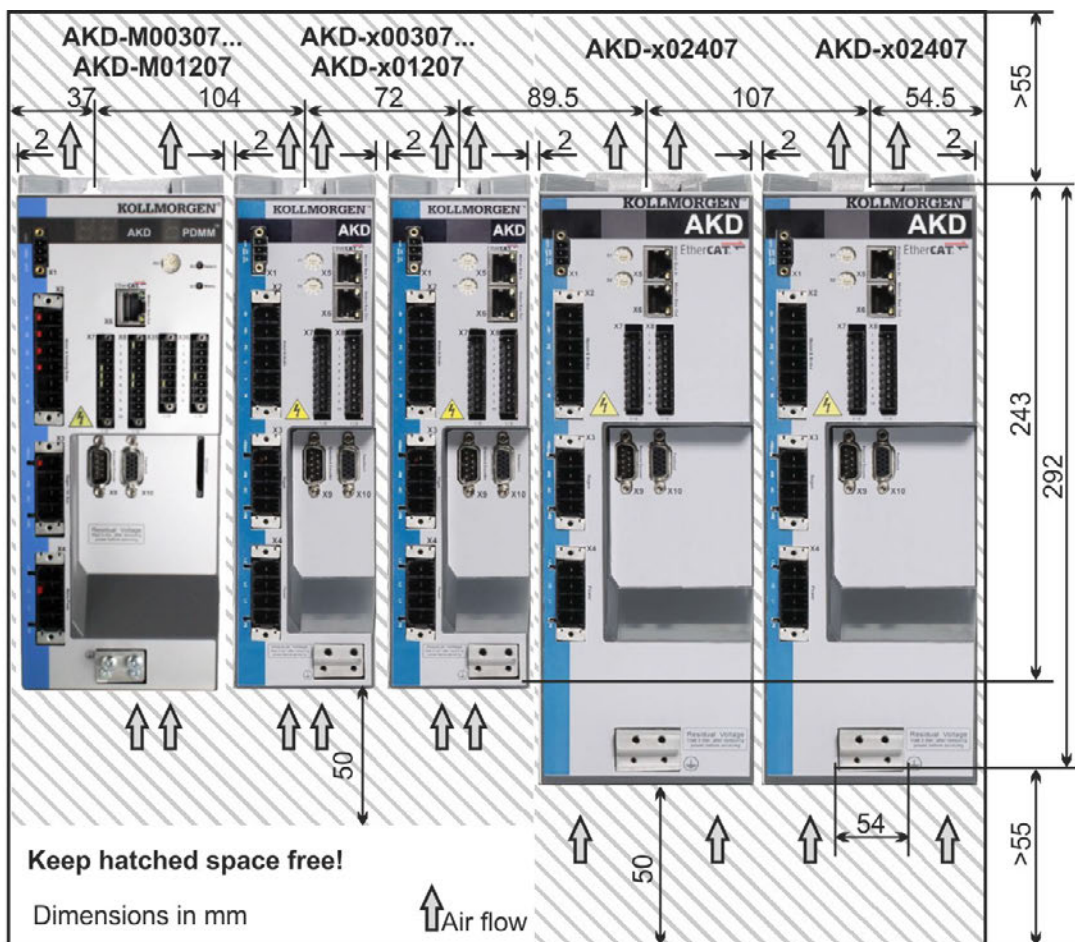

7.4.3 Dimensions AKD-xzzz06, extended width

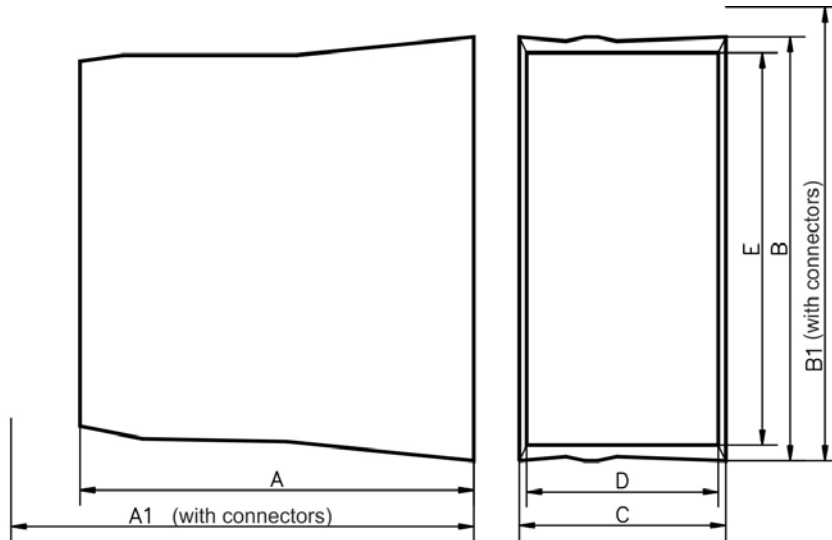

Extended Width 110 to 230V	A	A1	B	B1	C	D	E
	mm	mm	mm	mm	mm	mm	mm
AKD 3A, 6A	156	185	168	200	89	84	150
AKD 12A	187	215	196	225	96	91	177
AKD 24A	228	258	248	278	100	96	217

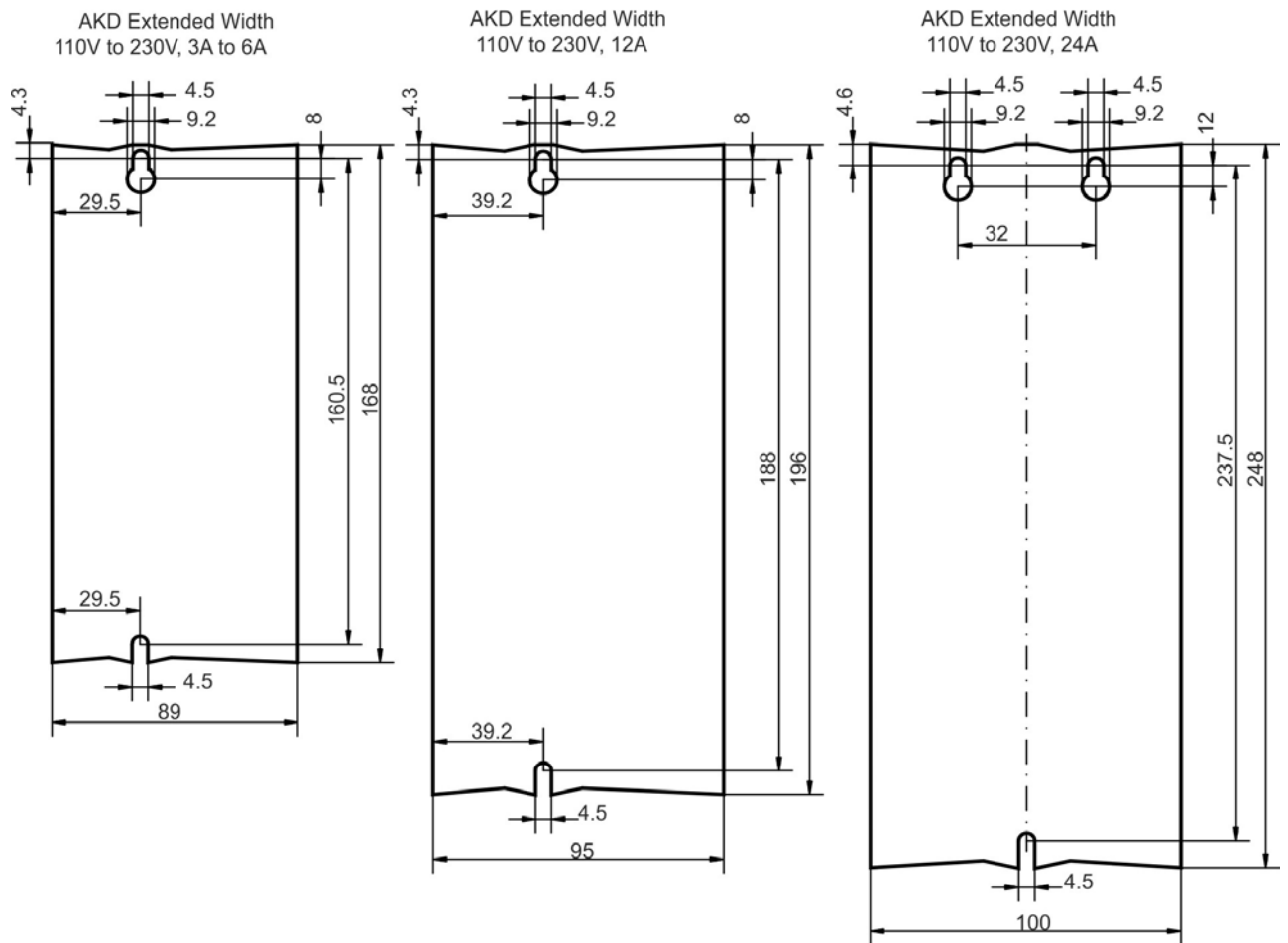

7.4.4 Dimensions AKD-xzzz07, extended width

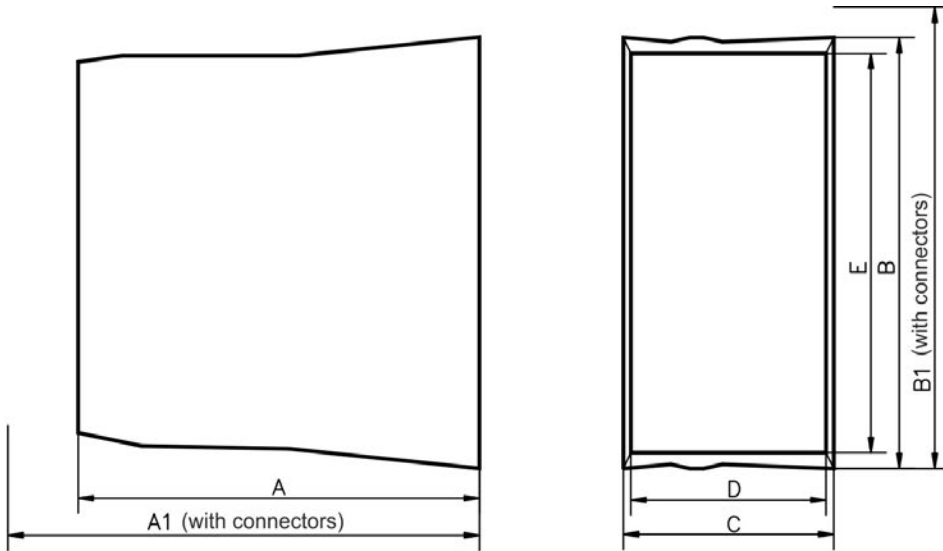

Extended Width 480V	A	A1	B	B1	C	D	E
	mm	mm	mm	mm	mm	mm	mm
AKD 3A, 6A, 12A	185	221	256	290	100	95	232
AKD 24A	228	264	306	340	105	99	273
AKD 48A	225	264	385	526	185	181	320

AKD Extended Width
480V, 3A - 12A

AKD Extended Width
480V, 24A

AKD Extended Width
480V, 48A

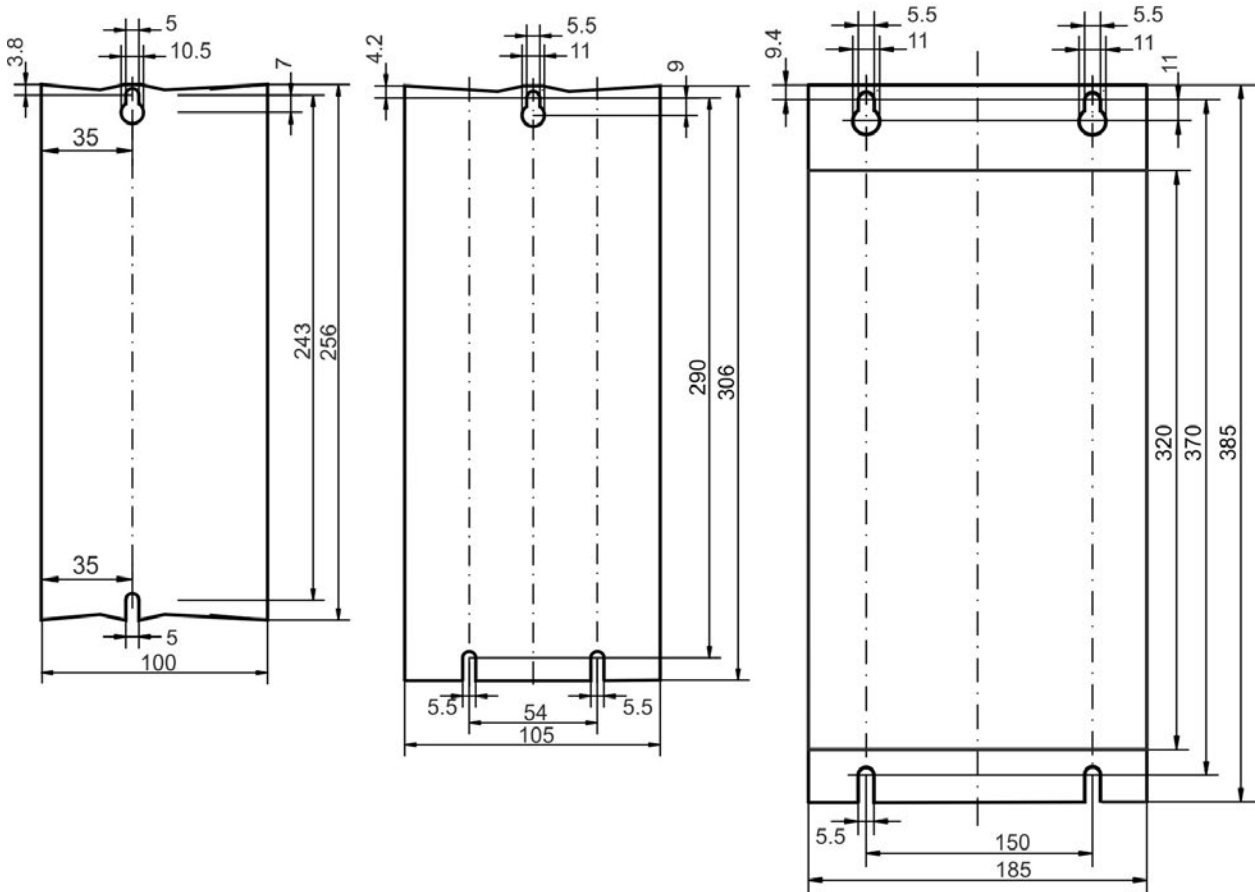

8 Electrical Installation

8.1	Important Notes	76
8.2	Guide to electrical installation	77
8.3	Wiring	78
8.4	Components of a servosystem	79
8.5	Connection Overview AKD-B, AKD-P, AKD-T	81
8.6	Connection Overview AKD-M	89
8.7	EMI Noise Reduction	97
8.8	Electrical Supply Connection	101
8.9	DC Bus link (X3, X14)	106
8.10	Motor Power Connection (X2)	114
8.11	Motor Brake Connection (X2, X15, X16)	116
8.12	Feedback Connection (X10, X9, X7)	119
8.13	Electronic gearing, Master-slave operation (X9, X7)	136
8.14	I/O Connection	144
8.15	LED display	162
8.16	Rotary Switches (S1, S2, RS1)	163
8.17	Pushbuttons (B1, B2, B3)	164
8.18	SD Card Slot	166
8.19	Service Interface (X11, X32)	168
8.20	CAN-Bus Interface (X12/X13)	172
8.21	Motion Bus Interface (X5/X6/X11)	177

8.1 Important Notes



DANGER

Never remove electrical connections to the drive while it is live. There is a danger of electrical arcing with damage to contacts and serious personal injury. Wait at least seven minutes after disconnecting the drive from the main supply power before touching potentially live sections of the equipment (e.g. contacts) or undoing any connections.

Capacitors can still have dangerous voltages present up to 7 minutes after switching off the supply power. To be sure, measure the voltage in the DC bus link and wait until it has fallen below 50 V.

Control and power connections can still be live, even if the motor is not rotating.

NOTICE

Wrong mains voltage, unsuitable motor or wrong wiring will damage the drive. Check the combination of drive and motor. Compare the rated voltage and current of the units. Implement the wiring according to the connection diagram : (→ # 82).

Make sure that the maximum permissible rated voltage at the terminals L1, L2, L3 or +DC, – DC is not exceeded by more than 10% even in the most unfavorable circumstances (see IEC 60204-1).

NOTICE

Excessively high external fusing will endanger cables and devices. The fusing of the AC supply input and 24 V supply must be installed by the user, best values (→ # 38). Hints for use of Residual-current circuit breakers (RCD) (→ # 64).

NOTICE

The drive status must be monitored by the PLC to acknowledge critical situations. Wire the FAULT contact in series into the emergency stop circuit of the installation. The emergency stop circuit must operate the supply contactor.

NOTE

It is permissible to use the setup software to alter the settings of the drive. Any other alterations will invalidate the warranty.

8.2 Guide to electrical installation

Install the drive electrical system as follows:

1. Select cables in accordance with IEC 60204 (→ # 40).
2. Install shielding and ground the drive.
For EMC-compliant shielding and grounding, see (→ # 97)(→ # 82) ff.
Ground the mounting plate, motor housing and CNC-GND of the control system.
3. Wire the drive and connectors.
Observe the "Recommendations for EMI noise reduction": (→ # 97)
 - Wire the FAULT contact in series into the emergency stop circuit of the system.
 - Connect the digital control inputs and outputs.
 - Connect up analog ground (also if fieldbuses are used).
 - Connect the analog input source, if required.
 - Connect the feedback device.
 - Connect the hardware option.
 - Connect the motor cable
 - Connect shielding at both ends. Use a motor choke if cable > 25m.
 - Connect motor-holding brake, connect shielding at both ends.
 - If required, connect the external regen resistor (with fusing).
 - Connect the auxiliary supply (maximum permissible voltage values see electrical data (→ # 35) or (→ # 36).
 - Connect the mains filter with AKD-xzzz06 (shielded lines between filter and drive).
 - Connect the main electrical supply.
Check maximum permitted voltage value (→ # 35) or (→ # 36).
 - Check proper use of residual-current circuit breakers (RCD): (→ # 64)
 - Connect the PC (→ # 168) for setting up the drive.
4. Check the wiring against the wiring diagrams.

8.3 Wiring

The installation procedure is described as an example. A different procedure may be appropriate or necessary, depending on the application of the equipment. Kollmorgen can provide training courses for this procedure upon request.



DANGER

There is a danger of electrical arcing which can cause serious personnel injury. Only install and wire the equipment when it is not live, that is, when neither the electrical supply nor the 24 V auxiliary voltage nor the supply voltages of any other connected equipment is switched on.

Make sure that the cabinet is safely disconnected (for instance, with a lock-out and warning signs). The individual voltages are switched on for the first time during setup.

NOTICE

Only professional staff who are qualified in electrical engineering are allowed to install the drive. Wires with color green with one or more yellow stripes must not be used other than for protective earth (PE) wiring.

NOTE

The ground symbol, which you will find in all the wiring diagrams, indicates that you must take care to provide an electrically conductive connection with the largest feasible surface area between the unit indicated and the mounting plate in the control cabinet. This connection is for the effective grounding of HF interference, and must not be confused with the PE-symbol (PE = protective earth, safety measure as per IEC 60204).

Use the following connection diagrams:

Overview (all connections):

- AKD-B/P/T variant	(→ # 82) ff
- AKD-M variant	(→ # 90) ff
Shielding:	(→ # 97)
Mains power:	(→ # 104)
DC Bus Link:	(→ # 106)
Motor:	(→ # 114)
Feedback:	(→ # 119)
Electronic gearing:	(→ # 136)
Encoder emulation:	(→ # 138)
Digital and analog inputs and outputs:	(→ # 144)
Service interface:	(→ # 168)
CAN-Bus interface:	(→ # 172)
Motion bus interface	(→ # 177)

8.4 Components of a servosystem

With AKD-xzzz06

NOTE

Cables drawn bold are shielded. Electrical ground is drawn with dash-dotted lines. Optional devices are connected with dashed lines to the drive. The required accessories are described in the accessories manual.

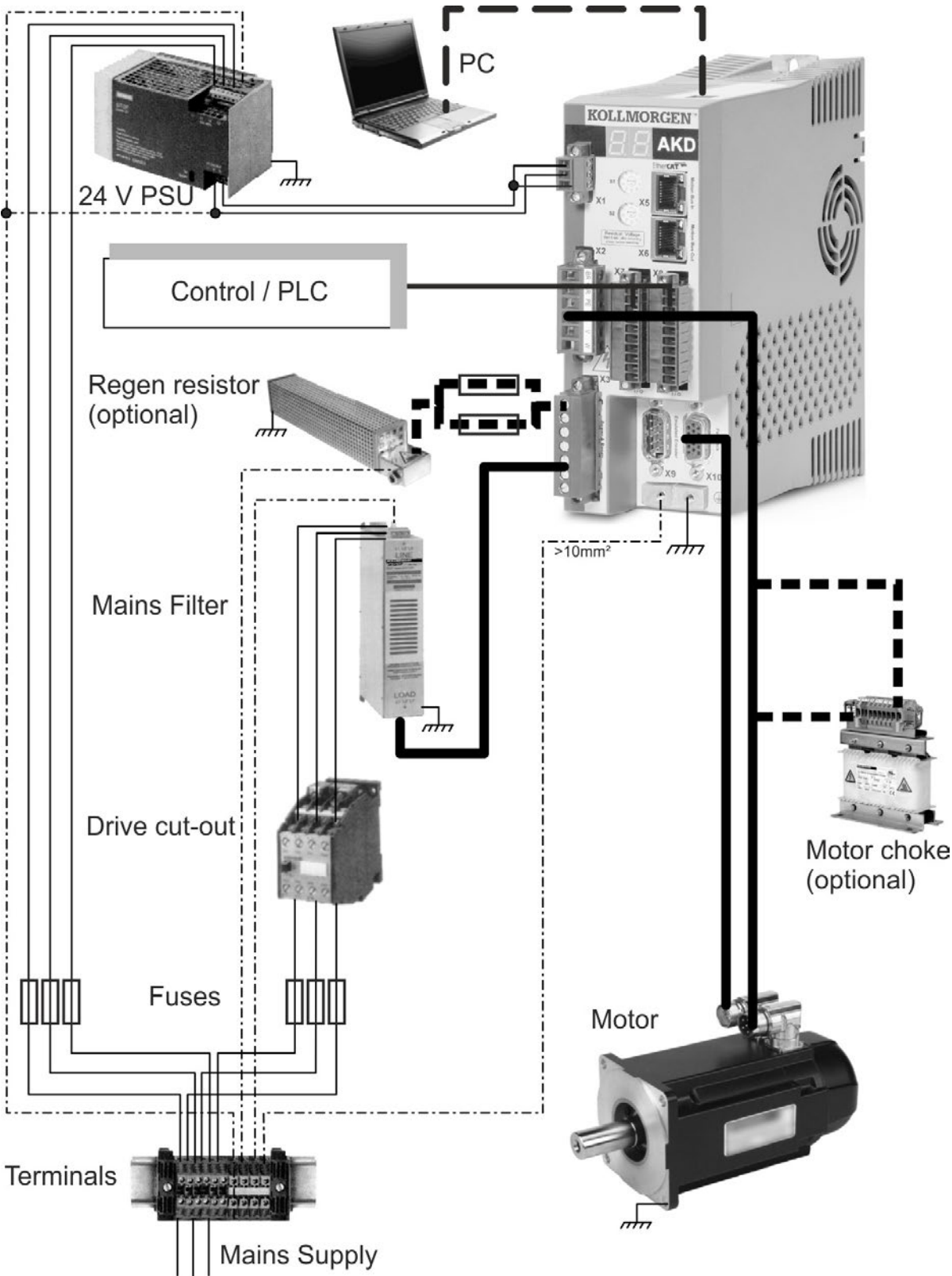

With AKD-xzzz07

NOTE

Cables drawn bold are shielded. Electrical ground is drawn with dash-dotted lines. Optional devices are connected with dashed lines to the drive. The required accessories are described in the accessories manual.

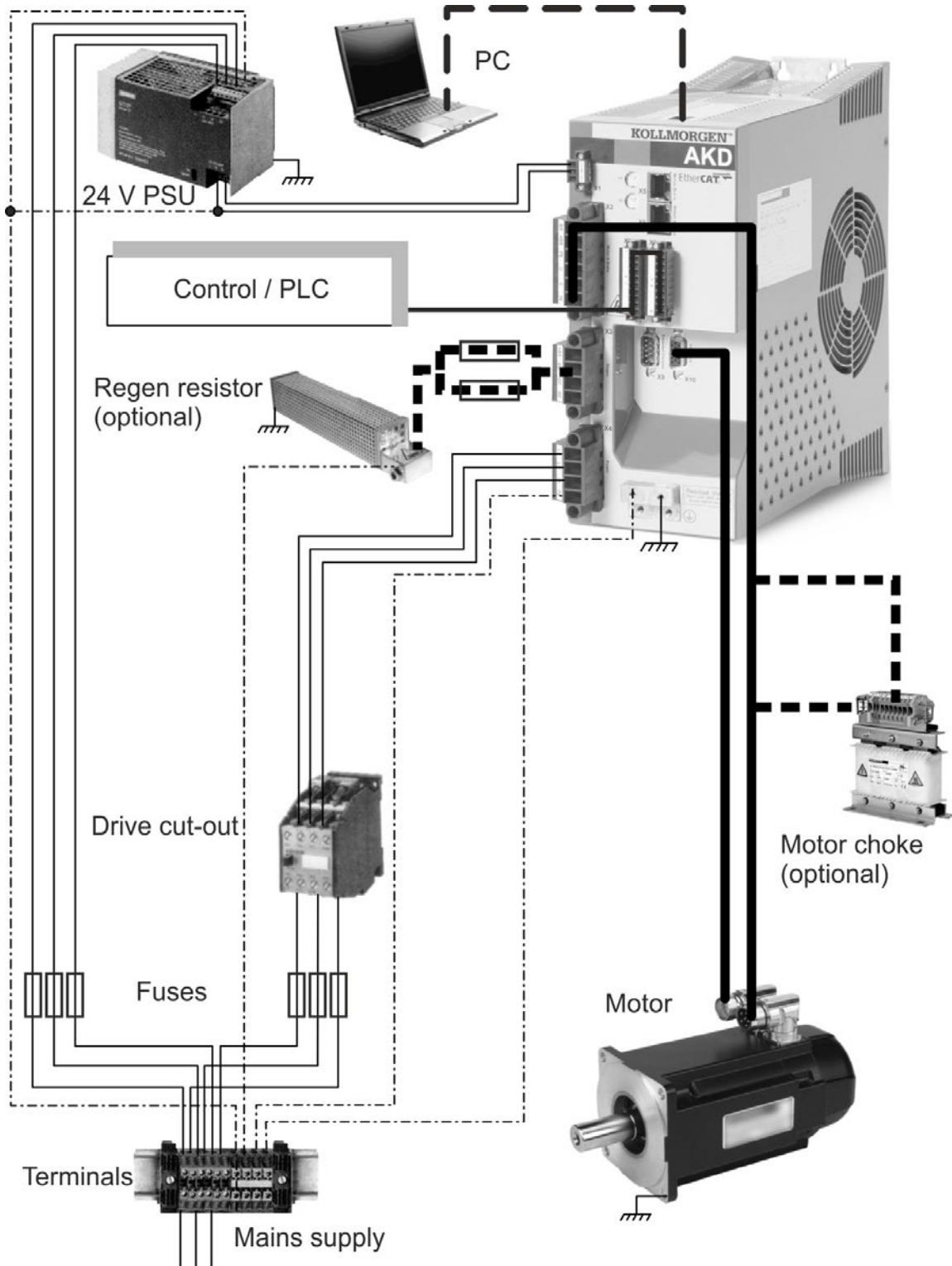

8.5 Connection Overview AKD-B, AKD-P, AKD-T

8.5.1 Connector assignment AKD-x00306, AKD-x00606

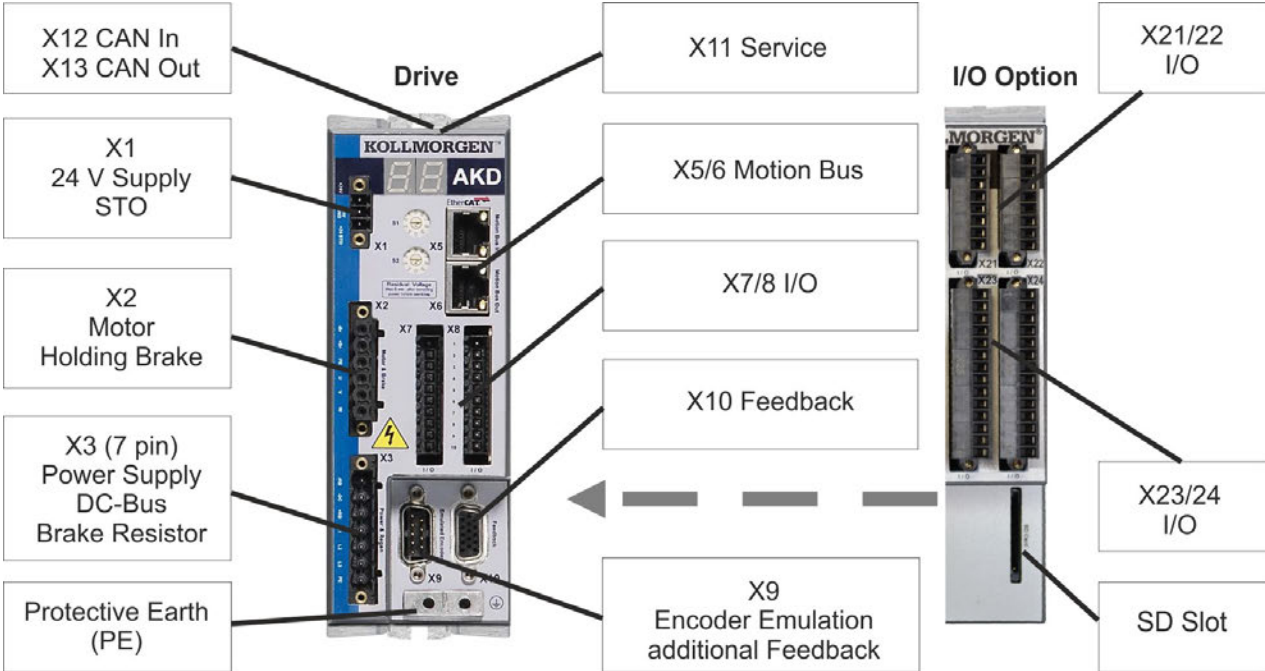

The I/O option is available for AKD-T drives only.

8.5.2 Connection diagram AKD-x00306, AKD-x00606

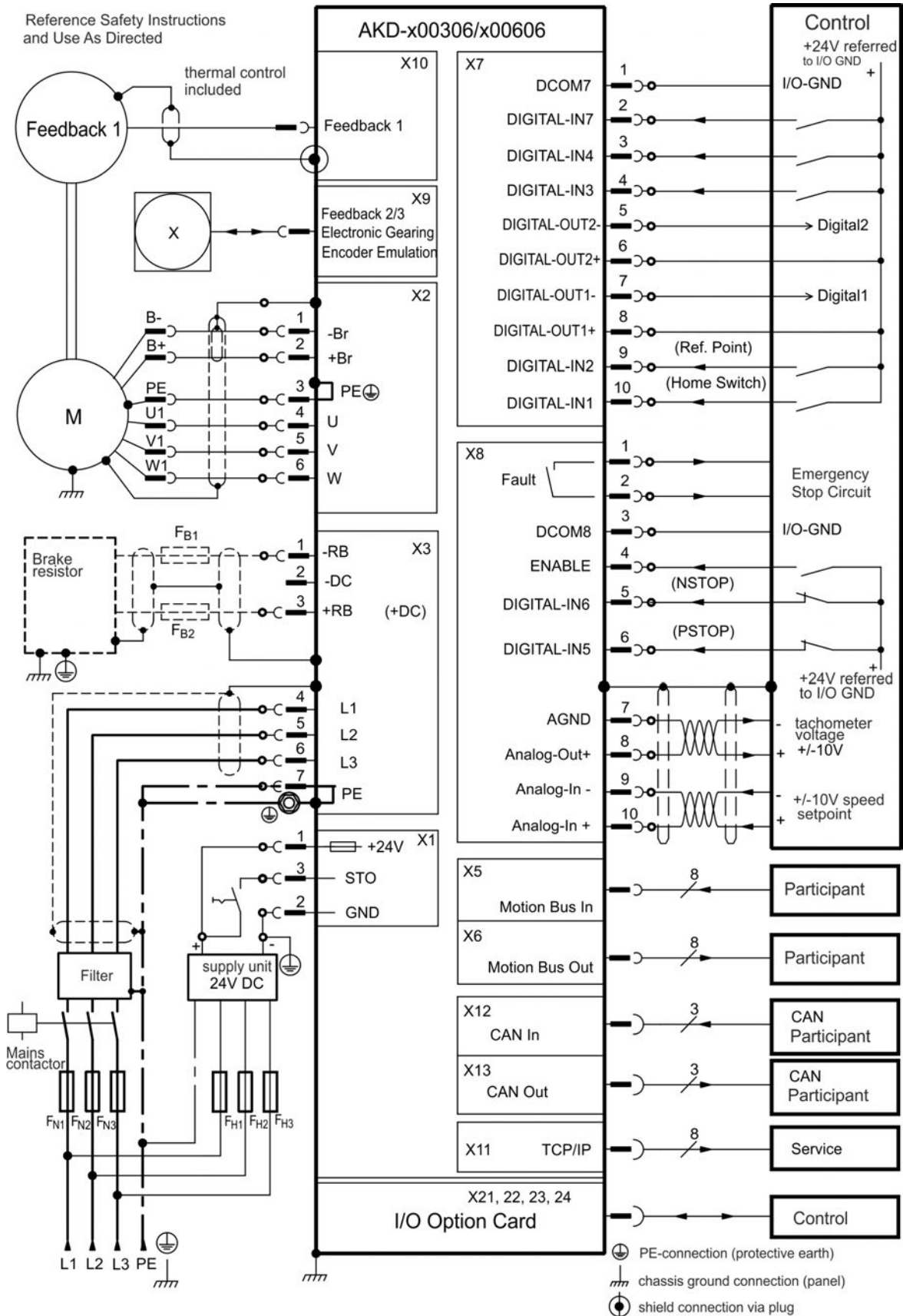

The I/O option is available for AKD-T drives only.

8.5.3 Connector assignment AKD-x01206

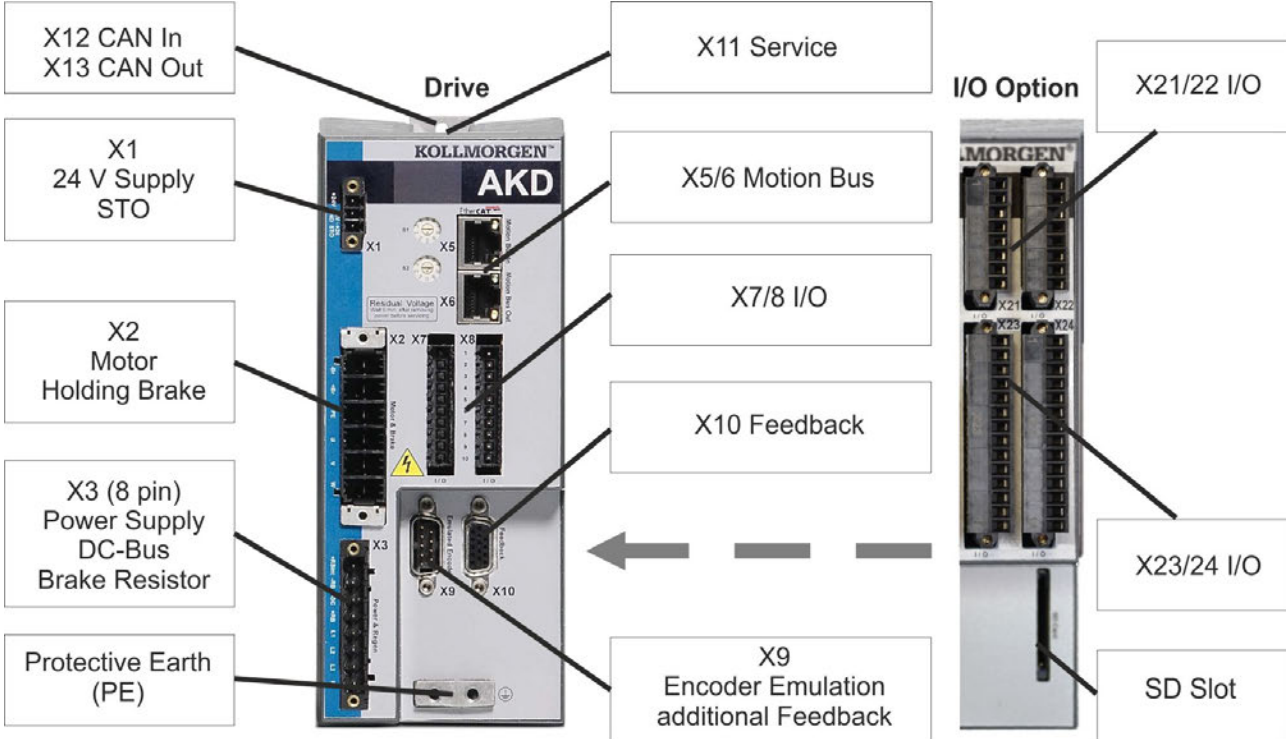

The I/O option is available for AKD-T drives only.

8.5.4 Connection diagram AKD-x01206

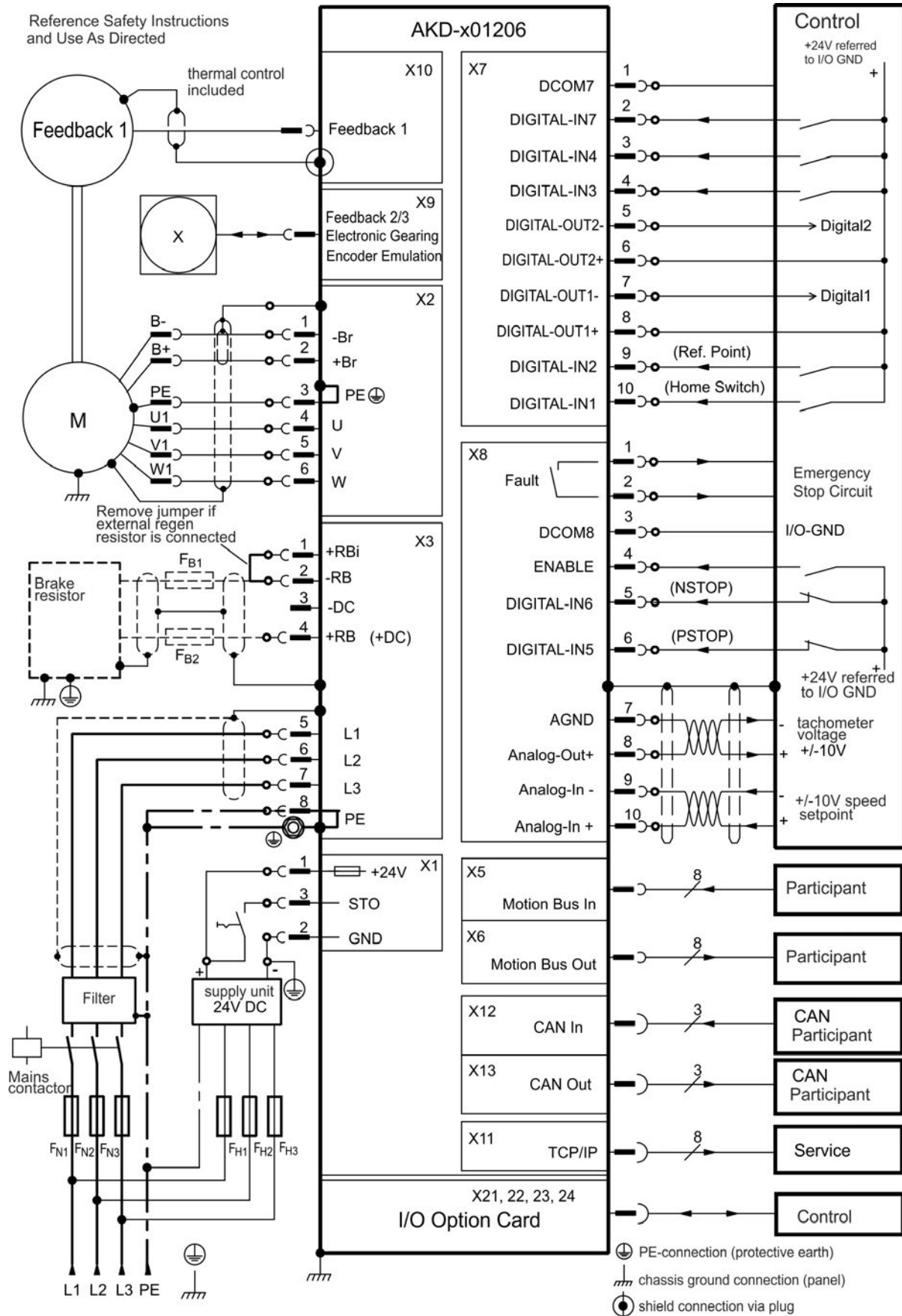

The I/O option is available for AKD-T drives only.

8.5.5 Connector assignment AKD-x02406 and AKD-x00307 to 02407

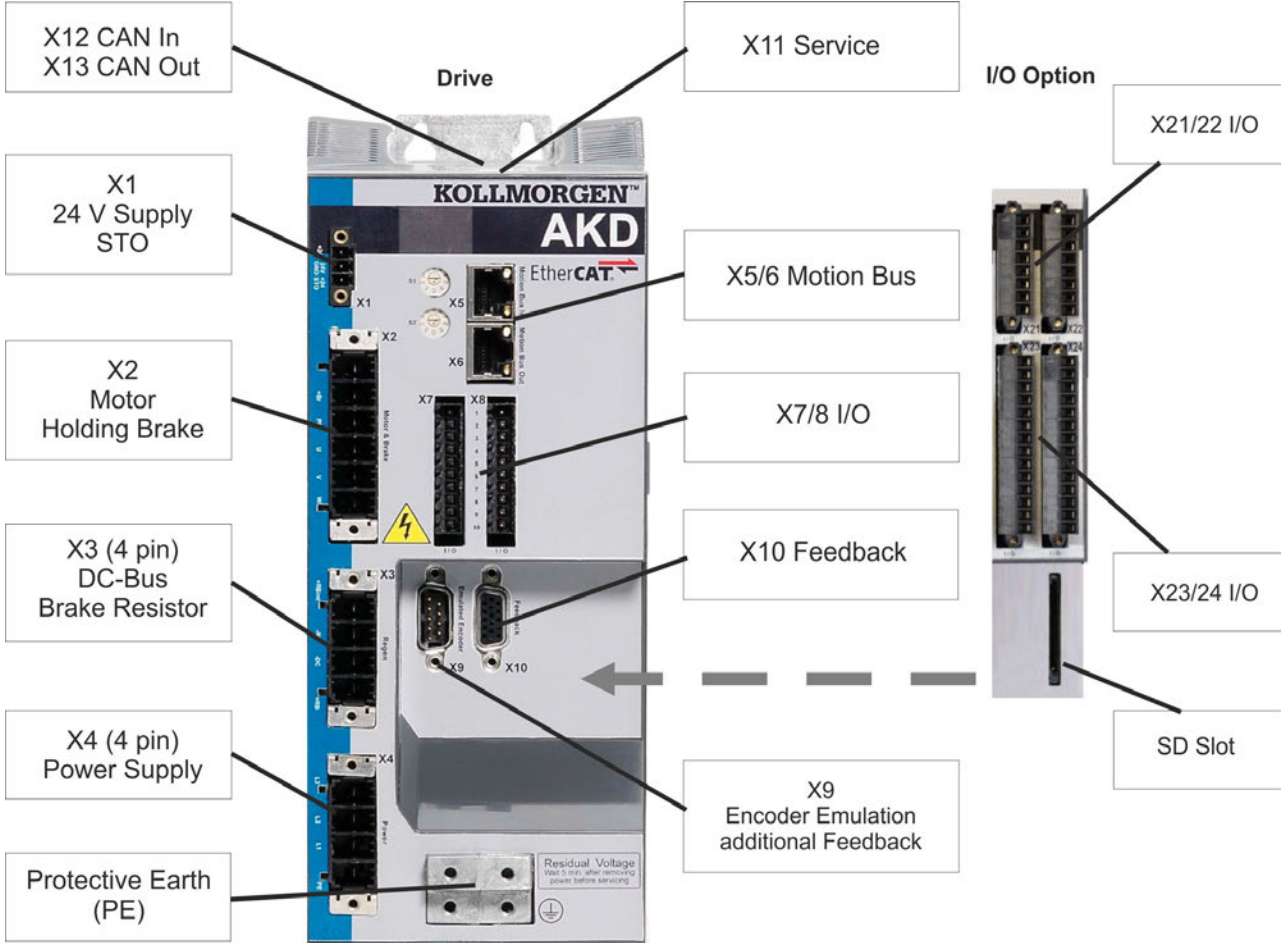

The I/O option is available for AKD-T drives only.

8.5.6 Connection diagram AKD-x02406 and AKD-x00307 to 02407

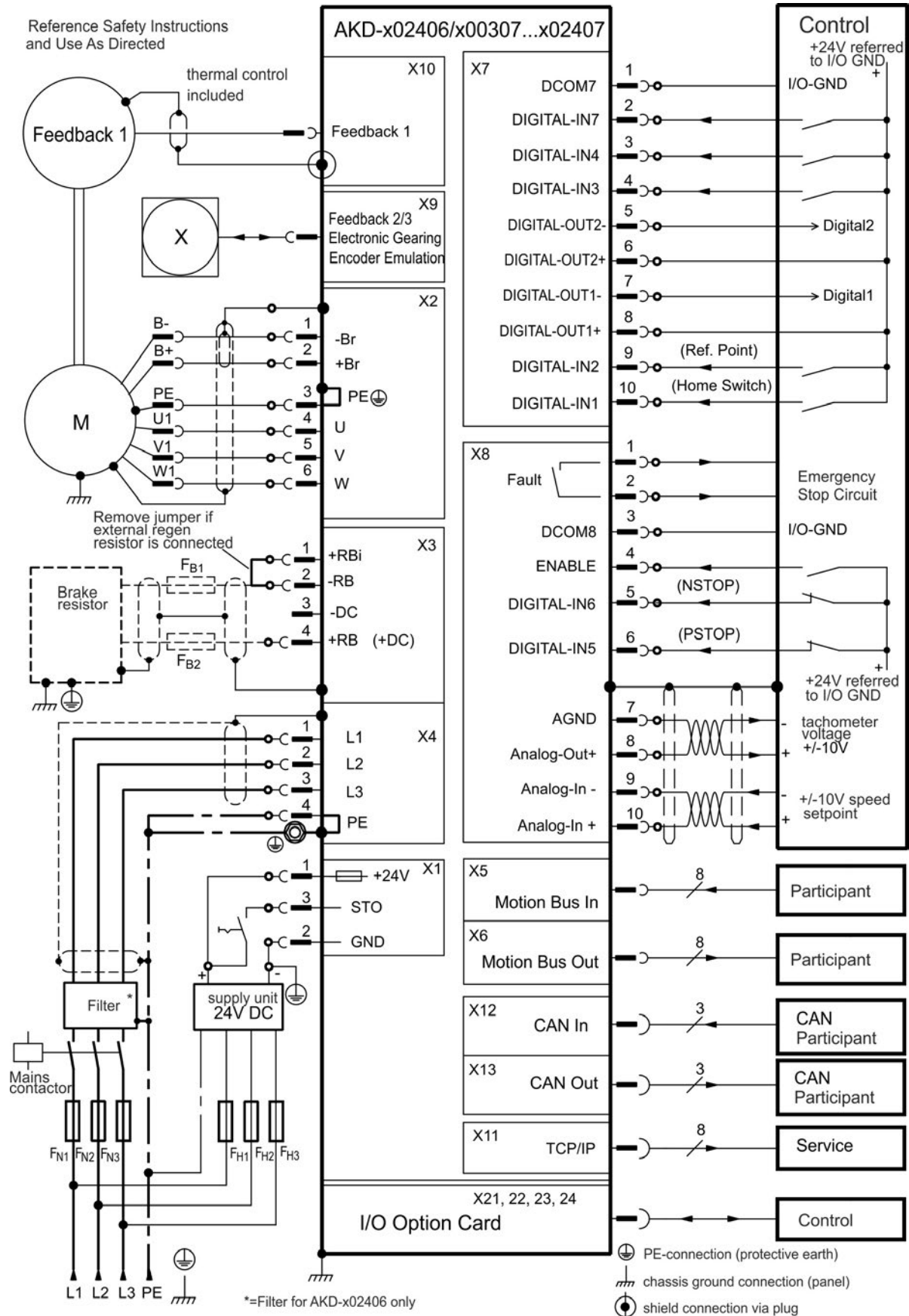

The I/O option is available for AKD-T drives only.

8.5.7 Connector assignment AKD-x04807

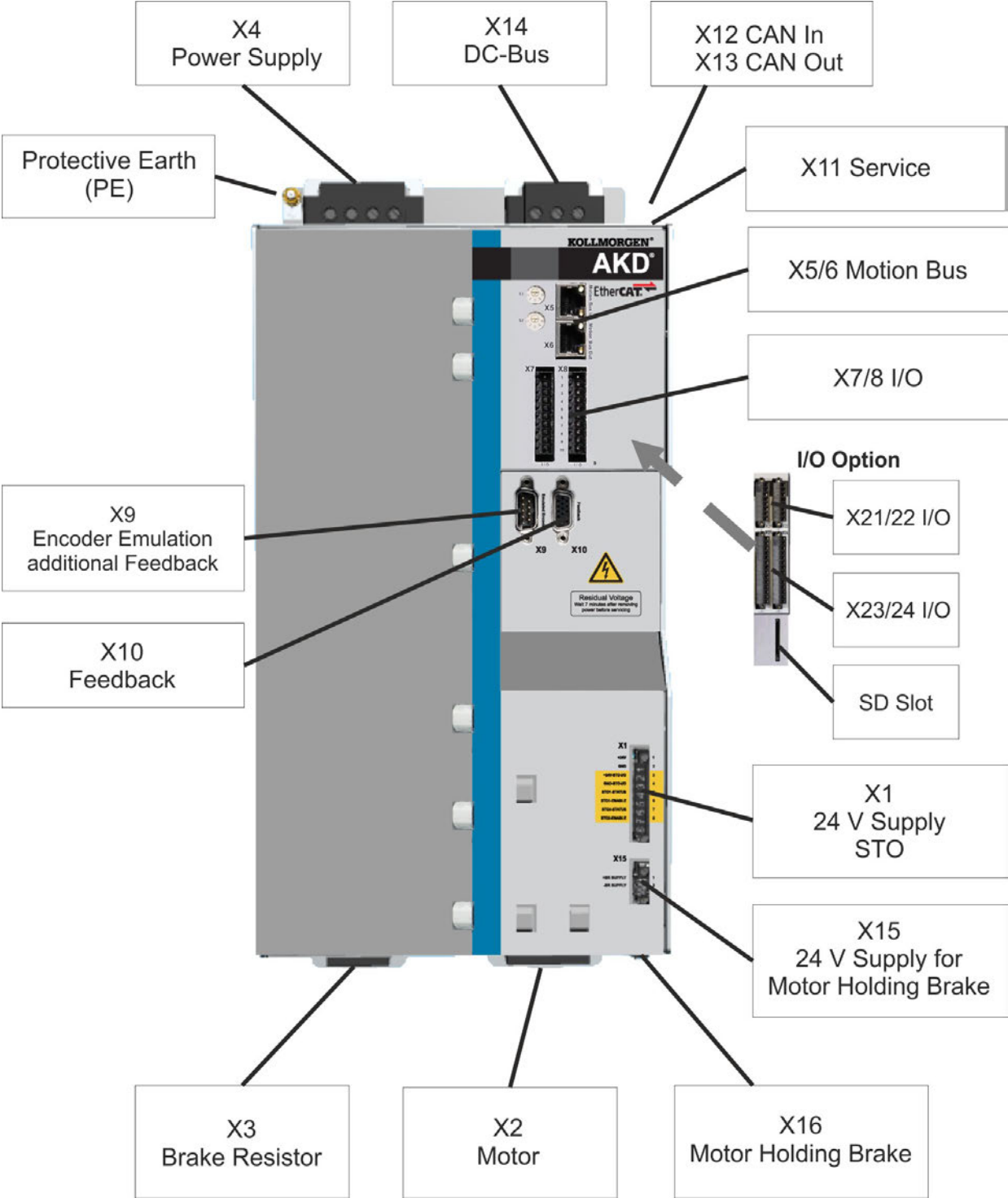

8.5.8 Connection diagram AKD-x04807

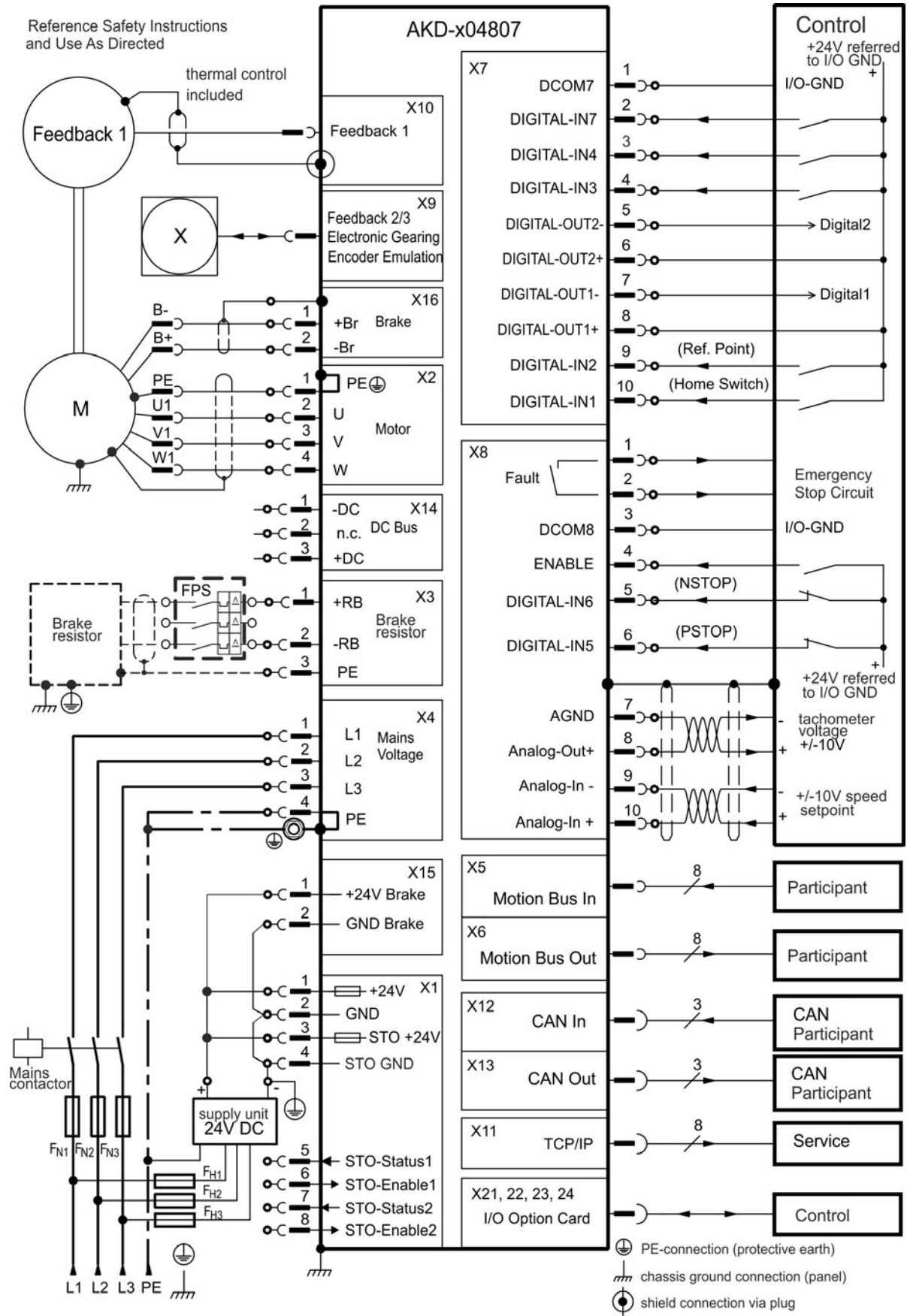

8.6 Connection Overview AKD-M

8.6.1 Connector assignment AKD-M00306, AKD-M00606

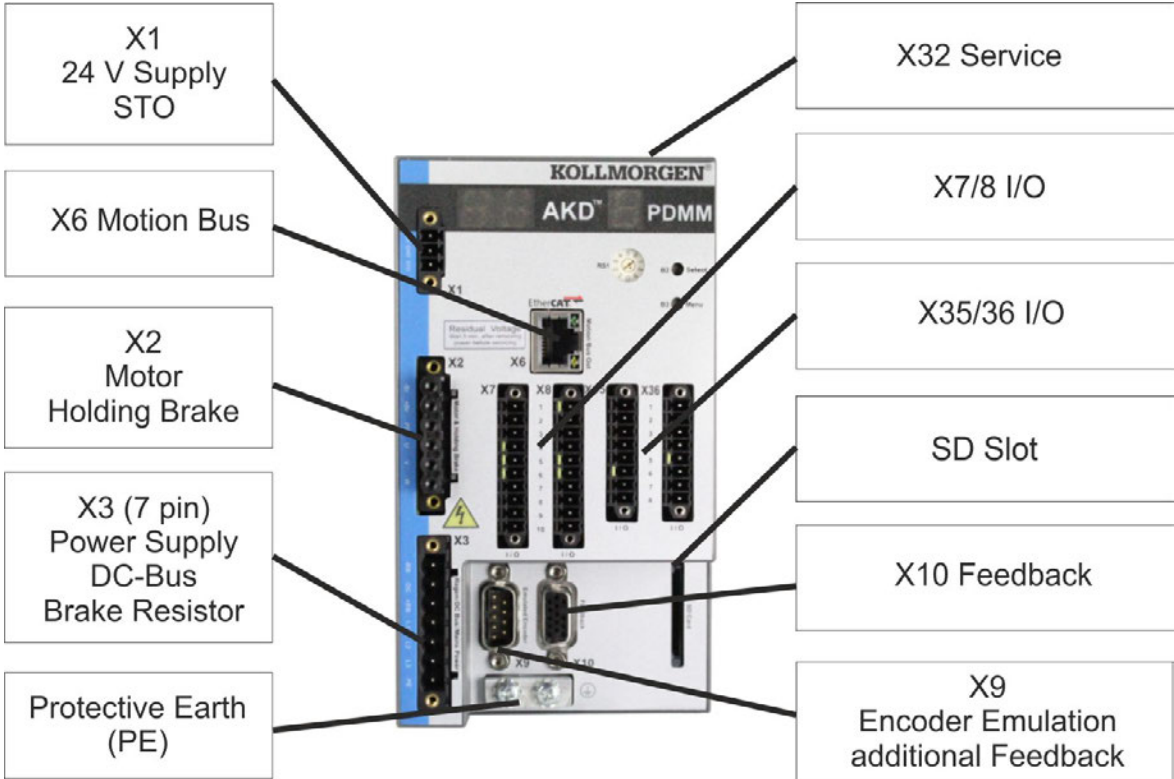

8.6.2 Connection diagram AKD-M00306, AKD-M00606

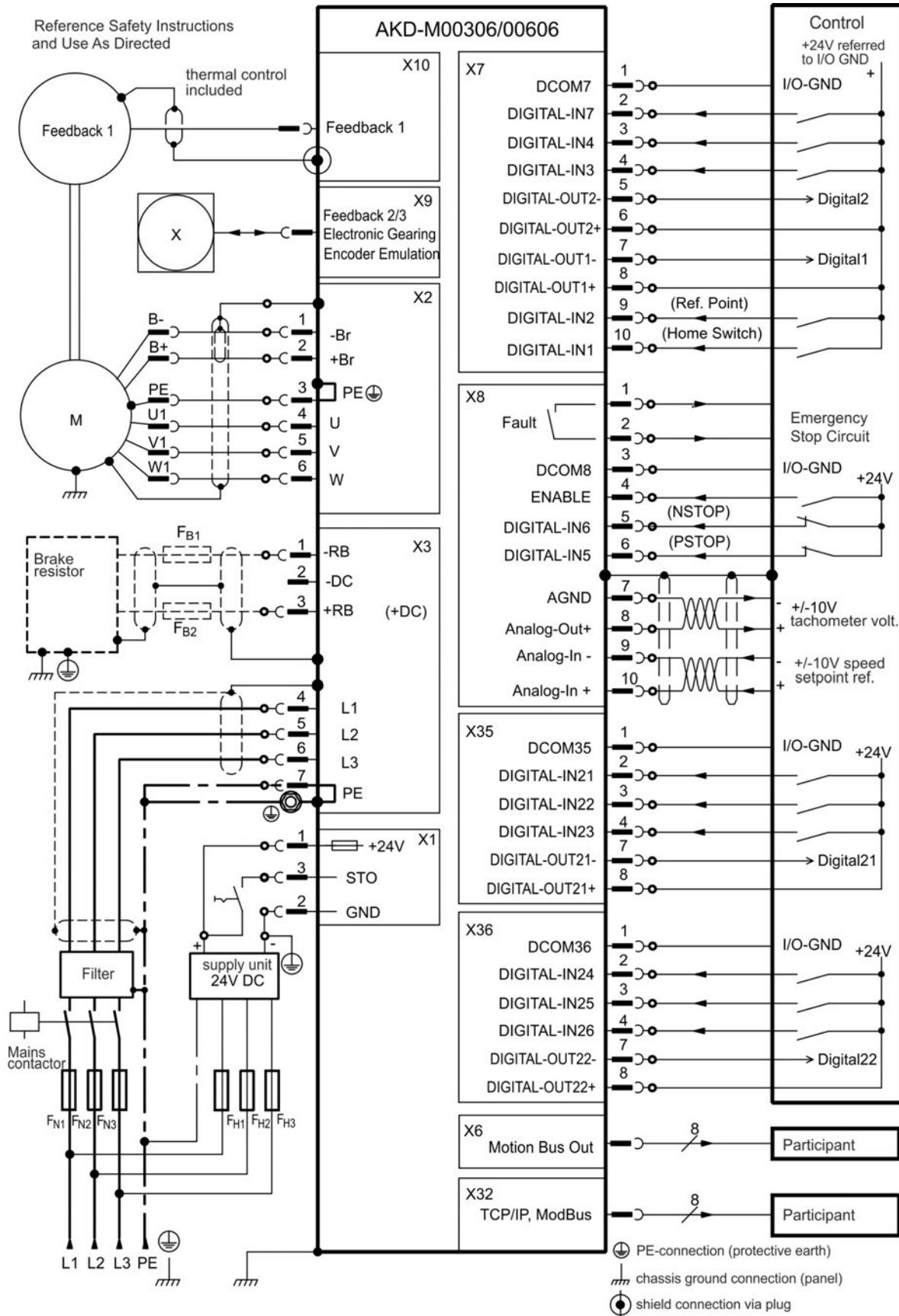

8.6.3 Connector assignment AKD-M01206

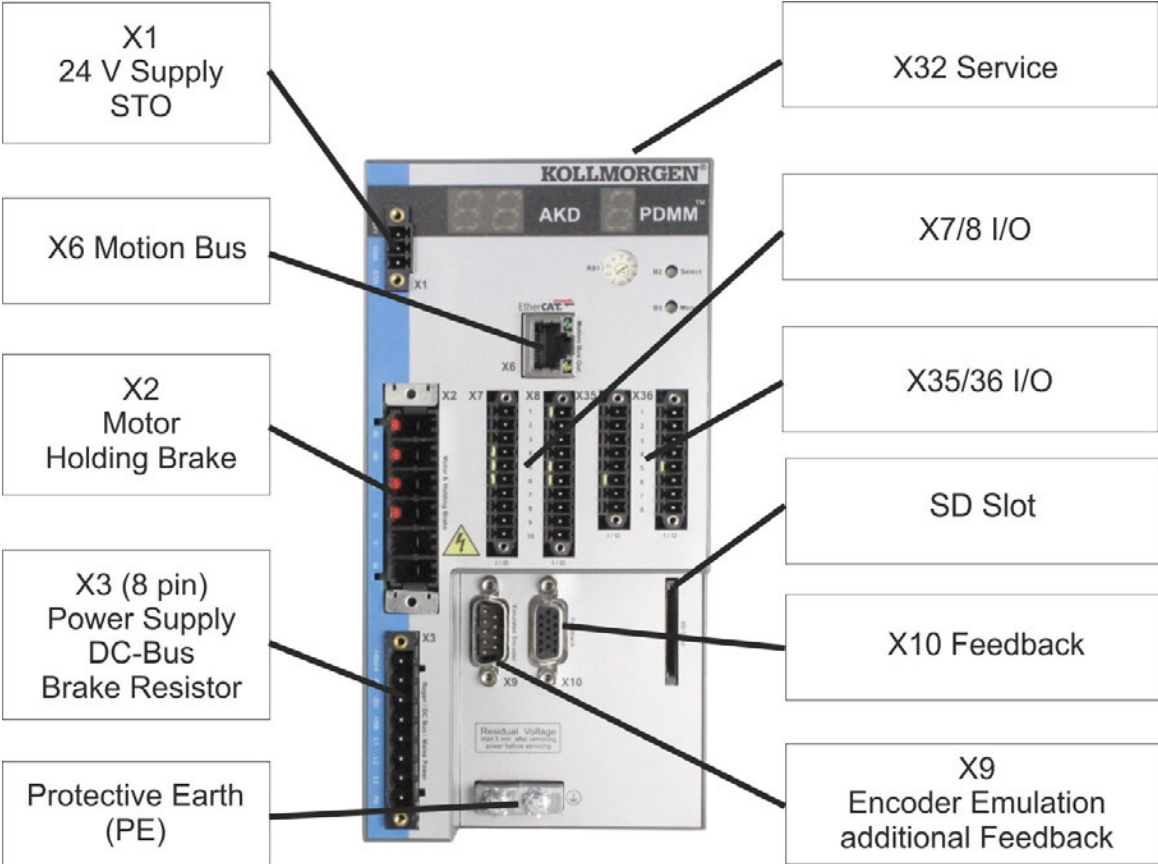

8.6.4 Connection diagram AKD-M01206

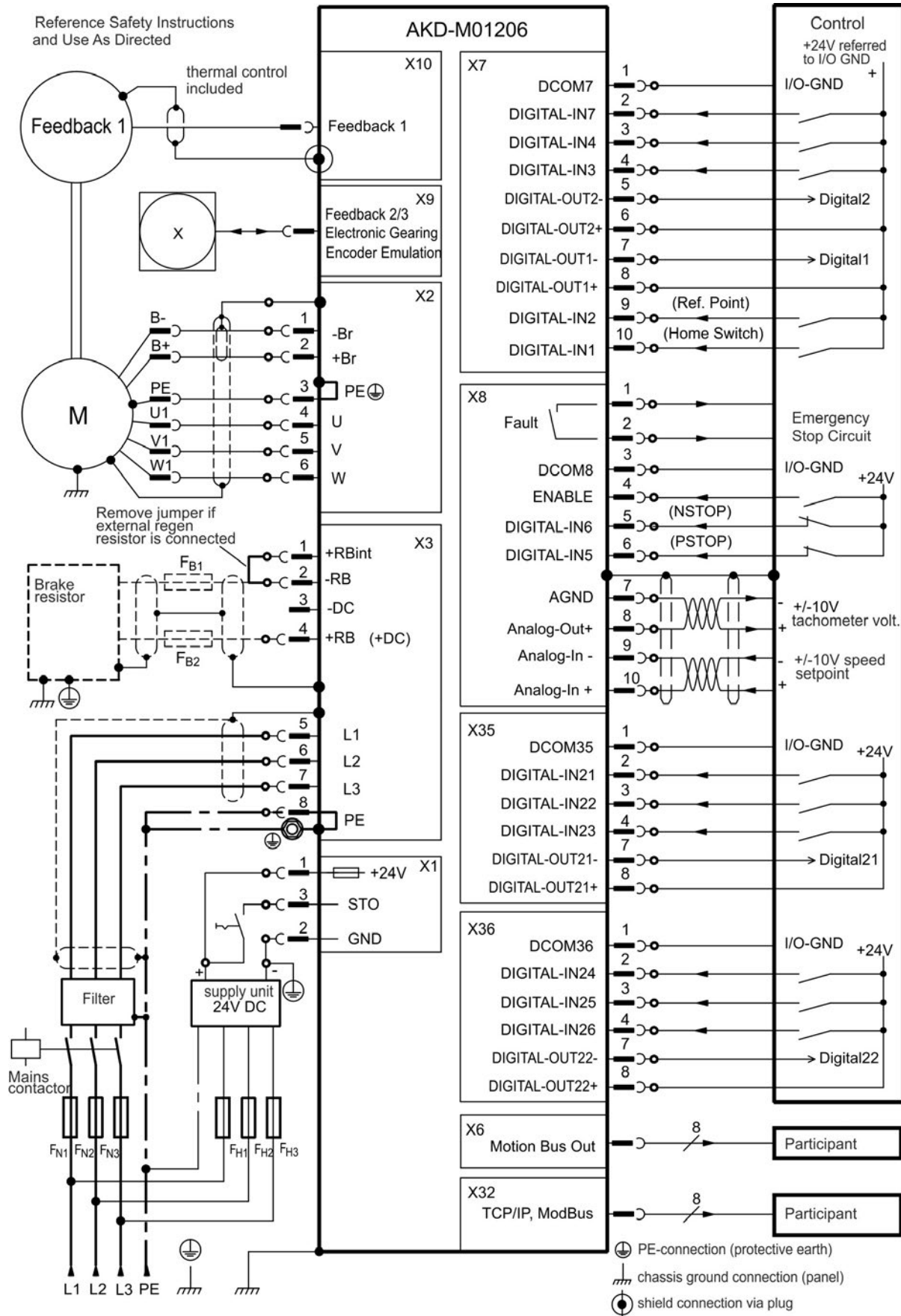

8.6.5 Connector assignment AKD-M02406, AKD-M00307 to AKD-M02407

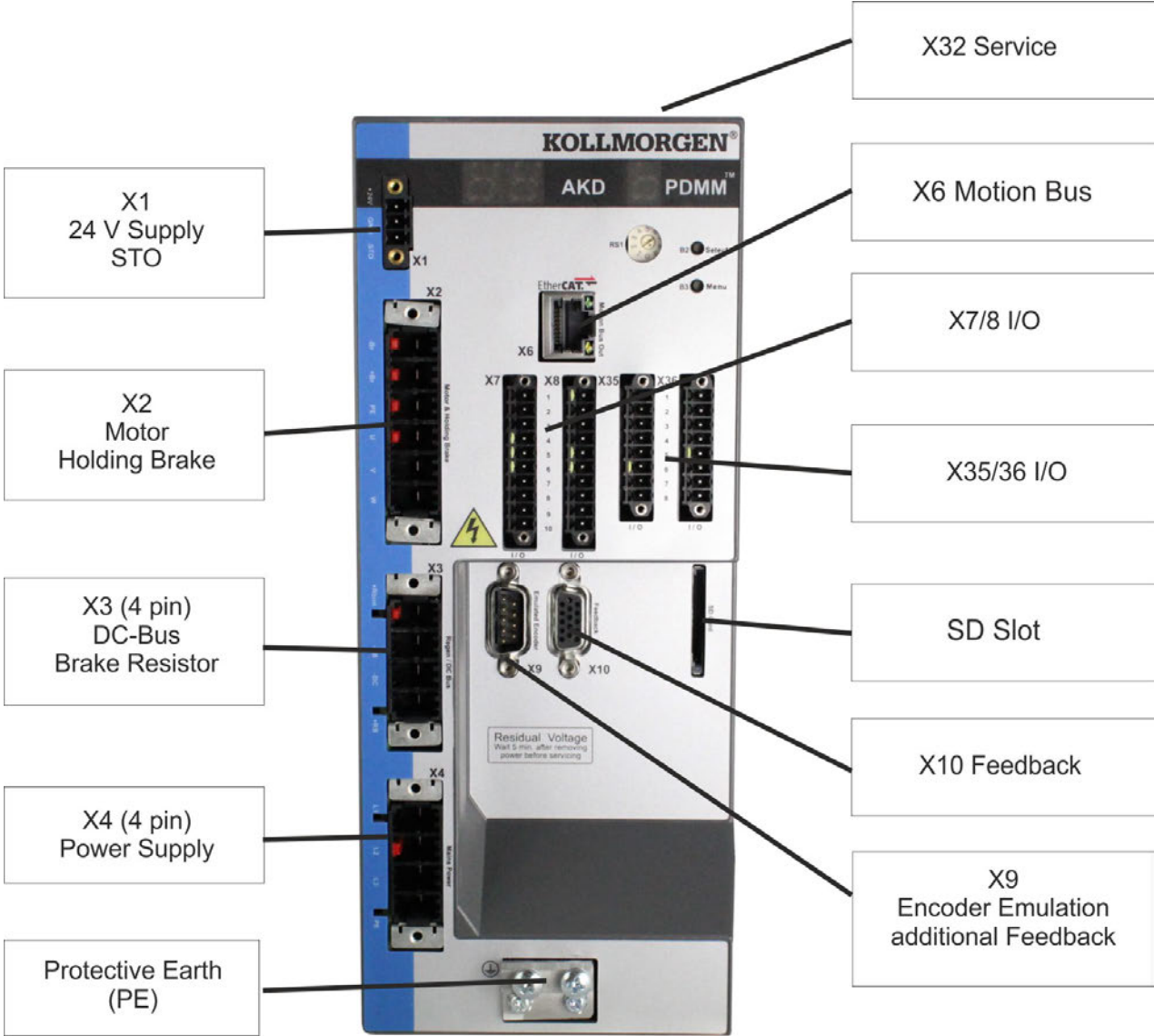

8.6.6 Connection diagram AKD-M02406, AKD-M00307 to AKD-M02407

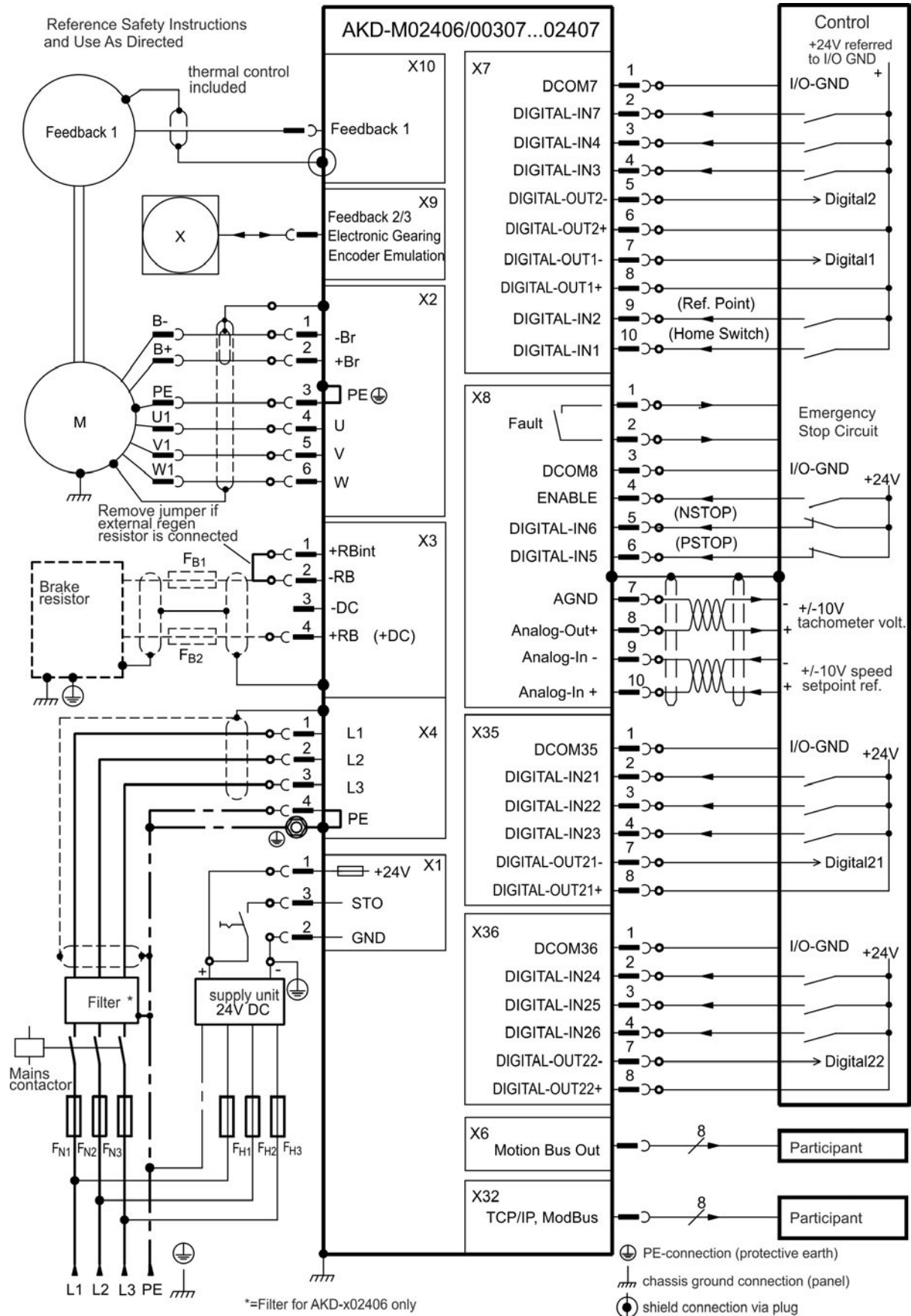

8.6.7 Connector assignment AKD-M04807

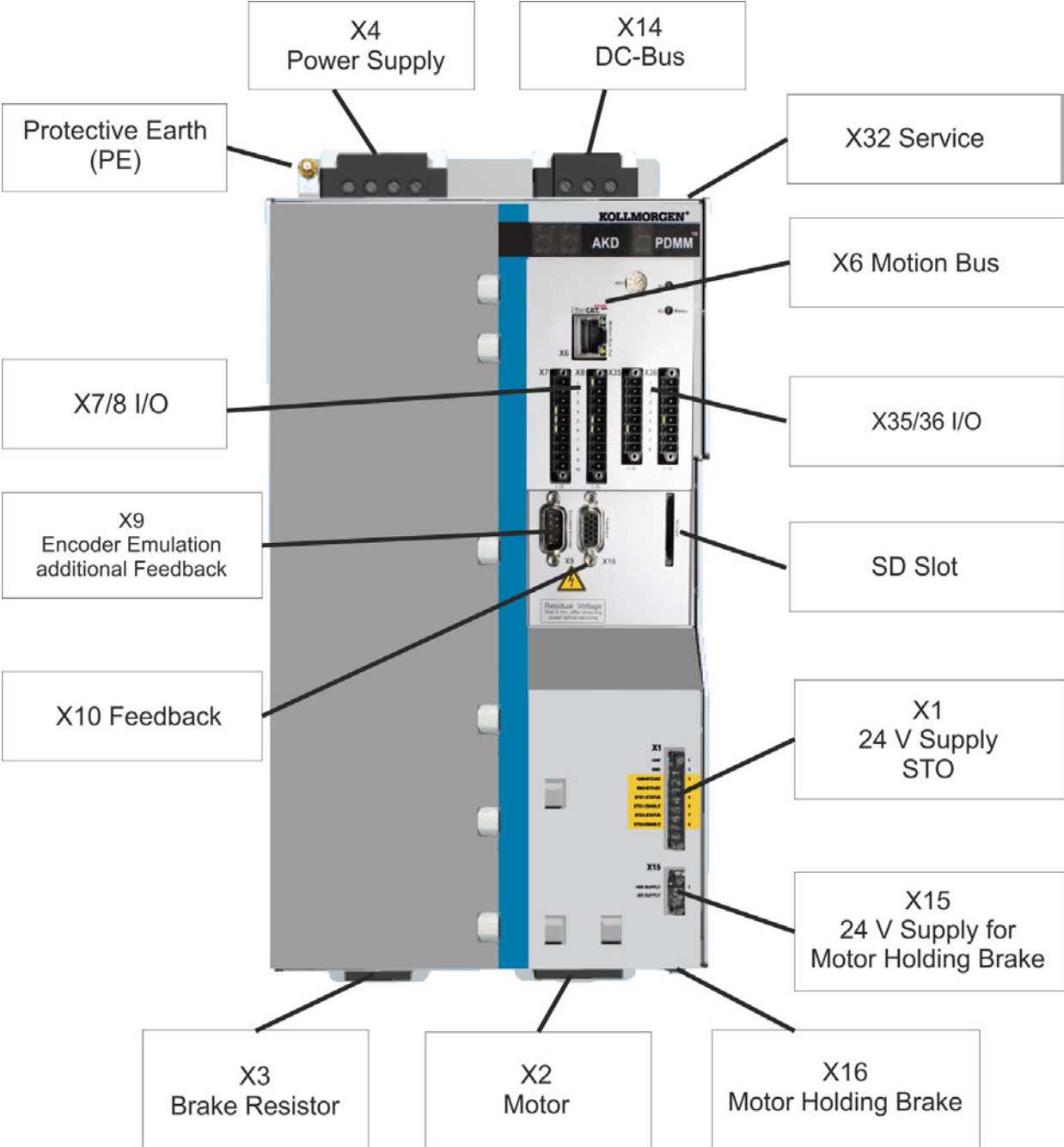

8.6.8 Connection diagram AKD-M04807

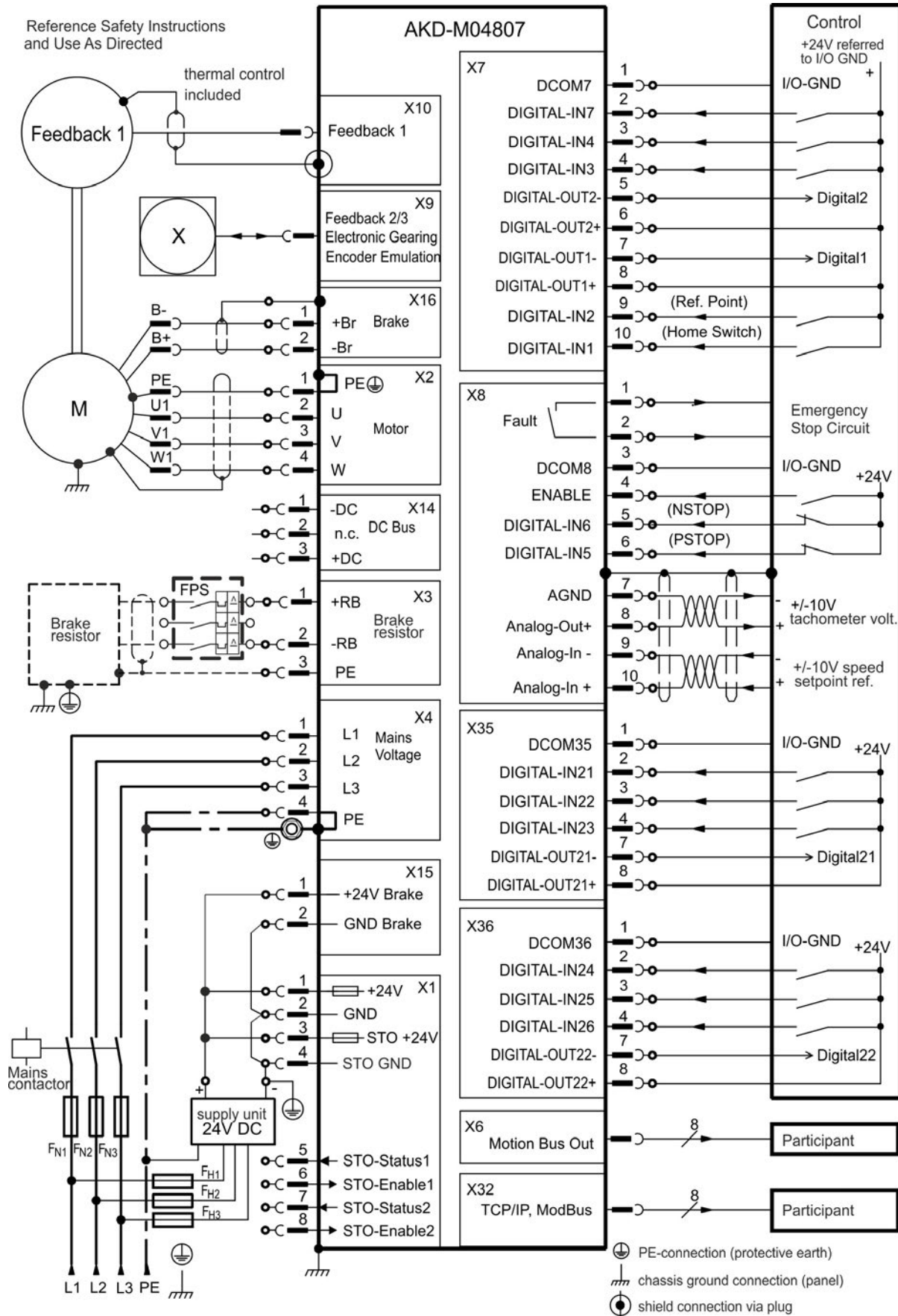

8.7 EMI Noise Reduction

8.7.1 Recommendations for EMI noise reduction

The following guidelines will help you to reduce problems with electrical noise in your application.

- **Ensure good connections between the cabinet components.**
Connect the back panel and cabinet door to the cabinet body using several conductive braids. Never rely on hinges or mounting bolts for ground connections. Provide an electrical connection across the entire back surface of the drive panel. Electrically-conductive panels such as aluminum or galvanized steel are preferred. For painted and other coated metal panels, remove all coating behind the drive.
- **Ensure good ground connection.**
Connect from cabinet to proper earth ground. Ground leads should be the same gauge as the leads to main power or one gauge smaller.
- **Use Kollmorgen cables.**
Route power and control cables separately, Kollmorgen recommends a distance of at least 200 mm to improve interference immunity.
If a motor power cable is used that includes cores for brake control, the brake control cores must be separately shielded.
- **Ground the shielding at both ends.**
Ground all shielding with large areas (low impedance), with metalized connector housings or shield connection clamps wherever possible. For cables entering a cabinet, connect shields on all 360° of the cable. Never connect a simple "pigtail." For more information on shielding concepts, (→ # 98).
- **With separate mains filter, maintain separation of leads entering and exiting the mains filter (line power filter).**
Locate the filter as close as possible to the point where the incoming power enters the cabinet. If it is necessary for input power and motor leads to cross, cross them at 90°.
- **Feedback lines may not be extended, since the shielding would be interrupted and the signal processing may be disturbed.**
Install all feedback cables with an adequate cross-section, per IEC 60204 (→ # 40) and use the requested cable material to reach maximum cable length.
- **Splice cables properly.**
If you need to divide cables, use connectors with metal backshells. Ensure that both shells connect along the full 360° of the shields. No portion of the cabling should be unshielded. Never divide a cable across a terminal stripe
- **Use differential inputs for analog signals.**
Noise susceptibility in analog signals is greatly reduced by using differential inputs. Use twisted-pair, shielded signal lines, connecting shields on both ends.
- **Cables between drives and filters or external regen resistors must be shielded.**
Install all power cables with an adequate cross-section, per IEC 60204 (→ # 40) and use the requested cable material to reach maximum cable length.

8.7.2 Shielding with external shielding busbar

EMC filtering must be done externally by the user if necessary, which requires the use of shielded cables. Kollmorgen recommends a star point shield connection, for example, with a shielding busbar.

8.7.2.1 Shielding Concept

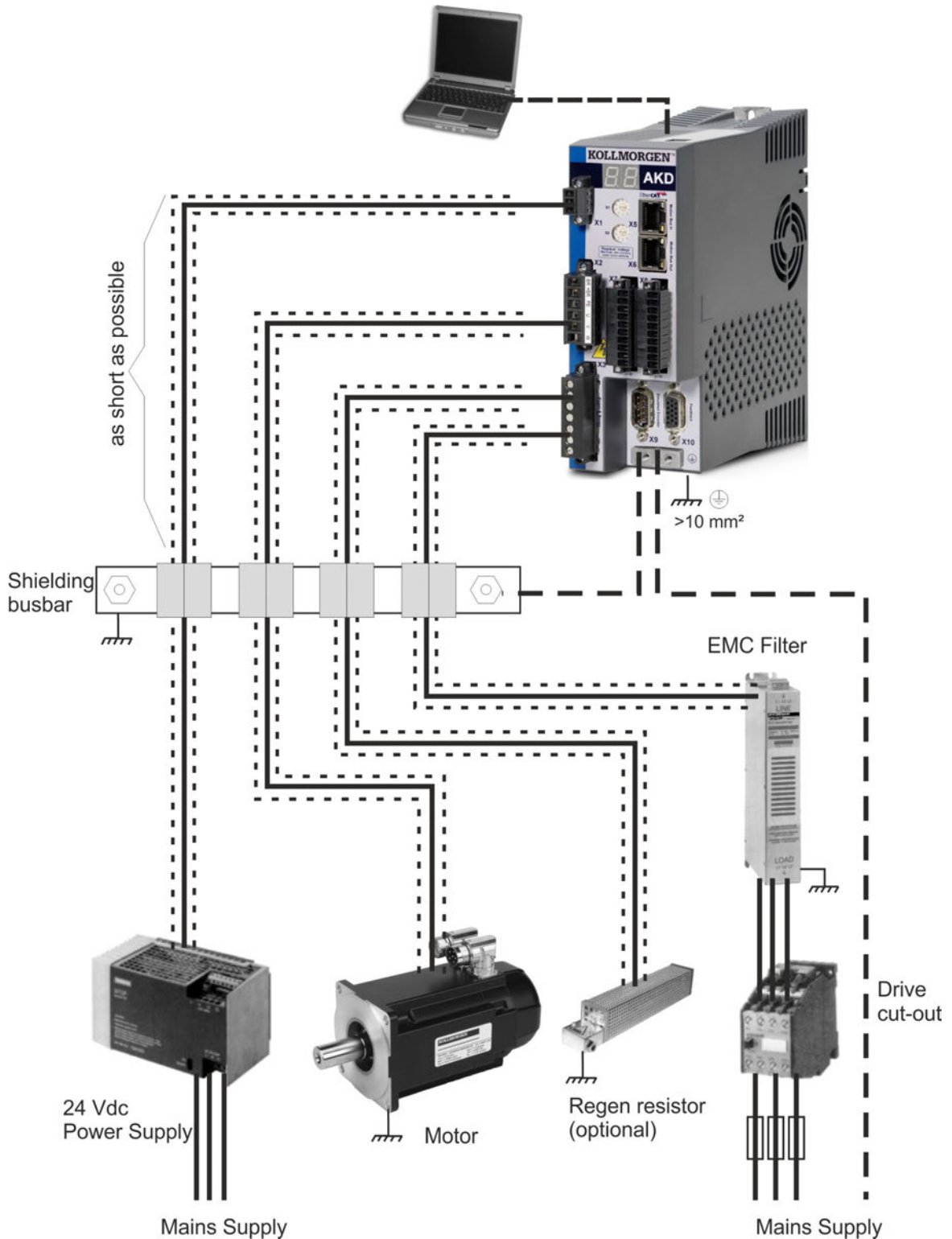

8.7.2.2 Shielding Busbar



The power cable shields (line in, motor cable, external regen resistor) can be routed to an additional busbar via shield clamps.

Kollmorgen recommends using Weidmüller KLBÜ shield clamps.

A possible scenario for setting up a busbar for the above shield clamps is described below.

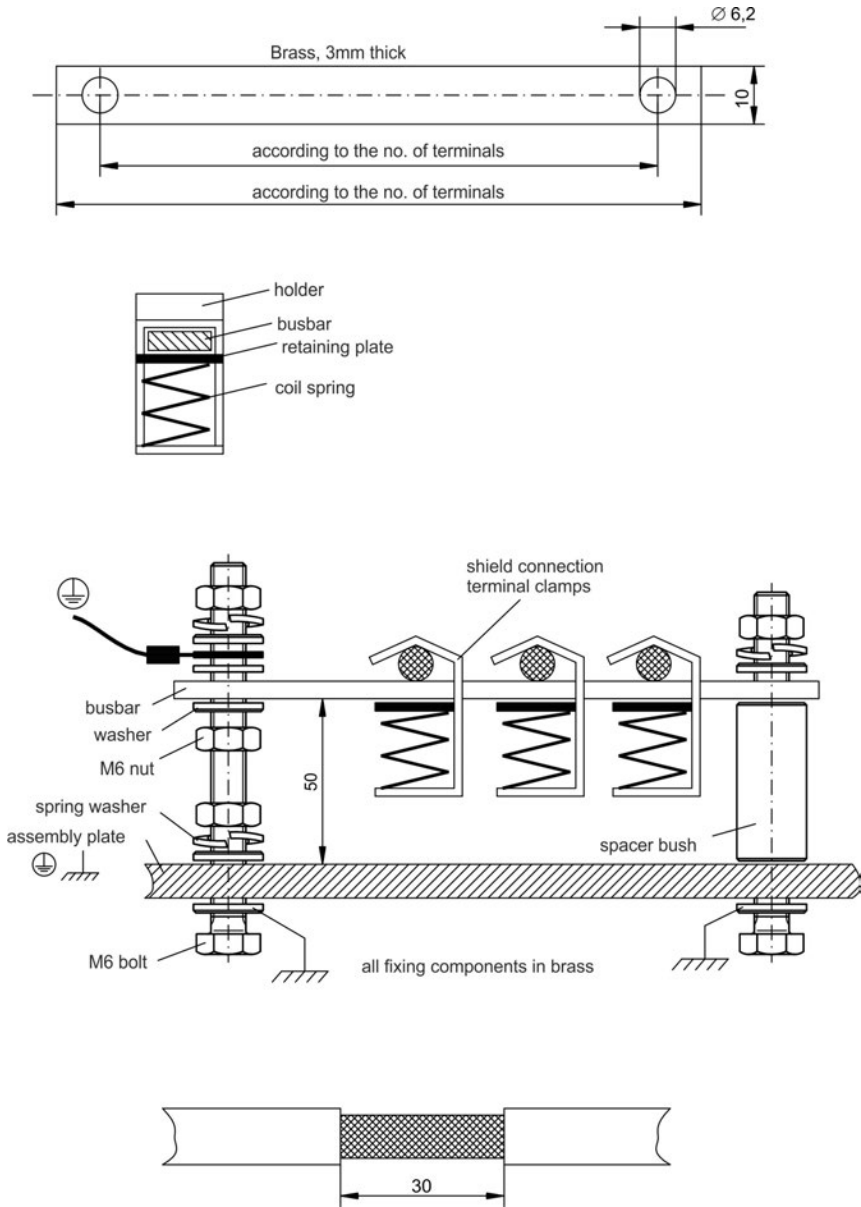

1. Cut a busbar of the required length from a brass rail (cross-section 10 x 3 mm) and drill holes in it as indicated. All shield clamps required must fit between the drill holes.

CAUTION
Risk of injury due to the spring force of the coil spring. Use pliers.

2. Squeeze together the coil spring and the supporting plate and push the busbar through the opening in the holder.
3. Mount the busbar with the shield clamps fitted on the assembly plate. Use either metal spacer bushes or screws with nuts and accessories to maintain a spacing of 50 mm. Earth the busbar using a single conductor with a cross-section of at least 2.5 mm².

4. Strip the external cable sheath to a length of approx. 30 mm, taking care not to damage the braided shield. Push the shield clamp up and route the cable to it via the busbar.

NOTICE
Make sure there is good contact between the shield clamp and the braided shield.

8.7.3 Shielding connection to the drive

You can connect cable shielding directly to the drive by using grounding plates, shield connection clamps, and a motor connector with strain relief and grounding plate.

8.7.3.1 Grounding plates

Mount the grounding plates to the drive as shown in the photos below.

AKD-x0306 to x1206 types:
L-shape grounding plate (EU only)

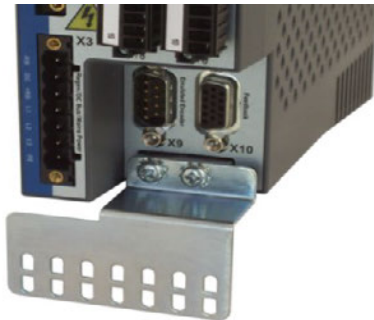

AKD-x02406 & xzzz07 types:
flat grounding plate



8.7.3.2 Shield connection clamps



Use shield connection clamps (see accessories manual). These hook into the grounding plate and ensure optimum contact between the shield and the grounding plate.

Kollmorgen recommends using Phoenix Contact SK14 shield clamps with clamp range of 6-13mm.

8.7.3.3 Motor connector X2 with shielding connection

Alternative connection for the motor power connection by mating connector with strain relief.

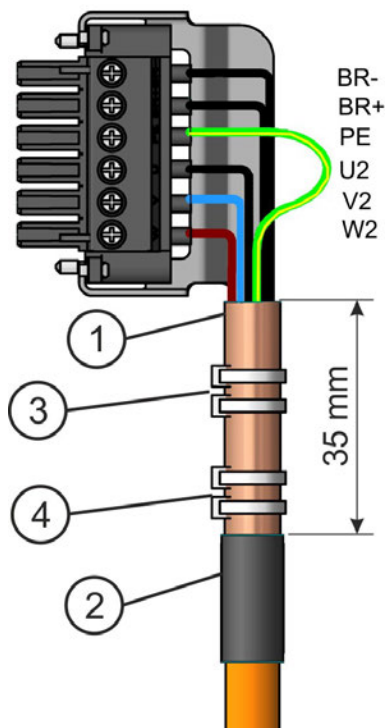

Strip the external cable sheath to a length of approx. 120 mm, taking care not to damage the braided shield. Push the braided shield (1) back over the cable and secure with a rubber sleeve (2) or shrink sleeve.

Shorten all the wires apart from the protective earth (PE) wire (green/yellow) by about 20 mm so that the PE wire is now the longest wire. Strip all wires and fit wire end ferrules.

Secure the braided shield of the cable to the shroud with a cable tie (3) and use a second tie (4) to fasten the cable.

Wire the connector as shown in the connection diagram. Plug in the connector to the socket on the front of the AKD.

Screw the connector in place. This ensures that there is conductive contact over a large surface area between the braided shield and the front panel.

8.8 Electrical Supply Connection

8.8.1 Connection to various mains supply networks AKD-xzzz06 (120V to 240V)

 **WARNING**
There is a danger of electrical shock with serious personnel injury if the drive is not properly grounded. An isolating transformer is required for 400 to 480 V networks to get a maximum voltage of 240 V +10%.

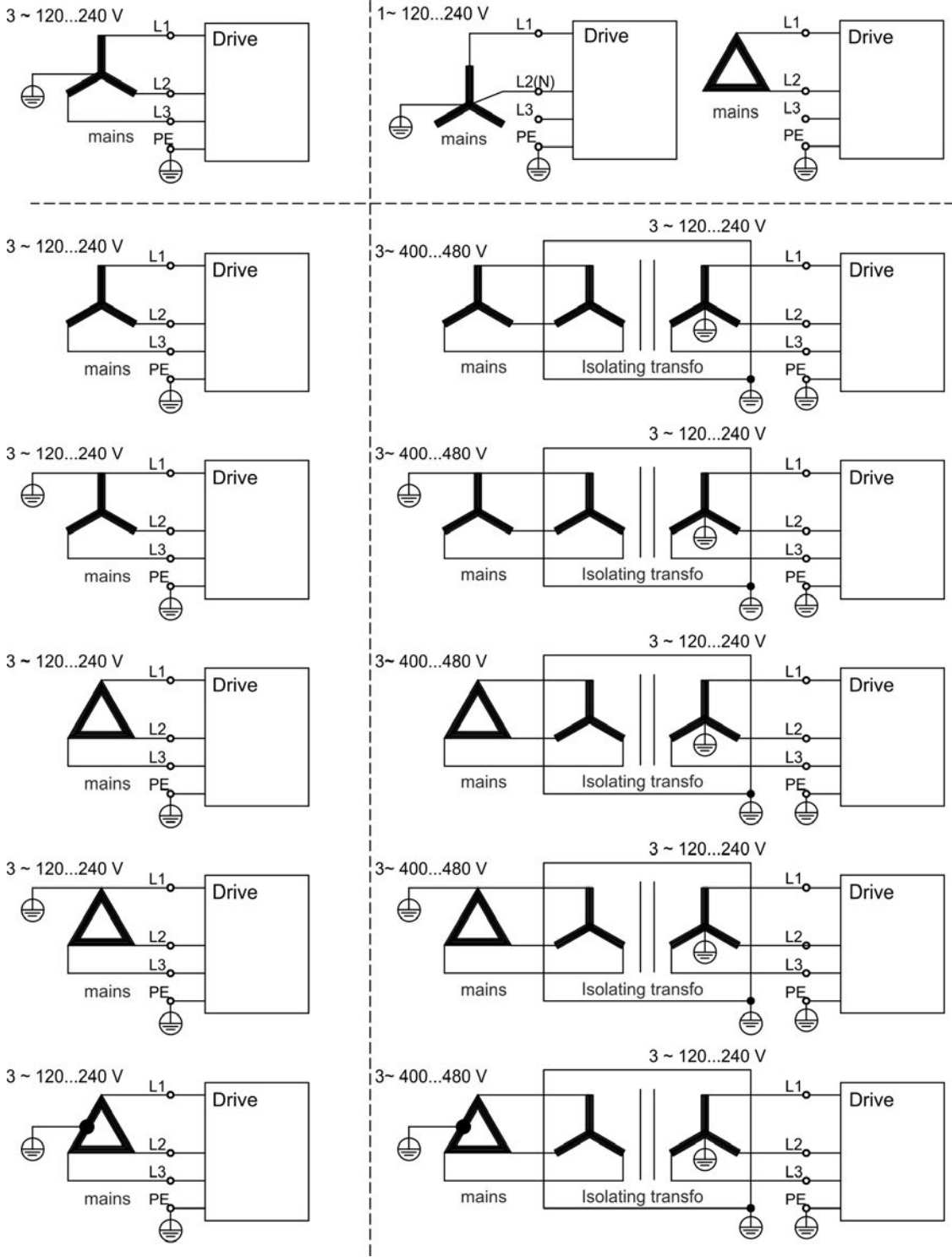

8.8.2 Connection to various mains supply networks AKD-xzzz07 (240V to 480V)



WARNING

There is a danger of electrical shock with serious personnel injury if the drive is not properly grounded. An isolating transformer is required for 120V networks to get a minimum voltage of 240 V +10%.

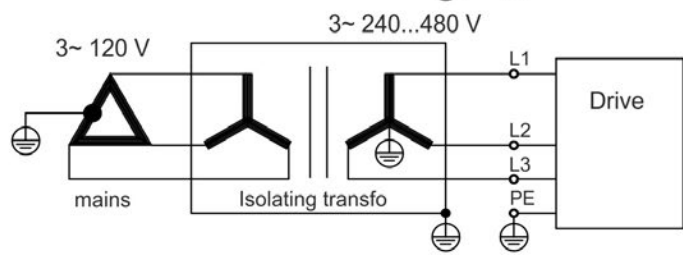
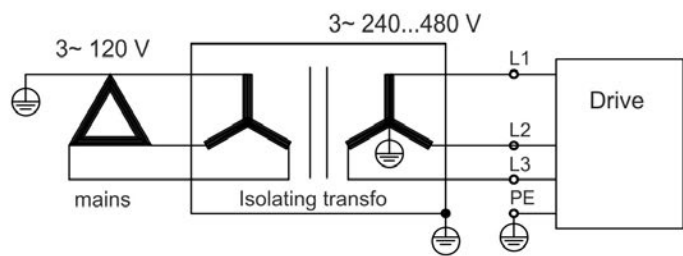
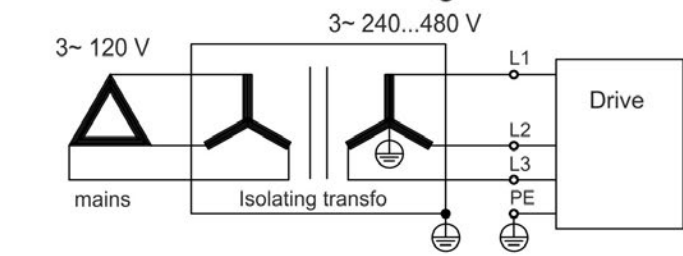
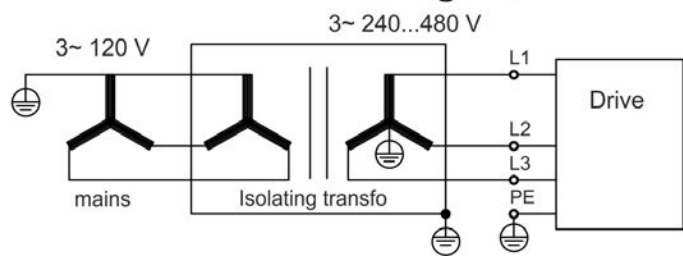
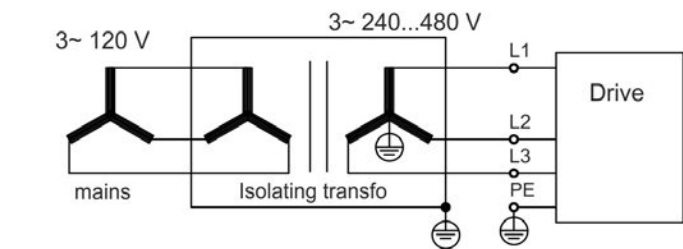
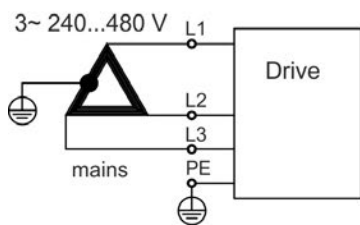
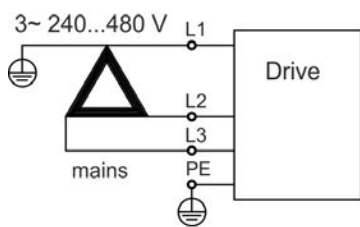
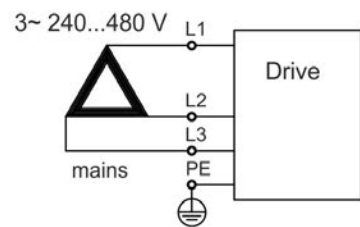
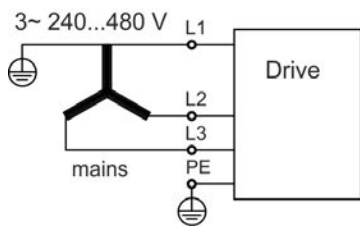
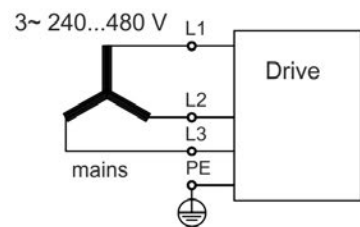
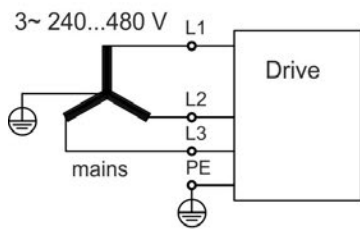

8.8.3 24 V auxiliary supply (X1)

The following diagram describes external 24 VDC power supply, electrically isolated, for example, via an isolating transformer. The required current rating depends on the use of motor brake and option card (→ # 35) or (→ # 36).

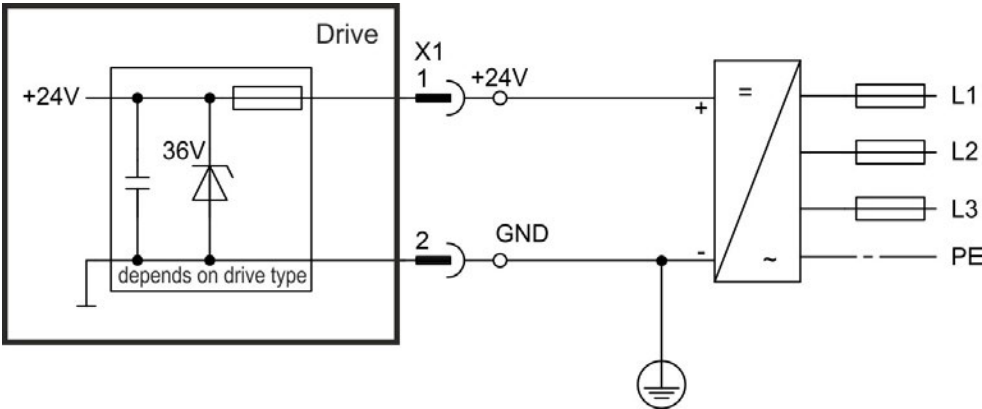

8.8.3.1 AKD-x003 to 024, connector X1



Pin	Signal	Description
1	+24	+24 VDC Auxiliary voltage
2	GND	24V Supply GND
3	STO	STO enable (Safe Torque Off)

8.8.3.2 AKD-x048, connector X1

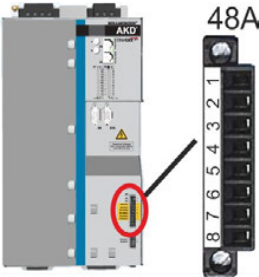

Pin	Signal	Description
1	+24 V	+24 VDC Auxiliary voltage
2	GND	24V Supply GND
3	STO +24V	STO+24 VDC Auxiliary voltage
4	STO GND	STO Supply GND
5	STO-Status 1	Safe Torque Off status channel 1
6	STO-Enable 1	Safe Torque Off enable channel 1
7	STO-Status 2	Safe Torque Off status channel 2
8	STO-Enable 2	Safe Torque Off enable channel 2

8.8.4 Mains supply connection (X3, X4)

Drives in the AKD series can be supplied as follows:

- AKD-xzzz06: 1 or 3 phase industrial supply networks (not more than 200 kA symmetrical rated current at 120 V and 240 V).
- AKD-xzzz07: 3 phase industrial supply networks (not more than 200 kA symmetrical rated current at 240 V, 400 V and 480 V).
- AKD-x04807: In case of mains voltage asymmetry >3% a mains choke 3L0,24-50-2 (see regional Accessories Manual) must be used.

Connection to other voltage types of supply networks is possible with an additional isolating transformer (→ # 101). Periodic overvoltages between phases (L1, L2, L3) and the housing of the drive must not exceed 1000 V peak. In accordance with IEC 61800, voltage spikes (< 50 μs) between phases must not exceed 1000 V. Voltage spikes (< 50 μs) between a phase and the housing must not exceed 2000 V.

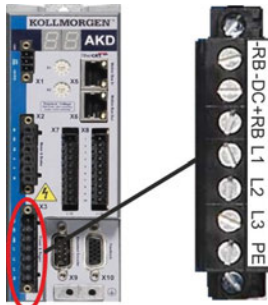

AKD-x00306 to AKD-x00606 (X3)		
Pin	Signal	Description
4	L1	Line 1
5	L2	Line 2
6	L3	Line 3
7	PE	Protective Earth

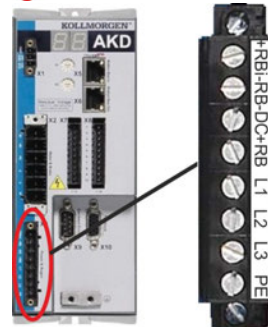

AKD-x01206 (X3)		
Pin	Signal	Description
5	L1	Line 1
6	L2	Line 2
7	L3	Line 3
8	PE	Protective Earth

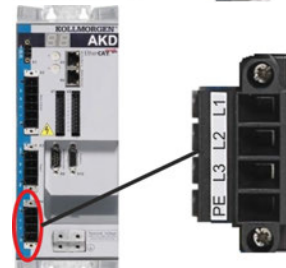

AKD-x02406 & AKD-x00307 to AKD-x02407 (X4)		
Pin	Signal	Description
1	L1	Line 3
2	L2	Line 2
3	L3	Line 1
4	PE	Protective Earth

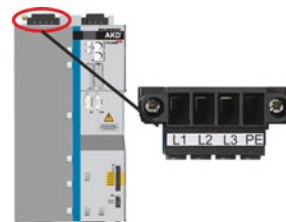

AKD-x04807 (X4)		
Pin	Signal	Description
1	L1	Line 1
2	L2	Line 2
3	L3	Line 3
4	PE	Protective Earth

8.8.4.1 Three phase connection (all AKD types)

- Directly to 3-phase supply network, supply networks (→ # 101)
- Filtering for AKD-xzzz06 to be provided by the user.
- Fusing (such as fusible cut-outs) to be provided by the user (→ # 38).

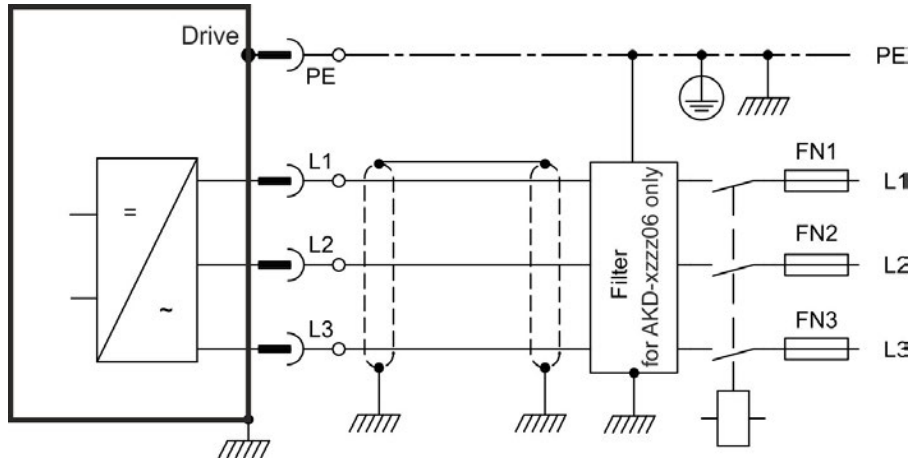

8.8.4.2 Single/Dual phase connection (AKD-x00306 to AKD-x01206 only)

- Directly to single-phase supply network (120 V_{-10%} to 240 V^{+10%}) with neutral line or Directly to two-phase supply network ((→ # 101)
- Supply networks(→ # 101)
- Leave L3 open circuit
- Filtering to be provided by the user.
- Fusing (such as fusible cut-outs) to be provided by the user (→ # 38)

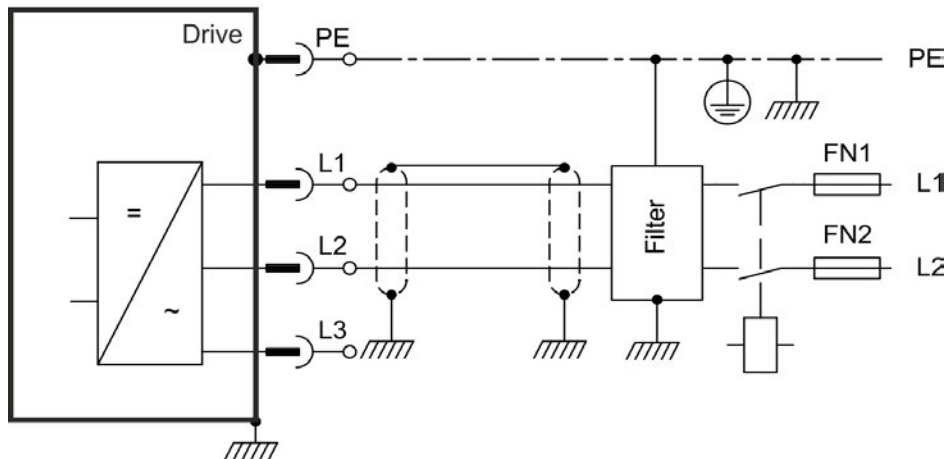
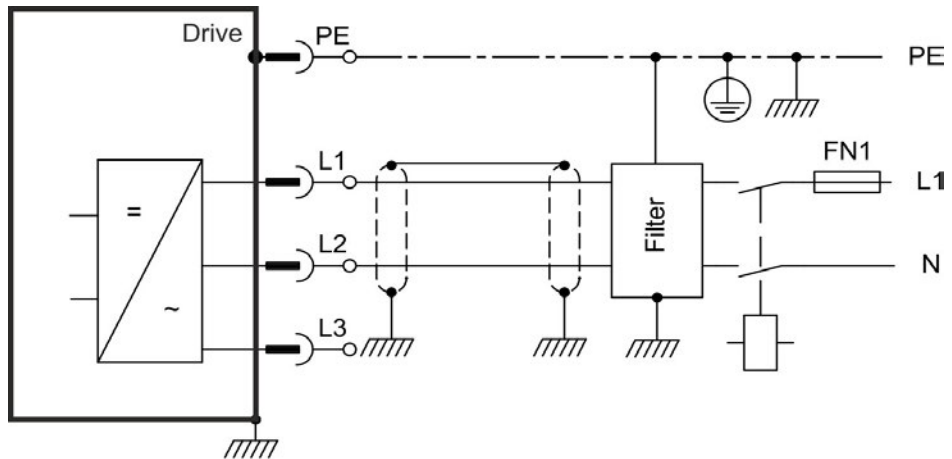

8.9 DC Bus link (X3, X14)

The DC bus link can be connected in parallel so that the regen power is divided between all the drives that are connected to the same DC bus link circuit. Every drive must have its own power connection to mains voltage, even if the DC bus link is used. Drives working regeneratively very often should be placed beside drives, which need energy. That reduces current flow on longer distances. For fuse type definition refer to (→ # 38).

- The sum of the rated currents for all of the drives connected in parallel to an **AKD-x003 to 024** must not exceed 48 A.

Use 6 mm², unshielded single cores with a max. length of 200 mm; use 6 mm² shielded cables for longer lengths. In this case no fuse for line protection is required.

- The sum of the rated currents for all of the **AKD-x048** connected in parallel to an AKD-x048 must not exceed 96 A. AKD-x048 should be connected in parallel only with AKD-x048 drives. Use 16 mm², unshielded single cores with a max. length of 30 mm; use 16 mm² shielded cables for longer lengths.

NOTICE

The drives can be destroyed, if DC bus link voltages are different. Only drives with mains supply from the same mains (identical mains supply voltage) may be connected by the DC bus link. DC bus link connection of AKD-x048 to other drives than AKD-x048 is not allowed.

NOTICE

The phase lost/ main control is not working on DC-Bus connected drives. A phase lost on a drive inside a DC Bus connection will be not detected. External phase monitoring to prevent overload of the rectifier is recommended.

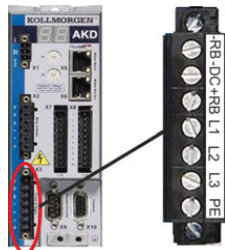

AKD-x00306 to AKD-x00606 (X3)		
Pin	Signal	Description
2	-DC	DC-Link Bus negative
3	+DC (+RB)	DC-Link Bus positive



AKD-x01206 (X3)		
Pin	Signal	Description
3	-DC	DC-Link Bus negative
4	+DC (+RB)	DC-Link Bus positive



AKD-x02406 & AKD00307 to AKD02407 (X3)		
Pin	Signal	Description
3	-DC	DC-Link Bus negative
4	+DC (+RB)	DC-Link Bus positive

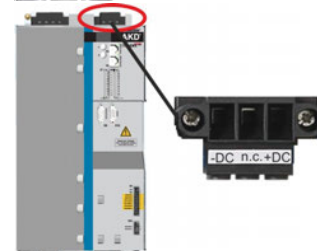

AKD-x04807 (X14)		
Pin	Signal	Description
1	-DC	DC-Link Bus negative
2	n.c.	not connected
3	+DC	DC-Link Bus positive

NOTE: Should be connected in parallel only with AKD-x048 drives.

8.9.1 DC Bus topology with Y connectors (24 A max.)

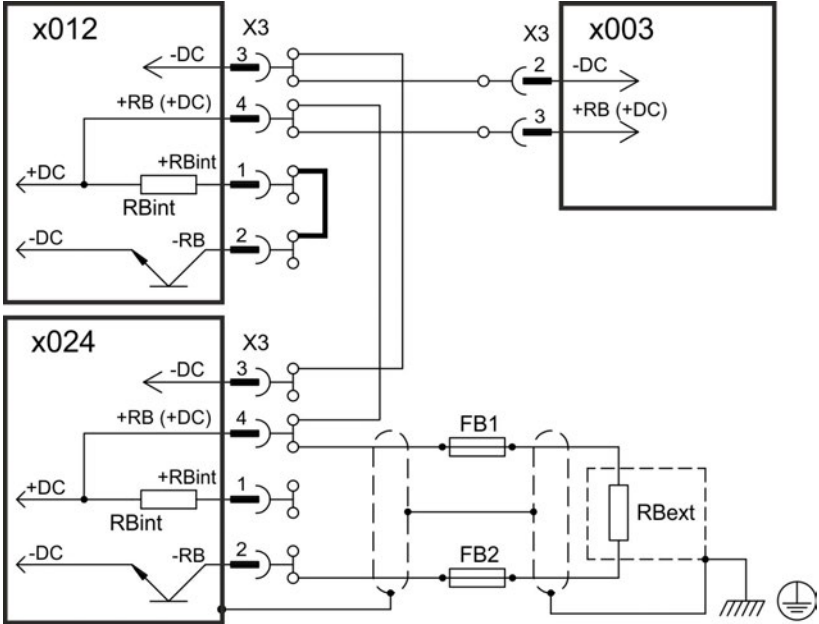

Without DC Bus fuses, other devices can become damaged or destroyed if, for example, a device fails due to an internal short circuit. If multiple drives are connected in parallel, then it is usual to insert DC Bus fuses ((→ # 38).) between groups of drives (with a group consisting of two or three devices, depending on the current) in order to limit any possible resulting damage. Fuses cannot avoid damage by current peaks completely.

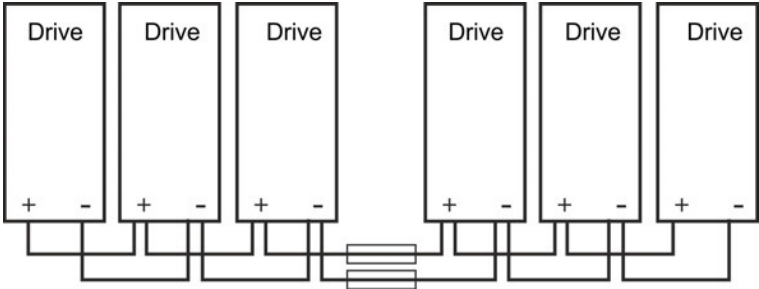

8.9.2 DC Bus topology with busbar

This wiring does not require Y connectors. If a device fails due to a short-circuit, only its DC Bus fuses ((→ # 38).) are tripped and the rest of the network continues uninterrupted. The solid busbars can conduct significantly larger currents, because the compensating current does not flow through the connector as above. For this reason, almost as many drives as desired can be connected in parallel in this form. This arrangement is frequently also useful for connecting KCM capacitor modules.

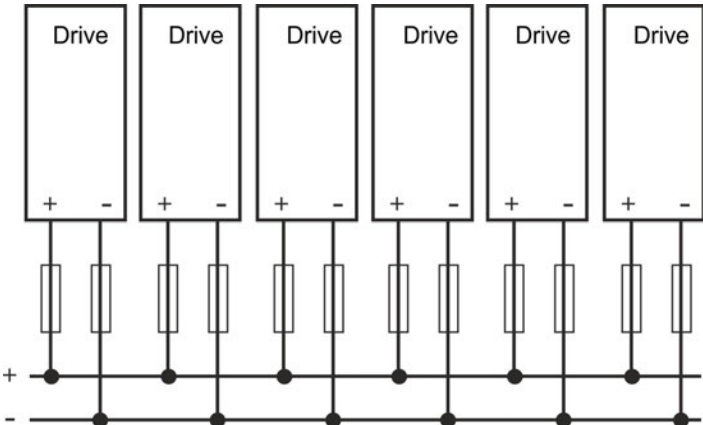

8.9.3 External regen resistor (X3)

For technical data on the brake circuit (→ #41).

8.9.3.1 AKD-x003 to 024, regen connector X3

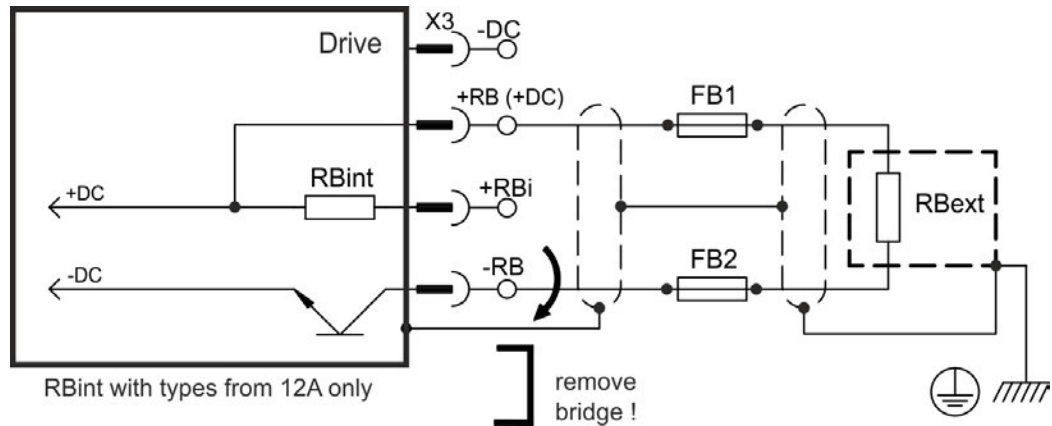

FB1 / FB2 fusing

Drive Model	Ampere rating@230V	Ampere rating@480V	UL region example:	CE Region example (Siba):
AKD-x003 to 012	10A	40A	Bussmann	110V to 400V: gRL(gS)
AKD-x024	15A	50A	FWP-xxA14F	400V to 480V: aR

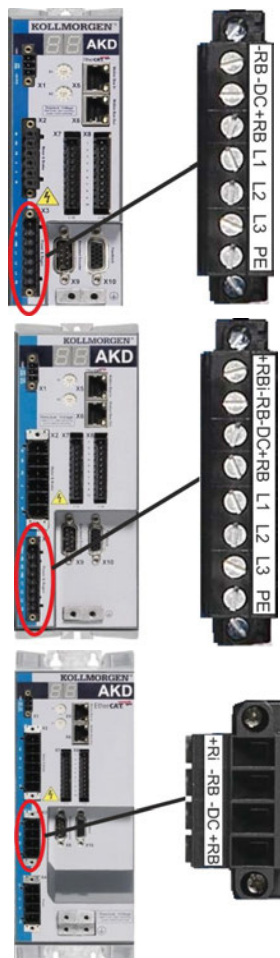

AKD-x00306 to AKD-x00606 (X3)		
Pin	Signal	Description
1	-RB	External Regen Resistor negative
3	+RB	External Regen Resistor positive

AKD-x1206 (X3)		
Pin	Signal	Description
1	+Rbint	Internal Regen Resistor positive
2	-RB	External Regen Resistor negative
4	+RB	External Regen Resistor positive

AKD-x02406 & AKD-x-00307 to 02407 (X3)		
Pin	Signal	Description
2	-RB	External Regen Resistor negative
4	+RB	External Regen Resistor positive

8.9.3.2 AKD-x048, regen connector X3

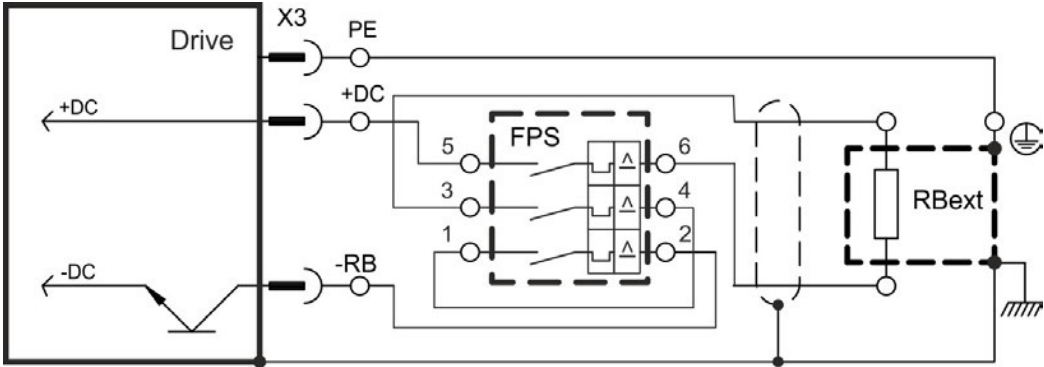

FPS: Fritzen DC Powerswitch

RBext	FPS	Range [In]	cable cross section
BAS(U)2000-10	FPS-16	10 to 16 A	min. 2.5 mm ²
BAS(U)3000-10	FPS-20	16 to 20 A	min. 4 mm ²
BAS(U)6000-10	FPS-25	20 to 25 A	min. 4 mm ²

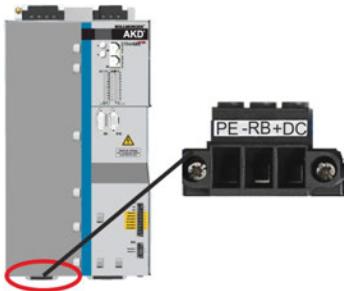

AKD-x04807		
Pin	Signal	Description
1	PE	Protective Earth
2	-RB	External Regen Resistor negative
3	+DC	External Regen Resistor positive

8.9.4 Capacitor Modules (X3)



KCM modules (**K**OLL**M**OR**G**EN **C**apacitor **M**odules) absorb kinetic energy generated by the motor when it is operating in generator mode. Normally, this energy is dissipated as waste via regen resistors. KCM modules, however, feed the energy they have stored back into the DC Bus link as and when it is required.

Assembly information: see regional accessories manual or KCM instruction manual.

Dimensions (HxWxD) : 300x100x201 mm

KCM-S	Saves energy: The energy stored in the capacitor module during generative braking is available the next time acceleration happens. The module's inception voltage is calculated automatically during the first load cycles.
KCM-P	Power in spite of power failure: If the power supply fails, the module provides the servo amplifier with the stored energy that is required to bring the drive to a standstill in a controlled manner (this only applies to the power supply voltage; battery-back the 24 V supply separately).
KCM-E	Expansion module for both applications. Expansion modules are available in two capacitance classes.

NOTE

The KCM modules may only be connected to AKD with 400/480 V rated voltage and a maximum rated current of 24 A. KCM modules cannot be connected to AKD-x048 drives. Mounting, installation, and setup instructions can be found in the Instructions Manual of the KCM Modules.



DANGER

DC Bus link terminals in servo systems carry high DC voltage of up to 900 V. Touching the terminals while they are carrying voltage is extremely dangerous. Switch off (disconnect) the line voltage. You must only work on the connections when the system is disconnected.

It can take over an hour for the modules to self-discharge. Check the state of charge with a measuring device that is suitable for a DC voltage of up to 1,000 V. When measuring a voltage of over 50 V between the DC+/DC- terminals or to ground, discharge the modules (see (→ # 113)).

8.9.4.1 Technical Data

Type	Storage-Capacity [Ws]	Rated Supply Voltage [V DC]	Peak Supply Voltage [V DC]	Power [kW]	Protection Class	Inception Voltage [V DC]	Weight [kg]
KCM-S200	1600	max. 850	max. 950 (30s in 6 min)	18	IP20	evaluated	6.9
KCM-P200	2000					470	6.9
KCM-E200	2000					-	4.1
KCM-E400	4000					-	6.2

8.9.4.2 Example installation with KCM-S and KCM-E

NOTICE

Maximum cable length between AKD and KCM: 500mm. The DC+ and DC- lines should always be twisted, maximum cross section is 6mm². Ensure that the polarity is correct, swapping round DC+/DC- will damage the KCM modules.

Connect the BR connection to the AKD with the most frequent generative braking processes in the system. This AKD must have an active internal or external brake resistor. Create a motion profile that causes the brake chopper to respond.

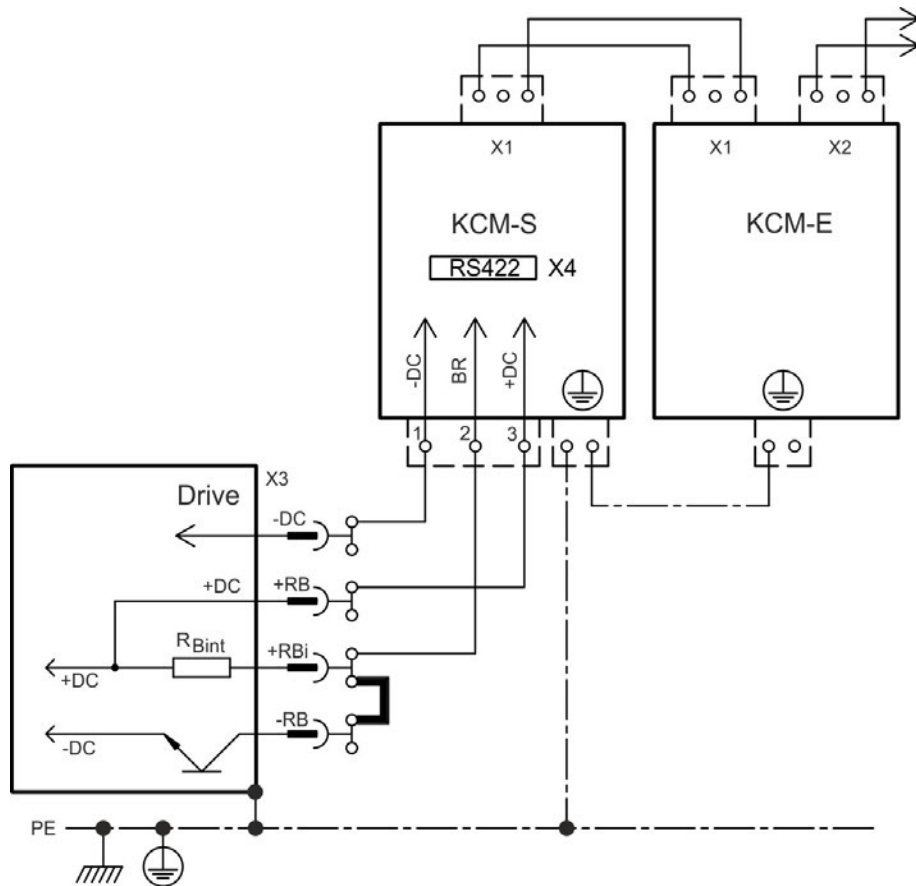

Setup KCM-S and KCM-E

Prerequisite for the following instructions:

- Properly disconnected, grounded system.
- KCM-S: assembled and wired in the switching cabinet. The load that leads to the activation of the brake chopper during braking must be connected.
- KCM-E: assembled and connected to the KCM-S with connection cable (X1) and PE line.
- Discharge aids (plug-in bridge) are removed.

Proceed as instructed below:

1. Switch on the line voltage after the drive has finished the 24V boot process.
2. Enable the AKD and operate the motion profile that causes the brake chopper to respond.
3. The KCM-S determines the chopper threshold and begins to charge; LED (top view) flashes. The energy stored in the capacitor module during generative braking is available the next time acceleration happens.

RS422 interface X4 allows data exchange controlled by a terminal software of your choice. Interface setting: 115200 Baud, 8 Data Bits, 1 Stop Bit, No Parity&Flow Control. The X4 mating connector is in the package. More information is given in the KCM Instructions Manual.

8.9.4.3 Example installation with KCM-P and KCM-E

NOTICE

Maximum cable length between AKD and KCM: 500mm. The DC+ and DC- lines should always be twisted, maximum cross section is 6mm². Ensure that the polarity is correct, swapping round DC+/DC- will damage the KCM modules.

The KCM-P starts the charging process at approx. 470 V DC. If the power supply fails, the module provides the DC bus link with the stored energy (this only applies to the power supply voltage; battery-back the 24 V supply separately).

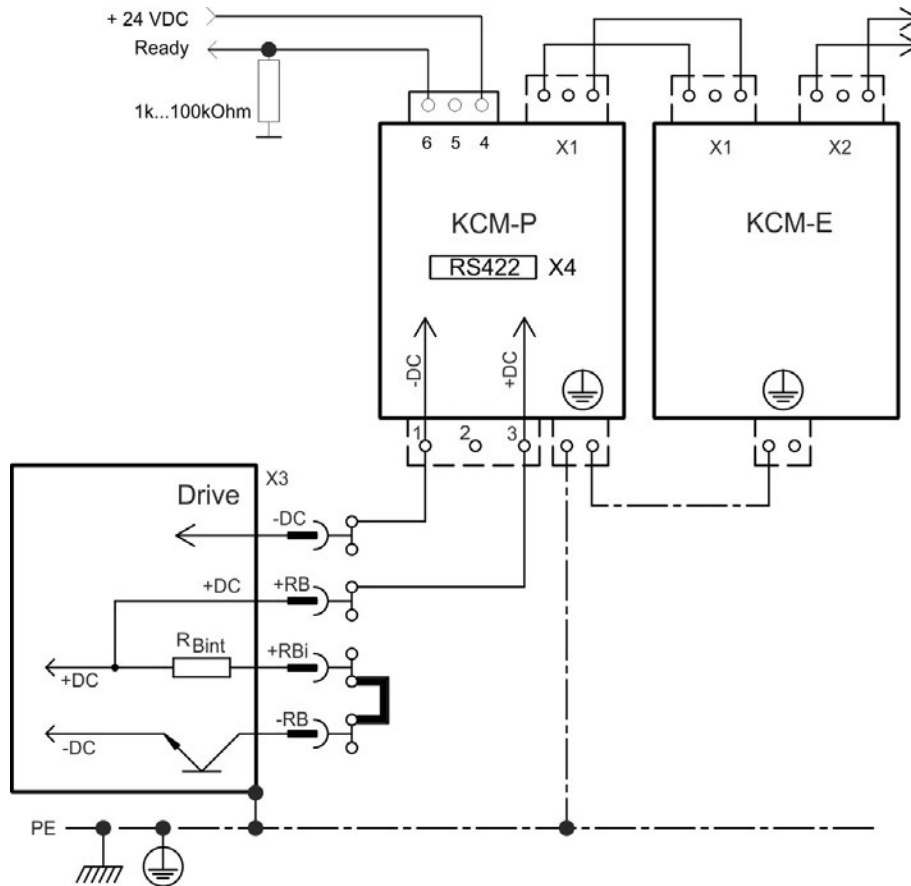

Setup KCM-P and KCM-E

Prerequisite for the following instructions:

- Properly disconnected, grounded system.
- KCM-P: assembled and wired in the switching cabinet. Set AKD undervoltage limit VBUS.UVTHRESH to a value significantly below 470V DC, otherwise AKD will switch-off before KCM-P provides energy to the DC bus link.
- KCM-E: assembled and connected to the KCM-P with connection cable (X1) and PE line.
- Discharge aids (plug-in bridge) are removed.

Proceed as instructed below:

1. Switch on the line voltage after the drive has finished the 24V boot process.
2. The KCM-P begins the charging process at approximately 470 V DC; the LED flashes.

RS422 interface X4 allows data exchange controlled by a terminal software of your choice. Interface setting: 115200 Baud, 8 Data Bits, 1 Stop Bit, No Parity&Flow Control.

The X4 mating connector is in the package.

The ready signal reports the ready to operate (high level).

More information is given in the KCM Instructions Manual.

8.9.4.4 Discharging KCM modules

The aids supplied with each KCM module (plug-in bridge/connecting cables) allows discharging the modules safely.

NOTICE

When the charging LED on top of the modules flashes, the capacitors are charged. Please note, however, that the LED does not allow you to draw a definite conclusion about the state of discharge, as it is not monitored for failures.



DANGER

DC Bus link terminals in servo systems carry high DC voltage of up to 900 V. Touching the terminals while they are carrying voltage is extremely dangerous.

Switch off the line voltage (disconnect the system). You must only work on the connections when the system is disconnected.

Check the state of charge of the capacitors with a measuring device that is suitable for a DC voltage of up to 1,000 V. Wait until the voltage measured between the DC+/DC- terminals or to ground has dropped below 50 V. It can take over an hour for the modules to self-discharge. If you cannot wait for the duration of the self-discharge time, you must force the modules to discharge.

You must follow the procedure described below when forcing the modules to discharge.

For your own safety, proceed as follows when forcing the modules to discharge:

1. Switch off (disconnect) the line voltage.
2. Discharge the modules:
 - KCM-S/-P:** Insert the plug-in bridge in the screw terminals (black-1 to gray-2) on the base of the modules, wait at least 70 s, leave the plug-in bridge in place (as a means of securing for transport). Remove the plug-in bridge again before recommissioning.
 - KCM-E:** Bridge the X2/X3 connector with a connecting cable on the top of the module, wait at least 70 s, leave the connecting cable in place (as a means of securing for transport). Detach the connecting cable and reconnect the KCM-E properly before recommissioning.
3. Perform the scheduled task (e.g., cleaning, maintenance, or uninstallation).

8.10 Motor Power Connection (X2)

Together with the motor supply cable and motor winding, the power output of the drive forms an oscillating circuit. Characteristics such as cable capacity, cable length, motor inductance, and frequency (→ # 35) or (→ # 36) determine the maximum voltage in the system.

The AKD drive is able to protect the connected motor from overloading, if the parameters are set correctly and the thermal protection sensor is connected and supervised. With Kollmorgen motors the valid data are automatically set by the internal motor database. With motors from other manufacturers the data from the nameplate must be entered to the referring fields in the motor view of the Kollmorgen setup software WorkBench.

NOTICE

The dynamic voltage rise can lead to a reduction in the motor operating life and, on unsuitable motors, to flashovers in the motor winding.

- Only install motors with insulation class F (acc. to IEC60085) or above.
- Only install cables that meet the requirements (→ # 40).

NOTICE

With long motor cables leakage currents endanger the output stage of the drive. For cable lengths from 25 m to 50 m, a motor choke (3YL) must be wired into the motor cable (near the drive). Refer to your regional Accessories Manual for Kollmorgen chokes.

Cable length ≤ 25 m

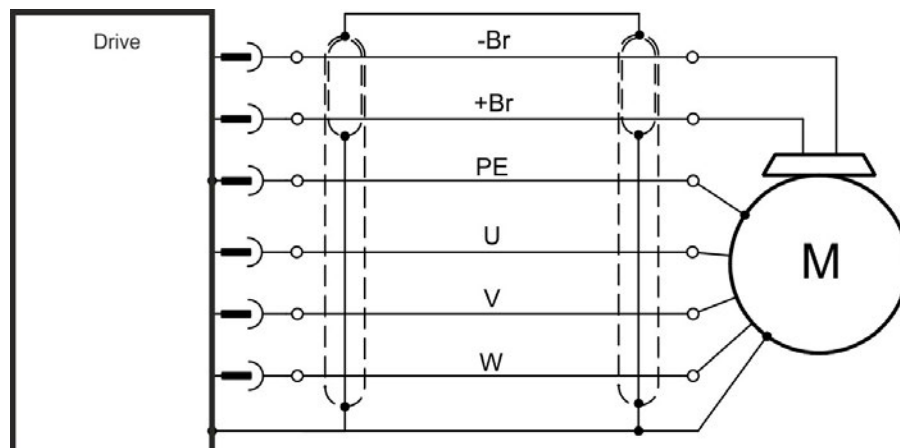

Cable length >25 m

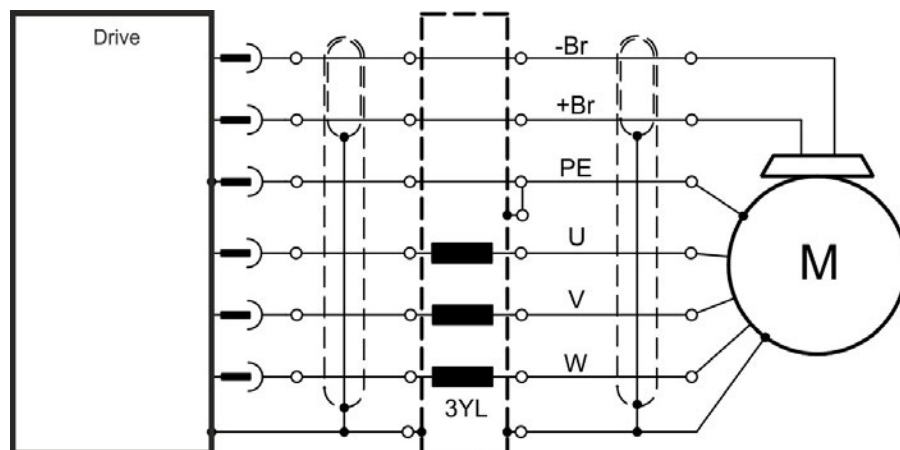

8.10.1 AKD-x003 to 024, power connector X2

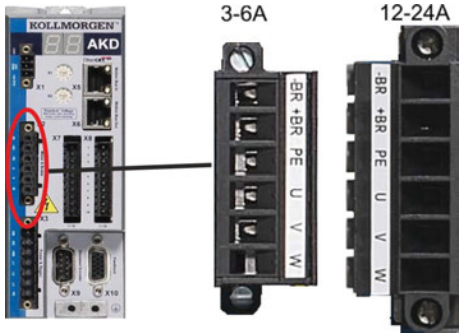

Pin	Signal	Description
1	-BR	Motor holding brake (→ # 116)
2	+BR	Motor holding brake (→ # 116)
3	PE	Protective earth (motor housing)
4	U	Motor phase U
5	V	Motor phase V
6	W	Motor phase W

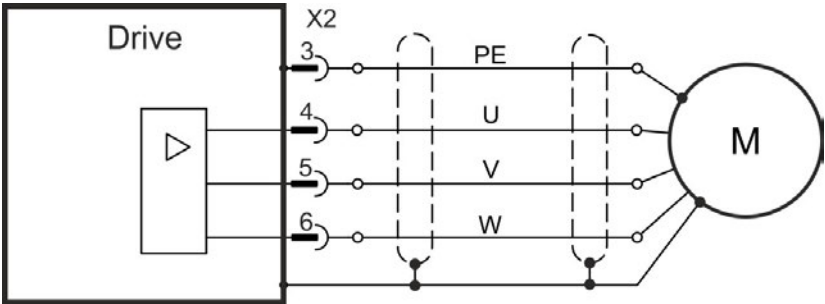

8.10.2 AKD-x048, power connector X2

NOTE Cable length maximum 25 m.

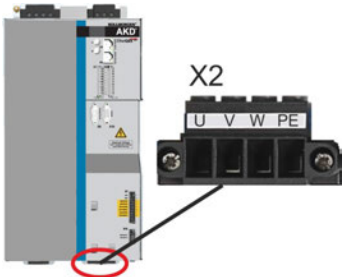

Pin	Signal	Description
1	U	Motor phase U
2	V	Motor phase V
3	W	Motor phase W
4	PE	Protective earth (motor housing)

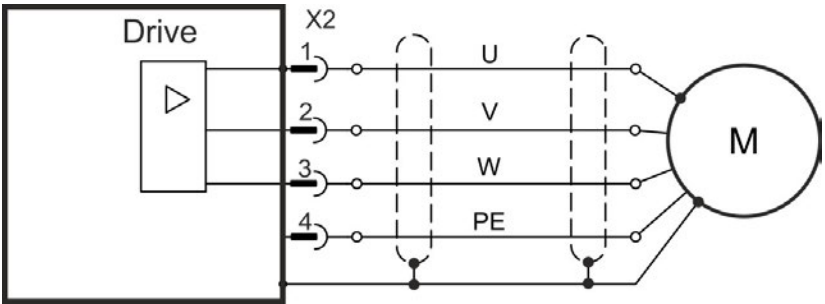

8.11 Motor Brake Connection (X2, X15, X16)

A 24 V holding brake in the motor can be controlled directly by the drive. For proper function, check voltage drop, measure voltage at brake input and check brake function (on and off).



CAUTION

This function does not ensure functional safety. Functional safety requires and additional, external mechanical brake, operated by a safety controller. The Hardware Enable (connector X8 pin 4) does not initiate a controlled stop but switches off the power stage immediately.

Set parameter MOTOR.BRAKEIMM to 1 with vertical axes, to apply the brake immediately after faults or Hardware Disable.

8.11.1 AKD-x003 to 024, brake connector X2

Pin	Signal	Description
1	-BR	Motor holding brake, negative
2	+BR	Motor holding brake, positive
3	PE	Protective earth (→ # 114)
4	U	Motor phase U (→ # 114)
5	V	Motor phase V (→ # 114)
6	W	Motor phase W (→ # 114)

Brake voltage supply via 24 V ±10% auxiliary voltage supply of the drive on X1. Maximum current depends on the drive type, see Technical Data (→ # 35) or (→ # 36).

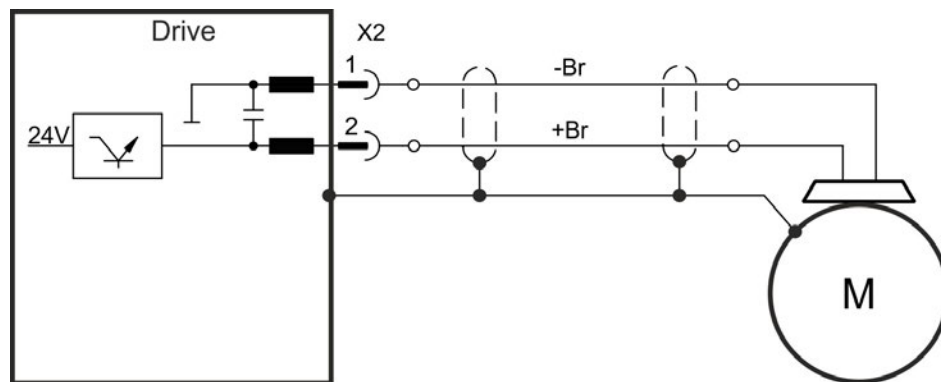

8.11.2 AKD-x048, brake connectors X15, X16

AKD-x048 the brake voltage supply is separated from the drive auxiliary voltage. Maximum brake current is 2 A. Use X15 for 24 VDC $\pm 10\%$ supply input and X16 to connect the motor holding brake.

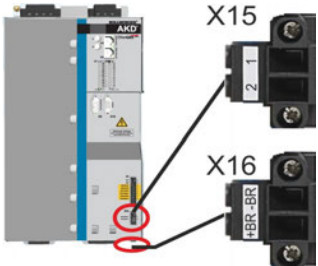

X15	Signal	Description
1	24V	24V supply voltage, brake
2	GND	GND, brake
X16	Signal	Description
1	-BR	Motor holding brake, negative
2	+BR	Motor holding brake, positive

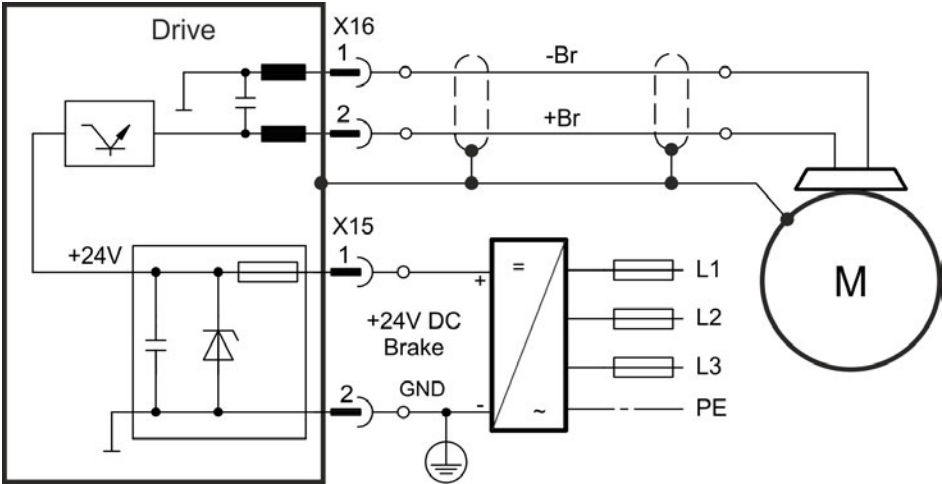

8.11.3 Functionality

The brake function must be enabled through a parameter. The diagram below shows the timing and functional relationships between the controlled stop signal, speed, and braking force. All values can be adjusted with parameters; values in the diagram are default values.

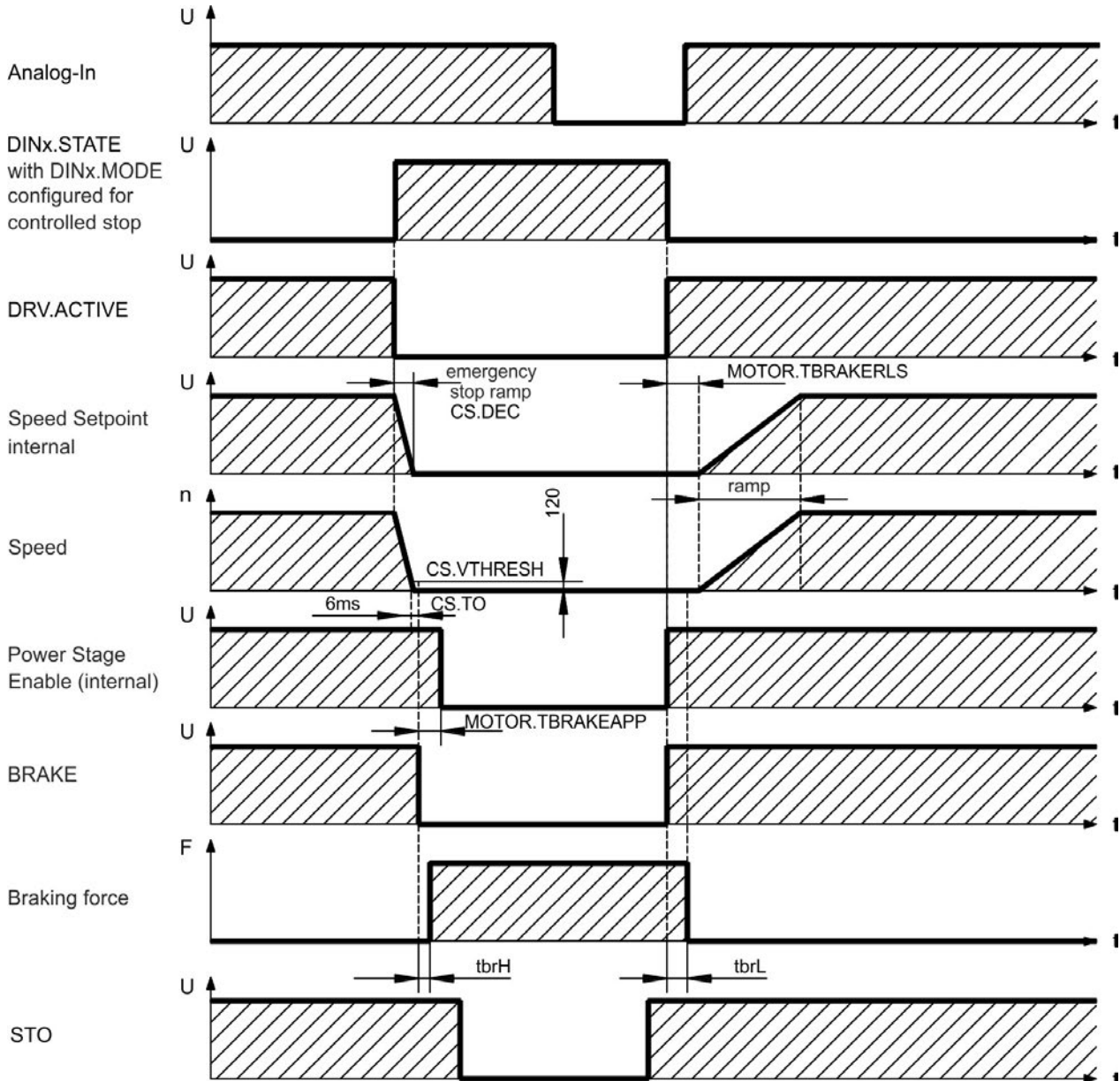

The speed setpoint of the drive is internally driven down an adjustable ramp (CS.DEC) to 0 V.

With default values the output for the brake is switched on when the speed has reached 120 rpm (CS.VTHRESH) for at least 6 ms (CS.TO). The rise (t_{brH}) and fall (t_{brL}) times of the holding brake that is built into the motor are different for the various types of motor.

8.12 Feedback Connection (X10, X9, X7)

Every closed servo system normally requires at least one feedback device for sending actual values from the motor to the drive. Depending on the type of feedback device used, information will be fed back to the drive using digital or analog means.

AKD supports the most common types of feedback device. Feedback functions are assigned with parameters in WorkBench, the setup software. Scaling and other settings are also performed in WorkBench. For a detailed description of the parameters, please refer to the WorkBench online help.

The table below provides an overview of the supported feedback types, their corresponding parameters, and a reference to the relevant connection diagram in each case.

Feedback Types	Wiring	Connector	FB1. SELECT	FB2. MODE	FB3. MODE
Resolver	(→ # 122)	X10	40	-	-
SFD	(→ # 123)	X10	41	-	-
SFD3	(→ # 124)	X10	45	-	-
Encoder Hiperface DSL	(→ # 125)	X10	46	-	-
SinCos Encoder BiSS B (analog)	(→ # 126)	X10	32	-	-
Encoder BiSS C (digital)	(→ # 127)	X10	34	-	-
SinCos Encoder ENDAT 2.1	(→ # 128)	X10	30	-	-
Encoder ENDAT 2.2	(→ # 129)	X10	31	-	-
Encoder ENDAT 2.2	(→ # 130)	X9/X8	-	-	0
Encoder ENDAT 2.2	(→ # 139)	X9	-	-	0
SinCos Encoder Hiperface	(→ # 131)	X10	33	-	-
Sine Encoder + Hall	(→ # 132)	X10	20	-	-
Sine Encoder	(→ # 132)	X10	21	-	-
Incremental Encoder + Hall	(→ # 133)	X10	10	-	-
Incremental Encoder	(→ # 133)	X10	11	-	-
Hall Sensors	(→ # 134)	X10	12	-	-
Tamagawa Smart Abs	(→ # 135)	X10	42	-	-
Incremental Encoder, FB2.SOURCE=1	(→ # 138)	X9	-	0	-
Incremental Encoder, FB2.SOURCE=2	(→ # 138)	X7	-	0	-
Pulse/Direction, FB2.SOURCE=1	(→ # 140)	X9	-	1	-
Pulse/Direction, FB2.SOURCE=2	(→ # 140)	X7	-	1	-
CW/CCW, FB2.SOURCE=1	(→ # 141)	X9	-	2	-
CW/CCW, FB2.SOURCE=2	(→ # 141)	X7	-	2	-

8.12.1 Feedback connector (X10)

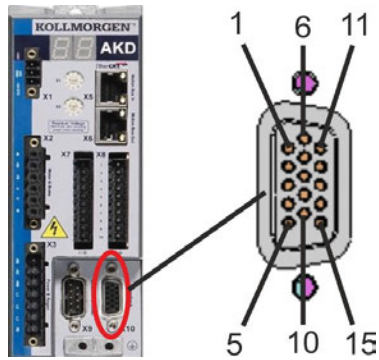

Pin	SFD	SFD3/DSL	Resolver	BiSS B (analog)	BiSS C (digital)	EnDAT 2.1	EnDAT 2.2	Hiper-face	Sine Enc. +Hall	Incr. Enc. +Hall	Hall	Tamagawa Smart Abs*
1	-	-	-	-	-	-	-	-	Hall U	Hall U	Hall U	-
2	-	-	-	CLK+	CLK+	CLK+	CLK+	-	Hall V	Hall V	Hall V	-
3	-	-	-	CLK-	CLK-	CLK-	CLK-	-	Hall W	Hall W	Hall W	-
4	SEN+	-	-	SEN+	SEN+	SEN+	SEN+	SEN+	SEN+	SEN+	-	SEN+
5	SEN-	-	-	SEN-	SEN-	SEN-	SEN-	SEN-	SEN-	SEN-	-	SEN-
6	COM+	COM+	R1 Ref+	DAT+	DAT+	DAT+	DAT+	DAT+	Zero+	Zero+	-	SD+
7	COM-	COM-	R2 Ref-	DAT-	DAT-	DAT-	DAT-	DAT-	Zero-	Zero-	-	SD-
8	-	-	Thermal control (+)									
9	-	-	Thermal control (-)									
10	+5 V	+5 V	-	+5 V	+5 V	+5 V	+5 V	+8 to +9 V	+5 V	+5 V	+5 V	+5 V
11	0 V	0 V	-	0 V	0 V	0 V	0 V	0 V	0 V	0 V	0 V	0 V
12	-	-	S1 SIN+	A+	-	A+	-	SIN+	A+	A+	-	-
13	-	-	S3 SIN-	A-	-	A-	-	SIN-	A-	A-	-	-
14	-	-	S2 COS+	B+	-	B+	-	COS+	B+	B+	-	-
15	-	-	S4 COS-	B-	-	B-	-	COS-	B-	B-	-	-

CLK = CLOCK, DAT = DATA, SEN = SENSE, *= for AKD with "NB" (rev 8+) only

8.12.2 Feedback connector (X9)

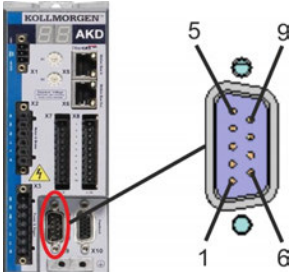

Pin	Pulse/Direction	CW/CCW	Incremental Encoder	Encoder with EnDat 2.2
1	Pulse+	CW+	A+	CLOCK+
2	Pulse-	CW-	A-	CLOCK-
3	GND	GND	GND	GND
4	Direction+	CCW+	B+	DATA+
5	Direction-	CCW-	B-	DATA-
6	Shield	Shield	Shield	Shield
7	-	-	Zero+	-
8	-	-	Zero-	-
9	-	-	+ 5 V (supply, output)	+5V (supply, output)

8.12.3 Feedback connector (X7)

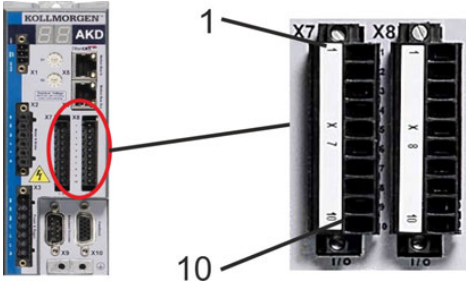

Pin	Pulse/Direction	CW/CCW	Incremental Encoder
9	Pulse	CW	Channel A
10	Direction	CCW	Channel B
1	Common	Common	Common

8.12.4 Resolver

The diagram below shows the connection of a resolver (2 to 36-poles) as a feedback system. The thermal control in the motor is connected via the Resolver cable and evaluated in the drive. If no thermal control is in the motor, the cable must short pins 8 and 9.

If cable lengths of more than 100 m are planned, please contact customer support.

Type	FBTYP	Description
Resolver	40	Accuracy: 14 bit (0.022°), resolution: 16 bit (0.006°)

The pin assignment shown on the Resolver end relates to Kollmorgen motors.

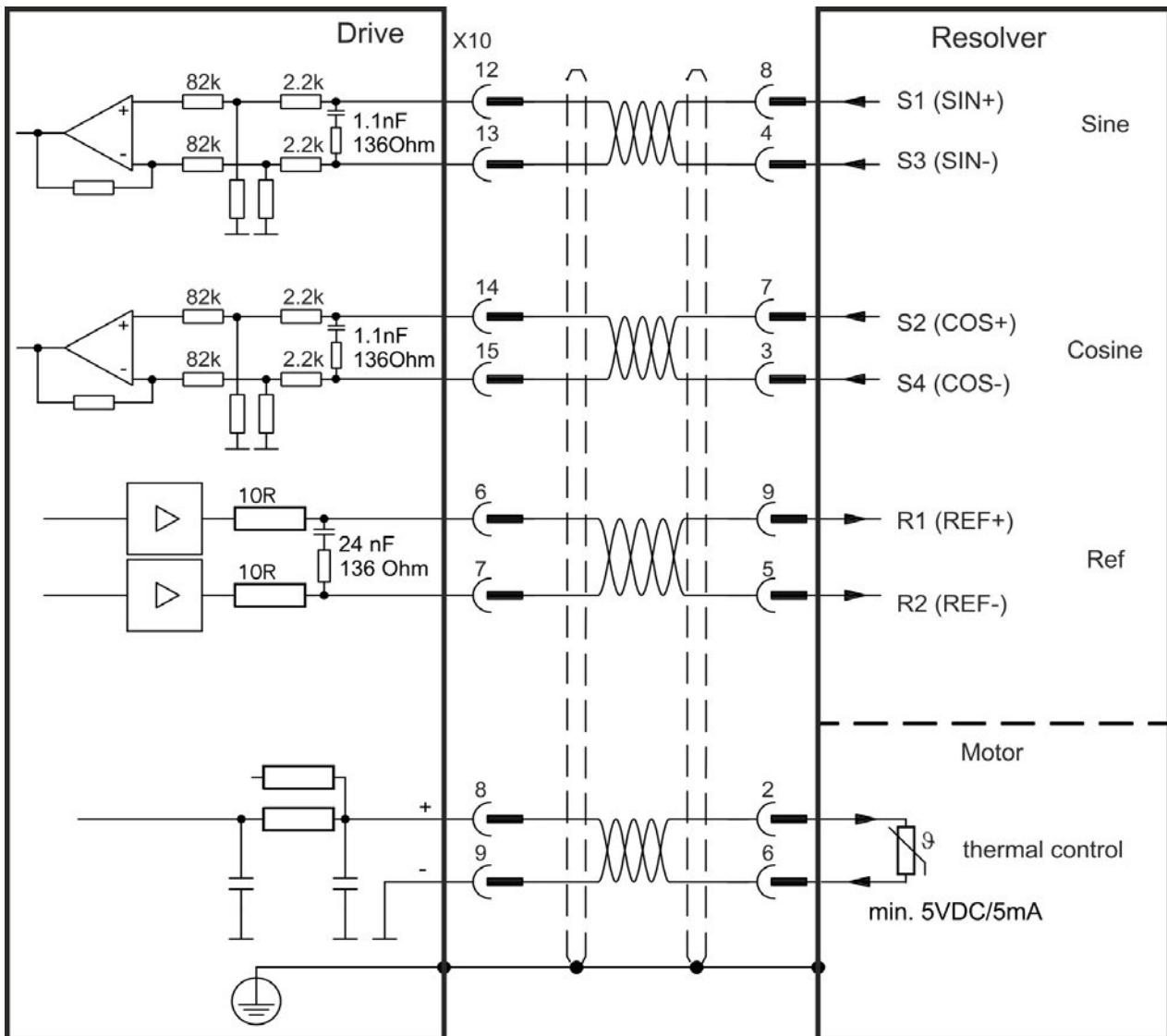

8.12.5 SFD

NOTE

The diagram below shows the connection of the four wire Kollmorgen SFD feedback system. When SFD cable total resistance for 5V out (Up) and 5V return (0V) is less than 3.3 Ohm, then remote sensing is not needed. For typical cable this means remote sensing is not needed up to 25 m. Kollmorgen cables are rated up to 50 m with no remote sensing.

Type	FBTYP	Up	Remarks
Smart Feedback Device (SFD)	41	5.1 V +/-5%	accuracy 14 bit (0.022°), resolution 24 bit (2 x 10E-5°)

The pin assignment shown on the SFD end relates to Kollmorgen motors.

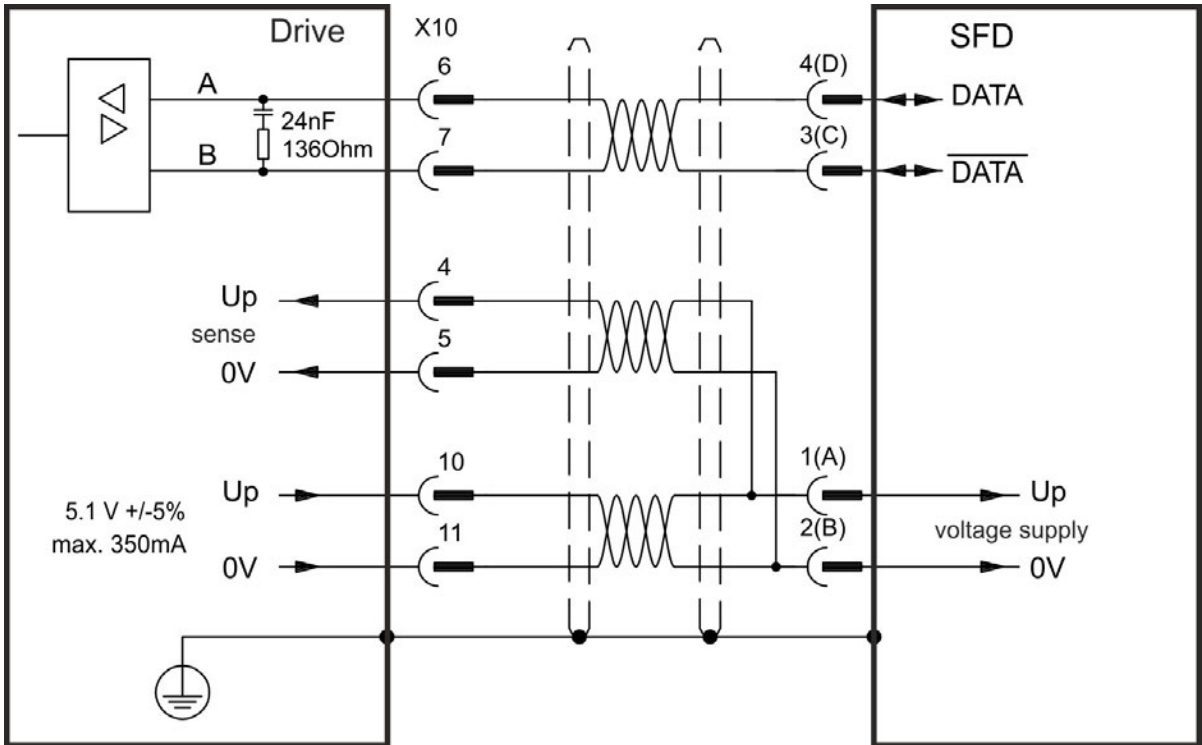

8.12.6 SFD3

The diagram below shows the connection of the two wire Kollmorgen SFD3 feedback system.

NOTE

SFD3 can be used with the special Kollmorgen cable.
Maximum cable length is up to 25 m.

Type	FATYPE	Up	Remarks
SFD3	45	8 to 9 V	from FW 1.11, with Kollmorgen Cables only

The pin assignment shown on the SFD3 end relates to Kollmorgen motors.

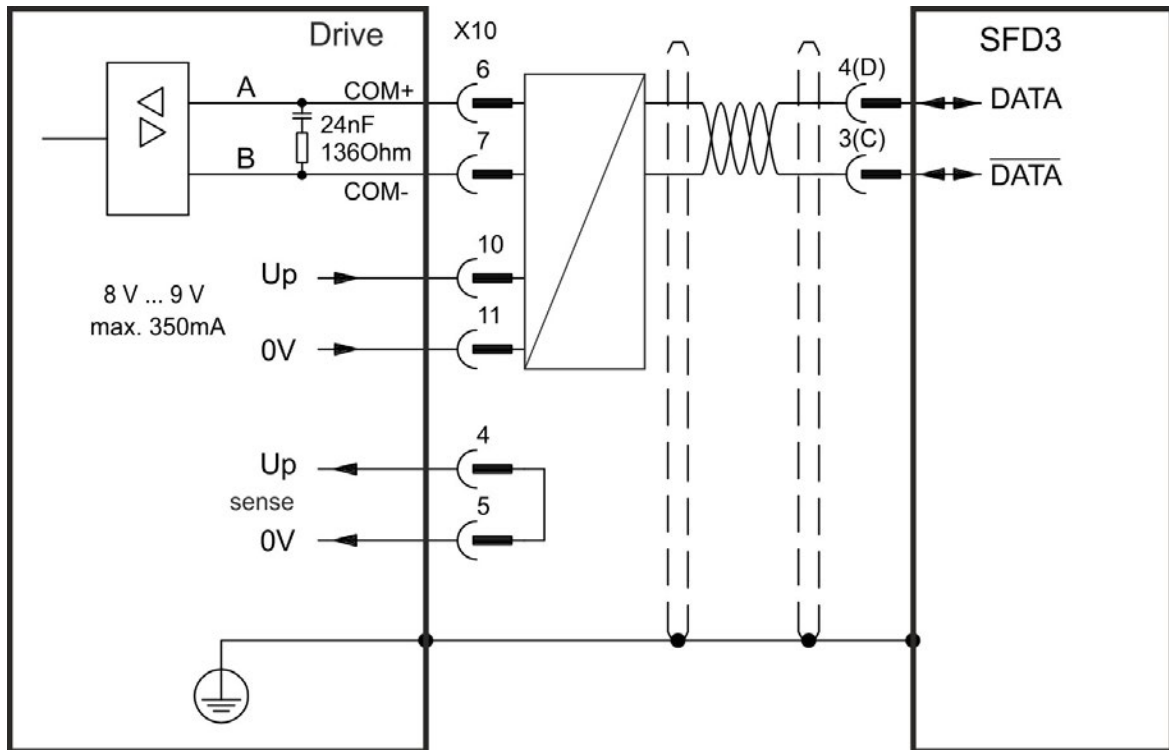

8.12.7 Hiperface DSL

The diagram below shows the connection of the two wire Hiperface DSL feedback system.
NOTE Hiperface DSL can be used with the special Kollmorgen cable.
 Maximum cable length is up to 25 m.

Type	FBTYP	Up	Remarks
Hiperface DSL	46	8 to 9 V	from FW 1.9, with Kollmorgen Cables only

The pin assignment shown on the DSL end relates to Kollmorgen motors.

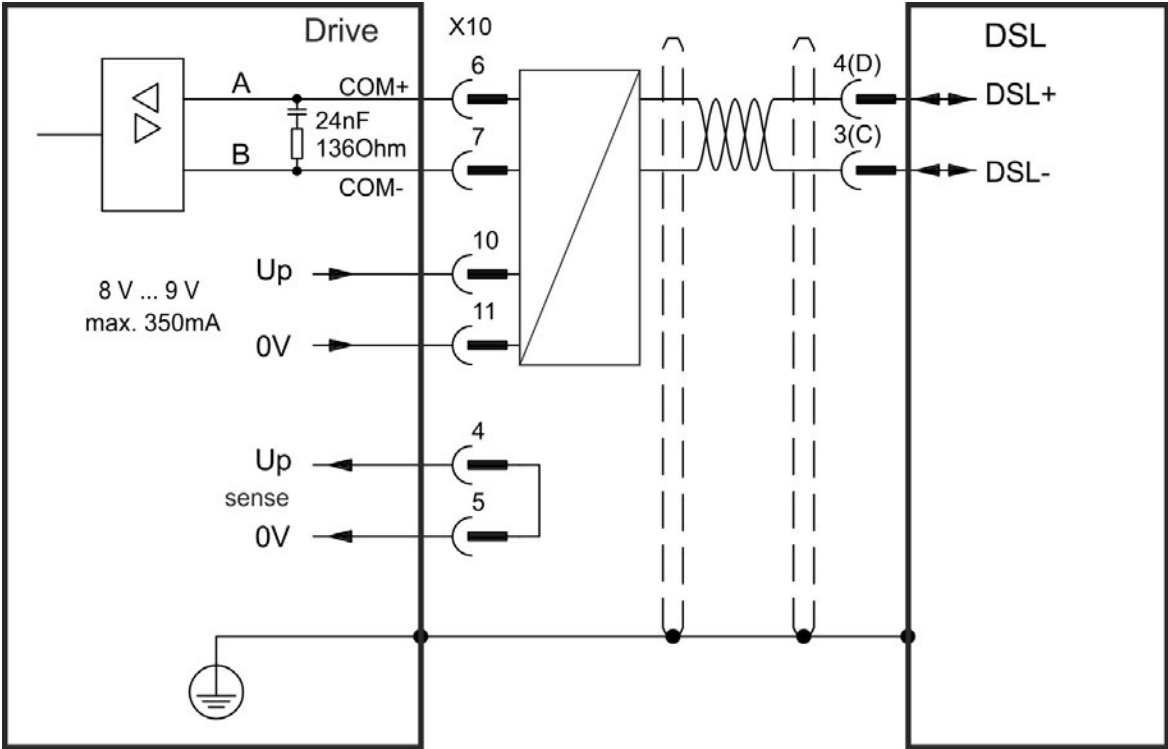

8.12.8 Encoder with BiSS

8.12.8.1 BiSS (Mode B) analog

The diagram below shows the wiring of a single-turn or multi-turn encoder with BiSS Mode B interface as a feedback system. The thermal control in the motor is connected via the encoder cable and evaluated in the drive.

If cable lengths of more than 50 m are planned, please consult customer support.

Type	FCTYPE	Up	Frequency Limit
BiSS (Mode B) Analog	32	5.1 V +/-5%	1 MHz, 250 kHz for encoders that require termination resistors

The pin assignment shown on the encoder end relates to Kollmorgen motors.

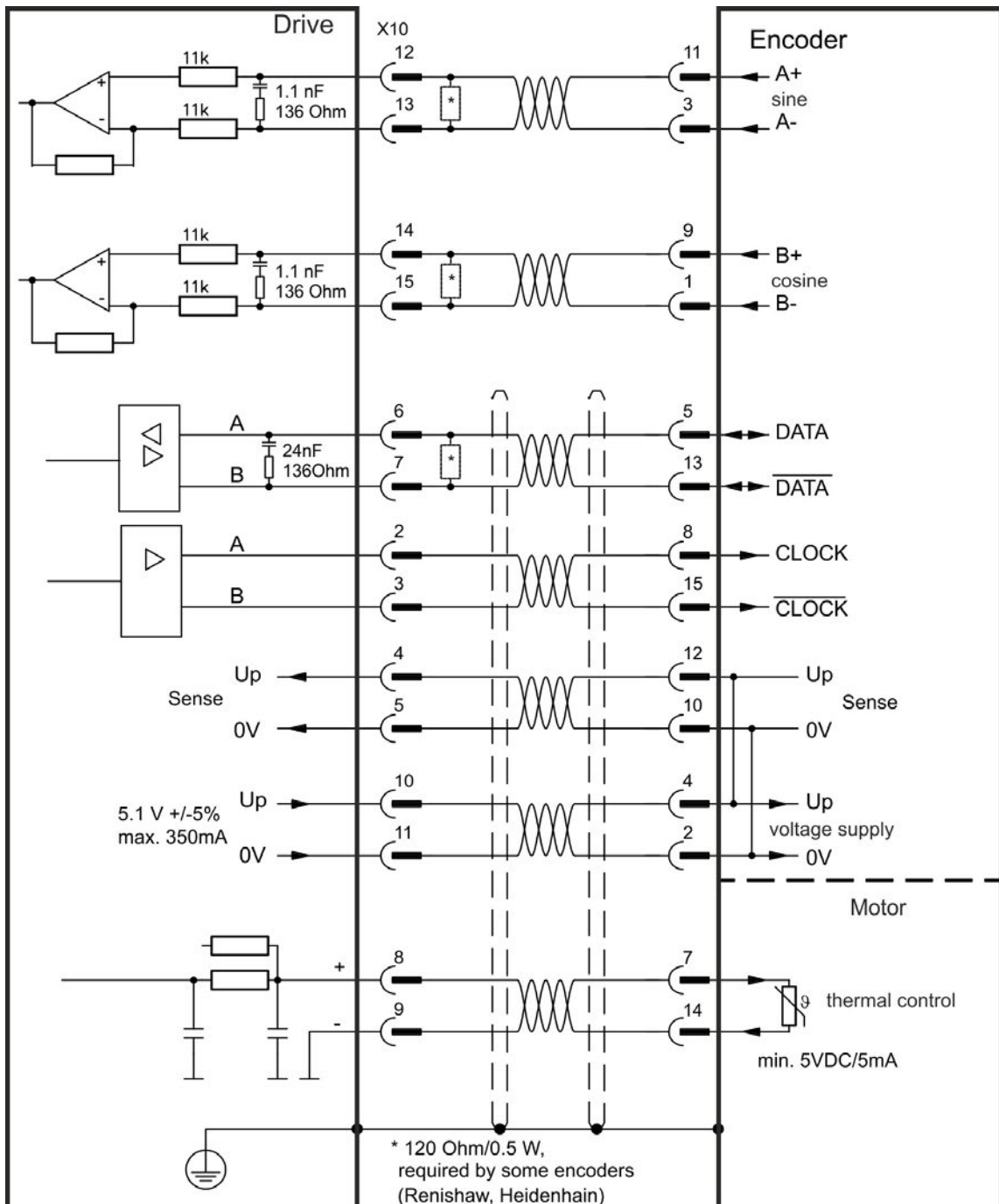

8.12.8.2 BiSS (Mode C) digital

The diagram below shows the wiring of a single-turn or multi-turn encoder with BiSS Mode C interface from Renishaw (specifically model Resolute RA26B) as a feedback system. The thermal control in the motor is connected via the encoder cable and evaluated in the drive. If cable lengths of more than 25 m are planned, please consult customer support.

Type	FCTYPE	Up	Frequency Limit
BiSS Mode C	34	5.1 V +/-5%	2.5 MHz

The pin assignment shown on the encoder end relates to Kollmorgen motors.

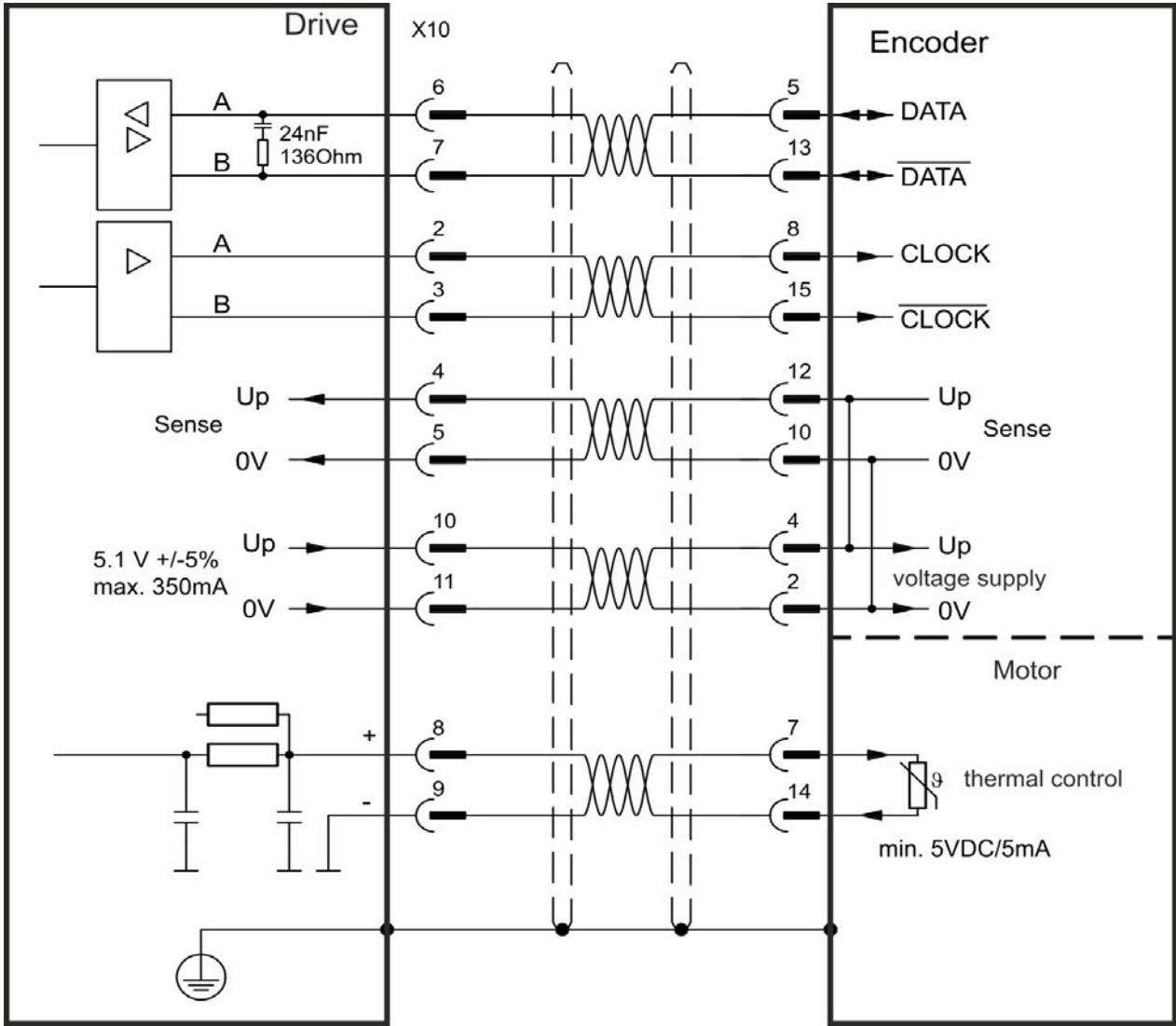

8.12.9 Sine Encoder with EnDat 2.1

The diagram below shows the wiring of a single-turn or multi-turn sine-cosine encoder with EnDat 2.1 interface as a feedback system. Preferred types are the ECN1313 and EQN1325 encoders. The thermal control in the motor is connected via the encoder cable and evaluated in the drive. All signals are connected using our pre-assembled encoder connection cable. If cable lengths of more than 50 m are planned, consult customer support.

Type	FATYPE	Frequency Limit
ENDAT 2.1	30	1 MHz, 250 kHz for encoders that require termination resistors

The pin assignment shown on the encoder end relates to Kollmorgen motors.

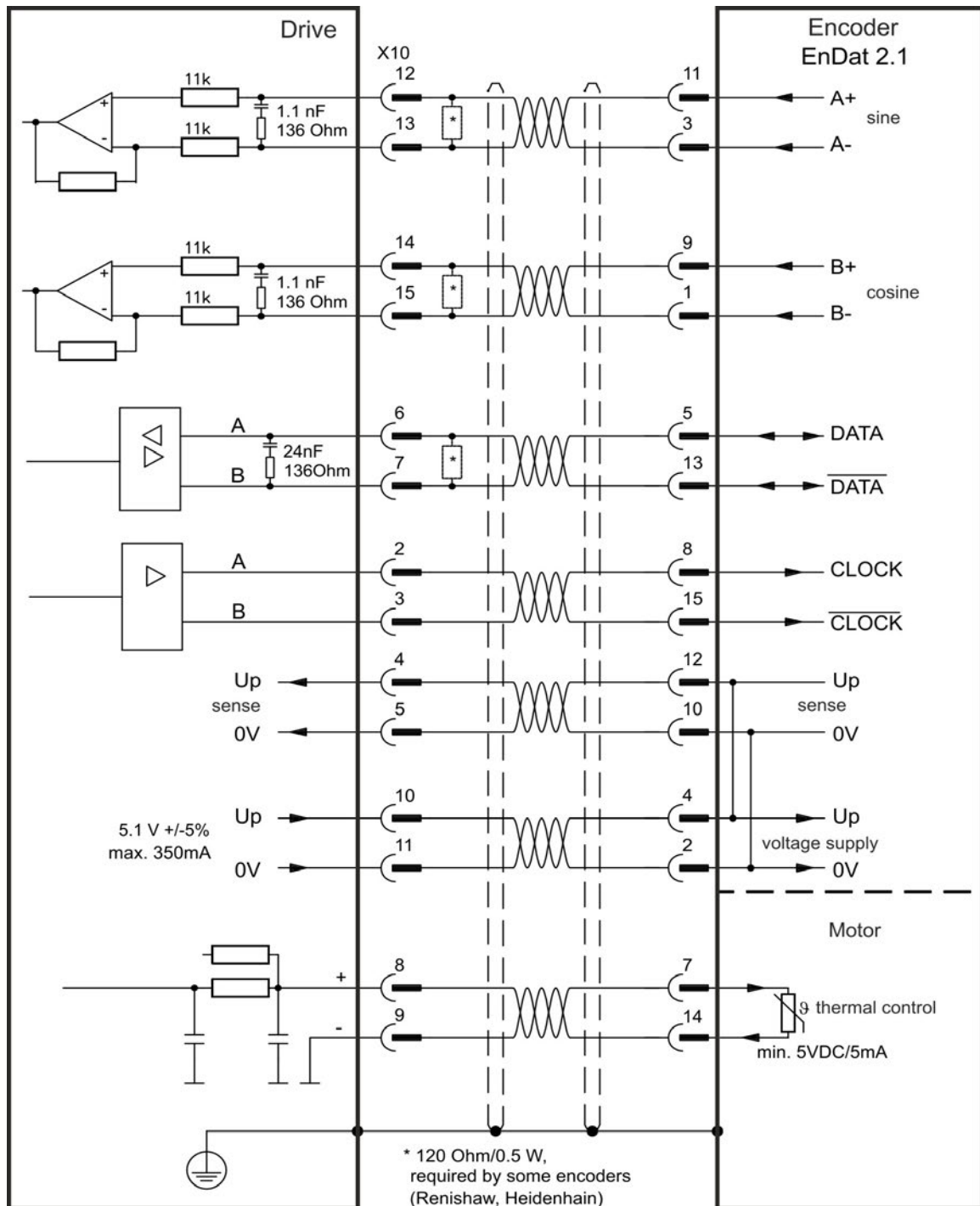

8.12.10 Encoder with EnDat 2.2

Single-turn or multi-turn encoders with EnDat 2.2 interface can be connected either to X10 or X9 as a primary motor feedback system.

8.12.10.1 Connection to X10

The thermal control in the motor is connected via the encoder cable and evaluated in the drive. All signals are connected using our pre-assembled encoder connection cable. If cable lengths of more than 50 m are planned, please consult customer support.

Type	FCTYPE	Frequency Limit	Description
ENDAT 2.2	31	1 MHz	Adjust on screen page FEEDBACK

The pin assignment shown on the encoder end relates to Kollmorgen motors.

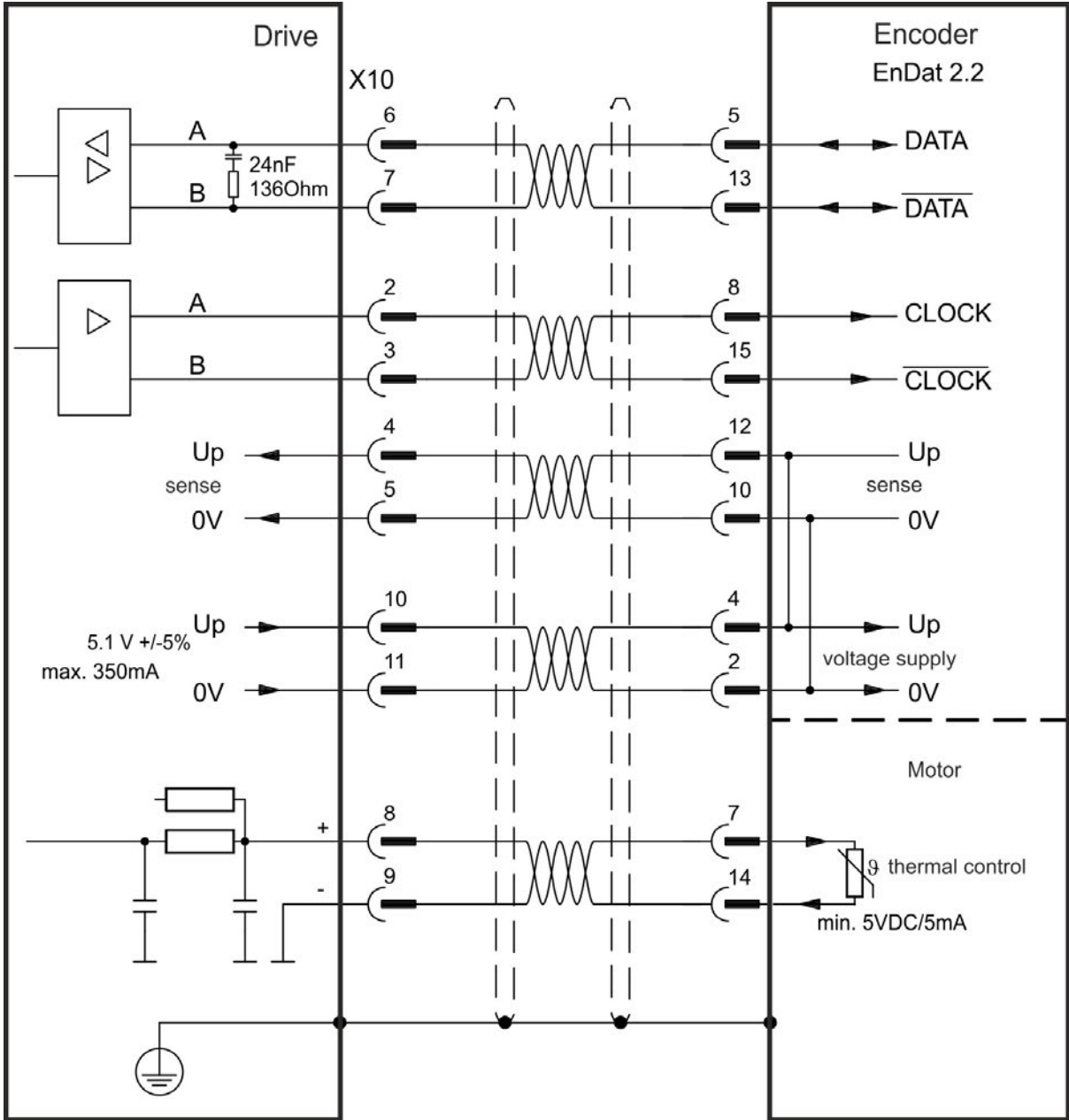

8.12.10.2 Connection to X9 and X8

The thermal control in the motor is connected via Analog I/O on X8 and evaluated in the drive. All signals are connected using our special connection cable (Europe: CFD5).

NOTE

Analog I/O functionality must be selected in the related WorkBench screen. If the set limit is exceeded, then warning n256 is created.

If cable lengths of more than 50 m are planned, please consult customer support.

Type	FB3.MODE	Frequency Limit	Description
ENDAT 2.2	0*	1 MHz	Adjust on screen page FEEDBACK

* For use as primary motor feedback, set parameters DRV.EMUEMODE, PL.FBSOURCE, IL.FBSOURCE, VL.FBSOURCE.

The pin assignment shown on the encoder end relates to Kollmorgen motors.

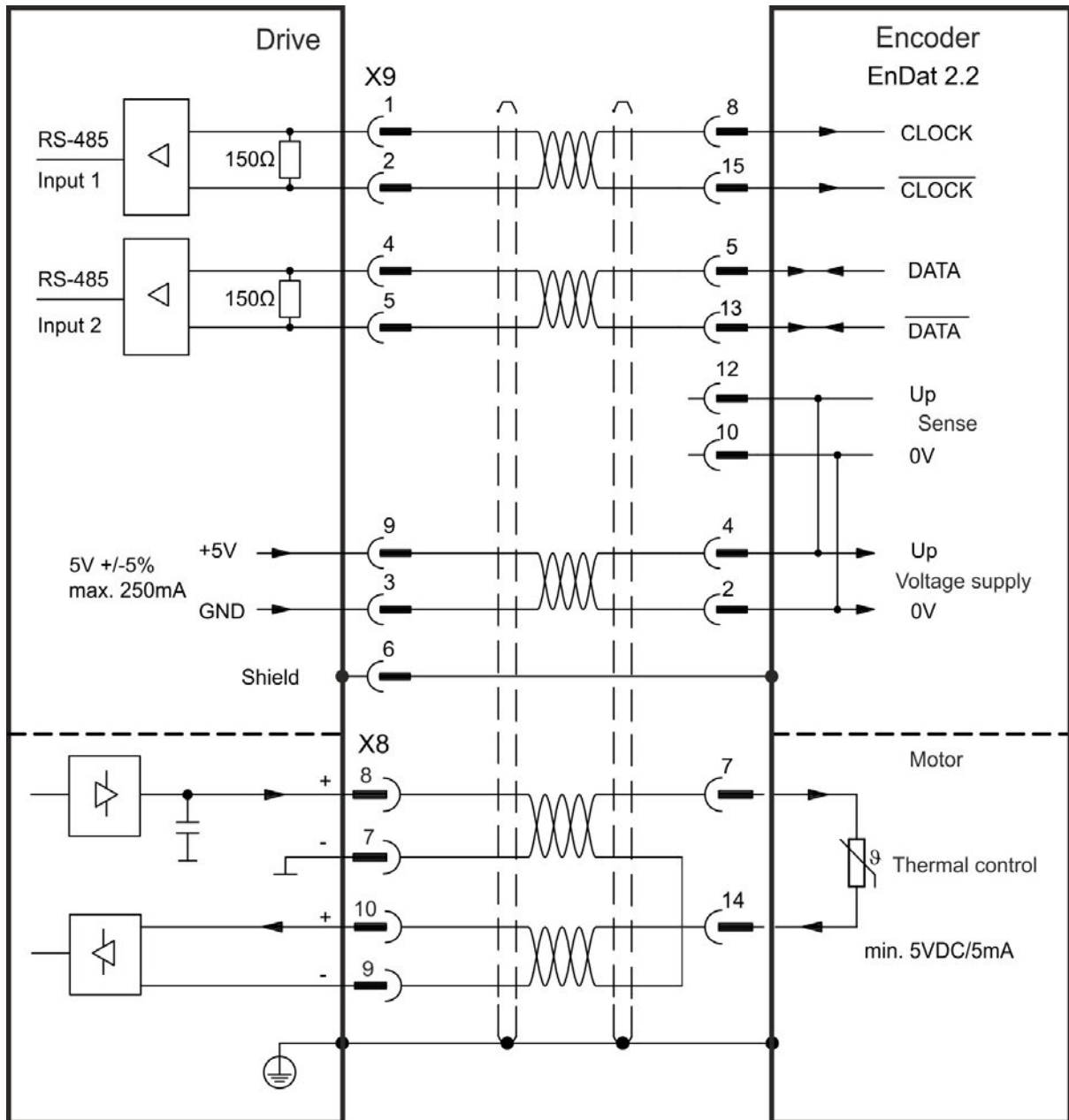

8.12.11 Sine Encoder with Hiperface

The diagram below shows the wiring of a single-turn or multi-turn sine-cosine encoder with Hiperface interface as a feedback system.

The thermal control in the motor is connected via the encoder cable and evaluated in the drive. All signals are connected using our pre-assembled encoder connection cable.

If cable lengths of more than 50 m are planned, please consult customer support.

Type	FBTYP	Frequency Limit	Description
Hiperface	33	1 MHz, 250 kHz for encoders that require termination resistors	Connecting pin 4 and 5 together causes Up to be 8 to 9 V

The pin assignment shown on the encoder end relates to Kollmorgen motors.

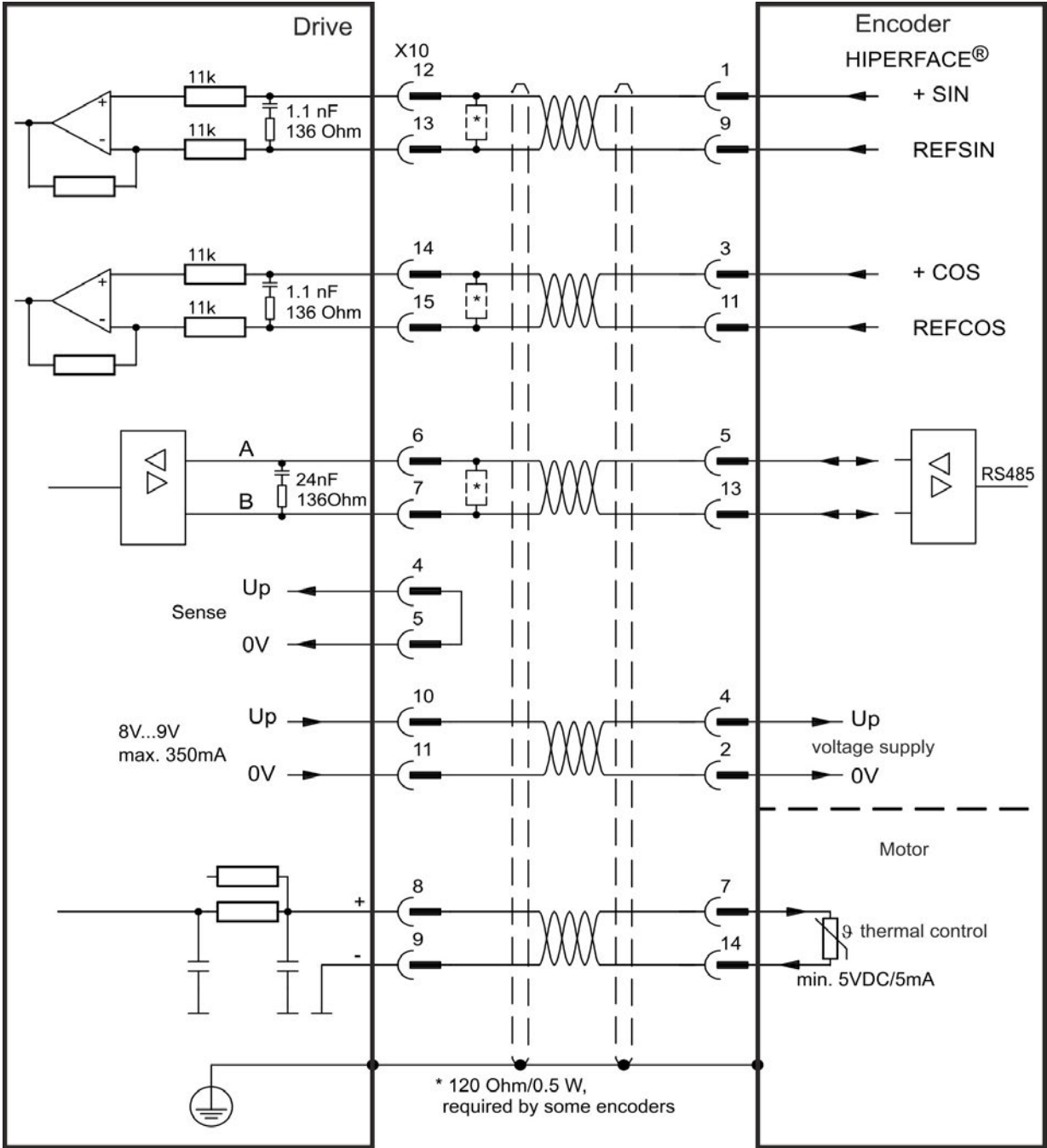

8.12.12 Sine Encoder

Feedback devices, which do not deliver absolute information for commutation, can either work with wake&shake commutation (*WorkBench Online Help*) or can be used as a complete feedback system when combined with an additional Hall encoder. All signals are connected to X10 and evaluated there. If cable lengths of more than 25 m are planned, please consult customer support.

Type	FBTYP E	Up	Frequency Limit
SinCos 1 V p-p with Hall	20	5.1 V +/-5%	1 MHz, 250 kHz for encoders that require termination resistors
SinCos 1 V p-p (Wake&Shake)	21	5.1 V +/-5%	

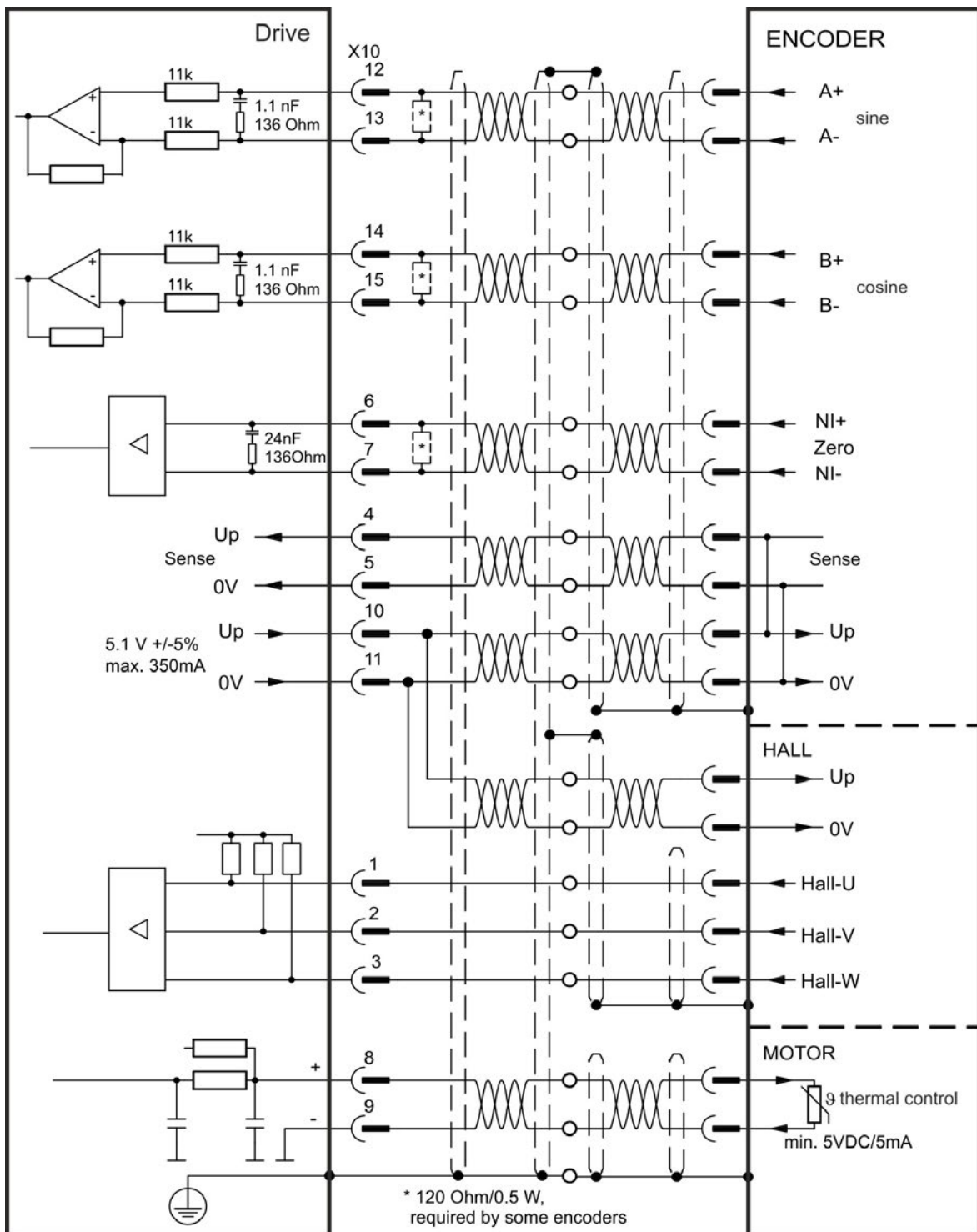

8.12.13 Incremental Encoder

Feedback devices, which do not deliver absolute information for commutation, can either work with wake&shake commutation (see *WorkBench Online Help*) or can be used as a complete feedback system when combined with an additional Hall encoder. All signals are connected using a pre-assembled comcoder connection cable. The thermal control in the motor is connected via the encoder cable and evaluated in the drive.

If cable lengths of more than 25 m are planned, please consult customer support.

Type	FBTYP	Frequency Limit
Incremental Encoder&Hall Switches (Comcoder)	10	2.5 MHz
Incremental Encoder (Wake&Shake)	11	2.5 MHz

The pin assignment shown on the encoder end relates to Kollmorgen AKM motors.

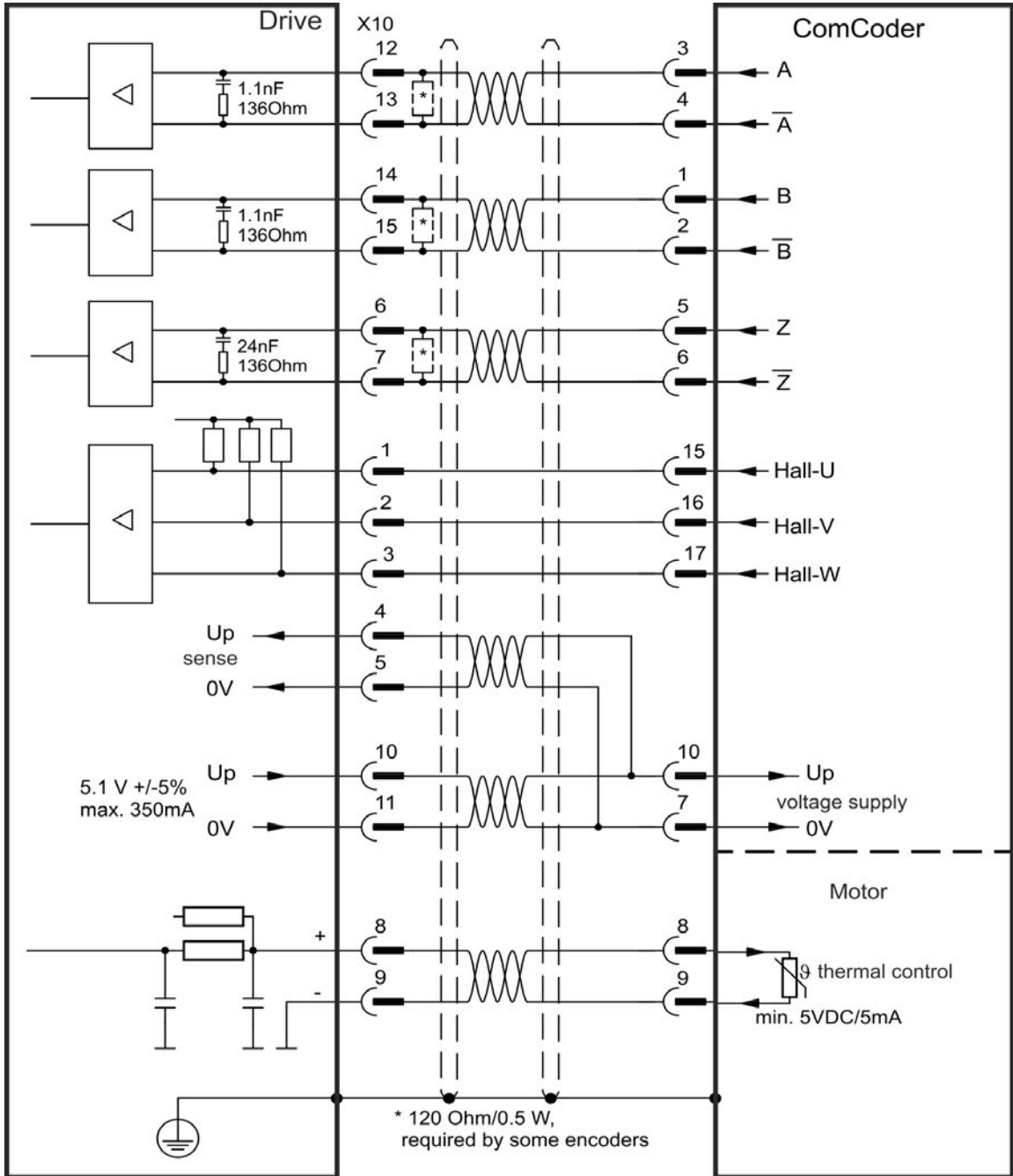

8.12.14 Hall Sensors

This feedback type only supports operating in Torque mode and Velocity mode.

The Hall signals are connected to X10. If cable lengths of more than 25 m are planned, please consult customer support.

NOTE

For more information concerning Hall feedback setting refer to WorkBench Online Help.

Type	FBTYP	Up	Frequency Limit
Hall Only	12	5,1 V +/-5 %	1 MHz

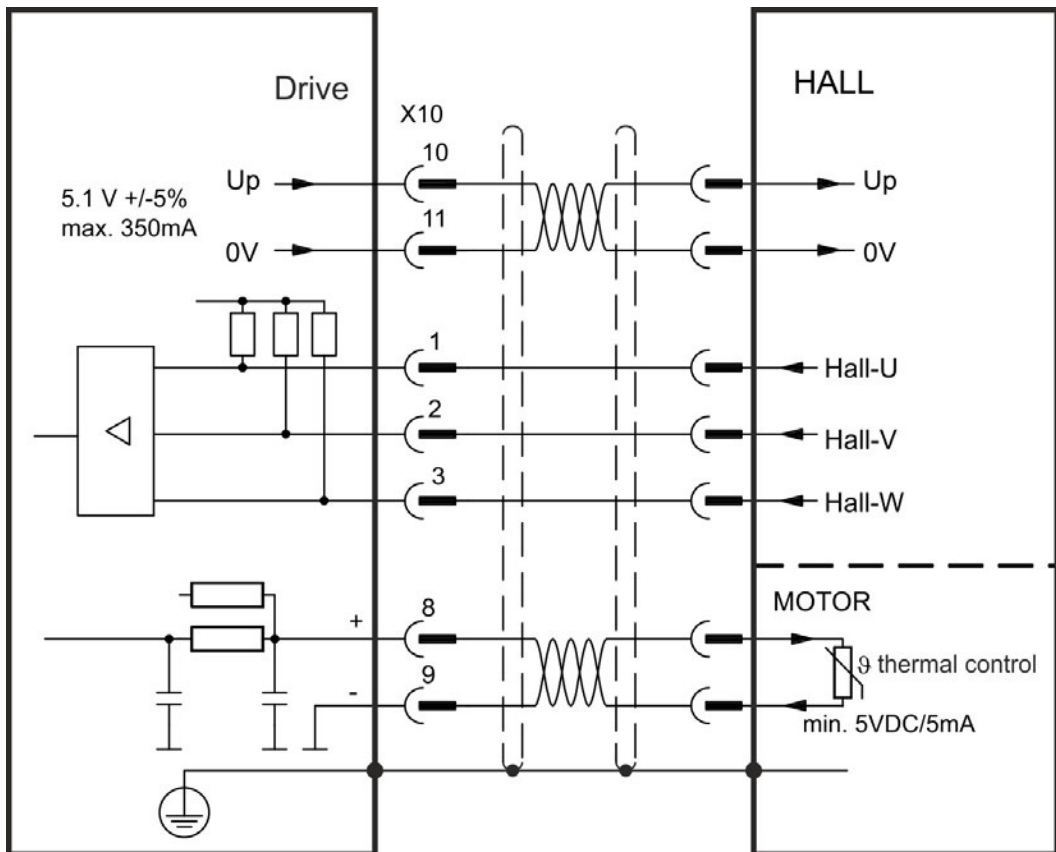

Logic for Kollmorgen motor connection:

AKD		KBM(S)		TBM(S)		VLM(H)		IC, ICH, IL, ID		
Pin	Signal	Color	Name	Color	Name	Color	Name	Color	Pin	Name
X2/4	U	Blue	U	Red	A	Red	U	Red	1	A
X2/5	V	Brown	V	White	B	White	V	White	2	B
X2/6	W	Violet	W	Black	C	Black	W	Black	3	C
X10/1	Hall U	Yellow	H3	Yellow	H-CA	Green	Hall U	Brown	SubD9/4	S3
X10/2	Hall V	Brown	H1	Brown	H-AB	Brown	Hall V	Green	SubD9/2	S1
X10/3	Hall W	Orange	H2	Orange	H-BC	White	Hall W	Yellow	SubD9/3	S2

8.12.15 Tamagawa Smart Abs Encoder

The diagram below shows the wiring of Tamagawa "Smart Abs" encoders (Tamagawa Seiki Co. Ltd. S48-17/33bit-LPS-5V or similar) as a primary feedback system for AKD with "NB" (rev 8+) control board. The thermal control in the motor is connected via the encoder cable and evaluated in the drive. If no thermal control is in the motor, the cable must short pins 8 and 9. The "Sense" signal is optional, and can be omitted if the encoder cable is short and no significant voltage drop is on the cable. The voltage drop depends on the cable length and gage and the encoder current consumption.

If cable lengths of more than 25 m are planned, please consult customer support.

Type	FBTYP	Up	Frequency Limit
S48-17/33bit-LPS-5V	42	5.1 V +/-5%	2.5 MHz

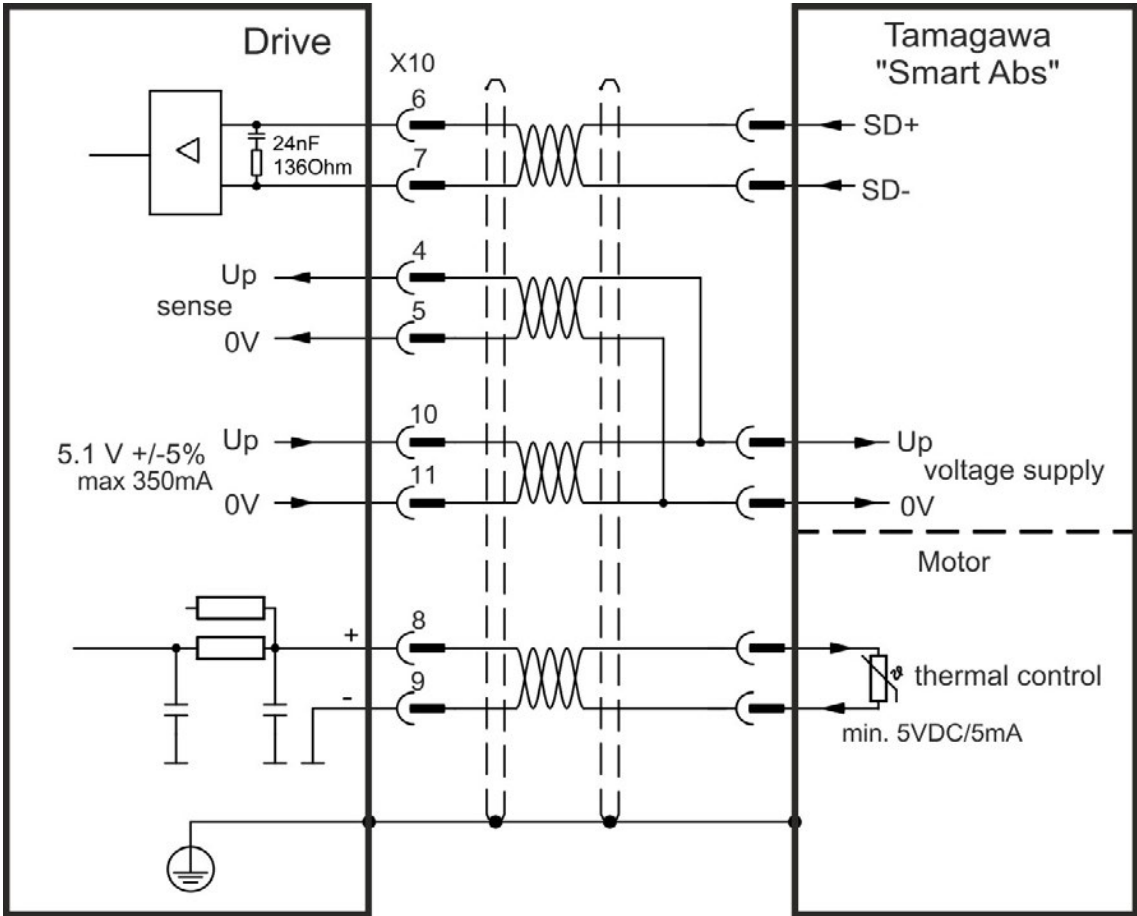

8.13 Electronic gearing, Master-slave operation (X9, X7)

It is possible to set up master/slave systems, use an external encoder as a command encoder, secondary feedback device (dual loop control) or connect the amplifier to a third party step controller. Depending on the signal voltage level connector X9 (5 V TTL) or X7 (24 V) must be used.

The WorkBench setup software is used for configuration. See the “Feedback 2” screen in WorkBench for setup. FB2.SOURCE, FB2.MODE, FB2.ENCRESES and others are used for setting up an application with these interfaces.

Connector X9 can be configured as an input or as an output for 5 V (TTL level) signals.

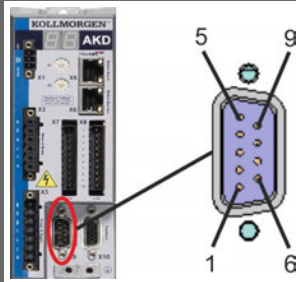
	Input modes X9	Output mode
	Pulse & Direction, 5 V	Emulated Encoder Output (A quad B), 5 V
	CW/CCW, 5 V	
	Incremental Encoder (A quad B), 5 V	
	Encoder with EnDat 2.2, 5 V	

Connector X7, DIGITAL-IN 1/2 can be configured as an input for 24 V signals.

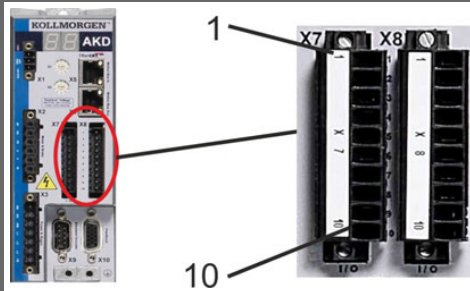
	Input modes X7 DIGITAL-IN 1/2	Output mode
	Pulse & Direction, 24 V	
	CW/CCW, 24 V	
	Incremental Encoder (A quad B), 24 V	

8.13.1 Technical characteristics and pinout

8.13.1.1 Connector X7 Input

Technical characteristics

- Floating, reference common line is DCOM7
- Maximum signal input frequency: 500 kHz
- Sink or Source type connection possible
- High: 15 to 30 V/2 to 15 mA , Low: -3 to 5 V/<15 mA
- Update rate: Hardware 2 μs

Pin	Pulse/Direction	CW/CCW	Incremental Encoder
9	Pulse	CW	Channel A
10	Direction	CCW	Channel B
1	Common	Common	Common

8.13.1.2 Connector X9 Input

Technical characteristics

- Electrical interface: RS-485
- Maximum signal input frequency: 3MHz
- Input signal voltage range: +12 V to -7 V
- Supply voltage (only applicable to Incremental Encoder Input): +5 V \pm 5%
- Maximum supply current: 250 mA

Pin	Pulse/Direction	CW/CCW	Incremental Encoder	Encoder with EnDat 2.2
1	Pulse+	CW+	A+	CLOCK+
2	Pulse-	CW-	A-	CLOCK-
3	GND	GND	GND	GND
4	Direction+	CCW+	B+	DATA+
5	Direction-	CCW-	B-	DATA-
6	Shield	Shield	Shield	Shield
7	-	-	Zero+	-
8	-	-	Zero-	-
9	-	-	+ 5 V (supply, output)	+5V (supply, output)

NOTICE

Maximum cable length of an external incremental encoder using X9 is dependant on cable voltage drop and external encoder power requirements. See the calculation example in the *WorkBench Online Help* chapter "Electronic Gearing".

8.13.1.3 Connector X9 Output

Technical characteristics

- Electrical Interface: RS-485
- Max signal (channel) output frequency: 3 MHz
- The pulses per revolution value are settable
- Pulse phase shift: $90^{\circ} \pm 20^{\circ}$

Pin	Emulated Encoder Output
1	Channel A+
2	Channel A-
3	GND
4	Channel B+
5	Channel B-
6	Shield
7	Channel Zero+
8	Channel Zero-
9	-

NOTE

The maximum permissible cable length is 100 meters.

8.13.2 Command encoder signal connection

8.13.2.1 Incremental encoder input 5 V (X9)

A 5 V A quad B encoder, or the encoder emulation output of another drive can be connected to this input and used as a commander encoder, dual loop feedback, gearing or camming input. Parameter setting FB2.MODE = 0, FB2.SOURCE=1.

NOTE

Don't use for primary motor feedback connection!

Connection Diagram

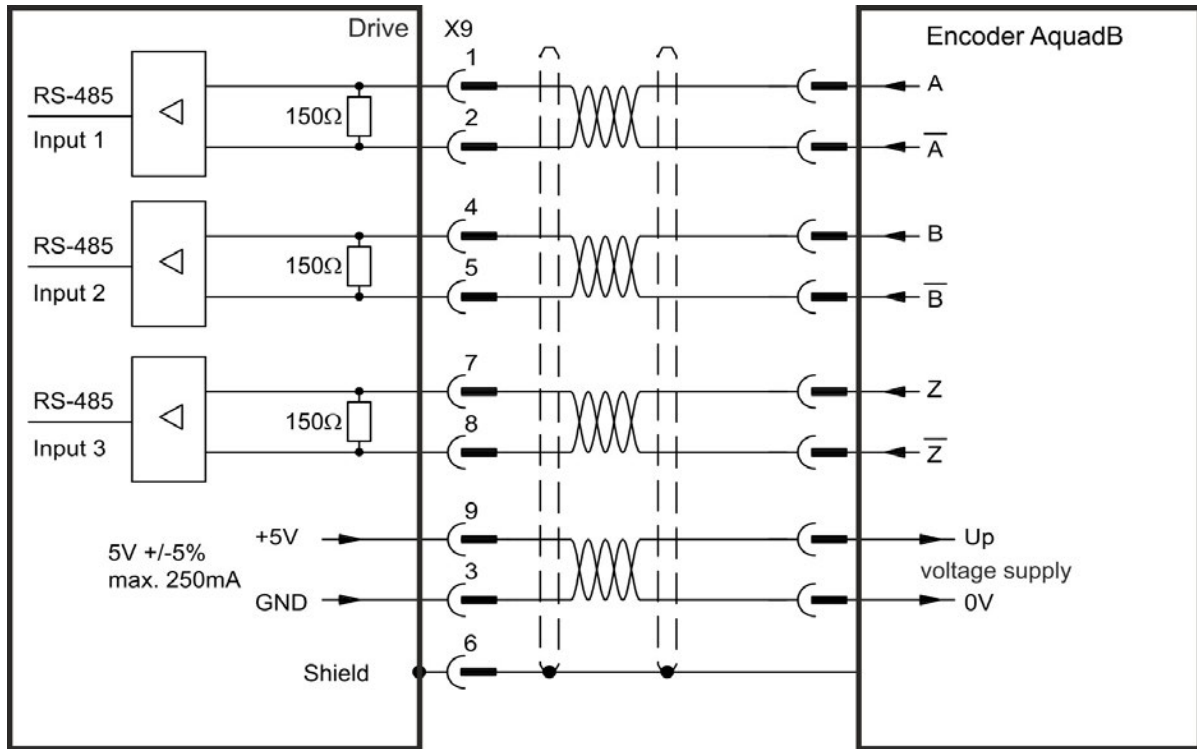

8.13.2.2 Incremental encoder input 24 V (X7)

A 24 V A quad B encoder can be connected to the digital inputs 1 and 2 and used as a commander encoder, dual loop feedback, gearing or camming input. Parameter setting FB2.MODE = 0, FB2.SOURCE=2.

NOTE

Don't use for primary motor feedback connection!

Connection Diagram

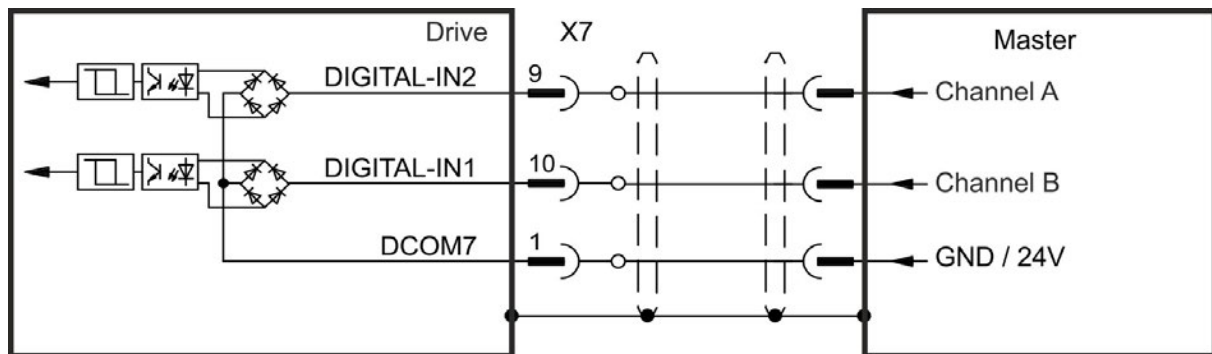

8.13.2.3 Encoder with EnDat 2.2 input 5 V (X9)

A single-turn or multi-turn encoder with EnDat 2.2 can be connected to this input and used as a commander encoder, dual loop feedback, gearing or camming input. Parameter setting FB3.MODE=0, DRV.EMUEMODE=11.

NOTE

Can be used as primary motor feedback connection (→ # 130)!

Connection Diagram

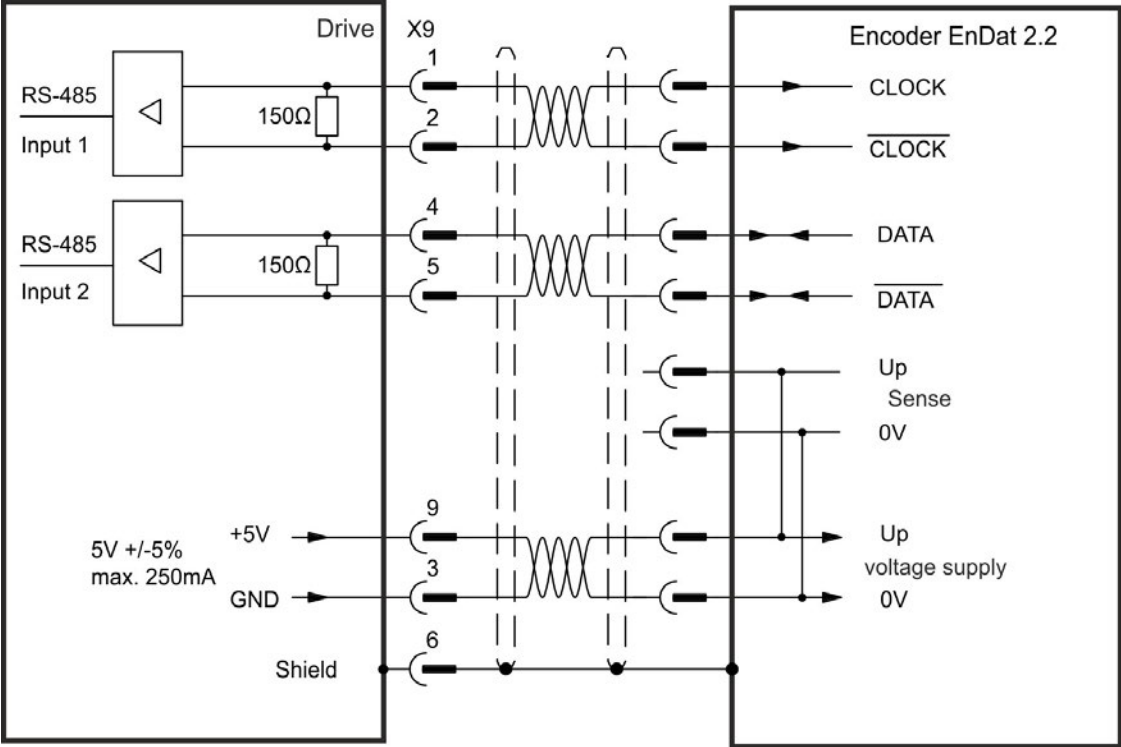

8.13.3 Pulse / Direction signal connection

The drive can be connected to a stepper-motor controller. Set parameters for the drive with WorkBench. The number of pulses can be adjusted, so that the drive can be adapted to match any stepper controller.

Speed profile and signal diagram

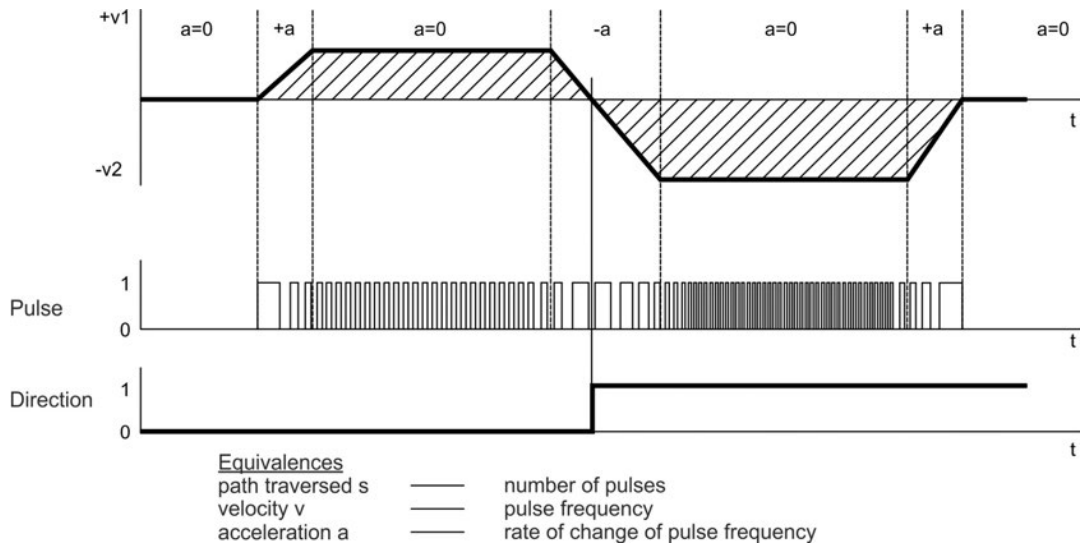

8.13.3.1 Pulse / Direction input 5 V (X9)

Connection to 5 V signal level stepper-motor controllers.

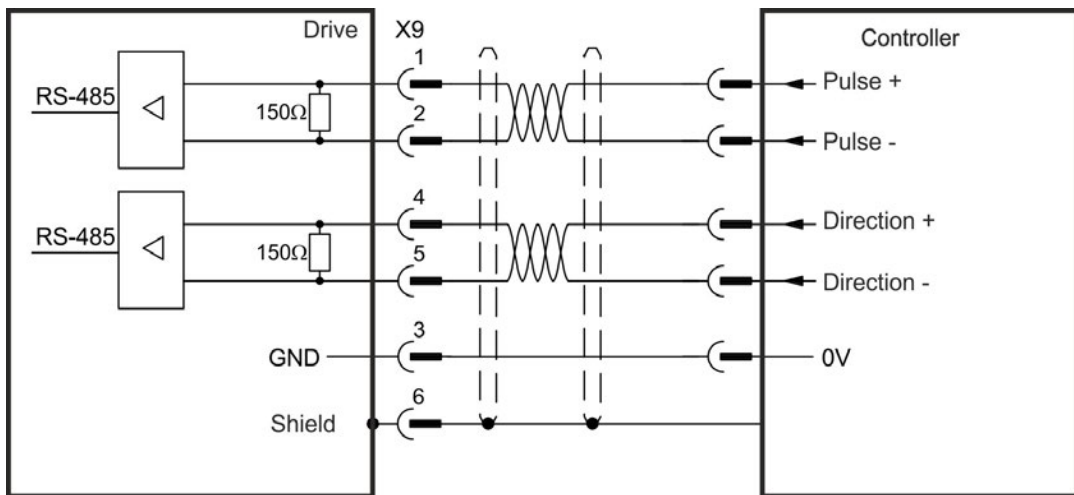

8.13.3.2 Pulse / Direction Input 5 V to 24 V (X7)

Connection industry standard 5V logic stepper-motor controllers with Pulse/Direction or Step/Direction outputs. Note that the X7 opto inputs can work with 5V up to 24V logic and so these inputs can be driven by 24V logic inputs as well.

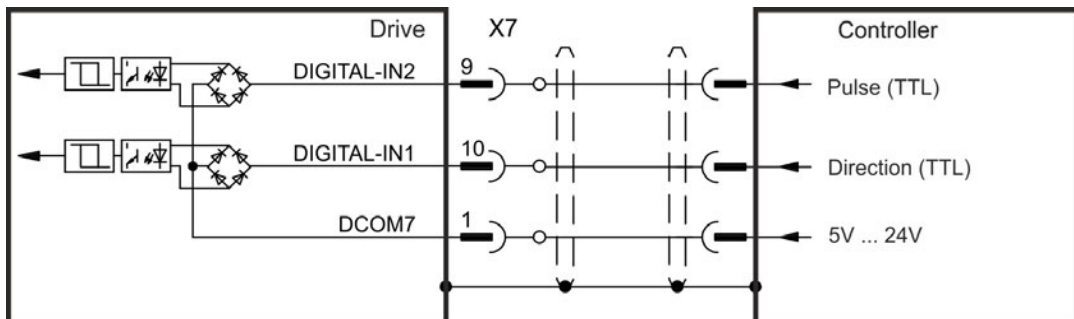

8.13.4 CW / CCW signal connection

8.13.4.1 CW / CCW input 5 V (X9)

The drive can be connected to a third-party controller which delivers 5 V CW/CCW signals

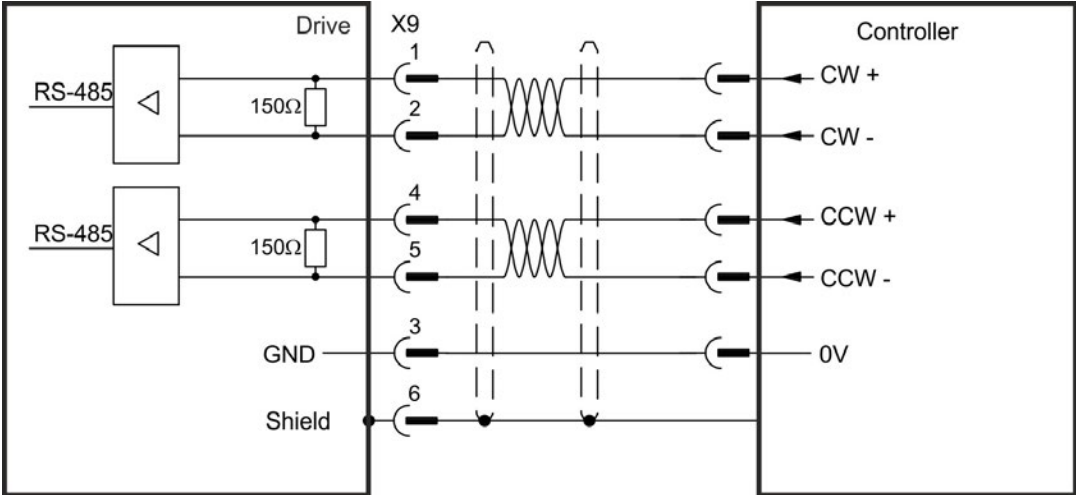

8.13.4.2 CW / CCW input 24 V (X7)

The drive can be connected to a third-party controller which delivers 24 V CW/CCW signals.

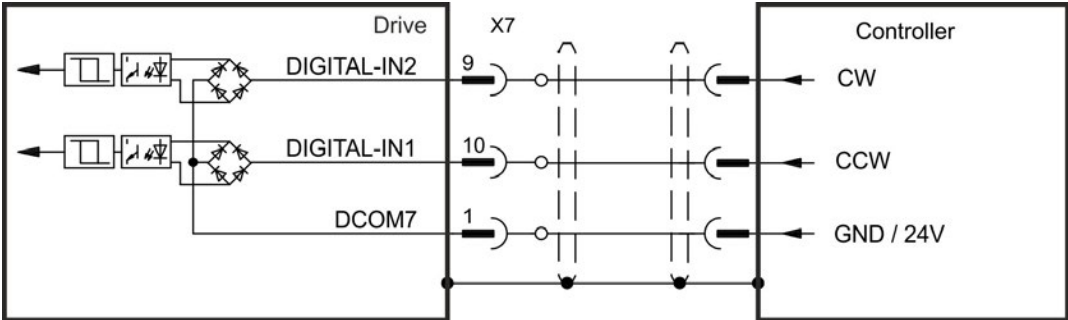

8.13.5 Emulated Encoder Output (EEO)

The drive calculates the motor shaft position from the cyclic- absolute signals of the primary feedback, generating incremental-encoder compatible pulses from this information. Pulse outputs on the SubD connector X9 are 3 signals, A, B and Index, with 90° phase difference (i.e. in quadrature, hence the alternative term “A quad B” output), with a zero pulse.

The resolution (before multiplication) can be set by the DRV.EMUERES parameter. Use the DRV.EMUEZOFFSET parameter to adjust + save the zero pulse position within one mechanical turn. The drivers operate from an internal supply voltage.

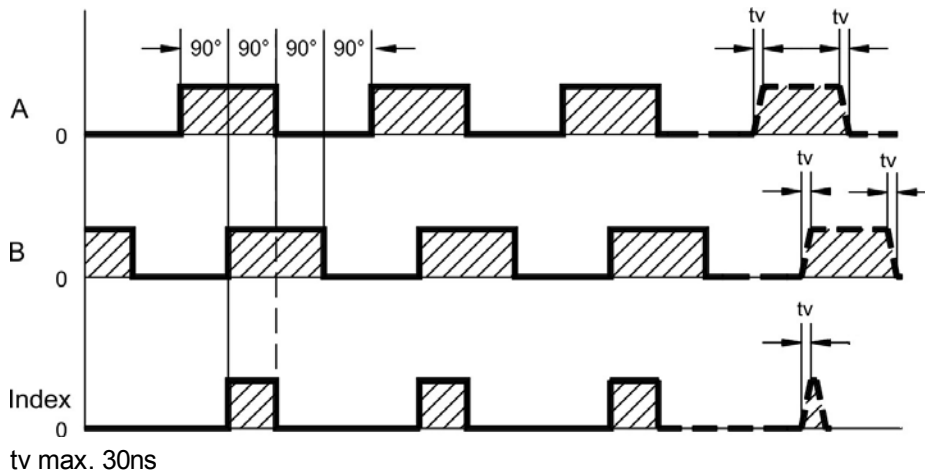

Connection Diagram

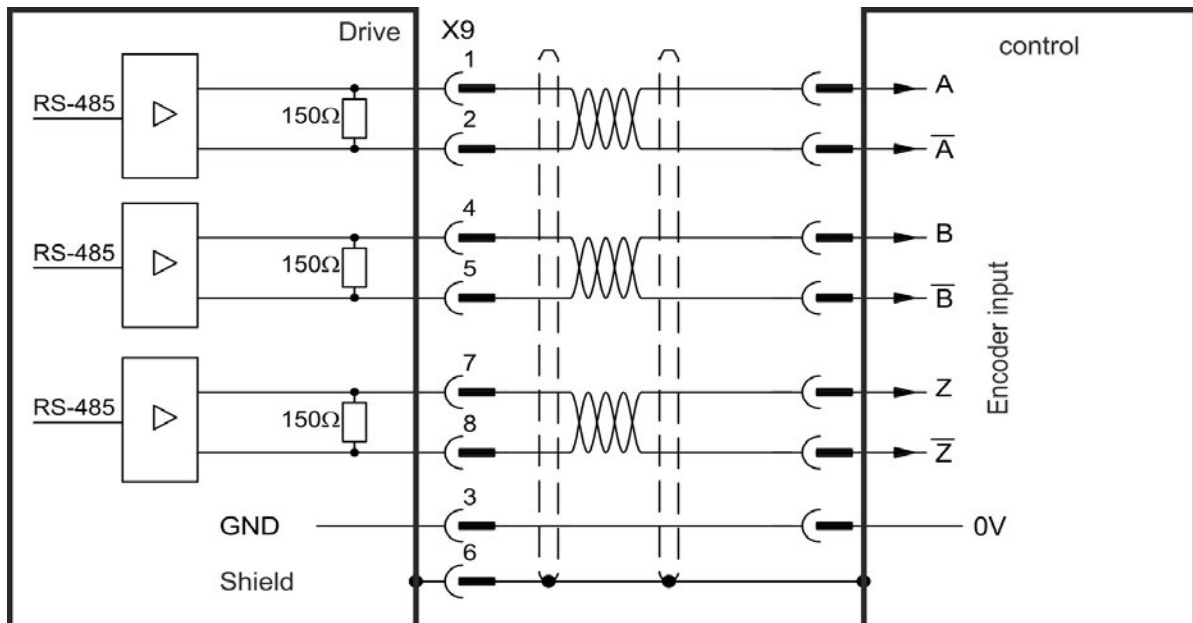

8.13.6 Master-Slave control

Several AKD can be connected as slave drives to an AKD master. The slave drives use the master's encoder output signals as command input and follow these commands (velocity and direction).

Master-Slave Connection Diagram, example for 5V signal level (X9)

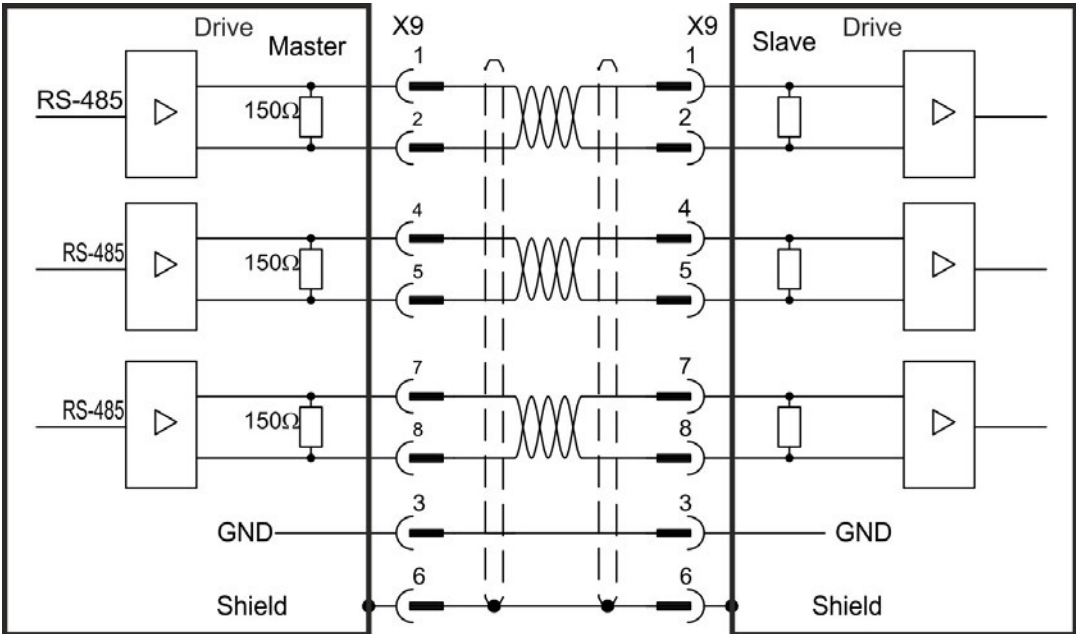

8.14 I/O Connection

8.14.1 Overview

8.14.1.1 I/O connectors X7 and X8 (all AKD variants)

Standard digital and analog I/O signals are connected to X7 and X8.

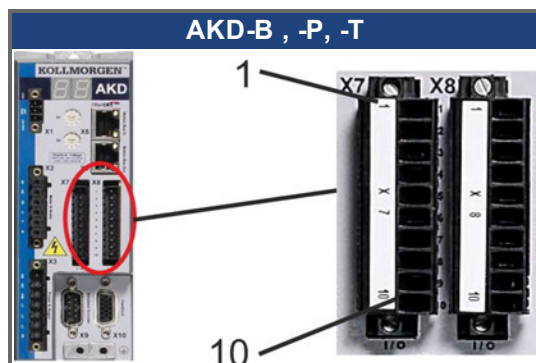

Conn.	Pin	Signal	Abbreviation	Function	Wiring Diagram
X7	1	Digital Common X7	DCOM7	Common line for X7 pins 2, 3, 4, 9, 10	(→ # 150)
X7	2	Digital Input 7	DIGITAL-IN 7	Programmable	
X7	3	Digital Input 4	DIGITAL-IN 4	Programmable	
X7	4	Digital Input 3	DIGITAL-IN 3	Programmable	
X7	5	Digital Output 2-	DIGITAL-OUT2-	Programmable	
X7	6	Digital Output 2+	DIGITAL-OUT2+	Programmable	
X7	7	Digital Output 1-	DIGITAL-OUT1-	Programmable	
X7	8	Digital Output 1+	DIGITAL-OUT1+	Programmable	
X7	9	Digital Input 2	DIGITAL-IN 2	Programmable,fast	
X7	10	Digital Input 1	DIGITAL-IN 1	Programmable,fast	
X8	1	Fault Relay Output	Fault Relay Output	Fault Relay Output	(→ # 158)
X8	2	Fault Relay Output	Fault Relay Output	Fault Relay Output	
X8	3	Digital Common X8	DCOM8	Common line for X8 pins 4, 5, 6	(→ # 150)
X8	4	Digital Input 8	DIGITAL-IN 8	Output stage enable, not programmable	
X8	5	Digital Input 6	DIGITAL-IN 6	Programmable	
X8	6	Digital Input 5	DIGITAL-IN 5	Programmable	
X8	7	Analog Ground	AGND	Analog GND	(→ # 149)
X8	8	Analog Output +	Analog-Out	Actual velocity voltage	(→ # 148)
X8	9	Analog Input -	Analog-In-	Velocity set point	
X8	10	Analog Input +	Analog-In+		

Digital common lines for X7 and X8 are not common to each other.

The DCOMx line should be connected to the 0V of the I/O supply when using sensors of type "Source" with digital inputs.

The DCOMx line should be connected to the 24V of the I/O supply when using sensors of type "Sink" with digital inputs.

8.14.1.2 I/O connectors X21, X22, X23 and X24 (AKD-T with I/O option card only)

The I/O option card offers four additional connectors X21, X22, X23, X24 for I/O signals.

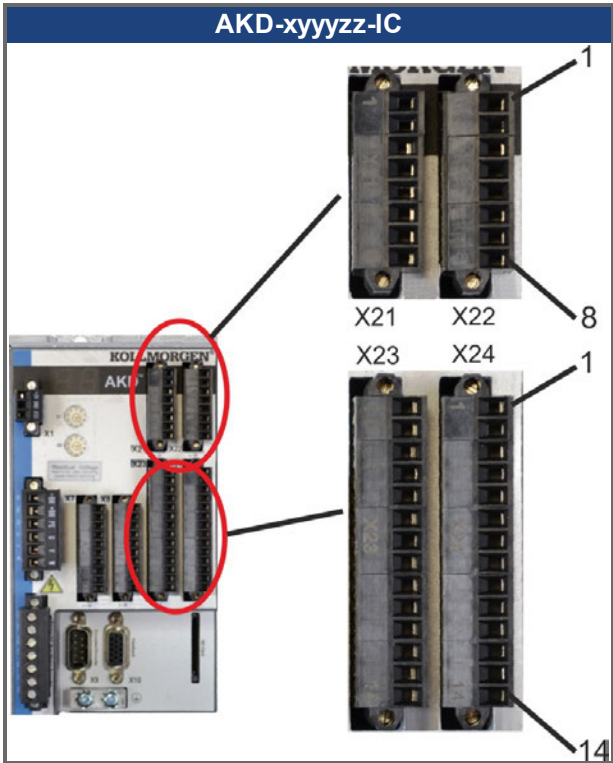

Conn.	Pin	Signal	Abbreviation	Function	Wiring Diagram
X21	1	Digital Input 21	DIGITAL-IN 21	Programmable	(→ # 153)
X21	2	Digital Input 22	DIGITAL-IN 22	Programmable	
X21	3	Digital Input 23	DIGITAL-IN 23	Programmable	
X21	4	Digital Common X21/1_3	DCOM21.1_3	Common line for X21 pins 1, 2, 3	
X21	5	Digital Input 24	DIGITAL-IN 24	Programmable	
X21	6	Digital Input 25	DIGITAL-IN 25	Programmable	
X21	7	Digital Input 26	DIGITAL-IN 26	Programmable	
X21	8	Digital Common X21/5_7	DCOM21.5_7	Common line for X21 pins 5, 6, 7	
X22	1	Digital Input 27	DIGITAL-IN 27	Programmable	(→ # 153)
X22	2	Digital Input 28	DIGITAL-IN 28	Programmable	
X22	3	Digital Input 29	DIGITAL-IN 29	Programmable	
X22	4	Digital Common X22/1_3	DCOM22.1_3	Common line for X22 pins 1, 2, 3	
X22	5	Digital Input 30	DIGITAL-IN 30	Programmable	
X22	6	Digital Input 31	DIGITAL-IN 31	Programmable	
X22	7	Digital Input 32	DIGITAL-IN 32	Programmable	
X22	8	Digital Common X22/5_7	DCOM22.5_7	Common line for X22 pins 5, 6, 7	

Conn.	Pin	Signal	Abbreviation	Function	Wiring Diagram
X23	1	Analog Output 2 +	Analog-Out2	Programmable	(→ # 149)
X23	2	reserved	n.c.	n.c.	
X23	3	Analog Ground	AGND	Programmable	
X23	4	reserved	n.c.	n.c.	
X23	5	Digital Output 21+	DIGITAL-OUT 21+	Programmable	(→ # 159)
X23	6	Digital Output 21-	DIGITAL-OUT 21-	Programmable	
X23	7	Digital Output 22+	DIGITAL-OUT 22+	Programmable	
X23	8	Digital Output 22-	DIGITAL-OUT 22-	Programmable	
X23	9	Digital Output 23+	DIGITAL-OUT 23+	Programmable	
X23	10	Digital Output 23-	DIGITAL-OUT 23-	Programmable	
X23	11	Digital Output 24+	DIGITAL-OUT 24+	Programmable	
X23	12	Digital Output 24-	DIGITAL-OUT 24-	Programmable	
X23	13	Relay Output 25	DIGITAL-OUT 25	Programmable, relay	(→ # 160)
X23	14	Relay Output 25	DIGITAL-OUT 25	Programmable, relay	
X24	1	Analog Input 2+	Analog-In2+	Programmable	(→ # 148)
X24	2	Analog Input 2-	Analog-In2-	Programmable	
X24	3	Analog Ground	AGND	Programmable	
X24	4	reserved	n.c.	n.c.	
X24	5	Digital Output 26+	DIGITAL-OUT 26+	Programmable	(→ # 159)
X24	6	Digital Output 26-	DIGITAL-OUT 26-	Programmable	
X24	7	Digital Output 27+	DIGITAL-OUT 27+	Programmable	
X24	8	Digital Output 27-	DIGITAL-OUT 27-	Programmable	
X24	9	Digital Output 28+	DIGITAL-OUT 28+	Programmable	
X24	10	Digital Output 28-	DIGITAL-OUT 28-	Programmable	
X24	11	Digital Output 29+	DIGITAL-OUT 29+	Programmable	
X24	12	Digital Output 29-	DIGITAL-OUT 29-	Programmable	
X24	13	Relay Output 30	DIGITAL-OUT 30	Programmable, relay	(→ # 160)
X24	14	Relay Output 30	DIGITAL-OUT 30	Programmable, relay	

8.14.1.3 I/O connectors X35 and X36 (AKD-M only)

AKD PDMM offers two additional connectors X35 and X36 for digital I/O signals.

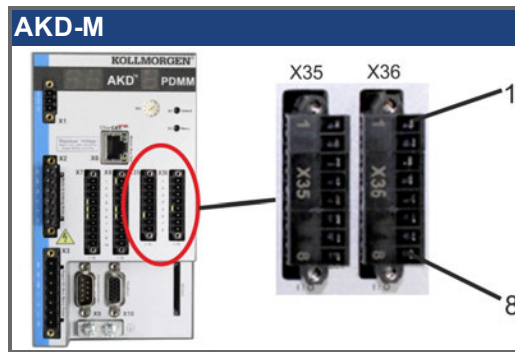

Conn.	Pin	Signal	Abbreviation	Function	Wiring Diagram
X35	1	Digital Common X35	DCOM35	Common line for X35 pins 2, 3, 4	(→ # 155)
X35	2	Digital Input 21	DIGITAL-IN 21	Programmable	
X35	3	Digital Input 22	DIGITAL-IN 22	Programmable	
X35	4	Digital Input 23	DIGITAL-IN 23	Programmable	
X35	5	n.c.	n.c.	-	-
X35	6	n.c.	n.c.	-	-
X35	7	Digital Output 21-	DIGITAL-OUT21-	Programmable	(→ # 161)
X35	8	Digital Output 21+	DIGITAL-OUT21+	Programmable	
X36	1	Digital Common X36	DCOM36	Common line for X36 pins 2, 3, 4	(→ # 155)
X36	2	Digital Input 24	DIGITAL-IN 24	Programmable	
X36	3	Digital Input 25	DIGITAL-IN 25	Programmable	
X36	4	Digital Input 26	DIGITAL-IN 26	Programmable	
X36	5	n.c.	n.c.	-	-
X36	6	n.c.	n.c.	-	-
X36	7	Digital Output 22-	DIGITAL-OUT22-	Programmable	(→ # 161)
X36	8	Digital Output 22+	DIGITAL-OUT22+	Programmable	

Digital common lines for X35 and X36 are not common to each other.

The DCOMx line should be connected to the 0V of the I/O supply when using sensors of type "Source" with digital inputs.

The DCOMx line should be connected to the 24V of the I/O supply when using sensors of type "Sink" with digital inputs.

8.14.2 Analog Input (X8, X24)

The drive is fitted with differential inputs for analog torque, velocity, or position control. The standard drive offers one analog input on X8, drives with built-in I/O option card offer a second input on X24.

Technical characteristics

- Differential input voltage range: ± 12.5 V
- Maximum input voltage referring to I/O Return: -12.5, +16.0 V
- Resolution: 16 Bit and fully monotonic
- Firmware update rate: 16 kHz
- Unadjusted offset: < 50 mV
- Offset drift typ: $250 \mu\text{V} / ^\circ\text{C}$
- Gain or slope tolerance: $\pm 3\%$
- Nonlinearity: < 0.1% of full scale or 12.5 mV
- Common Mode Rejection Ratio: > 30 dB at 60 Hz
- Input impedance: > 13k Ohms
- Signal to noise ratio referred to full scale:
 - AIN.CUTOFF = 3000 Hz: 14 bit
 - AIN.CUTOFF = 800 Hz: 16 bit

Analog Input Wiring Diagram

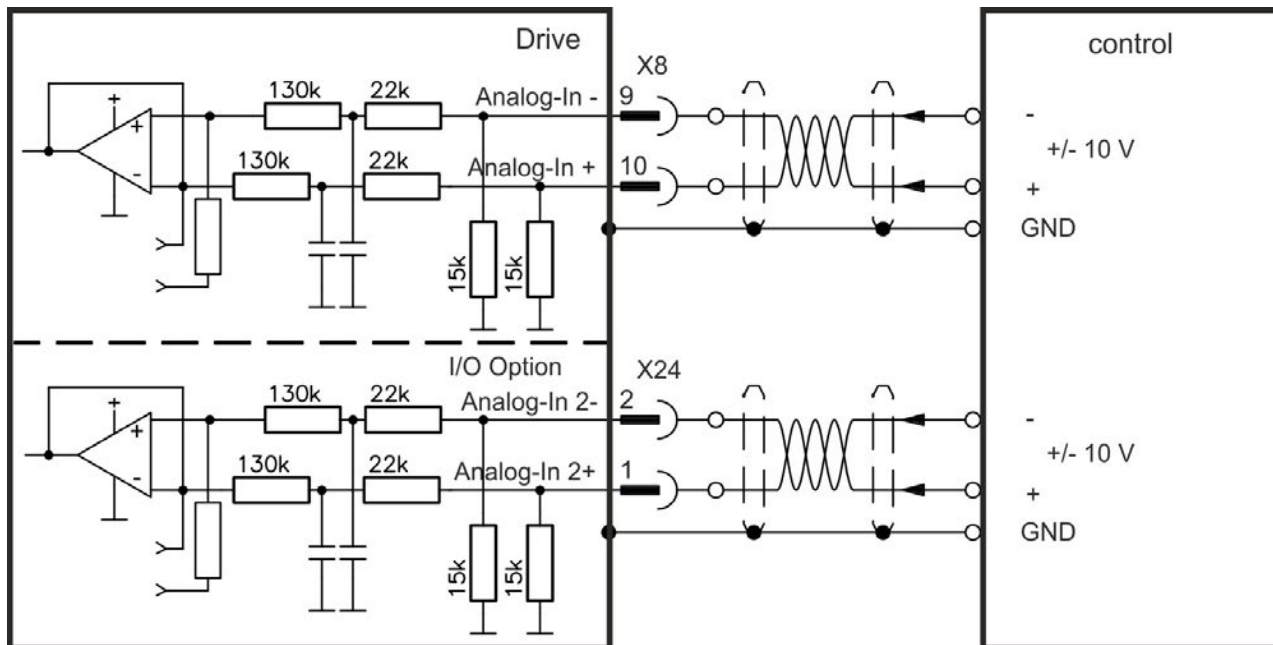

Application examples for set point input Analog-In:

- reduced-sensitivity input for setting-up/jog operation
- pre-control/override

Defining the direction of rotation

Standard setting: clockwise rotation of the motor shaft (looking at the shaft end) affected by positive voltage between terminal (+) and terminal (-)

To reverse the direction of rotation, swap the connections to terminals +/-, or change the DRV.DIR parameter in the "Feedback 1" screen page.

8.14.3 Analog Output (X8, X23)

Analog Outputs can be used to output converted analog values of digital measurements recorded in the drive. The standard drive offers one analog output on X8, drives with built-in I/O option card offer a second output on X23. A list of the pre-programmed functions is included in the WorkBench setup software.

Technical characteristics

- Output voltage range referring to AGND: $\pm 10\text{ V}$
- Resolution: 16 Bit and fully monotonic
- Update rate: 4 kHz
- Unadjusted offset: $< 50\text{ mV}$
- Offset drift typ: $250\ \mu\text{V}/^\circ\text{C}$
- Gain or slope tolerance: $\pm 3\%$
- Nonlinearity: $< 0.1\%$ of full scale or 10 mV
- Output impedance: $110\ \text{ohms}$
- Specification complies with IEC 61131-2 Table 11
- -3 dB Bandwidth: $> 8\text{ kHz}$
- Maximum output current: 20 mA
- Capacitive load: any value but response speed limited by max Iout and by Rout
- Protected for short circuit to AGND

Analog Output Wiring Diagram

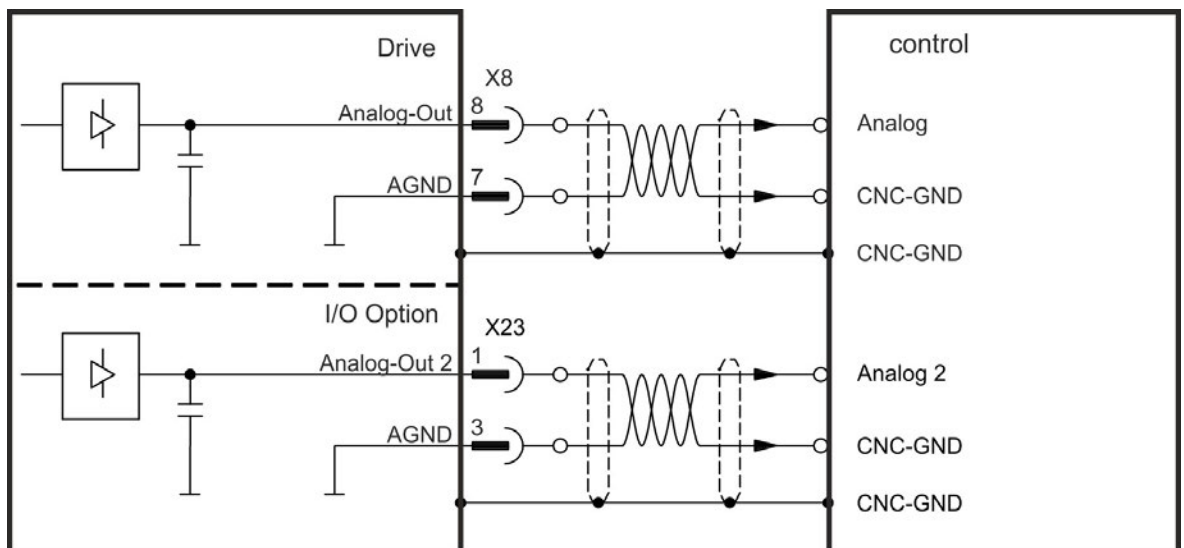

8.14.4 Digital Inputs (X7/X8)

The drive provides 8 digital inputs (→ # 144). These can be used to initiate pre-programmed functions that are stored in the drive. A list of these pre-programmed functions is included in the WorkBench. Digital Input 8 is not programmable but is fixed to the ENABLE function. If an input is programmed, it must be saved to the drive.

NOTE

Depending on the selected function, the inputs are high or low active. Digital input filter can be set in WorkBench to change sensitivity of the inputs (see Online Help).

The inputs can be used with switched +24 V (source type) or switched GND (sink type). See diagrams below for typical examples of digital input wiring.

Digital Input Wiring Diagram (Source type connection, example)

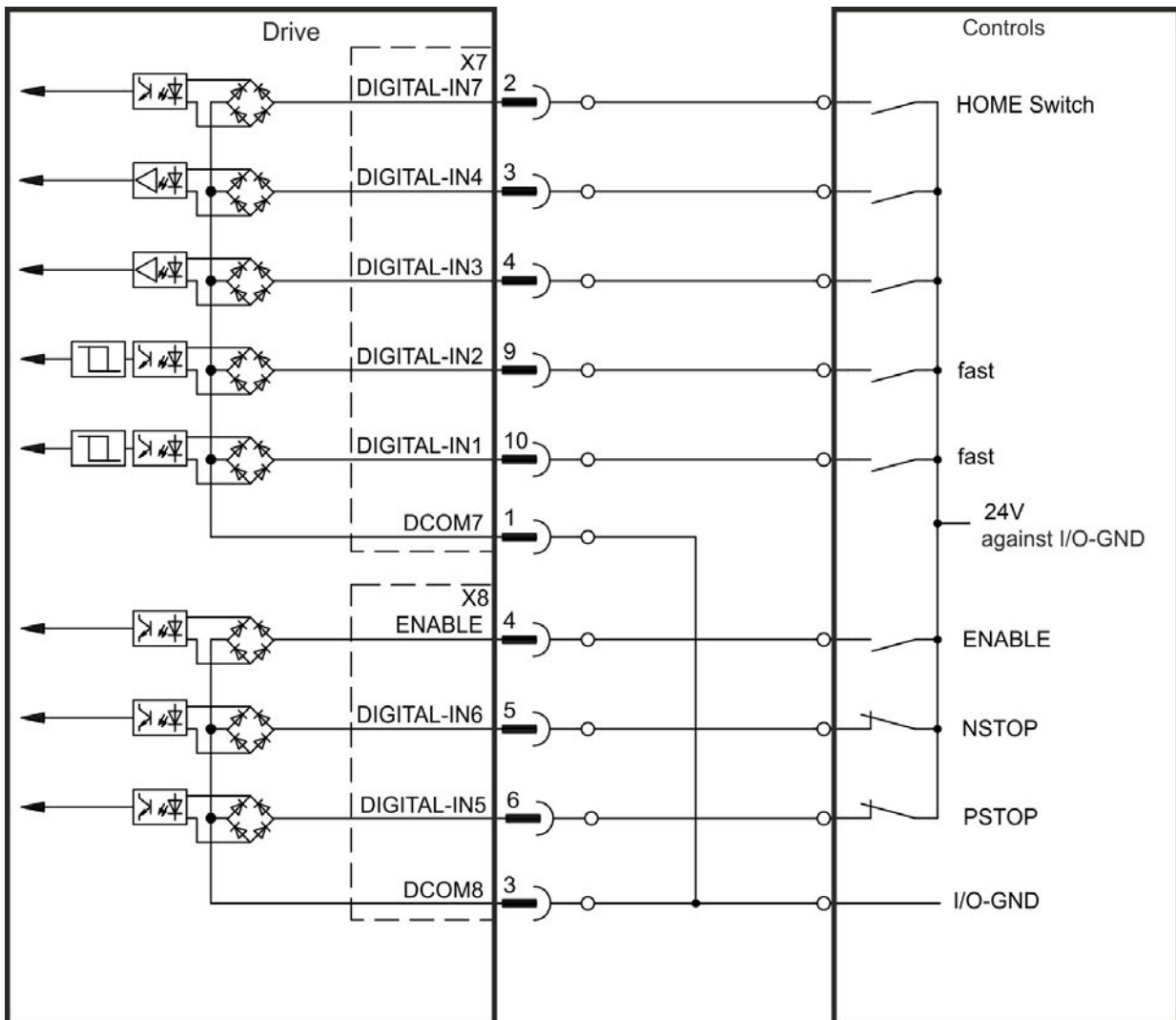

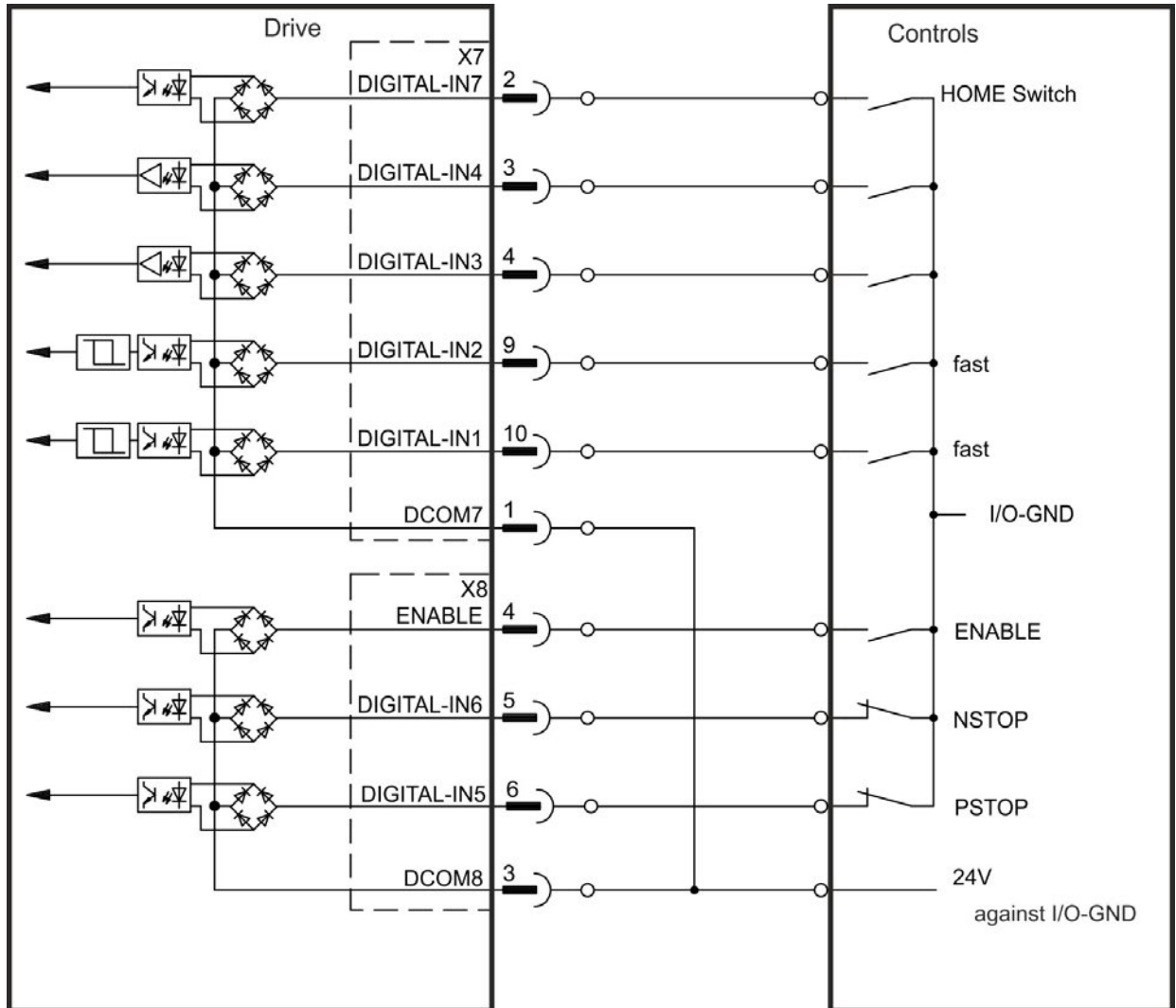
Digital Input Wiring Diagram (Sink type connection, example)

8.14.4.1 Digital Inputs 1 and 2

These inputs (X7/9 and X7/10) are particularly fast and are therefore suitable for position latch functions. They can also be used as 24 V inputs for electronic gearing ((→ # 136)).

Technical characteristics

- Floating, reference common line is DCOM7
- Sink or Source type sensors possible
- High: 3.5 to 30 V/2 to 15 mA , Low: -2 to +2 V/<15 mA
- Update rate: firmware reads hardware input state every 250 μ s
- High accuracy latch: motor feedback position or interpolated time is latched or captured within 2 μ s of input signal transition (with digital input filter set to 40 ns)
- The AKD capture engine is polled every 62.5 μ s (16 kHz) by the firmware
- For KAS applications (example: AKD PDMM), the latch position information is updated in the Ethercat PDO. The typical update time into the KAS project is two Ethercat cycles (with each cycle being 250 μ s, 500 μ s, 1000 μ s, or 2000 μ s)

8.14.4.2 Digital Inputs 3 to 7

These inputs are programmable with the setup software. By default, all inputs are not programmed (off).

For more information refer to the setup software.

Technical characteristics

Choose the function you require in WorkBench.

- Floating, reference common line is DCOM7 or DCOM8
- Sink or Source type sensors possible
- High: 3.5 to 30 V/2 to 15 mA , Low: -2 to +2 V/<15 mA
- Update rate: firmware reads hardware input state every 250 μ s

8.14.4.3 Digital Input 8 (ENABLE)

Digital Input 8 (terminal X8/4) is set to Enable function.

- Floating, reference common line is DCOM8
- Sink or Source type wiring is possible
- High: 3.5 to 30 V/2 to 15 mA , Low: -2 to +2 V/<15 mA
- Update rate: direct connection to hardware (FPGA)

NOTE

The Hardware Enable input and the Software Enable signal (via fieldbus or WorkBench) are serial, that means wiring of Hardware Enable is mandatory.

The output stage of the drive is enabled by applying the ENABLE signal (Terminal X8/4, active high). Enable is possible only if input STO has a 24 V signal ((→ # 53)). In the disabled state (low signal) the connected motor has no torque.

A software enable by means of the setup software is also required (AND link), although this can also be permanently enabled with WorkBench.

8.14.5 Digital Inputs with I/O option (X21, X22)

The drive option "IC" provides 12 additional digital inputs (→ # 144). These can be used to initiate pre-programmed functions that are stored in the drive. A list of these pre-programmed functions is included in WorkBench. If an input is programmed, it must be saved to the drive.

NOTE

Depending on the selected function the inputs are high or low active. The inputs can be used with switched +24 V (source type) or switched GND (sink type).

Technical characteristics

- Floating, sink or source type sensors possible
- High: 3.5 to 30 V/2 to 15 mA , Low: -2 to +2 V/<15 mA, Update rate: Software 250 µs

Digital Input Wiring Diagram (Source type connection, example)

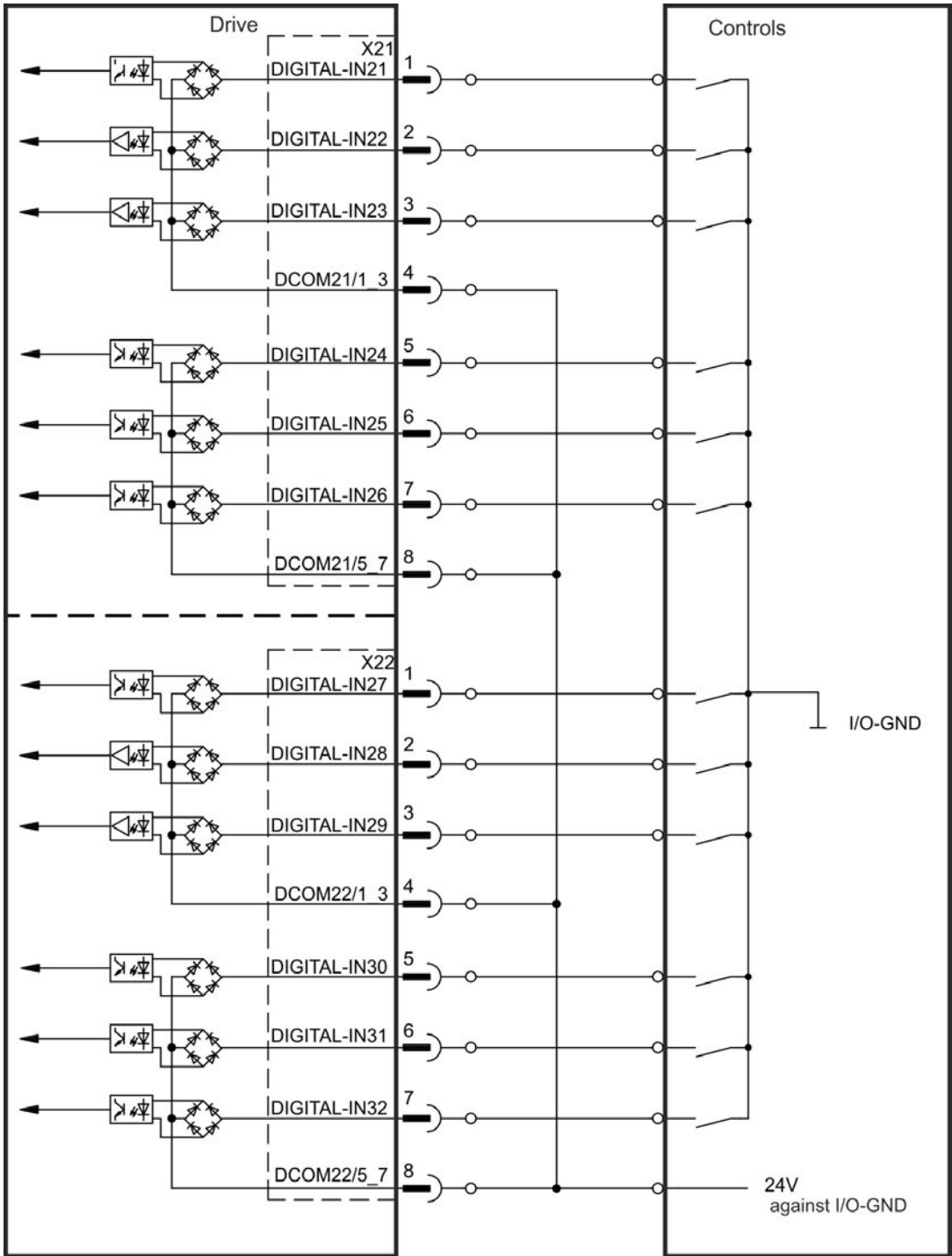

Digital Input Wiring Diagram (Sink type connection, example)

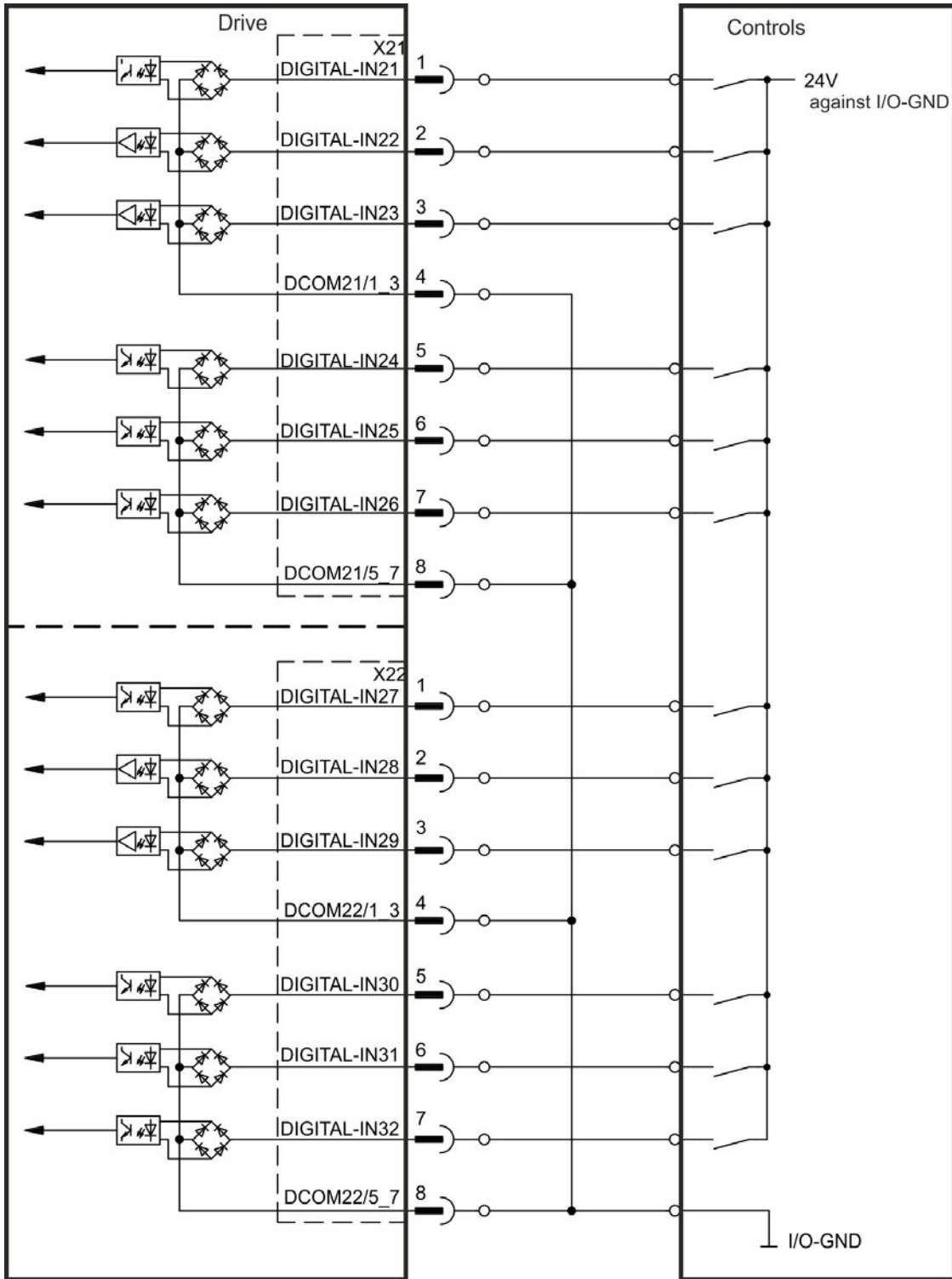

8.14.6 Digital Inputs (X35/X36) with AKD-M

In addition to the 8 digital inputs on X7 and X8 (→ # 144), the AKD PDMM provides 6 digital inputs on X35 and X36. These can be used to initiate pre-programmed functions that are stored in the drive. A list of these pre-programmed functions is included in the KAS IDE. If an input is programmed, it must be saved to the drive. By default, all inputs are not programmed (off). For more information refer to the setup software.

NOTE

Depending on the selected function the inputs are high or low active.

Technical characteristics

Choose the function you require in KAS IDE.

- Floating, reference common line is DCOM35 or DCOM36
- Sink or Source type sensors possible
- High: 3.5 to 30 V/2 to 15 mA , Low: -2 to +2 V/<15 mA
- Update rate: Software 250 μ s

The inputs can be used with switched +24 V (source type) or switched GND (sink type). See diagrams below for typical examples of digital input wiring.

Digital Input Wiring Diagram (Source type connection, example)

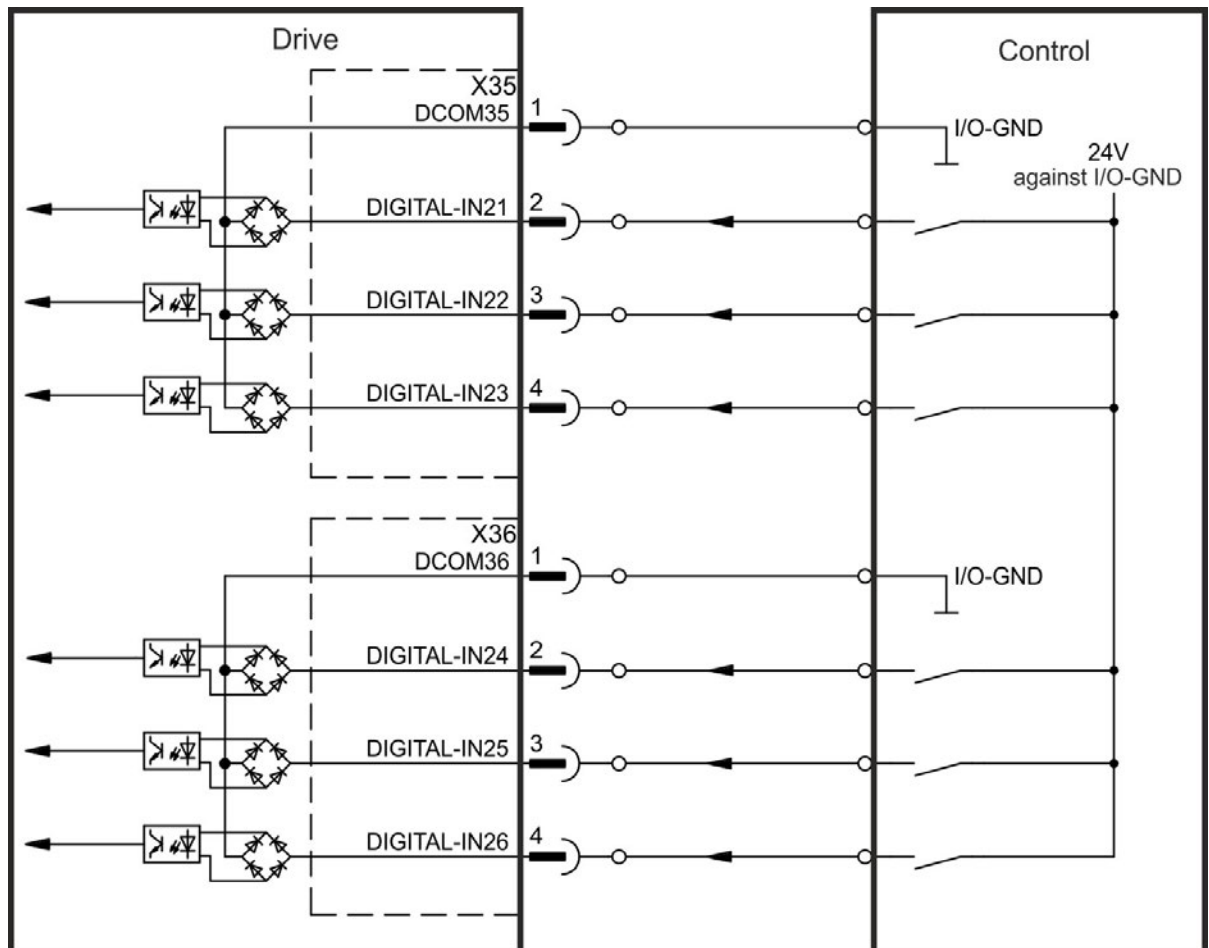

Digital Input Wiring Diagram (Sink type connection, example)

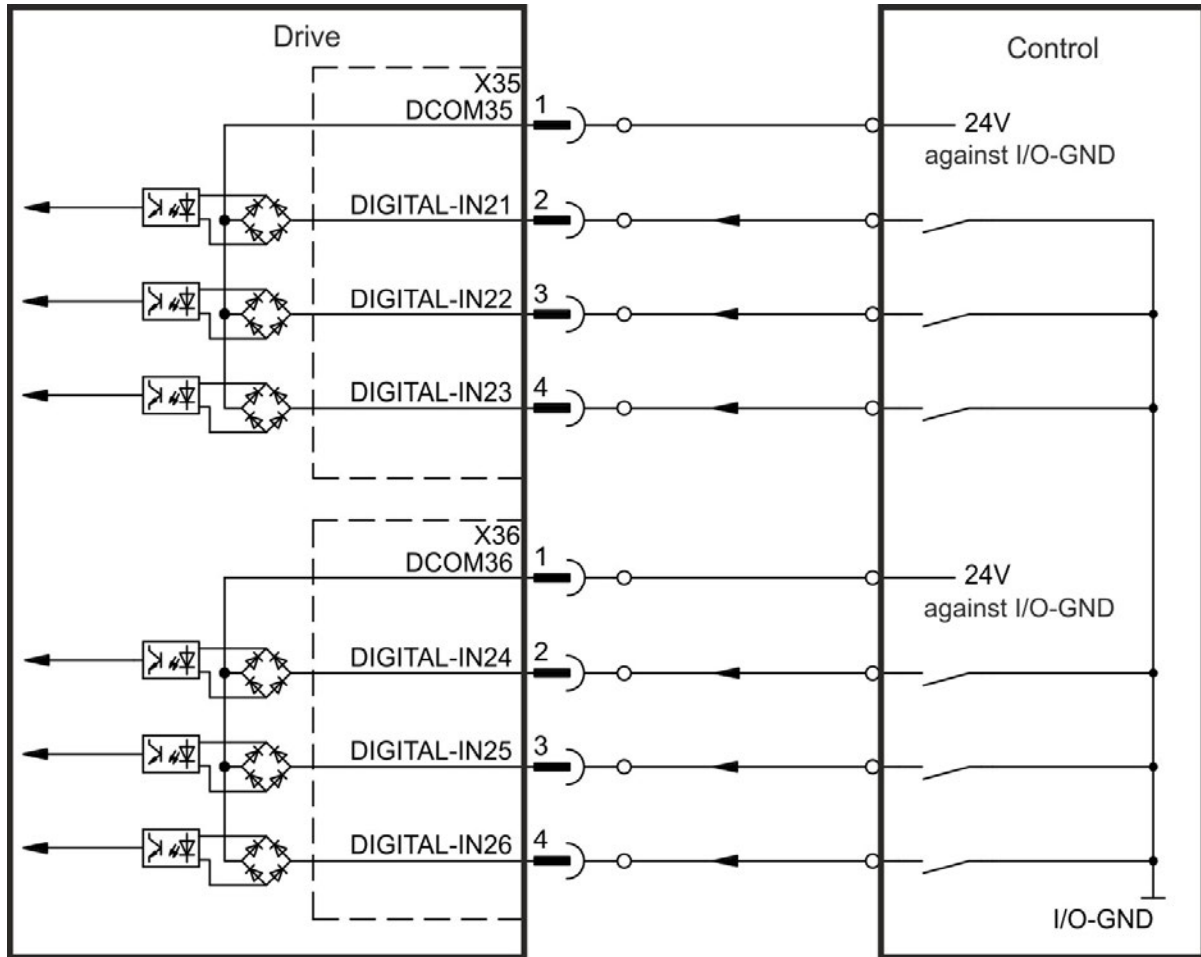

8.14.7 Digital Outputs (X7/X8)

8.14.7.1 Digital Outputs 1 and 2

The drive supplies 2 digital outputs (X7/5 to X7/8, (→ # 144). Choose the required function in the setup software. Messages from pre-programmed functions stored in the drive can be output here. A list of these pre-programmed functions can be found in the setup software. If an output is to be assigned to a pre-programmed function, then the parameter set must be saved in the drive.

Technical characteristics

- 24 V IO power supply at terminals X7/8 and X7/6, 20 VDC to 30 VDC
- All digital outputs are floating,
DIGITAL OUT 1/2: terminals X7/7-8 and X7/5-6), max. 100 mA
- Can be wired as active low or active high (see examples below)
- Update rate: 250 μ s

Wiring diagram

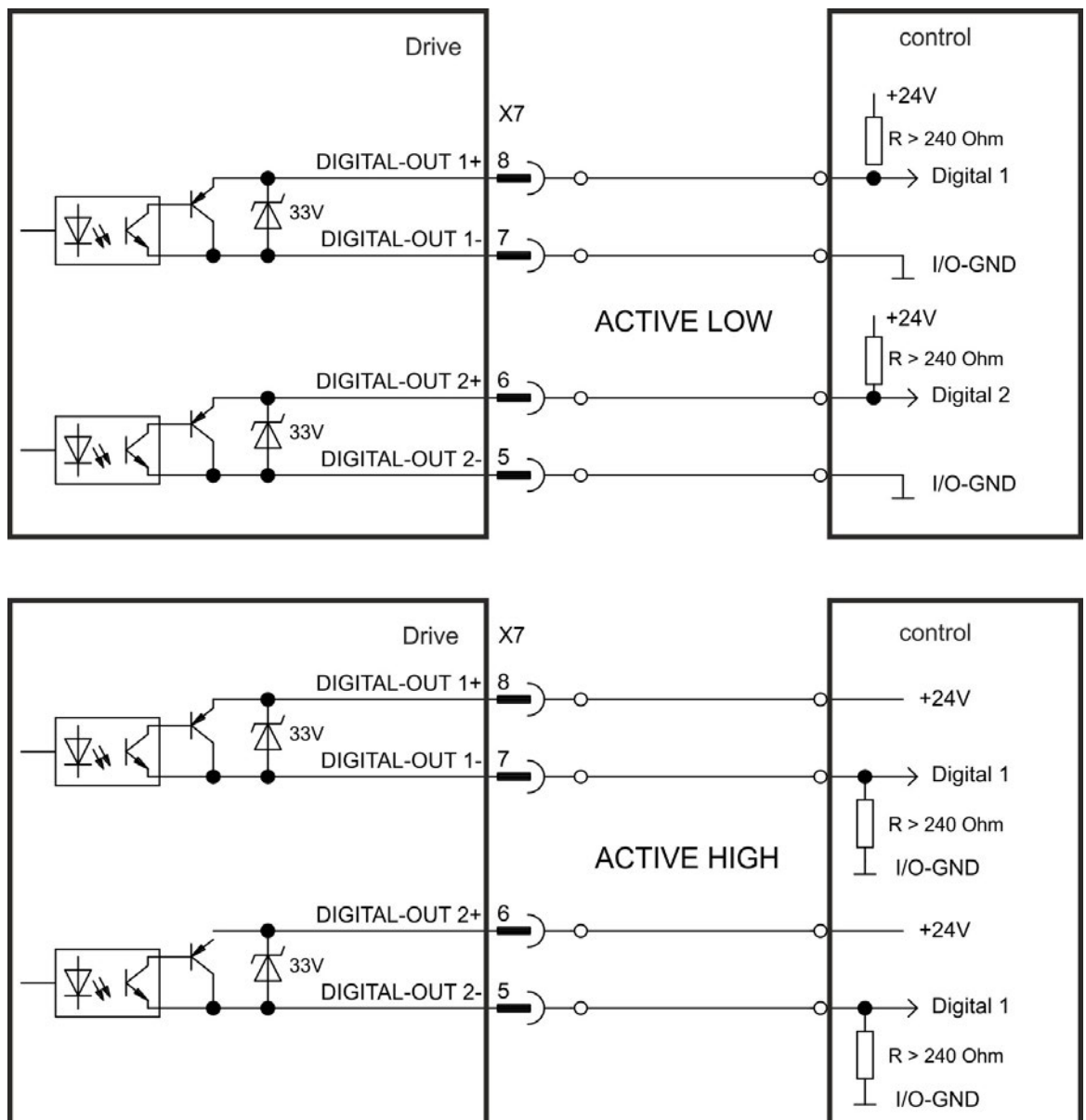

8.14.7.2 FAULT relay contacts

Operational readiness (terminals X8/1 and X8/2) is signaled by a floating relay contact.

The fault relay can be programmed to two modes of operation:

- Contact closed when there is no fault
- Contact closed when there is no fault and the drive is enabled.

The signal is not influenced by the enable signal, the I^2t -limit, or the regen threshold.

Technical characteristics

- FAULT: Relay output, max. 30 VDC or 42 VAC, 1 A
- Time to close: max. 10 ms
- Time to open: max. 10 ms

NOTE

All faults cause the FAULT contact to open and the output stage to be switched off (if the FAULT contact is open, the output stage is inhibited -> no power output). List of the fault messages: (→ # 199).

Wiring diagram

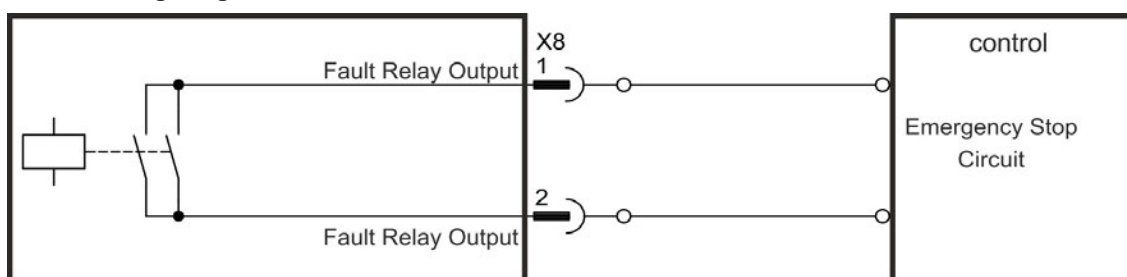

8.14.8 Digital Outputs with I/O option (X23/X24)

8.14.8.1 Digital Outputs 21 to 24, 26 to 29

The drive option "IC" provides 10 digital outputs (→ # 144). Choose the required function in the setup software. Messages from pre-programmed functions stored in the drive can be output here. A list of these pre-programmed functions can be found in the setup software. If an output is to be assigned to a pre-programmed function, then the parameter set must be saved in the drive.

Technical characteristics

- 24 V IO power supply, 20 VDC to 30 VDC, floating, max. 100 mA
- Can be wired as active low or active high (see examples below)
- Update rate: 250 μs

Wiring diagram

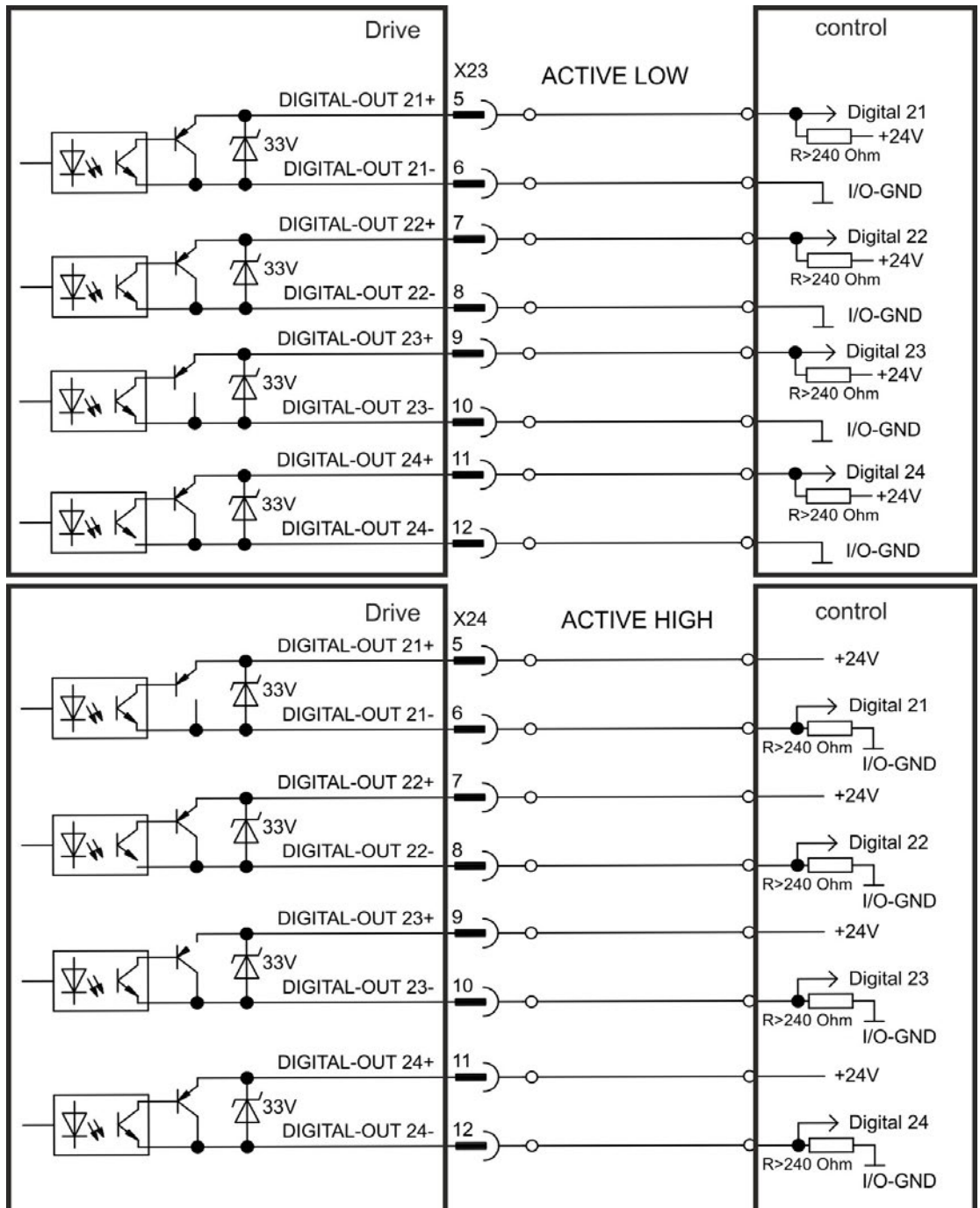

8.14.8.2 Digital Relay Outputs 25, 30

The drive option "IC" provides two digital outputs, which are signaled by floating relay contacts (→ # 144). Choose the required function in the setup software. Messages from pre-programmed functions stored in the drive can be output here. A list of these pre-programmed functions can be found in the setup software. If an output is to be assigned to a pre-programmed function, then the parameter set must be saved in the drive.

Technical characteristics

- Relay output, max. 30 VDC or 42 VAC, 1 A
- Time to close: max. 10 ms
- Time to open: max. 10 ms

Wiring diagram

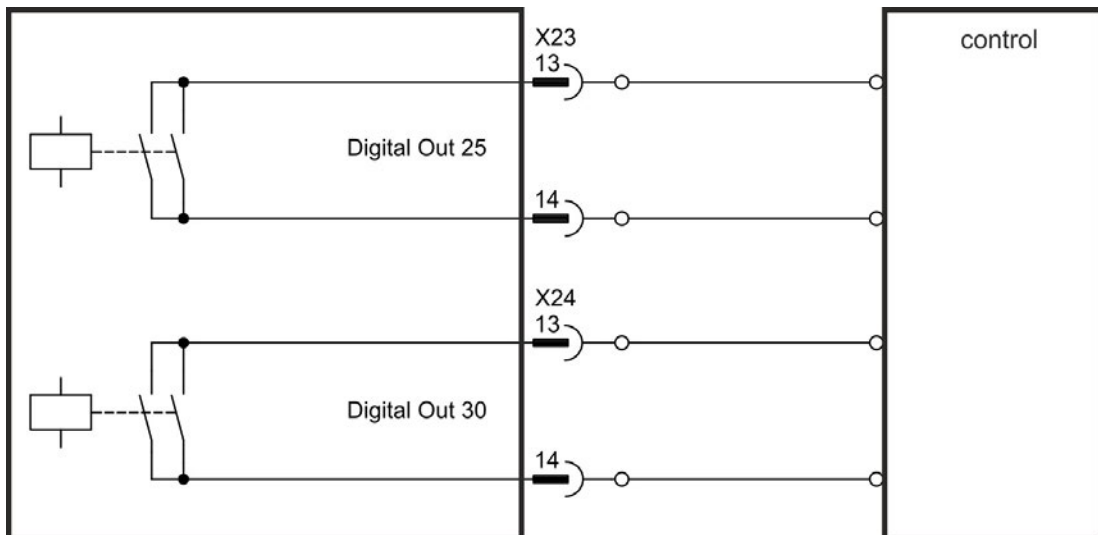

8.14.9 Digital Outputs (X35/X36) with AKD-M

8.14.9.1 Digital Outputs 21 and 22

In addition to the 2 digital outputs on X7 (→ # 144), the AKD PDMM provides 2 digital outputs on X35 and X36. Choose the required function in the setup software. Messages from pre-programmed functions stored in the drive can be output here. A list of these pre-programmed functions can be found in the setup software. If an output is to be assigned to a pre-programmed function, then the parameter set must be saved in the drive.

Technical characteristics

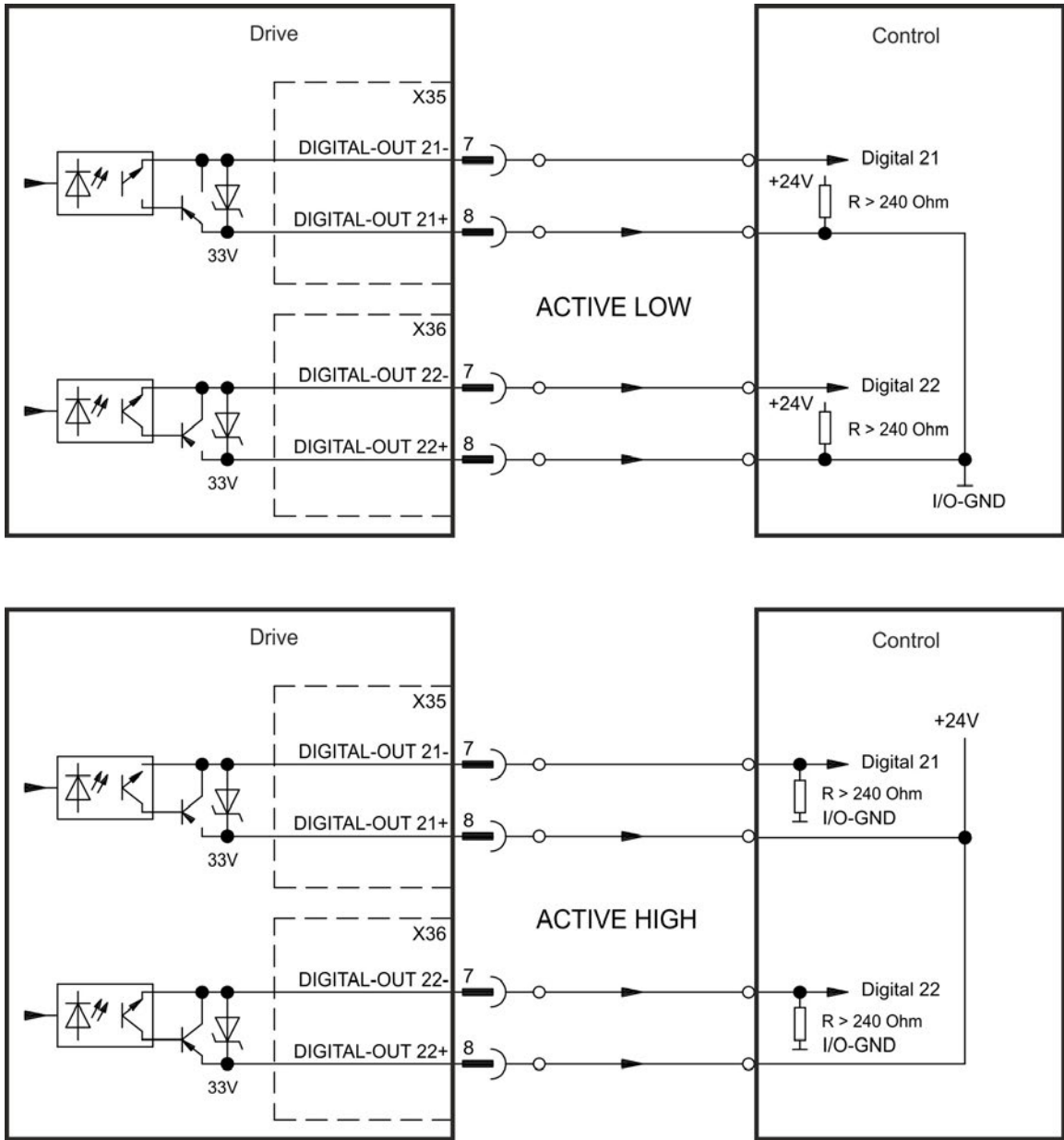

- 24 V IO power supply at terminals X35/8 and X36/8, 20 VDC to 30 VDC
- All digital outputs are floating, max. 100 mA
- Can be wired as active low or active high (see examples below)
- Update rate: 1 ms

Wiring diagram



8.15 LED display

The LED seven-segment display indicates the status of the drive after the 24 V supply is switched on. If the service connection to the PC or to the PAC doesn't work, then the LED display is the only way to get information.

AKD two digits	AKD-M two + one digits
 <p>The image shows a Kollmorgen AKD LED display with two digits highlighted by a red circle. The display shows '88'.</p>	 <p>The image shows a Kollmorgen AKD-M LED display with two digits and one digit highlighted by red circles. The two digits show '88' and the one digit shows '8'.</p>
<p>AKD fault codes or warning codes are displayed constantly if present. Fault messages are coded with "F" or "E", warnings are coded with "n". The IP address can be flashed across the LED display if the B1 button is pressed.</p>	<p>The two digits LED display indicates the AKD messages. Fault messages are coded with "F", warnings are coded with "n".</p> <p>The one digit LED indicates the PDMM messages of the AKD PDMM. Error messages are coded with "E", warnings (alarms) are coded with "A". Status of application programs are indicated as well. With pushbuttons B2 and B3 a menu with several functions can be started (→ # 165).</p>

See WorkBench Onlinehelp for details.

Display Codes (overview)	Status
o0, o1, o2 ...	Normal operation, operation mode 0 or 1 or 2 ..., no faults
Fx	Fault (see (→ # 199)
nx	Warning (see (→ # 199)
IPx	Displaying drive IP address
--	Powered on and FPGA loading. If continuous then operational and resident FPGA images are corrupt.
[.]	Drive enabled
[.] (flashing)	Drive in an internal dynamic brake mode (DRV.ACTIVE = 3).
dx	Firmware download

8.16 Rotary Switches (S1, S2, RS1)

Rotary switches can be used to select IP address or predefined functions for executing.

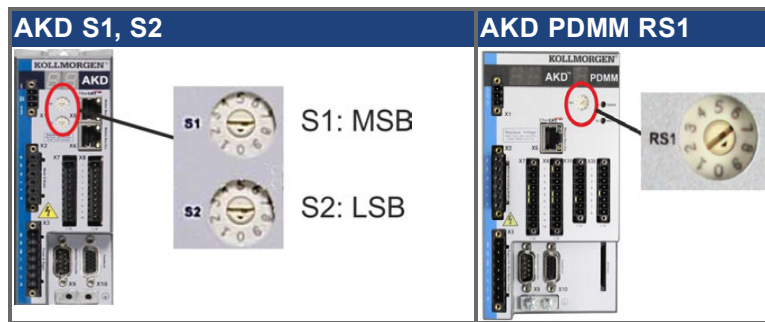

8.16.1 Rotary switches S1 and S2 with AKD-B, -P, -T

S1	S2	Function	Set while	Remarks
0	0	DHCP IP	24 V is OFF	The drive acquires its IP address from an external DHCP server, details see (→ # 169).
x	y	Static IP	24 V is OFF	The IP address is 192.168.0.nn, valid values are 01 to 99, details see (→ # 169).
AKD-x****-CC only				
8	9	DRV.TYPE toggle	24 V is ON and drive is disabled	Press B1 for 3s to switch over from CAN to EtherCAT fieldbus or vice versa (→ # 173) and (→ # 178). Switch 24V off and on again.
AKD with I/O option card only				
1	0	Load data	24 V is ON and AKD is disabled	Press B1 for 5s for loading data from the SD card to the drive, details see (→ # 166).
1	1	Save data	24 V is ON and AKD is disabled	Press B1 for 5s for save data from the drive to the SD card, details see (→ # 166).
AKD-T only				
1	2	Stop program	24 V is ON	Press B1 for 5s for stopping the BASIC program
1	3	Restart program	24 V is ON	Press B1 for 5s for restarting the BASIC program

8.16.2 Rotary switch RS1 with AKD-M

RS1	Function	Set while	Remarks
0	DHCP IP	24 V is OFF	The drive will acquire its IP address from an external DHCP server (→ # 171).
1	Static IP	24 V is OFF	The IP address is software configurable from a web-browser (→ # 171).
2 to 9	Static IP	24 V is OFF	The IP address is 192.168.0.10n, valid values are 2 to 9 (→ # 171).

8.17 Pushbuttons (B1, B2, B3)

The pushbuttons can be used to start predefined functions.

8.17.1 Pushbutton B1 with AKD-B, -P, -T

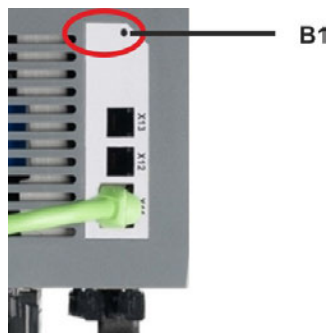

Function	Pushbutton	Remarks
Display IP address	B1	Press short to display the IP address in the two digit display
Switches Drive Type of AKD-x***CC model	B1	Set rotary switches S1 to 8 and S2 to 9. Press B1 for 3 sec to switch over from CAN to EtherCAT or reverse.
Load data from SD card	B1	Drives with I/O option card only. Set rotary switches S1 to 1 and S2 to 0. Press B1 for 5s for loading data from the SD card to the drive.
Save data to SD card	B1	Drives with I/O option card only. Set rotary switches S1 to 1 and S2 to 1. Press B1 for 5s for save data from the drive to the SD card.

8.17.2 Pushbuttons B1, B2, B3 with AKD-M

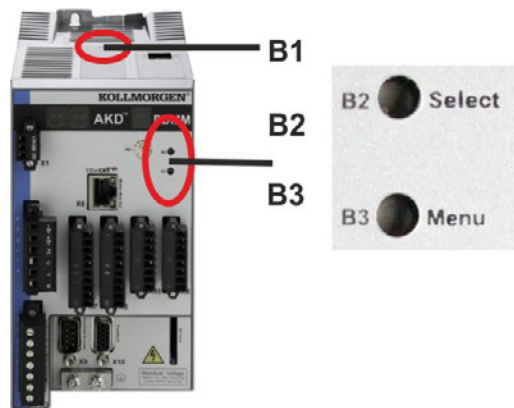

Function	Pushbutton	Remarks
-	B1	Unused
Boot-time functions (press and hold button during power-on boot sequence)		
Recovery Mode	B2	Press and hold to boot into recovery mode.
Menu	B3	Press and hold to block the application auto-start and to start cycling through the menu items.
Operational functions (press button during normal operation mode)		
Menu	B3	Press to cycle through the menu items. The menu items will be displayed on the 7-segment LED repeatedly for 10 s and can be selected by pressing B2.
Select Menu Item	B2	Press while the required menu item is displayed to perform action. Application is running , available menu items: <ul style="list-style-type: none"> • 'IP' address • 'stop' application (confirm) No application is running , available menu items: <ul style="list-style-type: none"> • 'IP' address • 'start' application (confirm) • 'reset' to defaults (confirm) • 'backup' to SD card (confirm) (→ # 167) • 'restore' from SD card (confirm) (→ # 167)
Confirm	B2	If the selected menu item selection requires a confirmation, "y" is displayed for 10 s - press B2 to confirm.

8.18 SD Card Slot

8.18.1 SD Card Slot with I/O option card

Drives with I/O option card offer a SD card slot to activate file transfers from/to the AKD and SD Memory Card. These features can be started from the WorkBench software or with push-button B1 (top of the drive) combined with rotary switch setting 10 or 11. Detailed description can be found in the WorkBench Onlinehelp.

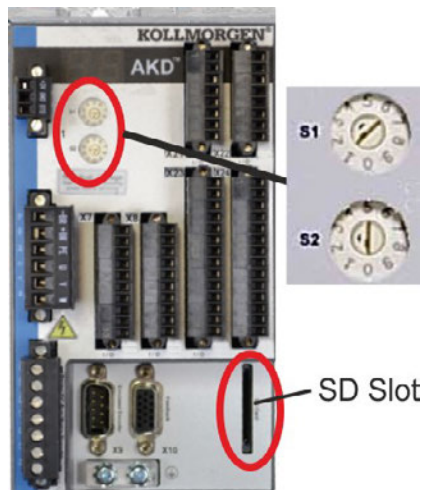

NOTE

The save/load operations (AKD to SD or SD to AKD) are only possible while no program is running and the drive is disabled.

BASIC programs and non volatile parameters can be saved/loaded.

If a fault occurs during save/load operations, the fault number is displayed in the display with E followed by four digits. Error codes (→ # 199) .

Supported SD card types

SD cards are preformatted by the manufacturer. The following table outlines the SD card types and AKD support.

SD Type	File System	Capacity	Supported
SD (SDSC)	FAT16	1MB to 2GB	YES
SDHC	FAT32	4GB to 32GB	YES
SDXC	exFAT (Microsoft)	>32GB to 2TB	NO

Features

If an SD card is plugged into the SD slot and the drive is disabled and no programm is running, set rotary switches as described below and press B1 for 5s to start the set function:

Function	S1	S2	Remarks
Save data to SD card	1	1	Press B1 for 5s for save data from the drive to the SD card.
Load data from SD card	1	0	Press B1 for 5s for loading data from the SD card to the drive.

8.18.2 SD Card Slot with AKD-M

AKD PDMM offers a SD card slot and pushbuttons B2 and B3 to activate file transfers from/to the AKD PDMM and SD Memory Card. These features can be started from the KAS IDE software as well. Detailed description can be found in the KAS IDE Online Help.

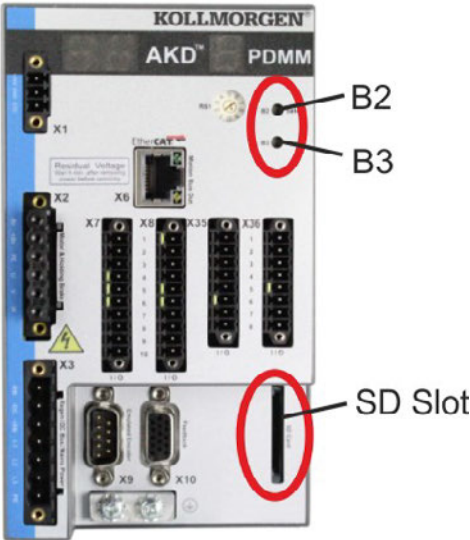

The backup/restore operations (AKD PDMM to SD or SD to AKD PDMM) will not be possible if an application is running.

NOTE

Stop the application from the web-browser or use the B2/B3 “stop” action before initiating any SD card functionality.

If a fault occurs during save/load operations, the fault number is displayed in the one digit display with E followed by two digits. Error codes (→ # 205) .

Supported SD card types

SD cards are preformatted by the manufacturer. The following table outlines the SD card types and AKD PDMM support.

SD Type	File System	Capacity	Supported
SD (SDSC)	FAT16	1MB to 2GB	YES
SDHC	FAT32	4GB to 32GB	YES
SDXC	exFAT (Microsoft)	>32GB to 2TB	NO

Features

If an SD card is plugged into the SD slot and no application programm is running, the push-button menu (started with B3, (→ # 164) shows the possible data transfer functions:

- 'backup' to copy firmware, configurations, user application, and user data files from the AKD PDMM to SD card.
- 'restore' to load firmware, configuration, user application, and user data files from SD card to AKD PDMM.

8.19 Service Interface (X11, X32)

Operating, position control, and motion-block parameters can be set up by using the setup software on an ordinary commercial PC (→ # 184).

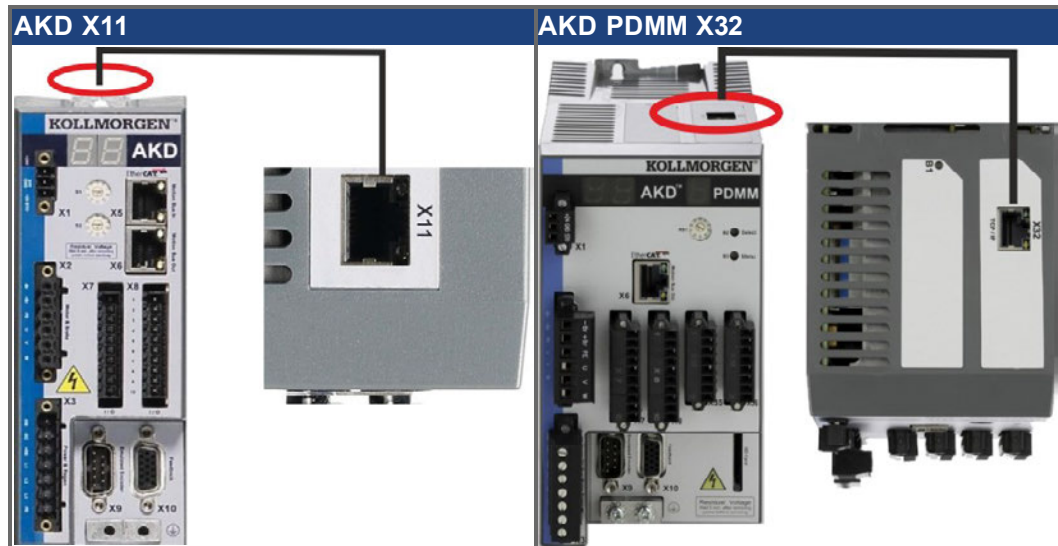

Connect the service interface (X11 or X32) of the drive to an Ethernet interface on the PC directly or via a network hub/switch, **while the supply to the equipment is switched off.** Use standard Cat. 5 Ethernet cables for connection (in some cases crossover cables will also work).

Confirm that the link LED on the AKD (the green LED on the RJ45 connector) and on your PC (or network Hub/Switch) are both illuminated. If both lights are illuminated, then you have a good electrical connection.

8.19.1 Pinout X11, X32

Pin	Signal	Pin	Signal
1	Transmit +	5	n.c.
2	Transmit -	6	Receive-
3	Receive+	7	n.c.
4	n.c.	8	n.c.

8.19.2 Service Bus Protocols X11, X32

Protocol	Type	Connector
Modbus TCP	Service Bus	X11, X32
Ethernet TCP/IP	Service Bus	X11, X32

8.19.3 Possible Network Configurations

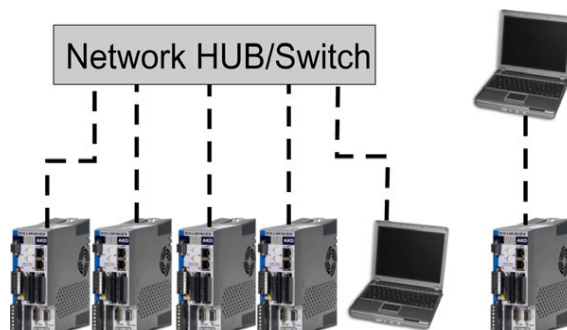

8.19.4 Setting the IP Address AKD-B, AKD-P, AKD-T

The IP address can be flashed across the LED display if the B1 button is pressed.



You can use the rotary switches to set the IP address of the AKD. For CANopen and some other fieldbuses, the rotary switches also set the node address of the drive for that specific network.

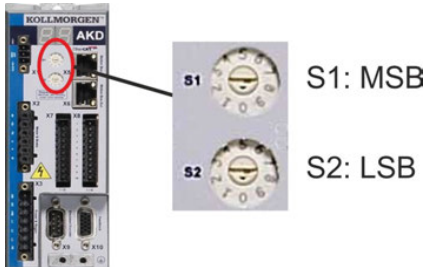

Rotary Switch Setting	Drive IP Address
00	DHCP/AutoIP address. The IP address of the drive is obtained from the DHCP server on your network. If no DHCP server is found the IP addresses is an AutoIP address (it is internally generated following the AutoIP protocol and will be of the form 169.254.xx.xx).
01 to 99	Static IP Address. The IP address is 192.168.0.nn, where nn is the number from the rotary switch. This setting generates addresses in a range from 192.168.0.1to 192.168.0.99. Example:if S1 is set to 2 and S2 is set to 5 – the IP address is 192.168.0.25

NOTE

The PC subnet mask must be set to 255.255.255.0 or 255.255.255.128
When connecting the AKD directly to a PC, use static IP addressing (not 00).

Static IP addressing

When connecting the drive directly to a PC, static IP addressing must be used. Set rotary switches S1 and S2 to a number different from 00 (see table above).

Dynamic IP addressing (DHCP and Auto-IP)

With S1 and S2 both set to 0, the drive is in DHCP mode. The drive will acquire its IP address from an external DHCP server if present in the network. If a DHCP server is not present, the drive will assume an Automatic Private IP Address of the form 169.254.x.x.
If your PC is directly connected to the drive, and set to obtain an IP address automatically in the TCP/IP settings, a connection will be established with both devices using compatible automatically generated addresses. It can take up to 60 seconds for a PC to configure an Automatic Private IP Address (169.254.x.x).

Changing the IP address

If the switches are altered while 24 V Logic power is supplied to the drive, you must switch off and then switch on again the 24 V supply voltage. This action will reset the address.

IP address mode

By default, the drive utilizes the method described above to acquire its IP address. A method of setting the IP address independent of the Rotary switches is available. More information is available in the *WorkBench Online Help* or in the Settings Screen-> Fieldbus-> TCP/IP screen in WorkBench.

Recovering Communications with a Drive on an Un-Reachable IP Address

If IP.MODE has been set to 1 (using software defined static IP), the drive will boot up on an IP Address that may be unreachable with the host computer's settings.

If the IP address prevents communication, the IP settings can be reset to default by the following procedure:

- Set both rotary switches to 0
- Hold down button B1 (top-side of drive) for 5 seconds.

The display will flash 0.0.0.0 and then attempt to discover an address by DHCP.

Without removing logic power from the drive, use WorkBench to connect to the drive, reconfigure the IP address settings as desired, and store the values to non-volatile memory.

8.19.5 Setting the IP Address AKD-M

You can use the rotary switch RS1 to set the IP address of the AKD PDMM. The configured IP address (depending on the current rotary switch RS1 position) will be displayed on the 7 segment at Ethernet cable connection time and at power-on, if an Ethernet cable is connected.. If no Ethernet cable is connected, no IP address will be indicated in the display.

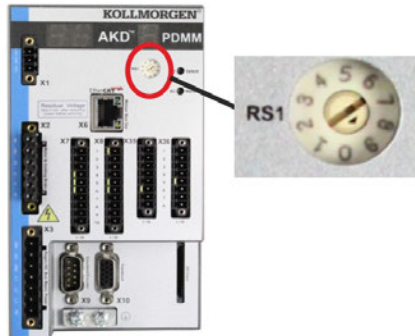

Rotary Switch Setting	Drive IP Address
0	DHCP/AutoIP address. The IP address of the drive is obtained from the DHCP server on your network. If no DHCP server is found the IP addresses is an AutoIP address (it is internally generated following the AutoIP protocol and will be of the form 169.254.xx.xx).
1	Static IP Address. The IP address is software configurable from a web-browser. The default IP address at switch position 1 is 192.168.1.101. To configure the IP address, open a web browser and type the IP address in the URL box. The AKD PDMM web page will appear. Navigate to the Settings tab and then the Network tab to configure the static IP address for the AKD PDMM.
2 to 9	Static IP Address. The IP address is 192.168.0.10n, where n is the number from the rotary switch. This setting generates addresses in a range from 192.168.0.102 to 192.168.0.109. Example:if RS1 is set to 5 – the IP address is 192.168.0.105

NOTE

The PC subnet mask must be set to 255.255.255.0 or 255.255.255.128

Static IP addressing

When connecting the drive directly to a PC, static IP addressing must be used. Set rotary switch RS1 to a number from 2 to 9 (see table above)

Dynamic IP addressing (DHCP and Auto-IP)

With RS1 set to 0, the drive is in DHCP mode. The drive will acquire its IP address from an external DHCP server if present in the network. If a DHCP server is not present, the drive will assume an Automatic Private IP Address of the form 169.254.x.x.

If your PC or PAC is directly connected to the drive, and set to obtain an IP address automatically in the TCP/IP settings, a connection will be established with both devices using compatible automatic generated addresses. It can take up to 60 seconds for a PC to configure an Automatic Private IP Address (169.254.x.x).

Changing the IP address

If the switch is altered while 24 V Logic power is supplied to the drive, you must switch off and then switch on again the 24 V supply voltage. This action will reset the address.

8.19.6 Modbus TCP

The drive can be connected to Modbus HMI via RJ-45 connector X11 (AKD) or X32 (AKD PDMM, for Kollmorgen touchpanels only). The protocol allows reading and writing of drive parameters.

The communication status is indicated by the built-in LEDs.

Connector	LED#	Name	Function
X11, X32	LED1	IN port Link	ON = active, OFF= not active
	LED2	RUN	ON = running, OFF = not running

Connect the service interface (X11, X32) of the drive to an Ethernet interface on the Modbus HMI directly or via a network switch, **while the supply to the equipment is switched off**. Use standard Cat. 5 Ethernet cables for connection.

The following are required to connect an HMI to the drive:

- The HMI must support Modbus TCP.
- It must have Ethernet hardware and a driver for Modbus TCP, though the driver does not have to be made specifically for the AKD family.

The Kollmorgen AKI HMI's are compatible with a "Kollmorgen Modbus Master" driver.

The subnet mask of the AKD is 255.255.255.0. The first three octets of the drive's IP address must be the same as the first three octets of the HMI's IP address. The last octet must be different.

Confirm that the link LED on the AKD (the green LED on the RJ45 connector) and on your Master or Switch are both illuminated. If both lights are illuminated, then you have a good electrical connection.

Modbus TCP and WorkBench/KAS IDE can operate simultaneously if a switch is used.

8.20 CAN-Bus Interface (X12/X13)

Two 6-pin RJ-25 connectors X12/X13 are used for CAN-Bus connection.



Conn.	Pin	Signal	Conn.	Pin	Signal
X12	1	Internal Termination Resistor	X13	1	Internal Termination Resistor
X12	2	CAN Shield	X13	2	CAN Shield
X12	3	CANH in	X13	3	CANH out
X12	4	CANL in	X13	4	CANL out
X12	5	GND	X13	5	GND
X12	6	Internal Termination Resistor	X13	6	Internal Termination Resistor

8.20.1 CAN-Bus activation with AKD-CC models

AKD-CC drive models are Drives, which support EtherCAT and CAN fieldbus types within one common software. These CC drive models allow selecting a fieldbus support by setting the DRV.TYPE parameter to a certain value. CC drive models are delivered with EtherCAT set active.

To activate CANopen, the DRV.TYPE parameter must be changed

1. by software: connect the PC to the AKD and change the parameter DRV.TYPE in the WorkBench terminal screen (see DRV.TYPE parameter documentation) or
2. by hardware: with the rotary switches S1 & S2 at the front and the button B1 on the top side of the Drive.

The following steps are needed for changing the fieldbus type from EtherCAT to CAN with the rotary switches.

1. Set the rotary switches on the front side of the AKD to the value of 89.

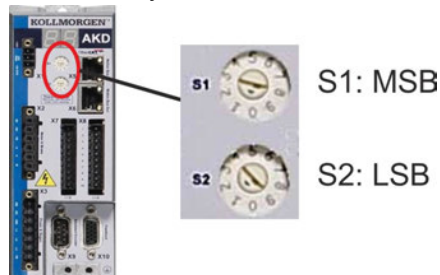

Set S1 to 8 and S2 to 9

2. Press the button B1 for about 3 seconds (starts DRV.NVSAVE).
Press B1 for 3 seconds.



The seven segment display shows **Cn** during the process of changing DRV.TYPE to CAN.

Do not switch off the 24[V] power supply while the seven segment shows Cn!

3. Wait until the seven segment display goes back to the original state, no the drive is prepared for CAN.
4. Power cycle the drive by switching the 24 V power supply **off** and then **on** again.

NOTE

The seven segment display shows Er (Error) in case that the DRV.TYPE instruction failed. In this case please power cycle the drive and contact the Kollmorgen customer support for further help.

8.20.2 Baud rate for CAN-Bus

The user can decide to use a fixed baud rate or an auto baud detection algorithm for the start-up behavior of the drive. The transmission rate can be set via the parameter **FBUS.PARAM01**. The parameter FBUS.PARAM01 can either be set via WorkBench or via a special mechanism with the rotary switches in the AKD front.

Baud rate [kBit/s]	FBUS.PARAM01	Upper rotary switch S1	Lower rotary switch S2
auto detect	0	9	0
125	125	9	1
250	250	9	2
500	500	9	3
1000	1000	9	4

In case of a fix baud rate, the drive sends the boot up message with the baud rate saved in the drive's non volatile memory after a power cycle. In case of auto baud detection, the drive listens for a valid CAN frame on the bus. When a valid frame is received, the drive sends the boot up message with the measured bit time. The baud rate can either be stored afterwards to non volatile memory via object 1010 sub 1, or the auto baud mechanism is used always.

NOTE

For reliable auto baud detection, it is recommended to use suitable cabling of the CAN-Bus (two terminators, GND connection etc.). The drive needs to be disabled, if auto baud is in use.

For setting the baud rate with rotary switches, follow the procedure below:

1. Disable the drive.
2. Set the rotary switches to either 90 to 94 (see above table).

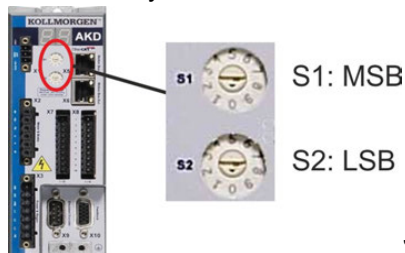

Set S1 to 9 and S2 to either 0 or 4

3. Push the button B1 on the AKD for at least 3 seconds until the rotary switch setting is displayed on the AKD-display.



4. When the display blinks with the set rotary switch setting stop pushing B1 and wait until the blinking stops. During that time the parameter FBUS.PARAM01 is set to the new value and all parameters are stored to the non volatile memory. The new setting will be taken with the next power-up of the drive.

If an error occurred, the following error messages will flash 5 times:

- E1 - Drive is enabled
- E2 - Non-volatile storage of the new setting failed
- E3 - Invalid rotary switch selection

8.20.3 Node Address for CAN-Bus

NOTE

After changing the node address, you must turn off the 24 V auxiliary supply for the drive and then turn it on again.

During setup, use the rotary switches on the AKD front panel to preset the station address for communication.

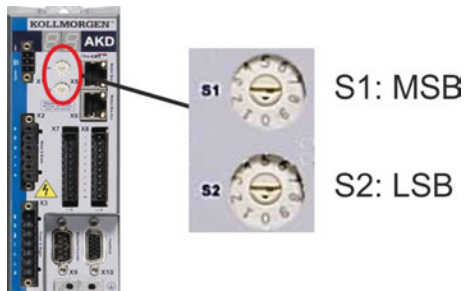

The rotary switches on the front of the AKD (S1&S2) correspond to the CAN node address. The S1&S2 switches also correspond to the IP address setting of the drive. Both CAN and IP network address schemes have to be configured to account for this dependence if both TCP/IP and CAN networks are running at the same time in an application. Example:

S1 (MSB)	S2 (LSB)	CAN address	IP address
4	5	45	192.168.0.45

The IP address setting can be decoupled from the rotary switches using WorkBench (Settings -> Fieldbus-> TCP/IP).

8.20.4 CAN-Bus Termination

The last bus device on both ends of the CAN-Bus system must have termination resistors. The AKD has built-in 132 ohms resistors that can be activated by connecting pins 1 and 6. An optional termination plug is available for AKD (*P-AKD-CAN-TERM*). The optional termination plug is an RJ-12 connector with an enclosed wire jumper between pins 1&6. The termination plug should be inserted into the X13 connector of the last drive in the CAN network.

NOTE

Remove the termination connector if the AKD is not the last CAN-Bus device and use X13 for connecting the next CAN node.

8.20.5 CAN-Bus Cable

To meet ISO 11898, a bus cable with a characteristic impedance of 120 ohms should be used. The maximum usable cable length for reliable communication decreases with increasing transmission speed. As a guide, you can use the following values which Kollmorgen has measured; however, these values are not assured limits:

- Characteristic impedance: 100–120 ohms
- Cable capacitance max.: 60 nF/km
- Lead loop resistance: 159.8 ohms/km

Transmission Rate (kBaud)	1,000	500	250
Maximum Cable Length (m)	10	70	115

Lower cable capacitance (max. 30 nF/km) and lower lead resistance (loop resistance, 115 ohms/1000m) make it possible to achieve greater distances. The characteristic impedance 150 ± 5 ohms requires terminating resistor 150 ± 5 ohms.

8.20.6 CAN-Bus Wiring

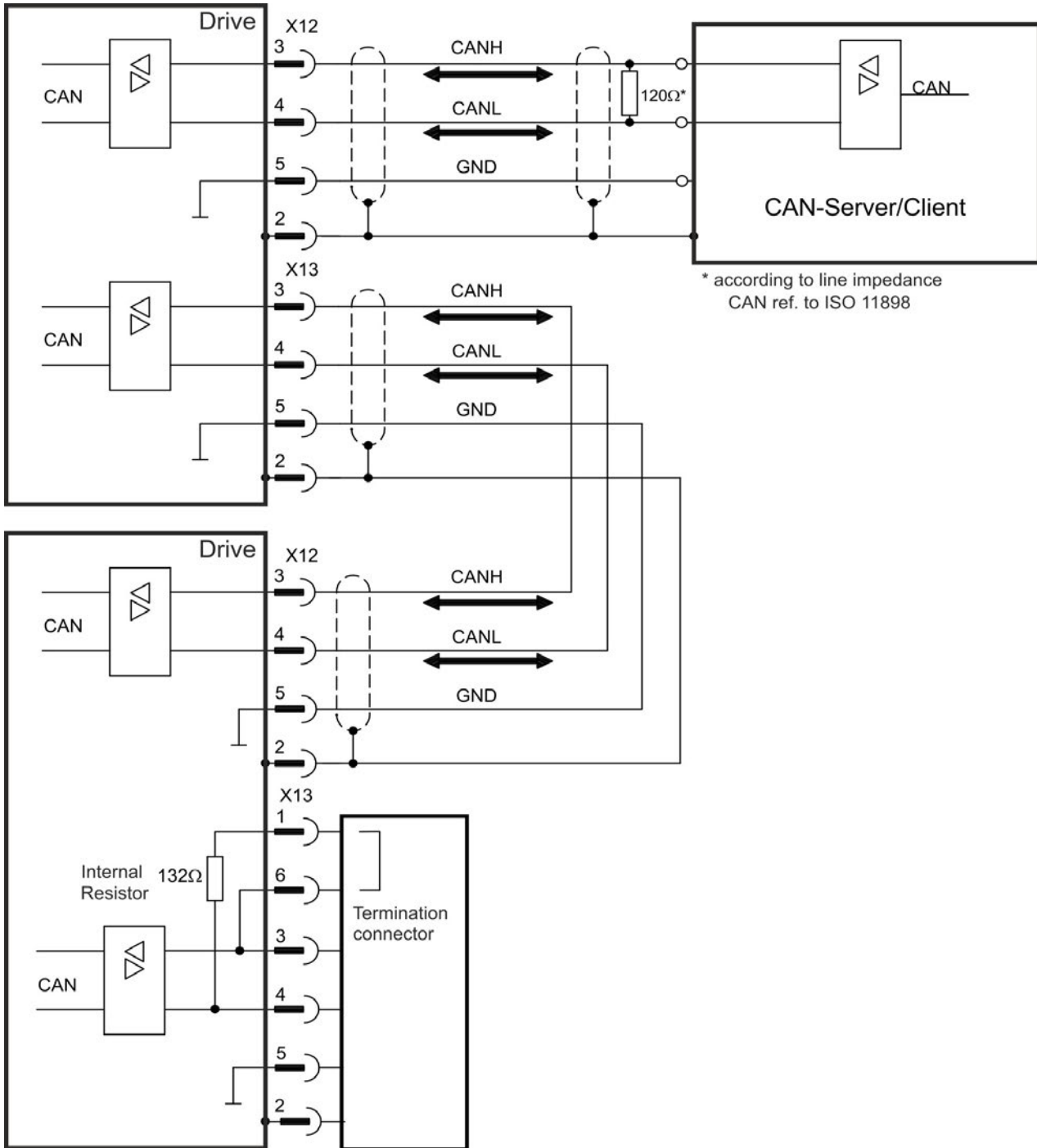

8.21 Motion Bus Interface (X5/X6/X11)

The motion bus interface has RJ-45 connectors and can be used for communicating with various fieldbus devices depending on the used drive version.

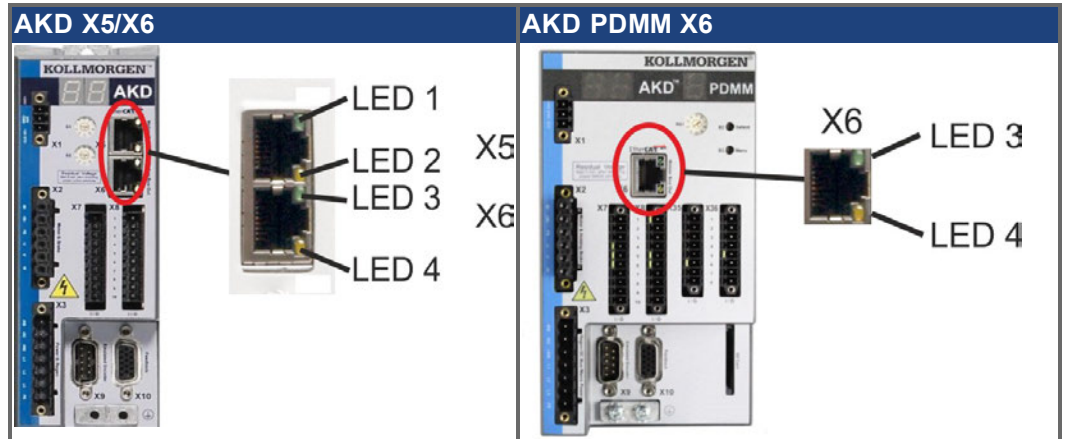

NOTICE

Do not connect the Ethernet line for the PC or PAC with the set up software to the motion bus interface X5/X6. The set up Ethernet cable must be connected to X11 or X32.

8.21.1 Pinout X5, X6, X11

Pin	Signal X5	Signal X6	Signal X11
1	Transmit +	Receive+	Transmit +
2	Transmit -	Receive-	Transmit -
3	Receive+	Transmit +	Receive+
4, 5	n.c.	n.c.	n.c.
6	Receive-	Transmit -	Receive-
7, 8	n.c.	n.c.	n.c.

8.21.2 Bus Protocols X5, X6, X11

Protocol	Type	Connectivity Option	Connector
EtherCAT	Motion bus	EC or CC	X5, X6
SynqNet	Motion bus	SQ	X5, X6
sercos® III	Motion bus	S3	X5, X6
PROFINET RT	Motion bus	PN	X11
Ethernet/IP	Motion bus	EI	X11

8.21.3 EtherCAT

AKD drives (connection variants EC and CC) can be connected as slaves to the EtherCAT network (CoE) via RJ-45 connectors X5 (in port) and X6 (out port). The communication status is indicated by the built-in connector LEDs.

AKD PDMM drives (AKD-M) acts as an EtherCAT (CoE) master and therefore provides the X6 connector (out) for a string topology with 250 ms cycle time and maximum 8 slaves.

Drive variant	Connector	LED#	Name	LED function ON	LED function OFF
AKD	X5	LED1	Link In	active	not active
		LED2	Run	running	not running
AKD and AKD PDMM	X6	LED3	Link Out	active	not active
		LED4	-	-	-

8.21.3.1 EtherCAT activation with AKD-CC models

AKD-CC drive models are Drives, which support EtherCAT and CAN fieldbus types within one common software. CC drive models are delivered with EtherCAT set active. If you must change a drive from CANopen to EtherCAT, the DRV.TYPE parameter must be changed

1. by software: connect the PC to the AKD and change the parameter DRV.TYPE in the WorkBench terminal screen (see DRV.TYPE parameter documentation) or
2. by hardware: with the rotary switches S1 & S2 at the front and the button B1 on the top side of the Drive.

The following steps are needed for changing the fieldbus type from CAN to EtherCAT with the rotary switches.

1. Set the rotary switches on the front side of the AKD to the value of 89.

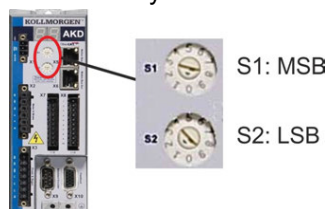

2. Press the button B1 for about 3 seconds (starts DRV.NVSAVE).
Press B1 for 3 seconds.



The display shows **En** during the process of changing DRV.TYPE to EtherCAT.
Do not switch off the 24[V] power supply while the seven segment shows En!

3. Wait until the display returns to the original state.
4. Power cycle the drive by switching the 24 V power supply **off** and then **on** again.

NOTE

The seven segment display shows Er (Error) in case that the DRV.TYPE instruction failed. In this case please power cycle the drive and contact the Kollmorgen customer support for further help.

8.21.4 SynqNet

You can connect to the SynqNet Network via RJ-45 connectors X5 (in port) and X6 (out port). The communication status is indicated by the built-in LEDs.

Connector	LED#	Name	Function
X5	LED1	LINK_IN	ON = receive valid (IN port) OFF = not valid, power off, or reset.
	LED2	CYCLIC	ON = network cyclic BLINK = network not cyclic OFF = power off, or reset
X6	LED3	LINK_OUT	ON = receive valid (OUT port) OFF = not valid, power off, or reset
	LED4	REPEATER	ON = repeater on, network cyclic BLINK = repeater on, network not cyclic OFF = repeater off, power off, or reset

8.21.5 PROFINET

AKD with connectivity option **PN** can be connected to a PROFINET network via RJ-45 connector X11. PROFINET RT protocol is used. The communication status is indicated by the built-in LEDs.

Connector	LED#	Name	Function
X11	LED1	IN port Link	ON = active, OFF = not active
	LED2	RUN	ON = running, OFF = not running

Connect the service interface (X11) of the drive to an Ethernet interface on the PROFINET Master directly or via a network switch, **while the supply to the equipment is switched off**. Use standard Cat. 5 Ethernet cables for connection.

Confirm that the link LED on the AKD (the green LED on the RJ45 connector) and on your Master or Switch are both illuminated. If both lights are illuminated, then you have a good electrical connection.

The subnet mask of the AKD is 255.255.255.0. The first three octets of the drive's IP address must be the same as the first three octets of the HMI's IP address. The last octet must be different.

PROFINET RT and WorkBench can operate simultaneously if a switch is used.

8.21.6 Ethernet/IP

AKD with connectivity option **EI** can be connected to an Ethernet/IP network via RJ-45 connector X11. The communication status is indicated by the built-in LEDs.

Connector	LED#	Name	Function
X11	LED1	IN port Link	ON = active, OFF = not active
	LED2	RUN	ON = running, OFF = not running

Connect the service interface (X11) of the drive to an Ethernet interface on the Ethernet/IP Master directly or via a network switch, **while the supply to the equipment is switched off**. Use standard Cat. 5 Ethernet cables for connection.

Confirm that the link LED on the AKD (the green LED on the RJ45 connector) and on your Master or Switch are both illuminated. If both lights are illuminated, then you have a good electrical connection.

The subnet mask of the AKD is 255.255.255.0. The first three octets of the drive's IP address must be the same as the first three octets of the HMI's IP address. The last octet must be different.

Ethernet/IP and WorkBench can operate simultaneously if a switch is used.

8.21.7 sercos® III

AKD drives (connection variant S3) can be connected as slaves to the sercos® III network via RJ-45 connectors X5 (in port) and X6 (out port). Line and ring topologies are possible. The communication status is indicated by the built-in connector LEDs.

NOTE

Available from firmware revision 1.11, the protocol works with Hypertherm masters only.

Connector	LED#	Name	Function
X5	LED1	IN port Link	ON = active, OFF = not active
	LED2	RUN	ON = running, OFF = not running
X6	LED3	OUT port Link	ON = active, OFF = not active
	LED4	-	-

9 Setup

9.1 Important Notes	182
9.2 SetupAKD-B, AKD-P, AKD-T	183
9.3 Setup AKD-M	189
9.4 Fault and Warning Messages	199
9.5 Troubleshooting the AKD	207

9.1 Important Notes

NOTE

Before testing and setup, the manufacturer of the machine must generate a risk assessment for the machine and take appropriate measures so that unforeseen movements cannot cause injury or damage to any person or property.

Only professional personnel with extensive knowledge in the fields of electrical engineering and drive technology are allowed to test and set up the drive.



DANGER

The equipment produces potentially lethal voltages up to 900 V. Risk of electrical shock. Check that all connection components that are live in operation are safely protected against bodily contact.

Never remove the electrical connections to the drive while it is live.

Capacitors can still have dangerous residual charges up to 7 minutes after switching off the supply voltage. Always measure the voltage in the DC bus link and wait until the voltage is below 50 V before handling components.



WARNING

The drive might restart automatically after power on, voltage dip or interruption of the supply voltage, depending on the parameter setting. Risk of death or serious injury for humans working in the machine. If parameter DRV.ENDEFAULT is set to 1, then place a warning sign to the machine (Warning: Automatic Restart at Power On) and ensure, that power on is not possible, while humans are in a dangerous zone of the machine.



CAUTION

The heat sink of the drive can reach temperatures up to 80°C in operation. Risk of light burns. Check the heat sink temperature before handling the drive. Wait until the heat sink has cooled down to 40 °C before touching it.

NOTICE

If the drive has been stored for more than 1 year, you must re-form the capacitors in the DC bus link circuit. Re-forming procedures are described in the Kollmorgen Developer Network ([Forming](#)).

NOTE

Additional information on setting up the equipment:

- Programming parameters and control loop behavior are described in the online help of the setup software.
- The setup of any expansion card described in the corresponding manual on the DVD.
- Kollmorgen can provide training courses for the drive upon request.

9.2 SetupAKD-B, AKD-P, AKD-T

9.2.1 Setup software WorkBench

This chapter describes the installation of the setup software WorkBench for AKD-B, AKD-P and AKD-T drives. WorkBench is not used for setting up the AKD-M (AKD PDMM), for this drive variant the KAS IDE software must be used (→ # 189).

Kollmorgen offers training and familiarization courses on request.

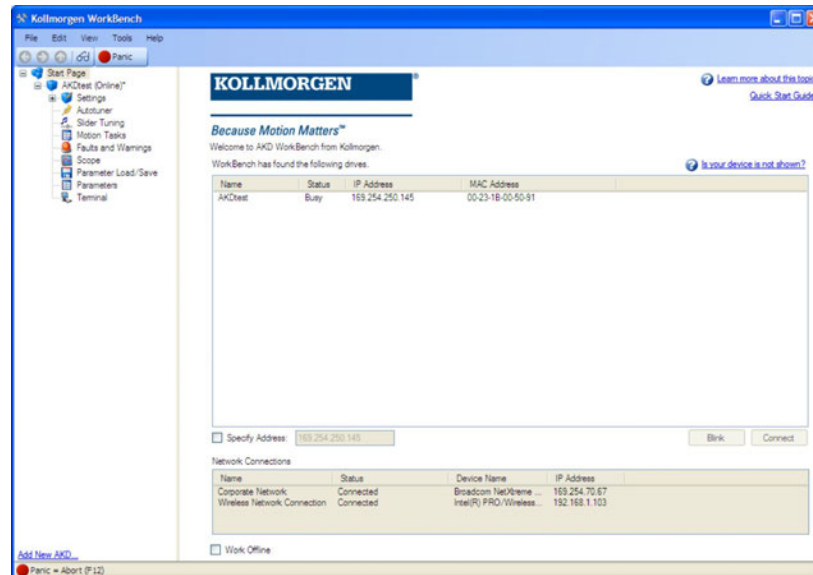

9.2.2 Use as directed

The setup software is intended to be used for altering and saving the operating parameters for the AKD series of drives. The attached drive can be set up with the help of this software, and during this procedure the drive can be controlled directly by the service functions.

Only professional personnel who have the relevant expertise (→ # 15) are permitted to carry out online parameter setting for a drive that is running.

Sets of data that have been stored on data media are not safe against unintended alteration by other persons. Unexpected move could be the result if you use unchecked data. After loading a set of data you must therefore always check all parameters before enabling the drive.

9.2.3 Software description

Each drive must be adapted to the requirements of your machine. For most applications, you can use a PC and WorkBench (the drive setup software) to set up the operating conditions and parameters for your drive. The PC is connected to the drive by an Ethernet cable (→ # 168). The setup software provides the communication between the PC and AKD. You can find the setup software on the accompanying DVD and in the download area of the Kollmorgen website.

With very little effort you can alter parameters and instantly observe the effect on the drive, since there is a continuous (online) connection to the drive. You can also read important actual values from the drive, which are displayed on the monitor of the PC (oscilloscope functions).

You can save sets of data on data media (archiving) and load them into other drives or use them for backup. You can also print out the data sets.

Most standard feedbacks (SFD, EnDAT 2.2, 2.1, and BiSS) are plug and play compatible. Motor nameplate data is stored in the feedback device and read by the drive automatically at startup. Non-plug and play Kollmorgen motors are stored in WorkBench and can be loaded with one-click using the Motor screen in the WorkBench software.

An extensive online help with integrated description of all variables and functions supports you in each situation.

9.2.4 Hardware requirements

The Service interface (X11, RJ45) of the drive is connected to the Ethernet interface of the PC by an Ethernet cable (→ # 168).

Minimum requirements for the PC:

Processor: at least Pentium® II or comparable

Graphics adapter : Windows compatible, color

Drives : hard disk with at least 20 MB free space, DVD drive

Interface : one free Ethernet Interface, or a Hub port or Switch port

9.2.5 Operating systems

Windows 2000/XP/VISTA/7/8

WorkBench works with Windows 2000, Windows XP, Windows VISTA, Windows 7 and Windows 8.

Unix, Linux

The functioning of the software has not been tested for Windows running with Unix or Linux.

9.2.6 Installation under Windows 2000/XP/VISTA/7

The DVD includes an installation program for the setup software.

Installation

- Autostart function activated:
Insert the DVD into a free drive. A window with the start screen opens. There you find a link to the setup software WorkBench. Click it and follow the instructions.
- Autostart function deactivated:
Insert the DVD into a free drive. Click **Start** (task bar), then **Run**. Enter the program call: `x:\index.htm` (x = correct DVD drive letter).
Click **OK** and proceed as described above.

Connection to the Ethernet interface of the PC

- Connect the interface cable to an Ethernet interface on your PC or to a Hub/Switch and to the service interface X11 of the AKD (→ # 168).

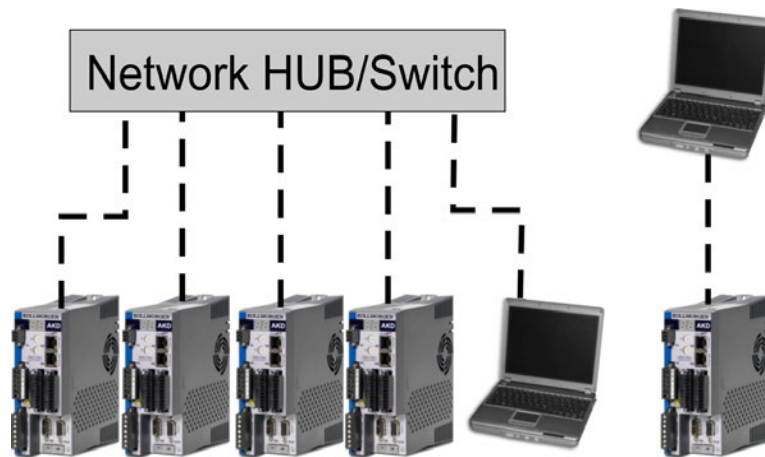

9.2.7 Initial Drive Test AKD-B, AKD-P, AKD-T

9.2.7.1 Unpacking, mounting, and wiring the AKD

- Unpack the drive and accessories. Observe the safety instructions in the documentation.
- Mount the drive.
- Wire the drive or apply the minimum wiring for drive testing as described below.
- Make sure you have on hand the following information about the drive components:
 - rated mains supply voltage
 - motor type (motor data, if the motor type is not listed in the motor database)
 - feedback unit built into the motor (type, poles/lines/protocol)
 - moment of inertia of the load

9.2.7.2 Minimum wiring for drive test without load

NOTICE

This wiring diagram is for general illustration only and does not fulfill any requirements for EMC, safety, or functionality of your application.

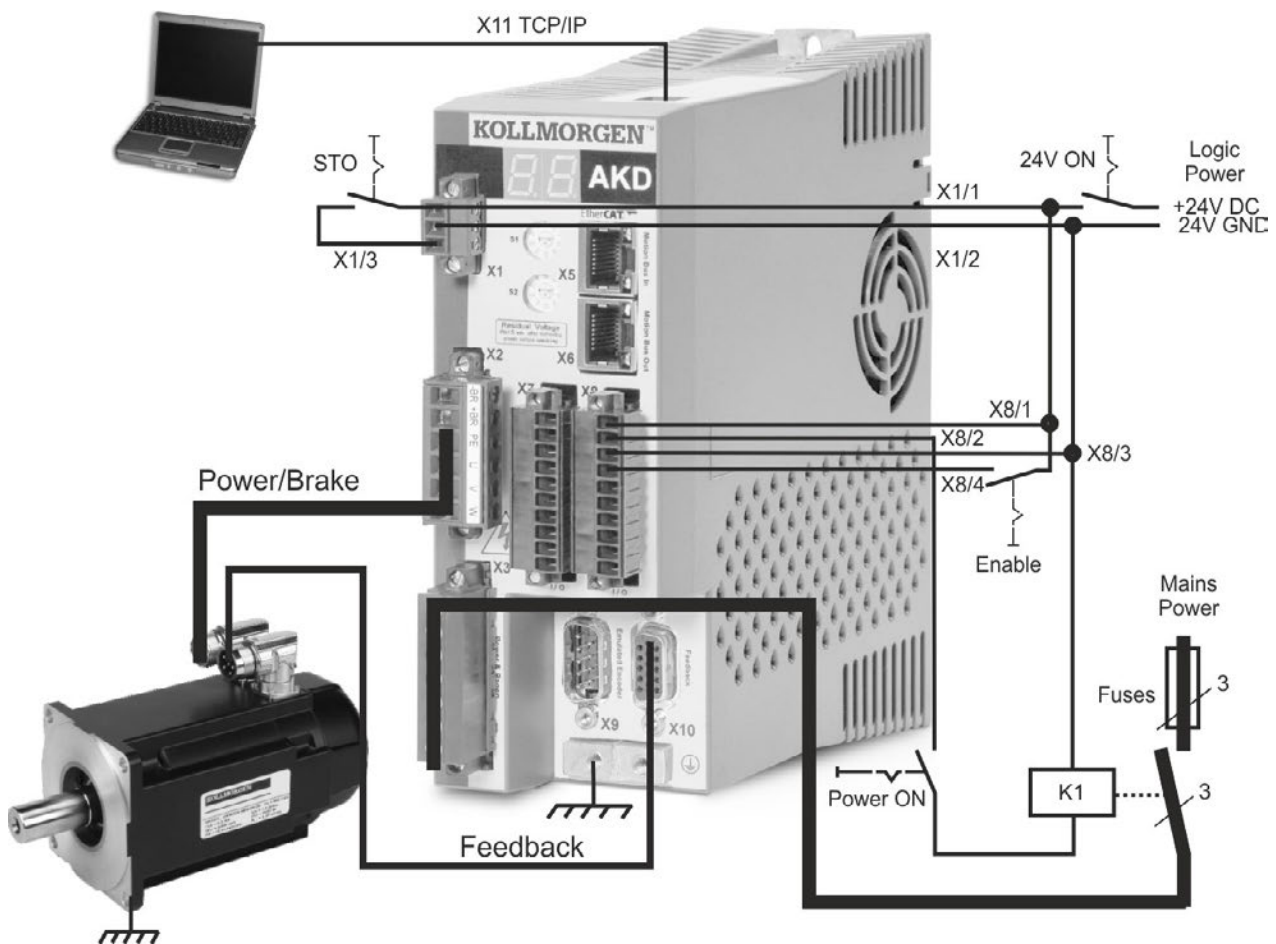

When connecting the AKD directly to a PC, static IP addressing (not 00) is recommended.

9.2.7.3 Set IP address

Set the drive IP address as described in (→ # 169).

9.2.7.4 Confirm connections

You can turn on logic power to the drive through the X1 connector (bus voltage is not needed for communications).

After power is supplied, the drive displays a sequence of LED flashes):

1. –
2. []
3.] [
4. I-P
5. Drive IP address, flashed sequentially (for example, 192.168.0.25).
6. Drive status (omode "o0", "o1", or "o2") or fault code if the drive is in a fault condition.

Confirm that the link LEDs on the drive (green LED on the RJ45 connector) and on your PC are both illuminated. If both LEDs are illuminated, then you have a working electrical connection.

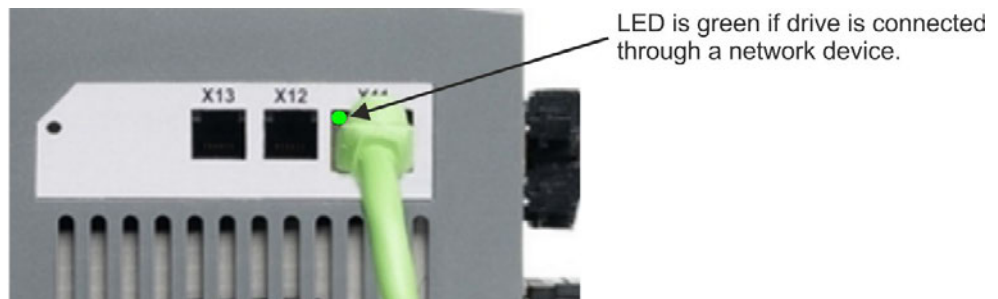

While the PC is connecting, your statusbar will show the following acquiring icon:

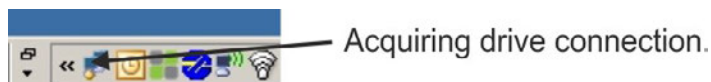

Wait for this icon to change to the limited functionality icon (this process can take up to one minute).



Although Windows displays this limited functionality icon for the drive connection, the PC can communicate fully with the drive. Using WorkBench, you can now configure the drive through this connection.

9.2.7.5 Install and start WorkBench

WorkBench installs automatically from the DVD included with the drive. WorkBench is also available on the Kollmorgen Web site: www.kollmorgen.com.

Once installation is complete, click the WorkBench icon to start the program. WorkBench will show a list of all the drives that it can find on your local network. Select the drive you wish to configure and then click **Next**.

If multiple drives are detected, a drive can be uniquely identified using one of the following methods:

1. The MAC address of the drive. This address is printed on the sticker on the side of the drive.
2. The name of the drive. The drive name is set using WorkBench. A new drive defaults to "No_Name."
3. Blinking the display. Select a drive and click **Blink** to force the display on the front of the drive to blink on and off for 20 seconds.

9.2.7.6 Set drive IP address in WorkBench

If WorkBench does not automatically show your drive, then you can set the IP address manually in WorkBench as follows:

1. Display the IP address. You can show the drive IP address on the drive display by pressing button B1. The display shows the digits and dots of the IP address in sequence (for example, 192.168.0.25).



2. Enter the drive IP address. Once the IP address has been determined, manually enter the drive IP address into the **Specify Address** box in WorkBench. Then click **Next** to connect.

9.2.7.7 Enable the drive using the setup wizard

Once a connection to the drive has been established, the AKD Overview screen appears. Your drive appears in the navigation area on the left of the screen. Right click on your drive name and select **Setup Wizard** from the drop-down menu. The Setup Wizard guides you through the initial drive configuration, which includes a simple test motion.

After completing the Setup Wizard, your drive should be enabled. If the drive is not enabled, check the following:

1. The hardware enable (HW) must be in the enabled state (pin 4 on X8 connector).
2. The software enable (SW) must be in the enabled state. Activate using the **Enable/Disable** button on the upper toolbar on WorkBench or in the Overview screen.
3. No faults may be present (click the **Clear Fault** button on the upper tool bar to clear any faults).

The status of HW enable, SW enable, and Faults is displayed in the lower toolbar of the WorkBench software. The drive is connected if the lower right corner shows **Online**.

You can now use the Settings View in WorkBench to complete advanced configuration of your drive.

9.3 Setup AKD-M

9.3.1 Setup software KAS IDE

This chapter describes the installation of the setup software KAS IDE for the AKD-M (AKD PDMM) drives. KAS IDE is not used for setting up the AKD-B, AKD-P and AKD-T drives, for these drive variants the WorkBench software must be used (→ # 183).

The KAS IDE integrated development environment contains tools for configuring the Ether-CAT Network, setup and tuning the drives, creating a PLC program, and creating an HMI. Kollmorgen offers training and familiarization courses on request.

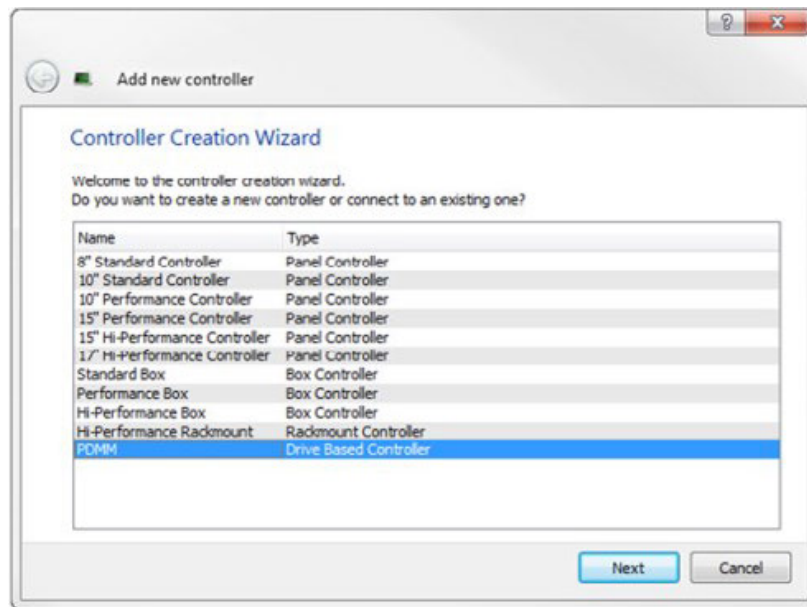

9.3.2 Use as directed

The setup software is intended to be used for altering and saving the operating parameters for the AKD PDMM series of drives. The attached drive can be set up with the help of this software, and during this procedure the drive can be controlled directly by the service functions.

Only professional personnel who have the relevant expertise (→ # 15) are permitted to carry out online parameter setting for a drive that is running.

Sets of data that have been stored on data media are not safe against unintended alteration by other persons. Unexpected move could be the result if you use unchecked data. After loading a set of data you must therefore always check all parameters before enabling the drive.

9.3.3 Software description

Each drive must be adapted to the requirements of your machine. For most applications, you can use a PC and KAS IDE software ("Kollmorgen Automation Suite Integrated development environment) to set up the operating conditions and parameters for your drive. The PC is connected to the drive by an Ethernet cable (→ # 168). The setup software provides the communication between the PC and AKD PDMM. You can find the KAS IDE setup software on the accompanying DVD and in the download area of the Kollmorgen website.

With very little effort you can alter parameters and instantly observe the effect on the drive, since there is a continuous (online) connection to the drive. You can also read important actual values from the drive, which are displayed on the monitor of the PC (oscilloscope functions).

You can save sets of data on data media (archiving) and load them into other drives or use them for backup. You can also print out the data sets.

Most standard feedbacks (SFD, EnDAT 2.2, 2.1, and BiSS) are plug and play compatible. Motor nameplate data is stored in the feedback device and read by the drive automatically at startup. Non-plug and play Kollmorgen motors are stored in KAS IDE and can be loaded with one-click using the Motor screen in the KAS IDE software.

An extensive online help with integrated description of all variables and functions supports you in each situation.

9.3.4 Hardware requirements

The Service interface (X32, RJ45) of the drive is connected to the Ethernet interface of the PC by an Ethernet cable (→ # 168).

Minimum requirements for the PC:

Processor: at least Pentium® II or higher

Operating system : Windows XP or 7

Graphics adapter : Windows compatible, color

Drives : hard disk with at least 20 MB free space, DVD drive

Interface : one free Ethernet Interface, or a Hub port or Switch port

9.3.5 Operating systems

Windows XP/7

KAS IDE works with Windows XP and Windows 7

Unix, Linux

The functioning of the software has not been tested for Windows running within Unix or Linux.

9.3.6 Installation under Windows XP/7

The DVD includes an installation program for the setup software.

Installation

- Autostart function activated:
Insert the DVD into a free drive. A window with the start screen opens. There you find a link to the setup software KAS IDE. Click it and follow the instructions.
- Autostart function deactivated:
Insert the DVD into a free drive. Click **Start** (task bar), then **Run**. Enter the program call: `x:\index.htm` (x = correct DVD drive letter).
Click **OK** and proceed as described above.

Connection to the Ethernet interface of the PC

- Connect the interface cable to an Ethernet interface on your PC or to a Hub/Switch and to the service interface X32 of the AKD PDMM (→ # 168).

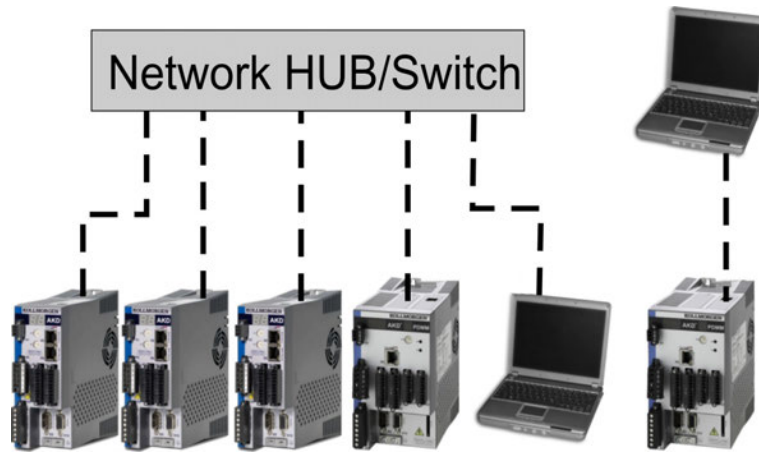

9.3.7 Initial Drive Test AKD-M

9.3.7.1 Unpacking, mounting, and wiring the AKD PDMM

- Unpack the drive and accessories. Observe the safety instructions in the documentation.
- Mount the drive.
- Wire the drive or apply the minimum wiring for drive testing as described below.
- Make sure you have on hand the following information about the drive components:
 - rated mains supply voltage
 - motor type (motor data, if the motor type is not listed in the motor database)
 - feedback unit built into the motor (type, poles/lines/protocol)
 - moment of inertia of the load

9.3.7.2 Minimum wiring for drive test without load

NOTICE

This wiring diagram is for general illustration only and does not fulfill any requirements for EMC, safety, or functionality of your application.

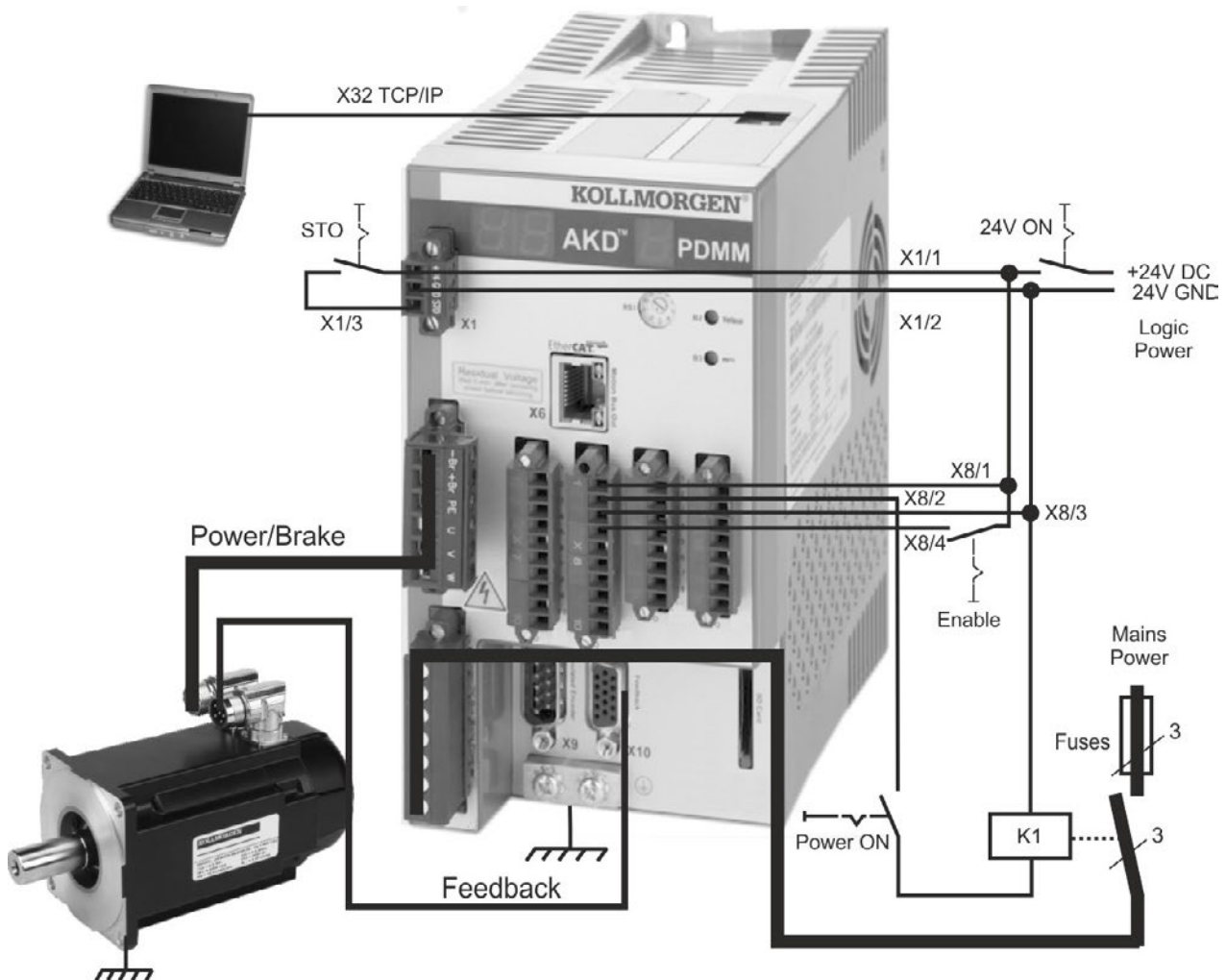

When connecting the AKD PDMM directly to a PC, static IP addressing (not 0) is recommended.

9.3.7.3 Set IP address

Set the drive IP address as described in (→ # 171).

9.3.7.4 Confirm connections

You can turn on logic power to the drive through the X1 connector (bus voltage is not needed for communications).

After power is supplied, the drive displays a sequence of LED flashes:

AKD-M two + one digits	
	
<ul style="list-style-type: none"> - - Power on o# Drive opmode # not enabled o#. Drive opmode # enabled <p>see WorkBench Onlinehelp for details.</p>	<ul style="list-style-type: none"> - Power on - to O Initialization sequence IP_ IP address o Operational - program not running o. Operational - program running

Confirm that the link LEDs on the drive (green LED on the RJ45 connector X32) and on your PC are both illuminated. If both LEDs are illuminated, then you have a working electrical connection.



LED is green if drive is connectec through a network device.

While the PC is connecting, your statusbar will show the following acquiring icon:



Acquiring drive connection.

Wait for this icon to change to the limited functionality icon (this process can take up to one minute).

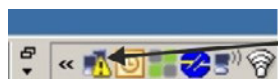

Drive connection complete.

Although Windows displays this limited functionality icon for the drive connection, the PC can communicate fully with the drive. Using KAS IDE, you can now configure the drive through this connection.

9.3.7.5 Install and start KAS IDE

The KAS IDE is included on the DVD that came with the AKD PDMM, as well as online at www.kollmorgen.com. Insert the DVD and wait for installer to auto-start. Once installation is complete, click the KAS IDE icon to start the program.

Begin a new project by selecting **File > New**. This will launch the **Add a New Controller** window. Select your AKD PDMM model from the list. The controller will then be added to the project view.

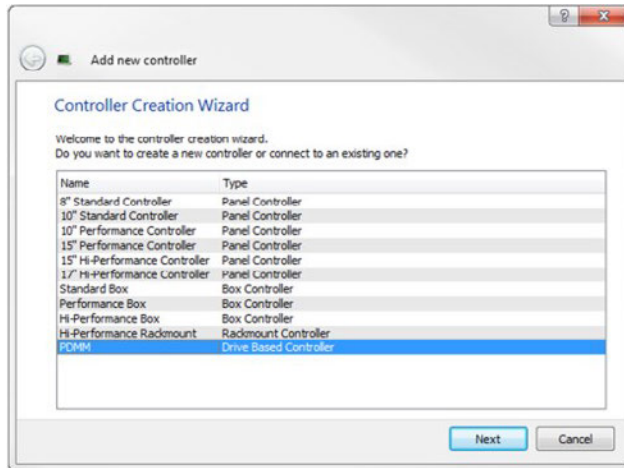

To associate the project with an IP address of the AKD PDMM controller, right click on the Controller option in the Project View. Select **Properties** and the following screen appears:

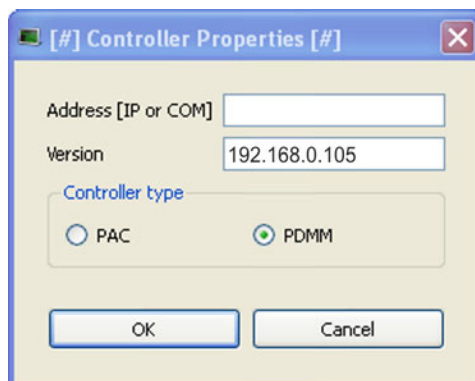

Type in the IP address of the AKD PDMM, set the **Controller Type** to PDMM and click OK. To connect to the PDMM, download, and run the project use the following controls:

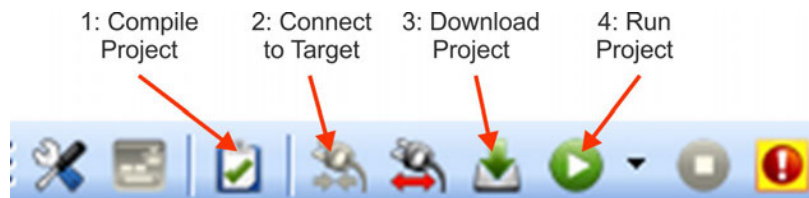

Double click on EtherCAT in the project view to open the EtherCAT devices view. Click on scan devices in the upper-right corner, and the KAS IDE will automatically identify and add your drive.

If multiple drives are detected, a drive can be uniquely identified using one of the following methods:

1. The MAC address of the drive. This is printed on the sticker on the side of the drive.
2. The name of the drive. The drive name is set using KAS IDE. A new drive defaults to "No_Name."
3. Blinking the display. Select a drive and click Blink to force the display on the front of the drive to blink on and off for 20 seconds.

9.3.7.6 Set drive IP address in KAS IDE

If KAS IDE does not automatically show your drive, then you can set the IP address manually in KAS IDE as follows:

1. Display the IP address. You can show the drive IP address on the drive display by starting the menu with button B2 and selecting "IP" by pressing B2 again. The display shows the digits and dots of the IP address in sequence (for example, 192.168.0.105).
2. The IP address of the AKD PDMM is setup in the project file inside the KAS IDE. To see the IP address, open a project or create a new project. Right click on the Project Explorer-/Project view Controller item and select **Properties**.

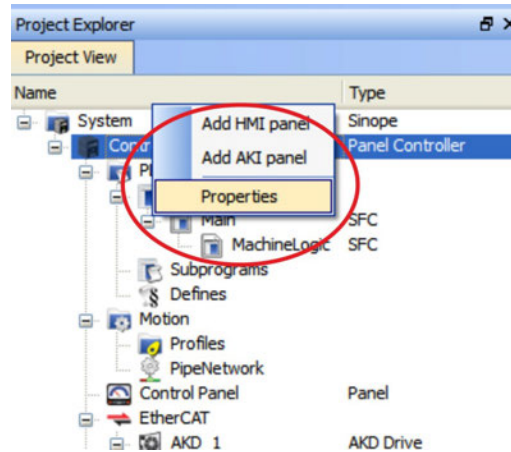

3. Type in the AKD PDMM address as follows:

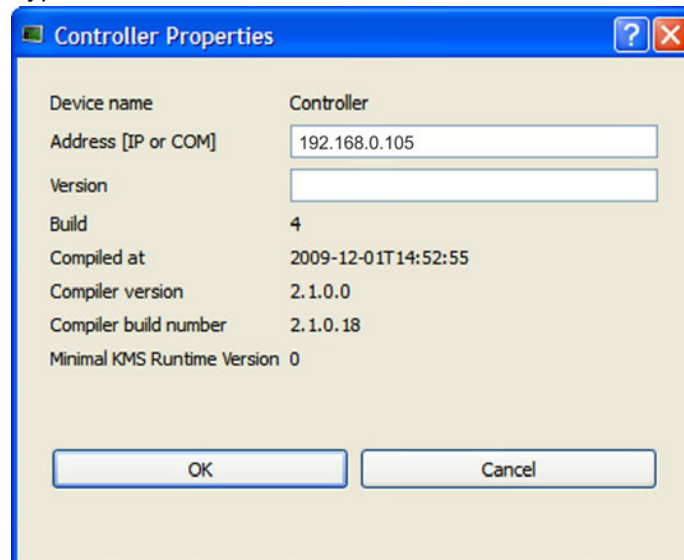

9.3.7.7 Starting new project

Once a project (new or saved) is opened from the Project Explorer, you can open a variety of items to build a project:

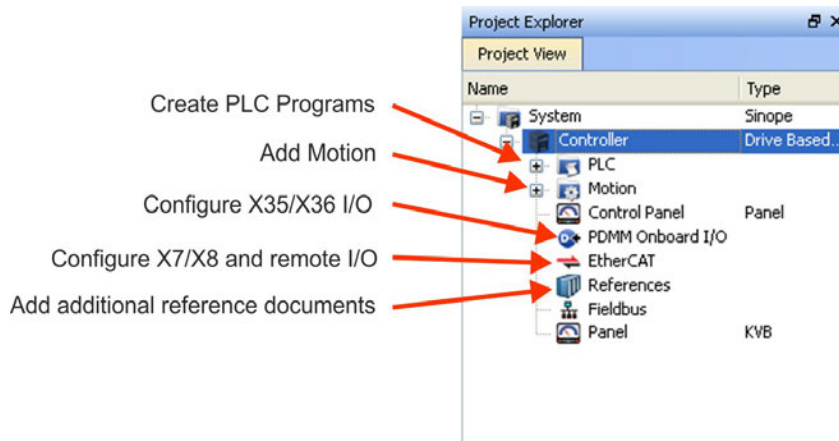

All drives, including the drive in the AKD PDMM itself, and the Remote I/O can be configured by the KAS IDE.

Add the drives to the project: click on the EtherCAT item and scan for devices (1).

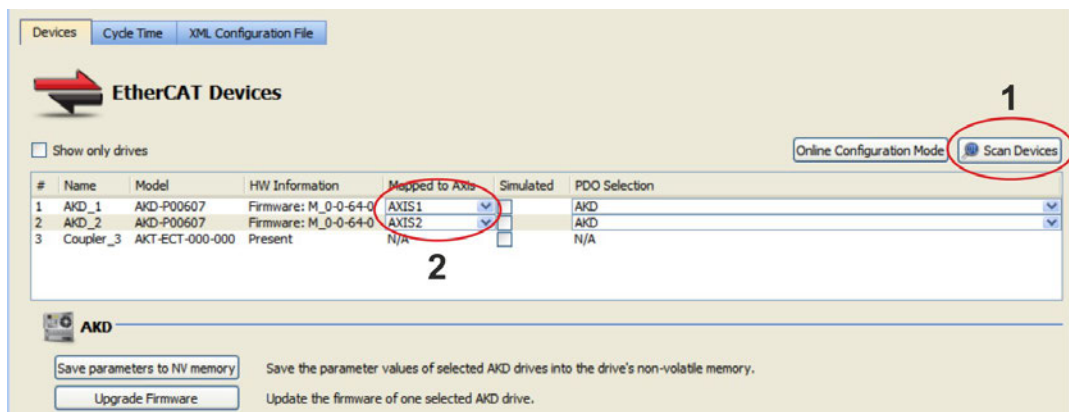

Map the detected drives to axis of your application (2). All detected items are automatically added to your project:

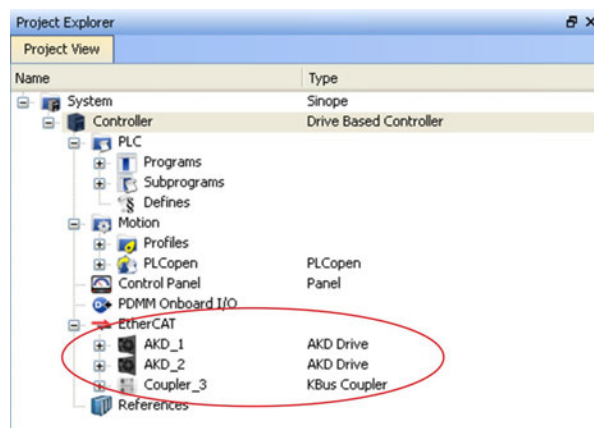

To communicate directly with a drive without running a project click on the EtherCAT item in the project tree. Click on the drive in the project tree to configure (1), then click on the **Online Configuration** button (2):

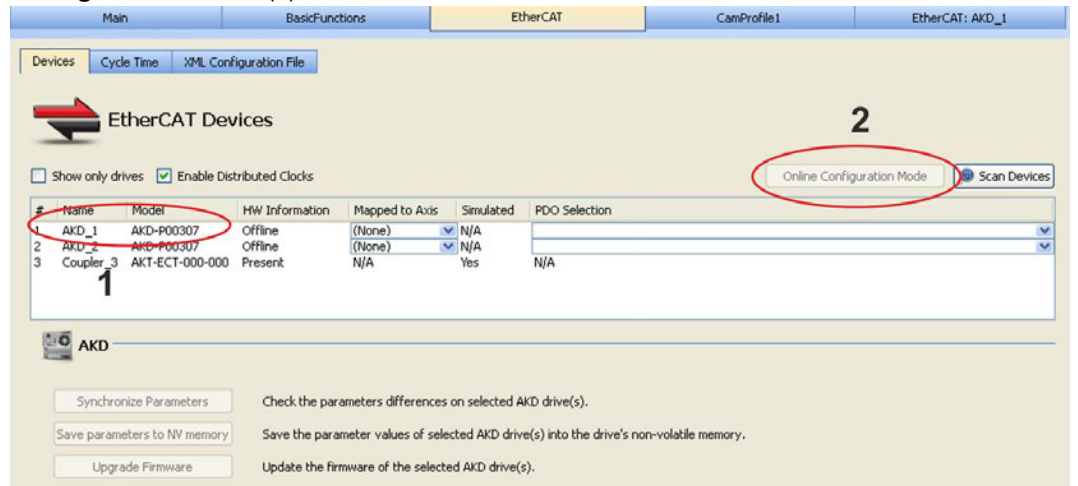

In the work space a set of screens opens up that enable you to completely configure the drive:

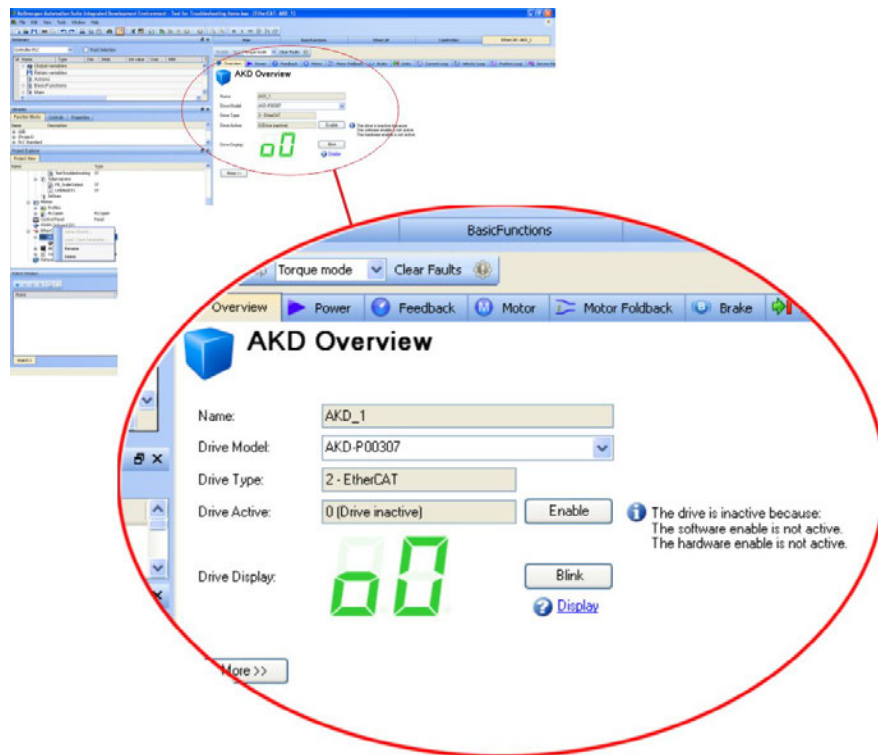

Additionally the setup wizard will take you through a set of steps to perform the configuration:

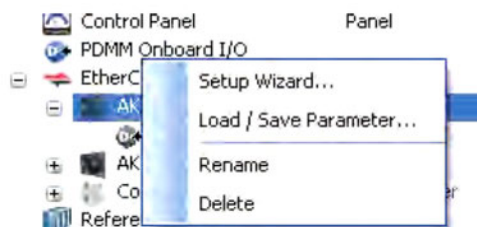

To perform basic motion without running a project the **Service Motion** screen can be used.

The screenshot displays the 'Service Motion' control interface. At the top, there are buttons for 'Enable', 'Stop', 'Position mode', and 'Clear Faults'. Below this is a navigation bar with tabs for 'Limits', 'Current Loop', 'Velocity Loop', 'Position Loop', and 'Service Motion'. The main area features a purple waveform icon and the title 'Service Motion'. A text box explains: 'Service motion allows you to start and stop some test motions.' Below this, the 'Service Motion Mode' is set to 'Pulse' (selected), with 'Reversing' and 'Continuous' as options. A velocity profile graph shows a trapezoidal pulse starting at 0 rpm, reaching a peak of 60,000 rpm, and returning to 0 rpm. The duration of the pulse is labeled 'Time 1: 500 ms'. Below the graph, 'Acceleration' and 'Deceleration' are both set to 10,000.170 rpm/s. A 'Start' button is present, accompanied by a warning icon and the text 'Drive is inactive.'. Feedback data shows 'Position Feedback: -56,970.640 Counts16Bit' and 'Velocity Feedback: 0.000 rpm'. At the bottom, a status bar shows 'No Faults' (green), 'Drive Inactive' (red), 'SW' (red), 'HW' (red), and 'Not Connected'.

9.4 Fault and Warning Messages

9.4.1 Fault and warning messages AKD

When a fault occurs, the drive fault relay is opened, the output stage is switched off (motor loses all torque), or the load is dynamically braked. The specific drive behavior depends on the type of fault. The LED display on the front panel of the drive shows the number of the fault that occurred. If a warning is issued prior to the fault, the warning is shown on the LED and has the same number as the associated fault. Warnings do not trip the power stage of the drive or fault relay output.



AKD fault codes or warning codes are displayed constantly if present. Fault messages are coded with "F", warnings are coded with "n". With built-in I/O option card, SD card operation errors are displayed with "E" followed by 4 digits.

The left side of the LED displays F (or E) for a fault or n for a warning. The right side displays the fault or warning number as follows: 1-0-1-[break]. The highest priority fault is displayed. Multiple faults may be present when a fault condition is occurring. Check the AKD WorkBench Fault Screen or read the status of DRV.FAULTS through the controller or HMI for the entire list of faults.

NOTE

More information about fault messages, remedy and clearing faults can be found in the WorkBench online help.

Code	Message/Warning
..	24V power (X1) overload or 5V (X9) shorted
E0082	SD Card is not inserted.
E0083	SD Card is write protected.
E0084	SD Card hardware not installed.
E0095	File not found on SD Card.
E0096	File error trying to access the SD Card.
E0097	File system error accessing the SD card.
E0098	A parameter could not be set in the drive.
E0099	There was an error writing to a file on the SD Card.
E0100	SD Card read/write in progress.
E0101	There was an error accessing the BASIC binary file.
F0	Reserved.
F101, n101	Firmware incompatible. The FPGA is a lab FPGA.
F102, n102	Resident firmware failed. Operational FPGA is not a default FPGA.
F103	Resident FPGA failed.
F104	Operational FPGA failed.
F105	Non-volatile memory stamp invalid.
F106	Non-volatile memory data
n107	Positive limit switch exceeded.
n108	Negative limit switch exceeded.
F121	Homing error.
F123, n123	Invalid motion task.
F125, n125	Synchronization lost.
F126, n126	Too much movement.
F128	MPOLES/FPOLES not an integer.
F129	Heartbeat lost.

Code	Message/Warning
F130	Secondary feedback supply over current.
F131	Secondary feedback A/B line break.
F132	Secondary feedback Z line break.
F133	Fault number changed to F138.
F134	Secondary feedback illegal state.
F135, n135	Homing is needed.
F136	Firmware and FPGA versions are not compatible
n137	Homing and feedback mismatch
F138	Instability during autotune
F139	Target Position Overshot due to invalid Motion task activation.
n151	Not enough distance to move; motion exception.
n152	Not enough distance to move; following motion exception.
n153	Velocity limit violation, exceeding max limit.
n154	Following motion failed; check motion parameters.
n156	Target position crossed due to stop command.
n157	Homing index pulse not found.
n158	Homing reference switch not found.
n159	Failed to set motion task parameters
n160	Motion task activation failed.
n161	Homing procedure failed.
n163	MT.NUM exceeds limit.
n164	Motion task is not initialized.
n165	Motion task target position is out.
n167	SW limit switch traversed
n168	Invalid bit combination in the motion task control word.
n169	1:1 profile cannot be triggered on the fly.
n170	Customer profile table is not initialized.
n171	Motion task activation is currently pending
n174	Homing maximum distance exceeded
F201	Internal RAM failed.
F202	External RAM failed.
F203	Code integrity failed.
F204 to F232	EEPROM failure detected
F234 to F237	(n234 to n237) Temperature sensor high.
F240 to F243	(n240 to n243) Temperature sensor low.
F245	External fault.
F247	Bus voltage exceed allowed thresholds.
F248	Option board EEPROM corrupted.
F249	Option board downstream checksum.
F250	Option board upstream checksum.
F251	Option board watchdog.
F252	Firmware and option board FPGA types are not compatible.
F253	Firmware and option board FPGA versions are not compatible.
F256, n256	Analog Input, voltage treshold exceeded
F257, n257	Analog Input, voltage treshold underrun

Code	Message/Warning
F301, n301	Motor overheated.
F302	Over speed.
F303	Runaway.
F304, n304	Motor foldback.
F305	Brake open circuit.
F306	Brake short circuit.
F307	Brake closed during enable state.
F308	Voltage exceeds motor rating.
n309	Motor I ² t load.
F312	Brake released when it should be applied.
F401	Failed to set feedback type.
F402	Analog signal amplitude fault.
F403	EnDat communication fault.
F404	Hall error.
F405	BiSS watchdog fault.
F406	BiSS multicycle fault.
F407	BiSS sensor fault.
F408 to F416	SFD feedback fault.
F417	Broken wire in primary feedback.
F418	Primary feedback power supply.
F419	Encoder init procedure failed
F420	FB3 EnDat Communications Fault.
F421	SFD position sensor fault
F423	NV Failure - Extended Multiturn
F436	EnDat overheated.
F438, n438	Following error (numeric)
F439, n439	Following error (user).
F450	Following error (presentation).
F451, n451	Tamagawa encoder: battery.
F452	Extended multiturn not supported with this feedback.
F453 to F459	Tamagawa encoder: communication.
F460	Tamagawa encoder: over speed.
F461	Tamagawa encoder: counting Error.
F462	Tamagawa encoder: counting overflow.
F463	Tamagawa encoder: overheat.
F464	Tamagawa encoder: multiturn error.
F465	Excessive shock detected by feedback device.
F467	Feedback fault on feedback 1. In case of BiSS: communications.
F468	FB2.SOURCE not set, Remote Commutation not possible.
F469	FB1.ENCRE is not power of two, Remote Commutation not possible.
F470	Feedback fault on feedback 3.
F473	Wake and Shake. Insufficient movement
F475	Wake and Shake. Excess movement.
F476	Wake and Shake. Fine-coarse delta too large.
F478, n478	Wake and Shake. Overspeed.

Code	Message/Warning
F479	Wake and Shake. Loop angle delta too large.
F480	Fieldbus command velocity too high.
F481	Fieldbus command velocity too low.
F482	Commutation not initialized.
F483	Motor U phase missing.
F484	Motor V phase missing.
F485	Motor W phase missing.
F486	Input change rate exceeds maximum EMU speed.
F487	Wake & Shake - Validating Positive Movement Failed.
F489	Wake & Shake - Validating Negative Movement Failed.
F490	Wake & Shake - Validating Comm. angle timed out.
F491	Wake & Shake - Validat. Comm. angle moved too far - Bad Comm Angle.
F492	Wake & Shake - Validat. Comm. angle required more than MOTOR.ICONT.
F493	Invalid commutation detected – motor accelerating in the wrong direction.
F501, n501	Bus over voltage.
F502	Bus under voltage. Warning issued prior to fault.
F503, n503	Bus capacitor overload.
F504 to F518	Internal supply voltage fault
F519	Regen short circuit.
F521, n521	Regen over power.
F523	Bus over voltage FPGA
F524, n524	Drive foldback.
F525	Output over current.
F526	Current sensor short circuit.
F529	Iu current offset limit exceeded.
F530	Iv current offset limit exceeded.
F531	Power stage fault.
F532	Drive motor parameters setup incomplete.
F534	Failed to read motor parameters from feedback device.
F535	Power-board over-temperature fail.
F536	Standby power supply fault.
F537	Precharge fault.
F560	Regen near capacity, could not prevent over voltage.
F570	Mains phase loss.
n580	Using derivate of position with sensorless feedback type in position mode.
n581	Zero velocity with induction sensorless feedback type in position mode.
n582	Velocity has been limited, commutation frequency max. 599 Hz to meet ECCN-3A225 / AL-3A225 limits.
n601	Modbus data rate is too high.
F602	Safe torque off.
n603	OPMODE incompatible with CMDSOURCE
n604	EMUEMODE incompatible with DRV.HANDWHEELSRC.
F621	Control Board CRC fault.
F623	Power Board CRC fault.
F624	Power Board Watchdog fault.

Code	Message/Warning
F625	Power Board Communication fault.
F626	Power Board FPGA not configured.
F627	Control Board Watchdog fault.
F630	FPGA cyclic read fault.
F701	Fieldbus runtime.
F702, n702	Fieldbus communication lost.
F703	Emergency timeout occurred while axis should disable.

9.4.2 Additional fault messages AKD-T

AKD BASIC runtime faults are displayed in the two-digits 7-segment display of the drive:

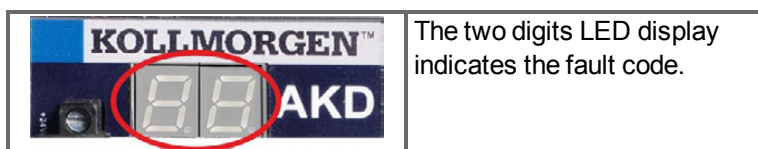

The additional runtime fault messages for AKD-T are coded with numbers starting from F801. All faults activate the fault relay and can be cleared with `DRV.CLRFAULTS`.

NOTE

More information about error messages, causes, remedy and clearing errors can be found in the WorkBench online help.

Remedy for all errors: clear error, fix user program, recompile, download and attempt to run the program again.

Error	Description
F801	Divide by zero.
F802	Stack Overflow.
F803	Insufficient Memory.
F804	No interrupt handler defined.
F805	Interrupt error.
F806	Max string length exceeded.
F807	String overflow.
F808	Array out of bounds.
F809	Feature not supported.
F810	Internal firmware/hardware error.
F812	Parameter not supported.
F813	Parameter access error.
F814	Data not found.
F815	Data invalid.
F816	Data too high.
F817	Data too low.
F818	Param type out of range.
F819	Data not divisible by 2.
F820	Invalid position modulo setting.
F821	Cannot read from command.
F823	Enable Drive first.
F824	DRV.OPMODE must be 2 (position).
F825	DRV.CMDSOURCE must be 5 (program).
F826	Cannot execute during a move.
F827	Writing to read-only parameter.
F828	Disable Drive first.
F829	Opcode not supported - upgrade firmware.
F830	No negative values allowed.
F831	BASIC program is invalid. May need firmware upgrade.
F832	BASIC program is missing.
F901	Too many cams.

9.4.3 Additional error and alarm messages AKD-M

Faults/Errors and Warnings/Alerts are displayed in the 7 segment displays of the drive:

AKD two digits	AKD-M two + one digits
	
<p>The two digits LED display indicates the drive messages. Drive fault messages are coded with "F", warnings are coded with "n" and are described in (→ # 199)</p>	<p>The one digit LED indicates the PDMM messages of the AKD PDMM. Error messages are coded with "E", alarms are coded with "A" and are described in the chapter below.</p>

To simplify handling, the error and alarm handling process is consistent, so you can always apply the same recovery steps. When an error or alarm occurs, it is displayed to the one digit display, you can identify the error in the table below and follow the recommendations to fix the problem, clear the display, and resume machine operation.

Active errors and alarms can be cleared with the controller command **ClearCtrlErrors**, (Note: non-clearable errors will remain).

9.4.3.1 Alarms

Alarm	Description
A01	High temperature exceeded
A02	Low on memory.
A04	Low input voltage
A12	Flash memory is low on free space.
A21	Recoverable process or thread failed to respond during operation.
A23	CPU is overloaded
A30	EtherCAT missed a send frame during operation mode.
A38	EtherCAT missed a receive frame during operation mode.
A40	Local digital IO missed a cyclic update
A53	AKD-M-MC was replaced with the higher performance M1 model.

9.4.3.2 Errors

When an Error or Alarm occurs, always check the controller log messages. The log messages will provide more details about the failure and the history of events leading up to the failure. From the log messages, you can determine the specifics about the cause of the failure to correct the underlying problem.

NOTE

More information about error and alarm messages, causes, remedy and clearing errors can be found in the WorkBench online help.

Error	Description
E01	Critical temperature exceeded. PDMM operation is stopped, CPU will be put to sleep.
E02	Out of memory. KAS runtime is stopping.
E03	Fan failure.
E10	Firmware is corrupted.
E11	Flash is corrupted, no filesystem is available.
E12	Not enough flash memory available.
E13	Out of NVRAM space for retained variables.
E14	Reset to Factory Defaults failed.
E15	Cannot read/write files from/to a SD card.
E16	Not enough space available on the SD card.
E20	Runtime plug-in, process, thread or application failed to start.
E21	Runtime plug-in, process, or thread failed to respond during operation.
E22	Fatal error in PLC program, application stopped.
E23	CPU is overloaded.
E24	PLC application cannot be started
E30	EtherCAT communication failure during operational mode.
E31	EtherCAT communication failure during preop mode.
E32	EtherCAT communication failure during bootstrap mode.
E33	EtherCAT failed to initialize into operational mode.
E34	EtherCAT failed to initialize into preop mode.
E35	EtherCAT failed to initialize into bootstrap mode.
E36	EtherCAT network discovery failed.
E37	EtherCAT failed to return to init state.
E50	Backup to SD card failed.
E51	Restore from SD card failed..
E52	SD Backup files are missing or corrupt.
E53	SD Backup files are not compatible.

9.5 Troubleshooting the AKD

Drive problems occur for a variety of reasons, depending on the conditions in your installation. The causes of faults in multi-axis systems can be especially complex. If you cannot resolve a fault or other issue using the troubleshooting guidance presented below, customer support can give you further assistance.

NOTE More details on the removal of faults can be found in the WorkBench online help.

Problem	Possible Causes	Remedy
HMI message: Communication fault	<ul style="list-style-type: none"> wrong cable used, cable plugged into wrong position on drive or PC wrong PC interface selected 	<ul style="list-style-type: none"> plug cable into the correct sockets on the drive and PC select correct interface
Drive does not enable	<ul style="list-style-type: none"> HW Enable not wired HW or SW Enable not set 	<ul style="list-style-type: none"> connect HW Enable (X8 pin 4) Apply 24V to HW Enable and select SW Enable in WorkBench / Fieldbus
Motor does not rotate	<ul style="list-style-type: none"> drive not enabled software enable not set break in setpoint cable motor phases swapped brake not released drive is mechanically blocked motor pole no. set incorrectly feedback set up incorrectly 	<ul style="list-style-type: none"> apply ENABLE signal set software enable check setpoint cable correct motor phase sequence check brake control check mechanics set motor pole no. set up feedback correctly
Motor oscillates	<ul style="list-style-type: none"> gain is too high (speed controller) feedback cable shielding broken AGND not wired up 	<ul style="list-style-type: none"> reduce VL.KP (speed controller) replace feedback cable join AGND to CNC-GND
Drive reports following error	<ul style="list-style-type: none"> I_{rms} or I_{peak} set too low current or velocity limits apply accel/decel ramp is too long 	<ul style="list-style-type: none"> verify motor/drive sizing verify that IL.LIMITN/P, VL.LIMITN/P are not limiting the drive reduce DRV.ACC/DRV.DEC
Motor overheating	<ul style="list-style-type: none"> motor operating above its rating motor current settings incorrect 	<ul style="list-style-type: none"> verify motor/drive sizing verify motor continuous and peak current values are set correctly
Drive too soft	<ul style="list-style-type: none"> K_p (speed controller) too low K_i (speed controller) too low filters set too high 	<ul style="list-style-type: none"> increase VL.KP (speed controller) increase VL.KI (speed controller) refer to documentation regarding reducing filtering (VL.AR*)
Drive runs roughly	<ul style="list-style-type: none"> K_p (speed controller) too high K_i (speed controller) too high filters set too low 	<ul style="list-style-type: none"> reduce VL.KP (speed controller) reduce VL.KI (speed controller) refer to documentation regarding increasing filtering (VL.AR*)
During installation, the message "Please wait while the installer finishes determining your disk space requirements" appears and never disappears.	<ul style="list-style-type: none"> MSI installer issue. Harddisk space not sufficient 	<ul style="list-style-type: none"> Cancel the installation and relaunch the installer (you may need to try several times, the problem is random). Make sure that you have enough disk space on your hard disk (~500MB).

-- / --

10 Index

A

Abbreviations	12
AKD Family	31
Ambient temperature	33
Analog inputs	148
Analog setpoints	148
Aux. supply 24V, interface	103

B

BISS encoder	126
---------------------------	-----

C

Cabinet Assembly	
Extended Width	71
Standard Width	67
Cable and Wire Requirements	40
CANbus	
Baud rate	174
Cable	175
CANopen interface	172
Node address	175
Termination	175
Capacitor Modules	110
Comcoder interface	133
Conformance	
CE	24
EAC	26
REACH	25
RoHS	25
Safety (STO)	26
UL, cUL	22
Connection Diagrams	
B, P, T Variants	82
M variants	90
Connection Overview	
B, P, T Variants	81
M Variants	89
Connector Assignments	
B, P, T Variants	81
M Variants	89
Connectors	39
CW/CCW Input	141

D

DC Bus Capacitance	42
DC bus link, interface	106
Diagnostic Cover Ratio	62
Dig. Encoder emulation, interface	142

Digital inputs

all Variants	150
I/O option	153
M Variant	155

Dimensions

Extended Width	73
Standard Width	69

Disposal

.....	20
-------	----

Document Revisions

.....	213
-------	-----

DSL

.....	125
-------	-----

Dynamic Braking

.....	41
-------	----

E

EAC

.....	26
-------	----

Emergency Off

.....	51
-------	----

Emergency Stop Function

.....	51
-------	----

Emulated Encoder Connector

.....	136
-------	-----

Emulated Encoder Output

.....	142
-------	-----

ENABLE

.....	152
-------	-----

Enclosure protection

.....	33
-------	----

EnDat 2.1 encoder interface

.....	128
-------	-----

EnDat 2.2 encoder interface

.....	129
-------	-----

EtherCAT

.....	178
-------	-----

EtherNet

EtherCAT Protocol	178
-------------------------	-----

Ethernet/IP Protocol	179
----------------------------	-----

Modbus TCP Protocol	172
---------------------------	-----

PROFINET RT Protocol	179
----------------------------	-----

sercos® III Protocol	180
----------------------------	-----

SynqNet Protocol	179
------------------------	-----

Ethernet/IP

.....	179
-------	-----

F

Fault messages

.....	199
-------	-----

FAULT relay

.....	158
-------	-----

Feedback

.....	119
-------	-----

Feedback Connection

.....	120
-------	-----

Fusing

.....	38
-------	----

G

Grounding

.....	77
-------	----

Grounding Plates

.....	100
-------	-----

H

Hall Sensoren

.....	134
-------	-----

Hardware requirements

KAS IDE	190
---------------	-----

WorkBench	184
-----------------	-----

Hiperface DSL

.....	125
-------	-----

Hiperface encoder interface

.....	131
-------	-----

Humidity

in operation	33
--------------------	----

Storage	19
---------------	----

Transport	19	Outputs	
I		Analog	149
I/O-Connection	144	Basic Data	34
Initial Drive Test		Digital all Variants	157
B,P,T Variants	186	Digital M Variant	161
M Variants	192	Digital, I/O option	159
Inputs		Fault Relay	158
Analog	148	Relay, I/O option	160
Basic Data	34	P	
Digital all Variants	150	Package supplied	28
Digital M Variant	155	Packaging	19
Digital, I/O option	153	Part number scheme	29
Enable	152	PC connection	168
Programmable	151, 153	Pollution level	33
STO	53	PROFINET	179
Installation		Prohibited Use	
Electrical	75	General	18
Mechanical	66	STO	55
Software KAS IDE	191	Pulse Direction, interface	140
Software WorkBench	185	Pushbuttons	164
IP Address		R	
B, P, T Variants	169	Re-forming	182
M Variant	171	REACH	25
K		Regen circuit	41
KAS IDE	189	Regen resistor, interface	108
KCM	110	Relay Output, I/O option	160
L		Repair	20
Leakage current	64	Resolver interface	122
M		ROD 5V with Hall interface	133
Mains supply, interface	104	RoHS	25
Maintenance	20	S	
Marquages UL	22	Safe Torque Off (STO)	53
Master-Slave	143	Safety	14
Modbus	172	Safety Instructions	
Motor-holding brake	116	Electrical Installation	76
Motor interface	114	General	15
Motor Power Connection	114	Mechanical Installation	66
Mounting position	33	Setup	182
N		STO	54
Nameplate	28	sercos® III	180
Noise Emission	33	Service Interface	168
O		Setup	182
Operating systems		B, P, T variants	183
KAS IDE	190	M variants	189
WorkBench	184	Setup Software	
		KAS IDE	189
		WorkBench	183
		SFD	123
		SFD3	124
		Shield connection	98
		Shielding	77

Shock-hazard protection	64
SinCos encoder with Hall	132
Site	66
Site altitude	33
Stacking height	19
Stacking Height, Storage	19
Standards	25
Standards used	13
STO	53
Stop Function	51
Storage	19
Supply networks	101
Switch-on/switch-off behavior	44
Symbols used	11
SynqNet	179
System components, overview	79

T

Temperature	
in operation	33
Storage	19
Transport	19
Tightening torques, connectors	37
Transport	19
Trouble Shooting	207

U

UL Markings	22
Uninstalling	20
Use as directed	
Drive	17
KAS IDE Setup Software	189
STO	55
WorkBench Setup Software	183

V

Ventilation	
Ambient Conditions	33
Mechanical Installation	66
Vibrations	33

W

Warnings	199
Wiring	78

-- / --

11 Record of document revisions

Revision	Remarks
- , 11/2009	Beta launch version
- , 12/2009	Digital I/O corrections, several updates
A, 03/2010	CAN termination connector "optional", data dynamic brake updated, resolver signals renamed, CE certificate, X9 description updated, technical data completed
B, 06/2010	Several updates, typos, dimensions corrected, switch on/off timing diagrams
C, 07/2010	Switch on/off timing diagrams, typos, cover layout
D, 01/2011	Hardware Revision C, STO certified, voltage level digital inputs changed
E, 04/2011	Analog In/Out specification extended, single-/two phase mains supply updated
F, 10/2011	PROFINET RT, Modbus TCP, several updates, cover layout updated
G, 03/2012	AKD PDMM added, 270 VAC mains supply restriction removed, part number scheme extended, EnDat 2.2 @ X9, STOP chapter updated, dimension drawings
H, 05/2012	AKD-T-IC added, I/O option card signals added , PDMM error codes updated
J, 08/2012	Smart Abs (Tamagawa) new, BiSS C new, X21 & X22 pinout updated
K, 11/2012	Feedback wiring diagrams updated, font size hint, fault tables updated, regen fusing
L, 05/2013	Hiperface DSL Feedback new (from FW 1.9), fault tables updated, KCM module added
M, 09/2013	24A AKD-M added, fault tables update, outer dimensions updated
N, 12/2013	sercos [®] III option added, SFD3 feedback added, sincos frequency limit, automatic restart notes
P, 05/2014	KCM X4 and Ready contacts added, KCM switch-on sequence, AKD-M-M1 added, Up/Down renamed to CW/CCW, primary feedback on X7/X9, ISO warning symbols
R, 08/2014	Thermal sensor drawing design and pinout updated for all feedbacks, "NB" hint Tamagawa, DC Bus link information added, DC Bus fusing
T, 12/2014	48A drive information included, CE certificate removed, HR changed acc. to export control
U, 09/2015	EAC certification, 48A drive completed, RoHS/Reach chapters added, FPS added, connector voltage rating corrected, AKD 48A functional safety information, EnDAT 2.2 to X9&X8, KCM wiring corrected, note mains choke for 48A drive
V, 11/2015	Hall-Only Feedback new, hints for "User Guide" replaced by hints for Workbench Onlinehelp, Use as Directed (DC supply / grouping notes), safety standard corrected (EN 62061 for SIL)

About KOLLMORGEN

Kollmorgen is a leading provider of motion systems and components for machine builders. Through world-class knowledge in motion, industry-leading quality and deep expertise in linking and integrating standard and custom products, Kollmorgen delivers breakthrough solutions that are unmatched in performance, reliability and ease-of-use, giving machine builders an irrefutable marketplace advantage.



Join the [Kollmorgen Developer Network](#) for product support. Ask the community questions, search the knowledge base for answers, get downloads, and suggest improvements.

North America KOLLMORGEN

203A West Rock Road
Radford, VA 24141
USA

Web: www.kollmorgen.com

Mail: support@kollmorgen.com

Tel.: +1 - 540 - 633 - 3545

Fax: +1 - 540 - 639 - 4162

Europe KOLLMORGEN Europe GmbH

Pempelfurtstraße 1
40880 Ratingen
Germany

Web: www.kollmorgen.com

Mail: technik@kollmorgen.com

Tel.: +49 - 2102 - 9394 - 0

Fax: +49 - 2102 - 9394 - 3155

China and SEA KOLLMORGEN

Room 202, Building 3, Lane 168,
Lin Hong Road, Changning District
Shanghai

Web: www.kollmorgen.cn

Mail: sales.china@kollmorgen.com

Tel.: +86 - 400 661 2802

Fax: +86 - 21 6071 0665